

### 1.MECHANICAL DIMENSION (UNIT:mm)

### 2. SCHEMATICS:

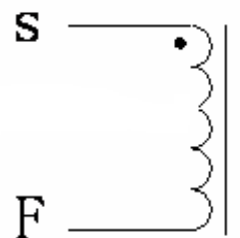
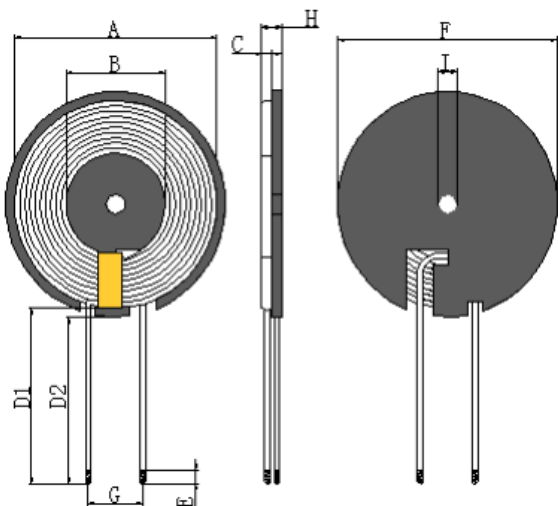

A	B	C	D1	D2	E	F	G	H	I
50±0.5	20.5±0.5	30±0.2	22±0.5	20±0.5	3-4MM	50±0.2		2.3±0.5	5±0.5

### 3.WINDING:

STEP	START-FINISH	WIRE TYPE	TURNS	TAPE	REMARK
N1	S-F	□0.08*105mm 2UEW	10TS (Ref)		

### 4. ELECTRICAL SPECIFICATION:

ITEM	L	DCR	IDC	Q值	HI-POT
TEST	S-F	S-F			
CON	100KHz, 0.25V	AT 25°C			
SPEC	6.5uH±10%	60mΩ Max			

### 5.BILF OF MATERIAL:

NO.	ITEM	MATERIAL SPECIFICATION	MANUFACTURER	SGS NO.
1	CORE	G45L	NANJINGJINNINGCO,LTD	
2	CORE	L33H PRQ3/2.5/0.9	NANJINGJINNINGCO,LTD	
3	WIRE	□0.08mm*105 2UEW	TAIYI CO.,LTD	
4	TUBE	10mm	LIANCHENG CO.,LTD	
5	EPOXY	9999	CUDAK CO.,LTD	

HRSW ELECTRONICS CO.,LTD	PART NO	
	TITLE	G50开槽