



TEST REPORT

FCC PART 15.249

Report Reference No.: CTL1908131051-WF

Compiled by: Happy Guo
(position+printed name+signature) (File administrators)

Happy Guo

Tested by: Nice Nong
(position+printed name+signature) (Test Engineer)

Nice Nong

Approved by: Ivan Xie
(position+printed name+signature) (Manager)

Ivan Xie

Product Name.....: 900MHz Microphone Bodypack Transmitter

Model/Type reference: FA-DC900-TXBP

List Model(s).....: FA-SC900-TXBP, KWM-DC900-TXBP, KWM-SC900-TXBP,
TBD-DC900-TXBP, TBD-SC900-TXBP, OEM-DC900-TXBP,
OEM-SC900-TXBP

Trade Mark:

FCC ID: 2APTAFA-DC900-TXBP

Applicant's name: FLUENT AUDIO INC

Address of applicant: 8362 TAMARACK VILLAGE SUITE# 119-252
WOODBURY, MINNESOTA 55125 USA

Test Firm: **Shenzhen CTL Testing Technology Co., Ltd.**

Address of Test Firm: Floor 1-A, Baisha Technology Park, No.3011, Shahexi Road,
Nanshan District, Shenzhen, China 518055

Test specification: Standard.....: **FCC Part 15.249:**Operation within the bands 920-928 MHz,
2400-2483.5 MHz, 5725-5850 MHz and 24.0 - 24.25 GHz.

TRF Originator: Shenzhen CTL Testing Technology Co., Ltd.

Master TRF: Dated 2011-01

Date of receipt of test item: Aug. 15, 2019

Date of sampling: Aug. 15, 2019

Date of Test Date: Aug. 15, 2019–Sep. 09, 2019

Data of Issue: Sep. 09, 2019

Result: **Pass**

Shenzhen CTL Testing Technology Co., Ltd. All rights reserved.

This publication may be reproduced in whole or in part for non-commercial purposes as long as the Shenzhen CTL Testing Technology Co., Ltd. is acknowledged as copyright owner and source of the material. Shenzhen CTL Testing Technology Co., Ltd. takes no responsibility for and will not assume liability for damages resulting from the reader's interpretation of the reproduced material due to its placement and context.

TEST REPORT

Test Report No. :	CTL1908131051-WF	Sep. 09, 2019 Date of issue
--------------------------	-------------------------	--------------------------------

Equipment under Test : 900MHz Microphone Bodypack Transmitter

Model /Type : FA-DC900-TXBP

Listed Models : FA-SC900-TXBP, KWM-DC900- TXBP,
KWM-SC900-TXBP, TBD-DC900-TXBP,
TBD-SC900-TXBP, OEM-DC900-TXBP,
OEM-SC900-TXBP

Applicant : FLUENT AUDIO INC

Address : 8362 TAMARACK VILLAGE SUITE# 119-252
WOODBURY, MINNESOTA 55125 USA

Manufacturer : ENPING SANREN SOUND EQUIPMENT FACTORY

Address : 3rd&4th Floor, NO.2 Building, Enlong Science and
Technology Park, Enping City, Guangdong, China

Test result	Pass *
--------------------	---------------

* In the configuration tested, the EUT complied with the standards specified page 5.

The test results presented in this report relate only to the object tested.

This report shall not be reproduced, except in full, without the written approval of the issuing testing laboratory.

Table of Contents

Page

1. SUMMARY.....	5
1.1. TEST STANDARDS.....	5
1.2. TEST DESCRIPTION.....	5
1.3. TEST FACILITY.....	6
1.4. STATEMENT OF THE MEASUREMENT UNCERTAINTY.....	6
2. GENERAL INFORMATION.....	8
2.1. ENVIRONMENTAL CONDITIONS.....	8
2.2. GENERAL DESCRIPTION OF EUT.....	8
2.3. DESCRIPTION OF TEST MODES AND TEST FREQUENCY.....	8
2.4. EQUIPMENTS USED DURING THE TEST.....	9
2.5. RELATED SUBMITTAL(S) / GRANT (S).....	9
2.6. MODIFICATIONS.....	9
3. TEST CONDITIONS AND RESULTS.....	10
3.1. CONDUCTED EMISSIONS TEST.....	10
3.2. RADIATED EMISSIONS AND BAND EDGE.....	11
3.3. OCCUPIED BANDWIDTH MEASUREMENT.....	17
3.4. ANTENNA REQUIREMENT.....	19
4. TEST SETUP PHOTOS OF THE EUT.....	20
5. EXTERNAL AND INTERNAL PHOTOS OF THE EUT.....	21

1. SUMMARY

1.1. TEST STANDARDS

The tests were performed according to following standards:

[FCC Rules Part 15.249](#): Operation within the bands 902 - 928 MHz, 2400 - 2483.5 MHz, 5725 - 5875 MHz, and 24.0 - 24.25 GHz.

[ANSI C63.10: 2013](#): American National Standard for Testing Unlicensed Wireless Devices

1.2. Test Description

FCC PART 15.249		
FCC Part 15.249(a)	Field Strength of Fundamental	PASS
FCC Part 15.209	Spurious Emission	PASS
FCC Part 15.209	Band edge	PASS
FCC Part 15.215(c)	20dB bandwidth	PASS
FCC Part 15.207	Conducted Emission	N/A
FCC Part 15.203	Antenna Requirement	PASS

1.3. Test Facility

1.3.1 Address of the test laboratory

Shenzhen CTL Testing Technology Co., Ltd.

Floor 1-A, Baisha Technology Park, No. 3011, Shahexi Road, Nanshan, Shenzhen 518055 China

There is one 3m semi-anechoic chamber and two line conducted labs for final test. The Test Sites meet the requirements in documents ANSI C63.4 and CISPR 32/EN 55032 requirements.

1.3.2 Laboratory accreditation

The test facility is recognized, certified, or accredited by the following organizations:

CNAS-Lab Code: L7497

Shenzhen CTL Testing Technology Co., Ltd. has been assessed and proved to be in compliance with CNAS-CL01 Accreditation Criteria for Testing and Calibration Laboratories (identical to ISO/IEC 17025: 2005 General Requirements) for the Competence of Testing and Calibration Laboratories.

A2LA-Lab Cert. No. 4343.01

Shenzhen CTL Testing Technology Co., Ltd. EMC Laboratory has been accredited by A2LA for technical competence in the field of electrical testing, and proved to be in compliance with ISO/IEC 17025: 2005 General Requirements for the Competence of Testing and Calibration Laboratories and any additional program requirements in the identified field of testing.

IC Registration No.: 9518B

CAB identifier: CN0041

The 3m alternate test site of Shenzhen CTL Testing Technology Co., Ltd. EMC Laboratory has been registered by Innovation, Science and Economic Development Canada to test to Canadian radio equipment requirements with Registration No.: 9518B on Jan. 22, 2019.

FCC-Registration No.: 399832

Designation No.: CN1216

Shenzhen CTL Testing Technology Co., Ltd. EMC Laboratory has been registered and fully described in a report filed with the (FCC) Federal Communications Commission. The acceptance letter from the FCC is maintained in our files. Registration 399832, December 08, 2017.

1.4. Statement of the measurement uncertainty

The data and results referenced in this document are true and accurate. The reader is cautioned that there may be errors within the calibration limits of the equipment and facilities. The measurement uncertainty was calculated for all measurements listed in this test report acc. to CISPR 16 - 4 "Specification for radio disturbance and immunity measuring apparatus and methods – Part 4: Uncertainty in EMC Measurements" and is documented in the Shenzhen CTL Testing Technology Co., Ltd. quality system acc. to DIN EN ISO/IEC 17025. Furthermore, component and process variability of devices similar to that tested may result in additional deviation. The manufacturer has the sole responsibility of continued compliance of the device.

Hereafter the best measurement capability for CTL laboratory is reported:

Test	Measurement Uncertainty	Notes
Transmitter power conducted	±0.57 dB	(1)
Transmitter power Radiated	±2.20 dB	(1)
Conducted spurious emission 9KHz-40 GHz	±2.20 dB	(1)
Occupied Bandwidth	±0.01ppm	(1)
Radiated Emission 30~1000MHz	±4.10dB	(1)
Radiated Emission Above 1GHz	±4.32dB	(1)

Conducted Disturbance0.15~30MHz	$\pm 3.20\text{dB}$	(1)
---------------------------------	---------------------	-----

(1) This uncertainty represents an expanded uncertainty expressed at approximately the 95% confidence level using a coverage factor of $k=2$.

2. GENERAL INFORMATION

2.1. Environmental conditions

During the measurement the environmental conditions were within the listed ranges:

Normal Temperature:	25°C
Relative Humidity:	55 %
Air Pressure:	101 kPa

2.2. General Description of EUT

Product Name:	900MHz Microphone Bodypack Transmitter
Model/Type reference:	FA-DC900-TXBP
Power supply:	DC 3V from battery
900MHz ISM Band wireless	
Operation frequency:	902.3MHz~927.6MHz
Modulation:	FM
Channel number:	85
Channel separation:	0.3MHz
Antenna type:	Monopole antenna
Antenna gain:	0 dBi

Note: For more details, please refer to the user's manual of the EUT.

2.3. Description of Test Modes and Test Frequency

The Applicant provides communication tools software to control the EUT for staying in continuous transmitting (Duty Cycle more than 98%) and receiving mode for testing.

There are 85 channels provided to the EUT and Channel 01/43/85 were selected for test.

Operation Frequency :

Channel	Frequency (MHz)
01	902.3
02	902.6
03	902.9
⋮	⋮
41	914.3
42	914.6
43	915.0
44	915.3
45	915.6
⋮	⋮
83	927.0
84	927.3
85	927.6

Note: The line display in grey were the channel selected for testing

2.4. Equipments Used during the Test

Test Equipment	Manufacturer	Model No.	Serial No.	Calibration Date	Calibration Due Date
LISN	R&S	ENV216	3560.6550.1 2	2019/05/20	2020/05/19
LISN	R&S	ESH2-Z5	860014/010	2019/05/20	2020/05/19
Bilog Antenna	Sunol Sciences Corp.	JB1	A061713	2019/05/20	2020/05/19
EMI Test Receiver	R&S	ESCI	103710	2019/05/20	2020/05/19
Spectrum Analyzer	Agilent	E4407B	MY41440676	2019/05/20	2020/05/19
Spectrum Analyzer	Agilent	N9020	US46220290	2019/05/20	2020/05/19
Power Meter	Anritsu	ML2487B	110553	2019/05/20	2020/05/19
Power Sensor	Anritsu	MA2411B	100345	2019/05/20	2020/05/19
Controller	EM Electronics	Controller EM 1000	N/A	2019/05/20	2020/05/19
Horn Antenna	Sunol Sciences Corp.	DRH-118	A062013	2019/05/20	2020/05/19
Active Loop Antenna	SCHWARZBECK	FMZB1519	1519-037	2019/05/20	2020/05/19
Amplifier	Agilent	8449B	3008A02306	2019/05/20	2020/05/19
Amplifier	Agilent	8447D	2944A10176	2019/05/20	2020/05/19
Temperature/Humidity Meter	Gangxing	CTH-608	02	2019/05/20	2020/05/19
High-Pass Filter	K&L	9SH10-2700/X1 2750-O/O	N/A	2019/05/20	2020/05/19
High-Pass Filter	K&L	41H10-1375/U1 2750-O/O	N/A	2019/05/20	2020/05/19
Coaxial Cables	HUBER+SUHNER	SUCOFLEX 104PEA-10M	10m	2019/05/20	2020/05/19
Coaxial Cables	HUBER+SUHNER	SUCOFLEX 104PEA-3M	3m	2019/05/20	2020/05/19
Coaxial Cables	HUBER+SUHNER	SUCOFLEX 104PEA-3M	3m	2019/05/20	2020/05/19
RF Cable	Megalon	RF-A303	N/A	2019/05/20	2020/05/19

The calibration interval was one year

2.5. Related Submittal(s) / Grant (s)

This submittal(s) (test report) is intended to comply with Section 15.249 of the FCC Part 15, Subpart C Rules.

2.6. Modifications

No modifications were implemented to meet testing criteria.

3. TEST CONDITIONS AND RESULTS

3.1. Conducted Emissions Test

LIMIT

FCC CFR Title 47 Part 15 Subpart C Section 15.207

Frequency range (MHz)	Limit (dBuV)	
	Quasi-peak	Average
0.15-0.5	66 to 56*	56 to 46*
0.5-5	56	46
5-30	60	50

* Decreases with the logarithm of the frequency.

TEST CONFIGURATION

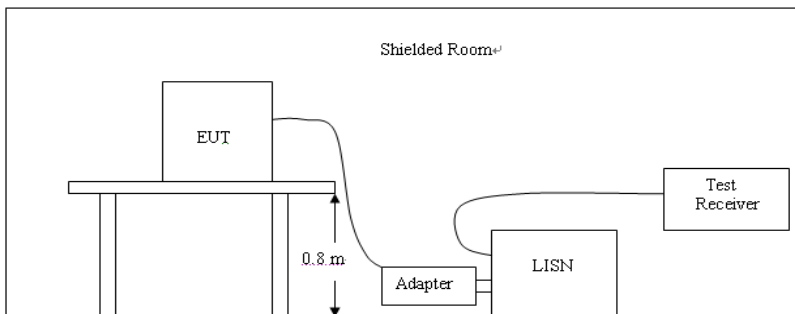

TEST PROCEDURE

1. The equipment was set up as per the test configuration to simulate typical actual usage per the user's manual. The EUT is a tabletop system; a wooden table with a height of 0.8 meters is used and is placed on the ground plane as per ANSI C63.10:2013.
2. Support equipment, if needed, was placed as per ANSI C63.10:2013.
3. All I/O cables were positioned to simulate typical actual usage as per ANSI C63.10:2013.
4. The adapter received AC120V/60Hz power through a Line Impedance Stabilization Network (LISN) which supplied power source and was grounded to the ground plane.
5. All support equipments received AC power from a second LISN, if any.
6. The EUT test program was started. Emissions were measured on each current carrying line of the EUT using a spectrum Analyzer / Receiver connected to the LISN powering the EUT. The LISN has two monitoring points: Line 1 (Hot Side) and Line 2 (Neutral Side). Two scans were taken: one with Line 1 connected to Analyzer / Receiver and Line 2 connected to a 50 ohm load; the second scan had Line 1 connected to a 50 ohm load and Line 2 connected to the Analyzer / Receiver.
7. Analyzer / Receiver scanned from 150 KHz to 30MHz for emissions in each of the test modes.
8. During the above scans, the emissions were maximized by cable manipulation.

TEST RESULTS

Not applicable to this device, which is powered by battery.

3.2. Radiated Emissions and Band Edge

Limit

For intentional device, according to § 15.209(a), the general requirement of field strength of radiated emission out of authorized band shall not exceed the following table at a 3 meters measurement distance.

In addition, radiated emissions which fall in the restricted bands, as defined in §15.205(a), must also comply with the radiated emission limits specified in §15.209(a)

Radiated emission limits

Frequency (MHz)	Distance (Meters)	Radiated (dBµV/m)	Radiated (µV/m)
0.009-0.49	3	$20\log(2400/F(\text{KHz}))+40\log(300/3)$	$2400/F(\text{KHz})$
0.49-1.705	3	$20\log(24000/F(\text{KHz}))+ 40\log(30/3)$	$24000/F(\text{KHz})$
1.705-30	3	$20\log(30)+ 40\log(30/3)$	30
30-88	3	40.0	100
88-216	3	43.5	150
216-960	3	46.0	200
Above 960	3	54.0	500

TEST CONFIGURATION

(A) Radiated Emission Test Set-Up, Frequency Below 30MHz

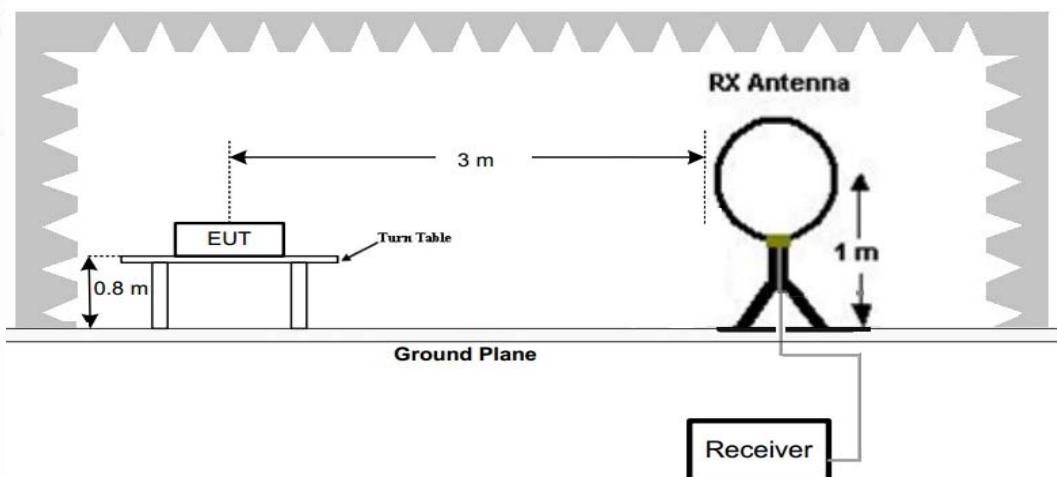

(B) Radiated Emission Test Set-Up, Frequency below 1000MHz

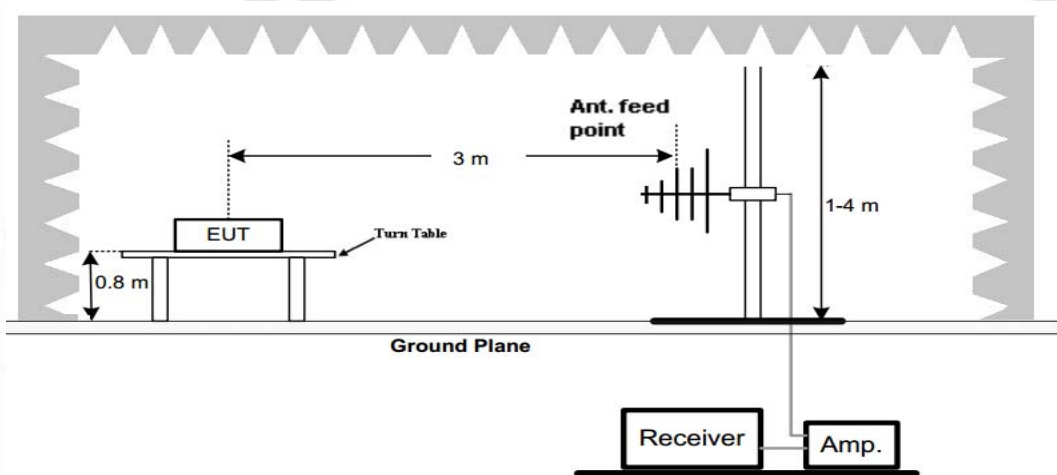

(C) Radiated Emission Test Set-Up, Frequency above 1000MHz

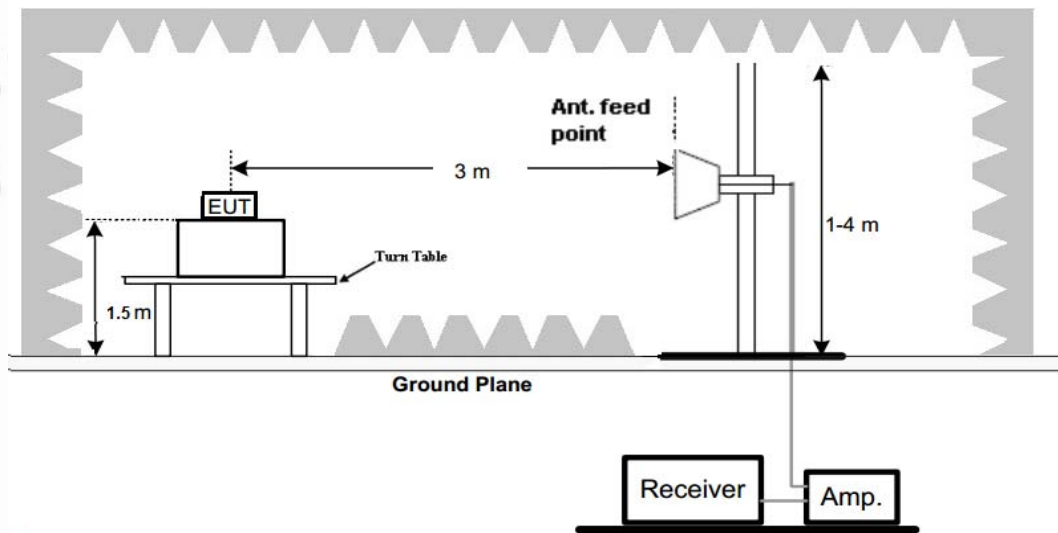

Test Procedure

1. Below 1GHz measurement the EUT is placed on a turntable which is 0.8m above ground plane, and above 1GHz measurement EUT was placed on a low permittivity and low loss tangent turn table which is 1.5m above ground plane.
2. Maximum procedure was performed by raising the receiving antenna from 1m to 4m and rotating the turn table from 0° to 360° to acquire the highest emissions from EUT
3. And also, each emission was to be maximized by changing the polarization of receiving antenna both horizontal and vertical.
4. Repeat above procedures until all frequency measurements have been completed.

TEST RESULTS

Remark:

1. For below 1GHz testing recorded worst at low channel.
2. Radiated emission test from 9 KHz to 10th harmonic of fundamental was verified, and no emission found except system noise floor in 9 KHz to 30MHz and not recorded in this report.

For 30MHz-1GHz

Horizontal

SWEEP TABLE: "test (30M-1G)"

Short Description:		Field Strength			
Start	Stop	Detector	Meas. Time	IF Bandw.	Transducer
30.0 MHz	1.0 GHz	MaxPeak	300.0 ms	120 kHz	VULB9168

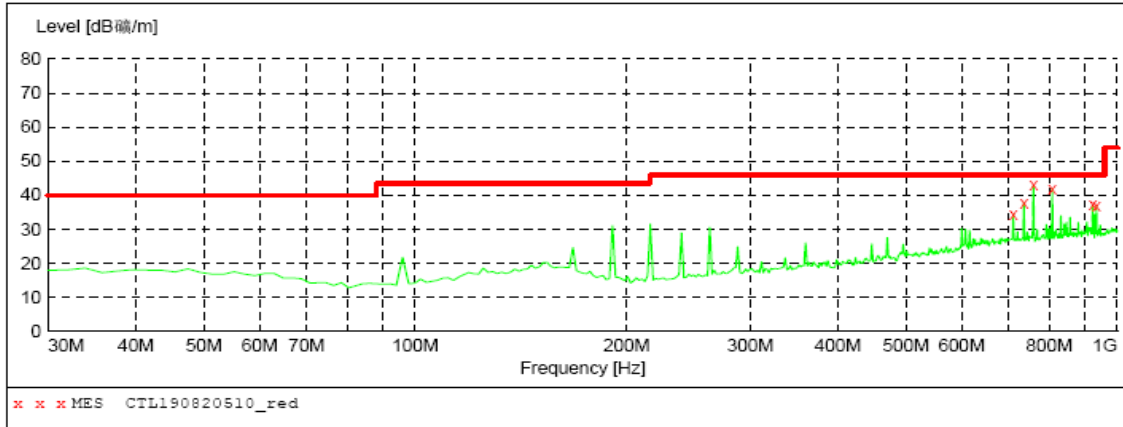

MEASUREMENT RESULT: "CTL190820510_red"

2019-8-21 13:35

Frequency MHz	Level dBμV/m	Transd dB	Limit dBμV/m	Margin dB	Det.	Height cm	Azimuth deg	Polarization
710.940000	34.50	22.0	46.0	11.5	---	0.0	0.00	HORIZONTAL
736.160000	37.80	22.0	46.0	8.2	---	0.0	0.00	HORIZONTAL
759.440000	42.90	22.3	46.0	3.1	---	0.0	0.00	HORIZONTAL
807.940000	41.90	22.8	46.0	4.1	---	0.0	0.00	HORIZONTAL
922.400000	37.20	24.0	46.0	8.8	---	0.0	0.00	HORIZONTAL
934.040000	37.00	24.1	46.0	9.0	---	0.0	0.00	HORIZONTAL

Vertical

SWEEP TABLE: "test (30M-1G)"

Short Description:		Field Strength			
Start	Stop	Detector	Meas. Time	IF Bandw.	Transducer
30.0 MHz	1.0 GHz	MaxPeak	300.0 ms	120 kHz	VULB9168

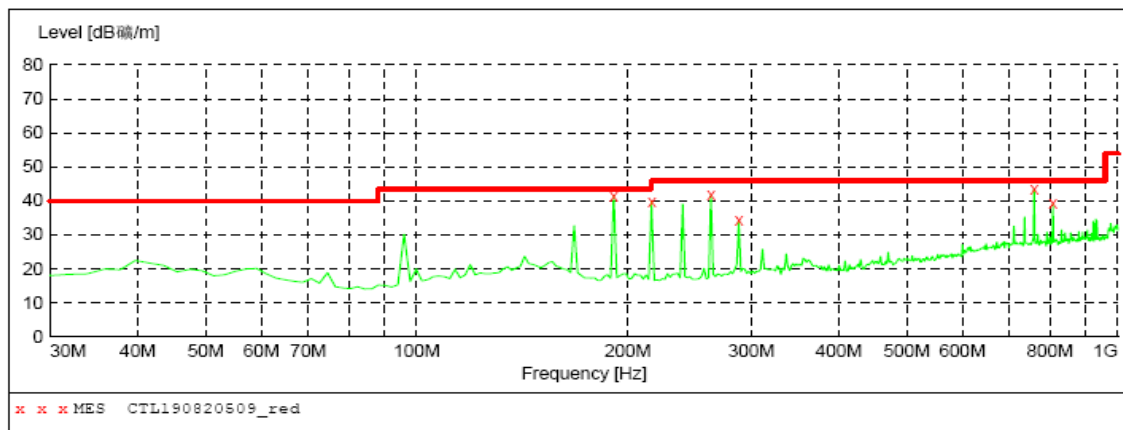

MEASUREMENT RESULT: "CTL190820509_red"

2019-8-21 13:27

Frequency MHz	Level dBμV/m	Transd dB	Limit dBμV/m	Margin dB	Det.	Height cm	Azimuth deg	Polarization
191.020000	41.60	11.5	43.5	1.9	---	0.0	0.00	VERTICAL
216.240000	39.80	11.6	46.0	6.2	---	0.0	0.00	VERTICAL
262.800000	41.70	13.1	46.0	4.3	---	0.0	0.00	VERTICAL
288.020000	34.20	13.1	46.0	11.8	---	0.0	0.00	VERTICAL
759.440000	43.50	22.3	46.0	2.5	---	0.0	0.00	VERTICAL
807.940000	39.20	22.8	46.0	6.8	---	0.0	0.00	VERTICAL

Frequency(MHz):				902.3		Polarity:			Horizontal	
No.	Frequency (MHz)	Emission Level (dBuV/m)		Limit (dBuV/m)	Margin (dB)	Raw Value (dBuV)	Antenna Factor (dB/m)	Cable Factor (dB)	Pre-amplifier (dB)	Correction Factor (dB/m)
1	216.24	40.33	PK	46.00	5.67	56.49	11.42	1.18	28.76	-16.16
2	900.00	41.30	PK	46.00	4.70	45.19	22.10	2.16	28.15	-3.89
3	902.30	96.65	PK	114.00	17.35	98.73	23.85	2.20	28.13	-2.08
3	902.30	90.82	AV	94.00	3.18	92.90	23.85	2.20	28.13	-2.08
4	1804.60	56.16	PK	74.00	17.84	60.21	27.17	4.01	35.23	-4.05
4	1804.60	50.84	AV	54.00	3.16	54.89	27.17	4.01	35.23	-4.05
5	2706.90	54.21	PK	74.00	19.79	54.55	29.33	4.94	34.61	-0.34
5	2706.90	47.18	AV	54.00	6.82	47.52	29.33	4.94	34.61	-0.34
6	3609.20	50.50	PK	74.00	23.50	47.54	32.08	5.95	35.07	2.96
6	3609.20	--	AV	54.00	--	--	--	--	--	--
7	4511.50	45.69	PK	74.00	28.31	40.59	32.88	6.73	34.51	5.10
7	4511.50	--	AV	54.00	--	--	--	--	--	--

Frequency(MHz):				902.3		Polarity:			Vertical	
No.	Frequency (MHz)	Emission Level (dBuV/m)		Limit (dBuV/m)	Margin (dB)	Raw Value (dBuV)	Antenna Factor (dB/m)	Cable Factor (dB)	Pre-amplifier (dB)	Correction Factor (dB/m)
1	216.24	41.22	PK	46.00	4.78	57.38	11.42	1.18	28.76	-16.16
2	900.00	40.68	PK	46.00	5.32	44.57	22.10	2.16	28.15	-3.89
3	902.30	95.59	PK	114.00	18.41	97.67	23.85	2.20	28.13	-2.08
3	902.30	89.36	AV	94.00	4.64	91.44	23.85	2.20	28.13	-2.08
4	1804.60	56.45	PK	74.00	17.55	60.50	27.17	4.01	35.23	-4.05
4	1804.60	49.98	AV	54.00	4.02	54.03	27.17	4.01	35.23	-4.05
5	2706.90	54.17	PK	74.00	19.83	54.51	29.33	4.94	34.61	-0.34
5	2706.90	48.47	AV	54.00	5.53	48.81	29.33	4.94	34.61	-0.34
6	3609.20	49.62	PK	74.00	24.38	46.66	32.08	5.95	35.07	2.96
6	3609.20	--	AV	54.00	--	--	--	--	--	--
7	4511.50	46.76	PK	74.00	27.24	41.66	32.88	6.73	34.51	5.10
7	4511.50	--	AV	54.00	--	--	--	--	--	--

REMARKS:

1. Emission level (dBuV/m) =Raw Value (dBuV)+Correction Factor (dB/m)
2. Correction Factor (dB/m) = Antenna Factor (dB/m)+Cable Factor (dB)-Pre-amplifier Factor
3. Margin value = Limit value- Emission level.
4. -- Mean the PK detector measured value is below QP/AV limit.
5. The other emission levels were very low against the limit.

RBW100KHz VBW300KHz for test at below 1GHz; RBW1MHz VBW3MHz Peak detector is for PK value, RBW 1MHz VBW10Hz Peak detector is for AV value for test at above 1GHz.

Frequency(MHz):				915		Polarity:			Horizontal	
No.	Frequency (MHz)	Emission Level (dBuV/m)		Limit (dBuV/m)	Margin (dB)	Raw Value (dBuV)	Antenna Factor (dB/m)	Cable Factor (dB)	Pre-amplifier (dB)	Correction Factor (dB/m)
1	262.00	41.67	PK	46.00	4.33	56.25	12.90	1.25	28.73	-14.58
2	900.00	30.78	PK	46.00	15.22	34.67	22.10	2.16	28.15	-3.89
3	915.00	96.38	PK	114.00	17.62	99.93	22.48	2.10	28.13	-3.55
3	915.00	90.95	AV	94.00	3.05	94.50	22.48	2.10	28.13	-3.55
4	1830.00	56.40	PK	74.00	17.60	60.29	27.31	4.04	35.23	-3.89
4	1830.00	89.26	AV	54.00	-35.26	93.15	27.31	4.04	35.23	-3.89
5	2745.00	53.14	PK	74.00	20.86	53.27	29.47	4.98	34.58	-0.13
5	2745.00	47.08	AV	54.00	6.92	47.21	29.47	4.98	34.58	-0.13
6	3660.00	50.06	PK	74.00	23.94	46.69	32.39	6.01	35.03	3.37
6	3660.00	--	AV	54.00	--	--	--	--	--	--
7	4575.00	46.31	PK	74.00	27.69	41.04	32.97	6.77	34.47	5.27
7	4575.00	--	AV	54.00	--	--	--	--	--	--

Frequency(MHz):				915		Polarity:			Vertical	
No.	Frequency (MHz)	Emission Level (dBuV/m)		Limit (dBuV/m)	Margin (dB)	Raw Value (dBuV)	Antenna Factor (dB/m)	Cable Factor (dB)	Pre-amplifier (dB)	Correction Factor (dB/m)
1	262.00	38.27	PK	46.00	7.73	52.85	12.90	1.25	28.73	-14.58
2	900.00	31.56	PK	46.00	14.44	35.45	22.10	2.16	28.15	-3.89
3	915.00	95.75	PK	114.00	18.25	99.30	22.48	2.10	28.13	-3.55
3	915.00	89.12	AV	94.00	4.88	92.67	22.48	2.10	28.13	-3.55
4	1830.00	55.09	PK	74.00	18.91	58.98	27.31	4.04	35.23	-3.89
4	1830.00	49.73	AV	54.00	4.27	53.62	27.31	4.04	35.23	-3.89
5	2745.00	53.65	PK	74.00	20.35	53.78	29.47	4.98	34.58	-0.13
5	2745.00	47.83	AV	54.00	6.17	47.96	29.47	4.98	34.58	-0.13
6	3660.00	48.40	PK	74.00	25.60	45.03	32.39	6.01	35.03	3.37
6	3660.00	--	AV	54.00	--	--	--	--	--	--
7	4575.00	45.23	PK	74.00	28.77	39.96	32.97	6.77	34.47	5.27
7	4575.00	--	AV	54.00	--	--	--	--	--	--

REMARKS:

1. Emission level (dBuV/m) =Raw Value (dBuV)+Correction Factor (dB/m)
2. Correction Factor (dB/m) = Antenna Factor (dB/m)+Cable Factor (dB)-Pre-amplifier Factor
3. Margin value = Limit value- Emission level.
4. -- Mean the PK detector measured value is below QP/AV limit.
5. The other emission levels were very low against the limit.
6. RBW100KHz VBW300KHz for test at below 1GHz; RBW1MHz VBW3MHz Peak detector is for PK value, RBW 1MHz VBW10Hz Peak detector is for AV value for test at above 1GHz.

Frequency(MHz):				927.6		Polarity:			Horizontal	
No.	Frequency (MHz)	Emission Level (dBuV/m)		Limit (dBuV/m)	Margin (dB)	Raw Value (dBuV)	Antenna Factor (dB/m)	Cable Factor (dB)	Pre-amplifier (dB)	Correction Factor (dB/m)
1	759.44	39.25	PK	46.00	6.75	44.59	20.99	1.95	28.28	-5.34
2	960.00	31.72	PK	46.00	14.28	34.80	22.92	2.10	28.10	-3.08
3	927.60	96.39	PK	114.00	17.61	99.77	22.64	2.10	28.12	-3.38
3	927.60	91.28	AV	94.00	2.72	94.66	22.64	2.10	28.12	-3.38
4	1855.00	56.94	PK	74.00	17.06	60.68	27.44	4.06	35.24	-3.74
4	1855.00	51.57	AV	54.00	2.43	55.31	27.44	4.06	35.24	-3.74
5	2782.50	54.13	PK	74.00	19.87	54.04	29.61	5.02	34.54	0.09
5	2782.50	48.14	AV	54.00	5.86	48.05	29.61	5.02	34.54	0.09
6	3710.00	50.01	PK	74.00	23.99	46.23	32.70	6.07	35.00	3.78
6	3710.00	--	AV	54.00	--	--	--	--	--	--
7	4637.50	47.82	PK	74.00	26.18	42.35	33.10	6.81	34.44	5.47
7	4637.50	--	AV	54.00	--	--	--	--	--	--

Frequency(MHz):				927.6		Polarity:			Vertical	
No.	Frequency (MHz)	Emission Level (dBuV/m)		Limit (dBuV/m)	Margin (dB)	Raw Value (dBuV)	Antenna Factor (dB/m)	Cable Factor (dB)	Pre-amplifier (dB)	Correction Factor (dB/m)
1	759.44	40.24	PK	46.00	5.76	45.58	20.99	1.95	28.28	-5.34
2	960.00	35.76	PK	46.00	10.24	38.84	22.92	2.10	28.10	-3.08
3	927.60	95.65	PK	114.00	18.35	99.03	22.64	2.10	28.12	-3.38
3	927.60	88.64	AV	94.00	5.36	92.02	22.64	2.10	28.12	-3.38
4	1855.00	55.24	PK	74.00	18.76	58.98	27.44	4.06	35.24	-3.74
4	1855.00	49.33	AV	54.00	4.67	53.07	27.44	4.06	35.24	-3.74
5	2782.50	53.73	PK	74.00	20.27	53.64	29.61	5.02	34.54	0.09
5	2782.50	47.87	AV	54.00	6.13	47.78	29.61	5.02	34.54	0.09
6	3710.00	49.79	PK	74.00	24.21	46.01	32.70	6.07	35.00	3.78
6	3710.00	--	AV	54.00	--	--	--	--	--	--
7	4637.50	47.12	PK	74.00	26.88	41.65	33.10	6.81	34.44	5.47
7	4637.50	--	AV	54.00	--	--	--	--	--	--

REMARKS:

1. Emission level (dBuV/m) =Raw Value (dBuV)+Correction Factor (dB/m)
2. Correction Factor (dB/m) = Antenna Factor (dB/m)+Cable Factor (dB)-Pre-amplifier Factor
3. Margin value = Limit value- Emission level.
4. -- Mean the PK detector measured value is below QP/AV limit.
5. The other emission levels were very low against the limit.

RBW100KHz VBW300KHz for test at below 1GHz; RBW1MHz VBW3MHz Peak detector is for PK value, RBW 1MHz VBW10Hz Peak detector is for AV value for test at above 1GHz.

3.3. Occupied Bandwidth Measurement

Limit

N/A

Test Procedure

The transmitter output was connected to the spectrum analyzer through an attenuator. The bandwidth of the fundamental frequency was measured by spectrum analyzer with 3 KHz RBW and 10 KHz VBW. The 20dB bandwidth is defined as the total spectrum the power of which is higher than peak power minus 20dB.

Test Configuration

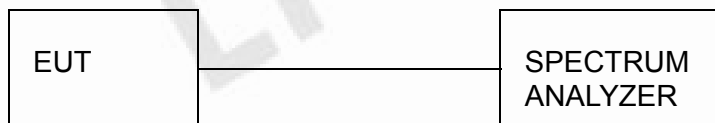

Test Results

Type	Channel	99% OBW (KHz)	20dB bandwidth (KHz)	Result
FM	01	64.975	66.18	Pass
	43	63.960	65.82	
	85	64.416	65.98	

Test plot as follows:

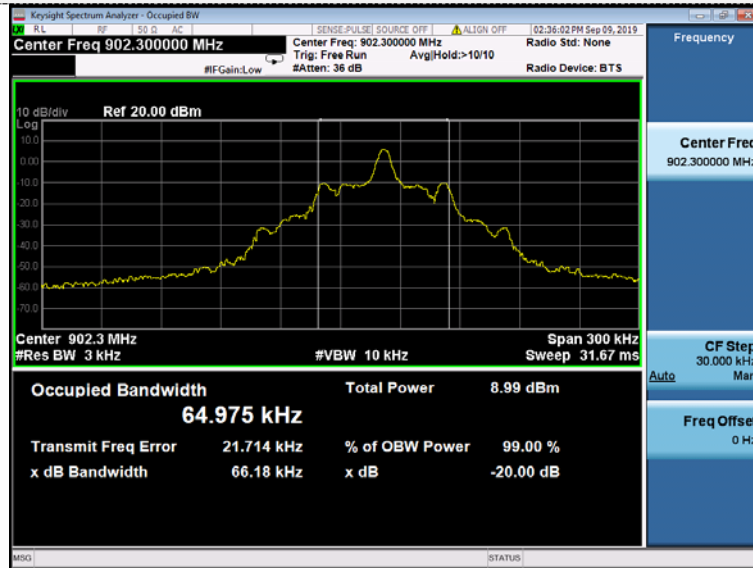

CH01

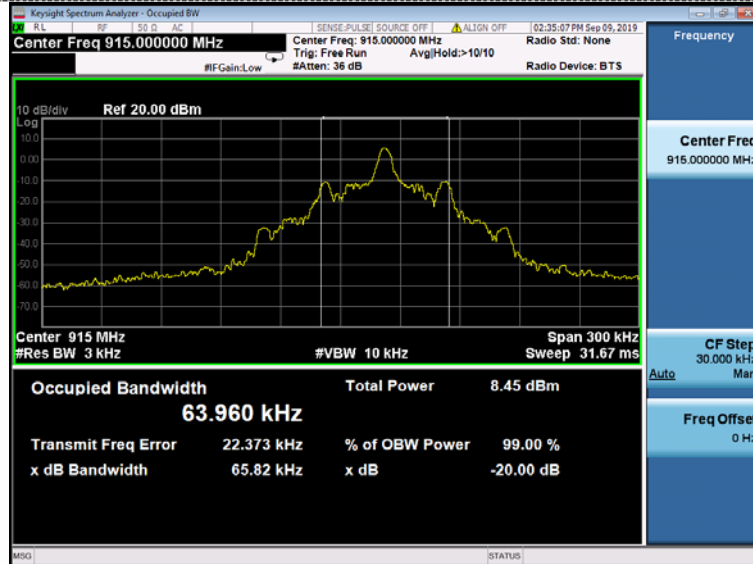

CH43

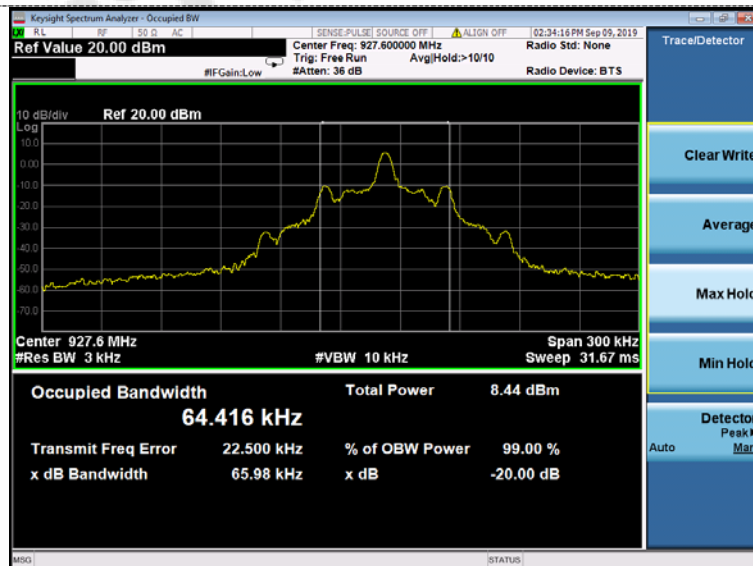

CH85

3.4. Antenna Requirement

Standard Applicable

For intentional device, according to FCC 47 CFR Section 15.203, an intentional radiator shall be designed to ensure that no antenna other than that furnished by the responsible party shall be used with the device.

Refer to statement below for compliance.

The manufacturer may design the unit so that the user can replace a broken antenna, but the use of a standard antenna jack or electrical connector is prohibited. Further, this requirement does not apply to intentional radiators that must be professionally installed.

Test Result:

The directional gains of antenna used for transmitting is 0 dBi, and the antenna connector is designed with permanent attachment and no consideration of replacement. Please see EUT photo for details.

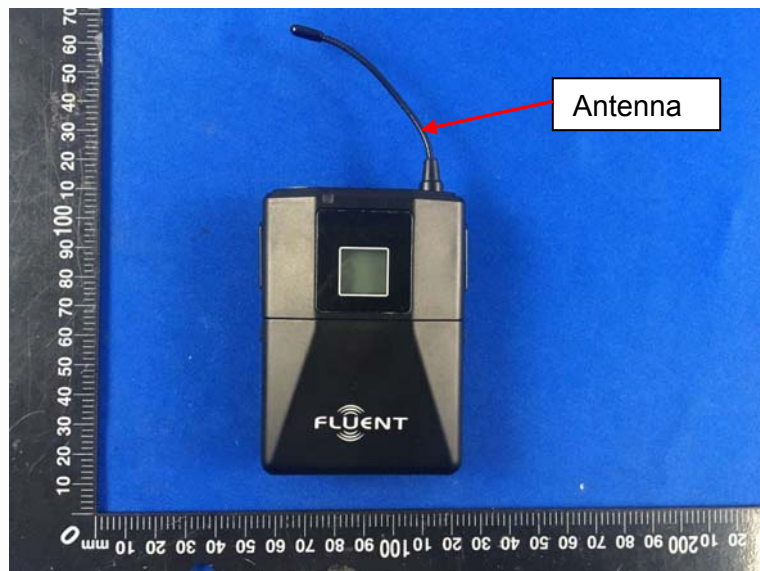

4. Test Setup Photos of the EUT

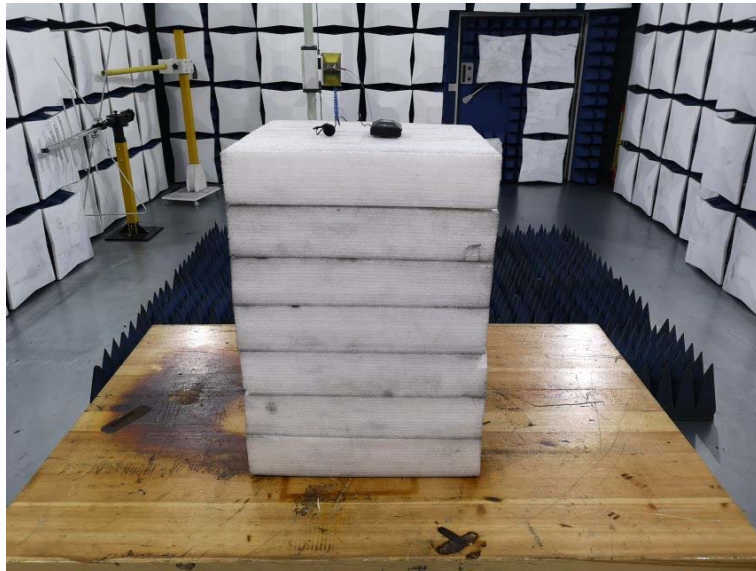
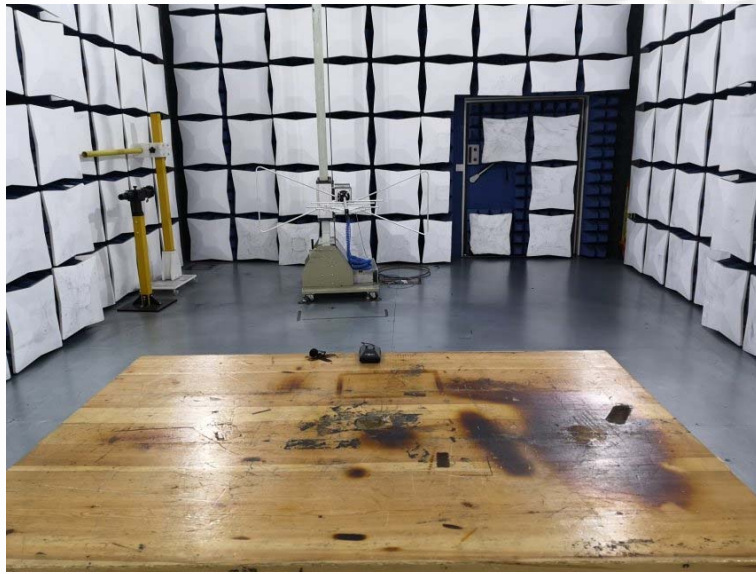

5. External and Internal Photos of the EUT

External Photos of EUT

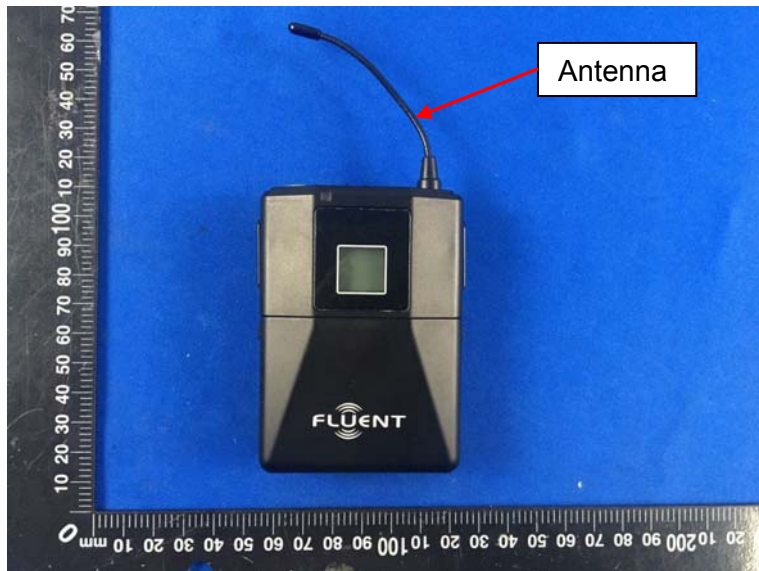





Internal Photos of EUT

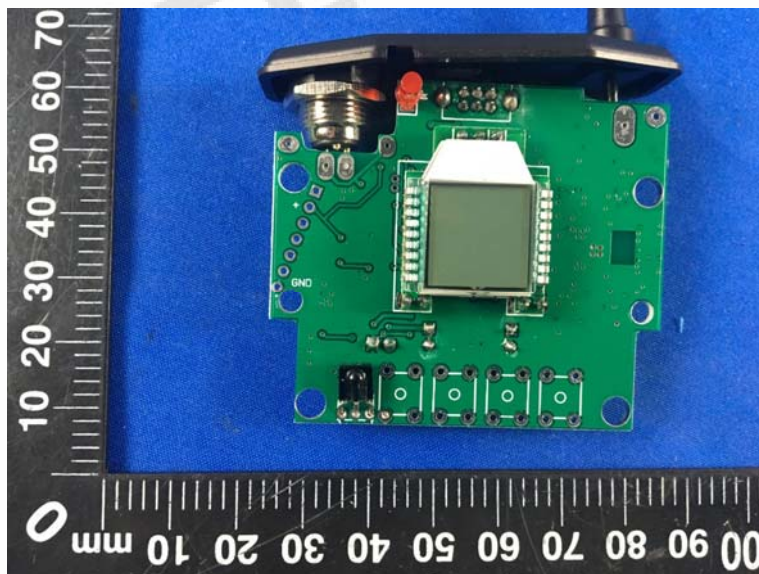
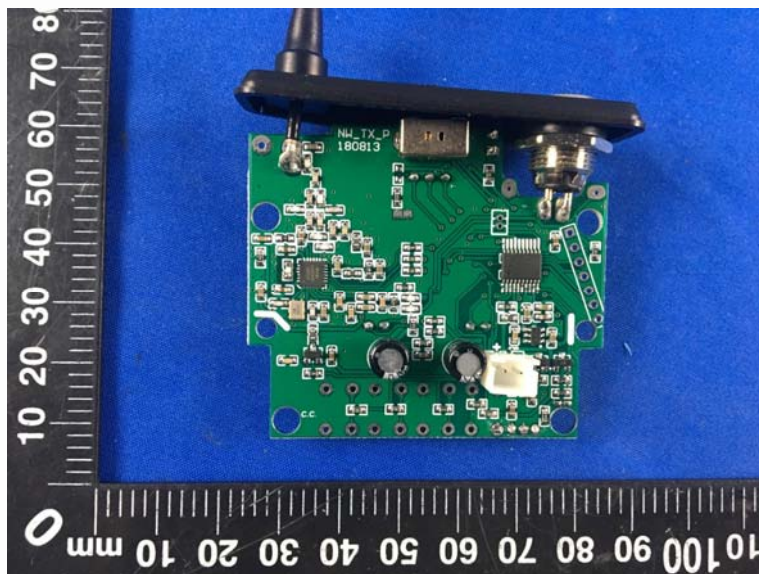

***** End of Report *****