

# High Power Wireless Router

Model: YN-AR41AP

## Product Description

The YN-AR41AP is a high power wireless router, it is support 802.11N and transmission rate up to 300Mbps. It can be suitable for complex environments such as automation equipment, intelligent monitoring, environmental monitoring, wind power generation and so on.

## Product Feature

1. Comply with IEEE802.11N, IEEE802.11G/B,
2. Industrial grade design, more stable performance, wireless transmission rate up to 300M
3. WAN port support POE power supply (24-48V)
4. Support Open-Wrt third-party firmware and secondary development, so the system can be customized flexibly
5. Support multiple wireless network types: AP mode and route relay

## Product Specification

|                       |   |             |             |
|-----------------------|---|-------------|-------------|
| Protocol              | IEEE802.11N/G/B   |             |             |
| Chipset               | AR9341/600MHz   |             |             |
| Memory                | 64MB  |             |             |
| FLASH                 | 8MB, can be extend to 16MB  |             |             |
| Wireless Rate         | 2T2R:300Mbps  |             |             |
| Working Frequency     | 2.4Ghz  |             |             |
| Interfaces            | Support 1 of 10/100M adaptive WAN PHY interface, support automatic flip (Auto MDI/MDIX)<br>Support 4 of 10/100M adaptive LAN PHY interfaces, support automatic flip (Auto MDI/MDIX) |             |             |
| Max.Power Consumption | <8W   |             |             |
| Dimension             | 132X88X18MM   |             |             |
| Working Environment   | Operating Temperature: -40 ~ 55 °C<br>Storage Temperature: -40 ~ 00 °C<br>Working Humidity: 10%-90% RH no condense;<br>Storage humidity: 5%-90% RH no condense                      |             |             |
| Sensitivity           | G mode  | 11N HT20    | 11N HT40    |
|                       | OFDM 6Mbps≤-89  | MCS0/8≤-83  | MCS0/8≤-80  |
|                       | OFDM 9Mbps≤-88  | MCS1/9≤-80  | MCS1/9≤-77  |
|                       | OFDM 12Mbps≤-85   | MCS2/10≤-78 | MCS2/10≤-75 |
|                       | OFDM 18Mbps≤-83   | MCS3/11≤-75 | MCS3/11≤-72 |
|                       | OFDM 24Mbps≤-80   | MCS4/12≤-71 | MCS4/12≤-68 |

|                   |  |             |             |
|-------------------|--|-------------|-------------|
|                   | OFDM 36Mbps≤-75  | MCS5/13≤-67 | MCS5/13≤-64 |
|                   | OFDM 48Mbps≤-71  | MCS6/14≤-66 | MCS6/14≤-63 |
|                   | OFDM 54Mbps≤-70  | MCS7/15≤-65 | MCS7/15≤-62 |
| Wireless Security | Wireless safety function switch;<br>64/128/152 bit WEP encryption;<br>WPA-PSK/WPA2-PSK,WPA/WPA2security mechanism;<br>WPS fast security settings   |             |             |
| Software Feature  | Support AP, router, relay, 4G function and so on.<br><br>Support VPN security tunnel function,<br><br>Support dynamic routing and static routing<br><br>Convenient WEB configuration<br><br>Wireless settings and encryption<br><br>Support telnet management, easy to use console shell interactive environment<br><br>Support multiple dialing methods: automatic allocation, specify IP, specify local peer IP, ppoe<br><br>Support local software upgrade; support configuration export import, and web online update firmware<br><br>Support operating system Windows XP/7/8/9/10/Linux |             |             |

# Product Design

Top

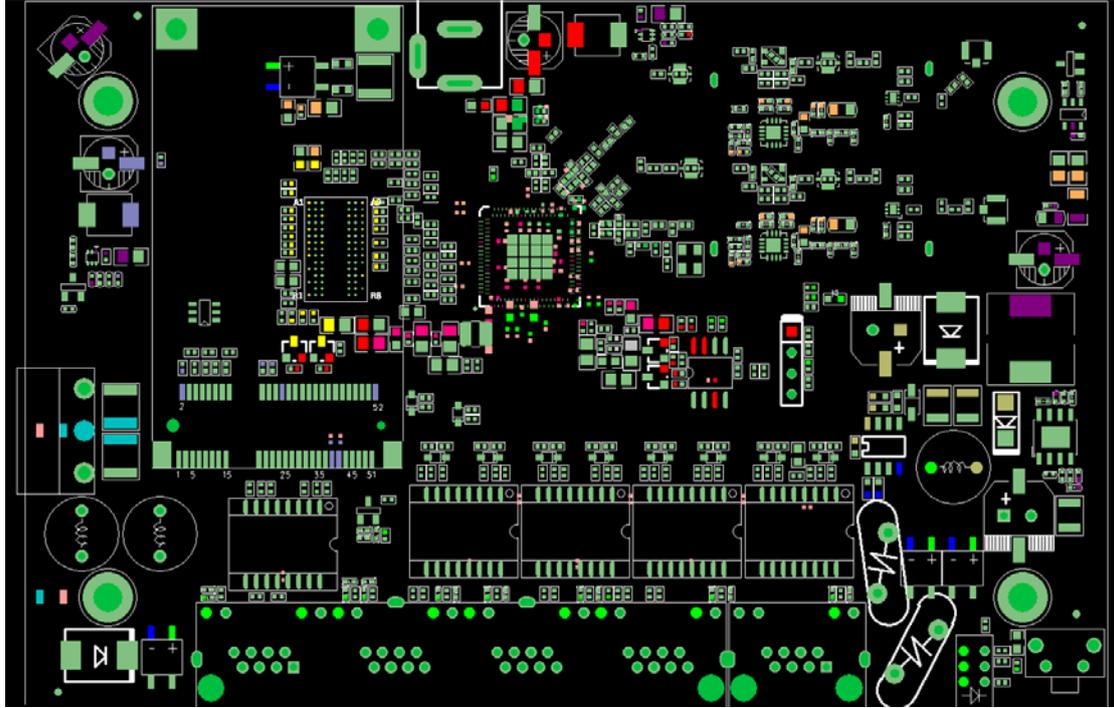

Bottom

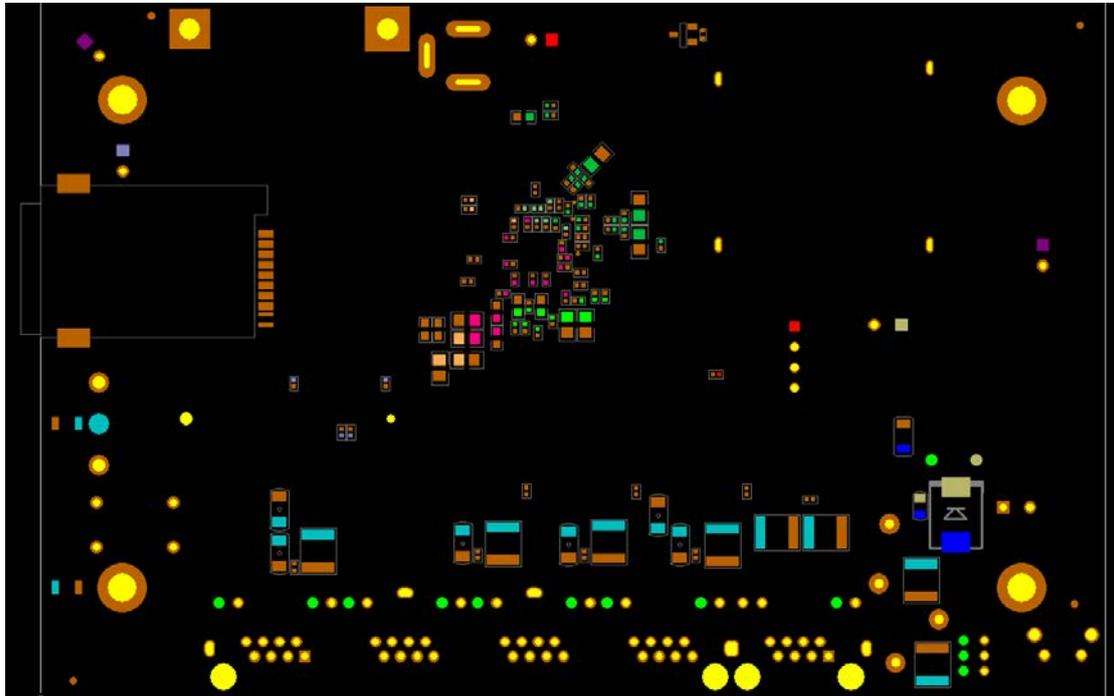

## Product Structure

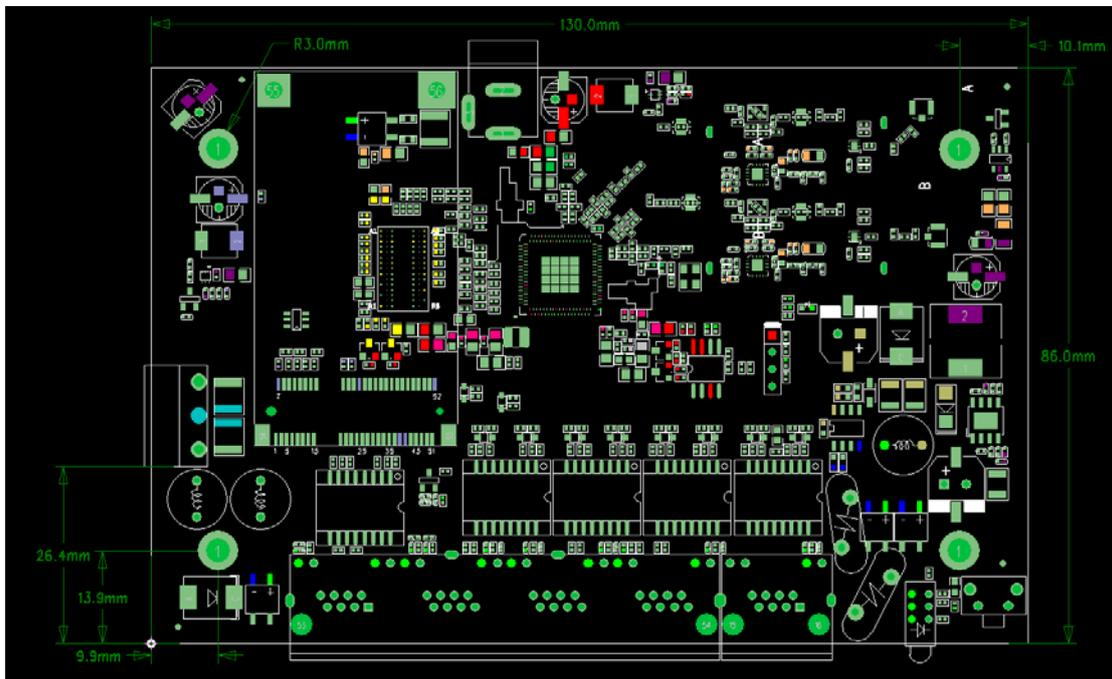

## Product Interface Definition

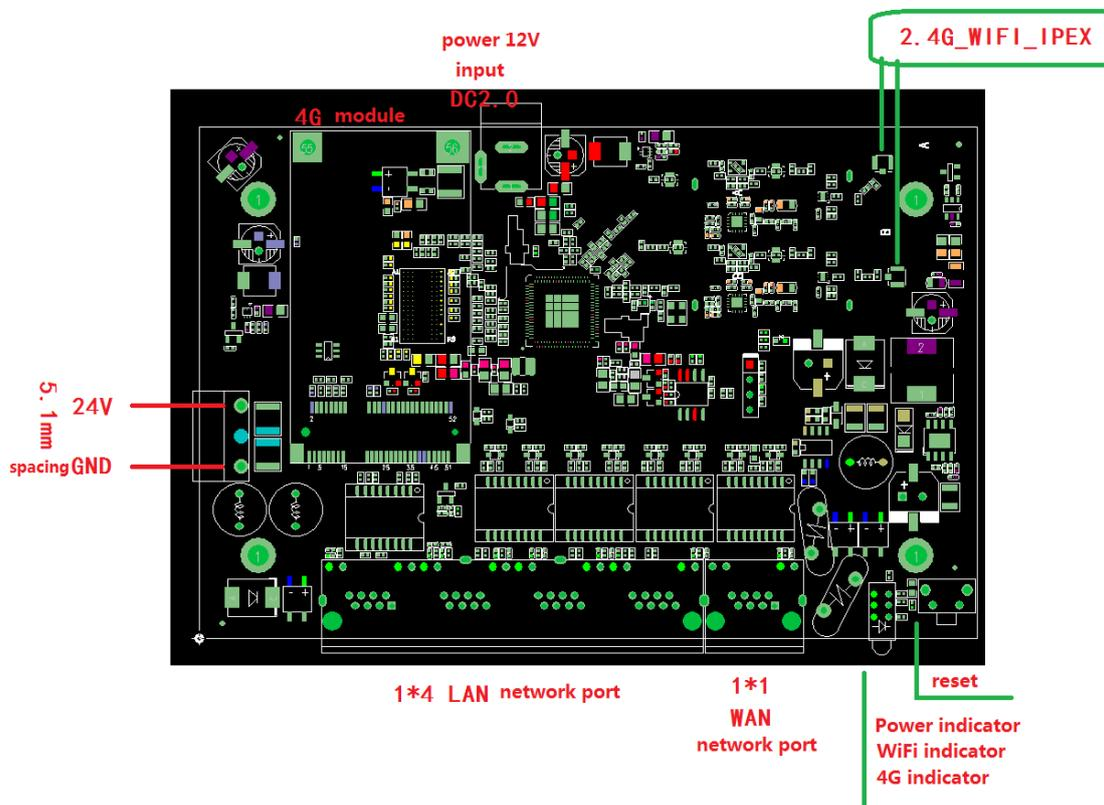

## Antenna

The EUT antenna is External antenna, The antenna can be removed, Unconventional interface, Antenna A gain: 5dBi, Antenna B gain: 5dBi, Dual antenna design only supports MIMO mode in 802.11n(20) and 802.11n(40)

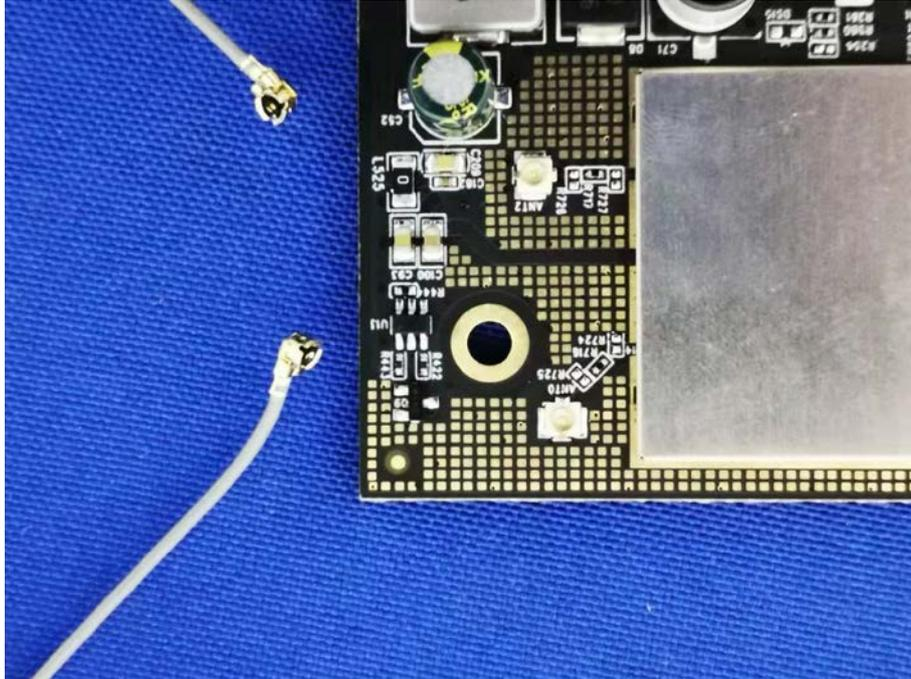

## Product Applications

Intelligent Transportation: 1. HD electronic bayonet application 2. HD electronic police application 3. Road wireless video

Surveillance Vehicle monitoring: 1. Bus wireless video surveillance 2. Taxi video surveillance 3. Bus video surveillance

Security monitoring: 1. Security wireless mobile detection system 2. Security wireless video surveillance

Industrial monitoring: 1. Site wireless video surveillance 2. Industrial big data transmission 3 Remote crane monitoring and management 4. Elevator remote monitoring

Financial industry: 1. Wireless ATM self-service terminal 2. Coal mine tax monitoring system 3. Wireless POS application

Power industry: 1. Substation 3G video surveillance 2. Transformer remote monitoring management 3. Power line video surveillance

Environmental protection industry: 1.3G noise monitoring system 2. Wireless monitoring system for pollution sources 3. Wireless environmental monitoring system

Water conservancy industry: 1. Reservoir remote monitoring system 2. Water environment comprehensive monitoring system

Other industries: 1. Municipal engineering 2. Petroleum monitoring 3. Agricultural applications 4. Wireless WIFI applications



## FCC WARNING

FCC Caution: Any changes or modifications not expressly approved by the party responsible for compliance could void the user's authority to operate this equipment.

This device complies with Part 15 of the FCC Rules.

Operation is subject to the following two conditions: (1) This device may not cause harmful interference, and (2) this device must accept any interference received, including interference that may cause undesired operation.

This device and its antenna(s) must not be co-located or operating in conjunction with any other antenna or transmitter.

15.105 Information to the user.

(b) For a Class B digital device or peripheral, the instructions furnished the user shall include the following or similar statement, placed in a prominent location in the text of the manual:

Note: This equipment has been tested and found to comply with the limits for a Class B digital device, pursuant to part 15 of the FCC Rules.

These limits are designed to provide reasonable protection against harmful interference in a residential installation. This equipment generates, uses and can radiate radio frequency energy and, if not installed and used in accordance with the instructions, may cause harmful interference to radio communications. However, there is no guarantee that interference will not occur in a particular installation. If this equipment does cause harmful interference to radio or television reception, which can be determined by turning the equipment off and on, the user is encouraged to try to correct the interference by one or more of the following measures:

—Reorient or relocate the receiving antenna.

—Increase the separation between the equipment and receiver.

—Connect the equipment into an outlet on a circuit different from that to which the receiver is connected.

—Consult the dealer or an experienced radio/TV technician for help.

This equipment complies with FCC radiation exposure limits set forth for an uncontrolled

environment. This equipment should be installed and operated with minimum distance 20

cm between the radiator and your body.

Radiation Exposure Statement:

This equipment complies with FCC radiation exposure limits set forth for an uncontrolled environment.

This transmitter must not be co-located or operating in conjunction with any other antenna or transmitter.

The availability of some specific channels and/or operational frequency bands are country dependent and are firmware programmed at the factory to match the intended destination.

The firmware setting is not accessible by the end user.

The final end product must be labelled in a visible area with the following:

“Contains Transmitter Module 2APT7AR41AP”

## Requirement per KDB996369 D03

### 2.2 List of applicable FCC rules

List the FCC rules that are applicable to the modular transmitter. These are the rules that specifically establish the bands of operation, the power, spurious emissions, and operating fundamental frequencies. DO NOT list compliance to unintentional-radiator rules (Part 15 Subpart B) since that is not a condition of a module grant that is extended to a host manufacturer. See also Section 2.10 below concerning the need to notify host manufacturers that further testing is required.<sup>3</sup>

**Explanation:** This module meets the requirements of FCC part 15C(15.247).it specifically establish the 6dB Bandwidth, Peak Output Power, Radiated Spurious Emission, Power Spectral Density, Restricted Band of Operation and Band Edge (Out of Band Emissions)

### 2.3 Summarize the specific operational use conditions

Describe use conditions that are applicable to the modular transmitter, including for example any limits on antennas, etc. For example, if point-to-point antennas are used that require reduction in power or compensation for cable loss, then this information must be in the instructions. If the use condition limitations extend to professional users, then instructions must state that this information also extends to the host manufacturer's instruction manual. In addition, certain information may also be needed, such as peak gain per frequency band and minimum gain, specifically for master devices in 5 GHz DFS bands.

**Explanation:** The module has two external antenna, The antenna cannot be removed, Unconventional interface

### 2.4 Limited module procedures

If a modular transmitter is approved as a "limited module," then the module manufacturer is

responsible for approving the host environment that the limited module is used with. The manufacturer of a limited module must describe, both in the filing and in the installation instructions, the alternative means that the limited module manufacturer uses to verify that the host meets the necessary requirements to satisfy the module limiting conditions.

A limited module manufacturer has the flexibility to define its alternative method to address the conditions that limit the initial approval, such as: shielding, minimum signaling amplitude, buffered modulation/data inputs, or power supply regulation. The alternative method could include that the limited module manufacturer reviews detailed test data or host designs prior to giving the host manufacturer approval.

This limited module procedure is also applicable for RF exposure evaluation when it is necessary to demonstrate compliance in a specific host. The module manufacturer must state how control of the product into which the modular transmitter will be installed will be maintained such that full compliance of the product is always ensured. For additional hosts other than the specific host originally granted with a limited



module, a Class II permissive change is required on the module grant to register the additional host as a specific host also approved with the module.

**Explanation:** The module is a single module.

## 2.5 Trace antenna designs

For a modular transmitter with trace antenna designs, see the guidance in Question 11 of KDB Publication 996369 D02 FAQ – Modules for Micro-Strip Antennas and traces. The integration information shall include for the TCB review the integration instructions for the following aspects: layout of trace design, parts list (BOM), antenna, connectors, and isolation requirements.

- a) Information that includes permitted variances (e.g., trace boundary limits, thickness, length, width, shape(s), dielectric constant, and impedance as applicable for each type of antenna);
- b) Each design shall be considered a different type (e.g., antenna length in multiple(s) of frequency, the wavelength, and antenna shape (traces in phase) can affect antenna gain and must be considered);
- c) The parameters shall be provided in a manner permitting host manufacturers to design the printed circuit (PC) board layout;
- d) Appropriate parts by manufacturer and specifications;
- e) Test procedures for design verification; and
- f) Production test procedures for ensuring compliance.

The module grantee shall provide a notice that any deviation(s) from the defined parameters of the antenna trace, as described by the instructions, require that the host product manufacturer must notify the module grantee that they wish to change the antenna trace design. In this case, a Class II permissive change application is required to be filed by the grantee, or the host manufacturer can take responsibility through the change in FCC ID (new application) procedure followed by a Class II permissive change application.

**Explanation:** Yes, The module with trace antenna designs, and This manual has been shown the layout of trace design,, antenna, connectors, and isolation requirements.

## 2.6 RF exposure considerations

It is essential for module grantees to clearly and explicitly state the RF exposure conditions that permit a host product manufacturer to use the module. Two types of instructions are required for RF exposure information: (1) to the host product manufacturer, to define the application conditions (mobile, portable – xx cm from a person's body); and (2) additional text needed for the host product manufacturer to provide to end users in their end-product manuals. If RF exposure statements and use conditions are not provided, then the host product manufacturer is required to take responsibility of the module through a change in FCC ID (new application).

**Explanation:** This module complies with FCC RF radiation exposure limits set forth for an uncontrolled environment, This equipment should be installed and operated with a minimum distance of 20 centimeters between the radiator and your body." This module is designed to comply with the FCC statement, FCC ID is: 2APT7AR41AP.

## 2.7 Antennas

A list of antennas included in the application for certification must be provided in the instructions. For modular transmitters approved as limited modules, all applicable professional installer instructions must be included as part of the information to the host product manufacturer. The antenna list shall also identify the antenna types (monopole, PIFA, dipole, etc. (note that for example an "omni-directional antenna" is not considered to be a specific "antenna type"))).

For situations where the host product manufacturer is responsible for an external connector, for example with an RF pin and antenna trace design, the integration instructions shall inform the installer that unique antenna connector must be used on the Part 15 authorized transmitters used in the host product. The module manufacturers shall provide a list of acceptable unique connectors.

**Explanation:** The EUT has two External Antenna, The antenna cannot be removed, Unconventional interface

## 2.8 Label and compliance information

Grantees are responsible for the continued compliance of their modules to the FCC rules. This

includes advising host product manufacturers that they need to provide a physical or e-label stating "Contains FCC ID" with their finished product. See [Guidelines for Labeling and User Information for RF Devices – KDB Publication 784748](#).

**Explanation:**The host system using this module, should have label in a visible area indicated the following texts: "Contains FCC ID: 2APT7AR41AP.

## 2.9 Information on test modes and additional testing requirements

Additional guidance for testing host products is given in KDB Publication 996369 D04 Module Integration Guide. Test modes should take into consideration different operational conditions for a stand-alone modular transmitter in a host, as well as for multiple simultaneously transmitting modules or other transmitters in a host product.

The grantee should provide information on how to configure test modes for host product evaluation for different operational conditions for a stand-alone modular transmitter in a host, versus with multiple, simultaneously transmitting modules or other transmitters in a host.

Grantees can increase the utility of their modular transmitters by providing special means, modes, or instructions that simulates or characterizes a connection by enabling a transmitter. This can greatly simplify a host manufacturer's determination that a module as installed in a host complies with FCC requirements.

**Explanation:** Yinuo-link can increase the utility of our modular transmitters by providing instructions that simulates or characterizes a connection by enabling a transmitter.

#### **2.10 Additional testing, Part 15 Subpart B disclaimer**

The grantee should include a statement that the modular transmitter is only FCC authorized for the specific rule parts (i.e., FCC transmitter rules) listed on the grant, and that the host product manufacturer is responsible for compliance to any other FCC rules that apply to the host not covered by the modular transmitter grant of certification. If the grantee markets their product as being Part 15

Subpart B compliant (when it also contains unintentional-radiator digital circuitry), then the grantee shall provide a notice stating that the final host product still requires Part 15 Subpart B compliance testing with the modular transmitter installed.

**Explanation:** The module without unintentional-radiator digital circuitry, so the module does not require an evaluation by FCC Part 15 Subpart B. The host should be evaluated by the FCC Subpart B.