

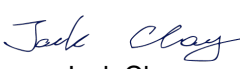

Prüfbericht-Nr.: <i>Test report no.:</i>	CN20WS3V (P15C-2.4G) 001	Auftrags-Nr.: <i>Order no.:</i>	238491635	Seite 1 von 28 Page 1 of 28
Kunden-Referenz-Nr.: <i>Client reference no.:</i>	N/A	Auftragsdatum: <i>Order date:</i>	2020-09-14	
Auftraggeber: <i>Client:</i>	Audeze LLC. 3410 S Susan st, Santa Ana, CA 92704, USA			
Prüfgegenstand: <i>Test item:</i>	Penrose Wireless Stereo Headset			
Bezeichnung / Typ-Nr.: <i>Identification / Type no.:</i>	Penrose P RX, Penrose X RX			
Auftrags-Inhalt: <i>Order content:</i>	FCC Part 15C Test report (2.4GHz)			
Prüfgrundlage: <i>Test specification:</i>	FCC 47CFR Part 15: Subpart C Section 15.247			
Wareneingangsdatum: <i>Date of sample receipt:</i>	2020-10-05			
Prüfmuster-Nr.: <i>Test sample no.:</i>	A002923011-047 A002923011-030			
Prüfzeitraum: <i>Testing period:</i>	2020-10-19 - 2020-11-03			
Ort der Prüfung: <i>Place of testing:</i>	EMC/RF Laboratory Taipei			
Prüflaboratorium: <i>Testing laboratory:</i>	Taipei Testing Laboratories			
Prüfergebnis*: <i>Test result*:</i>	Pass			
überprüft von: <i>reviewed by:</i>	genehmigt von: <i>authorized by:</i>			
Datum: <i>Date:</i> 2020-11-06	 Jack Chang		 Brenda Chen	
Stellung / Position:	Senior Project Manager		Senior Project Manager	
Sonstiges / Other:	The RF characteristics and PCB layout are the same, the only differences is color between two models.			
Zustand des Prüfgegenstandes bei Anlieferung: <i>Condition of the test item at delivery:</i>	Prüfmuster vollständig und unbeschädigt <i>Test item complete and undamaged</i>			
* Legende:	1 = sehr gut P(ass) = entspricht o.g. Prüfgrundlage(n)	2 = gut F(ail) = entspricht nicht o.g. Prüfgrundlage(n)	3 = befriedigend N/A = nicht anwendbar	4 = ausreichend N/T = nicht getestet
* Legend:	1 = very good P(ass) = passed a.m. test specification(s)	2 = good F(ail) = failed a.m. test specification(s)	3 = satisfactory N/A = not applicable	4 = sufficient N/T = not tested
Dieser Prüfbericht bezieht sich nur auf das o.g. Prüfmuster und darf ohne Genehmigung der Prüfstelle nicht auszugsweise vervielfältigt werden. Dieser Bericht berechtigt nicht zur Verwendung eines Prüfzeichens. <i>This test report only relates to the a. m. test sample. Without permission of the test center this test report is not permitted to be duplicated in extracts. This test report does not entitle to carry any test mark.</i>				

TEST SUMMARY

Report Section	FCC Clause	Test Item	Result
5.1.1	15.247(b) & 15.203	Antenna Requirement	Pass
5.1.2	15.247(b)(3)	Peak Output Power	Pass
5.1.3	15.247(a)(2)	6 dB Bandwidth	Pass
5.1.3	2.1049	99% Occupied Bandwidth	Pass
5.1.4	15.247(e)	Power Spectral Density	Pass
5.1.5	15.247(d)	Conducted Spurious Emissions and Band Edges	Pass
5.1.6	15.247(d) & 15.205 & 15.209	Radiated Spurious Emissions and Band Edges	Pass
5.2.1	15.207	Mains Conducted Emission	Pass
6.1	FCC KDB 447498 D01 v06	RF Exposure Compliance	Pass

Note: Determining compliance based on the results of the compliance measurement, not taking into account measurement instrumentation uncertainty.

Contents

HISTORY OF THIS TEST REPORT	5
1. GENERAL REMARKS	6
1.1 COMPLEMENTARY MATERIALS.....	6
1.2 DECISION RULE OF CONFORMITY	6
2. TEST SITES	7
2.1 TEST LABORATORY	7
2.2 TEST FACILITY.....	7
2.3 TRACEABILITY	8
2.4 CALIBRATION	8
2.5 MEASUREMENT UNCERTAINTY	8
3. GENERAL PRODUCT INFORMATION.....	9
3.1 PRODUCT FUNCTION AND INTENDED USE	9
3.2 SYSTEM DETAILS AND RATINGS.....	9
3.3 NOISE GENERATING AND NOISE SUPPRESSING PARTS	10
3.4 SUBMITTED DOCUMENTS.....	10
4. TEST SET-UP AND OPERATION MODES.....	11
4.1 PRINCIPLE OF CONFIGURATION SELECTION	11
4.2 TEST OPERATION AND TEST SOFTWARE.....	12
4.3 SPECIAL ACCESSORIES AND AUXILIARY EQUIPMENT	13
4.4 TEST SETUP DIAGRAM	14
5. TEST RESULTS	15
5.1 TRANSMITTER REQUIREMENT & TEST SUITES	15
5.1.1 <i>Antenna Requirement</i>	<i>15</i>
5.1.2 <i>Peak Output Power</i>	<i>16</i>
5.1.3 <i>6 dB Bandwidth and 99% Occupied Bandwidth.....</i>	<i>18</i>
5.1.4 <i>Power Spectral Density.....</i>	<i>19</i>
5.1.5 <i>Conducted Spurious Emissions and Frequency Band Edges Measured in 100kHz Bandwidth.....</i>	<i>20</i>
5.1.6 <i>Radiated Spurious Emissions and Band Edges</i>	<i>21</i>
5.2 MAINS EMISSION	26
5.2.1 <i>Mains Conducted Emission.....</i>	<i>26</i>
6. SAFETY HUMAN EXPOSURE.....	28
6.1 RF EXPOSURE COMPLIANCE	28
6.1.1 <i>SAR Test Exclusion Thresholds.....</i>	<i>28</i>

Prüfbericht - Nr.: CN20WS3V (P15C-2.4G) 001
Test Report No.

Seite 4 von 28
Page 4 of 28

APPENDIX A - TEST RESULT OF CONDUCTED

**APPENDIX B - TEST RESULT OF RADIATED SPURIOUS EMISSIONS & MAINS CONDUCTED
EMISSION**

APPENDIX SP - PHOTOGRAPHS OF TEST SETUP

APPENDIX EP - PHOTOGRAPHS OF EUT

Prüfbericht - Nr.: CN20WS3V (P15C-2.4G) 001
Test Report No.

Seite 5 von 28
Page 5 of 28

HISTORY OF THIS TEST REPORT

Report No.	Description	Date Issued
CN20WS3V (P15C-2.4G) 001	Original Release	2020-11-06

1. General Remarks

1.1 Complementary Materials

All attachments are integral parts of this test report. This applies especially to the following appendix:

Appendix A - Test Result of Conducted

Appendix B - Test Result of Radiated Spurious Emissions & Mains Conducted Emission

Appendix SP - Photographs of Test Setup

Appendix EP - Photographs of EUT

Applied Standard and Test Levels

Radio
FCC 47CFR Part 15: Subpart C Section 15.247
FCC 47CFR Part 2: Subpart J Section 2.1049
ANSI C63.10:2013
KDB 558074 D01 15.247 Meas Guidance v05r02
KDB 447498 D01 General RF Exposure Guidance v06

1.2 Decision Rule of Conformity

The decision rule of conformity of this test report is following the requirements of the requested standard in the quotation, and agreed among testing laboratory and manufacturer (applicant) to exclude the consideration of Measurement Uncertainty, unless it is required by the specific standard.

2. Test Sites

2.1 Test Laboratory

Taipei Testing Laboratories

11F. No.758, Sec. 4, Bade Rd., Songshan Dist.
Taipei City 105
Taiwan (R.O.C.)

2.2 Test Facility

Taipei Testing Laboratories

No.458-18, Sec. 2, Fenliao Rd., Linkou Dist.,
New Taipei City 244
Taiwan (R.O.C.)
FCC Registration No.: 226631
ISED Registration No.: 25563

2.3 Traceability

All measurement equipment calibrations are traceable to NML(Taiwan)/NIST(USA) or where calibration is performed outside Taiwan, to equivalent nationally recognized standards organizations.

2.4 Calibration

Equipment requiring calibration is calibrated periodically in a suitably accredited Calibration Lab. Additionally all equipment is verified for proper performance on a regular basis using in house standards or comparisons.

2.5 Measurement Uncertainty

All measurement uncertainty values are shown with a coverage factor of $k=2$ to indicate a 95% level of confidence.

Emission Measurement Uncertainty

Parameter	Uncertainty
Radiated Emission (9 kHz ~ 30 MHz)	± 1.15 dB
Radiated Emission (30 MHz ~ 200 MHz)	± 1.30 dB
Radiated Emission (200 MHz ~ 1 GHz)	± 1.30 dB
Radiated Emission (1 GHz ~ 18 GHz)	± 1.54 dB
Radiated Emission (18 GHz ~ 40 GHz)	± 2.52 dB
Mains Conducted Emission	± 1.65 dB

3. General Product Information

3.1 Product Function and Intended Use

The EUT is a Penrose Wireless Stereo Headset. It contains a Bluetooth and 2.4GHz compatible module enabling the user to communicate data through a Wireless interface.

For details refer to the User Guide, Data Sheet and Circuit Diagram.

3.2 System Details and Ratings

Basic Information of EUT

Item	EUT information
Kind of Equipment/Test Item	Penrose Wireless Stereo Headset
Type Identification	Penrose P RX, Penrose X RX
FCC ID	2APRZ-PENROSERX

Technical Specification of EUT

Item	EUT information
Operating Frequency	2403.35 MHz ~ 2479.35 MHz
Channel Spacing	2 MHz
Channel number	39
Operation Voltage	5Vdc (USB) 3.7 Vdc (Battery)
Modulation	Pi/4 DQPSK
Maximum Output Power (mW)	0.96
Antenna Information	Refer to 5.1.1
Accessory Device	Refer to 4.3

3.3 Noise Generating and Noise Suppressing Parts

Refer to the Circuit Diagram.

3.4 Submitted Documents

- Circuit Diagram
- Instruction Manual
- Rating Label
- Technical Description

4. Test Set-up and Operation Modes

4.1 Principle of Configuration Selection

The test modes were adapted accordingly in reference to the instructions for use.

During testing, Channel and Power Controlling Software provided by the customer was used to control the operating channel as well as the output power level. The RF output power selection is for the setting of RF output expected by the customer and is going to be fixed on the firmware of the final end product. Bluetooth function and 2.4GHz function will not transmitter at same time.

Table for Parameters of Test Software Setting

	Frequency (MHz)	Power Setting
Ant 1	2403.35	0x00
	2441.35	0x00
	2479.35	0x01
Ant 2	2403.35	0x00
	2441.35	0x00
	2479.35	0x00

4.2 Test Operation and Test Software

Setup for testing: Test samples are provided with a USB interface which makes it possible to control them through a test software installed on a notebook computer.

This software was running on the laptop computer connected to the EUT. It was used to enable the operation modes listed as below.

Test Software	AVServe.exe
---------------	-------------

The samples were used as follows:

A002923011-047

A002923011-030

Full test was applied on all test modes, but only worst case was shown.

EUT Configure Mode	Applicable To			Mains Conducted Emission	Description
	Antenna Port Conducted Measurement	Radiated Spurious Emissions above 1 GHz	Radiated Spurious Emissions below 1 GHz		
-	√	√	√	√	-

Note:

1. The EUT had been pre-tested on the positioned of each 3 axis. The worst case was found when position on **Z-plane**.
2. "-" means no effect.

Antenna Port Conducted Measurement

- Pre-Scan full test was applied on all test modes, but only worst case was shown.
- Following channel(s) was (were) selected for the final test as listed below.

EUT Configure Mode	Available Frequency (MHz)	Tested Frequency (MHz)
ANT 1 / ANT 2	2403.35 to 2479.35	2403.35, 2441.35, 2479.35

Radiated Spurious Emissions (Above 1 GHz)

- Pre-Scan full test was applied on all test modes, but only worst case was shown.
- Following channel(s) was (were) selected for the final test as listed below.

EUT Configure Mode	Available Frequency (MHz)	Tested Frequency (MHz)
ANT 1 / ANT 2	2403.35 to 2479.35	2403.35, 2441.35, 2479.35

Radiated Spurious Emissions (Below 1 GHz)

- Pre-Scan full test was applied on all test modes, but only worst case was shown.
- Following channel(s) was (were) selected for the final test as listed below.

EUT Configure Mode	Available Frequency (MHz)	Tested Frequency (MHz)
ANT 2	2403.35 to 2479.35	2479.35

Mains Conducted Emission

- Pre-Scan full test was applied on all test modes, but only worst case was shown.
- Following channel(s) was (were) selected for the final test as listed below.

EUT Configure Mode	Available Frequency (MHz)	Tested Frequency (MHz)
-	2403.35 to 2479.35	2479.35

Test Condition

Test Item	Ambient Temperature	Relative Humidity	Tested by
Conducted Measurement	22-26 °C	55-70 %	Chun Wu
Radiated Spurious Emissions above 1 GHz	22 °C	55.4 %	Simon Tsai
Radiated Spurious Emissions below 1 GHz	22 °C	55.4 %	Simon Tsai
Mains Conducted Emission	26 °C	65 %	Kay Wu

4.3 Special Accessories and Auxiliary Equipment

The product has been tested together with the following additional accessories:

Accessory of EUT

No.	Product	Brand	Model	Description
A	USB Cable	AUDEZE	Penrose P RX Penrose X RX	300 cm shielded cable w/o core
-	Microphone	AUDEZE	Penrose P RX Penrose X RX	--

Support Unit

Support Unit					
No.	Description	Brand	Model	S/N	Remark
1	Notebook	HP	15s-du0007TX	CND93662VF	--
2	Adapter	HP	TPN-CA16	N/A	--

Interface Cable					
No.	Description	Shielded Type	Ferrite Core (Qty)	Length (cm)	Remark
2	Adapter Cable	NO	0	180	--

4.4 Test Setup Diagram

<Radiated Spurious Emissions mode>

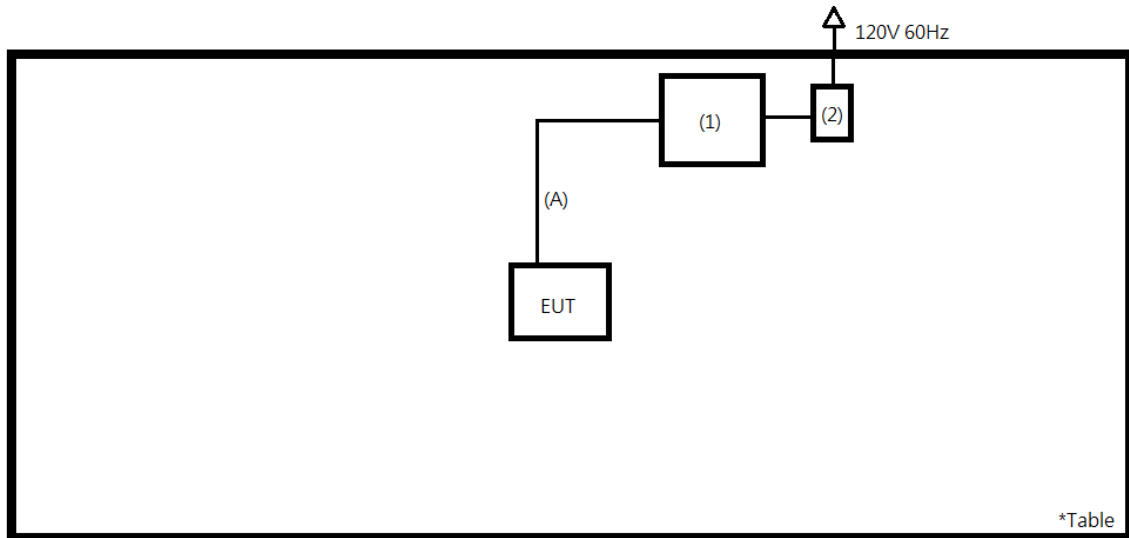

<Mains Conducted Emission mode>

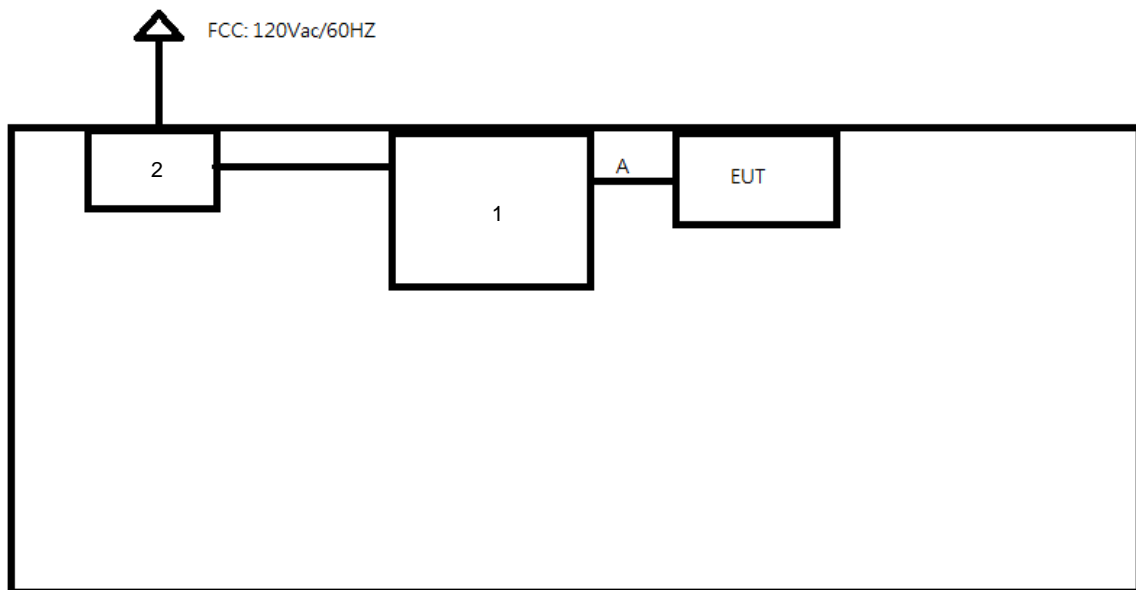

5. Test Results

5.1 Transmitter Requirement & Test Suites

5.1.1 Antenna Requirement

Requirement Use of approved antennas only

According to the manufacturer declaration, the EUT has an antenna with a directional gain of 3.8 dBi. The antenna is a chip antenna with no possibility of replacement with a non-approved antenna by the end-user. Therefore, the EUT is considered to comply with this provision.

There are two chip antennas (Ant 1 and Ant 2) use for 2.4GHz function and supports SISO mode only. PIFA (Ant 3) is use for Bluetooth function.

Bluetooth function and 2.4GHz function will not transmitter at same time.

Refer to EUT photo for details.

5.1.2 Peak Output Power

Limit 1 watt (30 dBm)

Kind of Test Site Shielded room

Test Setup

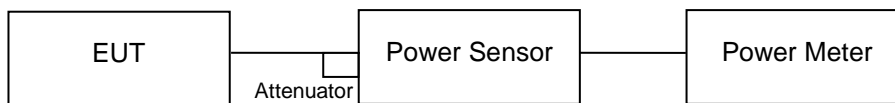

Test Instruments

Kind of Equipment	Manufacturer	Type	S/N	Calibration Date	Calibration Due Date
Power Meter	Anritsu	ML2495A	1901008	2020/4/6	2021/4/5
Power Sensor	Anritsu	MA2411B	1725269	2020/4/7	2021/4/6

Test Procedures

A peak power sensor was used on the output port of the EUT. A power meter was used to read the response of the peak power sensor. Record the power level.

Average power sensor was used to perform output power measurement, trigger and gating function of wide band power meter is enabled to measure max output power of TX on burst. Duty factor is not added to measured value.

Test Result
Peak Output Power
<Ant 1>

Channel	Channel Frequency	Peak Output Power		Limit (dBm)
	(MHz)	(dBm)	(mW)	
Low Channel	2403.35	-1.52	0.70	30
Middle Channel	2441.35	-1.04	0.79	30
High Channel	2479.35	-1.63	0.69	30

<Ant 2>

Channel	Channel Frequency	Peak Output Power		Limit (dBm)
	(MHz)	(dBm)	(mW)	
Low Channel	2403.35	-0.19	0.96	30
Middle Channel	2441.35	-0.68	0.86	30
High Channel	2479.35	-1.13	0.77	30

Average Power
<Ant 1>

Channel	Channel Frequency	Average Power	
	(MHz)	(dBm)	(mW)
Low Channel	2403.35	-3.19	0.48
Middle Channel	2441.35	-2.66	0.54
High Channel	2479.35	-3.51	0.45

<Ant 2>

Channel	Channel Frequency	Average Power	
	(MHz)	(dBm)	(mW)
Low Channel	2403.35	-1.78	0.66
Middle Channel	2441.35	-2.30	0.59
High Channel	2479.35	-2.80	0.52

5.1.3 6 dB Bandwidth and 99% Occupied Bandwidth

Limit The minimum 6 dB bandwidth shall be at least 500 kHz.

Kind of Test Site Shielded room

Test Setup

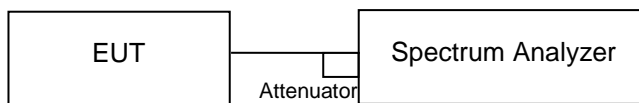

Test Instruments

Kind of Equipment	Manufacturer	Type	S/N	Calibration Date	Calibration Due Date
Spectrum Analyzer	R&S	FSV40	101512	2020/2/18	2021/2/16

Test Procedure

- a. Set resolution bandwidth (RBW) = 100 kHz
- b. Set the video bandwidth (VBW) $\geq 3 \times$ RBW, Detector = Peak.
- c. Trace mode = max hold.
- d. Sweep = auto couple.
- e. Measure the maximum width of the emission that is constrained by the frequencies associated with the two amplitude points (upper and lower) that are attenuated by 6 dB relative to the maximum level measured in the fundamental emission.
- f. For 99% occupied bandwidth measurement, the transmitter output was connected to the spectrum analyzer through an attenuator. The bandwidth of the fundamental frequency was measured by spectrum analyzer with resolution bandwidth in the range of 1% to 5% of the anticipated emission bandwidth, and a video bandwidth at least 3x the resolution bandwidth and set the detector to PEAK. The width of a frequency band such that, below the lower and above the upper frequency limits, the mean powers emitted are each equal to a specified percentage 0.5% of the total mean power of a given emission.

Test Results

Please refer to Appendix A.

5.1.4 Power Spectral Density

Limit

The power spectral density shall not be greater than 8 dBm in any 3 kHz band.

Kind of Test Site Shielded room

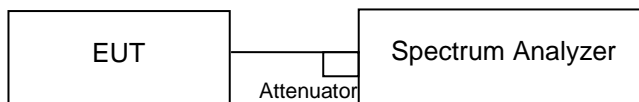
Test Setup

Test Instruments

Kind of Equipment	Manufacturer	Type	S/N	Calibration Date	Calibration Due Date
Spectrum Analyzer	R&S	FSV40	101512	2020/2/18	2021/2/16

Test Procedure

- a. Set analyzer center frequency to DTS channel center frequency.
- b. Set the span to 1.5 times the DTS bandwidth.
- c. Set the RBW to: $3 \text{ kHz} \leq \text{RBW} \leq 100 \text{ kHz}$.
- d. Set the VBW $\geq 3 \times \text{RBW}$.
- e. Detector = peak.
- f. Sweep time = auto couple.
- g. Trace mode = max hold.
- h. Allow trace to fully stabilize.
- i. Use the peak marker function to determine the maximum amplitude level within the RBW.

Test Results

Please refer to Appendix A.

5.1.5 Conducted Spurious Emissions and Frequency Band Edges Measured in 100kHz Bandwidth

Limit

20dB (below that in the 100 kHz bandwidth within the band that contains the highest level of the desired power.)

Kind of Test Site Shielded room

Test Setup

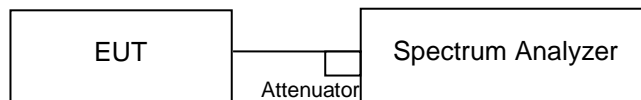

Test Instruments

Kind of Equipment	Manufacturer	Type	S/N	Calibration Date	Calibration Due Date
Spectrum Analyzer	R&S	FSV40	101512	2020/2/18	2021/2/16

Test Procedure

Measurement procedure REF

1. Set the RBW = 100 kHz.
2. Set the VBW \geq 300 kHz.
3. Detector = peak.
4. Sweep time = auto couple.
5. Trace mode = max hold.
6. Allow trace to fully stabilize.
7. Use the peak marker function to determine the maximum power level in any 100 kHz band segment within the fundamental EBW.

Measurement procedure OOBE

1. Set RBW = 100 kHz.
2. Set VBW \geq 300 kHz.
3. Detector = peak.
4. Sweep = auto couple.
5. Trace Mode = max hold.
6. Allow trace to fully stabilize.
7. Use the peak marker function to determine the maximum amplitude level.

Test Results

Please refer to Appendix A.

5.1.6 Radiated Spurious Emissions and Band Edges

Limit

Radiated emissions which fall in the restricted bands, as defined in §15.205(a), must comply with the radiated emission limits specified in §15.209(a).

Emissions radiated outside the restricted and authorized frequency bands must either comply with the radiated emission limits specified for the restricted bands or in §15.247(d).

Kind of Test Site 3m Semi-Anechoic Chamber

Test Setup

<Radiated Emissions below 30 MHz>

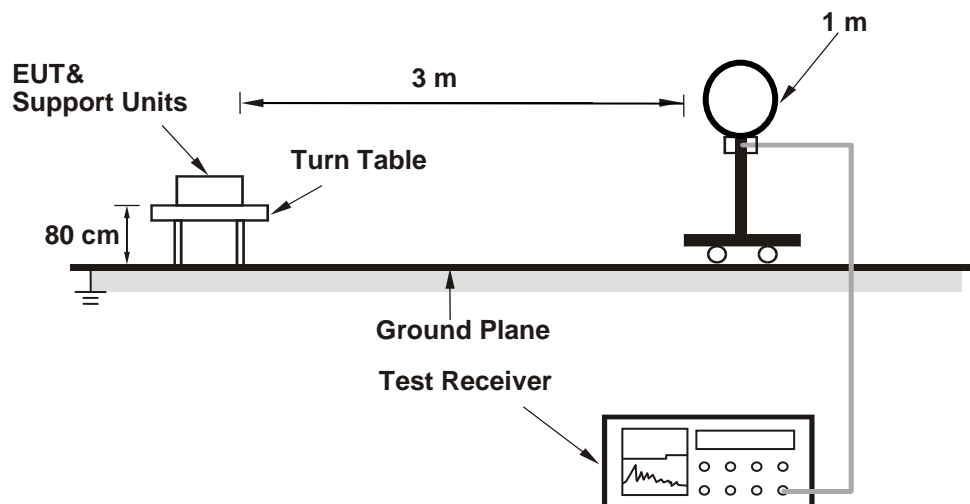

<Radiated Emissions 30 MHz to 1 GHz>

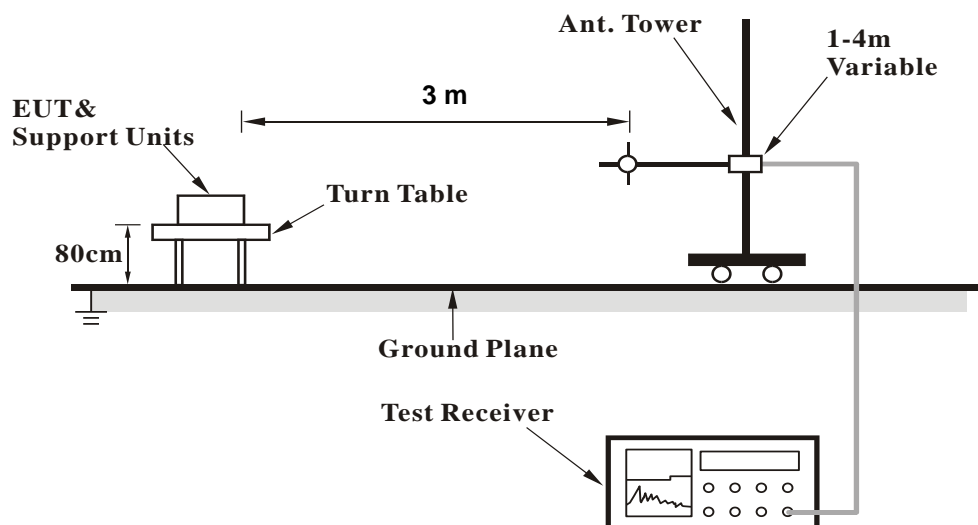

<Radiated Emissions above 1 GHz>

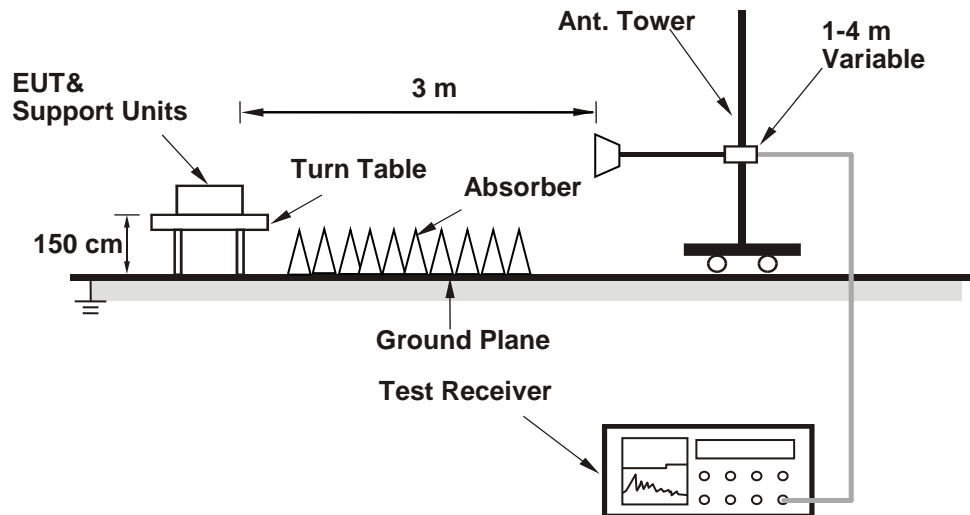

For the actual test configuration, please refer to the attached file (Test Setup Photo).

Test Instruments

Kind of Equipment	Manufacturer	Type	S/N	Calibration Date	Calibration Due Date
Signal Analyzer	R&S	FSV40	101508	2020/3/16	2021/3/15
Receiver	R&S	ESR7	102108	2020/4/22	2021/4/21
Bilog Antenna	SCHWARZBECK	VULB-9168	00951	2020/2/14	2021/2/13
Horn Antenna	ETS-Lindgren	3117	00218930	2019/12/6	2020/12/5
LF-AMP	Agilent	8447D	2944A10772	2020/2/11	2021/2/10
HF-AMP + AC source	EMCI	EMC051845SE	980633	2020/2/17	2021/2/16
HF-AMP + AC source	EMCI	EMC184045SE	980657	2020/2/17	2021/2/16
Horn Antenna	SCHWARZBECK	BBHA 9170	00887	2020/4/10	2021/4/9
Microwave Cable	HUBER+SUHNER	SUCOFLEX 104EA	800056/4EA	2020/3/25	2021/3/24
Microwave Cable	HUBER+SUHNER	SUCOFLEX 104	804680/4	2020/3/25	2021/3/24
Microwave Cable	HUBER+SUHNER	SUCOFLEX 104	MY37202/4	2020/3/25	2021/3/24
Microwave Cable	HUBER+SUHNER	SUCOFLEX 102EA	800898/2EA	2020/4/22	2021/4/21
Microwave Cable	HUBER+SUHNER	SUCOFLEX 102EA	800901/2EA	2020/4/22	2021/4/21
Microwave Cable	HUBER+SUHNER	SUCOFLEX 102EA	801027/2EA	2020/4/22	2021/4/21
Loop Antenna	Chance Most	EMCILPA600 +calibration	287	2020/1/9	2021/1/8

Test Procedures**For Radiated Emissions below 30 MHz**

- a. The EUT was placed on the top of a rotating table 0.8 meters above the ground at a 3 meter chamber room. The table was rotated 360 degrees to determine the position of the highest radiation.
- b. The EUT was set 3 meters away from the interference-receiving antenna, which was mounted on the top of a variable-height antenna tower.
- c. Parallel, perpendicular, and ground-parallel orientations of the antenna are set to make the measurement.
- d. For each suspected emission, the EUT was arranged to its worst case and the rotatable table was turned from 0 degrees to 360 degrees to find the maximum reading.
- e. The test-receiver system was set to Quasi-Peak Detect Function and Specified Bandwidth with Maximum Hold Mode.

Note:

1. The resolution bandwidth and video bandwidth of test receiver/spectrum analyzer is 9 kHz at frequency below 30 MHz.
2. All modes of operation were investigated and the worst-case emissions are reported.

For Radiated Emissions above 30 MHz

- a. The EUT was placed on the top of a rotating table 0.8 meters (for 30 MHz ~ 1 GHz) / 1.5 meters (for above 1 GHz) above the ground at 3 meter chamber room for test. The table was rotated 360 degrees to determine the position of the highest radiation.
- b. The EUT was set 3 meters away from the interference-receiving antenna, which was mounted on the top of a variable-height antenna tower.
- c. The height of antenna is varied from one meter to four meters above the ground to determine the maximum value of the field strength. Both horizontal and vertical polarizations of the antenna are set to make the measurement.
- d. For each suspected emission, the EUT was arranged to its worst case and then the antenna was tuned to heights from 1 meter to 4 meters and the rotatable table was turned from 0 degrees to 360 degrees to find the maximum reading.
- e. The test-receiver system was set to quasi-peak detect function and specified bandwidth with maximum hold mode when the test frequency is below 1 GHz.
- f. The test-receiver system was set to peak and average detected function and specified bandwidth with maximum hold mode when the test frequency is above 1 GHz. If the peak reading value also meets average limit, measurement with the average detector is unnecessary.

Note:

1. The resolution bandwidth and video bandwidth of test receiver/spectrum analyzer is 120 kHz for Quasi-peak detection (QP) or Peak detection (PK) at frequency below 1 GHz.
2. The resolution bandwidth of test receiver/spectrum analyzer is 1 MHz and the video bandwidth is 3 MHz for Peak detection (PK) at frequency above 1 GHz.
3. The resolution bandwidth of test receiver/spectrum analyzer is 1 MHz and the video bandwidth is $\geq 1/T$ (Duty cycle < 98 %) or 10 Hz (Duty cycle ≥ 98 %) for Average detection (AV) at frequency above 1 GHz.
4. All modes of operation were investigated and the worst-case emissions are reported.
5. The Radiated Emissions testing was performed in the X, Y and Z axis orientation. The worst-case Axis orientation is recorded in this test report.

Prüfbericht - Nr.: **CN20WS3V (P15C-2.4G) 001**
Test Report No.

Seite 25 von 28
Page 25 of 28

Test Results

Factor (dB/m) = Antenna Factor (dB/m) + Cable Loss (dB)
Level (dBuV/m) = Reading (dBuV) + Factor (dB/m)

Please refer to Appendix B.

5.2 Mains Emission

5.2.1 Mains Conducted Emission

Limit

Mains Conducted Emission as defined in §15.207 must comply with the mains conducted emission limits.

Kind of Test Site Shielded room

Test Setup

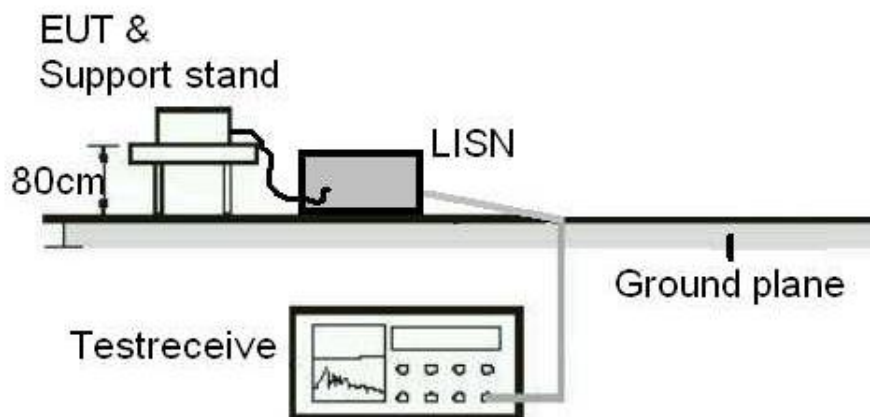

Test Instruments

Kind of Equipment	Manufacturer	Type	S/N	Calibration Date	Calibration Due Date
EMI Test Receiver	Rohde & Schwarz	ESR 7	102114	2020/04/13	2021/04/13
Two-Line V-Network (for EUT)	Rohde & Schwarz	ENV216	101262	2020/08/04	2021/08/04
Pulse Limiter	Schwarzbeck	VTSD 9561 F-N	00660	2020/02/24	2021/02/24
Test Software	Audix	e3	Ver. 9	N/A	N/A

Test Procedures

- a. The EUT was placed 0.4 meters from the conducting wall of the shielded room with EUT being connected to the power mains through a line impedance stabilization network (LISN). Other support units were connected to the power mains through another LISN. The two LISNs provide 50 ohm/50 uH of coupling impedance for the measuring instrument.
- b. Both lines of the power mains connected to the EUT were checked for maximum conducted interference.
- c. The frequency range from 150 kHz to 30 MHz was searched. Emission levels under (Limit – 20 dB) was not recorded.

Note: The resolution bandwidth and video bandwidth of test receiver is 9 kHz for quasi-peak detection (QP) and average detection (AV) at frequency 0.15 MHz – 30 MHz.

Test Results

Please refer to Appendix B.

6. Safety Human Exposure

6.1 RF Exposure Compliance

6.1.1 SAR Test Exclusion Thresholds

Results

Since the maximum output power of the transmitter is $0.66 \text{ mW} < 10 \text{ mW}$ (Distance: 5 mm), hence the EUT is excluded from SAR evaluation according to FCC KDB publication 447498 D01: Mobile Portable RF Exposure.

Appendix A: Test Results of Conducted Test

Test Result of 6 dB Bandwidth

ANT 1

Channel	Channel Frequency (MHz)	6 dB Bandwidth (kHz)	Limit (kHz)	Result
Low Channel	2403.35	1418.60	> 500	Pass
Middle Channel	2441.35	1418.58	> 500	Pass
High Channel	2479.35	1433.60	> 500	Pass

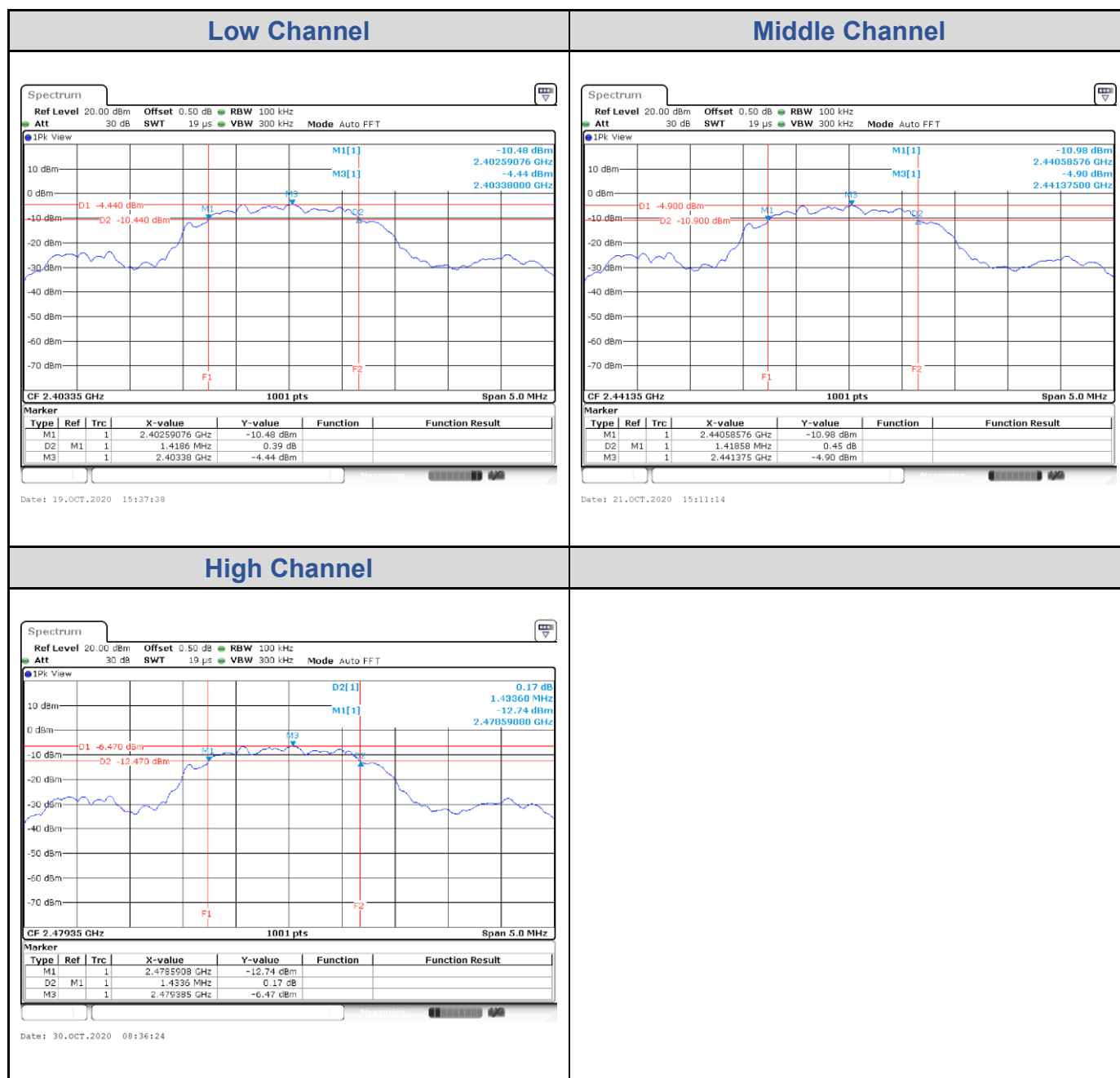

ANT 2

Channel	Channel Frequency (MHz)	6 dB Bandwidth (kHz)	Limit (kHz)	Result
Low Channel	2403.35	1433.60	> 500	Pass
Middle Channel	2441.35	1433.60	> 500	Pass
High Channel	2479.35	1433.60	> 500	Pass

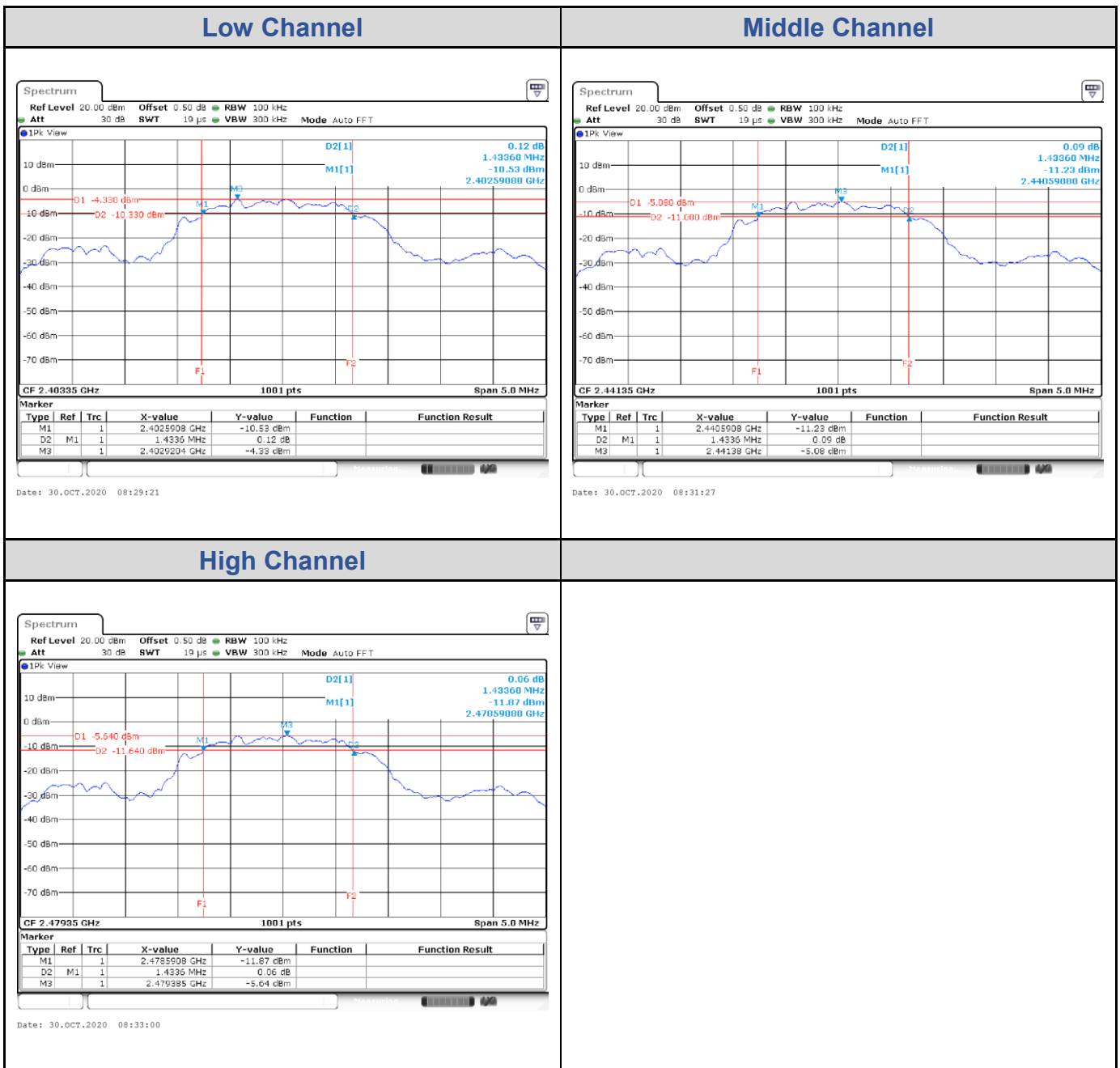

Test Result of 99% Occupied Bandwidth

ANT 1

Channel	Channel Frequency (MHz)	99% Bandwidth (MHz)
Low Channel	2403.35	2.797
Middle Channel	2441.35	2.772
High Channel	2479.35	2.750

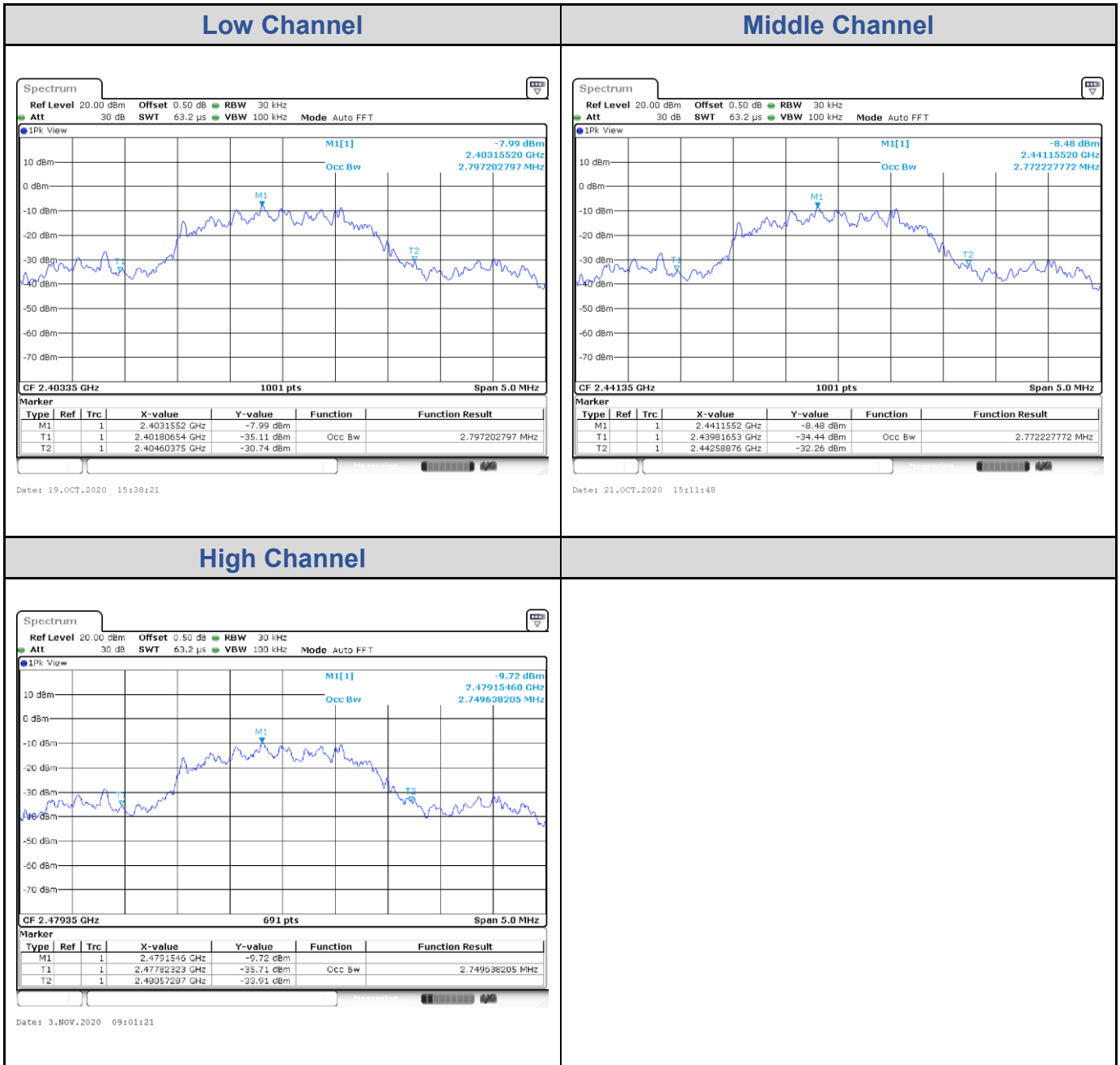

ANT 2

Channel	Channel Frequency (MHz)	99% Bandwidth (MHz)
Low Channel	2403.35	2.916
Middle Channel	2441.35	2.829
High Channel	2479.35	2.764

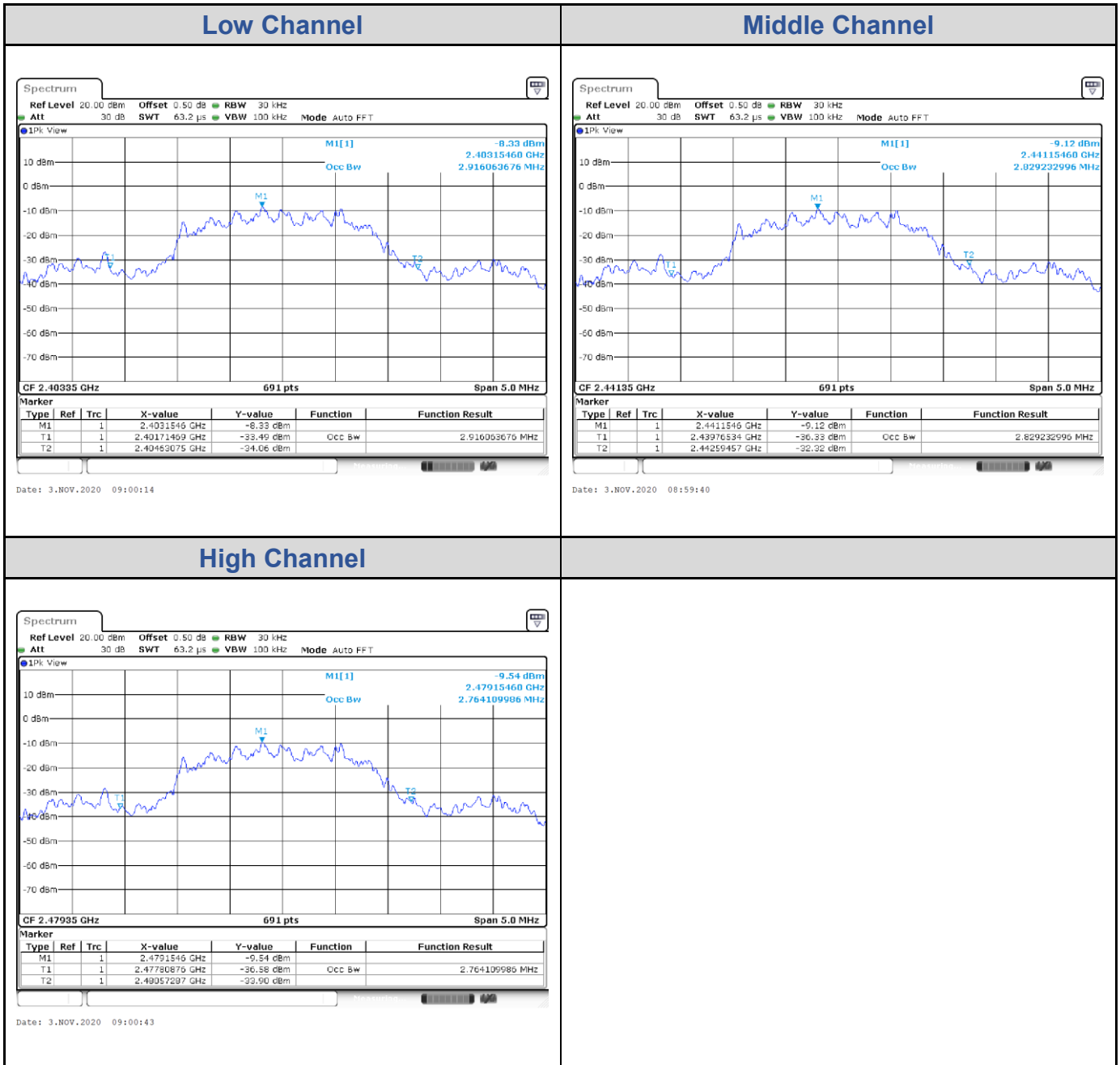

Test Result of Power Spectral Density

ANT 1

Channel	Channel Frequency (MHz)	Power Density (dBm/3kHz)	Limit (dBm/3kHz)	Result
Low Channel	2403.35	-19.22	8	Pass
Middle Channel	2441.35	-19.93	8	Pass
High Channel	2479.35	-21.36	8	Pass

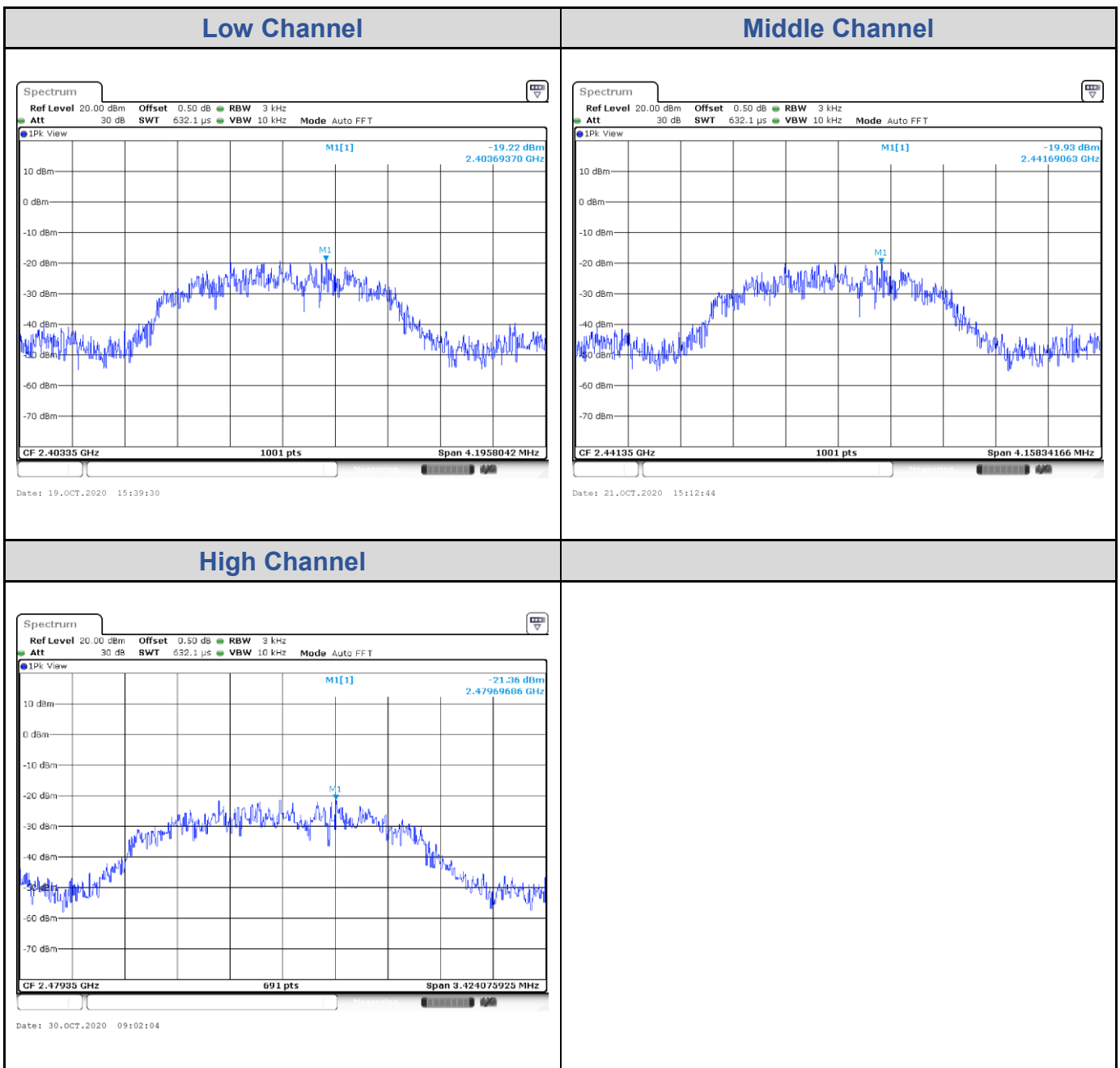

ANT 2

Channel	Channel Frequency (MHz)	Power Density (dBm/3kHz)	Limit (dBm/3kHz)	Result
Low Channel	2403.35	-19.31	8	Pass
Middle Channel	2441.35	-20.05	8	Pass
High Channel	2479.35	-20.56	8	Pass

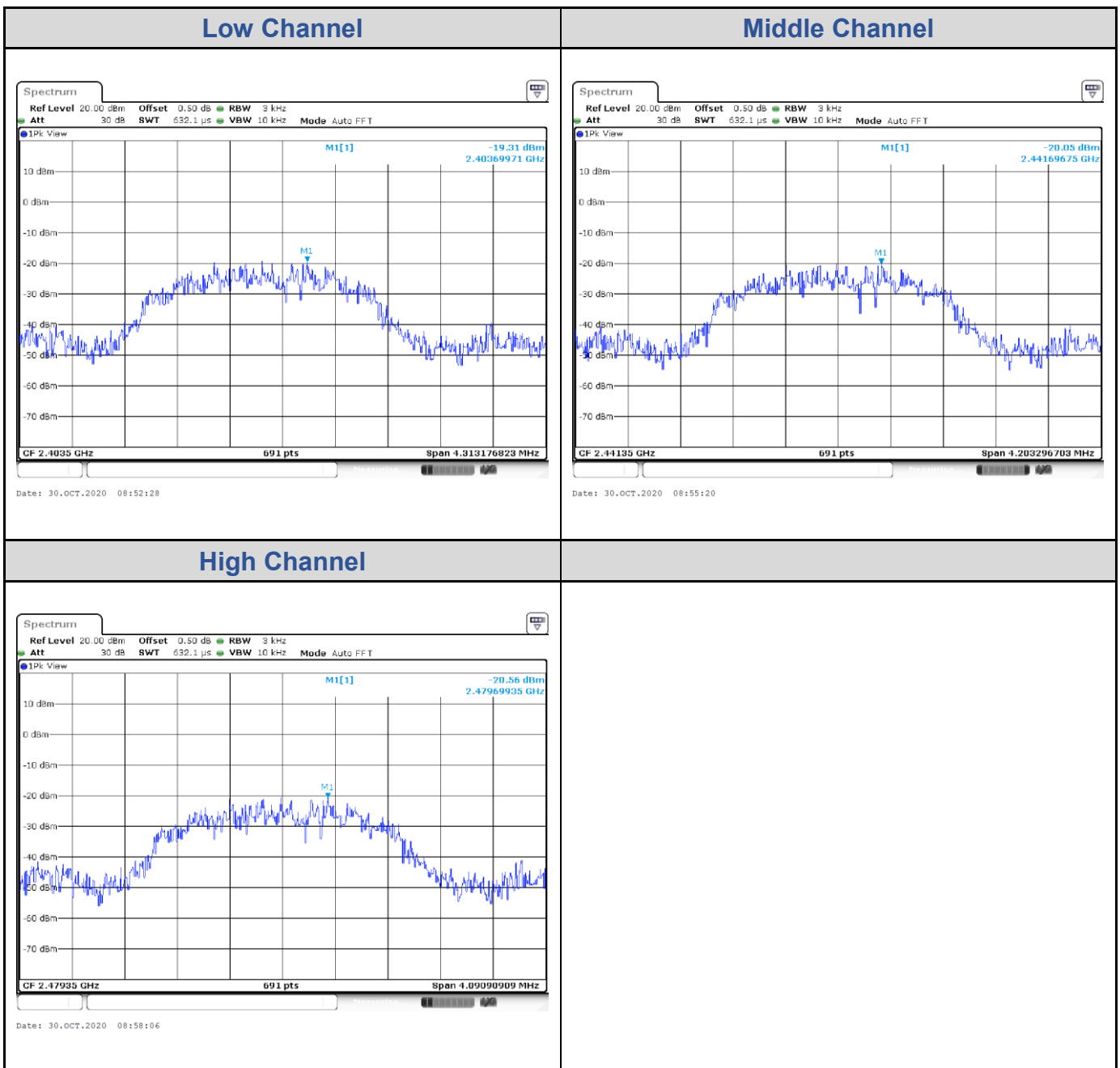

Test Result of Conducted Spurious Emissions, Tx Mode

ANT 1

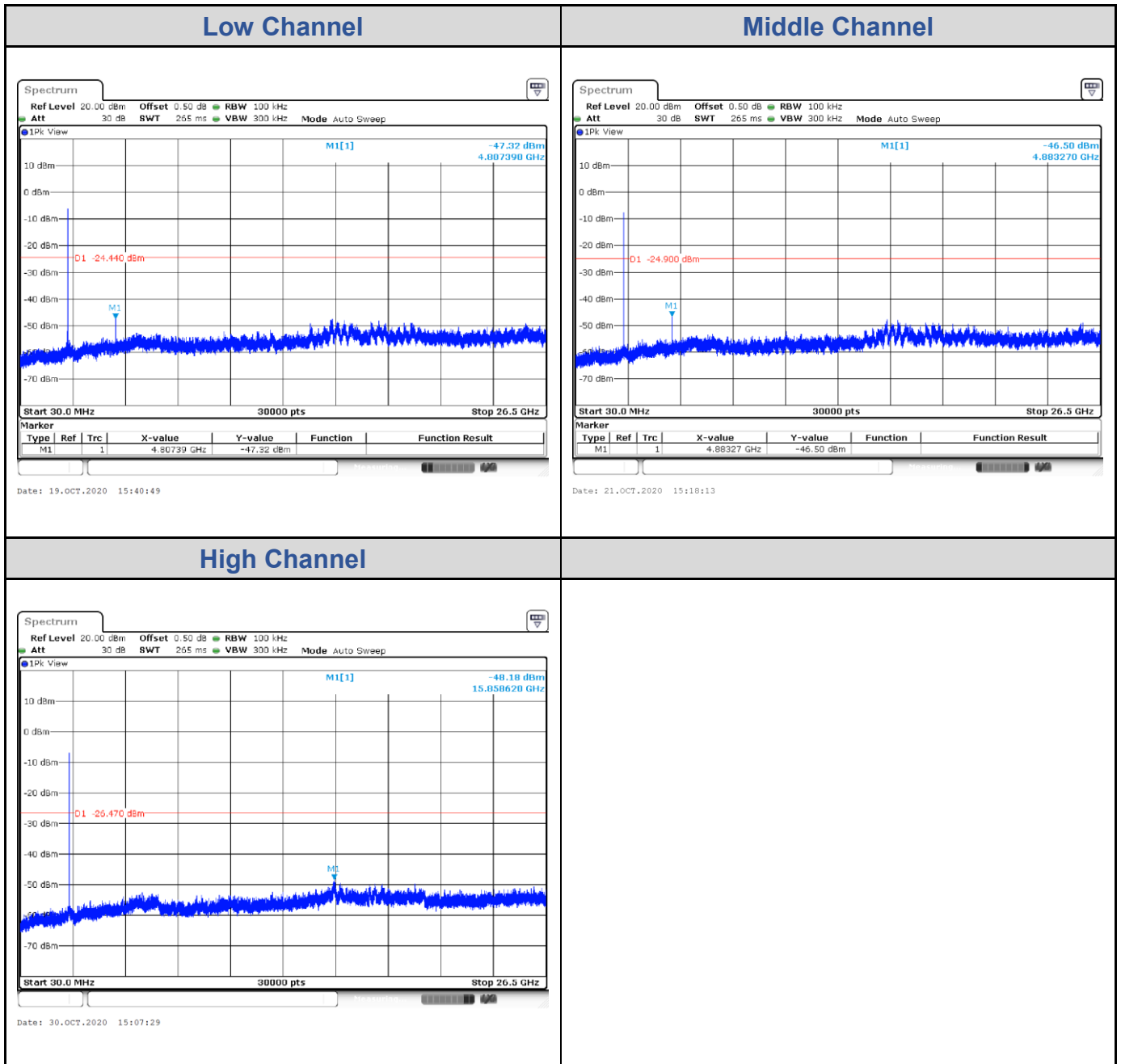

ANT 2

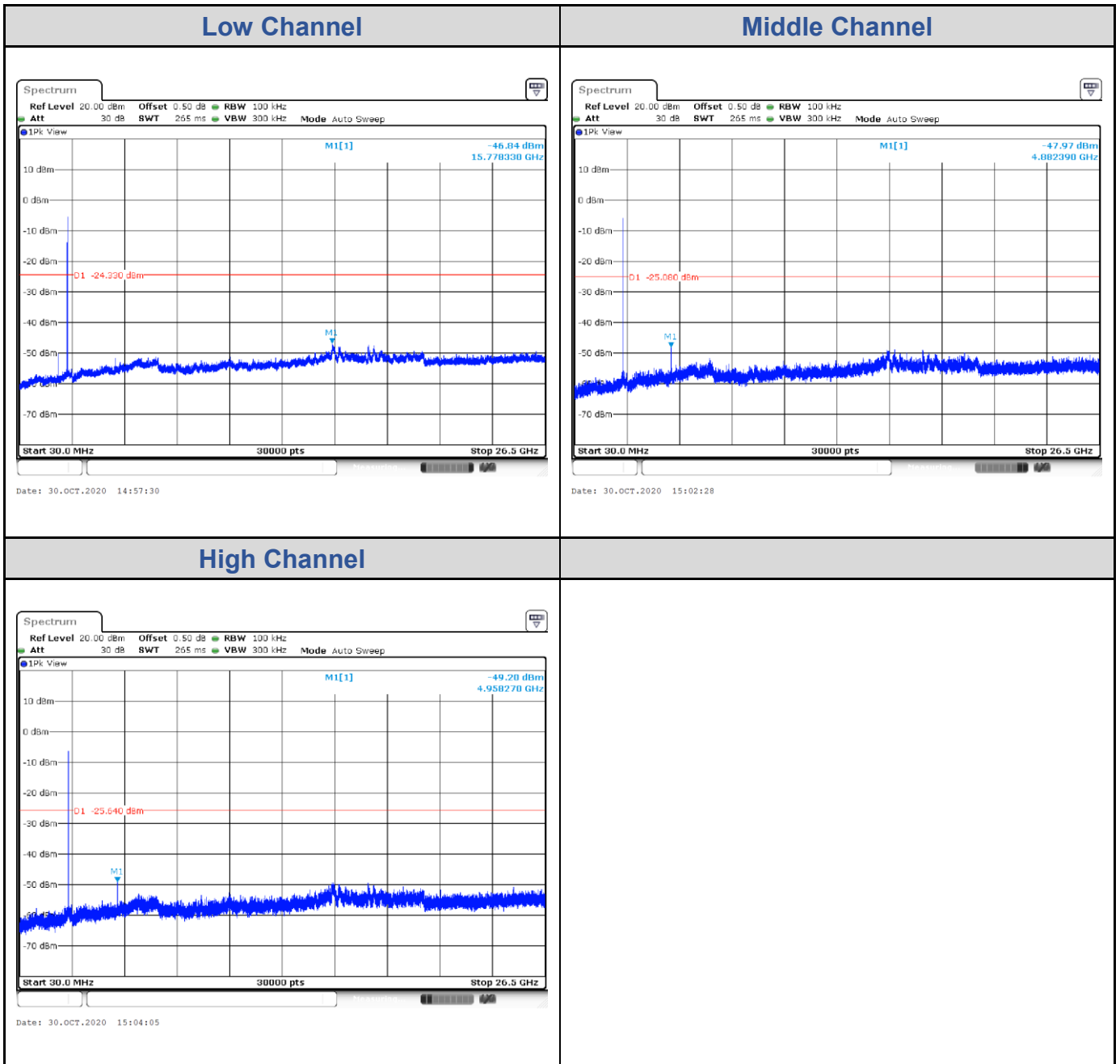

Test Result of Conducted Band Edge, Tx Mode

ANT 1

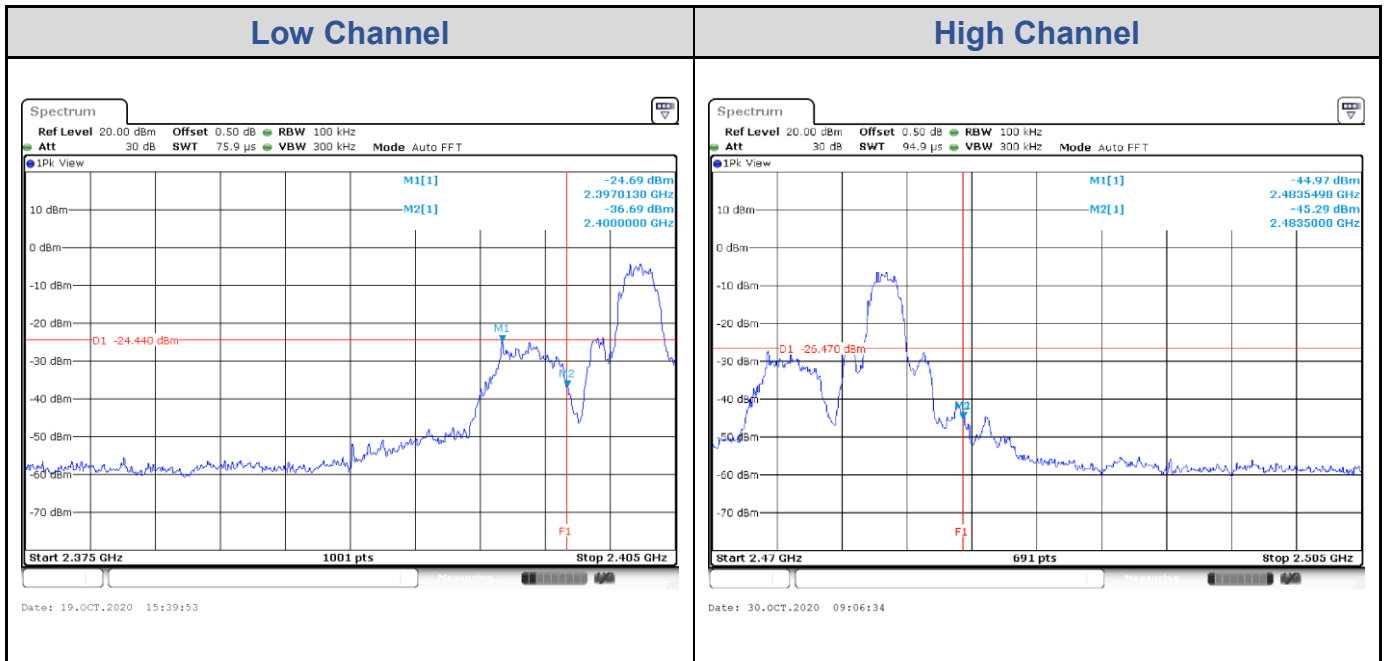

ANT 2

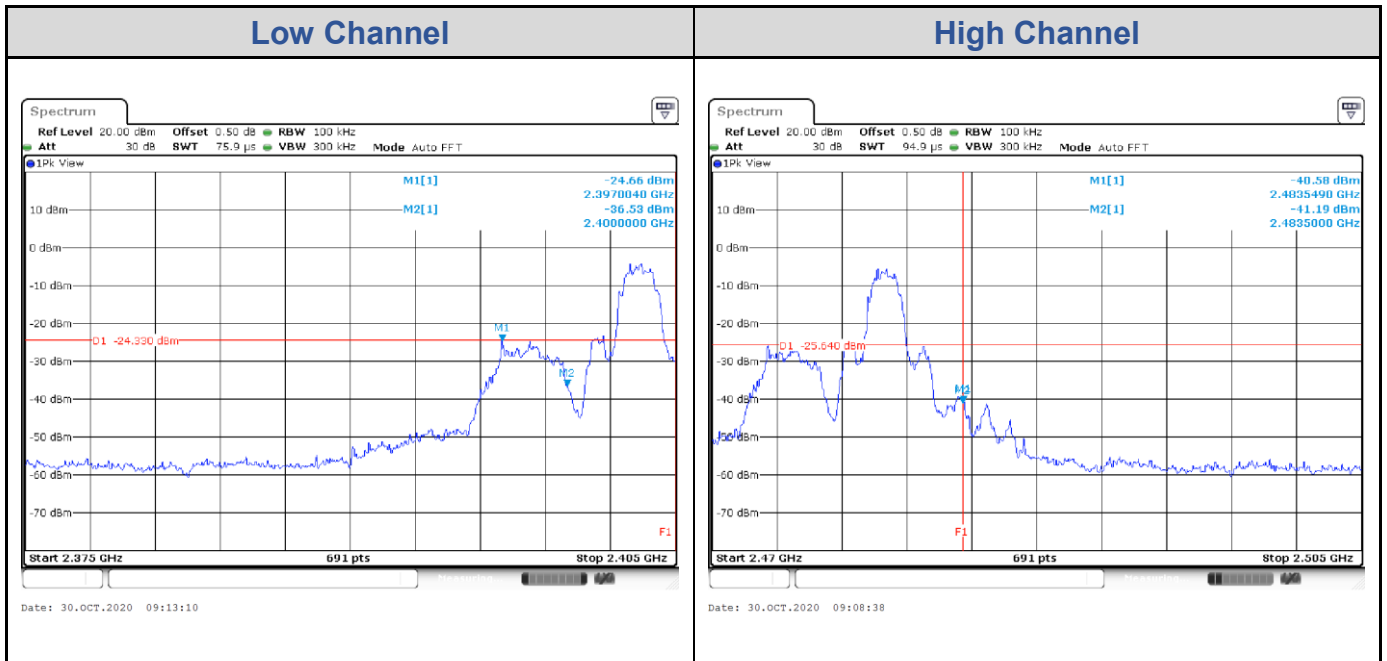

Appendix B: Test Results of Radiated Spurious Emissions & Mains

Conducted Emission Test

Band Edges, 2.31GHz ~ 2.9GHz

ANT 1																																																																																																					
Low Channel (Horizontal) Peak	Low Channel (Vertical) Peak																																																																																																				
<div style="text-align: right; font-size: small;"> TÜV Rheinland Taiwan Ltd. No. 458-18, Sec. 2, Fenhiao, Linkou Dist., New Taipei City 244, Taiwan(R.O.C.) Tel: +886-2172-1000 Fax: +886-2172-1322 </div> <div style="text-align: center; margin-top: 20px;"> </div> <div style="text-align: right; font-size: x-small; margin-top: 10px;"> Date: 2020-10-29 </div> <table border="1" style="width:100%; border-collapse: collapse; font-size: x-small; margin-top: 10px;"> <thead> <tr> <th>Freq</th> <th>Level</th> <th>Read</th> <th>Limit</th> <th>Over</th> <th>APos</th> <th>TPos</th> <th>Remark</th> <th>Pol/Phase</th> <th>Note</th> </tr> <tr> <th>MHz</th> <th>dBuV/m</th> <th>dBuV</th> <th>dB/m</th> <th>dBuV/m</th> <th>dB</th> <th>cm</th> <th>deg</th> <th></th> <th></th> </tr> </thead> <tbody> <tr> <td>1</td> <td>2339.33</td> <td>52.48</td> <td>15.31</td> <td>37.17</td> <td>74.00</td> <td>-21.52</td> <td>100</td> <td>233 Peak</td> <td>Horizontal</td> </tr> <tr> <td>2 *</td> <td>2483.35</td> <td>93.45</td> <td>56.07</td> <td>37.38</td> <td>74.00</td> <td>19.45</td> <td>100</td> <td>233 Peak</td> <td>Horizontal</td> </tr> <tr> <td>3</td> <td>2856.30</td> <td>54.02</td> <td>15.92</td> <td>38.10</td> <td>74.00</td> <td>-19.98</td> <td>100</td> <td>233 Peak</td> <td>Horizontal</td> </tr> </tbody> </table>	Freq	Level	Read	Limit	Over	APos	TPos	Remark	Pol/Phase	Note	MHz	dBuV/m	dBuV	dB/m	dBuV/m	dB	cm	deg			1	2339.33	52.48	15.31	37.17	74.00	-21.52	100	233 Peak	Horizontal	2 *	2483.35	93.45	56.07	37.38	74.00	19.45	100	233 Peak	Horizontal	3	2856.30	54.02	15.92	38.10	74.00	-19.98	100	233 Peak	Horizontal	<div style="text-align: right; font-size: small;"> TÜV Rheinland Taiwan Ltd. No. 458-18, Sec. 2, Fenhiao, Linkou Dist., New Taipei City 244, Taiwan(R.O.C.) Tel: +886-2172-1000 Fax: +886-2172-1322 </div> <div style="text-align: center; margin-top: 20px;"> </div> <div style="text-align: right; font-size: x-small; margin-top: 10px;"> Date: 2020-10-29 </div> <table border="1" style="width:100%; border-collapse: collapse; font-size: x-small; margin-top: 10px;"> <thead> <tr> <th>Freq</th> <th>Level</th> <th>Read</th> <th>Limit</th> <th>Over</th> <th>APos</th> <th>TPos</th> <th>Remark</th> <th>Pol/Phase</th> <th>Note</th> </tr> <tr> <th>MHz</th> <th>dBuV/m</th> <th>dBuV</th> <th>dB/m</th> <th>dBuV/m</th> <th>dB</th> <th>cm</th> <th>deg</th> <th></th> <th></th> </tr> </thead> <tbody> <tr> <td>1</td> <td>2387.50</td> <td>53.39</td> <td>16.06</td> <td>37.33</td> <td>74.00</td> <td>-20.61</td> <td>235</td> <td>236 Peak</td> <td>Vertical</td> </tr> <tr> <td>2 *</td> <td>2483.35</td> <td>96.55</td> <td>59.17</td> <td>37.38</td> <td>74.00</td> <td>22.55</td> <td>235</td> <td>236 Peak</td> <td>Vertical</td> </tr> <tr> <td>3</td> <td>2799.53</td> <td>54.50</td> <td>16.59</td> <td>37.91</td> <td>74.00</td> <td>-19.50</td> <td>235</td> <td>236 Peak</td> <td>Vertical</td> </tr> </tbody> </table>	Freq	Level	Read	Limit	Over	APos	TPos	Remark	Pol/Phase	Note	MHz	dBuV/m	dBuV	dB/m	dBuV/m	dB	cm	deg			1	2387.50	53.39	16.06	37.33	74.00	-20.61	235	236 Peak	Vertical	2 *	2483.35	96.55	59.17	37.38	74.00	22.55	235	236 Peak	Vertical	3	2799.53	54.50	16.59	37.91	74.00	-19.50	235	236 Peak	Vertical
Freq	Level	Read	Limit	Over	APos	TPos	Remark	Pol/Phase	Note																																																																																												
MHz	dBuV/m	dBuV	dB/m	dBuV/m	dB	cm	deg																																																																																														
1	2339.33	52.48	15.31	37.17	74.00	-21.52	100	233 Peak	Horizontal																																																																																												
2 *	2483.35	93.45	56.07	37.38	74.00	19.45	100	233 Peak	Horizontal																																																																																												
3	2856.30	54.02	15.92	38.10	74.00	-19.98	100	233 Peak	Horizontal																																																																																												
Freq	Level	Read	Limit	Over	APos	TPos	Remark	Pol/Phase	Note																																																																																												
MHz	dBuV/m	dBuV	dB/m	dBuV/m	dB	cm	deg																																																																																														
1	2387.50	53.39	16.06	37.33	74.00	-20.61	235	236 Peak	Vertical																																																																																												
2 *	2483.35	96.55	59.17	37.38	74.00	22.55	235	236 Peak	Vertical																																																																																												
3	2799.53	54.50	16.59	37.91	74.00	-19.50	235	236 Peak	Vertical																																																																																												

ANT 1

Low Channel (Horizontal) Average

Low Channel (Vertical) Average



TUV Rheinland Taiwan Ltd.
No. 458-18, Sec 2, Fenliao, Linkou Dist., New Taipei City 244, Taiwan(R.O.C.)
Tel: +886-2172-1000 Fax: +886-2172-1322

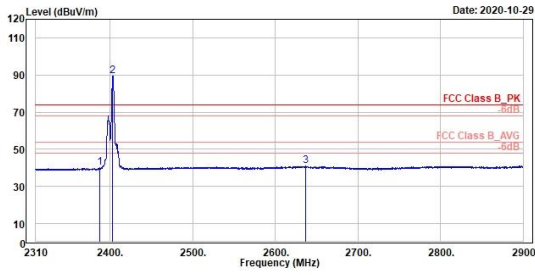

Freq	Level	Read	Limit	Over	APos	TPos	Remark	Pol/Phase	Note
MHz	dBuV/m	dBuV	dB/m	dBuV/m	dB	cm	deg		
1	2387.86	40.22	2.89	37.33	54.00	-13.78	180	233	Average Horizontal
2 *	2483.35	89.32	51.94	37.38	54.00	35.32	180	233	Average Horizontal
3	2636.51	41.01	3.13	37.88	54.00	-12.99	180	233	Average Horizontal



TUV Rheinland Taiwan Ltd.
No. 458-18, Sec 2, Fenliao, Linkou Dist., New Taipei City 244, Taiwan(R.O.C.)
Tel: +886-2172-1000 Fax: +886-2172-1322

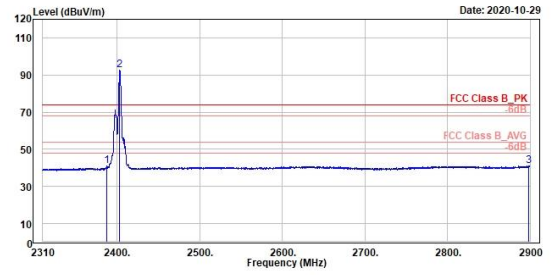

Freq	Level	Read	Limit	Over	APos	TPos	Remark	Pol/Phase	Note
MHz	dBuV/m	dBuV	dB/m	dBuV/m	dB	cm	deg		
1	2387.62	40.98	3.65	37.33	54.00	-13.02	235	236	Average Vertical
2 *	2483.35	92.48	55.82	37.38	54.00	38.48	235	236	Average Vertical
3	2898.47	40.95	2.64	38.31	54.00	-13.05	235	236	Average Vertical

ANT 1

High Channel (Horizontal) Peak

High Channel (Vertical) Peak



TUV Rheinland Taiwan Ltd.
No. 458-18, Sec 2, Fenliao, Linkou Dist., New Taipei City 244, Taiwan(R.O.C.)
Tel: +886-2172-1000 Fax: +886-2172-1322

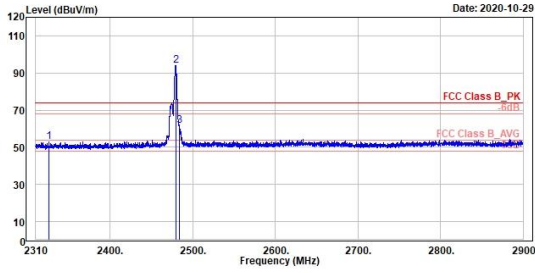

Peak	Freq	Level	Read Level	Factor	Limit Line	Over Limit	APos	TPos	Remark	Pol/Phase	Note
	MHz	dBuV/m	dBuV	dB/m	dBuV/m	dB	cm	deg			
1	2325.98	52.78	15.65	37.13	74.00	-21.22	180	47	Peak	Horizontal	
2 *	2479.35	93.89	56.33	37.56	74.00	19.89	180	47	Peak	Horizontal	
3	2483.58	61.81	24.25	37.56	74.00	-12.19	180	47	Peak	Horizontal	



TUV Rheinland Taiwan Ltd.
No. 458-18, Sec 2, Fenliao, Linkou Dist., New Taipei City 244, Taiwan(R.O.C.)
Tel: +886-2172-1000 Fax: +886-2172-1322

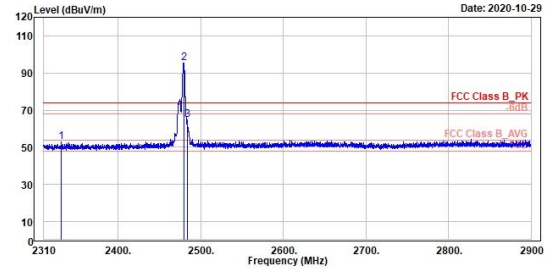

Peak	Freq	Level	Read Level	Factor	Limit Line	Over Limit	APos	TPos	Remark	Pol/Phase	Note
	MHz	dBuV/m	dBuV	dB/m	dBuV/m	dB	cm	deg			
1	2331.08	52.85	15.71	37.14	74.00	-21.15	288	357	Peak	Vertical	
2 *	2479.35	95.22	57.66	37.56	74.00	21.22	288	357	Peak	Vertical	
3	2483.58	64.82	27.26	37.56	74.00	-9.18	288	357	Peak	Vertical	

ANT 1
High Channel (Horizontal) Average
High Channel (Vertical) Average

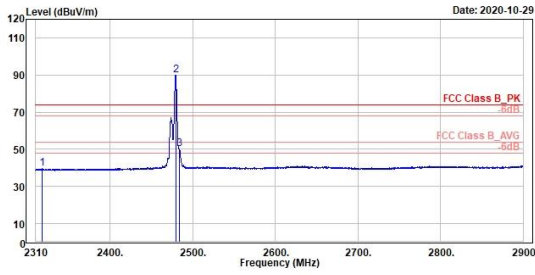

TUV Rheinland Taiwan Ltd.
 No. 458-18, Sec 2, Fenhiao, Linkou Dist., New Taipei City 244, Taiwan(R.O.C.)
 Tel: +886-2172-1000 Fax: +886-2172-1322



1	2	3
Level	Level	Level
Factor	Factor	Factor
Limit	Limit	Limit
Over	Over	Over
APos	APos	APos
TPos	TPos	TPos
Remark	Remark	Remark
Pol/Phase	Pol/Phase	Pol/Phase
Note	Note	Note
2317.42	2479.35	2483.50
39.50	89.68	50.16
2.40	52.12	12.60
37.10	37.56	37.56
54.00	54.00	54.00
-14.50	35.68	-3.84
100	100	100
47	47	47
Average	Average	Average
Horizontal	Horizontal	Horizontal

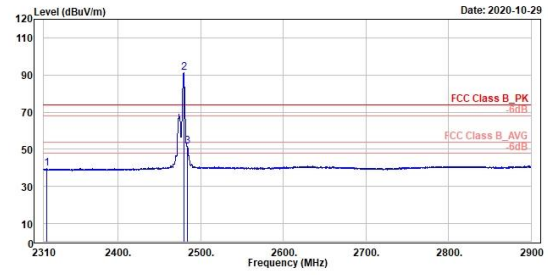

TUV Rheinland Taiwan Ltd.
 No. 458-18, Sec 2, Fenhiao, Linkou Dist., New Taipei City 244, Taiwan(R.O.C.)
 Tel: +886-2172-1000 Fax: +886-2172-1322



1	2	3
Level	Level	Level
Factor	Factor	Factor
Limit	Limit	Limit
Over	Over	Over
APos	APos	APos
TPos	TPos	TPos
Remark	Remark	Remark
Pol/Phase	Pol/Phase	Pol/Phase
Note	Note	Note
2313.77	2479.35	2483.50
39.54	81.03	51.47
2.45	53.47	13.91
37.09	37.56	37.56
54.00	54.00	54.00
-14.46	37.03	-2.53
288	288	288
357	357	357
Average	Average	Average
Vertical	Vertical	Vertical

ANT 2

Low Channel (Horizontal) Peak

Low Channel (Vertical) Peak

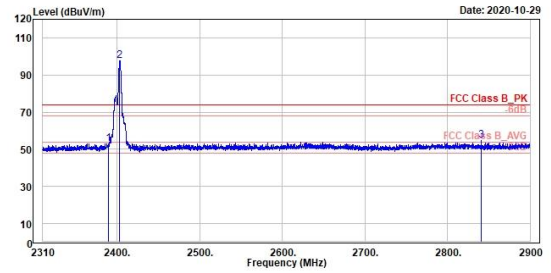
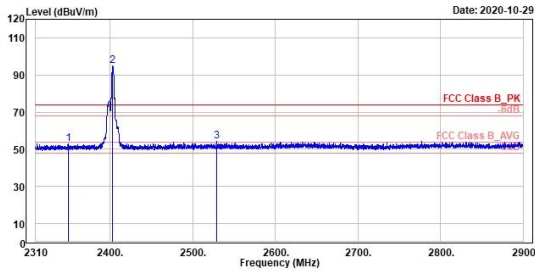

Peak #	Freq (MHz)	Level (dBuV/m)	Read Level (dBuV)	Factor (dB/m)	Limit Line (dBuV/m)	Over Limit (dB)	APos (cm)	TPos (deg)	Remark	Pol/Phase	Note
1	2349.11	52.91	15.71	37.20	74.00	-21.09	112	219	Peak	Horizontal	
2 *	2403.35	94.69	57.31	37.38	74.00	20.69	112	219	Peak	Horizontal	
3	2529.56	54.32	16.59	37.73	74.00	-19.68	112	219	Peak	Horizontal	

Peak #	Freq (MHz)	Level (dBuV/m)	Read Level (dBuV)	Factor (dB/m)	Limit Line (dBuV/m)	Over Limit (dB)	APos (cm)	TPos (deg)	Remark	Pol/Phase	Note
1	2389.06	52.97	15.64	37.33	74.00	-21.03	235	232	Peak	Vertical	
2 *	2403.35	97.73	60.35	37.38	74.00	23.73	235	232	Peak	Vertical	
3	2841.24	54.70	16.66	38.04	74.00	-19.30	235	232	Peak	Vertical	

ANT 2

Low Channel (Horizontal) Average

Low Channel (Vertical) Average



TUV Rheinland Taiwan Ltd.
No. 458-18, Sec 2, Fenliao, Linkou Dist., New Taipei City 244, Taiwan(R.O.C.)
Tel: +886-2172-1000 Fax: +886-2172-1322

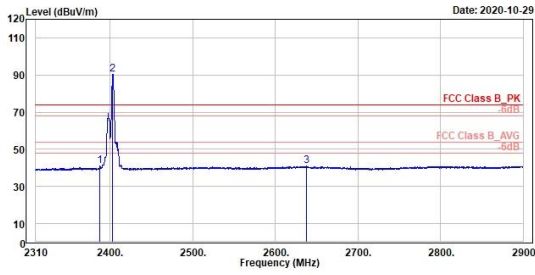

1	2	3
2387.62	2403.35	2637.80
40.90	90.51	40.89
3.57	53.13	3.01
37.33	37.38	37.88
54.00	54.00	54.00
-13.10	36.51	-13.11
112	112	112
219	219	219
Average	Average	Average
Horizontal	Horizontal	Horizontal



TUV Rheinland Taiwan Ltd.
No. 458-18, Sec 2, Fenliao, Linkou Dist., New Taipei City 244, Taiwan(R.O.C.)
Tel: +886-2172-1000 Fax: +886-2172-1322

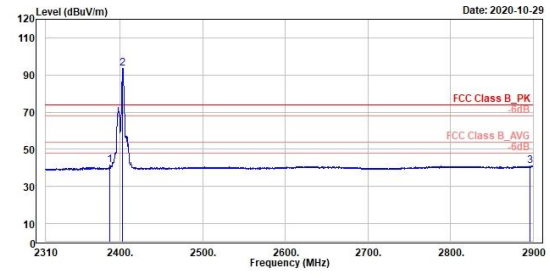

1	2	3
2387.76	2403.35	2896.11
41.44	93.58	40.90
4.11	56.20	2.60
37.33	37.38	38.30
54.00	54.00	54.00
-12.56	39.58	-13.10
235	235	235
232	232	232
Average	Average	Average
Vertical	Vertical	Vertical

ANT 2
High Channel (Horizontal) Peak
High Channel (Vertical) Peak

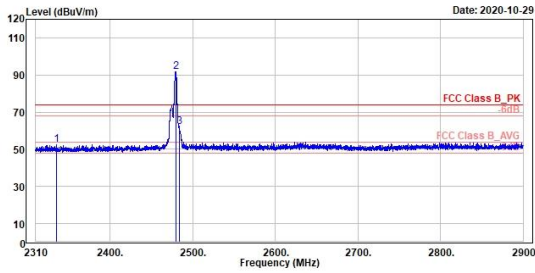

TÜV Rheinland Taiwan Ltd.
 No. 458-18, Sec 2, Fenliiao, Linkou Dist., New Taipei City 244, Taiwan(R.O.C.)
 Tel: +886-2172-1000 Fax: +886-2172-1322



Peak	Freq (MHz)	Level (dBuV/m)	Read Level (dBuV)	Factor (dB/m)	Limit Line (dBuV/m)	Over Limit (dB)	APos (cm)	TPos (deg)	Remark	Pol/Phase	Note
1	2334.78	52.61	15.45	37.16	74.00	-21.39	100	50	Peak	Horizontal	
2 *	2479.35	91.74	54.18	37.56	74.00	17.74	100	50	Peak	Horizontal	
3	2483.46	62.06	24.50	37.56	74.00	-11.94	100	50	Peak	Horizontal	

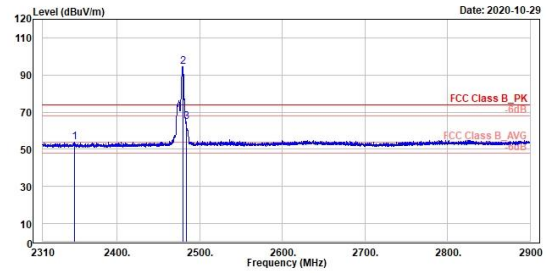

TÜV Rheinland Taiwan Ltd.
 No. 458-18, Sec 2, Fenliiao, Linkou Dist., New Taipei City 244, Taiwan(R.O.C.)
 Tel: +886-2172-1000 Fax: +886-2172-1322



Peak	Freq (MHz)	Level (dBuV/m)	Read Level (dBuV)	Factor (dB/m)	Limit Line (dBuV/m)	Over Limit (dB)	APos (cm)	TPos (deg)	Remark	Pol/Phase	Note
1	2348.16	54.03	16.83	37.20	74.00	-19.97	298	244	Peak	Vertical	
2 *	2479.35	94.54	56.98	37.56	74.00	20.54	298	244	Peak	Vertical	
3	2483.50	65.01	27.45	37.56	74.00	-8.99	298	244	Peak	Vertical	

ANT 2

High Channel (Horizontal) Average

High Channel (Vertical) Average



TUV Rheinland Taiwan Ltd.
No. 458-18, Sec 2, Fenliiao, Linkou Dist., New Taipei City 244, Taiwan(R.O.C.)
Tel: +886-2172-1000 Fax: +886-2172-1322

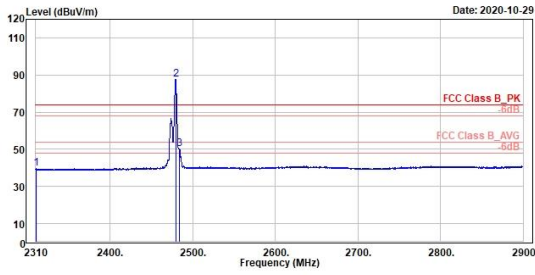

1	2	3	Read Level	Read Level Factor	Limit Line	Over Limit	APos	TPos	Remark	Pol/Phase	Note
MHz	dBuV/m	dBuV	dB/m	dBuV/m	dB	cm	deg				
2310.59	39.55	2.47	37.08	54.00	-14.45	100	50	Average	Horizontal		
2479.35	87.58	50.82	37.56	54.00	33.58	100	50	Average	Horizontal		
2483.50	50.35	12.79	37.56	54.00	-3.65	100	50	Average	Horizontal		



TUV Rheinland Taiwan Ltd.
No. 458-18, Sec 2, Fenliiao, Linkou Dist., New Taipei City 244, Taiwan(R.O.C.)
Tel: +886-2172-1000 Fax: +886-2172-1322

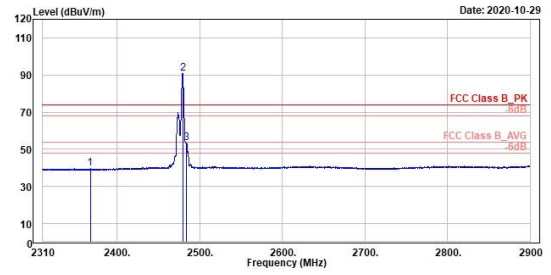

1	2	3	Read Level	Read Level Factor	Limit Line	Over Limit	APos	TPos	Remark	Pol/Phase	Note
MHz	dBuV/m	dBuV	dB/m	dBuV/m	dB	cm	deg				
2367.40	39.51	2.25	37.26	54.00	-14.49	298	244	Average	Vertical		
2479.35	90.95	53.29	37.56	54.00	36.95	298	244	Average	Vertical		
2483.50	53.58	16.82	37.56	54.00	-0.42	298	244	Average	Vertical		

Spurious Emissions, Tx Mode, 9kHz ~ 30MHz

ANT 2

High Channel (Open) 9kHz~150kHz

High Channel (Open) 150kHz~30MHz



TUV Rheinland Taiwan Ltd.
No. 458-18, Sec 2, Fenliao, Linkou Dist., New Taipei City 244, Taiwan(R.O.C.)
Tel: +886-2172-1000 Fax: +886-2172-1322

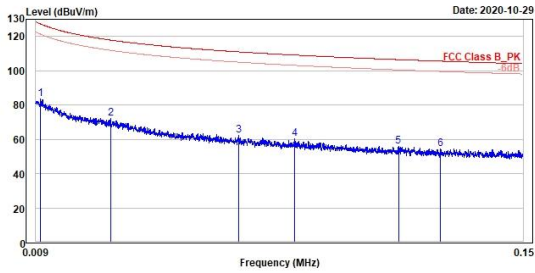

Freq	Level	Read	Limit	Over	APos	TPos	Remark	Pol/Phase	Note
MHz	dBuV/m	dBuV	dB/m	dBuV/m	dB	cm	deg		
1	83.38	4.72	78.58	127.24	-43.94	100	330	QP	Open
2	72.28	1.74	70.54	117.86	-45.58	100	156	QP	Open
3	62.15	-0.50	62.65	110.99	-48.84	100	230	QP	Open
4	60.27	-0.67	60.94	109.12	-48.85	100	75	QP	Open
5	55.69	-2.75	58.44	106.46	-50.77	100	73	QP	Open
6	54.19	-3.54	57.73	105.58	-51.39	100	33	QP	Open



TUV Rheinland Taiwan Ltd.
No. 458-18, Sec 2, Fenliao, Linkou Dist., New Taipei City 244, Taiwan(R.O.C.)
Tel: +886-2172-1000 Fax: +886-2172-1322

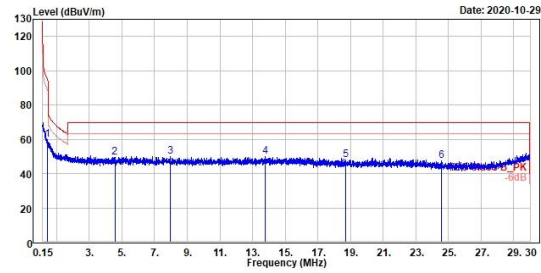

Freq	Level	Read	Limit	Over	APos	TPos	Remark	Pol/Phase	Note
MHz	dBuV/m	dBuV	dB/m	dBuV/m	dB	cm	deg		
1	83.38	4.72	78.58	127.24	-43.94	100	330	QP	Open
2	72.28	1.74	70.54	117.86	-45.58	100	156	QP	Open
3	62.15	-0.50	62.65	110.99	-48.84	100	230	QP	Open
4	60.27	-0.67	60.94	109.12	-48.85	100	75	QP	Open
5	55.69	-2.75	58.44	106.46	-50.77	100	73	QP	Open
6	54.19	-3.54	57.73	105.58	-51.39	100	33	QP	Open

ANT 2

High Channel (Close) 9kHz~150kHz

High Channel (Close) 150kHz~30MHz



TUV Rheinland Taiwan Ltd.
No. 458-18, Sec 2, Fenliao, Linkou Dist., New Taipei City 244, Taiwan(R.O.C.)
Tel: +886-2172-1000 Fax: +886-2172-1322

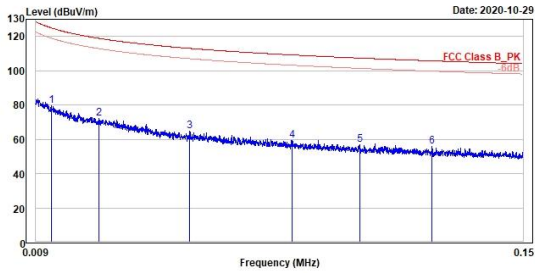

Freq	Level	Read	Limit	Over	APos	TPos	Remark	Pol/Phase	Note
MHz	dBuV/m	dBuV	dB/m	dBuV/m	dB	cm	deg		
1	0.01	79.41	2.76	76.65	124.99	-45.58	100	143 QP	Close
2	0.03	71.96	0.73	71.23	118.87	-46.91	100	42 QP	Close
3	0.05	64.51	-0.03	64.54	113.01	-48.50	100	1 QP	Close
4	0.08	59.38	-1.62	61.00	109.21	-49.83	100	58 QP	Close
5	0.10	56.99	-2.10	59.09	107.35	-50.36	100	143 QP	Close
6	0.12	55.72	-2.16	57.88	105.75	-50.03	100	37 QP	Close



TUV Rheinland Taiwan Ltd.
No. 458-18, Sec 2, Fenliao, Linkou Dist., New Taipei City 244, Taiwan(R.O.C.)
Tel: +886-2172-1000 Fax: +886-2172-1322

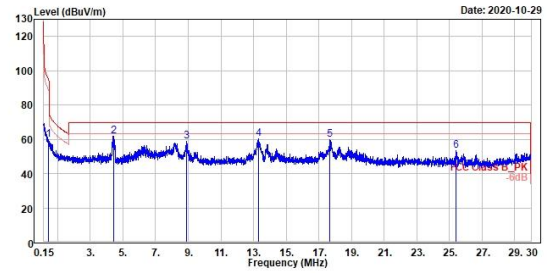

Freq	Level	Read	Limit	Over	APos	TPos	Remark	Pol/Phase	Note
MHz	dBuV/m	dBuV	dB/m	dBuV/m	dB	cm	deg		
1	0.43	59.73	11.85	47.88	94.92	-35.19	100	257 QP	Close
2	4.41	62.00	23.67	38.33	69.50	-7.50	100	360 QP	Close
3	8.92	58.64	20.84	37.80	69.50	-10.86	100	42 QP	Close
4	13.31	60.22	22.75	37.47	69.50	-9.28	100	16 QP	Close
5	17.69	59.71	22.78	36.93	69.50	-9.79	100	94 QP	Close
6	25.42	53.28	19.16	34.12	69.50	-16.22	100	170 QP	Close

Spurious Emissions, Tx Mode, 30MHz ~ 1GHz
ANT 2
High Channel (Horizontal)
High Channel (Vertical)

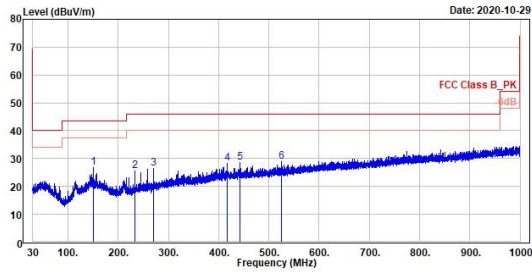

TÜV Rheinland Taiwan Ltd.
 No. 458-18, Sec. 2, Fenliao, Linkou Dist., New Taipei City 244, Taiwan(R.O.C.)
 Tel: +886-2172-1000 Fax: +886-2172-1322



Freq	Level	Read	Limit	Over	APos	TPos	Remark	Pol/Phase	Note
MHz	dBuV/m	dBuV	dB/m	dBuV/m	dB	cm	deg		
1	150.96	26.00	34.48	-7.68	43.50	-16.70	200	112 QP	Horizontal
2	233.51	25.62	34.25	-8.63	46.00	-20.38	100	299 QP	Horizontal
3	270.37	26.44	33.85	-7.41	46.00	-19.56	100	276 QP	Horizontal
4	416.55	28.26	32.61	-4.35	46.00	-17.74	100	262 QP	Horizontal
5	442.44	28.64	32.51	-3.87	46.00	-17.36	100	159 QP	Horizontal
6	525.67	28.82	31.55	-2.73	46.00	-17.18	200	292 QP	Horizontal

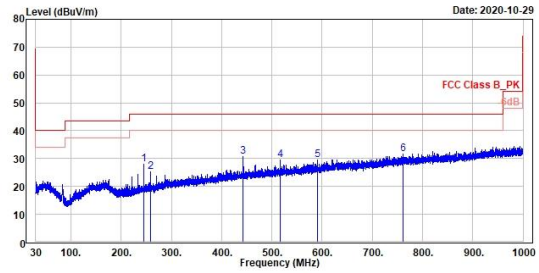

TÜV Rheinland Taiwan Ltd.
 No. 458-18, Sec. 2, Fenliao, Linkou Dist., New Taipei City 244, Taiwan(R.O.C.)
 Tel: +886-2172-1000 Fax: +886-2172-1322



Freq	Level	Read	Limit	Over	APos	TPos	Remark	Pol/Phase	Note
MHz	dBuV/m	dBuV	dB/m	dBuV/m	dB	cm	deg		
1	245.83	27.84	35.98	-8.14	46.00	-18.16	200	232 QP	Vertical
2	258.05	25.30	33.19	-7.89	46.00	-20.70	200	0 QP	Vertical
3	442.44	30.81	34.68	-3.87	46.00	-15.19	100	260 QP	Vertical
4	516.07	29.48	32.34	-2.86	46.00	-16.52	100	279 QP	Vertical
5	591.15	29.41	31.00	-1.59	46.00	-16.59	200	72 QP	Vertical
6	761.48	31.52	30.20	1.32	46.00	-14.48	400	121 QP	Vertical

Spurious Emissions, Tx Mode, 1GHz ~ 26.5GHz

ANT 1

Low Channel (Horizontal)

Low Channel (Vertical)



TUV Rheinland Taiwan Ltd.
No. 458-18, Sec 2, Fenliao, Linkou Dist., New Taipei City 244, Taiwan(R.O.C.)
Tel: +886-2172-1000 Fax: +886-2172-1322

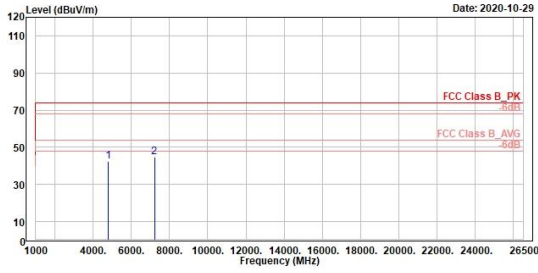

Freq	Level	Read Level	Factor	Limit Line	Over Limit	APos	TPos	Remark	Pol/Phase	Note
MHz	dBuV/m	dBuV	dB/m	dBuV/m	dB	cm	deg			
1	4896.70	42.36	52.55	-10.19	74.00	-31.64	180	279 Peak	Horizontal	
2	7210.05	44.53	52.21	-7.68	74.00	-29.47	180	227 Peak	Horizontal	



TUV Rheinland Taiwan Ltd.
No. 458-18, Sec 2, Fenliao, Linkou Dist., New Taipei City 244, Taiwan(R.O.C.)
Tel: +886-2172-1000 Fax: +886-2172-1322

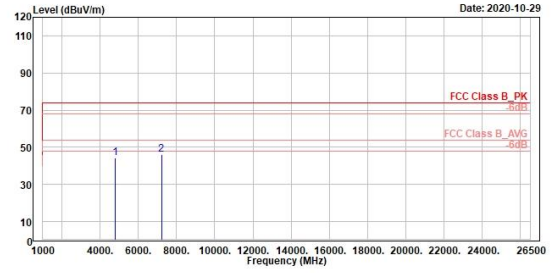

Freq	Level	Read Level	Factor	Limit Line	Over Limit	APos	TPos	Remark	Pol/Phase	Note
MHz	dBuV/m	dBuV	dB/m	dBuV/m	dB	cm	deg			
1	4896.70	44.42	54.61	-10.19	74.00	-29.58	180	213 Peak	Vertical	
2	7210.05	45.93	53.61	-7.68	74.00	-28.07	280	231 Peak	Vertical	

ANT 1

Middle Channel (Horizontal)

Middle Channel (Vertical)



TÜV Rheinland Taiwan Ltd.
No. 458-18, Sec. 2, Fenliao, Linkou Dist., New Taipei City 244, Taiwan(R.O.C.)
Tel: +886-2172-1000 Fax: +886-2172-1322

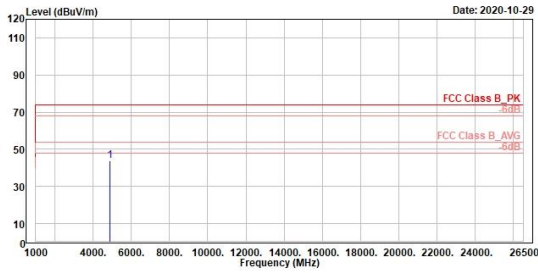

1	4882.70	43.75	53.81	-10.06	74.00	-30.25	100	242	Peak	Horizontal
---	---------	-------	-------	--------	-------	--------	-----	-----	------	------------



TÜV Rheinland Taiwan Ltd.
No. 458-18, Sec. 2, Fenliao, Linkou Dist., New Taipei City 244, Taiwan(R.O.C.)
Tel: +886-2172-1000 Fax: +886-2172-1322

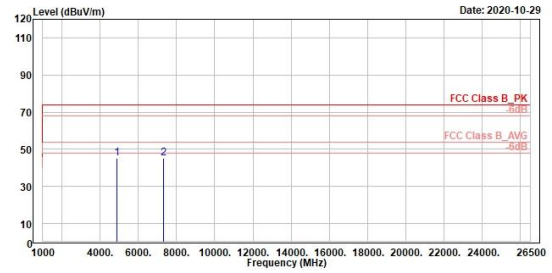

1	4882.70	45.19	55.25	-10.06	74.00	-28.81	100	238	Peak	Vertical
2	7324.05	45.37	53.16	-7.79	74.00	-28.63	100	265 <td>Peak</td> <td>Vertical</td>	Peak	Vertical

ANT 1

High Channel (Horizontal)

High Channel (Vertical)



TÜV Rheinland Taiwan Ltd.
No. 458-18, Sec. 2, Fenliao, Linkou Dist., New Taipei City 244, Taiwan(R.O.C.)
Tel: +886-2172-1000 Fax: +886-2172-1322

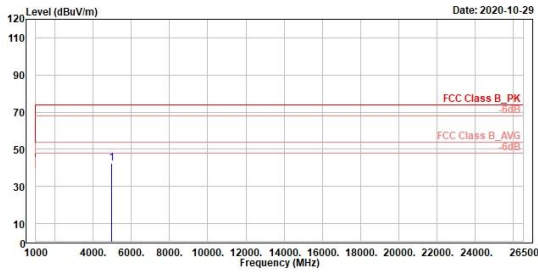

Freq	Level	Read Level	Factor	Limit Line	Over Limit	APos	TPos	Remark	Pol/Phase	Note
MHz	dBuV/m	dBuV	dB/m	dBuV/m	dB	cm	deg			
1	4958.70	42.59	52.34	-9.75	74.00	-31.41	100	249 Peak	Horizontal	



TÜV Rheinland Taiwan Ltd.
No. 458-18, Sec. 2, Fenliao, Linkou Dist., New Taipei City 244, Taiwan(R.O.C.)
Tel: +886-2172-1000 Fax: +886-2172-1322

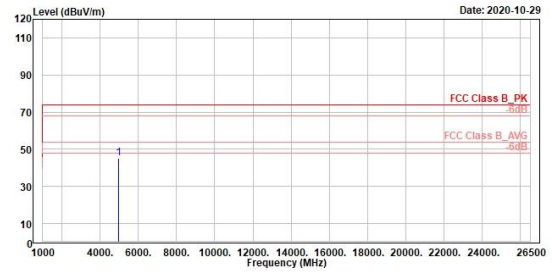

Freq	Level	Read Level	Factor	Limit Line	Over Limit	APos	TPos	Remark	Pol/Phase	Note
MHz	dBuV/m	dBuV	dB/m	dBuV/m	dB	cm	deg			
1	4958.70	45.38	55.13	-9.75	74.00	-28.62	100	279 Peak	Vertical	

ANT 2

Low Channel (Horizontal)

Low Channel (Vertical)



TUV Rheinland Taiwan Ltd.
No. 458-18, Sec 2, Fenliao, Linkou Dist., New Taipei City 244, Taiwan(R.O.C.)
Tel: +886-2172-1000 Fax: +886-2172-1322

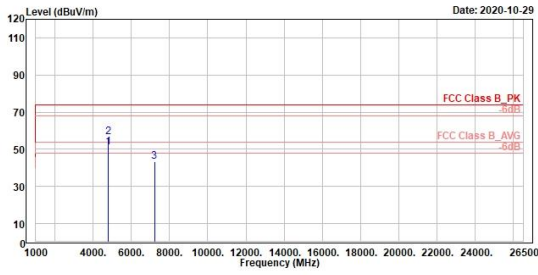

1	2	3
Level	Level	Level
Factor	Factor	Factor
Limit	Limit	Limit
Line	Line	Line
Limit	Limit	Limit
Over	Over	Over
Limit	Limit	Limit
Apos	Apos	Apos
TPos	TPos	TPos
Remark	Remark	Remark
Pol/Phase	Pol/Phase	Pol/Phase
Note	Note	Note
4896.70	4896.70	7218.05
50.95	56.61	43.35
61.14	66.80	51.03
-10.19	-10.19	-7.68
54.00	74.00	74.00
-3.05	-17.39	-30.65
299	299	200
207	207	209
Average	Peak	Peak
Horizontal	Horizontal	Horizontal



TUV Rheinland Taiwan Ltd.
No. 458-18, Sec 2, Fenliao, Linkou Dist., New Taipei City 244, Taiwan(R.O.C.)
Tel: +886-2172-1000 Fax: +886-2172-1322

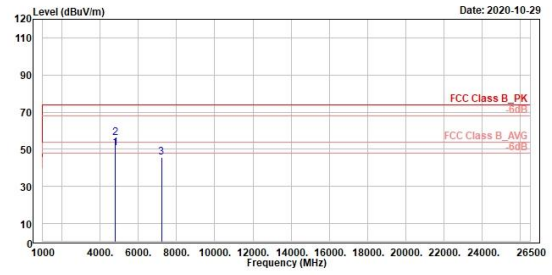

1	2	3
Level	Level	Level
Factor	Factor	Factor
Limit	Limit	Limit
Line	Line	Line
Limit	Limit	Limit
Over	Over	Over
Limit	Limit	Limit
Apos	Apos	Apos
TPos	TPos	TPos
Remark	Remark	Remark
Pol/Phase	Pol/Phase	Pol/Phase
Note	Note	Note
4896.70	4896.70	7218.05
50.60	56.21	45.81
60.79	66.40	53.49
-10.19	-10.19	-7.68
54.00	74.00	74.00
-3.40	-17.79	-28.19
100	100	300
311	311	308
Average	Peak	Peak
Vertical	Vertical	Vertical

ANT 2

Middle Channel (Horizontal)

Middle Channel (Vertical)



TUV Rheinland Taiwan Ltd.
No. 458-18, Sec. 2, Fenliao, Linkou Dist., New Taipei City 244, Taiwan(R.O.C.)
Tel: +886-2172-1000 Fax: +886-2172-1322

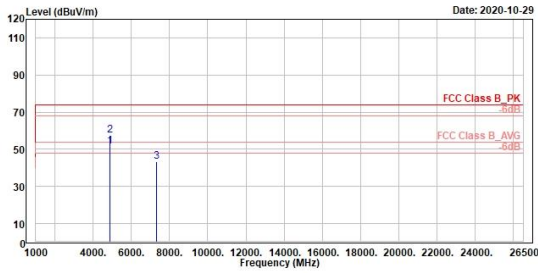

1	2	3							
Freq	Level	Read	Limit	Over	APos	TPos	Remark	Pol/Phase	Note
MHz	dBuV/m	dBuV	dB/m	dBuV/m	dB	cm	deg		
4882.70	51.61	61.67	-10.06	54.00	-2.39	260	213 Average	Horizontal	
4882.70	57.27	67.33	-10.06	74.00	-16.73	260	213 Peak	Horizontal	
7324.05	43.54	51.33	-7.79	74.00	-30.46	200	196 Peak	Horizontal	



TUV Rheinland Taiwan Ltd.
No. 458-18, Sec. 2, Fenliao, Linkou Dist., New Taipei City 244, Taiwan(R.O.C.)
Tel: +886-2172-1000 Fax: +886-2172-1322

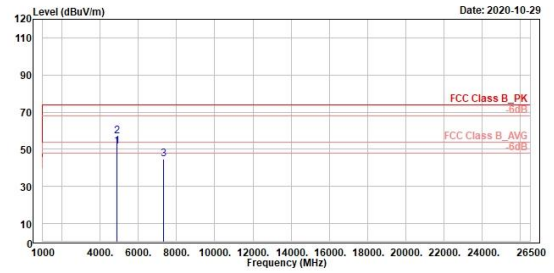

1	2	3							
Freq	Level	Read	Limit	Over	APos	TPos	Remark	Pol/Phase	Note
MHz	dBuV/m	dBuV	dB/m	dBuV/m	dB	cm	deg		
4882.70	51.46	61.52	-10.06	54.00	-2.54	100	299 Average	Vertical	
4882.70	57.15	67.21	-10.06	74.00	-16.85	100	299 Peak	Vertical	
7324.05	44.84	52.63	-7.79	74.00	-29.16	300	335 Peak	Vertical	

ANT 2

High Channel (Horizontal)

High Channel (Vertical)



TUV Rheinland Taiwan Ltd.
No. 458-18, Sec. 2, Fenliao, Linkou Dist., New Taipei City 244, Taiwan(R.O.C.)
Tel: +886-2172-1000 Fax: +886-2172-1322

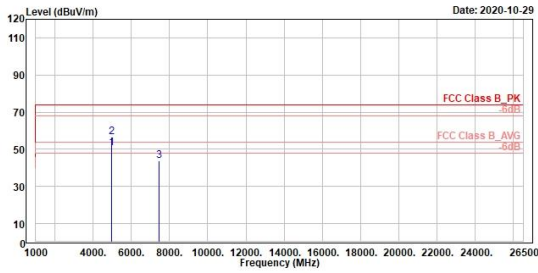

1	2	3	4	5	6	7	8	9	10	11	12	13	14	15	16	17	18	19	20
1	Level	Read	Level	Factor	Limit	Over	Apos	TPos	Remark	Pol/Phase	Note								
1	MHz	dBuV/m	dBuV	dB/m	dBuV/m	dB	cm	deg											
1	4958.70	50.53	60.20	-9.75	54.00	-3.47	242	210	Average	Horizontal									
2	4958.70	56.67	66.42	-9.75	74.00	-17.33	242	210	Peak	Horizontal									
3	7438.05	43.66	51.38	-7.72	74.00	-30.34	200	202	Peak	Horizontal									



TUV Rheinland Taiwan Ltd.
No. 458-18, Sec. 2, Fenliao, Linkou Dist., New Taipei City 244, Taiwan(R.O.C.)
Tel: +886-2172-1000 Fax: +886-2172-1322

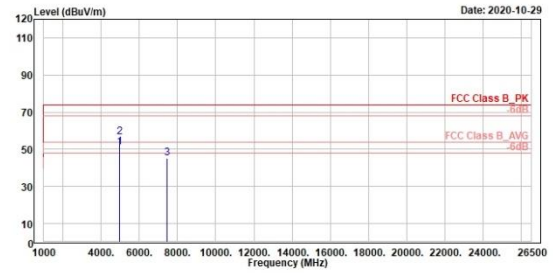

1	2	3	4	5	6	7	8	9	10	11	12	13	14	15	16	17	18	19	20
1	Level	Read	Level	Factor	Limit	Over	Apos	TPos	Remark	Pol/Phase	Note								
1	MHz	dBuV/m	dBuV	dB/m	dBuV/m	dB	cm	deg											
1	4958.70	51.13	60.88	-9.75	54.00	-2.87	100	318	Average	Vertical									
2	4958.70	56.68	66.43	-9.75	74.00	-17.32	100	318	Peak	Vertical									
3	7438.05	45.02	52.74	-7.72	74.00	-28.98	300	330	Peak	Vertical									

Mains Conducted Emission, 150kHz ~ 30MHz

Worst Band

(Line)

(Neutral)



TUV Rheinland Taiwan Ltd(New Taipei City Branch),
No. 458-19, Sec. 2, Fenliao Rd., Linkou Dist., New Taipei City 244
Tel:+886-2172-1000 Fax:+886-2172-1322

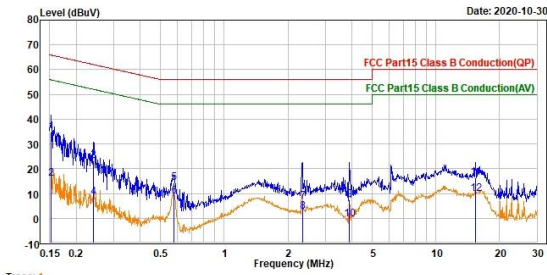

Trace: 1

	Read	Factor	Limit	Over	Remark	Pol/Phase	Note
Freq	Level		Line	Limit			
MHz	dBuV	dB	dBuV	dBuV	dB		
1	0.152	34.90	0.05	34.95	65.88 -30.93	QP	line1
2	0.152	15.97	0.05	16.02	55.88 -39.86	Average	line1
3	0.241	23.24	0.05	23.29	62.07 -38.78	QP	line1
4	0.241	8.41	0.05	8.46	52.07 -43.61	Average	line1
5	0.576	14.20	0.06	14.26	56.00 -41.74	QP	line1
6	0.576	8.61	0.06	8.67	46.00 -37.13	Average	line1
7	2.338	6.77	0.12	6.89	56.00 -49.11	QP	line1
8	2.338	2.53	0.12	2.65	46.00 -43.35	Average	line1
9	3.887	7.43	0.15	7.58	56.00 -48.42	QP	line1
10	3.887	-0.74	0.15	-0.59	46.00 -46.59	Average	line1
11	15.384	15.85	0.42	16.27	60.00 -43.73	QP	line1
12	15.384	9.52	0.42	9.94	50.00 -40.06	Average	line1



TUV Rheinland Taiwan Ltd(New Taipei City Branch),
No. 458-19, Sec. 2, Fenliao Rd., Linkou Dist., New Taipei City 244
Tel:+886-2172-1000 Fax:+886-2172-1322

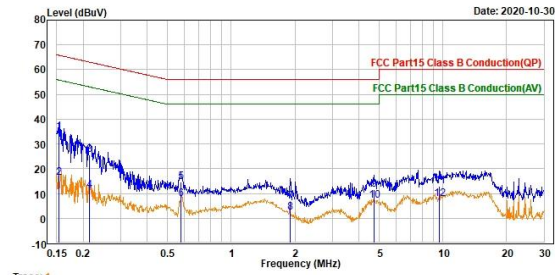

Trace: 1

	Read	Factor	Limit	Over	Remark	Pol/Phase	Note
Freq	Level		Line	Limit			
MHz	dBuV	dB	dBuV	dBuV	dB		
1	0.153	34.85	0.05	34.90	65.83 -30.93	QP	neutral
2	0.153	16.32	0.05	16.37	55.83 -39.46	Average	neutral
3	0.215	25.42	0.05	25.47	63.02 -37.55	QP	neutral
4	0.215	11.17	0.05	11.22	53.02 -41.80	Average	neutral
5	0.576	14.45	0.06	14.51	56.00 -41.49	QP	neutral
6	0.576	7.69	0.06	7.75	46.00 -38.25	Average	neutral
7	1.896	6.58	0.10	6.68	56.00 -49.32	QP	neutral
8	1.896	2.06	0.10	2.16	46.00 -43.84	Average	neutral
9	4.721	11.48	0.17	11.65	56.00 -44.35	QP	neutral
10	4.721	6.85	0.17	7.02	46.00 -38.98	Average	neutral
11	9.629	12.56	0.29	12.85	60.00 -47.15	QP	neutral
12	9.629	7.55	0.29	7.84	50.00 -42.16	Average	neutral