

Prüfbericht-Nr.: <i>Test report no.:</i>	CN20WS3V (P15C-BT) 001	Auftrags-Nr.: <i>Order no.:</i>	238491635	Seite 1 von 30 Page 1 of 30
Kunden-Referenz-Nr.: <i>Client reference no.:</i>	N/A	Auftragsdatum: <i>Order date:</i>	2020-09-14	
Auftraggeber: <i>Client:</i>	Audeze LLC. 3410 S Susan st, Santa Ana, CA 92704, USA			
Prüfgegenstand: <i>Test item:</i>	Penrose Wireless Stereo Headset			
Bezeichnung / Typ-Nr.: <i>Identification / Type no.:</i>	Penrose P RX, Penrose X RX			
Auftrags-Inhalt: <i>Order content:</i>	FCC Part 15C Test report (BT)			
Prüfgrundlage: <i>Test specification:</i>	FCC 47CFR Part 15: Subpart C Section 15.247			
Wareneingangsdatum: <i>Date of sample receipt:</i>	2020-10-05			
Prüfmuster-Nr.: <i>Test sample no.:</i>	A002923011-047 A002923011-030			
Prüfzeitraum: <i>Testing period:</i>	2020-10-19 - 2020-10-29			
Ort der Prüfung: <i>Place of testing:</i>	EMC/RF Laboratory Taipei			
Prüflaboratorium: <i>Testing laboratory:</i>	Taipei Testing Laboratories			
Prüfergebnis*: <i>Test result*:</i>	Pass			
überprüft von: <i>reviewed by:</i>	genehmigt von: <i>authorized by:</i>			
Datum: <i>Date:</i> 2020-11-06	 Jack Chang		Ausstellungsdatum: <i>Issue date:</i> 2020-11-06	
Stellung / Position:	Senior Project Manager		Brenda Chen Senior Project Manager	
Sonstiges / Other:	The RF characteristics and PCB layout are the same, the only differences is color between two models.			
Zustand des Prüfgegenstandes bei Anlieferung: <i>Condition of the test item at delivery:</i>	Prüfmuster vollständig und unbeschädigt <i>Test item complete and undamaged</i>			
* Legende:	1 = sehr gut P(ass) = entspricht o.g. Prüfgrundlage(n)	2 = gut F(ail) = entspricht nicht o.g. Prüfgrundlage(n)	3 = befriedigend N/A = nicht anwendbar	4 = ausreichend N/T = nicht getestet
* Legend:	1 = very good P(ass) = passed a.m. test specification(s)	2 = good F(ail) = failed a.m. test specification(s)	3 = satisfactory N/A = not applicable	4 = sufficient N/T = not tested
Dieser Prüfbericht bezieht sich nur auf das o.g. Prüfmuster und darf ohne Genehmigung der Prüfstelle nicht auszugsweise vervielfältigt werden. Dieser Bericht berechtigt nicht zur Verwendung eines Prüfzeichens. <i>This test report only relates to the a. m. test sample. Without permission of the test center this test report is not permitted to be duplicated in extracts. This test report does not entitle to carry any test mark.</i>				

TEST SUMMARY

Report Section	FCC Clause	Test Item	Result
5.1.1	15.247(b) & 15.203	Antenna Requirement	Pass
5.1.2	15.247(b)(1)	Peak Output Power	Pass
5.1.3	15.247(a)(1)	20 dB Bandwidth	Pass
5.1.3	2.1049	99% Occupied Bandwidth	Pass
5.1.4	15.247(d)	Conducted Spurious Emission and Band Edges	Pass
5.1.5	15.247(d) & 15.205 & 15.209	Radiated Spurious Emissions and Band Edges	Pass
5.1.6	15.247(a)(1)	Hopping Channel Separation	Pass
5.1.7	15.247(a)(1) (iii)	Number of Hopping Frequency Used	Pass
5.1.8	15.247(a)(1) (iii)	Dwell Time on Each Channel	Pass
5.2.1	15.207	Mains Conducted Emission	Pass
6.1	FCC KDB 447498 D01 v06	RF Exposure Compliance	Pass

Note:

1. If the Frequency Hopping Systems operating in 2400-2483.5 MHz band and the output power less than 125 mW. The hopping channel carrier frequencies separated by a minimum of 25 kHz or two-thirds of the 20 dB bandwidth of hopping channel whichever is greater.
2. Determining compliance based on the results of the compliance measurement, not taking into account measurement instrumentation uncertainty.

Contents

HISTORY OF THIS TEST REPORT	5
1. GENERAL REMARKS	6
1.1 COMPLEMENTARY MATERIALS.....	6
1.2 DECISION RULE OF CONFORMITY	6
2. TEST SITES	7
2.1 TEST LABORATORY	7
2.2 TEST FACILITY.....	7
2.3 TRACEABILITY	8
2.4 CALIBRATION	8
2.5 MEASUREMENT UNCERTAINTY	8
3. GENERAL PRODUCT INFORMATION.....	9
3.1 PRODUCT FUNCTION AND INTENDED USE	9
3.2 SYSTEM DETAILS AND RATINGS.....	9
3.3 NOISE GENERATING AND NOISE SUPPRESSING PARTS	10
3.4 SUBMITTED DOCUMENTS.....	10
4. TEST SET-UP AND OPERATION MODES.....	11
4.1 PRINCIPLE OF CONFIGURATION SELECTION	11
4.2 CARRIER FREQUENCY AND CHANNEL.....	11
4.3 TEST OPERATION AND TEST SOFTWARE.....	12
4.4 SPECIAL ACCESSORIES AND AUXILIARY EQUIPMENT	13
4.5 TEST SETUP DIAGRAM	14
5. TEST RESULTS	15
5.1 TRANSMITTER REQUIREMENT & TEST SUITES	15
5.1.1 <i>Antenna Requirement</i>	<i>15</i>
5.1.2 <i>Peak Output Power</i>	<i>16</i>
5.1.3 <i>20 dB Bandwidth and 99% Occupied Bandwidth.....</i>	<i>18</i>
5.1.4 <i>Conducted Spurious Emissions and Frequency Band Edges Measured in 100kHz Bandwidth.....</i>	<i>19</i>
5.1.5 <i>Radiated Spurious Emissions and Band Edges</i>	<i>20</i>
5.1.6 <i>Hopping Channel Separation.....</i>	<i>25</i>
5.1.7 <i>Number of Hopping Frequency.....</i>	<i>26</i>
5.1.8 <i>Dwell Time.....</i>	<i>27</i>
5.2 MAINS EMISSION	28
5.2.1 <i>Mains Conducted Emission.....</i>	<i>28</i>

6.	SAFETY HUMAN EXPOSURE	30
6.1	RF EXPOSURE COMPLIANCE	30
6.1.1	SAR Test Exclusion Thresholds.....	30

APPENDIX A - TEST RESULT OF CONDUCTED

**APPENDIX B - TEST RESULT OF RADIATED SPURIOUS EMISSIONS & MAINS CONDUCTED
EMISSION**

APPENDIX SP - PHOTOGRAPHS TEST SETUP

APPENDIX EP - PHOTOGRAPHS OF EUT

HISTORY OF THIS TEST REPORT

Report No.	Description	Date Issued
CN20WS3V (P15C-BT) 001	Original Release	2020-11-06

1. General Remarks

1.1 Complementary Materials

All attachments are integral parts of this test report. This applies especially to the following appendix:

Appendix A - Test Result of Conducted

Appendix B - Test Result of Radiated Spurious Emissions & Mains Conducted Emission

Appendix SP - Photographs Test Setup

Appendix EP - Photographs of EUT

Applied Standard and Test Levels

Radio
FCC 47CFR Part 15: Subpart C Section 15.247
FCC 47CFR Part 2: Subpart J Section 2.1049
ANSI C63.10:2013
KDB 558074 D01 15.247 Meas Guidance v05r02
KDB 447498 D01 General RF Exposure Guidance v06

1.2 Decision Rule of Conformity

The decision rule of conformity of this test report is following the requirements of the requested standard in the quotation, and agreed among testing laboratory and manufacturer (applicant) to exclude the consideration of Measurement Uncertainty, unless it is required by the specific standard.

2. Test Sites

2.1 Test Laboratory

Taipei Testing Laboratories

11F. No.758, Sec. 4, Bade Rd., Songshan Dist.
Taipei City 105
Taiwan (R.O.C.)

2.2 Test Facility

Taipei Testing Laboratories

No.458-18, Sec. 2, Fenliao Rd., Linkou Dist.,
New Taipei City 244
Taiwan (R.O.C.)
FCC Registration No.: 226631
ISED Registration No.: 25563

2.3 Traceability

All measurement equipment calibrations are traceable to NML(Taiwan)/NIST(USA) or where calibration is performed outside Taiwan, to equivalent nationally recognized standards organizations.

2.4 Calibration

Equipment requiring calibration is calibrated periodically in a suitably accredited Calibration Lab. Additionally all equipment is verified for proper performance on a regular basis using in house standards or comparisons.

2.5 Measurement Uncertainty

All measurement uncertainty values are shown with a coverage factor of $k=2$ to indicate a 95% level of confidence.

Emission Measurement Uncertainty

Parameter	Uncertainty
Radiated Emission (9 kHz ~ 30 MHz)	± 1.15 dB
Radiated Emission (30 MHz ~ 200 MHz)	± 1.30 dB
Radiated Emission (200 MHz ~ 1 GHz)	± 1.30 dB
Radiated Emission (1 GHz ~ 18 GHz)	± 1.54 dB
Radiated Emission (18 GHz ~ 40 GHz)	± 2.52 dB
Mains Conducted Emission	± 1.65 dB

3. General Product Information

3.1 Product Function and Intended Use

The EUT is a Penrose Wireless Stereo Headset. It contains a Bluetooth and 2.4GHz compatible module enabling the user to communicate data through a Wireless interface.

For details refer to the User Guide, Data Sheet and Circuit Diagram.

3.2 System Details and Ratings

Basic Information of EUT

Item	EUT information
Kind of Equipment/Test Item	Penrose Wireless Stereo Headset
Type Identification	Penrose P RX, Penrose X RX
FCC ID	2APRZ-PENROSERX

Technical Specification of EUT

Item	EUT information
Operating Frequency	2402 MHz ~ 2480 MHz
Channel Spacing	1 MHz
Channel number	79
Operation Voltage	5 Vdc (USB) 3.7 Vdc (Battery)
Modulation	GFSK, $\pi/4$ -DQPSK, 8DPSK
Maximum Output Power (mW)	3.08
Antenna Information	Refer to 5.1.1
Accessory Device	Refer to 4.4

3.3 Noise Generating and Noise Suppressing Parts

Refer to the Circuit Diagram.

3.4 Submitted Documents

- Circuit Diagram
- Instruction Manual
- Rating Label
- Technical Description

4. Test Set-up and Operation Modes

4.1 Principle of Configuration Selection

The test modes were adapted accordingly in reference to the instructions for use.

During testing, Channel and Power Controlling Software provided by the customer was used to control the operating channel as well as the output power level. The RF output power selection is for the setting of RF output expected by the customer and is going to be fixed on the firmware of the final end product. Bluetooth function and 2.4GHz function will not transmitter at same time.

Table for Parameters of Test Software Setting

Frequency (MHz)	Power Setting		
	GFSK	$\pi/4$ -DQPSK	8DPSK
2402	15	15	15
2441	15	15	15
2480	15	15	15

4.2 Carrier Frequency and Channel

Channel	Freq. (MHz)	Channel	Freq. (MHz)	Channel	Freq. (MHz)	Channel	Freq. (MHz)
0	2402	20	2422	40	2442	60	2462
1	2403	21	2423	41	2443	61	2463
2	2404	22	2424	42	2444	62	2464
3	2405	23	2425	43	2445	63	2465
4	2406	24	2426	44	2446	64	2466
5	2407	25	2427	45	2447	65	2467
6	2408	26	2428	46	2448	66	2468
7	2409	27	2429	47	2449	67	2469
8	2410	28	2430	48	2450	68	2470
9	2411	29	2431	49	2451	69	2471
10	2412	30	2432	50	2452	70	2472
11	2413	31	2433	51	2453	71	2473
12	2414	32	2434	52	2454	72	2474
13	2415	33	2435	53	2455	73	2475
14	2416	34	2436	54	2456	74	2476
15	2417	35	2437	55	2457	75	2477
16	2418	36	2438	56	2458	76	2478
17	2419	37	2439	57	2459	77	2479
18	2420	38	2440	58	2460	78	2480
19	2421	39	2441	59	2461		

4.3 Test Operation and Test Software

Setup for testing: Test samples are provided with a USB interface which makes it possible to control them through a test software installed on a notebook computer.

This software was running on the laptop computer connected to the EUT. It was used to enable the operation modes listed as below.

Test Software	AVServe.exe
---------------	-------------

The samples were used as follows:

A002923011-047

A002923011-030

Full test was applied on all test modes, but only worst case was shown.

EUT Configure Mode	Applicable To			Mains Conducted Emission	Description
	Antenna Port Conducted Measurement	Radiated Spurious Emissions above 1 GHz	Radiated Spurious Emissions below 1 GHz		
-	√	√	√	√	-

Note:

1. For Radiated emission test, pre-tested GFSK, π/4-DQPSK, 8DPSK modulation type and found GFSK was the worse, therefore chosen for the final test and presented in the test report.
2. The EUT had been pre-tested on the positioned of each 3 axis. The worst case was found when position on **Z-plane**.
3. "-" means no effect.

Antenna Port Conducted Measurement:

Pre-Scan full test was applied on all test modes, but only worst case was shown.

Following channel(s) was (were) selected for the final test as listed below.

EUT Configure Mode	Available Frequency (MHz)	Tested Frequency (MHz)	Modulation Type	Packet Type
-	2402 to 2480	2402, 2441, 2480	GFSK	1DH5
-	2402 to 2480	2402, 2441, 2480	8DPSK	3DH5

Radiated Spurious Emissions (Above 1 GHz):

Pre-Scan full test was applied on all test modes, but only worst case was shown.

Following channel(s) was (were) selected for the final test as listed below.

EUT Configure Mode	Available Frequency (MHz)	Tested Frequency (MHz)	Modulation Type	Packet Type
-	2402 to 2480	2402, 2441, 2480	GFSK	1DH5
-	2402 to 2480	2402, 2441, 2480	8DPSK	3DH5

Radiated Spurious Emissions (Below 1 GHz):

Pre-Scan full test was applied on all test modes, but only worst case was shown.

Following channel(s) was (were) selected for the final test as listed below.

EUT Configure Mode	Available Frequency (MHz)	Tested Frequency (MHz)	Modulation Type	Packet Type
-	2402 to 2480	2480	GFSK	1DH5

Mains Conducted Emission Test:

Pre-Scan full test was applied on all test modes, but only worst case was shown.

Following channel(s) was (were) selected for the final test as listed below.

EUT Configure Mode	Available Frequency (MHz)	Tested Frequency (MHz)	Modulation Type	Packet Type
-	2402 to 2480	2480	GFSK	1DH5

Test Condition

Test Item	Ambient Temperature	Relative Humidity	Tested by
Conducted Measurement	23.6 - 24.3 °C	62.8 - 64.8 %	Stanislas Charles
Radiated Spurious Emissions above 1 GHz	22 °C	55.4 %	Simon Tsai
Radiated Spurious Emissions below 1 GHz	22 °C	55.4 %	Simon Tsai
Mains Conducted Emission	26 °C	65 %	Kay Wu

4.4 Special Accessories and Auxiliary Equipment

The product has been tested together with the following additional accessories:

Accessory of EUT

No.	Product	Brand	Model	Description
A	USB Cable	AUDEZE	Penrose P RX Penrose X RX	300 cm shielded cable w/o core
-	Microphone	AUDEZE	Penrose P RX Penrose X RX	--

Support Unit

Support Unit					
No.	Description	Brand	Model	S/N	Remark
1	Notebook	HP	15s-du0007TX	CND93662VF	--
2	Adapter	HP	TPN-CA16	N/A	--

Interface Cable					
No.	Description	Shielded Type	Ferrite Core (Qty)	Length (cm)	Remark
2	Adapter Cable	NO	0	180	--

4.5 Test Setup Diagram

<Radiated Spurious Emissions mode>

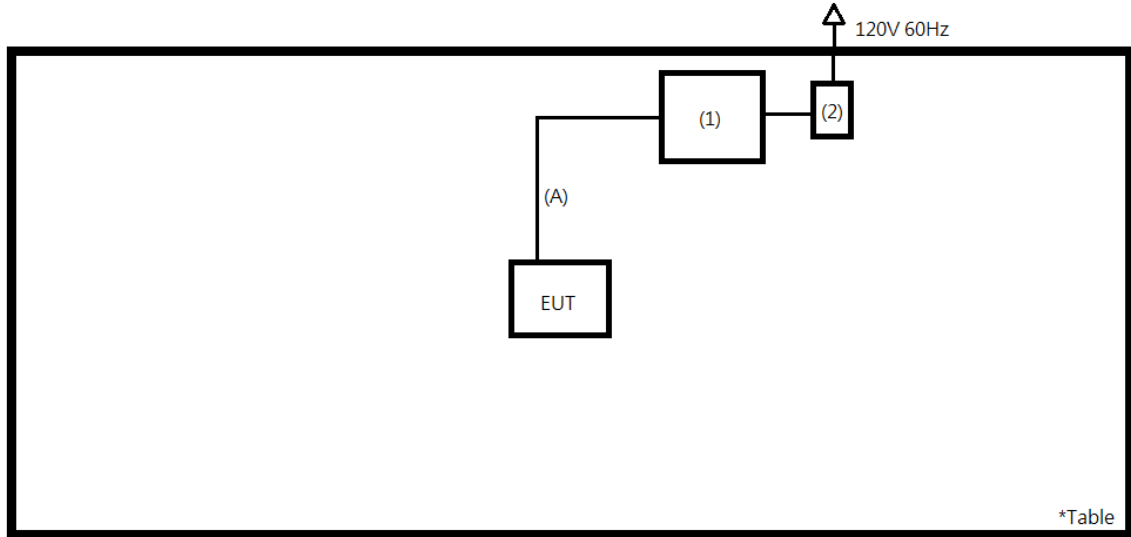

<Mains Conducted Emission mode>

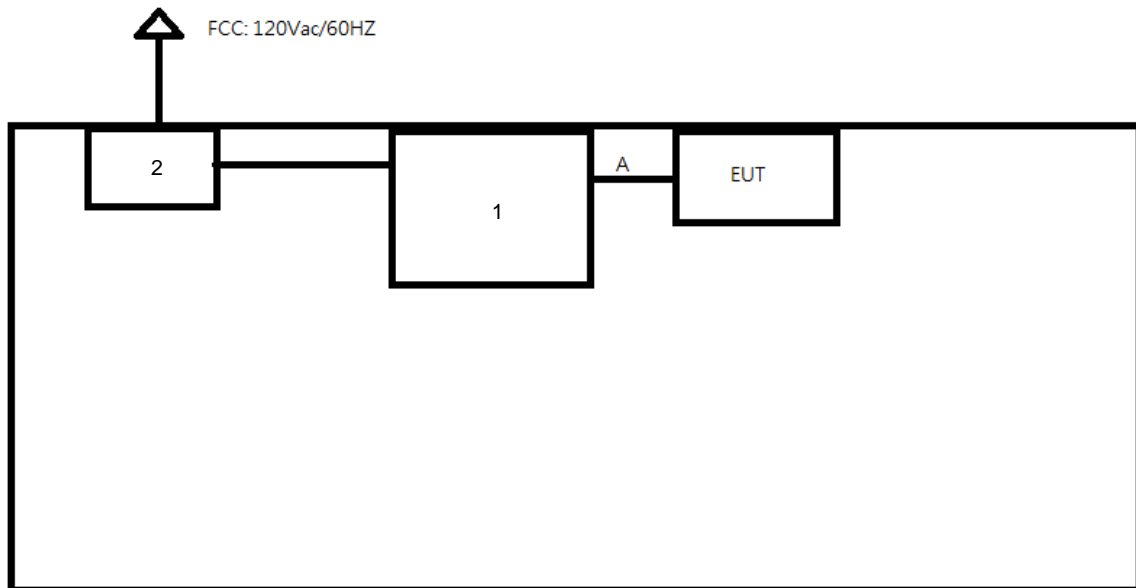

5. Test Results

5.1 Transmitter Requirement & Test Suites

5.1.1 Antenna Requirement

Requirement Use of approved antennas only

According to the manufacturer declaration, the EUT has an antenna with a directional gain of 3 dBi. The antenna is a printed PCB trace with no possibility of replacement with a non-approved antenna by the end-user. Therefore, the EUT is considered to comply with this provision.

There are two chip antennas (Ant 1 and Ant 2) use for 2.4GHz function and supports SISO mode only. PIFA (Ant 3) is use for Bluetooth function.

Bluetooth function and 2.4GHz function will not transmitter at same time.

Refer to EUT photo for details.

5.1.2 Peak Output Power

Limit

For frequency hopping systems operating in the 2400-2483.5 MHz band employing at least 75 non-overlapping hopping channels, and all frequency hopping systems in the 5725-5850 MHz band: 1 watt.
 For all other frequency hopping systems in the 2400-2483.5 MHz band: 0.125 watts.

Kind of Test Site Shielded room

Test Setup

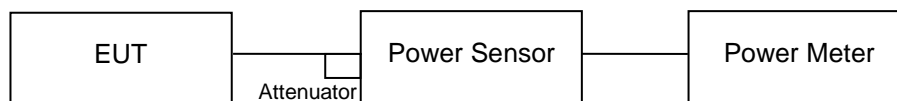

Test Instruments

Kind of Equipment	Manufacturer	Type	S/N	Calibration Date	Calibration Due Date
Power Meter	Anritsu	ML2495A	1901008	2020/4/6	2021/4/5
Power Sensor	Anritsu	MA2411B	1725269	2020/4/7	2021/4/6

Test Procedures

A peak power sensor was used on the output port of the EUT. A power meter was used to read the response of the peak power sensor. Record the power level.

Average power sensor was used to perform output power measurement, trigger and gating function of wide band power meter is enabled to measure max output power of TX on burst. Duty factor is not added to measured value.

Test Result
Peak Output Power
<GFSK>

Channel	Channel Frequency	Peak Output Power		Limit
	(MHz)	(dBm)	(mW)	(mW)
Low Channel	2402	3.04	2.01	125
Middle Channel	2441	2.55	1.80	125
High Channel	2480	2.05	1.60	125

<8DPSK>

Channel	Channel Frequency	Peak Output Power		Limit
	(MHz)	(dBm)	(mW)	(mW)
Low Channel	2402	4.88	3.08	125
Middle Channel	2441	4.11	2.58	125
High Channel	2480	3.67	2.33	125

Average Power
<GFSK>

Channel	Channel Frequency	Average Power	
	(MHz)	(dBm)	(mW)
Low Channel	2402	2.98	1.99
Middle Channel	2441	2.50	1.78
High Channel	2480	2.00	1.58

<8DPSK>

Channel	Channel Frequency	Average Power	
	(MHz)	(dBm)	(mW)
Low Channel	2402	2.82	1.91
Middle Channel	2441	2.29	1.69
High Channel	2480	1.83	1.52

5.1.3 20 dB Bandwidth and 99% Occupied Bandwidth

Kind of Test Site Shielded room

Test Setup

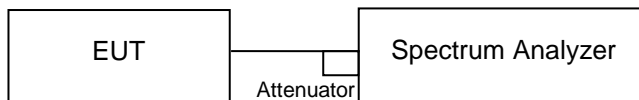

Test Instruments

Kind of Equipment	Manufacturer	Type	S/N	Calibration Date	Calibration Due Date
Spectrum Analyzer	R&S	FSV40	101512	2020/2/18	2021/2/16

Test Procedure

- a. Check the calibration of the measuring instrument using either an internal calibrator or a known signal from an external generator.
- b. Turn on the EUT and connect it to measurement instrument. Then set it to any one convenient frequency within its operating range. Set a reference level on the measuring instrument equal to the highest peak value.
- c. Measure the frequency difference of two frequencies that were attenuated 20 dB from the reference level. Record the frequency difference as the emission bandwidth.
- d. Repeat above procedures until all frequencies measured were complete.
- e. The transmitter output was connected to the spectrum analyzer through an attenuator. The bandwidth of the fundamental frequency was measured by spectrum analyzer with resolution bandwidth in the range of 1 % to 5 % of the anticipated emission bandwidth, and a video bandwidth at least 3x the resolution bandwidth and set the detector to PEAK. The width of a frequency band such that, below the lower and above the upper frequency limits, the mean powers emitted are each equal to a specified percentage 0.5 % of the total mean power of a given emission.

Test Results

Please refer to Appendix A.

5.1.4 Conducted Spurious Emissions and Frequency Band Edges Measured in 100kHz Bandwidth

Limit

20dB (below that in the 100 kHz bandwidth within the band that contains the highest level of the desired power.)

Kind of Test Site Shielded room

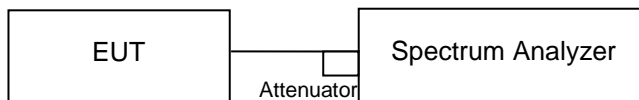
Test Setup

Test Instruments

Kind of Equipment	Manufacturer	Type	S/N	Calibration Date	Calibration Due Date
Spectrum Analyzer	R&S	FSV40	101512	2020/2/18	2021/2/16

Test Procedure

The transmitter output was connected to the spectrum analyzer via a low lose cable. Set both RBW and VBW of spectrum analyzer to 100 kHz and 300 kHz with suitable frequency span including 100 MHz bandwidth from band edge. The band edges was measured and recorded.

Test Results

Please refer to Appendix A.

5.1.5 Radiated Spurious Emissions and Band Edges

Limit

Radiated emissions which fall in the restricted bands, as defined in §15.205(a), must comply with the radiated emission limits specified in §15.209(a).

Emissions radiated outside the restricted and authorized frequency bands must either comply with the radiated emission limits specified for the restricted bands or in §15.247(d).

Kind of Test Site 3m Semi-Anechoic Chamber

Test Setup

<Radiated Emissions below 30 MHz>

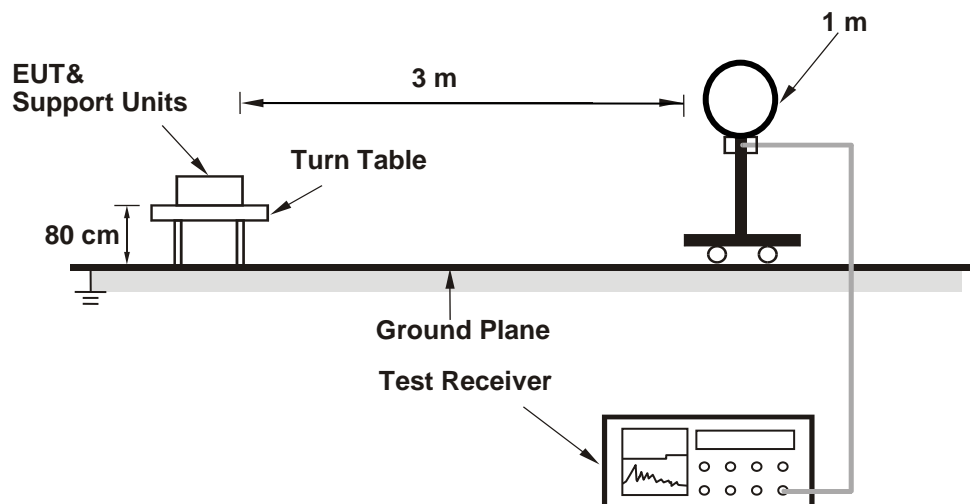

<Radiated Emissions 30 MHz to 1 GHz>

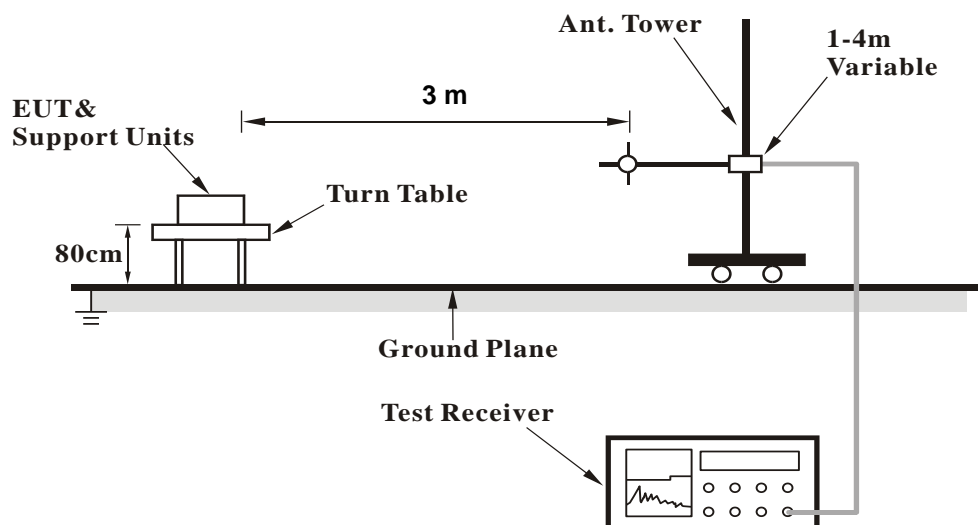

<Radiated Emissions above 1 GHz>

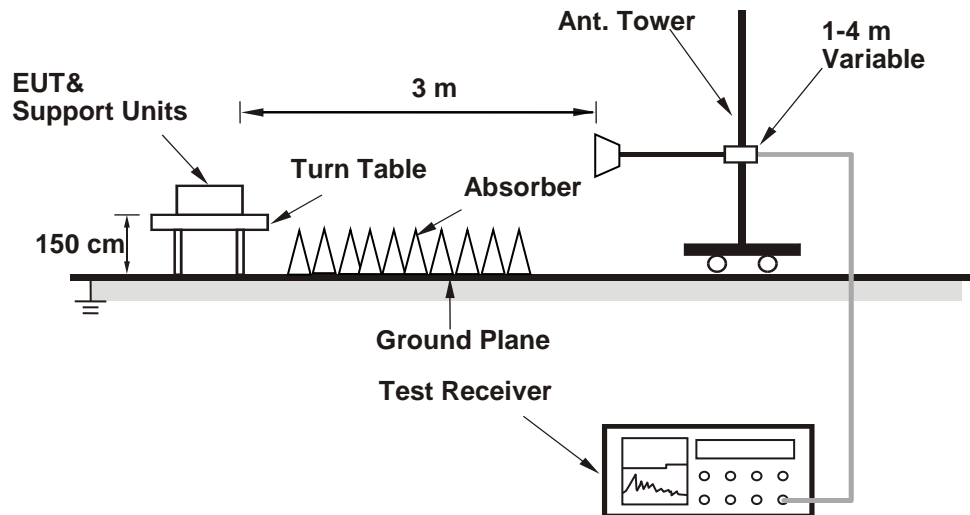

For the actual test configuration, please refer to the attached file (Test Setup Photo).

Test Instruments

Kind of Equipment	Manufacturer	Type	S/N	Calibration Date	Calibration Due Date
Signal Analyzer	R&S	FSV40	101508	2020/3/16	2021/3/15
Receiver	R&S	ESR7	102108	2020/4/22	2021/4/21
Bilog Antenna	SCHWARZBECK	VULB-9168	00951	2020/2/14	2021/2/13
Horn Antenna	ETS-Lindgren	3117	00218930	2019/12/6	2020/12/5
LF-AMP	Agilent	8447D	2944A10772	2020/2/11	2021/2/10
HF-AMP + AC source	EMCI	EMC051845SE	980633	2020/2/17	2021/2/16
HF-AMP + AC source	EMCI	EMC184045SE	980657	2020/2/17	2021/2/16
Horn Antenna	SCHWARZBECK	BBHA 9170	00887	2020/4/10	2021/4/9
Microwave Cable	HUBER+SUHNER	SUCOFLEX 104EA	800056/4EA	2020/3/25	2021/3/24
Microwave Cable	HUBER+SUHNER	SUCOFLEX 104	804680/4	2020/3/25	2021/3/24
Microwave Cable	HUBER+SUHNER	SUCOFLEX 104	MY37202/4	2020/3/25	2021/3/24
Microwave Cable	HUBER+SUHNER	SUCOFLEX 102EA	800898/2EA	2020/4/22	2021/4/21
Microwave Cable	HUBER+SUHNER	SUCOFLEX 102EA	800901/2EA	2020/4/22	2021/4/21
Microwave Cable	HUBER+SUHNER	SUCOFLEX 102EA	801027/2EA	2020/4/22	2021/4/21
Loop Antenna	Chance Most	EMCILPA600 +calibration	287	2020/1/9	2021/1/8

Test Procedures**For Radiated Emissions below 30 MHz**

- a. The EUT was placed on the top of a rotating table 0.8 meters above the ground at a 3 meter chamber room. The table was rotated 360 degrees to determine the position of the highest radiation.
- b. The EUT was set 3 meters away from the interference-receiving antenna, which was mounted on the top of a variable-height antenna tower.
- c. Parallel, perpendicular, and ground-parallel orientations of the antenna are set to make the measurement.
- d. For each suspected emission, the EUT was arranged to its worst case and the rotatable table was turned from 0 degrees to 360 degrees to find the maximum reading.
- e. The test-receiver system was set to Quasi-Peak Detect Function and Specified Bandwidth with Maximum Hold Mode.

Note:

1. The resolution bandwidth and video bandwidth of test receiver/spectrum analyzer is 9 kHz at frequency below 30 MHz.
2. All modes of operation were investigated and the worst-case emissions are reported.

For Radiated Emissions above 30 MHz

- a. The EUT was placed on the top of a rotating table 0.8 meters (for 30 MHz ~ 1 GHz) / 1.5 meters (for above 1 GHz) above the ground at 3 meter chamber room for test. The table was rotated 360 degrees to determine the position of the highest radiation.
- b. The EUT was set 3 meters away from the interference-receiving antenna, which was mounted on the top of a variable-height antenna tower.
- c. The height of antenna is varied from one meter to four meters above the ground to determine the maximum value of the field strength. Both horizontal and vertical polarizations of the antenna are set to make the measurement.
- d. For each suspected emission, the EUT was arranged to its worst case and then the antenna was tuned to heights from 1 meter to 4 meters and the rotatable table was turned from 0 degrees to 360 degrees to find the maximum reading.
- e. The test-receiver system was set to quasi-peak detect function and specified bandwidth with maximum hold mode when the test frequency is below 1 GHz.
- f. The test-receiver system was set to peak and average detected function and specified bandwidth with maximum hold mode when the test frequency is above 1 GHz. If the peak reading value also meets average limit, measurement with the average detector is unnecessary.

Note:

1. The resolution bandwidth and video bandwidth of test receiver/spectrum analyzer is 120 kHz for Quasi-peak detection (QP) or Peak detection (PK) at frequency below 1 GHz.
2. The resolution bandwidth of test receiver/spectrum analyzer is 1 MHz and the video bandwidth is 3 MHz for Peak detection (PK) at frequency above 1 GHz.
3. The resolution bandwidth of test receiver/spectrum analyzer is 1 MHz and the video bandwidth is $\geq 1/T$ (Duty cycle < 98 %) or 10 Hz (Duty cycle ≥ 98 %) for Average detection (AV) at frequency above 1 GHz.
4. All modes of operation were investigated and the worst-case emissions are reported.
5. The Radiated Emissions testing was performed in the X, Y and Z axis orientation. The worst-case Axis orientation is recorded in this test report.

Prüfbericht - Nr.: CN20WS3V (P15C-BT) 001
Test Report No.

Seite 24 von 30
Page 24 of 30

Test Results

Factor (dB/m) = Antenna Factor (dB/m) + Cable Loss (dB)
Level (dBuV/m) = Reading (dBuV) + Factor (dB/m)

Please refer to Appendix B.

5.1.6 Hopping Channel Separation

Limit ≥ 25 kHz or 2/3 of 20 dB bandwidth, whichever is greater

Kind of Test Site Shielded room

Test Setup

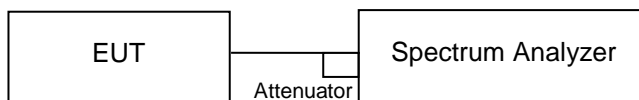

Test Instruments

Kind of Equipment	Manufacturer	Type	S/N	Calibration Date	Calibration Due Date
Spectrum Analyzer	R&S	FSV40	101512	2020/2/18	2021/2/16

Test Procedure

Measurement Procedure REF

- a. Check the calibration of the measuring instrument using either an internal calibrator or a known signal from an external generator.
- b. Turn on the EUT and connect it to measurement instrument. Then set it to any one convenient frequency within its operating range.
- c. By using the MaxHold function record the separation of two adjacent channels.
- d. Measure the frequency difference of these two adjacent channels by SA MARK function. And then plot the result on SA screen.
- e. Repeat above procedures until all frequencies measured were complete.

Test Results

Please refer to Appendix A.

5.1.7 Number of Hopping Frequency

Limit ≥ 15 non-overlapping channels

Kind of Test Site Shielded room

Test Setup

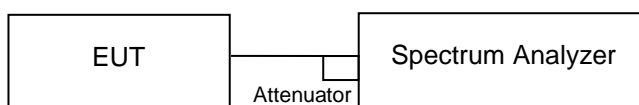

Test Instruments

Kind of Equipment	Manufacturer	Type	S/N	Calibration Date	Calibration Due Date
Spectrum Analyzer	R&S	FSV40	101512	2020/2/18	2021/2/16

Test Procedure

- a. Check the calibration of the measuring instrument (SA) using either an internal calibrator or a known signal from an external generator.
- b. Turn on the EUT and connect its antenna terminal to measurement via a low loss cable. Then set it to any one measured frequency within its operating range and make sure the instrument is operated in its linear range.
- c. Set the SA on MaxHold Mode, and then keep the EUT in hopping mode. Record all the signals from each channel until each one has been recorded.
- d. Set the SA on View mode and then plot the result on SA screen.
- e. Repeat above procedures until all frequencies measured were complete.

Test Results

Please refer to Appendix A.

5.1.8 Dwell Time

Limit 0.4s

Kind of Test Site Shielded room

Test Setup

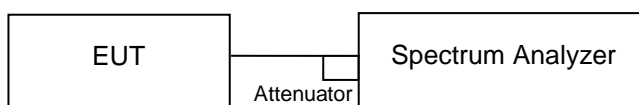

Test Instruments

Kind of Equipment	Manufacturer	Type	S/N	Calibration Date	Calibration Due Date
Spectrum Analyzer	R&S	FSV40	101512	2020/2/18	2021/2/16

Test Procedures

- Check the calibration of the measuring instrument (SA) using either an internal calibrator or a known signal from an external generator.
- Turn on the EUT and connect its antenna terminal to measurement via a low loss cable. Then set it to any one measured frequency within its operating range and make sure the instrument is operated in its linear range.
- Adjust the center frequency of SA on any frequency be measured and set SA to zero span mode. And then, set RBW and VBW of spectrum analyzer to proper value.
- Measure the time duration of one transmission on the measured frequency. And then plot the result with time difference of this time duration.
- Repeat above procedures until all different time-slot modes have been completed.

Test Results

Please refer to Appendix A.

5.2 Mains Emission

5.2.1 Mains Conducted Emission

Limit

Mains Conducted Emission as defined in §15.207 must comply with the mains conducted emission limits.

Kind of Test Site Shielded room

Test Setup

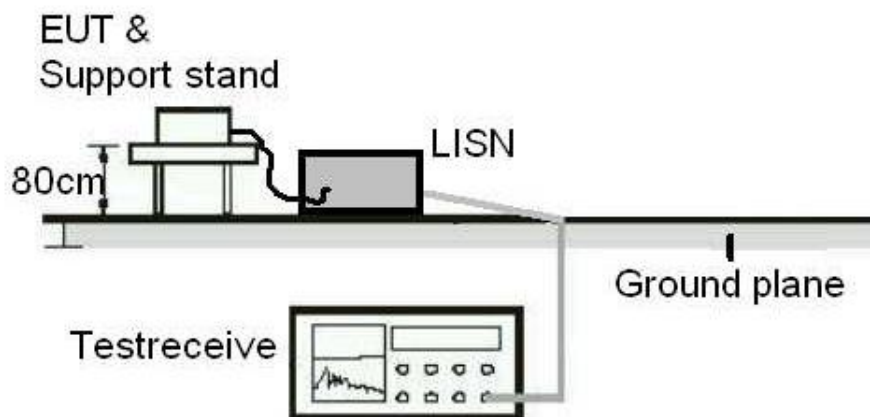

Test Instruments

Kind of Equipment	Manufacturer	Type	S/N	Calibration Date	Calibration Due Date
EMI Test Receiver	Rohde & Schwarz	ESR 7	102114	2020/04/13	2021/04/13
Two-Line V-Network (for EUT)	Rohde & Schwarz	ENV216	101262	2020/08/04	2021/08/04
Pulse Limiter	Schwarzbeck	VTSD 9561 F-N	00660	2020/02/24	2021/02/24
Test Software	Audix	e3	Ver. 9	N/A	N/A

Test Procedures

- a. The EUT was placed 0.4 meters from the conducting wall of the shielded room with EUT being connected to the power mains through a line impedance stabilization network (LISN). Other support units were connected to the power mains through another LISN. The two LISNs provide 50 ohm/50 uH of coupling impedance for the measuring instrument.
- b. Both lines of the power mains connected to the EUT were checked for maximum conducted interference.
- c. The frequency range from 150 kHz to 30 MHz was searched. Emission levels under (Limit – 20 dB) was not recorded.

Note: The resolution bandwidth and video bandwidth of test receiver is 9 kHz for quasi-peak detection (QP) and average detection (AV) at frequency 0.15 MHz – 30 MHz.

Test Results

Please refer to Appendix B.

6. Safety Human exposure

6.1 RF Exposure Compliance

6.1.1 SAR Test Exclusion Thresholds

Results

Since the maximum output power of the transmitter is $1.99 \text{ mW} < 10 \text{ mW}$ (Distance: 5 mm), hence the EUT is excluded from SAR evaluation according to FCC KDB publication 447498 D01: Mobile Portable RF Exposure.

Appendix A: Test Results of Conducted Test

Test Result of 20 dB Bandwidth

GFSK

Channel	Channel Frequency (MHz)	20 dB Bandwidth (kHz)	Result
Low Channel	2402	968.03	Pass
Middle Channel	2441	1117.88	Pass
High Channel	2480	959.04	Pass

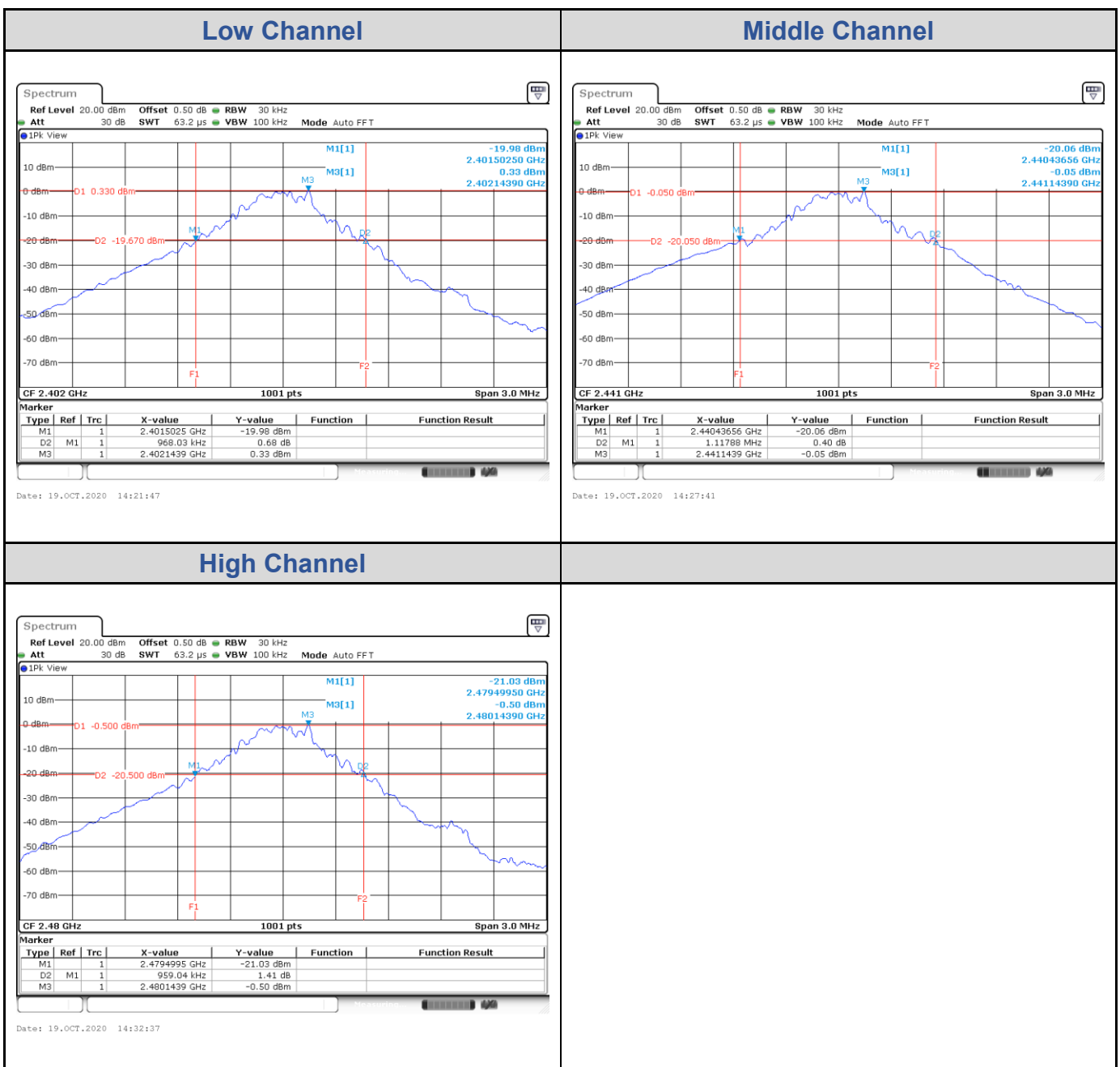

8DPSK

Channel	Channel Frequency (MHz)	20 dB Bandwidth (kHz)	Result
Low Channel	2402	1327.67	Pass
Middle Channel	2441	1333.67	Pass
High Channel	2480	1330.70	Pass

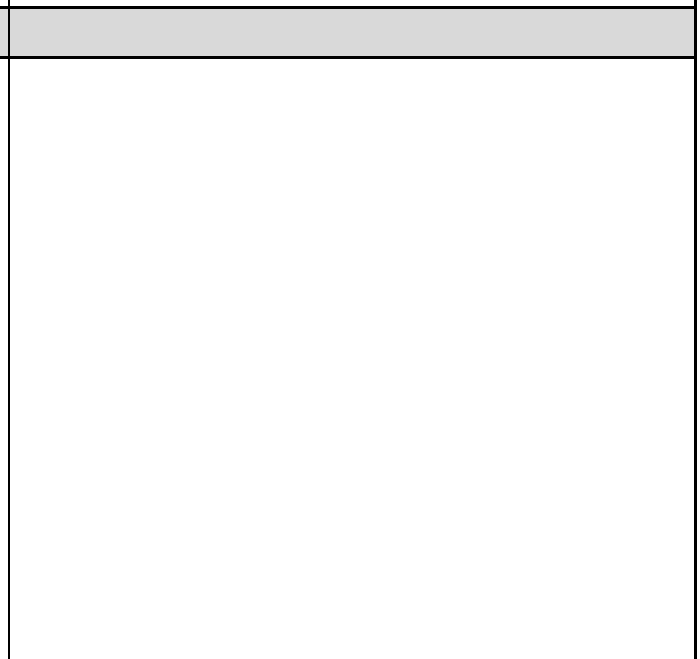
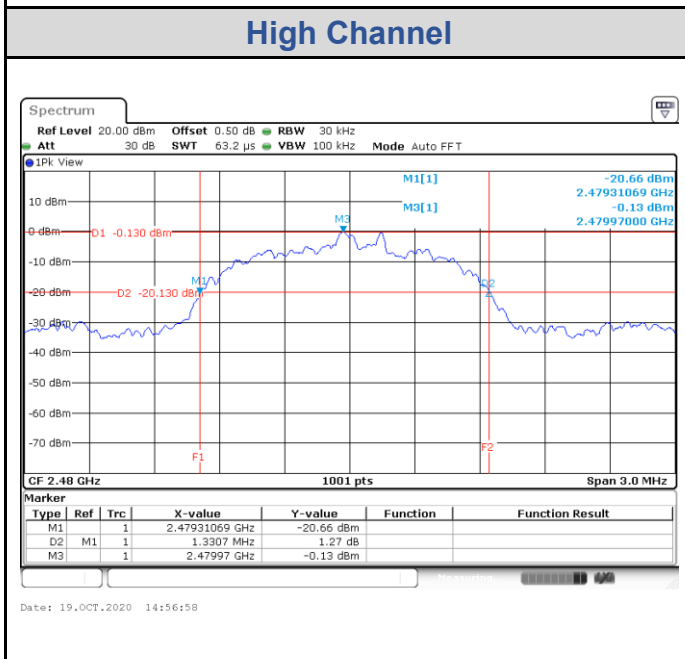
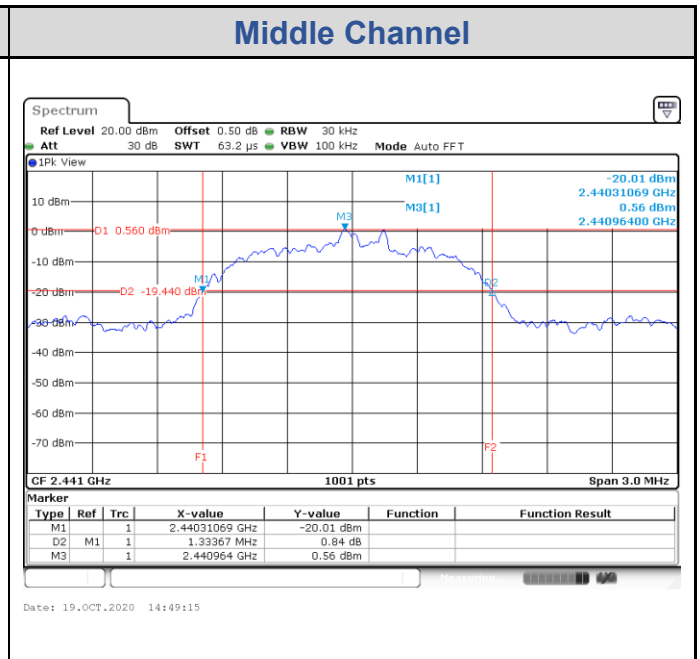
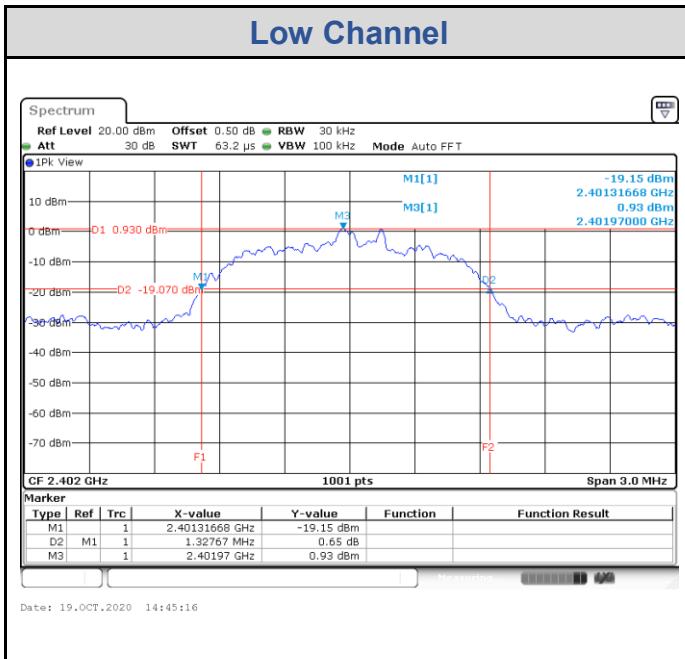

Test Result of 99% Occupied Bandwidth

GFSK

Channel	Channel Frequency (MHz)	99% Bandwidth (kHz)
Low Channel	2402	896.10
Middle Channel	2441	1108.89
High Channel	2480	893.11

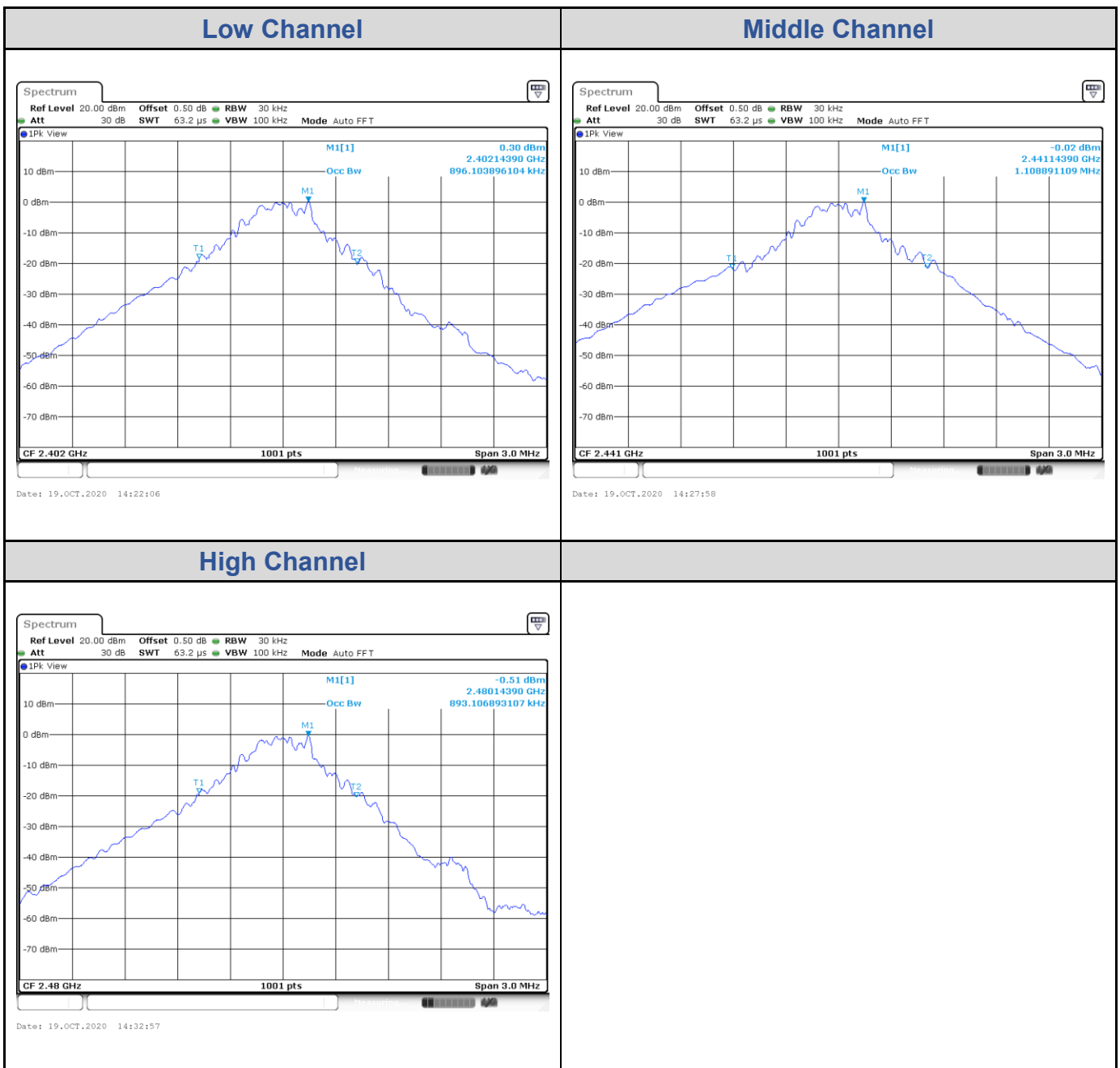

8DPSK

Channel	Channel Frequency (MHz)	99% Bandwidth (kHz)
Low Channel	2402	1255.74
Middle Channel	2441	1258.74
High Channel	2480	1246.75

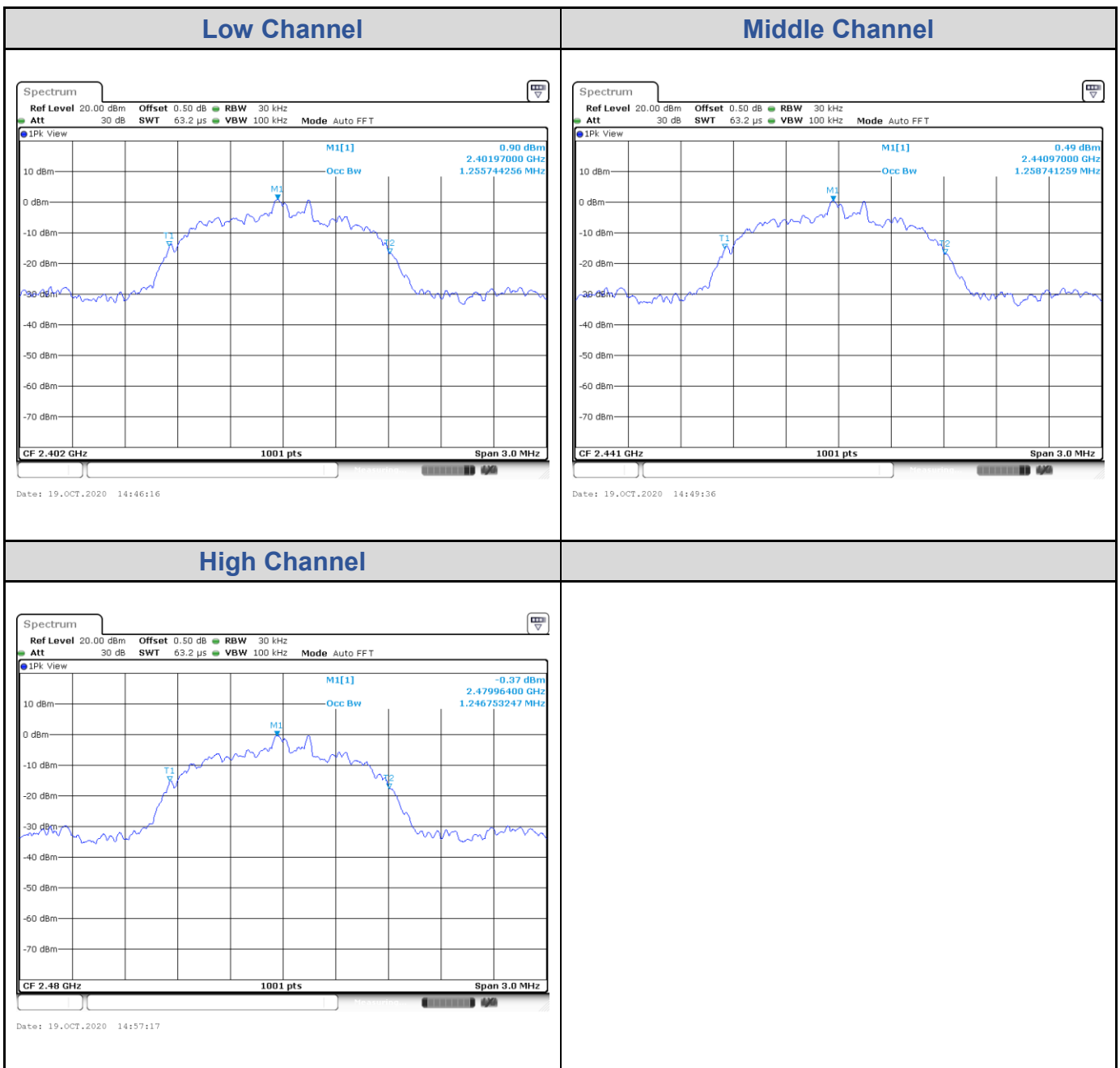

Test Result of Conducted Spurious Emissions, Tx Mode

GFSK

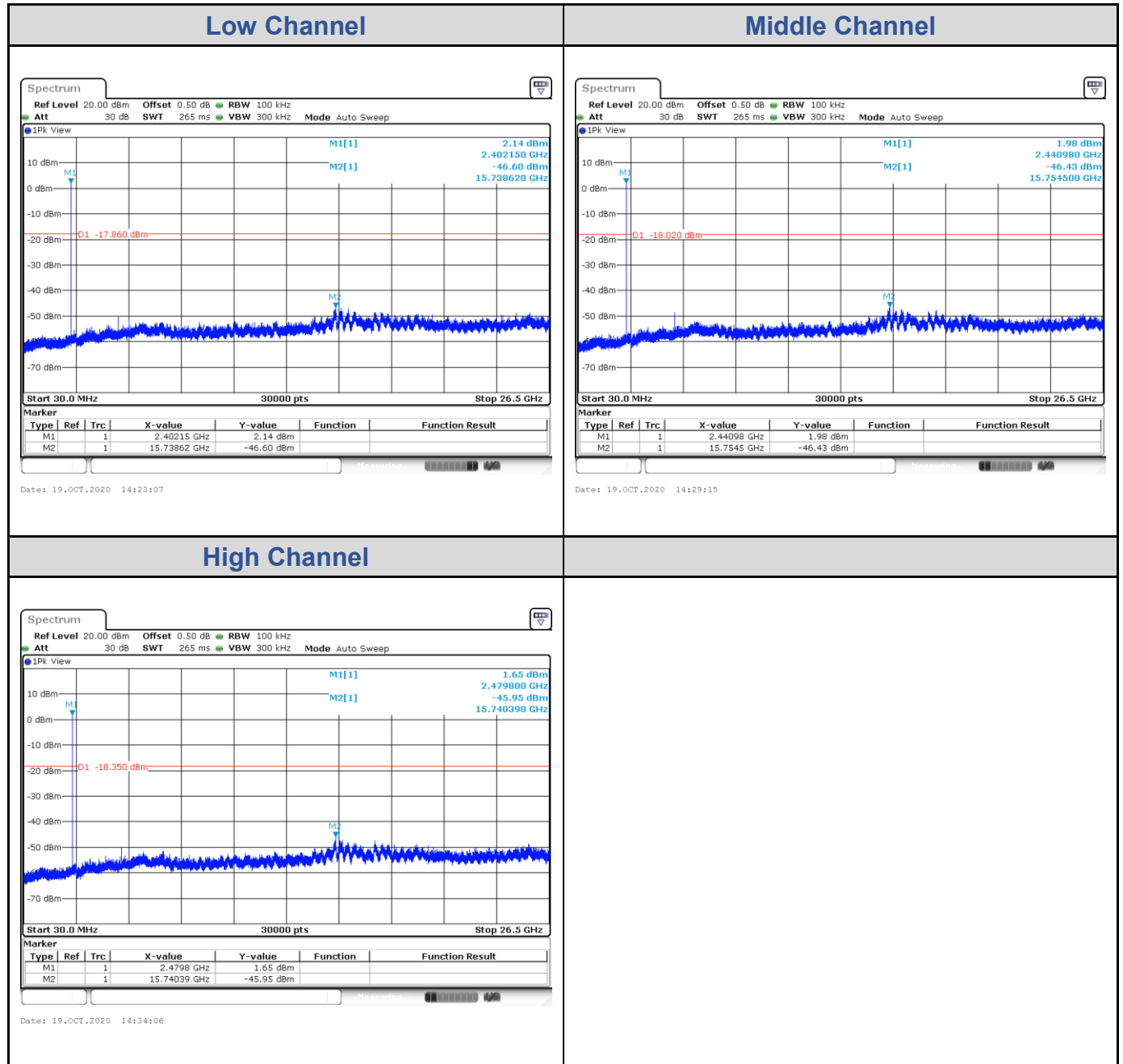

8DPSK

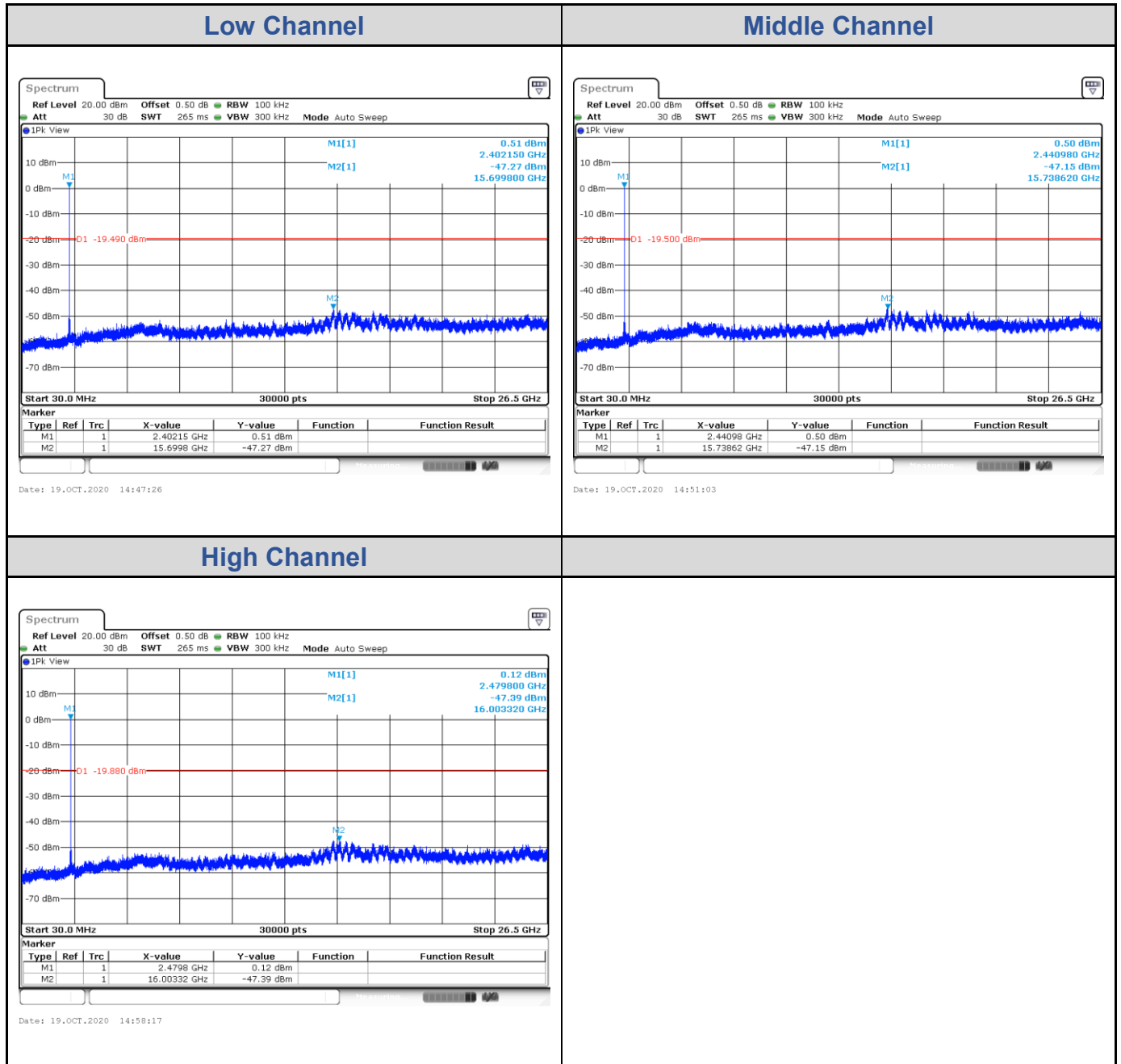

Test Result of Conducted Band Edge, Tx Mode

GFSK

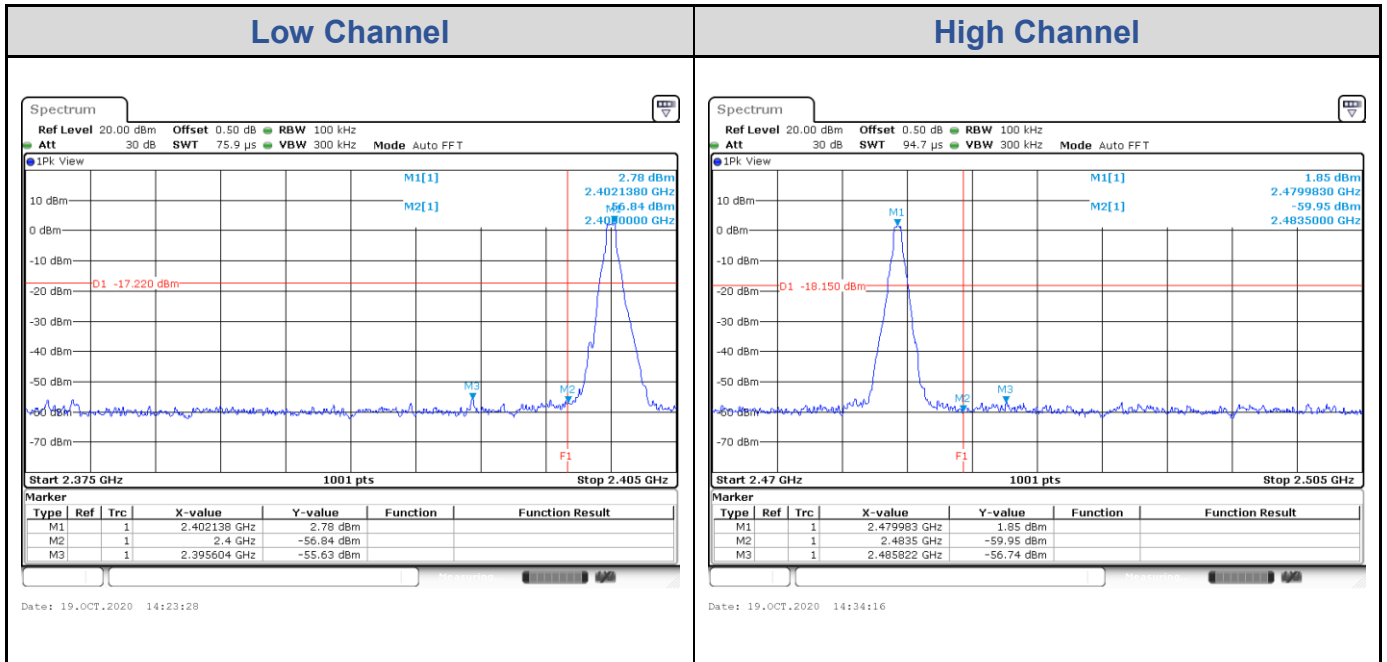

8DPSK

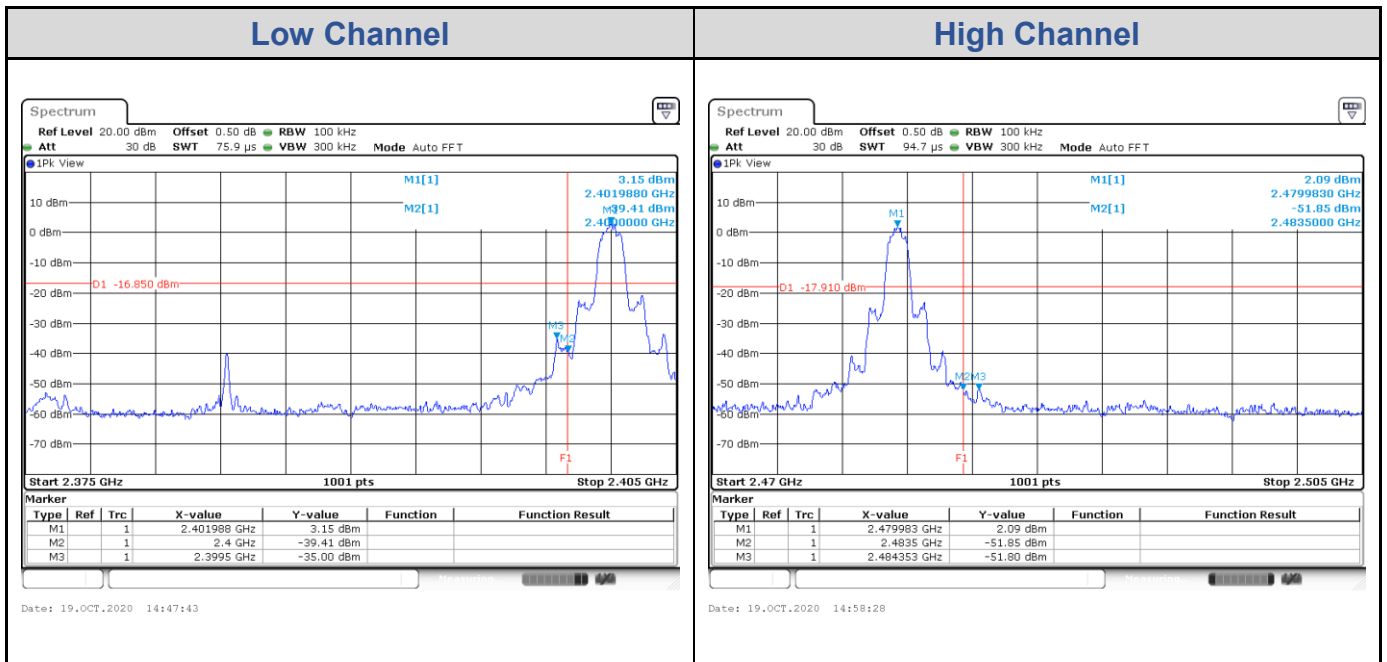

Test Result of Hopping Band Edge

GFSK

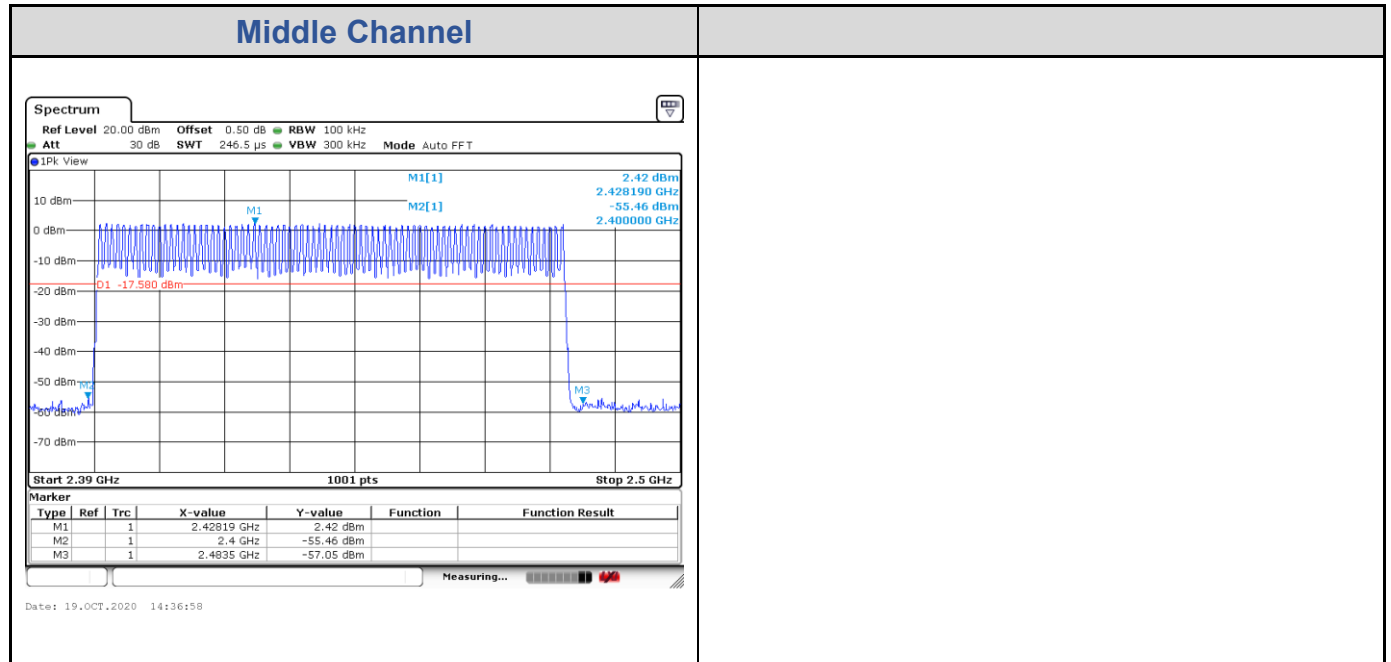

8DPSK

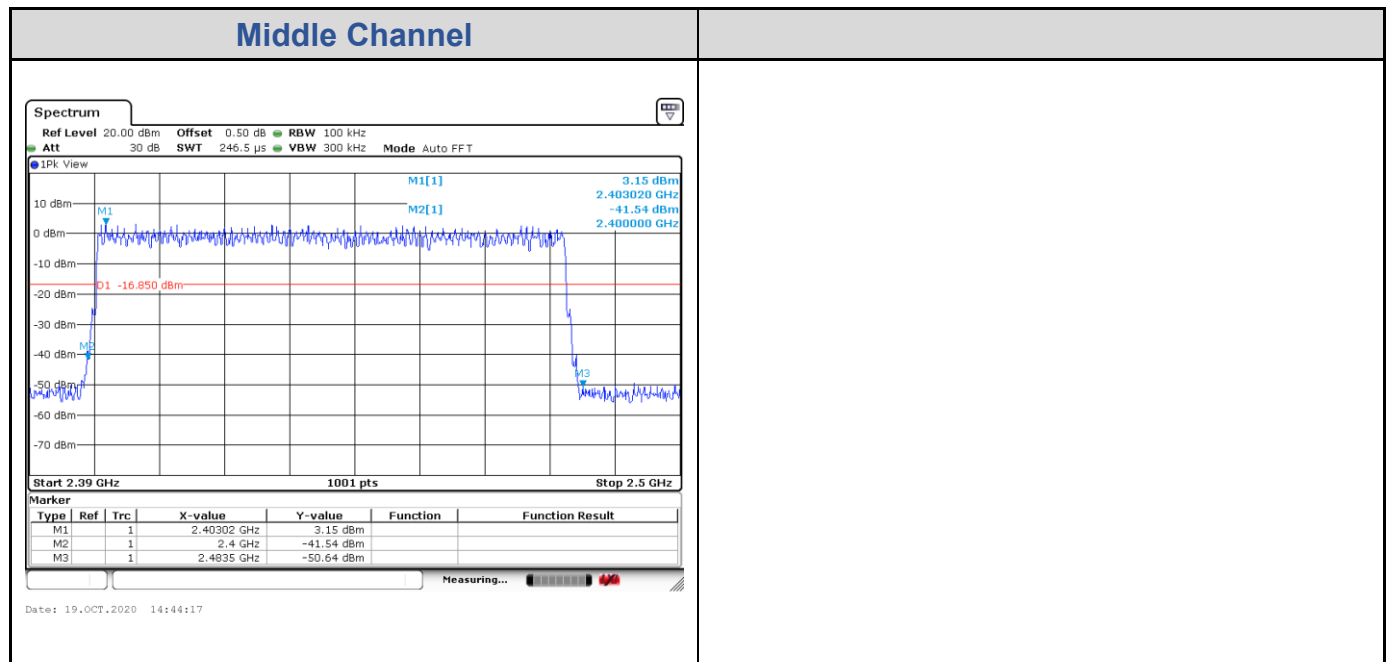

Test Result of Hopping Channel Separation

GFSK

Channel	Channel Frequency (MHz)	Adjacent Channel Separation (MHz)	20 dB Bandwidth (kHz)	Minimum Limit (MHz)	Result
0	2402	1.00	968.03	0.645	Pass
39	2441	1.00	1117.88	0.745	Pass
78	2480	1.00	959.04	0.639	Pass

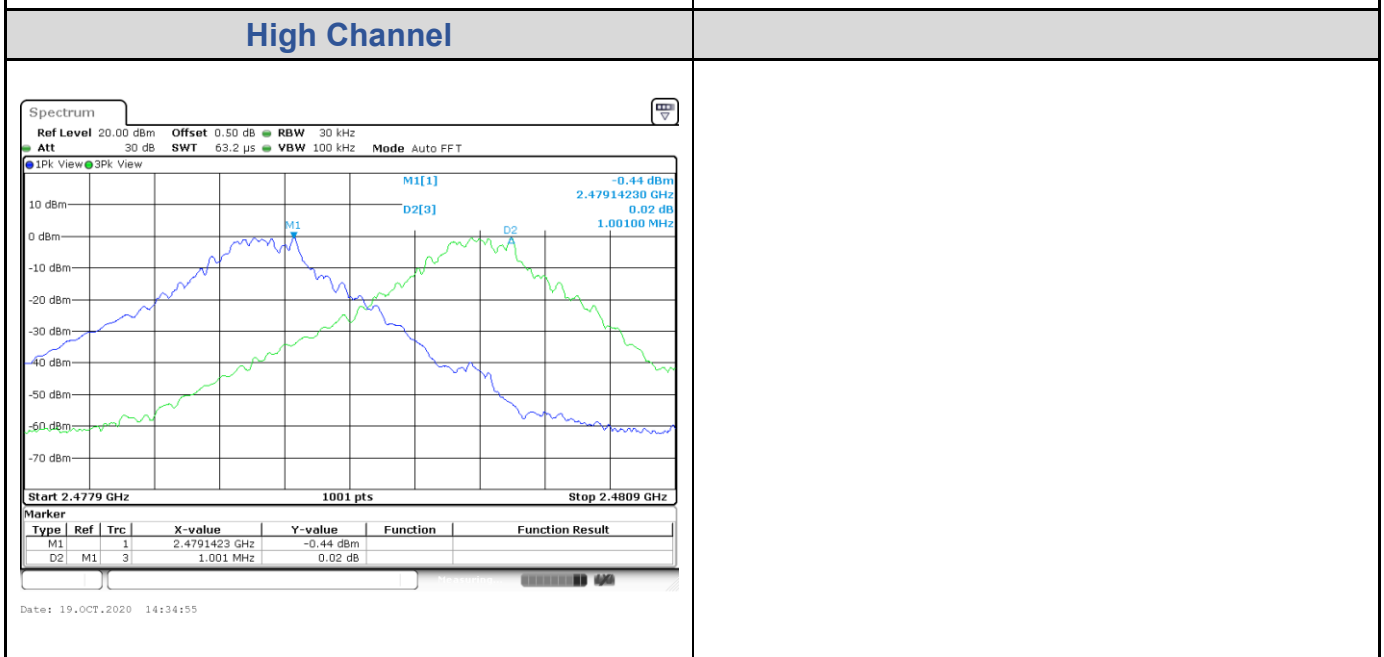
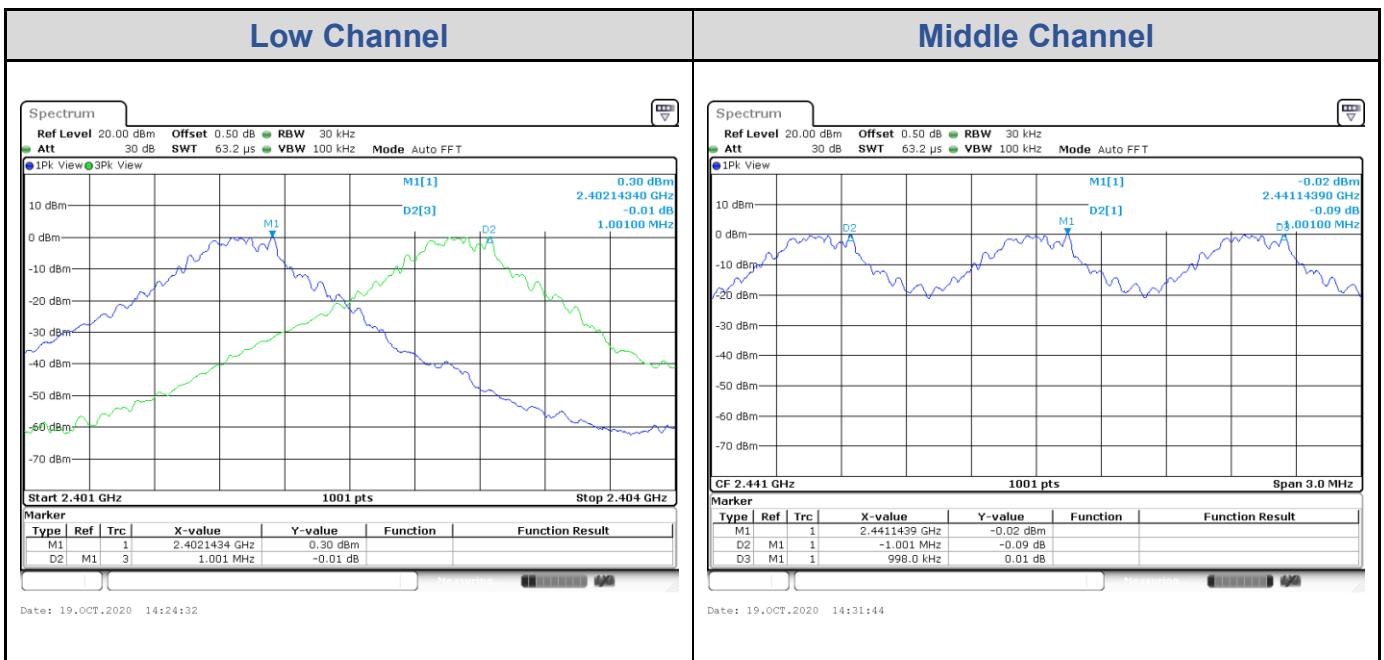

8DPSK

Channel	Channel Frequency (MHz)	Adjacent Channel Separation (MHz)	20 dB Bandwidth (kHz)	Minimum Limit (MHz)	Result
0	2402	1.00	1327.67	0.885	Pass
39	2441	1.00	1333.67	0.889	Pass
78	2480	1.00	1330.70	0.887	Pass

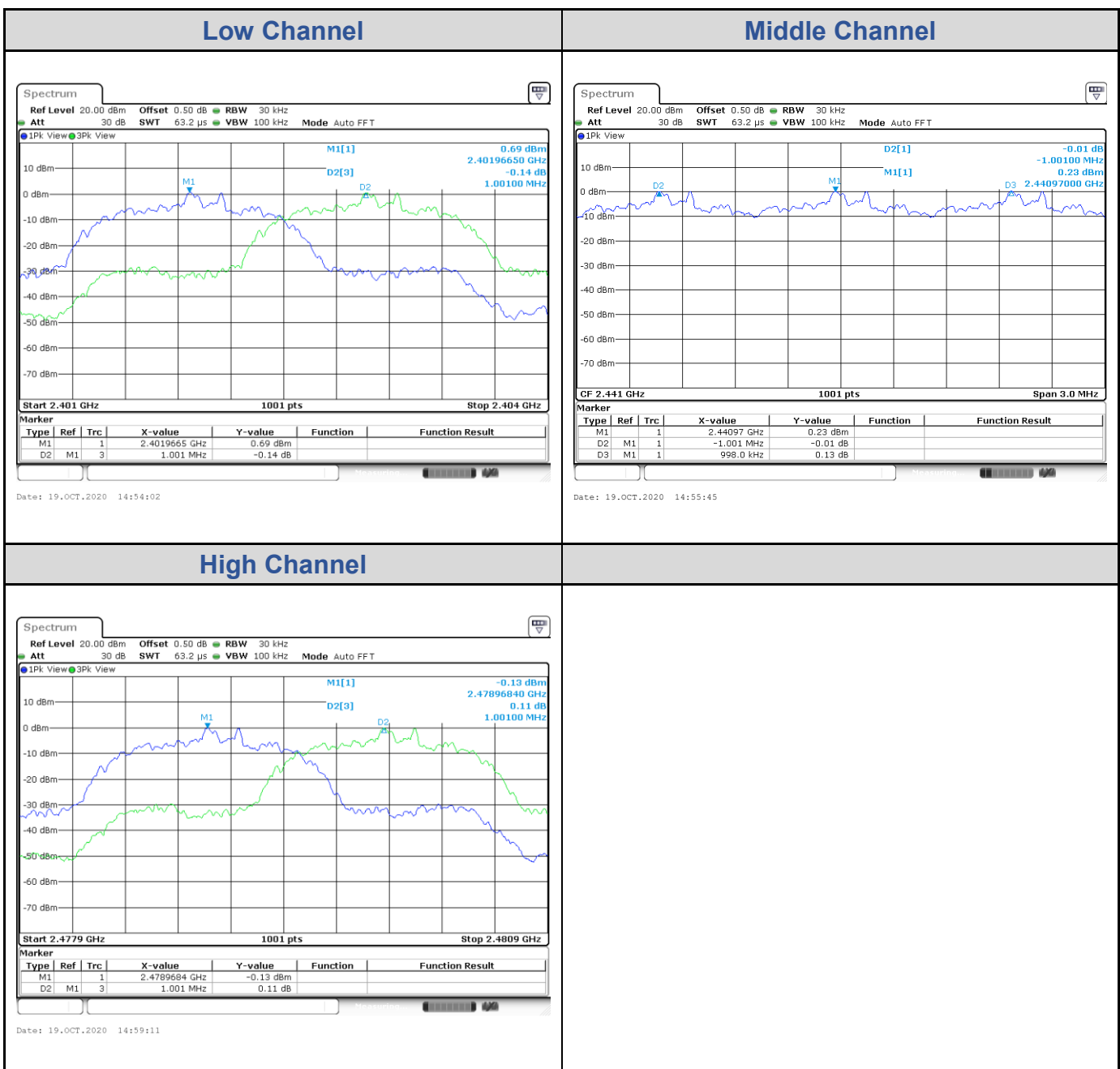

Test Result of Number of Hopping Frequency

Frequency Range	Measured Quantity of Hopping Channel	Limit	Result
2400 to 2483.5 MHz	79	≥15	Pass

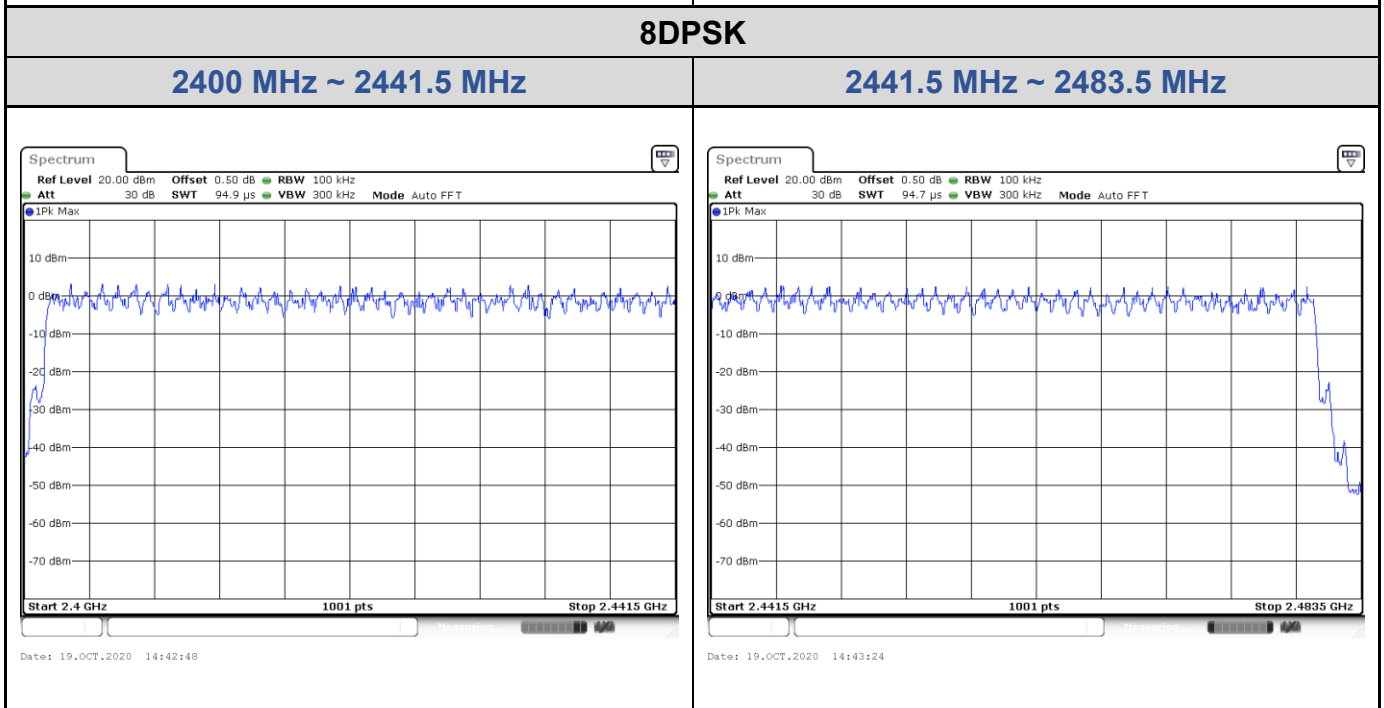
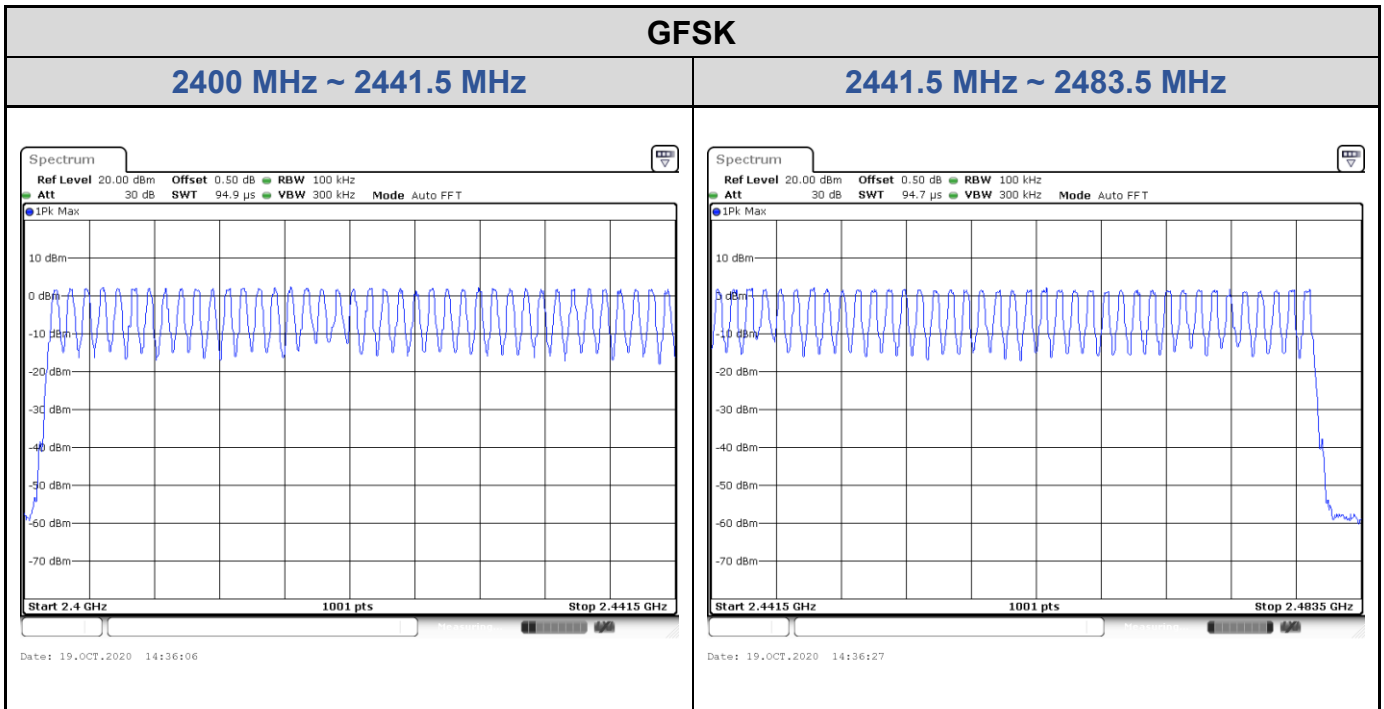

Test Result of Dwell Time

GFSK

Data Mode	Number of transfer in a 31.6 (79Hopping*0.4s)	Package transfer time (msec)	Dwell time (s)	Limit (s)	Result
1DH5	15 (times / 5 sec) * 6.32 = 94.8 times	2.915	0.276	0.4	Pass

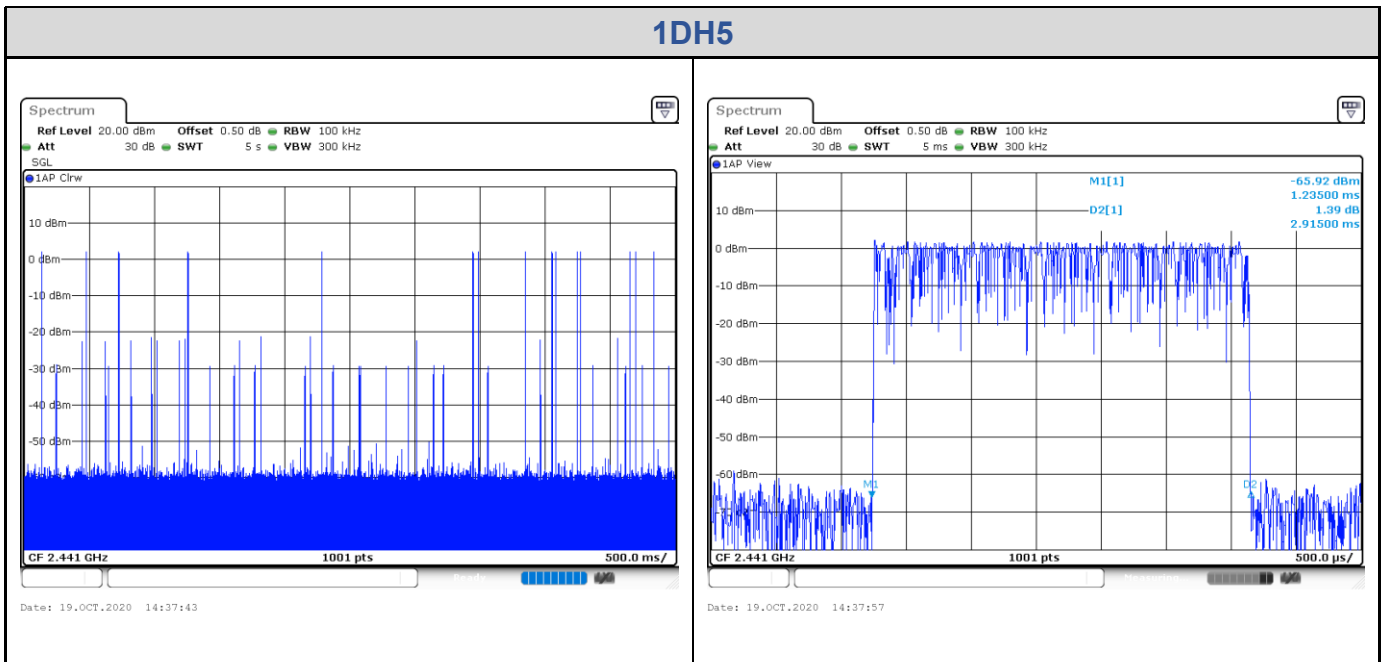

8DPSK

Data Mode	Number of transfer in a 31.6 (79Hopping*0.4s)	Package transfer time (msec)	Dwell time (s)	Limit (s)	Result
3DH5	17 (times / 5 sec) * 6.32 = 107.44 times	2.94	0.316	0.4	Pass

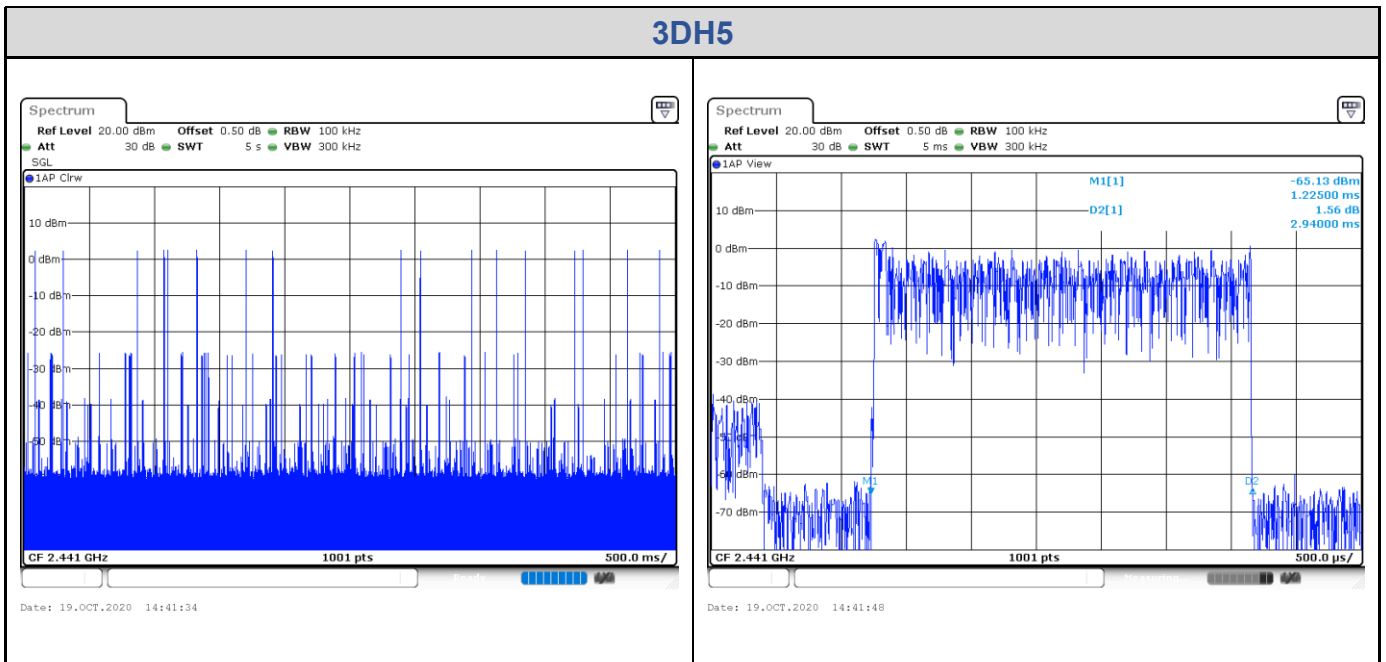

Appendix B: Test Results of Radiated Emissions & Mains Conducted

Emission Test

Band Edges, 2.31GHz ~ 2.9GHz

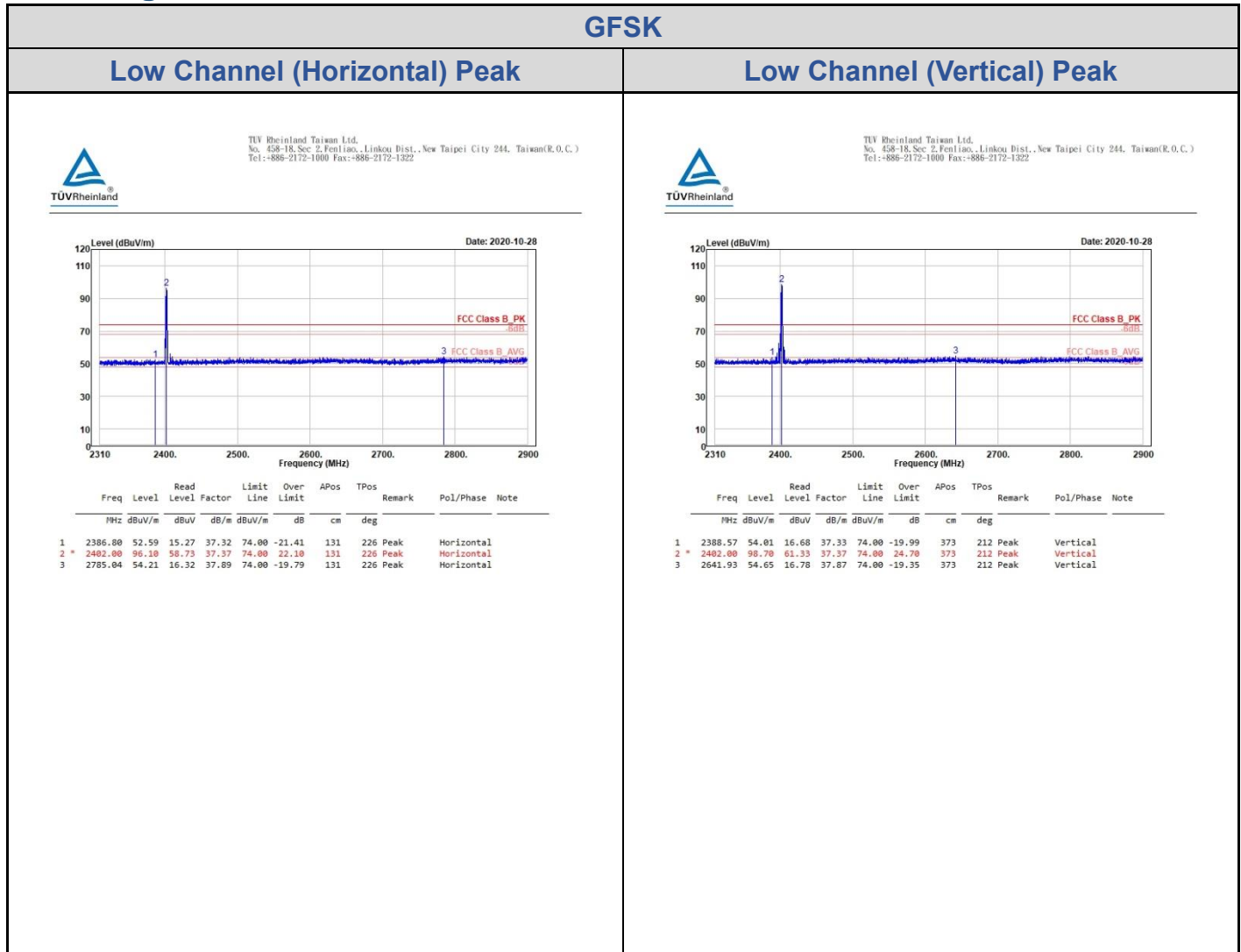

GFSK

Low Channel (Horizontal) Average

Low Channel (Vertical) Average



TUV Rheinland Taiwan Ltd.
No. 458-18, Sec. 2, Fenhiao, Linkou Dist., New Taipei City 244, Taiwan(R.O.C.)
Tel: +886-2172-1000 Fax: +886-2172-1322

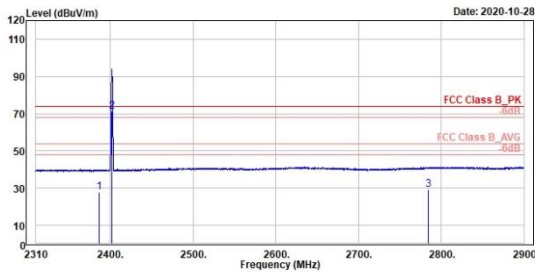

Freq	Level	Read Level	Factor	Limit Line	Over Limit	APos	TPos	Remark	Pol/Phase	Note
MHz	dBuV/m	dBuV	dB/m	dBuV/m	dB	cm	deg			
1	2386.00	27.79	-9.53	37.32	54.00	-26.21	131	226 Average	Horizontal	DF
2 *	2482.00	71.30	33.93	37.37	54.00	17.30	131	226 Average	Horizontal	DF
3	2785.04	29.41	-8.48	37.89	54.00	-24.59	131	226 Average	Horizontal	DF



TUV Rheinland Taiwan Ltd.
No. 458-18, Sec. 2, Fenhiao, Linkou Dist., New Taipei City 244, Taiwan(R.O.C.)
Tel: +886-2172-1000 Fax: +886-2172-1322

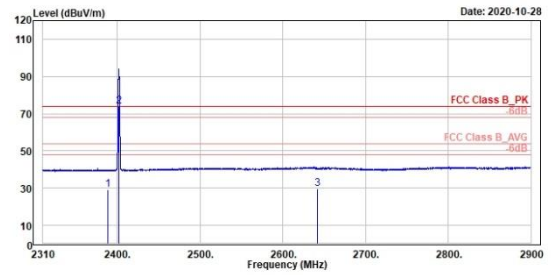

Freq	Level	Read Level	Factor	Limit Line	Over Limit	APos	TPos	Remark	Pol/Phase	Note
MHz	dBuV/m	dBuV	dB/m	dBuV/m	dB	cm	deg			
1	2388.57	29.21	-8.12	37.33	54.00	-24.79	373	212 Average	Vertical	DF
2 *	2482.00	73.90	36.53	37.37	54.00	19.90	373	212 Average	Vertical	DF
3	2641.93	29.85	-8.82	37.87	54.00	-24.15	373	212 Average	Vertical	DF

GFSK

High Channel (Horizontal) Peak

High Channel (Vertical) Peak



TUV Rheinland Taiwan Ltd.
No. 458-18, Sec. 2, Fenhiao, Linkou Dist., New Taipei City 244, Taiwan(R.O.C.)
Tel: +886-2172-1000 Fax: +886-2172-1322

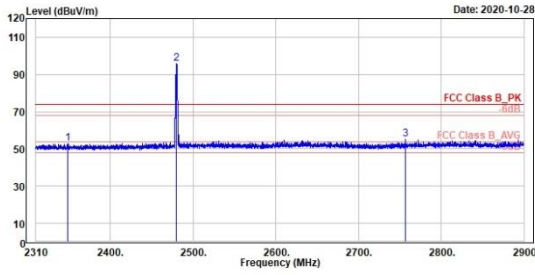

Peak	Freq	Level	Read	Level	Factor	Limit	Over	APos	TPos	Remark	Pol/Phase	Note
	MHz	dBuV/m	dBuV	dB/m	dBuV/m	dB	dB	cm	deg			
1	2348.52	52.77	15.57	37.20	74.00	-21.23	267	268	268	Peak	Horizontal	
2 *	2480.00	95.74	58.18	37.56	74.00	21.74	267	268	268	Peak	Horizontal	
3	2756.77	55.06	17.20	37.86	74.00	-18.94	267	268	268	Peak	Horizontal	



TUV Rheinland Taiwan Ltd.
No. 458-18, Sec. 2, Fenhiao, Linkou Dist., New Taipei City 244, Taiwan(R.O.C.)
Tel: +886-2172-1000 Fax: +886-2172-1322

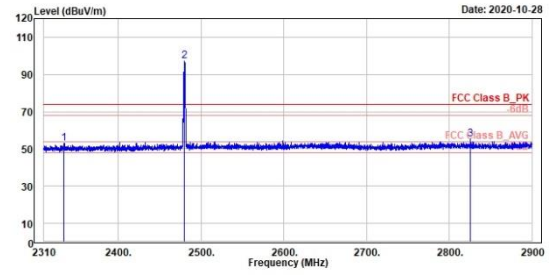

Peak	Freq	Level	Read	Level	Factor	Limit	Over	APos	TPos	Remark	Pol/Phase	Note
	MHz	dBuV/m	dBuV	dB/m	dBuV/m	dB	dB	cm	deg			
1	2333.79	52.91	15.75	37.16	74.00	-21.09	313	0	0	Peak	Vertical	
2 *	2480.00	97.21	59.65	37.56	74.00	23.21	313	0	0	Peak	Vertical	
3	2825.44	55.11	17.12	37.99	74.00	-18.89	313	0	0	Peak	Vertical	

GFSK
High Channel (Horizontal) Average
High Channel (Vertical) Average

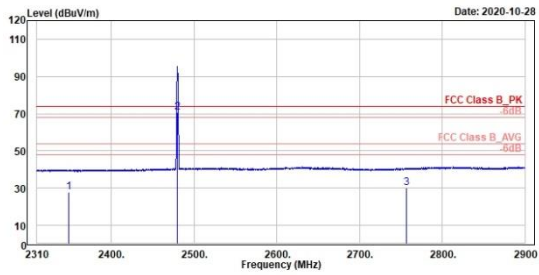

TÜV Rheinland Taiwan Ltd.
 No. 458-18, Sec. 2, Fenhiao, Linkou Dist., New Taipei City 244, Taiwan(R.O.C.)
 Tel: +886-2172-1000 Fax: +886-2172-1322



Freq	Level	Read Level	Factor	Limit Line	Over Limit	APos	TPos	Remark	Pol/Phase	Note
MHz	dBuV/m	dBuV	dB/m	dBuV/m	dB	cm	deg			
1	2348.52	27.97	-9.23	37.20	54.00	-26.03	267	268 Average	Horizontal	DF
2 *	2480.00	70.75	33.19	37.56	54.00	16.75	267	268 Average	Horizontal	DF
3	2756.77	30.26	-7.60	37.86	54.00	-23.74	267	268 Average	Horizontal	DF

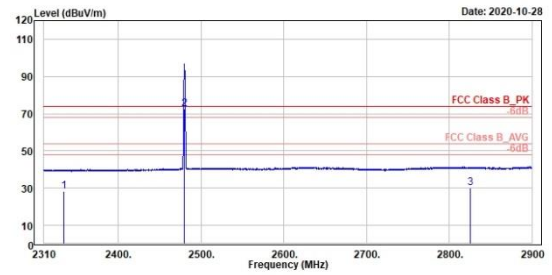

TÜV Rheinland Taiwan Ltd.
 No. 458-18, Sec. 2, Fenhiao, Linkou Dist., New Taipei City 244, Taiwan(R.O.C.)
 Tel: +886-2172-1000 Fax: +886-2172-1322



Freq	Level	Read Level	Factor	Limit Line	Over Limit	APos	TPos	Remark	Pol/Phase	Note
MHz	dBuV/m	dBuV	dB/m	dBuV/m	dB	cm	deg			
1	2333.79	28.10	-9.06	37.16	54.00	-25.90	313	0 Average	Vertical	DF
2 *	2480.00	72.41	34.25	37.56	54.00	18.41	313	0 Average	Vertical	DF
3	2825.44	30.31	-7.68	37.99	54.00	-23.69	313	0 Average	Vertical	DF

8DPSK

Low Channel (Horizontal) Peak

Low Channel (Vertical) Peak

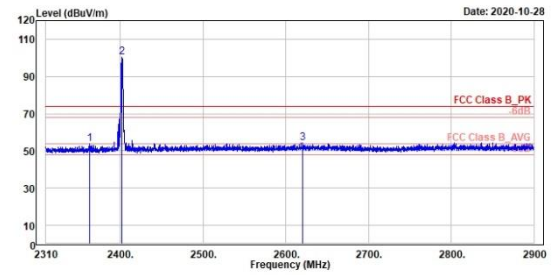
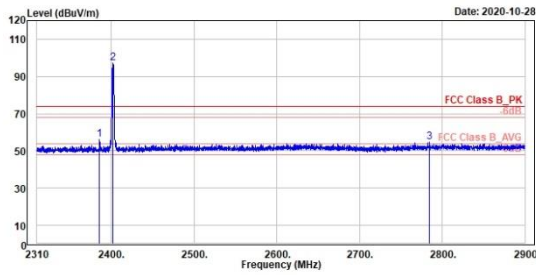

Freq	Level	Read	Level	Factor	Limit	Over	APos	TPos	Remark	Pol/Phase	Note
MHz	dBuV/m	dBuV	dB/m	dBuV/m	dB	cm	deg				
1	2385.74	56.18	18.86	37.32	74.00	-17.82	133	219	Peak	Horizontal	
2 *	2402.00	97.36	59.99	37.37	74.00	23.36	133	219	Peak	Horizontal	
3	2784.80	54.58	16.69	37.89	74.00	-19.42	133	219	Peak	Horizontal	

Freq	Level	Read	Level	Factor	Limit	Over	APos	TPos	Remark	Pol/Phase	Note
MHz	dBuV/m	dBuV	dB/m	dBuV/m	dB	cm	deg				
1	2363.01	53.67	16.42	37.25	74.00	-20.33	323	191	Peak	Vertical	
2 *	2402.00	100.54	63.17	37.37	74.00	26.54	323	191	Peak	Vertical	
3	2620.61	54.21	16.28	37.93	74.00	-19.79	323	191	Peak	Vertical	

8DPSK

Low Channel (Horizontal) Average

Low Channel (Vertical) Average



TUV Rheinland Taiwan Ltd.
No. 458-18, Sec. 2, Fenhiao, Linkou Dist., New Taipei City 244, Taiwan(R.O.C.)
Tel: +886-2172-1000 Fax: +886-2172-1322

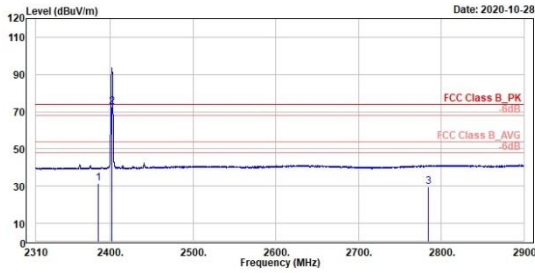

Freq	Level	Read	Level	Factor	Limit	Over	APos	TPos	Remark	Pol/Phase	Note
MHz	dBuV/m	dBuV	dB/m	dBuV/m	dB	dB	cm	deg			
1	2385.74	31.38	-5.94	37.32	54.00	-22.62	133	219	Average	Horizontal	DF
2 *	2482.80	72.56	35.19	37.37	54.00	18.56	133	219	average	Horizontal	DF
3	2784.80	29.78	-8.11	37.89	54.00	-24.22	133	219	Average	Horizontal	DF



TUV Rheinland Taiwan Ltd.
No. 458-18, Sec. 2, Fenhiao, Linkou Dist., New Taipei City 244, Taiwan(R.O.C.)
Tel: +886-2172-1000 Fax: +886-2172-1322

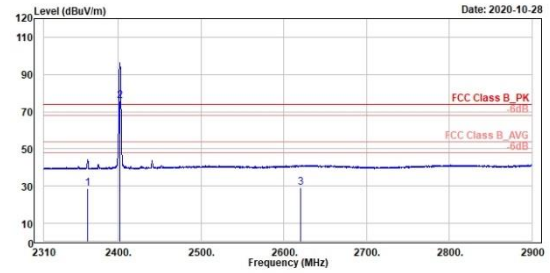

Freq	Level	Read	Level	Factor	Limit	Over	APos	TPos	Remark	Pol/Phase	Note
MHz	dBuV/m	dBuV	dB/m	dBuV/m	dB	dB	cm	deg			
1	2363.81	28.87	-8.38	37.25	54.00	-25.13	323	191	Average	Vertical	DF
2 *	2482.80	75.74	38.37	37.37	54.00	21.74	323	191	Average	Vertical	DF
3	2628.61	29.41	-8.52	37.93	54.00	-24.59	323	191	Average	Vertical	DF

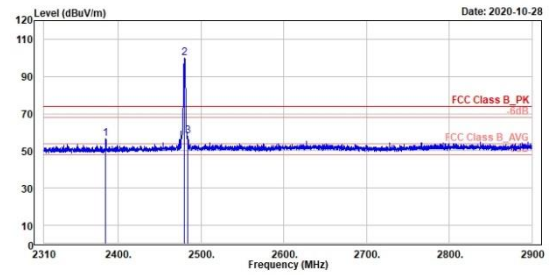
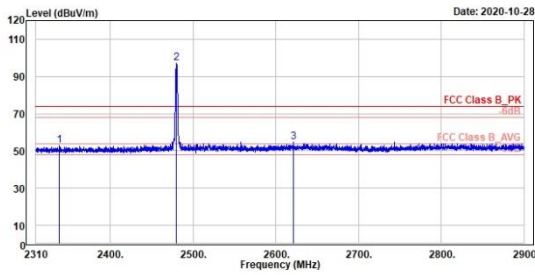
8DPSK
High Channel (Horizontal) Peak
High Channel (Vertical) Peak

Peak	Freq (MHz)	Level (dBuV/m)	Read Level (dBuV)	Level Factor (dB/m)	Limit Line (dBuV/m)	Over Limit (dB)	APos (cm)	TPos (deg)	Remark	Pol/Phase	Note
1	2338.27	52.01	15.64	37.17	74.00	-21.19	267	267	Peak	Horizontal	
2 *	2488.00	97.05	59.49	37.56	74.00	23.05	267	267	Peak	Horizontal	
3	2621.31	54.81	16.89	37.92	74.00	-19.19	267	267	Peak	Horizontal	

Peak	Freq (MHz)	Level (dBuV/m)	Read Level (dBuV)	Level Factor (dB/m)	Limit Line (dBuV/m)	Over Limit (dB)	APos (cm)	TPos (deg)	Remark	Pol/Phase	Note
1	2384.00	56.60	19.28	37.32	74.00	-17.40	342	209	Peak	Vertical	
2 *	2480.00	99.83	62.27	37.56	74.00	25.83	342	209	Peak	Vertical	
3	2483.74	57.06	20.30	37.56	74.00	-16.14	342	209	Peak	Vertical	

8DPSK

High Channel (Horizontal) Average

High Channel (Vertical) Average



TUV Rheinland Taiwan Ltd.
No. 458-18, Sec. 2, Fenhiao, Linkou Dist., New Taipei City 244, Taiwan(R.O.C.)
Tel: +886-2172-1000 Fax: +886-2172-1322

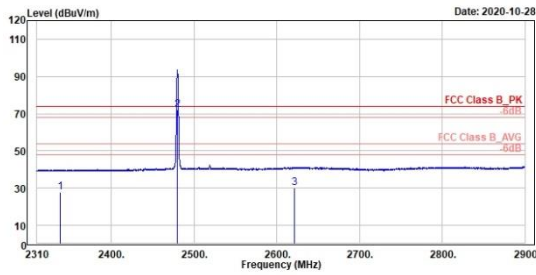

Freq	Level	Read	Level	Factor	Limit	Over	APos	TPos	Remark	Pol/Phase	Note
MHz	dBuV/m	dBuV	dB/m	dB/m	dBuV/m	dB	cm	deg			
1	2338.27	28.01	-9.16	37.17	54.00	-25.99	267	267	Average	Horizontal	DF
2 *	2488.00	72.25	34.69	37.56	54.00	18.25	267	267	Average	Horizontal	DF
3	2621.31	29.99	-7.93	37.92	54.00	-24.01	267	267	Average	Horizontal	DF



TUV Rheinland Taiwan Ltd.
No. 458-18, Sec. 2, Fenhiao, Linkou Dist., New Taipei City 244, Taiwan(R.O.C.)
Tel: +886-2172-1000 Fax: +886-2172-1322

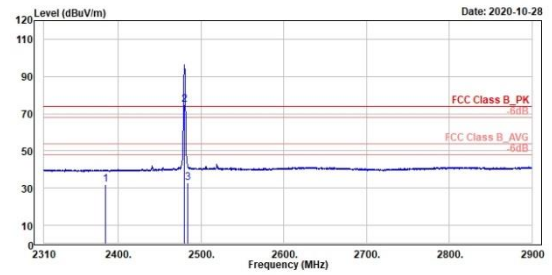

Freq	Level	Read	Level	Factor	Limit	Over	APos	TPos	Remark	Pol/Phase	Note
MHz	dBuV/m	dBuV	dB/m	dB/m	dBuV/m	dB	cm	deg			
1	2384.00	31.00	-5.52	37.32	54.00	-22.20	342	209	Average	Vertical	DF
2 *	2480.00	75.03	37.47	37.56	54.00	21.03	342	209	Average	Vertical	DF
3	2483.74	33.06	-4.50	37.56	54.00	-20.94	342	209	Average	Vertical	DF

Spurious Emissions, Tx Mode, 9kHz ~ 30MHz

GFSK

High Channel(Open) 9kHz~150kHz

High Channel(Open) 150kHz~30MHz



TUV Rheinland Taiwan Ltd.
No. 458-18, Sec. 2, Fenhiao, Linkou Dist., New Taipei City 244, Taiwan(R.O.C.)
Tel: +886-2172-1000 Fax: +886-2172-1322

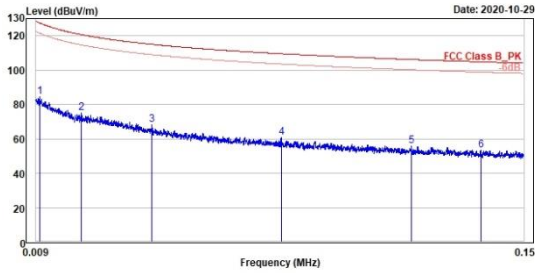

Freq	Level	Read	Limit	Over	Apos	TPos	Remark	Pol/Phase	Note
MHz	dBuV/m	dBuV	dB/m	dBuV/m	dB	cm	deg		
1	84.52	5.70	78.82	127.56	-43.04	100	14	QP	Open
2	75.10	2.94	72.16	120.71	-45.61	100	66	QP	Open
3	68.20	1.28	66.92	115.02	-46.82	100	322	QP	Open
4	60.81	-0.45	61.26	109.54	-48.73	100	271	QP	Open
5	55.62	-2.62	58.24	106.20	-50.58	100	0	QP	Open
6	53.59	-3.48	57.07	104.83	-51.24	100	173	QP	Open



TUV Rheinland Taiwan Ltd.
No. 458-18, Sec. 2, Fenhiao, Linkou Dist., New Taipei City 244, Taiwan(R.O.C.)
Tel: +886-2172-1000 Fax: +886-2172-1322

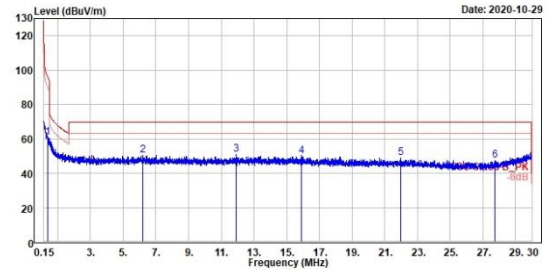

Freq	Level	Read	Limit	Over	Apos	TPos	Remark	Pol/Phase	Note
MHz	dBuV/m	dBuV	dB/m	dBuV/m	dB	cm	deg		
1	60.60	12.29	48.31	95.48	-34.88	100	96	QP	Open
2	50.53	12.18	38.35	69.50	-18.97	100	353	QP	Open
3	50.69	13.40	37.29	69.50	-18.81	100	249	QP	Open
4	50.12	12.57	37.55	69.50	-19.38	100	240	QP	Open
5	49.02	13.14	35.88	69.50	-20.48	100	346	QP	Open
6	47.33	12.41	34.92	69.50	-22.17	100	122	QP	Open

GFSK

High Channel(Close) 9kHz~150kHz

High Channel(Close) 150kHz~30MHz



TUV Rheinland Taiwan Ltd.
No. 458-18, Sec. 2, Fenhiao, Linkou Dist., New Taipei City 244, Taiwan(R.O.C.)
Tel: +886-2172-1000 Fax: +886-2172-1322

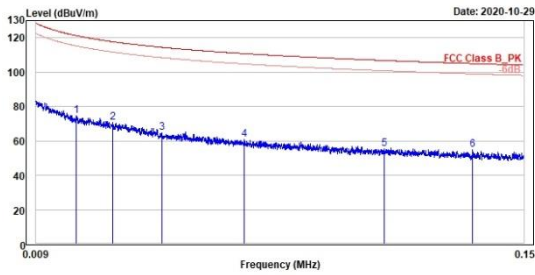

Freq	Level	Read	Level	Factor	Limit	Over	Apos	TPos	Remark	Pol/Phase	Note
MHz	dBuV/m	dBuV	dB/m	dBuV/m	dB	cm	deg				
1	0.02	74.65	2.22	72.43	121.30	-46.65	100	160	QP	Close	
2	0.03	70.66	0.28	70.38	117.72	-47.06	100	2	QP	Close	
3	0.05	64.73	-1.45	66.18	114.44	-49.71	100	72	QP	Close	
4	0.07	60.69	-1.75	62.44	110.78	-50.09	100	208	QP	Close	
5	0.11	55.33	-3.36	58.69	106.79	-51.46	100	172	QP	Close	
6	0.14	54.73	-2.48	57.21	104.98	-50.25	100	191	QP	Close	



TUV Rheinland Taiwan Ltd.
No. 458-18, Sec. 2, Fenhiao, Linkou Dist., New Taipei City 244, Taiwan(R.O.C.)
Tel: +886-2172-1000 Fax: +886-2172-1322

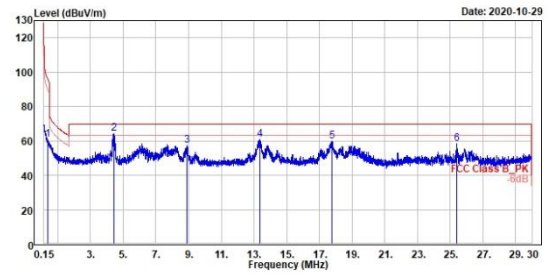

Freq	Level	Read	Level	Factor	Limit	Over	Apos	TPos	Remark	Pol/Phase	Note
MHz	dBuV/m	dBuV	dB/m	dBuV/m	dB	cm	deg				
1	0.38	60.64	11.86	48.78	96.01	-35.37	100	251	QP	Close	
2	4.41	64.07	25.74	38.33	69.50	-5.43	100	32	QP	Close	
3	8.92	57.57	19.77	37.80	69.50	-11.93	100	166	QP	Close	
4	13.37	60.89	23.41	37.48	69.50	-8.61	100	348	QP	Close	
5	17.79	59.98	23.08	36.90	69.50	-9.52	100	14	QP	Close	
6	25.42	58.41	24.29	34.12	69.50	-11.09	100	100	QP	Close	

Spurious Emissions, Tx Mode, 30MHz ~ 1GHz
GFSK
High Channel (Horizontal)
High Channel (Vertical)

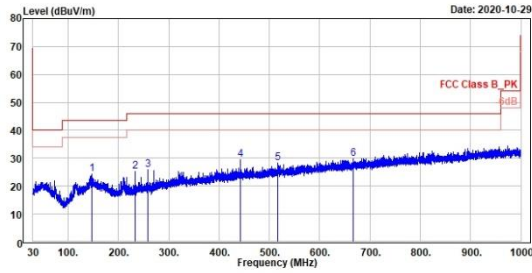

TUV Rheinland Taiwan Ltd.
 No. 458-18, Sec. 2, Fenliao, Linkou Dist., New Taipei City 244, Taiwan(R.O.C.)
 Tel: +886-2172-1000 Fax: +886-2172-1322



Freq	Level	Read	Limit	Over	APos	TPos	Remark	Pol/Phase	Note
MHz	dBuV/m	dBuV	dB/m	dBuV/m	dB	cm	deg		
1	147.47	24.30	31.95	-7.65	43.50	-19.20	200	106 QP	Horizontal
2	233.51	25.19	33.82	-8.63	46.00	-20.81	100	295 QP	Horizontal
3	258.05	25.00	33.69	-7.89	46.00	-20.20	100	68 QP	Horizontal
4	442.35	29.44	33.31	-3.87	46.00	-16.56	100	71 QP	Horizontal
5	516.16	28.15	31.00	-2.85	46.00	-17.85	200	273 QP	Horizontal
6	666.13	29.82	30.32	-0.50	46.00	-16.18	300	253 QP	Horizontal

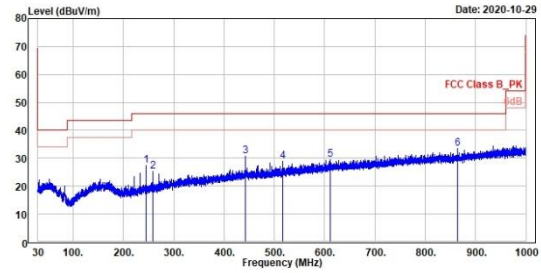

TUV Rheinland Taiwan Ltd.
 No. 458-18, Sec. 2, Fenliao, Linkou Dist., New Taipei City 244, Taiwan(R.O.C.)
 Tel: +886-2172-1000 Fax: +886-2172-1322



Freq	Level	Read	Limit	Over	APos	TPos	Remark	Pol/Phase	Note
MHz	dBuV/m	dBuV	dB/m	dBuV/m	dB	cm	deg		
1	245.83	27.28	35.42	-8.14	46.00	-18.72	200	1 QP	Horizontal
2	258.05	25.37	33.26	-7.89	46.00	-20.63	200	0 QP	Horizontal
3	442.44	30.63	34.50	-3.87	46.00	-15.37	100	257 QP	Horizontal
4	516.07	28.92	31.78	-2.86	46.00	-17.08	100	90 QP	Horizontal
5	610.64	29.44	30.42	-0.98	46.00	-16.56	100	361 QP	Horizontal
6	863.52	33.34	30.77	2.57	46.00	-12.66	300	139 QP	Horizontal

Spurious Emissions, Tx Mode, 1GHz ~ 26.5GHz

GFSK

Low Channel (Horizontal)

Low Channel (Vertical)

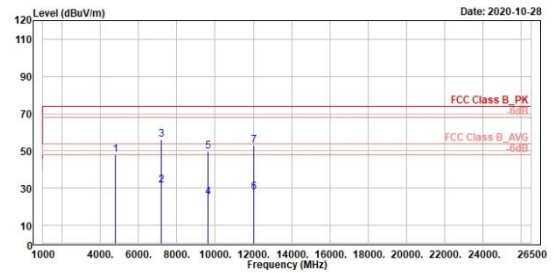
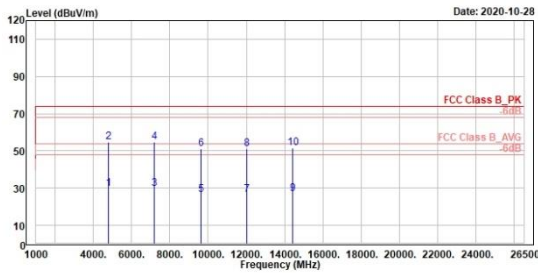

1	2	3	4	5	6	7	8	9	10	
Level	Read	Level	Factor	Limit	Over	Apos	Tpos	Remark	Pol/Phase	Note
dBuV/m	dBuV	dB/m	dBuV/m	dB	cm	deg				
4984.00	29.83	48.83	-18.28	54.00	-24.17	364	385	Average	Horizontal	DF
4984.00	54.63	64.83	-10.28	74.00	-19.37	364	385	Peak	Horizontal	
7286.00	29.87	37.52	-7.65	54.00	-24.13	100	385	Average	Horizontal	DF
7286.00	54.68	62.33	-7.65	74.00	-19.32	100	385	Peak	Horizontal	
9608.00	26.38	31.59	-5.29	54.00	-27.78	110	282	Average	Horizontal	DF
9608.00	51.18	56.39	-5.29	74.00	-22.98	110	282	Peak	Horizontal	
12818.00	26.47	27.24	-0.77	54.00	-27.53	395	196	Average	Horizontal	DF
12818.00	51.27	52.04	-0.77	74.00	-22.73	395	196	Peak	Horizontal	
14412.00	26.79	24.95	1.84	54.00	-27.21	400	244	Average	Horizontal	DF
14412.00	51.59	49.75	1.84	74.00	-22.41	400	244	Peak	Horizontal	

1	2	3	4	5	6	7				
Level	Read	Level	Factor	Limit	Over	Apos	Tpos	Remark	Pol/Phase	Note
dBuV/m	dBuV	dB/m	dBuV/m	dB	cm	deg				
4984.00	47.71	57.91	-10.28	74.00	-26.29	180	198	Peak	Vertical	
7286.00	31.45	39.18	-7.65	54.00	-22.55	189	299	Average	Vertical	DF
7286.00	56.25	63.98	-7.65	74.00	-17.75	189	299	Peak	Vertical	
9608.00	25.15	30.44	-5.29	54.00	-28.85	183	389	Average	Vertical	DF
9608.00	49.95	55.24	-5.29	74.00	-24.05	183	389	Peak	Vertical	
12818.00	28.85	28.82	-0.77	54.00	-25.95	380	238	Average	Vertical	DF
12818.00	52.85	53.62	-0.77	74.00	-21.15	380	238	Peak	Vertical	

GFSK
Middle Channel (Horizontal)
Middle Channel (Vertical)

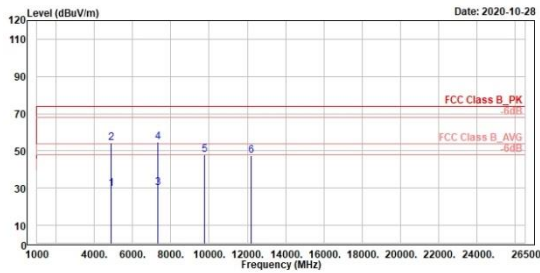

TUV Rheinland Taiwan Ltd.
 No. 458-18, Sec. 2, Fenliao, Linkou Dist., New Taipei City 244, Taiwan(R.O.C.)
 Tel: +886-2172-1000 Fax: +886-2172-1322



Peak	Freq	Level	Read Level	Factor	Limit Line	Over Limit	APos	TPos	Remark	Pol/Phase	Note
	MHz	dBuV/m	dBuV	dB/m	dBuV/m	dB	cm	deg			
1	4882.00	29.70	39.76	-10.06	54.00	-24.30	100	387	Average	Horizontal	DF
2	4882.00	54.50	64.56	-10.06	74.00	-19.50	100	387	Peak	Horizontal	
3	7323.00	29.90	37.69	-7.79	54.00	-24.10	311	263	Average	Horizontal	DF
4	7323.00	54.70	62.49	-7.79	74.00	-19.30	311	263	Peak	Horizontal	
5	9764.00	48.00	52.96	-4.96	74.00	-26.00	100	198	Peak	Horizontal	
6	12285.00	47.55	47.98	-0.43	74.00	-26.45	200	195	Peak	Horizontal	

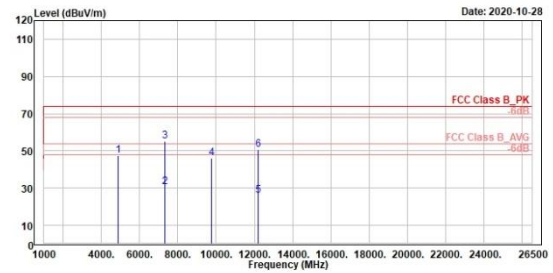

TUV Rheinland Taiwan Ltd.
 No. 458-18, Sec. 2, Fenliao, Linkou Dist., New Taipei City 244, Taiwan(R.O.C.)
 Tel: +886-2172-1000 Fax: +886-2172-1322



Peak	Freq	Level	Read Level	Factor	Limit Line	Over Limit	APos	TPos	Remark	Pol/Phase	Note
	MHz	dBuV/m	dBuV	dB/m	dBuV/m	dB	cm	deg			
1	4882.00	47.42	57.48	-10.06	74.00	-26.58	100	172	Peak	Vertical	
2	7323.00	30.61	38.40	-7.79	54.00	-23.39	105	297	Average	Vertical	DF
3	7323.00	55.41	63.20	-7.79	74.00	-18.59	105	297	Peak	Vertical	
4	9764.00	46.27	51.23	-4.96	74.00	-27.73	200	213	Peak	Vertical	
5	12285.00	25.95	26.38	-0.43	54.00	-28.05	300	231	Average	Vertical	DF
6	12285.00	50.75	51.18	-0.43	74.00	-23.25	300	231	Peak	Vertical	

GFSK

High Channel (Horizontal)

High Channel (Vertical)



TUV Rheinland Taiwan Ltd.
No. 458-18, Sec. 2, Fenhiao, Linkou Dist., New Taipei City 244, Taiwan(R.O.C.)
Tel: +886-2172-1000 Fax: +886-2172-1322

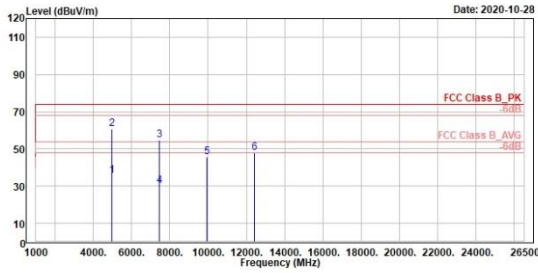

1	2	3	4	5	6
4968.00	4968.00	7448.00	7448.00	9928.00	12488.00
35.70	68.50	54.93	38.08	45.84	47.75
45.46	70.26	62.65	37.80	50.52	47.92
-9.76	-9.76	-7.72	-7.72	-4.68	-0.17
54.00	74.00	74.00	74.00	74.00	74.00
-18.38	-13.50	-19.07	-43.92	-28.16	-26.25
380	380	382	382	280	280
297 Average	297 Peak	265 Peak	265 Peak	183 Peak	177 Peak
Horizontal	Horizontal	Horizontal	Horizontal	Horizontal	Horizontal
DF			DF		



TUV Rheinland Taiwan Ltd.
No. 458-18, Sec. 2, Fenhiao, Linkou Dist., New Taipei City 244, Taiwan(R.O.C.)
Tel: +886-2172-1000 Fax: +886-2172-1322

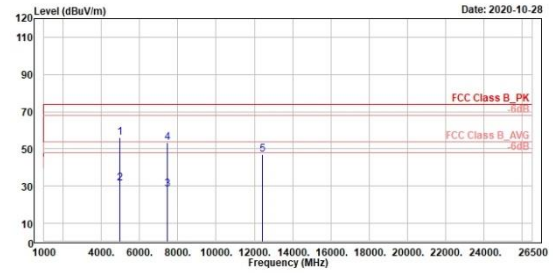

1	2	3	4	5
4968.00	4968.00	7448.00	7448.00	12488.00
56.29	31.49	28.46	53.26	47.22
66.85	41.25	36.18	60.98	47.39
-9.76	-9.76	-7.72	-7.72	-0.17
74.00	74.00	54.00	74.00	74.00
-17.71	-42.51	-25.54	-20.74	-26.78
380	380	180	180	180
178 Peak	178 Peak	302 Average	302 Peak	316 Peak
Vertical	Vertical	Vertical	Vertical	Vertical
	DF			

8DPSK

Low Channel (Horizontal)

Low Channel (Vertical)



TUV Rheinland Taiwan Ltd.
No. 458-18, Sec. 2, Fenliao, Linkou Dist., New Taipei City 244, Taiwan(R.O.C.)
Tel: +886-2172-1000 Fax: +886-2172-1322

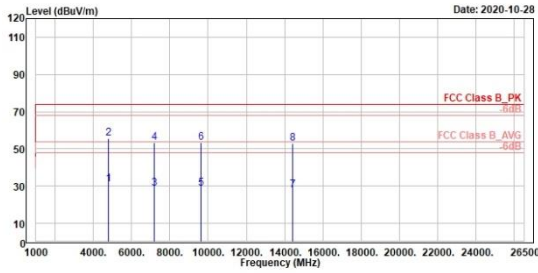

1	2	3	4	5	6	7	8
4894.00	4894.00	7206.00	7206.00	9608.00	9608.00	14412.00	14412.00
31.02	55.82	28.72	53.53	28.72	53.52	27.94	52.74
41.22	66.02	36.37	61.18	34.01	58.31	26.10	50.90
-10.20	-10.20	-7.65	-7.65	-5.29	-5.29	1.84	1.84
54.00	74.00	54.00	74.00	54.00	74.00	54.00	74.00
-22.98	-18.18	-25.28	-20.47	-25.28	-20.48	-26.06	-21.26
116	116	100	100	100	100	400	400
304	304	296	296	203	203	227	227
Average	Peak	Average	Peak	Average	Peak	Average	Peak
Horizontal	Horizontal	Horizontal	Horizontal	Horizontal	Horizontal	Horizontal	Horizontal
DF		DF		DF		DF	



TUV Rheinland Taiwan Ltd.
No. 458-18, Sec. 2, Fenliao, Linkou Dist., New Taipei City 244, Taiwan(R.O.C.)
Tel: +886-2172-1000 Fax: +886-2172-1322

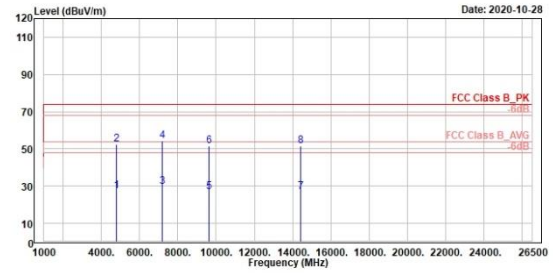

1	2	3	4	5	6	7	8
4894.00	4894.00	7206.00	7206.00	9608.00	9608.00	14412.00	14412.00
27.45	52.25	29.60	54.40	26.82	51.62	26.96	51.76
37.65	62.45	37.25	62.05	32.11	56.91	25.12	49.92
-10.20	-10.20	-7.65	-7.65	-5.29	-5.29	1.84	1.84
54.00	74.00	54.00	74.00	54.00	74.00	54.00	74.00
-26.55	-21.75	-24.40	-19.60	-27.18	-22.38	-27.04	-22.24
110	110	110	110	225	225	186	186
192	192	294	294	214	214	304	304
Average	Peak	Average	Peak	Average	Peak	Average	Peak
Vertical	Vertical	Vertical	Vertical	Vertical	Vertical	Vertical	Vertical
DF		DF		DF		DF	

8DPSK

Middle Channel (Horizontal)

Middle Channel (Vertical)



TÜV Rheinland Taiwan Ltd.
 No. 458-18, Sec. 2, Fenliao, Linkou Dist., New Taipei City 244, Taiwan(R.O.C.)
 Tel: +886-2172-1000 Fax: +886-2172-1322

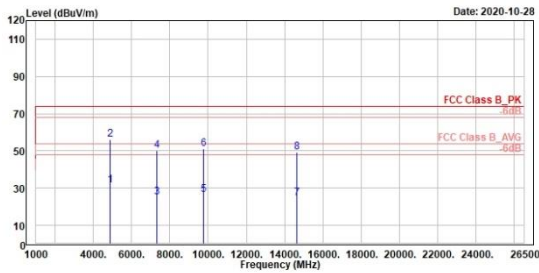

1	2	3	4	5	6	7	8
1	2	3	4	5	6	7	8
1	2	3	4	5	6	7	8
4882.00	31.34	41.40	-10.06	54.00	-22.66	100	287 Average
4882.00	56.14	66.20	-10.06	74.00	-17.86	100	287 Peak
7323.00	25.26	33.05	-7.79	54.00	-28.74	100	315 Average
7323.00	50.05	57.84	-7.79	74.00	-23.95	100	315 Peak
9764.00	26.41	31.37	-4.96	54.00	-27.59	200	193 Average
9764.00	51.28	56.16	-4.96	74.00	-22.88	200	193 Peak
14646.00	24.63	22.15	2.48	54.00	-29.37	200	259 Average
14646.00	49.43	46.95	2.48	74.00	-24.57	200	259 Peak



TÜV Rheinland Taiwan Ltd.
 No. 458-18, Sec. 2, Fenliao, Linkou Dist., New Taipei City 244, Taiwan(R.O.C.)
 Tel: +886-2172-1000 Fax: +886-2172-1322

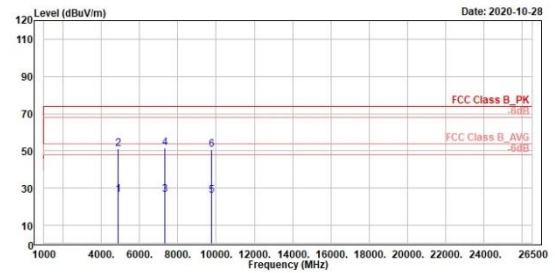

1	2	3	4	5	6
1	2	3	4	5	6
1	2	3	4	5	6
4882.00	26.54	36.60	-10.06	54.00	-27.46
4882.00	51.33	61.39	-10.06	74.00	-22.67
7323.00	26.62	34.41	-7.79	54.00	-27.38
7323.00	51.41	59.20	-7.79	74.00	-22.59
9764.00	25.88	30.84	-4.96	54.00	-28.12
9764.00	50.67	55.63	-4.96	74.00	-23.33

8DPSK
High Channel (Horizontal)
High Channel (Vertical)

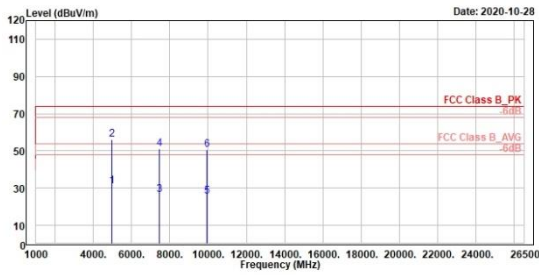

TÜV Rheinland Taiwan Ltd.
 No. 458-18, Sec. 2, Fenliao, Linkou Dist., New Taipei City 244, Taiwan(R.O.C.)
 Tel: +886-2172-1000 Fax: +886-2172-1322



1	2	3	4	5	6
Level	Read Level	Factor	Limit	Over	Apos
dBuV/m	dBuV	dB/m	dBuV/m	dB	cm
31.12	48.88	-9.76	54.00	-22.88	300
55.93	65.69	-9.76	74.00	-18.07	300
26.30	34.02	-7.72	54.00	-27.70	200
51.11	58.83	-7.72	74.00	-22.89	200
25.63	30.31	-4.68	54.00	-28.37	100
50.43	55.11	-4.68	74.00	-23.57	100

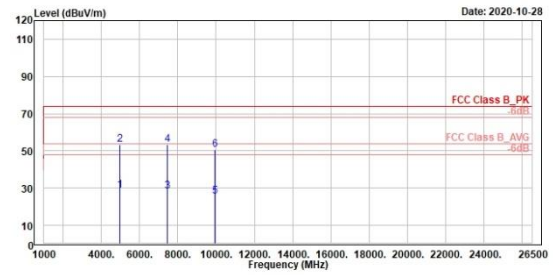

TÜV Rheinland Taiwan Ltd.
 No. 458-18, Sec. 2, Fenliao, Linkou Dist., New Taipei City 244, Taiwan(R.O.C.)
 Tel: +886-2172-1000 Fax: +886-2172-1322



1	2	3	4	5	6
Level	Read Level	Factor	Limit	Over	Apos
dBuV/m	dBuV	dB/m	dBuV/m	dB	cm
28.54	38.30	-9.76	54.00	-25.46	296
53.34	63.10	-9.76	74.00	-20.66	296
28.51	36.23	-7.72	54.00	-25.49	299
53.31	61.03	-7.72	74.00	-20.69	299
25.65	30.33	-4.68	54.00	-28.35	300
50.45	55.13	-4.68	74.00	-23.55	300

Mains Conducted Emission, 150kHz ~ 30MHz

Worst Band

(Line)

(Neutral)



TUV Rheinland Taiwan Ltd(New Taipei City Branch).
No. 458-19, Sec. 2, Fenliao Rd., Linkou Dist., New Taipei City 244
Tel:+886-2172-1000 Fax:+886-2172-1322



TUV Rheinland Taiwan Ltd(New Taipei City Branch).
No. 458-19, Sec. 2, Fenliao Rd., Linkou Dist., New Taipei City 244
Tel:+886-2172-1000 Fax:+886-2172-1322

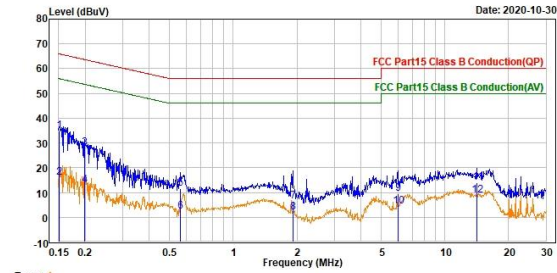
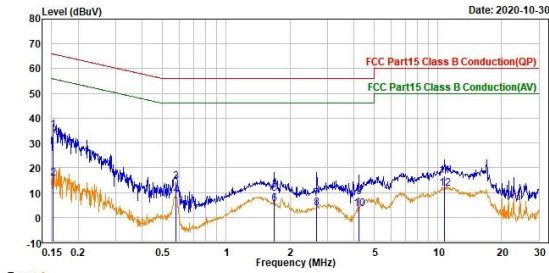

Trace: 1

	Read Freq	Level	Factor	Level	Limit	Over	Remark	Pol/Phase	Note
	MHz	dBuV	dB	dBuV	dBuV	dB			
1	0.152	35.14	0.05	35.19	65.92	-30.73	QP	line1	
2	0.152	15.77	0.05	15.82	55.92	-40.10	Average	line1	
3	0.576	14.19	0.06	14.25	56.00	-41.75	QP	line1	
4	0.576	8.69	0.06	8.75	46.00	-37.25	Average	line1	
5	1.682	9.34	0.11	9.45	56.00	-46.55	QP	line1	
6	1.682	5.21	0.11	5.32	46.00	-40.68	Average	line1	
7	2.675	7.21	0.12	7.33	56.00	-48.67	QP	line1	
8	2.675	3.70	0.12	3.82	46.00	-42.18	Average	line1	
9	4.231	8.08	0.16	8.24	56.00	-47.76	QP	line1	
10	4.231	3.04	0.16	3.20	46.00	-42.80	Average	line1	
11	10.745	16.32	0.31	16.63	60.00	-43.37	QP	line1	
12	10.745	11.39	0.31	11.70	50.00	-38.30	Average	line1	

Trace: 1

	Read Freq	Level	Factor	Level	Limit	Over	Remark	Pol/Phase	Note
	MHz	dBuV	dB	dBuV	dBuV	dB			
1	0.151	34.65	0.05	34.70	65.96	-31.26	QP	neutral	
2	0.151	16.04	0.05	16.09	55.96	-39.87	Average	neutral	
3	0.198	28.01	0.05	28.06	63.68	-35.62	QP	neutral	
4	0.198	12.81	0.05	12.86	53.68	-40.82	Average	neutral	
5	0.562	11.61	0.06	11.67	56.00	-44.33	QP	neutral	
6	0.562	2.30	0.06	2.36	46.00	-43.64	Average	neutral	
7	1.915	6.27	0.10	6.37	56.00	-49.63	QP	neutral	
8	1.915	1.85	0.10	1.95	46.00	-44.05	Average	neutral	
9	5.997	9.19	0.20	9.39	60.00	-50.61	QP	neutral	
10	5.997	4.05	0.20	4.25	50.00	-45.75	Average	neutral	
11	14.204	13.42	0.40	13.82	60.00	-46.18	QP	neutral	
12	14.204	8.54	0.40	8.94	50.00	-41.06	Average	neutral	