



FCC Radio Test Report

FCC ID: 2APRGMS30

This report concerns: **Original Grant**

Project No. : 2403G073
Equipment : AX3000 Whole-Home Wi-Fi 6 Mesh System with 2.5G Port
Brand Name : Cudy
Test Model : M3000
Series Model : N/A
Applicant : Shenzhen Cudy Technology Co., Ltd.
Address : Room A606, Gaoxinqi Industrial Park, Liuxianyi Road, Baoan District, Shenzhen, China
Manufacturer : Shenzhen Cudy Technology Co., Ltd.
Address : Room A606, Gaoxinqi Industrial Park, Liuxianyi Road, Baoan District, Shenzhen, China
Factory : Shenzhen Cudy Technology Co., Ltd.
Address : Room A606, Gaoxinqi Industrial Park, Liuxianyi Road, Baoan District, Shenzhen, China
Date of Receipt : Mar. 14, 2024
Date of Test : Mar. 19, 2024 ~ May 29, 2024
Issued Date : Jun. 19, 2024
Report Version : R01
Test Sample : Engineering Sample No.: SSL2024031413 for radiated and ac power line conducted emissions, SSL2024031414 for others.
Standard(s) : FCC CFR Title 47, Part 15, Subpart E

The above equipment has been tested and found compliance with the requirement of the relative standards by BTL Inc.

Prepared by : Sheldon Ou
Sheldon Ou

Approved by : Chay Cai
Chay Cai

Room 108, Building 2, No.1, Yile Road, Songshan Lake Zone, Dongguan City, Guangdong, People's Republic of China.

Tel: +86-769-8318-3000 Web: www.newbtl.com Service mail: btl_qa@newbtl.com

Declaration

BTL represents to the client that testing is done in accordance with standard procedures as applicable and that test instruments used has been calibrated with standards traceable to international standard(s) and/or national standard(s).

BTL's reports apply only to the specific samples tested under conditions. It is manufacture's responsibility to ensure that additional production units of this model are manufactured with the identical electrical and mechanical components. **BTL** assumes no responsibility for the data provided by the customer, any statements, inferences or generalizations drawn by the customer or others from the reports issued by **BTL**. The report must not be used by the client to claim product certification, approval, or endorsement by A2LA or any agency of the U.S. Government.

This report is the confidential property of the client. As a mutual protection to the clients, the public and ourselves, the test report shall not be reproduced, except in full, without our written approval.

BTL's laboratory quality assurance procedures are in compliance with the ISO/IEC 17025: 2017 requirements, and accredited by the conformity assessment authorities listed in this test report.

BTL is not responsible for the sampling stage, so the results only apply to the sample as received.

The information, data and test plan are provided by manufacturer which may affect the validity of results, so it is manufacturer's responsibility to ensure that the apparatus meets the essential requirements of applied standards and in all the possible configurations as representative of its intended use.

Limitation

For the use of the authority's logo is limited unless the Test Standard(s)/Scope(s)/Item(s) mentioned in this test report is (are) included in the conformity assessment authorities acceptance respective.

Please note that the measurement uncertainty is provided for informational purpose only and are not use in determining the Pass/Fail results.

Table of Contents	Page
REPORT ISSUED HISTORY	6
1 . APPLICABLE STANDARDS	7
2 . SUMMARY OF TEST RESULTS	7
2.1 TEST FACILITY	8
2.2 MEASUREMENT UNCERTAINTY	8
2.3 TEST ENVIRONMENT CONDITIONS	9
3 . GENERAL INFORMATION	10
3.1 GENERAL DESCRIPTION OF EUT	10
3.2 TEST MODES	13
3.3 PARAMETERS OF TEST SOFTWARE	19
3.4 DUTY CYCLE	23
3.5 BLOCK DIAGRAM SHOWING THE CONFIGURATION OF SYSTEM TESTED	26
3.6 SUPPORT UNITS	26
3.7 CUSTOMER INFORMATION DESCRIPTION	26
4 . AC POWER LINE CONDUCTED EMISSIONS	27
4.1 LIMIT	27
4.2 TEST PROCEDURE	27
4.3 DEVIATION FROM TEST STANDARD	27
4.4 TEST SETUP	28
4.5 EUT OPERATION CONDITIONS	28
4.6 TEST RESULTS	28
5 . RADIATED EMISSIONS	29
5.1 LIMIT	29
5.2 TEST PROCEDURE	30
5.3 DEVIATION FROM TEST STANDARD	31
5.4 TEST SETUP	31
5.5 EUT OPERATION CONDITIONS	33
5.6 TEST RESULTS - 9 KHZ TO 30 MHZ	33
5.7 TEST RESULTS - 30 MHZ TO 1000 MHZ	33
5.8 TEST RESULTS - ABOVE 1000 MHZ	33
6 . BANDWIDTH	34
6.1 LIMIT	34
6.2 TEST PROCEDURE	34

Table of Contents	Page
6.3 DEVIATION FROM STANDARD	34
6.4 TEST SETUP	35
6.5 EUT OPERATION CONDITIONS	35
6.6 TEST RESULTS	35
7 . MAXIMUM OUTPUT POWER	36
7.1 LIMIT	36
7.2 TEST PROCEDURE	36
7.3 DEVIATION FROM STANDARD	36
7.4 TEST SETUP	36
7.5 EUT OPERATION CONDITIONS	36
7.6 TEST RESULTS	36
8 . POWER SPECTRAL DENSITY	37
8.1 LIMIT	37
8.2 TEST PROCEDURE	37
8.3 DEVIATION FROM STANDARD	37
8.4 TEST SETUP	38
8.5 EUT OPERATION CONDITIONS	38
8.6 TEST RESULTS	38
9 . FREQUENCY STABILITY	39
9.1 LIMIT	39
9.2 TEST PROCEDURE	39
9.3 DEVIATION FROM STANDARD	39
9.4 TEST SETUP	39
9.5 EUT OPERATION CONDITIONS	39
9.6 TEST RESULTS	39
10 . MEASUREMENT INSTRUMENTS LIST	40
11 . EUT TEST PHOTOS	43
APPENDIX A - AC POWER LINE CONDUCTED EMISSIONS	49
APPENDIX B - RADIATED EMISSION - 9 KHZ TO 30 MHZ	52
APPENDIX C - RADIATED EMISSION - 30 MHZ TO 1000 MHZ	57
APPENDIX D - RADIATED EMISSION - ABOVE 1000 MHZ	60
APPENDIX E - BANDWIDTH	177
APPENDIX F - MAXIMUM OUTPUT POWER	208

Table of Contents	Page
APPENDIX G - POWER SPECTRAL DENSITY	265
APPENDIX H - FREQUENCY STABILITY	326

REPORT ISSUED HISTORY

Report No.	Version	Description	Issued Date	Note
BTL-FCCP-2-2403G073	R00	Original Report.	Jun. 06, 2024	Invalid
BTL-FCCP-2-2403G073	R01	Modified the comments of Timco.	Jun. 19, 2024	Valid

1. APPLICABLE STANDARDS

According to the specifications of the manufacturer, the EUT must comply with the requirements of the following standards:

ANSI C63.10-2013

The following reference test guidance is not within the scope of accreditation of A2LA:

KDB 789033 D02 General UNII Test Procedures New Rules v02r01

KDB 662911 D01 Multiple Transmitter Output v02r01

2. SUMMARY OF TEST RESULTS

Test procedures according to the technical standard(s):

FCC CFR Title 47, Part 15, Subpart E				
Standard(s) Section	Test Item	Test Result	Judgment	Remark
15.207 15.407(b)	AC Power Line Conducted Emissions	APPENDIX A	PASS	-----
15.407(b) 15.205(a) 15.209(a)	Radiated Emissions	APPENDIX B APPENDIX C APPENDIX D	PASS	-----
15.407(a) 15.407(e)	Bandwidth	APPENDIX E	PASS	-----
15.407(a)	Maximum Output Power	APPENDIX F	PASS	-----
15.407(a)	Power Spectral Density	APPENDIX G	PASS	-----
15.407(g)	Frequency Stability	APPENDIX H	PASS	-----
15.203	Antenna Requirements	-----	PASS	NOTE (2)
15.407(c)	Automatically Discontinue Transmission	-----	PASS	NOTE (3)

Note:

- (1) "N/A" denotes test is not applicable in this test report.
- (2) The device what use a permanently attached antenna were considered sufficient to comply with the provisions of 15.203.
- (3) During no any information transmission, the EUT can automatically discontinue transmission and become standby mode for power saving. the EUT can detect the controlling signal of ACK message transmitting from remote device and verify whether it shall resend or discontinue transmission.
- (4) For UNII-1 this device was functioned as a
 - Outdoor access point device
 - Indoor access point device
 - Fixed point-to-point access points device
 - Client device

2.1 TEST FACILITY

The test facilities used to collect the test data in this report:

For Output Power item: Room 108, Building 2, No.1, Yile Road, Songshan Lake Zone, Dongguan City, Guangdong, People's Republic of China.

For other items: No.3, Jinshagang 1st Road, Dalang, Dongguan City, Guangdong, People's Republic of China.

BTL's Registration Number for FCC: 747969

BTL's Designation Number for FCC: CN1377

2.2 MEASUREMENT UNCERTAINTY

ISO/IEC 17025 requires that an estimate of the measurement uncertainties associated with the emissions test results be included in the report. The measurement uncertainties given below are based on a 95% confidence level (based on a coverage factor (k=2))

The BTL measurement uncertainty as below table:

A. AC power line conducted emissions test:

Test Site	Method	Measurement Frequency Range	U,(dB)
DG-C02	CISPR	150kHz ~ 30MHz	2.88

B. Radiated emissions test:

Test Site	Method	Measurement Frequency Range	U,(dB)
DG-CB01	CISPR	9kHz ~ 30MHz	2.36

Test Site	Method	Measurement Frequency Range	Ant. H / V	U,(dB)
DG-CB03 (3m)	CISPR	30MHz ~ 200MHz	V	4.40
		30MHz ~ 200MHz	H	3.62
		200MHz ~ 1,000MHz	V	4.58
		200MHz ~ 1,000MHz	H	3.98

Test Site	Method	Measurement Frequency Range	U,(dB)
DG-CB03 (3m)	CISPR	1GHz ~ 6GHz	4.08
		6GHz ~ 18GHz	4.62

Test Site	Method	Measurement Frequency Range	U,(dB)
DG-CB03 (1m)	CISPR	18 ~ 26.5 GHz	3.36
		26.5 ~ 40 GHz	3.58

C. Other Measurement test:

Test Item	Uncertainty
Bandwidth	0.90 %
Maximum Output Power	0.95 dB
Power Spectral Density	1.4 dB
Frequency Stability	2.7 ppm
Temperature	0.8 °C
Humidity	2.2 %

Note: Unless specifically mentioned, the uncertainty of measurement has not been taken into account to declare the compliance or non-compliance to the specification.

2.3 TEST ENVIRONMENT CONDITIONS

Test Item	Temperature	Humidity	Test Voltage	Tested By	Test Date
AC Power Line Conducted Emissions	25°C	66%	AC 120V/60Hz	Hayden Chen	Apr. 08, 2024
Radiated Emissions -9kHz to 30MHz	24°C	56%	AC 120V/60Hz	Hayden Chen	May 16, 2024
Radiated Emissions -30MHz to 1000MHz	23°C	44%	AC 120V/60Hz	Jensen Zhou	Mar, 26, 2024
Radiated Emissions -Above 1000 MHz	25°C	48-50%	AC 120V/60Hz	Jensen Zhou Allen Tong	Apr. 03, 2024- Apr. 07, 2024
Bandwidth	23°C	59%	DC 12V	Parker Yang	Apr. 20, 2024
Maximum Output Power	23-24°C	49-52%	DC 12V	Evan Fang	Apr. 01, 2024- May 27, 2024
Power Spectral Density	24°C	57%	DC 12V	Parker Yang Hayden Chen	Apr. 19, 2024
Frequency Stability	Normal & Extreme	59%	Normal & Extreme	Parker Yang	Apr. 20, 2024

3. GENERAL INFORMATION

3.1 GENERAL DESCRIPTION OF EUT

Equipment	AX3000 Whole-Home Wi-Fi 6 Mesh System with 2.5G Port
Brand Name	Cudy
Test Model	M3000
Series Model	N/A
Model Difference(s)	N/A
Software Version	2.0.0
Hardware Version	V2
Power Source	DC Voltage supplied from AC adapter. Model: DSA-12PF11-12 FUS 120100
Power Rating	I/P:100-240V ~ 50/60Hz 0.5A O/P:+12.0V --- 1.0A
Operation Frequency Band(s)	UNII-1: 5150 MHz ~ 5250 MHz UNII-2A: 5250 MHz ~ 5350 MHz UNII-2C: 5470 MHz ~ 5600 MHz & 5650 MHz ~5725 MHz UNII-3: 5725 MHz ~ 5850 MHz
Modulation Type	IEEE 802.11a/n/ac: OFDM IEEE 802.11ax: OFDMA
Bit Rate of Transmitter	IEEE 802.11a: 54/48/36/24/18/12/9/6 Mbps IEEE 802.11n: up to 300 Mbps IEEE 802.11ac: up to 1733.4 Mbps IEEE 802.11ax: up to 2402 Mbps
Maximum Output Power UNII-1 Non Beamforming	IEEE 802.11ax(HE40): 25.66 dBm (0.3681 W)
Maximum Output Power UNII-2A Non Beamforming	IEEE 802.11ac(VHT80): 19.64 dBm (0.0920 W)
Maximum Output Power UNII-2C Non Beamforming	IEEE 802.11ac(VHT40): 19.58 dBm (0.0908 W)
Maximum Output Power UNII-3 Non Beamforming	IEEE 802.11ax(HE80): 25.66 dBm (0.3681 W)
Maximum Output Power UNII-1 Beamforming	IEEE 802.11ax(HE40): 25.32 dBm (0.3404 W)
Maximum Output Power UNII-2A Beamforming	IEEE 802.11ax(HE40): 19.19 dBm (0.0830 W)
Maximum Output Power UNII-2C Beamforming	IEEE 802.11ac(VHT40): 19.34 dBm (0.0859 W)
Maximum Output Power UNII-3 Beamforming	IEEE 802.11ac(VHT40): 25.37 dBm (0.3443 W)

Note:

1. For a more detailed features description, please refer to the manufacturer's specifications or the user's manual.

2. Channel List:

IEEE 802.11a IEEE 802.11n(HT20) IEEE 802.11ac(VHT20) IEEE 802.11ax(HE20)		IEEE 802.11n(HT40) IEEE 802.11ac(VHT40) IEEE 802.11ax(HE40)		IEEE 802.11ac(VHT80) IEEE 802.11ax(HE80)	
UNII-1		UNII-1		UNII-1	
Channel	Frequency (MHz)	Channel	Frequency (MHz)	Channel	Frequency (MHz)
36	5180	38	5190	42	5210
40	5200	46	5230		
44	5220				
48	5240				



IEEE 802.11a IEEE 802.11n(HT20) IEEE 802.11ac(VHT20) IEEE 802.11ax(HE20)		IEEE 802.11n(HT40) IEEE 802.11ac(VHT40) IEEE 802.11ax(HE40)		IEEE 802.11ac(VHT80) IEEE 802.11ax(HE80)	
UNII-2A		UNII-2A		UNII-2A	
Channel	Frequency (MHz)	Channel	Frequency (MHz)	Channel	Frequency (MHz)
52	5260	54	5270	58	5290
56	5280	62	5310		
60	5300				
64	5320				

IEEE 802.11a IEEE 802.11n(HT20) IEEE 802.11ac(VHT20) IEEE 802.11ax(HE20)		IEEE 802.11n(HT40) IEEE 802.11ac(VHT40) IEEE 802.11ax(HE40)		IEEE 802.11ac(VHT80) IEEE 802.11ax(HE80)	
UNII-2C		UNII-2C		UNII-2C	
Channel	Frequency (MHz)	Channel	Channel	Frequency (MHz)	Channel
100	5500	102	5510	106	5530
104	5520	110	5550		
108	5540	134	5670		
112	5560				
116	5580				
132	5660				
136	5680				
140	5700				

IEEE 802.11a IEEE 802.11n(HT20) IEEE 802.11ac(VHT20) IEEE 802.11ax(HE20)		IEEE 802.11n(HT40) IEEE 802.11ac(VHT40) IEEE 802.11ax(HE40)		IEEE 802.11ac(VHT80) IEEE 802.11ax(HE80)	
UNII-3		UNII-3		UNII-3	
Channel	Frequency (MHz)	Channel	Frequency (MHz)	Channel	Frequency (MHz)
149	5745	151	5755	155	5775
153	5765	159	5795		
157	5785				
161	5805				
165	5825				

IEEE 802.11ac(VHT160) IEEE 802.11ax(HE160)	
Channel	Frequency (MHz)
50	5250

3. Antenna Specification:

Ant.	Brand	P/N	Antenna Type	Connector	Gain (dBi)
1	 South star	3.N101.1078	PCB	N/A	5.55
2	 South star	3.N101.1078	PCB	N/A	5.55
3	 South star	3.N101.1078	PCB	N/A	5.55

Note:

- 1) This EUT supports MIMO 3X3, any transmit signals are correlated with each other, so Directional gain= $G_{ANT}+10\log(N)$ dBi, that is Directional gain= $5.55+10\log(3)$ dBi=10.32. So, the UNII-1, UNII-3 output power limit is $30-(10.32-6)=25.68$, the UNII-2A, UNII-2C output power limit is $23.98-(10.32-6)=19.66$. The UNII-1 power spectral density limit is $17-(10.32-6)=12.68$, the UNII-2A, UNII-2C power spectral density limit is $11-(10.32-6)=6.68$, the UNII-3 power spectral density limit is $30-(10.32-6)=25.68$.
- 2) Beamforming Gain: 4.77 dB, that is Directional gain= $4.77+5.55=10.32$. So, the UNII-1 and UNII-3 output power limit is $30-(10.32-6)=25.68$. the UNII-2A, UNII-2C output power limit is $23.98-(10.32-6)=19.66$.

4. Table for Antenna Configuration:

For Non Beamforming:

Operating Mode	TX Mode	3TX
IEEE 802.11a		V (Ant. 1 + Ant. 2 + Ant. 3)
IEEE 802.11n(HT20)		V (Ant. 1 + Ant. 2 + Ant. 3)
IEEE 802.11n(HT40)		V (Ant. 1 + Ant. 2 + Ant. 3)
IEEE 802.11ac(VHT20)		V (Ant. 1 + Ant. 2 + Ant. 3)
IEEE 802.11ac(VHT40)		V (Ant. 1 + Ant. 2 + Ant. 3)
IEEE 802.11ac(VHT80)		V (Ant. 1 + Ant. 2 + Ant. 3)
IEEE 802.11ac(VHT160)		V (Ant. 1 + Ant. 2 + Ant. 3)
IEEE 802.11ax(HE20)		V (Ant. 1 + Ant. 2 + Ant. 3)
IEEE 802.11ax(HE40)		V (Ant. 1 + Ant. 2 + Ant. 3)
IEEE 802.11ax(HE80)		V (Ant. 1 + Ant. 2 + Ant. 3)
IEEE 802.11ax(HE160)		V (Ant. 1 + Ant. 2 + Ant. 3)

For Beamforming:

Operating Mode	TX Mode	3TX
IEEE 802.11n(HT20)		V (Ant. 1 + Ant. 2 + Ant. 3)
IEEE 802.11n(HT40)		V (Ant. 1 + Ant. 2 + Ant. 3)
IEEE 802.11ac(VHT20)		V (Ant. 1 + Ant. 2 + Ant. 3)
IEEE 802.11ac(VHT40)		V (Ant. 1 + Ant. 2 + Ant. 3)
IEEE 802.11ac(VHT80)		V (Ant. 1 + Ant. 2 + Ant. 3)
IEEE 802.11ac(VHT160)		V (Ant. 1 + Ant. 2 + Ant. 3)
IEEE 802.11ax(HE20)		V (Ant. 1 + Ant. 2 + Ant. 3)
IEEE 802.11ax(HE40)		V (Ant. 1 + Ant. 2 + Ant. 3)
IEEE 802.11ax(HE80)		V (Ant. 1 + Ant. 2 + Ant. 3)
IEEE 802.11ax(HE160)		V (Ant. 1 + Ant. 2 + Ant. 3)

3.2 TEST MODES

The test system was pre-tested based on the consideration of all possible combinations of EUT operation mode.

Pretest Mode	Description
Mode 1	TX A Mode Channel 36/40/48 (UNII-1)
Mode 2	TX AC(VHT20) Mode Channel 36/40/48 (UNII-1)
Mode 3	TX AC(VHT40) Mode Channel 38/46 (UNII-1)
Mode 4	TX AC(VHT80) Mode Channel 42 (UNII-1)
Mode 5	TX AX(HE20) Mode Channel 36/40/48 (UNII-1)
Mode 6	TX AX(HE40) Mode Channel 38/46 (UNII-1)
Mode 7	TX AX(HE80) Mode Channel 42 (UNII-1)
Mode 8	TX A Mode Channel 52/60/64 (UNII-2A)
Mode 9	TX AC(VHT20) Mode Channel 52/60/64 (UNII-2A)
Mode 10	TX AC(VHT40) Mode Channel 54/62 (UNII-2A)
Mode 11	TX AC(VHT80) Mode Channel 58 (UNII-2A)
Mode 12	TX AX(HE20) Mode Channel 52/60/64 (UNII-2A)
Mode 13	TX AX(HE40) Mode Channel 54/62 (UNII-2A)
Mode 14	TX AX(HE80) Mode Channel 58 (UNII-2A)
Mode 15	TX AC(VHT160) Mode Channel 50 (UNII-1+UNII-2A)
Mode 16	TX AX(HE160) Mode Channel 50 (UNII-1+UNII-2A)
Mode 17	TX A Mode Channel 100/116/140 (UNII-2C)
Mode 18	TX AC(VHT20) Mode Channel 100/116/140 (UNII-2C)
Mode 19	TX AC(VHT40) Mode Channel 102/110/134 (UNII-2C)
Mode 20	TX AC(VHT80) Mode Channel 106 (UNII-2C)
Mode 21	TX AX(HE20) Mode Channel 100/116/140 (UNII-2C)
Mode 22	TX AX(HE40) Mode Channel 102/110/134 (UNII-2C)
Mode 23	TX AX(HE80) Mode Channel 106 (UNII-2C)
Mode 24	TX A Mode Channel 149/157/165 (UNII-3)
Mode 25	TX AC(VHT20) Mode Channel 149/157/165 (UNII-3)
Mode 26	TX AC(VHT40) Mode Channel 151/159 (UNII-3)
Mode 27	TX AC(VHT80) Mode Channel 155 (UNII-3)
Mode 28	TX AX(HE20) Mode Channel 149/157/165 (UNII-3)
Mode 29	TX AX(HE40) Mode Channel 151/159 (UNII-3)
Mode 30	TX AX(HE80) Mode Channel 155 (UNII-3)
Mode 31	TX AX(HE40) Mode Channel 38 (UNII-1)

Following mode(s) was (were) found to be the worst case(s) and selected for the final test.

AC power line conducted emissions test	
Final Test Mode	Description
Mode 31	TX AX(HE40) Mode Channel 38 (UNII-1)

Radiated Emissions Test - Below 1GHz	
Final Test Mode	Description
Mode 31	TX AX(HE40) Mode Channel 38 (UNII-1)

Radiated Emissions Test - Above 1GHz_Non Beamforming	
Final Test Mode	Description
Mode 1	TX A Mode Channel 36/40/48 (UNII-1)
Mode 2	TX AC(VHT20) Mode Channel 36/40/48 (UNII-1)
Mode 3	TX AC(VHT40) Mode Channel 38/46 (UNII-1)
Mode 4	TX AC(VHT80) Mode Channel 42 (UNII-1)
Mode 5	TX AX(HE20) Mode Channel 36/40/48 (UNII-1)
Mode 6	TX AX(HE40) Mode Channel 38/46 (UNII-1)
Mode 7	TX AX(HE80) Mode Channel 42 (UNII-1)
Mode 8	TX A Mode Channel 52/60/64 (UNII-2A)
Mode 9	TX AC(VHT20) Mode Channel 52/60/64 (UNII-2A)
Mode 10	TX AC(VHT40) Mode Channel 54/62 (UNII-2A)
Mode 11	TX AC(VHT80) Mode Channel 58 (UNII-2A)
Mode 12	TX AX(HE20) Mode Channel 52/60/64 (UNII-2A)
Mode 13	TX AX(HE40) Mode Channel 54/62 (UNII-2A)
Mode 14	TX AX(HE80) Mode Channel 58 (UNII-2A)
Mode 15	TX AC(VHT160) Mode Channel 50 (UNII-1+UNII-2A)
Mode 16	TX AX(HE160) Mode Channel 50 (UNII-1+UNII-2A)
Mode 17	TX A Mode Channel 100/116/140 (UNII-2C)
Mode 18	TX AC(VHT20) Mode Channel 100/116/140 (UNII-2C)
Mode 19	TX AC(VHT40) Mode Channel 102/110/134 (UNII-2C)
Mode 20	TX AC(VHT80) Mode Channel 106 (UNII-2C)
Mode 21	TX AX(HE20) Mode Channel 100/116/140 (UNII-2C)
Mode 22	TX AX(HE40) Mode Channel 102/110/134 (UNII-2C)
Mode 23	TX AX(HE80) Mode Channel 106 (UNII-2C)
Mode 24	TX A Mode Channel 149/157/165 (UNII-3)
Mode 25	TX AC(VHT20) Mode Channel 149/157/165 (UNII-3)
Mode 26	TX AC(VHT40) Mode Channel 151/159 (UNII-3)
Mode 27	TX AC(VHT80) Mode Channel 155 (UNII-3)
Mode 28	TX AX(HE20) Mode Channel 149/157/165 (UNII-3)
Mode 29	TX AX(HE40) Mode Channel 151/159 (UNII-3)

Mode 30	TX AX(HE80) Mode Channel 155 (UNII-3)
---------	---------------------------------------

Maximum Output Power test_Non Beamforming	
Final Test Mode	Description
Mode 1	TX A Mode Channel 36/40/48 (UNII-1)
Mode 2	TX AC(VHT20) Mode Channel 36/40/48 (UNII-1)
Mode 3	TX AC(VHT40) Mode Channel 38/46 (UNII-1)
Mode 4	TX AC(VHT80) Mode Channel 42 (UNII-1)
Mode 5	TX AX(HE20) Mode Channel 36/40/48 (UNII-1)
Mode 6	TX AX(HE40) Mode Channel 38/46 (UNII-1)
Mode 7	TX AX(HE80) Mode Channel 42 (UNII-1)
Mode 8	TX A Mode Channel 52/60/64 (UNII-2A)
Mode 9	TX AC(VHT20) Mode Channel 52/60/64 (UNII-2A)
Mode 10	TX AC(VHT40) Mode Channel 54/62 (UNII-2A)
Mode 11	TX AC(VHT80) Mode Channel 58 (UNII-2A)
Mode 12	TX AX(HE20) Mode Channel 52/60/64 (UNII-2A)
Mode 13	TX AX(HE40) Mode Channel 54/62 (UNII-2A)
Mode 14	TX AX(HE80) Mode Channel 58 (UNII-2A)
Mode 15	TX AC(VHT160) Mode Channel 50 (UNII-1+UNII-2A)
Mode 16	TX AX(HE160) Mode Channel 50 (UNII-1+UNII-2A)
Mode 17	TX A Mode Channel 100/116/140 (UNII-2C)
Mode 18	TX AC(VHT20) Mode Channel 100/116/140 (UNII-2C)
Mode 19	TX AC(VHT40) Mode Channel 102/110/134 (UNII-2C)
Mode 20	TX AC(VHT80) Mode Channel 106 (UNII-2C)
Mode 21	TX AX(HE20) Mode Channel 100/116/140 (UNII-2C)
Mode 22	TX AX(HE40) Mode Channel 102/110/134 (UNII-2C)
Mode 23	TX AX(HE80) Mode Channel 106 (UNII-2C)
Mode 24	TX A Mode Channel 149/157/165 (UNII-3)
Mode 25	TX AC(VHT20) Mode Channel 149/157/165 (UNII-3)
Mode 26	TX AC(VHT40) Mode Channel 151/159 (UNII-3)
Mode 27	TX AC(VHT80) Mode Channel 155 (UNII-3)
Mode 28	TX AX(HE20) Mode Channel 149/157/165 (UNII-3)
Mode 29	TX AX(HE40) Mode Channel 151/159 (UNII-3)
Mode 30	TX AX(HE80) Mode Channel 155 (UNII-3)

Maximum Output Power test_Beamforming	
Final Test Mode	Description
Mode 2	TX AC(VHT20) Mode Channel 36/40/48 (UNII-1)
Mode 3	TX AC(VHT40) Mode Channel 38/46 (UNII-1)
Mode 4	TX AC(VHT80) Mode Channel 42 (UNII-1)
Mode 5	TX AX(HE20) Mode Channel 36/40/48 (UNII-1)
Mode 6	TX AX(HE40) Mode Channel 38/46 (UNII-1)
Mode 7	TX AX(HE80) Mode Channel 42 (UNII-1)
Mode 9	TX AC(VHT20) Mode Channel 52/60/64 (UNII-2A)
Mode 10	TX AC(VHT40) Mode Channel 54/62 (UNII-2A)
Mode 11	TX AC(VHT80) Mode Channel 58 (UNII-2A)
Mode 12	TX AX(HE20) Mode Channel 52/60/64 (UNII-2A)
Mode 13	TX AX(HE40) Mode Channel 54/62 (UNII-2A)
Mode 14	TX AX(HE80) Mode Channel 58 (UNII-2A)
Mode 15	TX AC(VHT160) Mode Channel 50 (UNII-1+UNII-2A)
Mode 16	TX AX(HE160) Mode Channel 50 (UNII-1+UNII-2A)
Mode 18	TX AC(VHT20) Mode Channel 100/116/140 (UNII-2C)
Mode 19	TX AC(VHT40) Mode Channel 102/110/134 (UNII-2C)
Mode 20	TX AC(VHT80) Mode Channel 106 (UNII-2C)
Mode 21	TX AX(HE20) Mode Channel 100/116/140 (UNII-2C)
Mode 22	TX AX(HE40) Mode Channel 102/110/134 (UNII-2C)
Mode 23	TX AX(HE80) Mode Channel 106 (UNII-2C)
Mode 25	TX AC(VHT20) Mode Channel 149/157/165 (UNII-3)
Mode 26	TX AC(VHT40) Mode Channel 151/159 (UNII-3)
Mode 27	TX AC(VHT80) Mode Channel 155 (UNII-3)
Mode 28	TX AX(HE20) Mode Channel 149/157/165 (UNII-3)
Mode 29	TX AX(HE40) Mode Channel 151/159 (UNII-3)
Mode 30	TX AX(HE80) Mode Channel 155 (UNII-3)

Other Conducted Test_Non Beamforming	
Final Test Mode	Description
Mode 1	TX A Mode Channel 36/40/48 (UNII-1)
Mode 2	TX AC(VHT20) Mode Channel 36/40/48 (UNII-1)
Mode 3	TX AC(VHT40) Mode Channel 38/46 (UNII-1)
Mode 4	TX AC(VHT80) Mode Channel 42 (UNII-1)
Mode 5	TX AX(HE20) Mode Channel 36/40/48 (UNII-1)
Mode 6	TX AX(HE40) Mode Channel 38/46 (UNII-1)
Mode 7	TX AX(HE80) Mode Channel 42 (UNII-1)
Mode 8	TX A Mode Channel 52/60/64 (UNII-2A)
Mode 9	TX AC(VHT20) Mode Channel 52/60/64 (UNII-2A)
Mode 10	TX AC(VHT40) Mode Channel 54/62 (UNII-2A)
Mode 11	TX AC(VHT80) Mode Channel 58 (UNII-2A)
Mode 12	TX AX(HE20) Mode Channel 52/60/64 (UNII-2A)
Mode 13	TX AX(HE40) Mode Channel 54/62 (UNII-2A)
Mode 14	TX AX(HE80) Mode Channel 58 (UNII-2A)
Mode 15	TX AC(VHT160) Mode Channel 50 (UNII-1+UNII-2A)
Mode 16	TX AX(HE160) Mode Channel 50 (UNII-1+UNII-2A)
Mode 17	TX A Mode Channel 100/116/140 (UNII-2C)
Mode 18	TX AC(VHT20) Mode Channel 100/116/140 (UNII-2C)
Mode 19	TX AC(VHT40) Mode Channel 102/110/134 (UNII-2C)
Mode 20	TX AC(VHT80) Mode Channel 106 (UNII-2C)
Mode 21	TX AX(HE20) Mode Channel 100/116/140 (UNII-2C)
Mode 22	TX AX(HE40) Mode Channel 102/110/134 (UNII-2C)
Mode 23	TX AX(HE80) Mode Channel 106 (UNII-2C)
Mode 24	TX A Mode Channel 149/157/165 (UNII-3)
Mode 25	TX AC(VHT20) Mode Channel 149/157/165 (UNII-3)
Mode 26	TX AC(VHT40) Mode Channel 151/159 (UNII-3)
Mode 27	TX AC(VHT80) Mode Channel 155 (UNII-3)
Mode 28	TX AX(HE20) Mode Channel 149/157/165 (UNII-3)
Mode 29	TX AX(HE40) Mode Channel 151/159 (UNII-3)
Mode 30	TX AX(HE80) Mode Channel 155 (UNII-3)

Note:

- (1) For AC power line conducted emissions and radiated emission below 1 GHz test, the TX AX(HE40) Mode Channel 38 (UNII-1) is found to be the worst case and recorded.
- (2) For radiated emission above 1 GHz test, the spurious points of 1GHz~26.5GHz and 26.5GHz~40GHz have been pre-tested and in this report only recorded the worst case. The remaining spurious points are all below the limit value of 20dB.
- (3) For radiated emission Harmonic 18-40GHz test, only tested the worst case and recorded.
- (4) All the bit rate of transmitter have been tested and found the lowest rate is found to be the worst case and recorded.
- (5) VHT20/HT40 covers HT20/HT40, due to same modulation. The power setting for 802.11n HT20 and HT40 are the same or lower than 802.11ac VHT20 and VHT40.
- (6) The measurements for Output Power are tested, the Non Beamforming and Beamforming are recorded in the report. The worst case is Non Beamforming and only the worst case is documented for other test items.
- (7) IEEE 802.11ax mode only supports full RU, so only the full RU is evaluated and measured inside report.
- (8) For radiated emission above 1 GHz test, the polarization of Vertical and Horizontal are evaluated, the worst case is recorded.

3.3 PARAMETERS OF TEST SOFTWARE

Non Beamforming

UNII-1			
Test Software Version	QATool_UIv2.78_DLLv6.83		
Frequency (MHz)	5180	5200	5240
IEEE 802.11a	16	16	15.5
IEEE 802.11ac(VHT20)	18	18	18
IEEE 802.11ax(HE20)	18	18	18
Frequency (MHz)	5190	5230	
IEEE 802.11ac(VHT40)	18	19.5	
IEEE 802.11ax(HE40)	19	18.5	
Frequency (MHz)	5210		
IEEE 802.11ac(VHT80)	19		
IEEE 802.11ax(HE80)	18.5		

UNII-2A			
Test Software Version	QATool_UIv2.78_DLLv6.83		
Frequency (MHz)	5260	5300	5320
IEEE 802.11a	9.5	10	10
IEEE 802.11ac(VHT20)	12	12.5	12.5
IEEE 802.11ax(HE20)	12	12.5	12
Frequency (MHz)	5270	5310	
IEEE 802.11ac(VHT40)	12.5	13	
IEEE 802.11ax(HE40)	12.5	12.5	
Frequency (MHz)	5290		
IEEE 802.11ac(VHT80)	13.5		
IEEE 802.11ax(HE80)	12.5		

UNII-1+UNII-2A	
Test Software Version	QATool_UIv2.78_DLLv6.83
Frequency (MHz)	5250
IEEE 802.11ac(VHT160)	14.5
IEEE 802.11ax(HE160)	14.5

UNII-2C			
Test Software Version	QATool_Uiv2.78_DLLv6.83		
Frequency (MHz)	5500	5580	5700
IEEE 802.11a	10	9.5	9.5
IEEE 802.11ac(VHT20)	12.5	12	12
IEEE 802.11ax(HE20)	12.5	12	12
Frequency (MHz)	5510	5550	5670
IEEE 802.11ac(VHT40)	13.5	13.5	13.5
IEEE 802.11ax(HE40)	13	12.5	12.5
Frequency (MHz)	5530		
IEEE 802.11ac(VHT80)	13.5		
IEEE 802.11ax(HE80)	13		

UNII-3			
Test Software Version	QATool_Uiv2.78_DLLv6.83		
Frequency (MHz)	5745	5785	5825
IEEE 802.11a	17.5	17.5	18
IEEE 802.11ac(VHT20)	19.5	19.5	20
IEEE 802.11ax(HE20)	20	19.5	20
Frequency (MHz)	5755	5795	
IEEE 802.11ac(VHT40)	20	20	
IEEE 802.11ax(HE40)	18	18	
Frequency (MHz)	5775		
IEEE 802.11ac(VHT80)	20		
IEEE 802.11ax(HE80)	19.5		

Beamforming

UNII-1			
Test Software Version	QATool_UIv2.78_DLLv6.83		
Frequency (MHz)	5180	5200	5240
IEEE 802.11ac(VHT20)	17.5	17.5	17.5
IEEE 802.11ax(HE20)	17.5	17.5	17.5
Frequency (MHz)	5190	5230	
IEEE 802.11ac(VHT40)	17.5	19	
IEEE 802.11ax(HE40)	18.5	18	
Frequency (MHz)	5210		
IEEE 802.11ac(VHT80)	18.5		
IEEE 802.11ax(HE80)	18		

UNII-2A			
Test Software Version	QATool_UIv2.78_DLLv6.83		
Frequency (MHz)	5260	5300	5320
IEEE 802.11ac(VHT20)	11.5	12	12
IEEE 802.11ax(HE20)	11.5	12	11.5
Frequency (MHz)	5270	5310	
IEEE 802.11ac(VHT40)	12	12.5	
IEEE 802.11ax(HE40)	12	12	
Frequency (MHz)	5290		
IEEE 802.11ac(VHT80)	13		
IEEE 802.11ax(HE80)	12		

UNII-1+UNII-2A	
Test Software Version	QATool_UIv2.78_DLLv6.83
Frequency (MHz)	5250
IEEE 802.11ac(VHT160)	14
IEEE 802.11ax(HE160)	14

UNII-2C			
Test Software Version	QATool_UIv2.78_DLLv6.83		
Frequency (MHz)	5500	5580	5700
IEEE 802.11ac(VHT20)	12	11.5	11.5
IEEE 802.11ax(HE20)	12	11.5	11.5
Frequency (MHz)	5510	5550	5670
IEEE 802.11ac(VHT40)	13	13	13
IEEE 802.11ax(HE40)	12.5	12	12
Frequency (MHz)	5530		
IEEE 802.11ac(VHT80)	13		
IEEE 802.11ax(HE80)	12.5	12	

UNII-3			
Test Software Version	QATool_UIv2.78_DLLv6.83		
Frequency (MHz)	5745	5785	5825
IEEE 802.11ac(VHT20)	19	19	19.5
IEEE 802.11ax(HE20)	19.5	19	19.5
Frequency (MHz)	5755	5795	
IEEE 802.11ac(VHT40)	19.5	19.5	
IEEE 802.11ax(HE40)	17.5	17.5	
Frequency (MHz)	5775		
IEEE 802.11ac(VHT80)	19.5		
IEEE 802.11ax(HE80)	19		

3.4 DUTY CYCLE

If duty cycle is $\geq 98\%$, duty factor is not required.
 If duty cycle is $< 98\%$, duty factor shall be considered.
 The output power = measured power + duty factor.
 The power spectral density = measured power spectral density + duty factor.

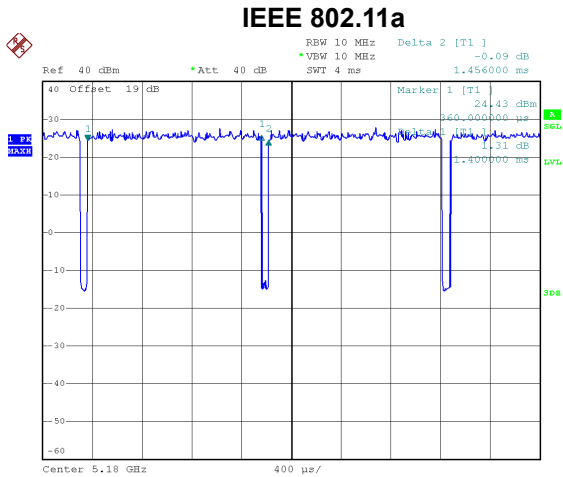

Date: 19.APR.2024 04:01:22

Duty cycle = $1.400 \text{ ms} / 1.456 \text{ ms} = 96.15\%$
 Duty Factor = $10 \log(1 / \text{Duty cycle}) = 0.17$

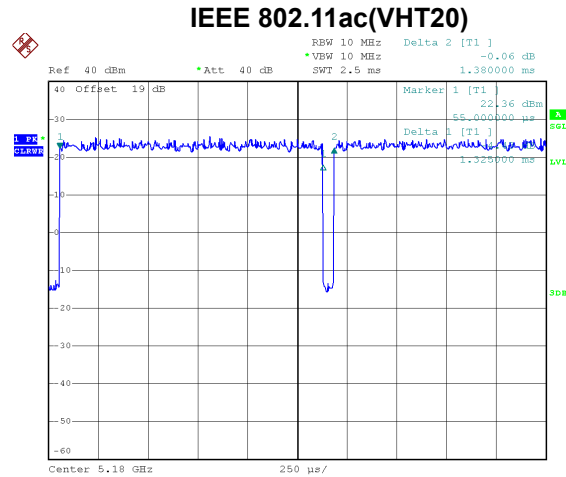

Date: 19.APR.2024 04:02:48

Duty cycle = $1.325 \text{ ms} / 1.380 \text{ ms} = 96.01\%$
 Duty Factor = $10 \log(1 / \text{Duty cycle}) = 0.18$

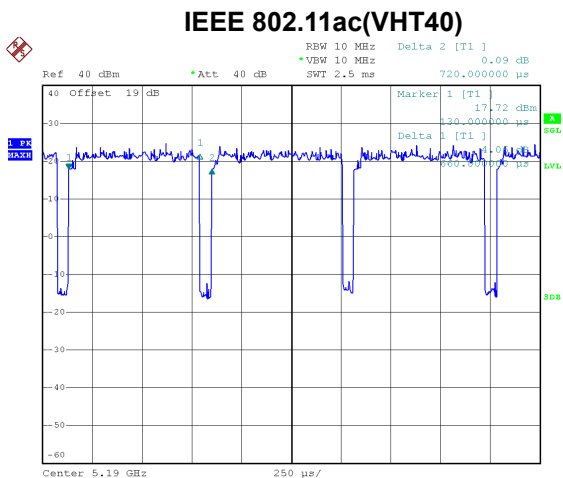

Date: 19.APR.2024 04:03:35

Duty cycle = $0.660 \text{ ms} / 0.720 \text{ ms} = 91.67\%$
 Duty Factor = $10 \log(1 / \text{Duty cycle}) = 0.38$

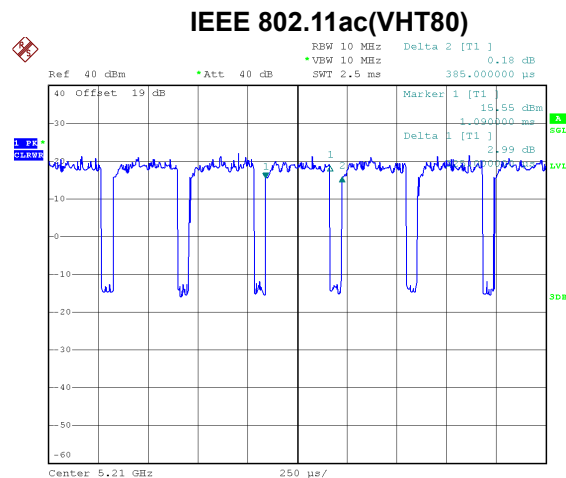

Date: 19.APR.2024 04:05:23

Duty cycle = $0.325 \text{ ms} / 0.385 \text{ ms} = 84.42\%$
 Duty Factor = $10 \log(1 / \text{Duty cycle}) = 0.74$

IEEE 802.11ac(VHT160)

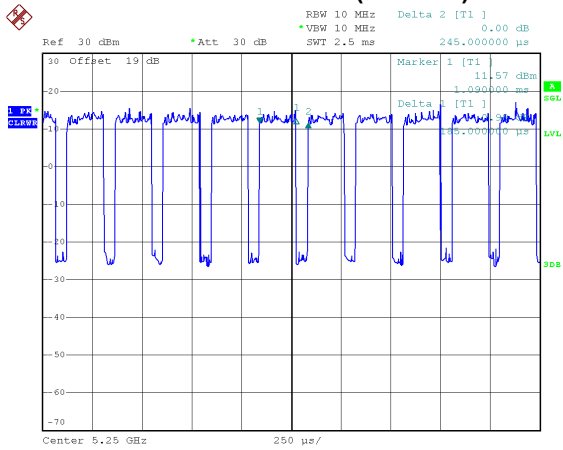

Date: 19.APR.2024 04:07:33

Duty cycle = 0.185 ms / 0.245 ms = 75.51%
 Duty Factor = 10 log(1 / Duty cycle) = 1.22

IEEE 802.11ax(HE20)

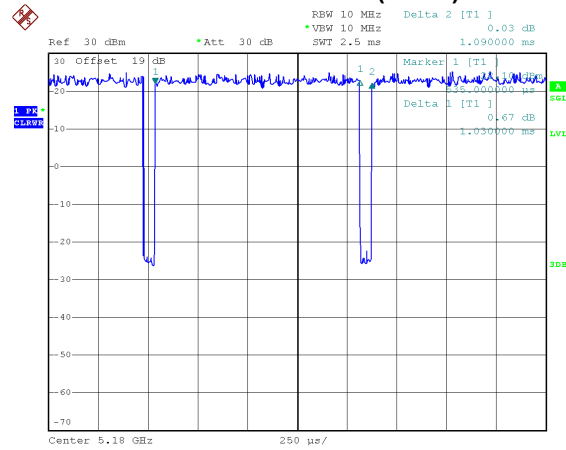

Date: 19.APR.2024 04:09:20

Duty cycle = 1.030 ms / 1.090 ms = 94.50%
 Duty Factor = 10 log(1 / Duty cycle) = 0.25

IEEE 802.11ax(HE40)

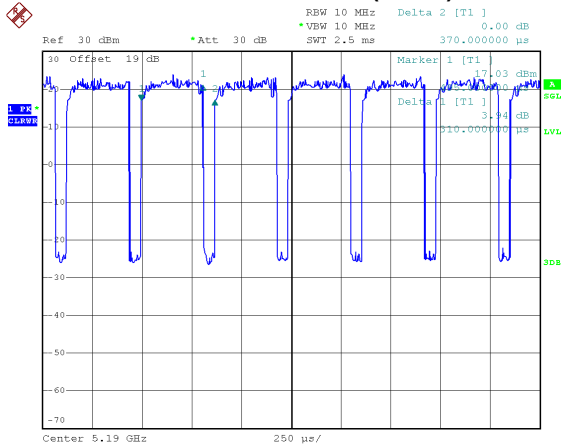

Date: 19.APR.2024 04:10:38

Duty cycle = 0.310 ms / 0.370 ms = 83.78%
 Duty Factor = 10 log(1 / Duty cycle) = 0.77

IEEE 802.11ax(HE80)

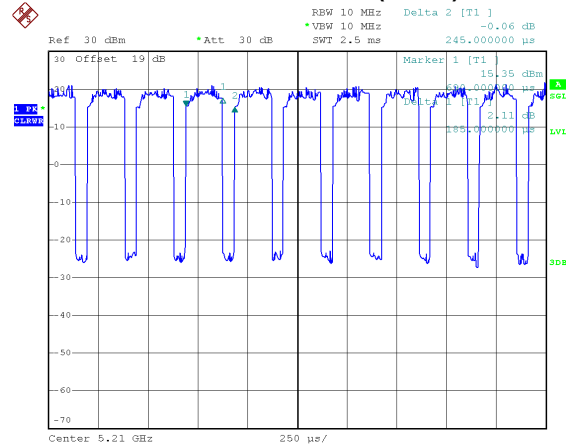

Date: 19.APR.2024 04:11:40

Duty cycle = 0.185 ms / 0.245 ms = 75.51%
 Duty Factor = 10 log(1 / Duty cycle) = 1.22

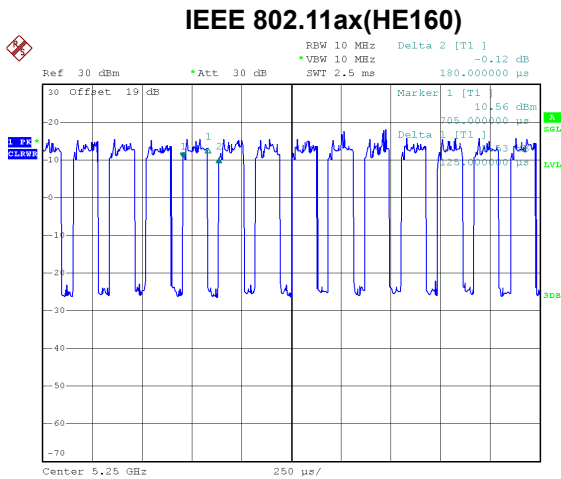

Date: 19.APR.2024 04:13:51

Duty cycle = 0.125 ms / 0.180 ms = 69.44%
 Duty Factor = 10 log(1 / Duty cycle) = 1.58

NOTE:

For IEEE 802.11a:

For radiated emissions frequency above 1 GHz, the resolution bandwidth of test receiver/spectrum analyzer is 1 MHz and the video bandwidth is 714 Hz (Duty cycle < 98%).

For IEEE 802.11ac(VHT20):

For radiated emissions frequency above 1 GHz, the resolution bandwidth of test receiver/spectrum analyzer is 1 MHz and the video bandwidth is 755 Hz (Duty cycle < 98%).

For IEEE 802.11ac(VHT40):

For radiated emissions frequency above 1 GHz, the resolution bandwidth of test receiver/spectrum analyzer is 1 MHz and the video bandwidth is 1515 Hz (Duty cycle < 98%).

For IEEE 802.11ac(VHT80):

For radiated emissions frequency above 1 GHz, the resolution bandwidth of test receiver/spectrum analyzer is 1 MHz and the video bandwidth is 3077 Hz (Duty cycle < 98%).

For IEEE 802.11ac(VHT160):

For radiated emissions frequency above 1 GHz, the resolution bandwidth of test receiver/spectrum analyzer is 1 MHz and the video bandwidth is 5405 Hz (Duty cycle < 98%).

For IEEE 802.11ax(HE20):

For radiated emissions frequency above 1 GHz, the resolution bandwidth of test receiver/spectrum analyzer is 1 MHz and the video bandwidth is 971 Hz (Duty cycle < 98%).

For IEEE 802.11ax(HE40):

For radiated emissions frequency above 1 GHz, the resolution bandwidth of test receiver/spectrum analyzer is 1 MHz and the video bandwidth is 3226 Hz (Duty cycle < 98%).

For IEEE 802.11ax(HE80):

For radiated emissions frequency above 1 GHz, the resolution bandwidth of test receiver/spectrum analyzer is 1 MHz and the video bandwidth is 5405 Hz (Duty cycle < 98%).

For IEEE 802.11ax(HE160):

For radiated emissions frequency above 1 GHz, the resolution bandwidth of test receiver/spectrum analyzer is 1 MHz and the video bandwidth is 8000 Hz (Duty cycle < 98%).

3.5 BLOCK DIAGRAM SHOWING THE CONFIGURATION OF SYSTEM TESTED

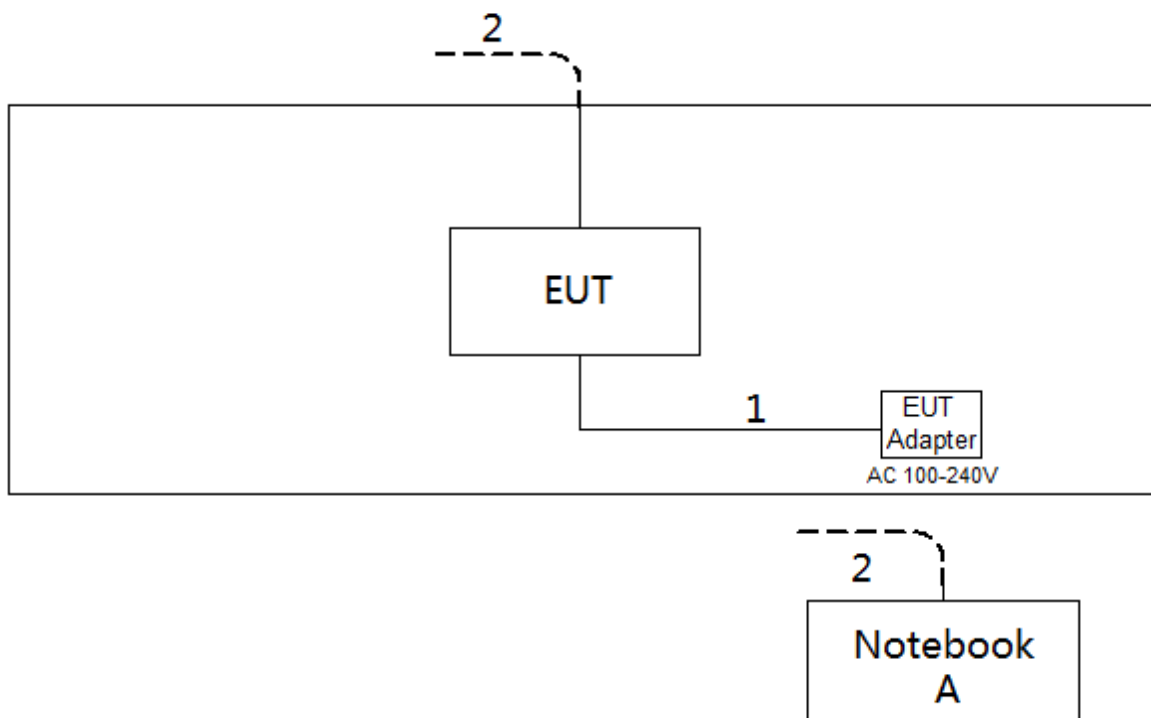

3.6 SUPPORT UNITS

Item	Equipment	Brand	Model No.	Series No.
A	Notebook	Dell	INSPIRON 5493	N/A

Item	Cable Type	Shielded Type	Ferrite Core	Length
1	DC Cable	NO	NO	1.5m
2	RJ45 Cable	NO	NO	10m

3.7 CUSTOMER INFORMATION DESCRIPTION

- 1) The antenna gain and beamforming gain are provided by the manufacturer.
- 2) Except for AC power line conducted emissions and radiated emissions, the results of all test items include cable losses. All cable losses are provided by the testing laboratory.

4. AC POWER LINE CONDUCTED EMISSIONS

4.1 LIMIT

Frequency (MHz)	Limit (dB μ V)	
	Quasi-peak	Average
0.15 - 0.5	66 to 56*	56 to 46*
0.5 - 5.0	56	46
5.0 - 30.0	60	50

NOTE:

- (1) The tighter limit applies at the band edges.
- (2) The limit of " * " marked band means the limitation decreases linearly with the logarithm of the frequency in the range.

4.2 TEST PROCEDURE

- a. The EUT was placed 0.8 meters from the horizontal ground plane with EUT being connected to the power mains through a line impedance stabilization network (LISN). All other support equipment powered from additional LISN(s). The LISN provide 50 Ohm/ 50uH of coupling impedance for the measuring instrument.
- b. Interconnecting cables that hang closer than 40 cm to the ground plane shall be folded back and forth in the center forming a bundle 30 to 40 cm long.
- c. I/O cables that are not connected to a peripheral shall be bundled in the center. The end of the cable may be terminated, if required, using the correct terminating impedance. The overall length shall not exceed 1 m.
- d. LISN at least 80 cm from nearest part of EUT chassis.
- e. For the actual test configuration, please refer to the related Item -EUT Test Photos.

The following table is the setting of the receiver:

Receiver Parameter	Setting
Start Frequency	0.15 MHz
Stop Frequency	30 MHz
IF Bandwidth	9 kHz

4.3 DEVIATION FROM TEST STANDARD

No deviation

4.4 TEST SETUP

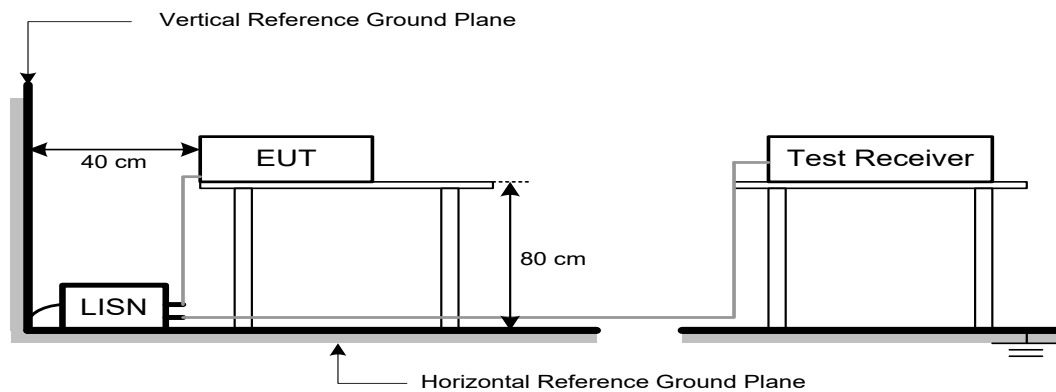

4.5 EUT OPERATION CONDITIONS

The EUT was configured for testing in a typical fashion (as a customer would normally use it). The EUT has been programmed to continuously transmit during test. This operating condition was tested and used to collect the included data.

The EUT was programmed to be in continuously transmitting/TX mode.

4.6 TEST RESULTS

Please refer to the APPENDIX A.

5. RADIATED EMISSIONS

5.1 LIMIT

In case the emission fall within the restricted band specified on 15.205(a), then the 15.209(a) limit in the table below has to be followed.

LIMITS OF RADIATED EMISSIONS MEASUREMENT (9 kHz to 1000 MHz)

Frequency (MHz)	Field Strength (microvolts/meter)	Measurement Distance (meters)
0.009-0.490	2400/F(kHz)	300
0.490-1.705	24000/F(kHz)	30
1.705-30.0	30	30
30-88	100	3
88-216	150	3
216-960	200	3
Above 960	500	3

LIMITS OF UNWANTED EMISSION OUT OF THE RESTRICTED BANDS (Above 1000 MHz)

Frequency (MHz)	EIRP Limit (dBm/MHz)	Band edge at 3m (dBμV/m)	Harmonic at 1m (dBμV/m)
5150-5250	-27	68.2	77.7 (Note 3)
5250-5350	-27	68.2	77.7 (Note 3)
5470-5725	-27	68.2	77.7 (Note 3)
5725-5850 NOTE (2)	-27	68.2	77.7 (Note 3)
	10	105.2	114.7 (Note 3)
	15.6	110.8	120.3 (Note 3)
	27	122.2	131.7 (Note 3)

NOTE:

(1) The following formula is used to convert the equipment isotropic radiated power (eirp) to field strength:

$$E = \frac{1000000\sqrt{30P}}{3} \mu\text{V/m, where P is the eirp (Watts)}$$

(2) According to 15.407(b)(4)(i), all emissions shall be limited to a level of -27 dBm/MHz at 75 MHz or more above or below the band edge increasing linearly to 10 dBm/MHz at 25 MHz above or below the band edge, and from 25 MHz above or below the band edge increasing linearly to a level of 15.6 dBm/MHz at 5 MHz above or below the band edge, and from 5 MHz above or below the band edge increasing linearly to a level of 27 dBm/MHz at the band edge.

(3)

$$FS_{\text{limit}} = FS_{\text{max}} - 20\log\left(\frac{d_{\text{limit}}}{d_{\text{measure}}}\right)$$

$$20\log(d_{\text{limit}}/d_{\text{measure}}) = 20\log(3/1) = 9.5 \text{ dB.}$$

5.2 TEST PROCEDURE

- a. The measuring distance of 3 m shall be used for measurements. The EUT was placed on the top of a rotating table 0.8 meter above the ground at a 3 meter semi-anechoic chamber. The table was rotated 360 degrees to determine the position of the highest radiation.(below 1GHz)
- b. The measuring distance of 3 m or 1m shall be used for measurements. The EUT was placed on the top of a rotating table 1.5 meter above the ground at a 3 meter semi-anechoic chamber. The table was rotated 360 degrees to determine the position of the highest radiation.(above 1GHz)
- c. The height of the equipment or of the substitution antenna shall be 0.8m or 1.5m; the height of the test antenna shall vary between 1 m to 4 m. Both horizontal and vertical polarizations of the antenna are set to make the measurement.
- d. For each suspected emission, the EUT was arranged to its worst case and then the antenna was tuned to heights find the maximum reading (used Bore sight function).
- e. The receiver system was set to peak and average detect function and specified bandwidth with maximum hold mode when the test frequency is above 1 GHz.
- f. The initial step in collecting radiated emission data is a receiver peak detector mode pre-scanning the measurement frequency range. Significant peaks are then marked and then Quasi Peak detector mode re-measured.
- g. All readings are Peak unless otherwise stated QP in column of Note. Peak denotes that the Peak reading compliance with the QP Limits and then QP Mode measurement didn't perform.
(below 1 GHz)
- h. All readings are Peak Mode value unless otherwise stated AVG in column of Note. If the Peak Mode Measured value compliance with the Peak Limits and lower than AVG Limits, the EUT shall be deemed to meet both Peak & AVG Limits and then only Peak Mode was measured, but AVG Mode didn't perform. (above 1 GHz)
- i. For the actual test configuration, please refer to the related Item –EUT Test Photos.

The following table is the setting of the receiver:

Spectrum Parameters	Setting
Start ~ Stop Frequency	9 kHz~150 kHz for RBW 200 Hz
Start ~ Stop Frequency	0.15 MHz~30 MHz for RBW 9 kHz
Start ~ Stop Frequency	30 MHz~1000 MHz for RBW 100 kHz

Spectrum Parameters	Setting
Start Frequency	1000 MHz
Stop Frequency	10th carrier harmonic or 40 GHz, whichever is lower
RBW / VBW (Emission in restricted band)	1 MHz / 3 MHz for PK value 1 MHz / 1/T Hz for AVG value

Receiver Parameters	Setting
Start ~ Stop Frequency	9 kHz~90 kHz for PK/AVG detector
Start ~ Stop Frequency	90 kHz~110 kHz for QP detector
Start ~ Stop Frequency	110 kHz~490 kHz for PK/AVG detector
Start ~ Stop Frequency	490 kHz~30 MHz for QP detector
Start ~ Stop Frequency	30 MHz~1000 MHz for QP detector
Start ~ Stop Frequency	1 GHz~40 GHz for PK/AVG detector

5.3 DEVIATION FROM TEST STANDARD

No deviation.

5.4 TEST SETUP

9 kHz to 30 MHz

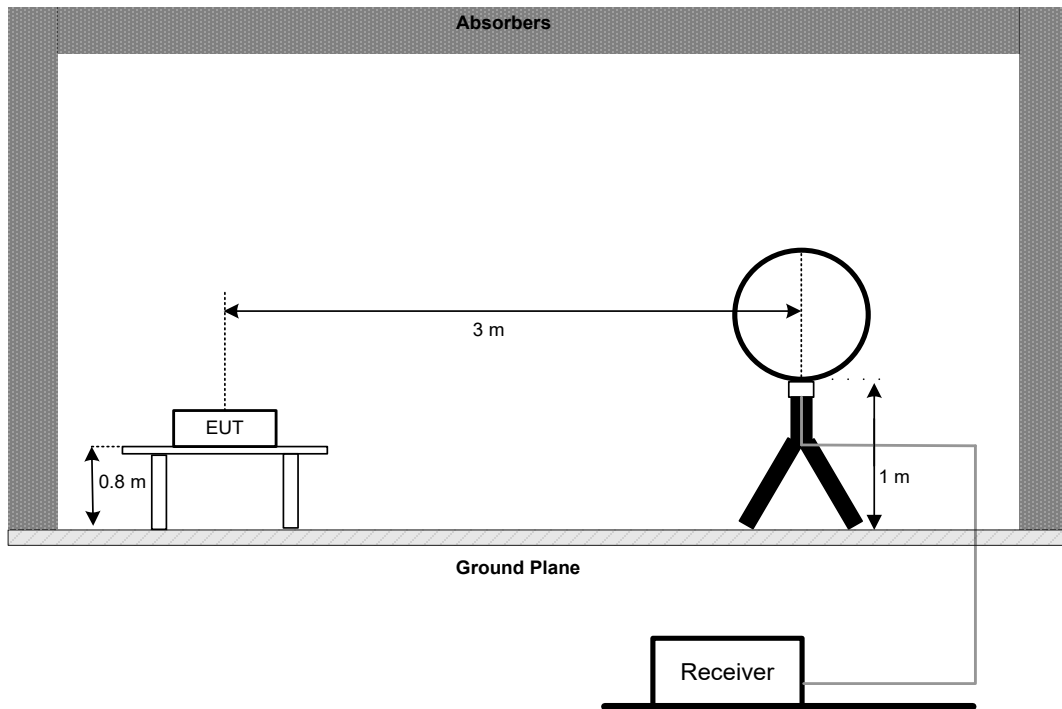

30 MHz to 1 GHz

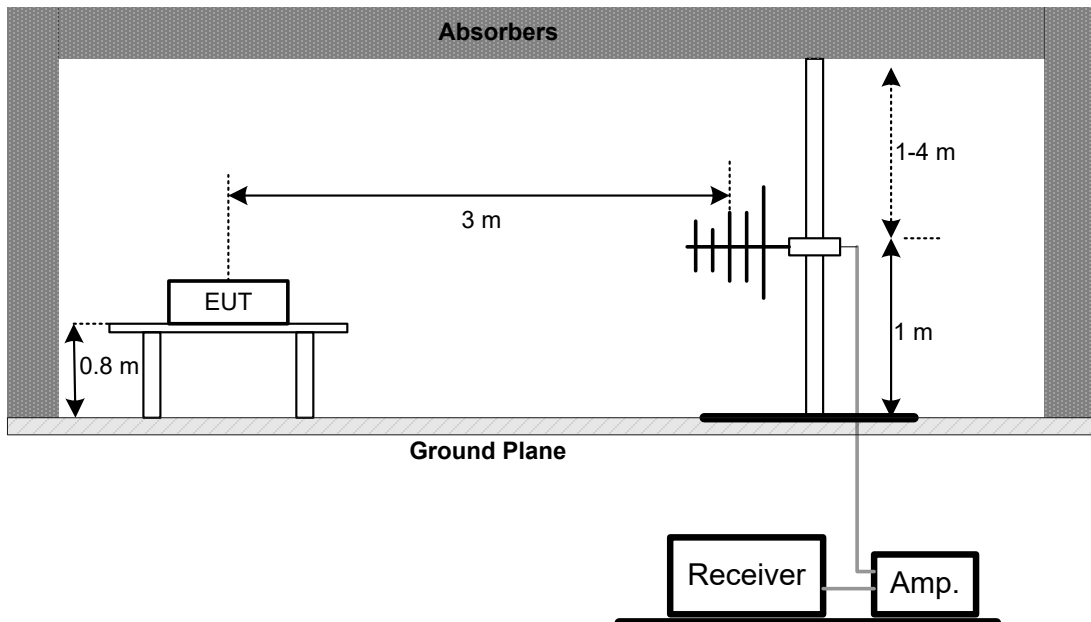

**Above 1 GHz
Band edge**

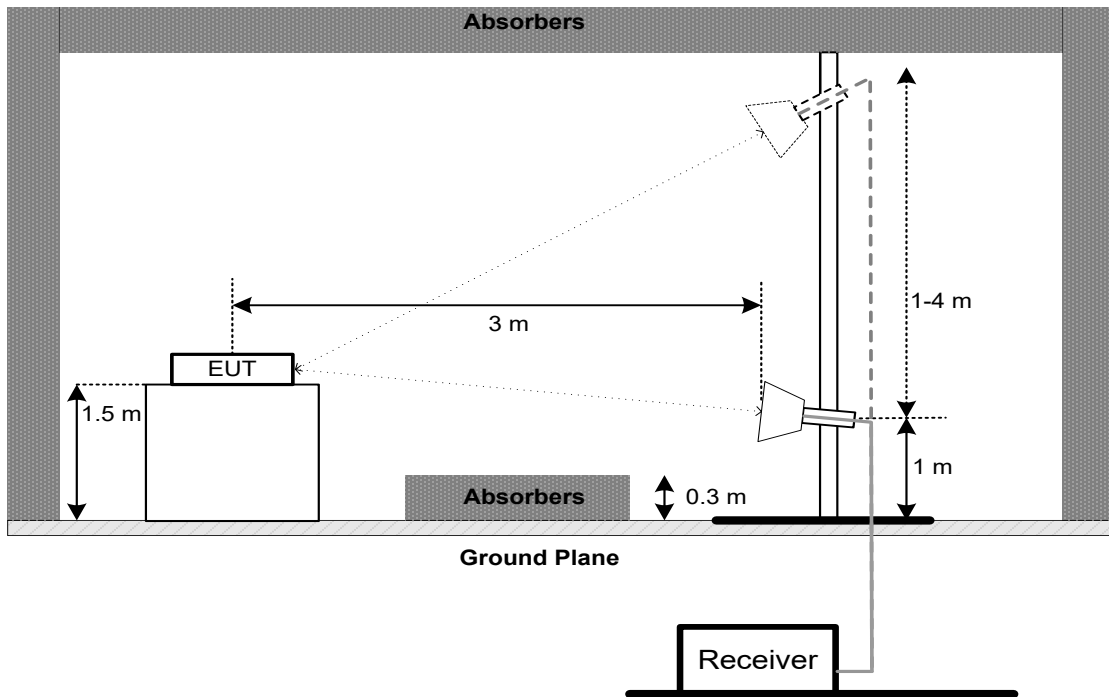

Harmonic (1 GHz to 18 GHz)

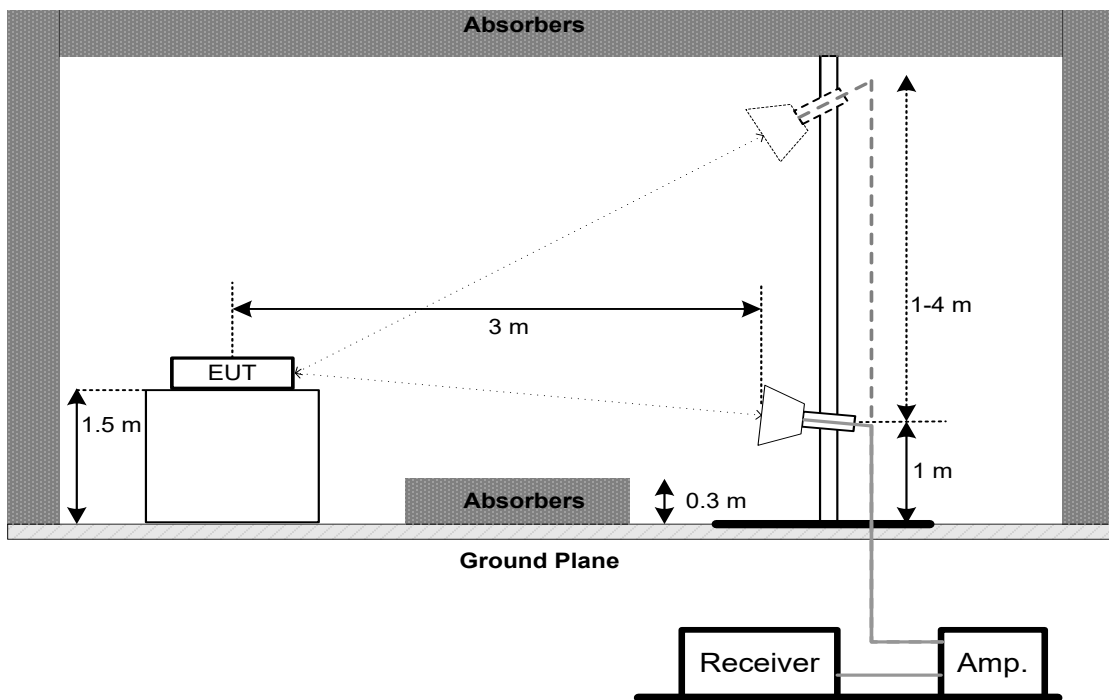

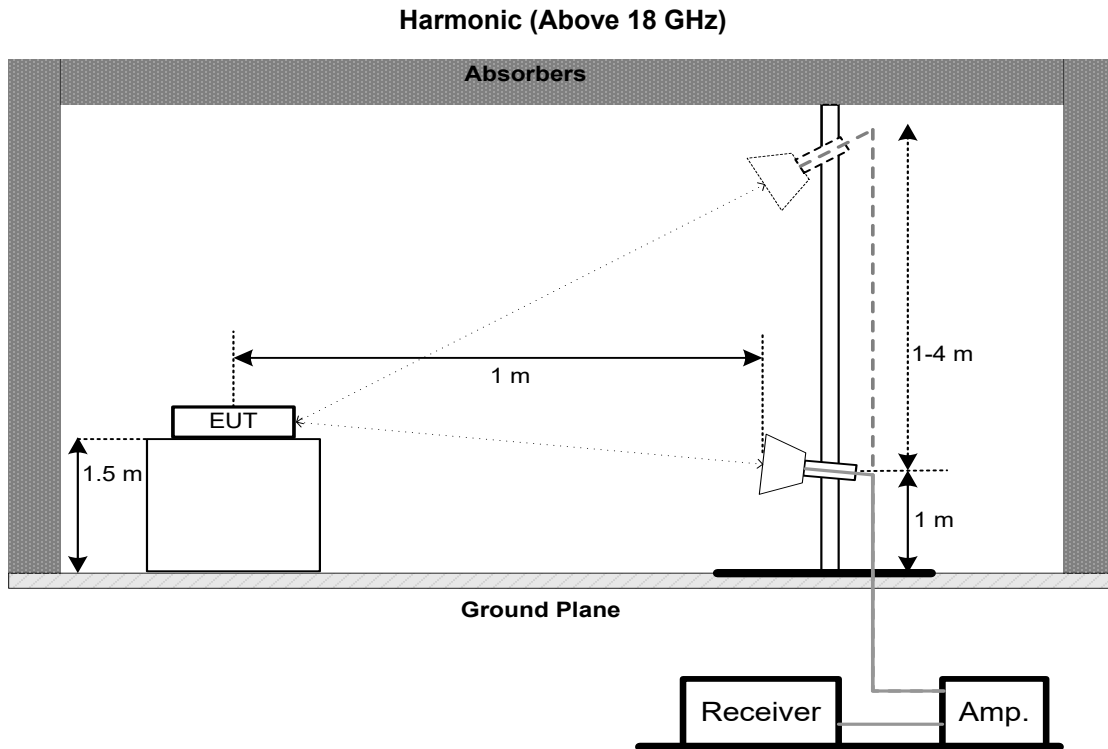

5.5 EUT OPERATION CONDITIONS

The EUT tested system was configured as the statements of 3.5 unless otherwise a special operating condition is specified in the follows during the testing.

5.6 TEST RESULTS - 9 KHZ TO 30 MHZ

Please refer to the APPENDIX B.

Remark:

- (1) Distance extrapolation factor = $40 \log (\text{specific distance} / \text{test distance})$ (dB).
- (2) Limit line = specific limits (dBuV) + distance extrapolation factor.

5.7 TEST RESULTS - 30 MHZ TO 1000 MHZ

Please refer to the APPENDIX C.

5.8 TEST RESULTS - ABOVE 1000 MHZ

Please refer to the APPENDIX D.

Remark:

- (1) No limit: This is fundamental signal, the judgment is not applicable.
For fundamental signal judgment was referred to Peak output test.

6. BANDWIDTH

6.1 LIMIT

Section	Test Item	Limit	Frequency Range (MHz)
FCC 15.407(a) FCC 15.407(e)	26 dB Bandwidth	-	5150-5250
	26 dB Bandwidth	-	5250-5350
	26 dB Bandwidth	-	5470-5600 5650-5725
	6 dB Bandwidth	Minimum 500 kHz	5725-5850

6.2 TEST PROCEDURE

- a. The EUT was directly connected to the spectrum analyzer and antenna output port as show in the block diagram below
- b. Spectrum Setting:

For UNII-1, UNII-2A, UNII-2C:

Spectrum Parameter	Setting
Span Frequency	> 26 dB Bandwidth
RBW	Appromiximately 1% of the emission bandwidth
VBW	> RBW
Detector	Peak
Trace	Max Hold
Sweep Time	Auto

For UNII-3:

Spectrum Parameter	Setting
Span Frequency	> 6 dB Bandwidth
RBW	100 kHz
VBW	300 kHz
Detector	Peak
Trace	Max Hold
Sweep Time	Auto

For 99% Occupied Bandwidth:

Spectrum Parameter	Setting
Span Frequency	1.5 times to 5 times the OBW
RBW	1% to 5% of the OBW
VBW	$\geq 3 \times \text{RBW}$
Detector	Peak
Trace	Max Hold
Sweep Time	Auto

- c. Measured the spectrum width with power higher than 26 dB / 6 dB below carrier.

6.3 DEVIATION FROM STANDARD

No deviation.

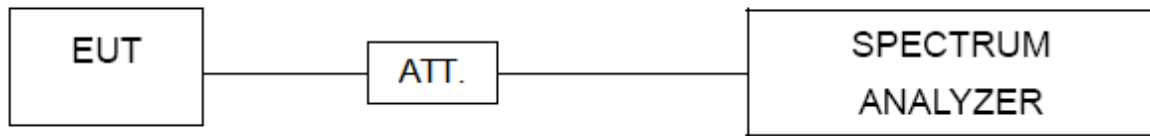
6.4 TEST SETUP**6.5 EUT OPERATION CONDITIONS**

The EUT was programmed to be in continuously transmitting mode.

6.6 TEST RESULTS

Please refer to the APPENDIX E.

7. MAXIMUM OUTPUT POWER

7.1 LIMIT

Section	Test Item	Limit	Frequency Range (MHz)
FCC 15.407(a)	Maximum Output Power	AP device: 1 Watt (30 dBm) Client device: 250 mW (23.98 dBm)	5150-5250
		250 mW (23.98 dBm)	5250-5350
		250 mW (23.98 dBm)	5470-5600 5650-5725
		1 Watt (30dBm)	5725-5850

Note:

- a. For an indoor access point operating in the band 5.15-5.25 GHz, the maximum conducted output power over the frequency band of operation shall not exceed 1 W provided the maximum antenna gain does not exceed 6 dBi. In addition, the maximum power spectral density shall not exceed 17 dBm in any 1 megahertz band. If transmitting antennas of directional gain greater than 6 dBi are used, both the maximum conducted output power and the maximum power spectral density shall be reduced by the amount in dB that the directional gain of the antenna exceeds 6 dBi.
- b. For the 5.25-5.35 GHz and 5.47-5.725 GHz bands, the maximum conducted output power over the frequency bands of operation shall not exceed the lesser of 250 mW or 11 dBm + 10log B, where B is the 26dB Bandwidth in megahertz.

7.2 TEST PROCEDURE

- a. The EUT was directly connected to the peak power analyzer and antenna output port as show in the block diagram below.
- b. The test was performed in accordance with method of FCC KDB 789033 D02 General UNII Test Procedures New Rules v02r01.

7.3 DEVIATION FROM STANDARD

No deviation.

7.4 TEST SETUP

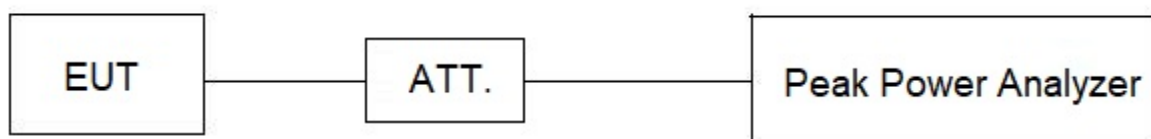

7.5 EUT OPERATION CONDITIONS

The EUT was programmed to be in continuously transmitting mode.

7.6 TEST RESULTS

Please refer to the APPENDIX F.

8. POWER SPECTRAL DENSITY

8.1 LIMIT

Section	Test Item	Limit	Frequency Range (MHz)
FCC 15.407(a)	Power Spectral Density	AP device: 17 dBm/MHz Client device: 11 dBm/MHz	5150-5250
		11 dBm/MHz	5250-5350
		11 dBm/MHz	5470-5600 5650-5725
		30 dBm/500 kHz	5725-5850

8.2 TEST PROCEDURE

a. The EUT was directly connected to the spectrum analyzer and antenna output port as show in the block diagram below.

b. Spectrum Setting:

For UNII-1, UNII-2A, UNII-2C:

Spectrum Parameter	Setting
Span Frequency	Encompass the entire emissions bandwidth (EBW) of the signal
RBW	1 MHz.
VBW	3 MHz.
Detector	RMS
Trace average	100 trace
Sweep Time	Auto

For UNII-3:

Spectrum Parameter	Setting
Span Frequency	Encompass the entire emissions bandwidth (EBW) of the signal
RBW	100 kHz.
VBW	300 kHz.
Detector	RMS
Trace average	100 trace
Sweep Time	Auto

Note:

- For UNII-3, according to KDB publication 789033 D02 General UNII Test Procedures New Rules v02r01, section II.F.5., it is acceptable to set RBW at 100kHz and VBW at 300kHz if the spectrum analyzer does not have 500 kHz RBW. Then, add $10 \log(500 \text{ kHz}/100 \text{ kHz})$ to the measured result, i.e. 7 dB.
- During the test of U-NII 3 PSD, the measurement result with RBW=100kHz has been added 7 dB by compensating offset. For example, the cable loss is 13 dB, and the final offset is $19 + 7 = 26$ dB when RBW=100kHz is used.

8.3 DEVIATION FROM STANDARD

No deviation.

8.4 TEST SETUP

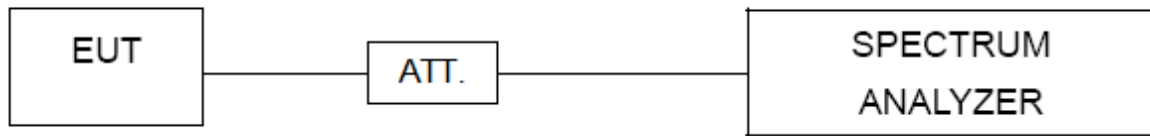

8.5 EUT OPERATION CONDITIONS

The EUT was programmed to be in continuously transmitting mode.

8.6 TEST RESULTS

Please refer to the APPENDIX G.

9. FREQUENCY STABILITY

9.1 LIMIT

Section	Test Item	Limit	Frequency Range (MHz)
FCC 15.407(g)	Frequency Stability	An emission is maintained within the band of operation under all conditions of normal operation as specified in the users manual.	5150-5250
			5250-5350
			5470-5600
			5650-5725
			5725-5850

9.2 TEST PROCEDURE

- a. The EUT was directly connected to the spectrum analyzer and antenna output port as show in the block diagram below.
- b. Spectrum Setting:

Spectrum Parameter	Setting
Span Frequency	Entire absence of modulation emissions bandwidth
RBW	10 kHz
VBW	10 kHz
Detector	Peak
Trace	Max Hold
Sweep Time	Auto

- c. The test extreme voltage is to change the primary supply voltage from 85 to 115 percent of the nominal value.
- d. User manual temperature is 0°C~40°C.

9.3 DEVIATION FROM STANDARD

No deviation.

9.4 TEST SETUP

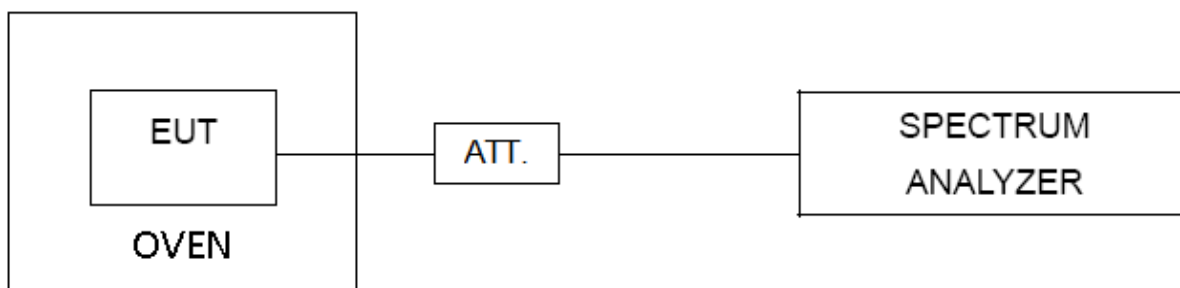

9.5 EUT OPERATION CONDITIONS

The EUT was programmed to be in continuously transmitting mode.

9.6 TEST RESULTS

Please refer to the APPENDIX H.

10. MEASUREMENT INSTRUMENTS LIST

AC Power Line Conducted Emissions					
Item	Kind of Equipment	Manufacturer	Type No.	Serial No.	Calibrated until
1	EMI Test Receiver	R&S	ESR3	103027	Jun. 16, 2024
2	TWO-LINE V-NETWORK	R&S	ENV216	101447	Dec. 22, 2024
3	Measurement Software	Farad	EZ-EMC Ver.NB-03A1-01	N/A	N/A
4	Cable	N/A	SFT205-NMNM-9M -001	9M	Nov. 27, 2024
5	643 Shield Room	ETS	6*4*3	N/A	N/A

Radiated Emissions - 9 kHz to 30 MHz					
Item	Kind of Equipment	Manufacturer	Type No.	Serial No.	Calibrated until
1	Active Loop Antenna	Schwarzbeck	FMZB 1513-60B	1513-60 B-034	Mar. 31, 2024 Mar. 30, 2025
2	MXE EMI Receiver	Keysight	N9038A	MY56400091	Dec. 22, 2024
3	Cable	N/A	RW2350-3.8A-NMB M-1.5M	N/A	Jun. 10, 2024
4	Measurement Software	Farad	EZ-EMC Ver.NB-03A1-01	N/A	N/A
5	966 Chamber room	ETS	9*6*6	N/A	Jul. 11, 2024

Radiated Emissions - 30 MHz to 1 GHz					
Item	Kind of Equipment	Manufacturer	Type No.	Serial No.	Calibrated until
1	Trilog-Broadband Antenna	Schwarzbeck	VULB 9168	1462	Dec. 13, 2024
2	Attenuator	EMC INSTRUMENT	EMCI-N-6-06	AT-06009	Dec. 13, 2024
3	Preamplifier	EMC INSTRUMENT	EMC001330	980998	Nov. 17, 2024
4	Cable	RegalWay	LMR400-NMNM -12.5m	N/A	Jul. 04, 2024
5	Cable	RegalWay	LMR400-NMNM -3m	N/A	Jul. 04, 2024
6	Cable	RegalWay	LMR400-NMNM -0.5m	N/A	Jul. 04, 2024
7	Receiver	Agilent	N9038A	MY52130039	Dec. 22, 2024
8	Positioning Controller	MF	MF-7802	N/A	N/A
9	Measurement Software	Farad	EZ-EMC Ver.NB-03A1-01	N/A	N/A
10	966 Chamber room	CM	9*6*6	N/A	May 17, 2024 May 16, 2025

Radiated Emissions - Above 1 GHz					
Item	Kind of Equipment	Manufacturer	Type No.	Serial No.	Calibrated until
1	Receiver	Agilent	N9038A	MY52130039	Dec. 22, 2024
2	Preamplifier	EMC INSTRUMENT	EMC118A45SE	980888	Nov. 17, 2024
3	EXA Spectrum Analyzer	Keysight	N9010A	MY55150209	Jun. 16, 2024
4	Double Ridged Guide Antenna	ETS	3115	75789	May 31, 2024
5	Cable	RegalWay	RWLP50-4.0A-SMS M-12.5M	N/A	Feb. 19, 2025
6	Cable	RegalWay	RWLP50-4.0A-NM RASM-2.5M	N/A	Aug. 08, 2024
7	Cable	RegalWay	RWLP50-4.0A-NM RASMRA-0.8M	N/A	Aug. 08, 2024
8	Low Noise Amplifier	CONNPHY	CLN-18G40G-4330 -K	619413	Jul. 06, 2024
9	Cable	RegalWay	RWLP50-2.6A-2.92 M2.92M-1.1M	N/A	Jul. 26, 2024
10	Cable	Tonscend	HF160-KMKM-3M	N/A	Jul. 26, 2024
11	Broad-Band Horn Antenna	Schwarzbeck	BBHA9170(3m)	9170-319	Jun. 20, 2024
12	966 Chamber room	CM	9*6*6	N/A	May 17, 2024 May 16, 2025
13	Filter	STI	BRC50703-01	N/A	Dec. 22, 2024
14	Filter	STI	STI15-9969	N/A	Jun. 16, 2024
15	Positioning Controller	MF	MF-7802	N/A	N/A
16	Measurement Software	Farad	EZ-EMC Ver.NB-03A1-01	N/A	N/A
17	Attenuator	Talent Microwave	TA10A2-S-18	N/A	N/A

Bandwidth & Power Spectral Density					
Item	Kind of Equipment	Manufacturer	Type No.	Serial No.	Calibrated until
1	Spectrum Analyzer	R&S	FSP40	100185	Jun. 16, 2024
2	Attenuator	Talent Microwave	TA10A0-S-26.5	N/A	N/A
3	Attenuator	Talent Microwave	TA10A0-S-26.5	N/A	N/A
4	DC Block	N/A	N/A	N/A	N/A
5	Measurement Software	BTL	BTL Conducted Test	N/A	N/A

Maximum Output Power					
Item	Kind of Equipment	Manufacturer	Type No.	Serial No.	Calibrated until
1	Attenuator	RegalWay	RWA-201-S-10	NA	Sep. 26, 2024
2	Power sensors	MA24408A	12592	NA	Dec. 22, 2024
3	MA24400A PEAK POWER ANALYZER	VERSION 1.1.0.0	N/A	N/A	N/A

Frequency Stability					
Item	Kind of Equipment	Manufacturer	Type No.	Serial No.	Calibrated until
1	Spectrum Analyzer	R&S	FSP40	100185	Jun. 16, 2024
2	Attenuator	Talent Microwave	TA10A0-S-26.5	N/A	N/A
3	Attenuator	Talent Microwave	TA10A0-S-26.5	N/A	N/A
4	DC Block	N/A	N/A	N/A	N/A
5	Measurement Software	BTL	BTL Conducted Test	N/A	N/A
6	Multi-output DC Power Supply	GW Instek	GPC-3030DN	EK880675	Jul. 07, 2024
7	Table top type high and low temperature test chamber	CEPREI	CEEC-M64T-40	15-008	Dec. 22, 2024
8	Cable	Woke	S02-190515-03	N/A	N/A

Remark: "N/A" denotes no model name, serial no. or calibration specified.

All calibration period of equipment list is one year.

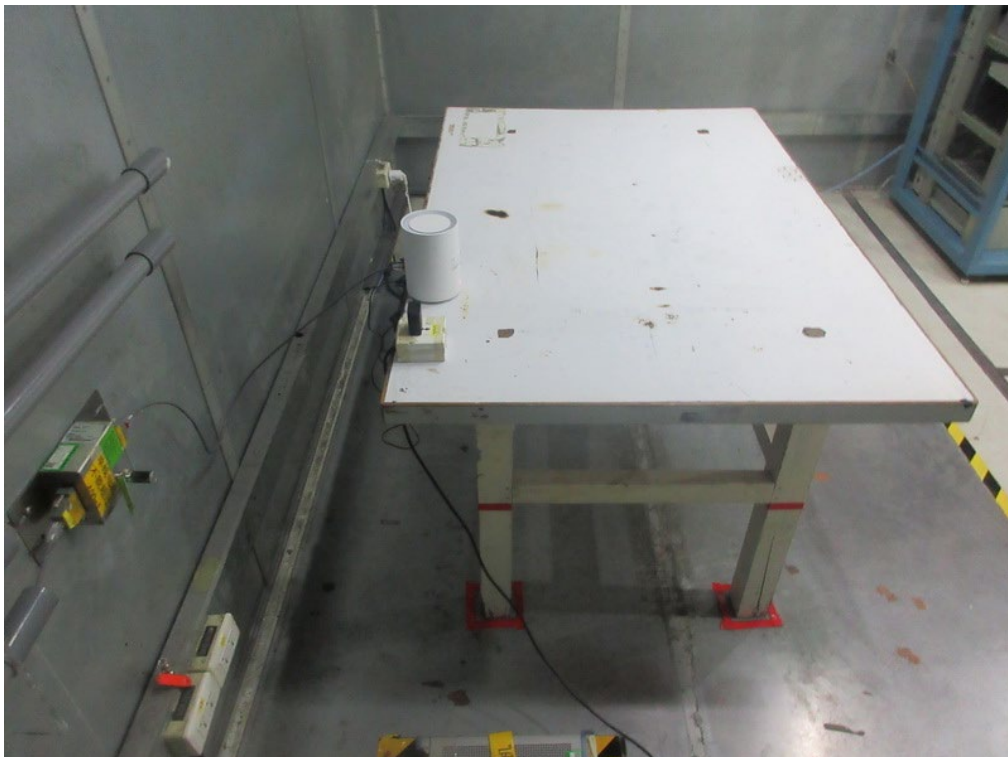
11. EUT TEST PHOTOS**AC Power Line Conducted Emissions Test Photos**

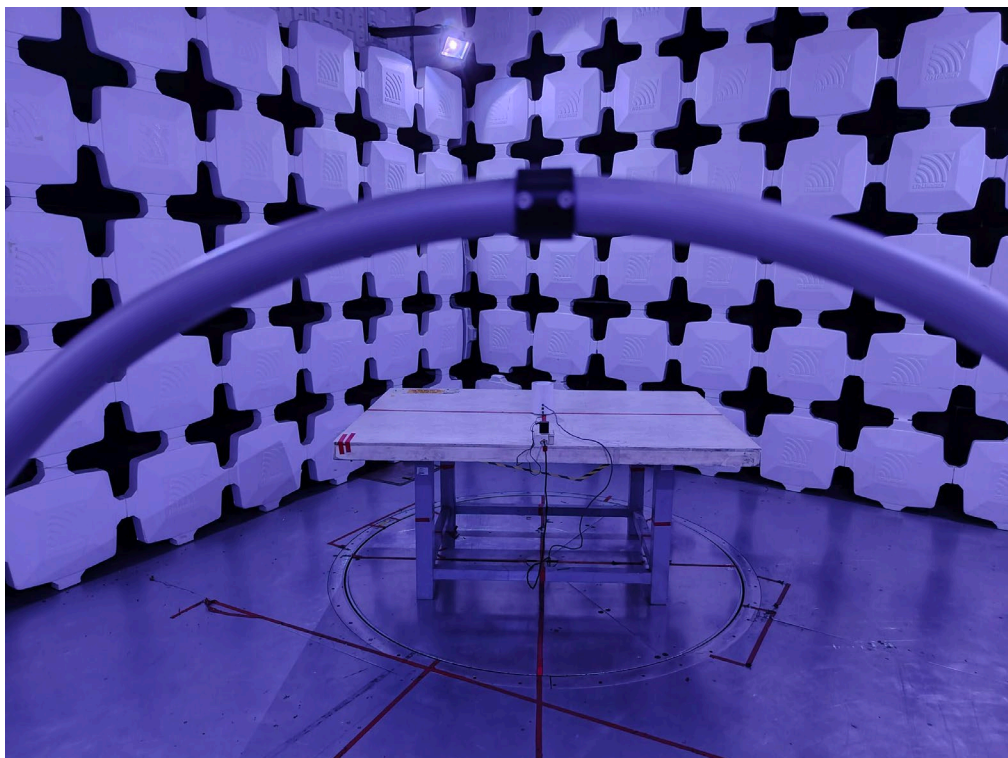
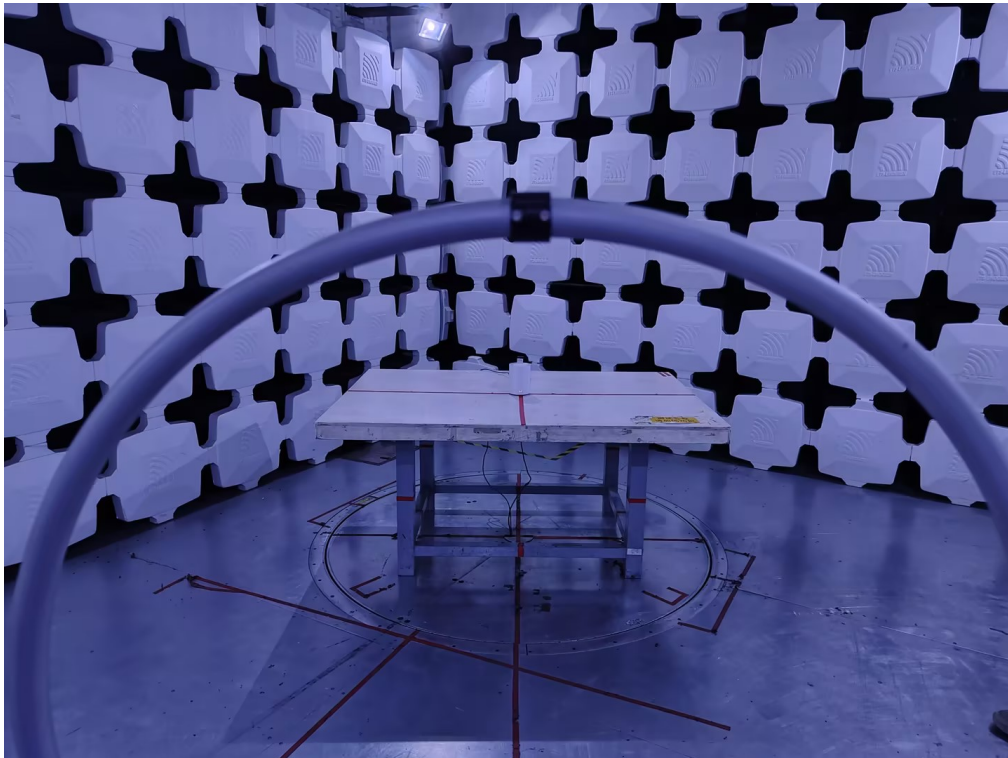
Radiated Emissions Test Photos**9 kHz to 30 MHz**

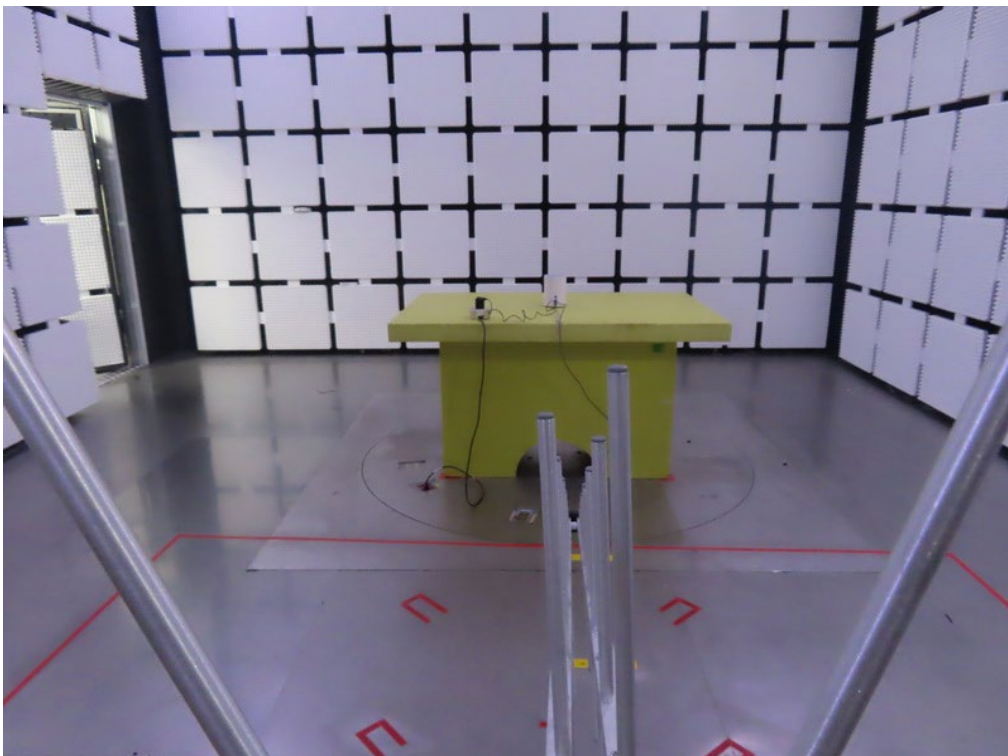
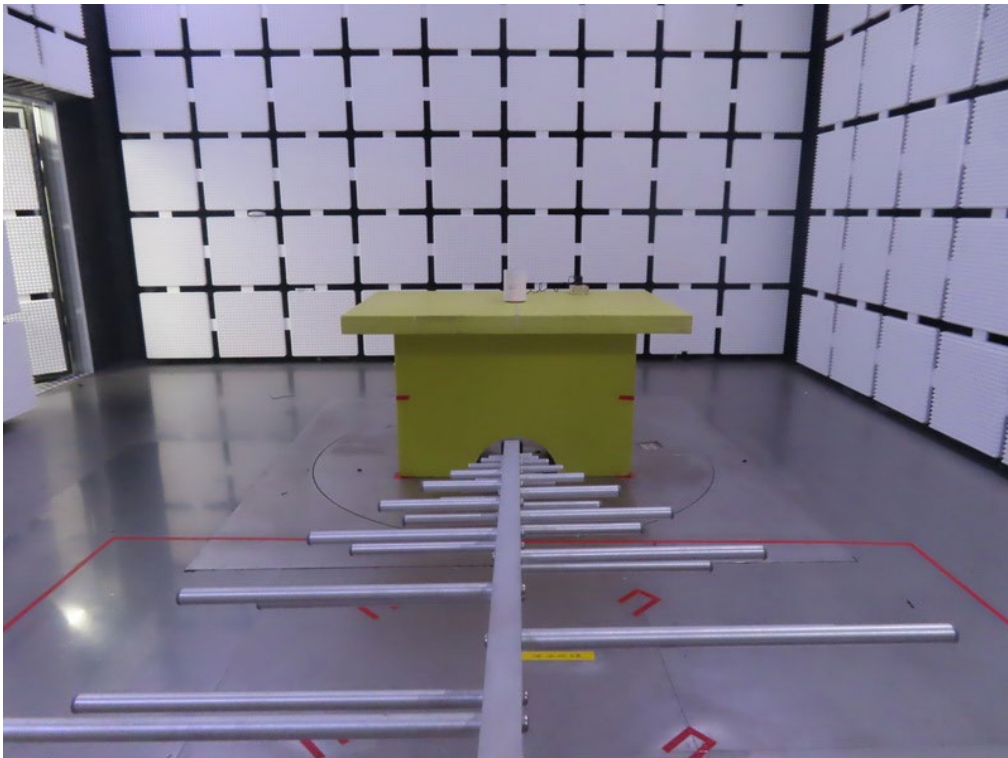
Radiated Emissions Test Photos**30 MHz to 1 GHz**

Radiated Emissions Test Photos
Band edge & Harmonic(1 GHz to 18 GHz)

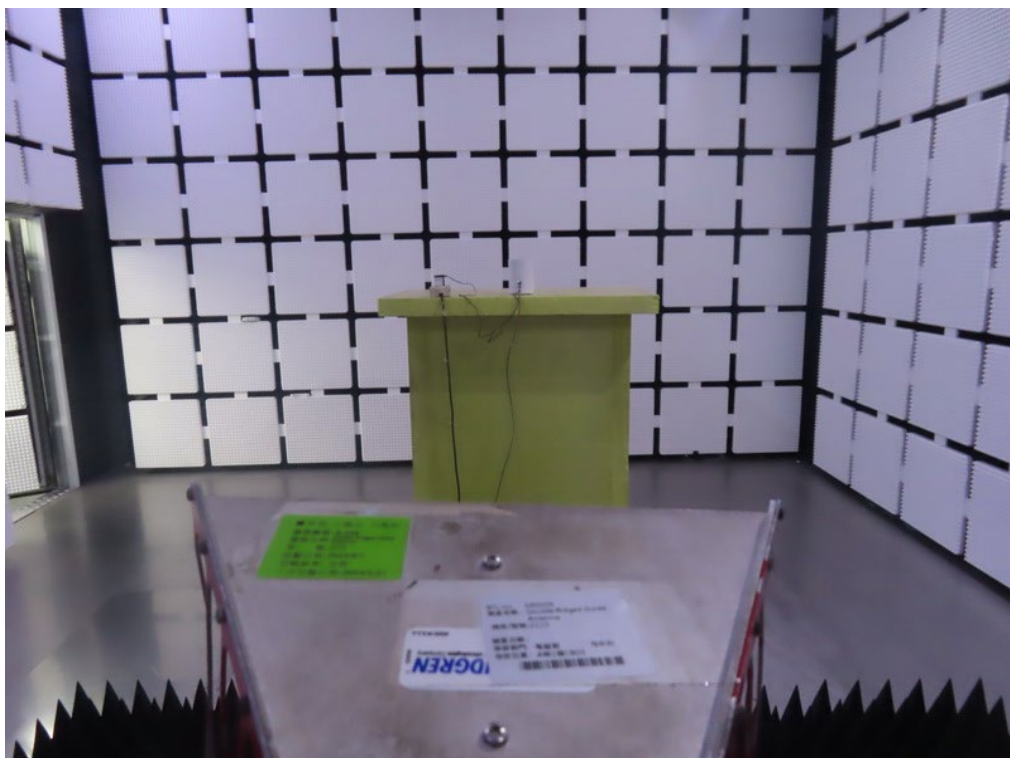
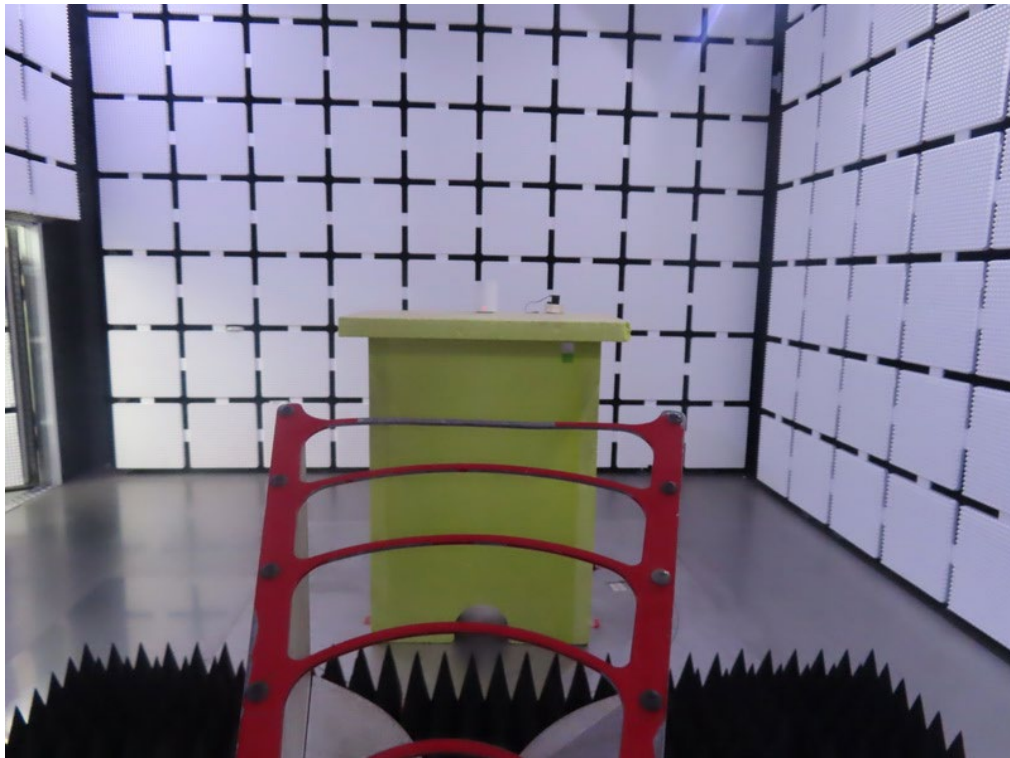

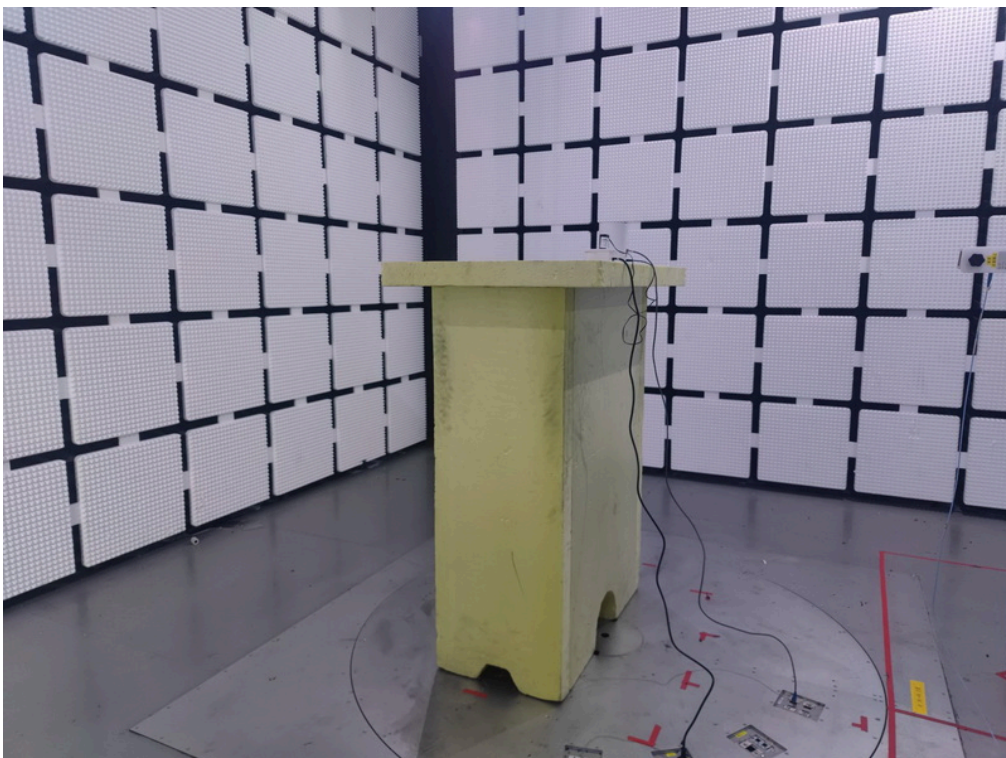
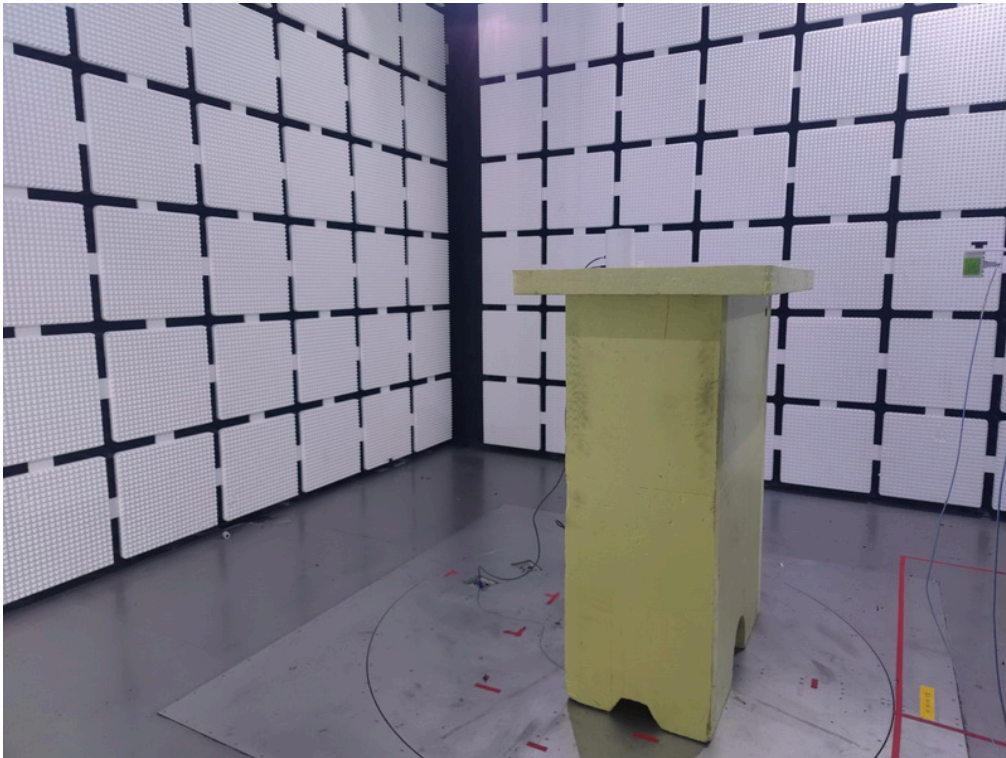
Radiated Emissions Test Photos**Harmonic(Above 18 GHz)**

Conducted Test Photos

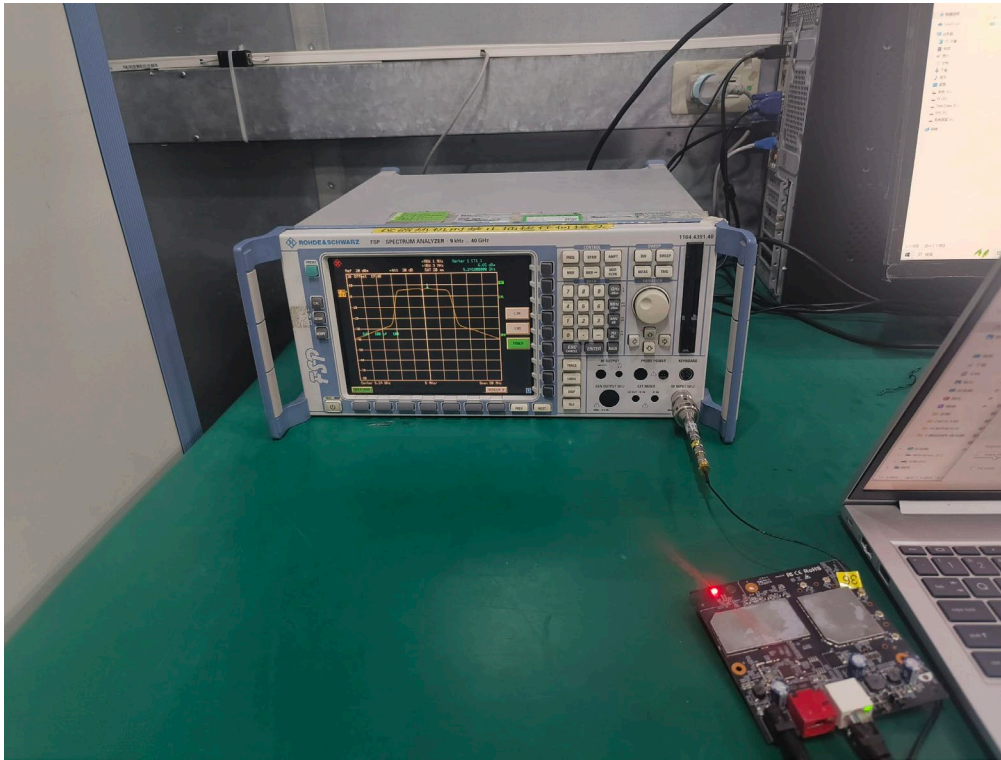

APPENDIX A - AC POWER LINE CONDUCTED EMISSIONS

Test Mode	TX AX(HE40) Mode Channel 38 (UNII-1)	Phase	Line
-----------	--------------------------------------	-------	------

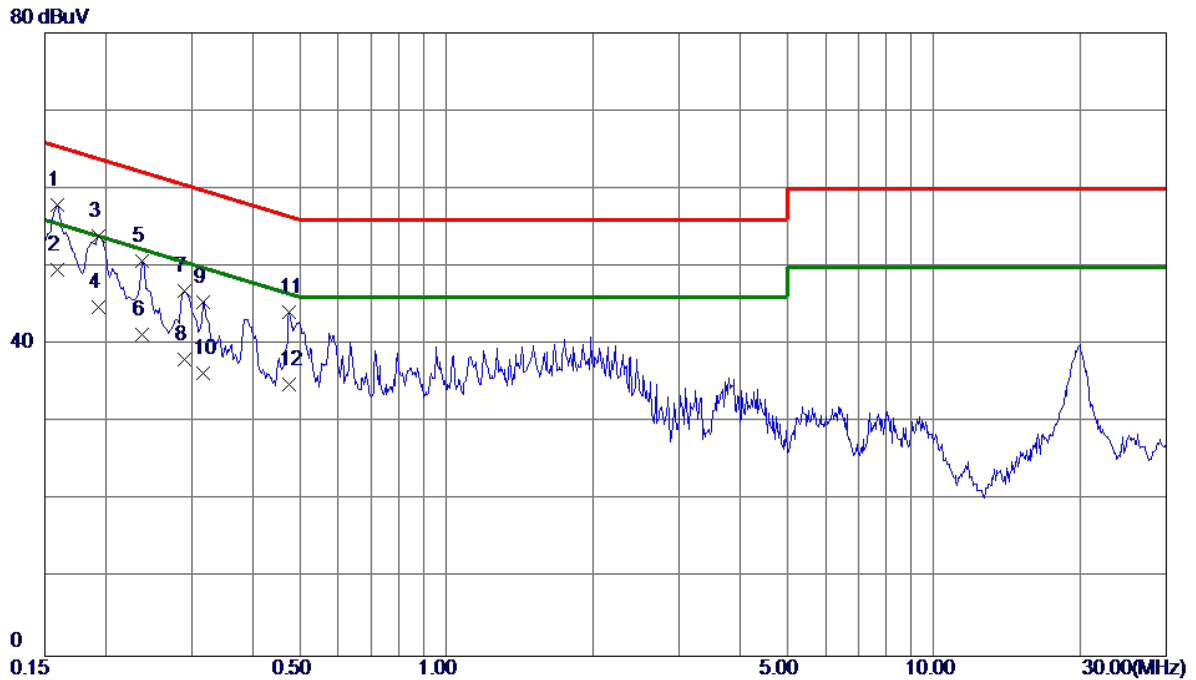

No.	Freq. MHz	Reading Level dBuV	Correct Factor dB	Measure ment dBuV	Limit dBuV	Margin dB	Detector	Comment
1	0.1590	48.01	9.97	57.98	65.52	-7.54	QP	
2 *	0.1590	39.60	9.97	49.57	55.52	-5.95	AVG	
3	0.1928	43.86	9.98	53.84	63.92	-10.08	QP	
4	0.1928	34.80	9.98	44.78	53.92	-9.14	AVG	
5	0.2378	40.71	10.04	50.75	62.17	-11.42	QP	
6	0.2378	31.20	10.04	41.24	52.17	-10.93	AVG	
7	0.2895	36.69	10.15	46.84	60.54	-13.70	QP	
8	0.2895	27.90	10.15	38.05	50.54	-12.49	AVG	
9	0.3165	35.28	10.21	45.49	59.80	-14.31	QP	
10	0.3165	26.10	10.21	36.31	49.80	-13.49	AVG	
11	0.4762	33.59	10.58	44.17	56.41	-12.24	QP	
12	0.4762	24.30	10.58	34.88	46.41	-11.53	AVG	

REMARKS:

- (1) Measurement Value = Reading Level + Correct Factor.
- (2) Margin Level = Measurement Value - Limit Value.

Test Mode	TX AX(HE40) Mode Channel 38 (UNII-1)	Phase	Neutral
-----------	--------------------------------------	-------	---------

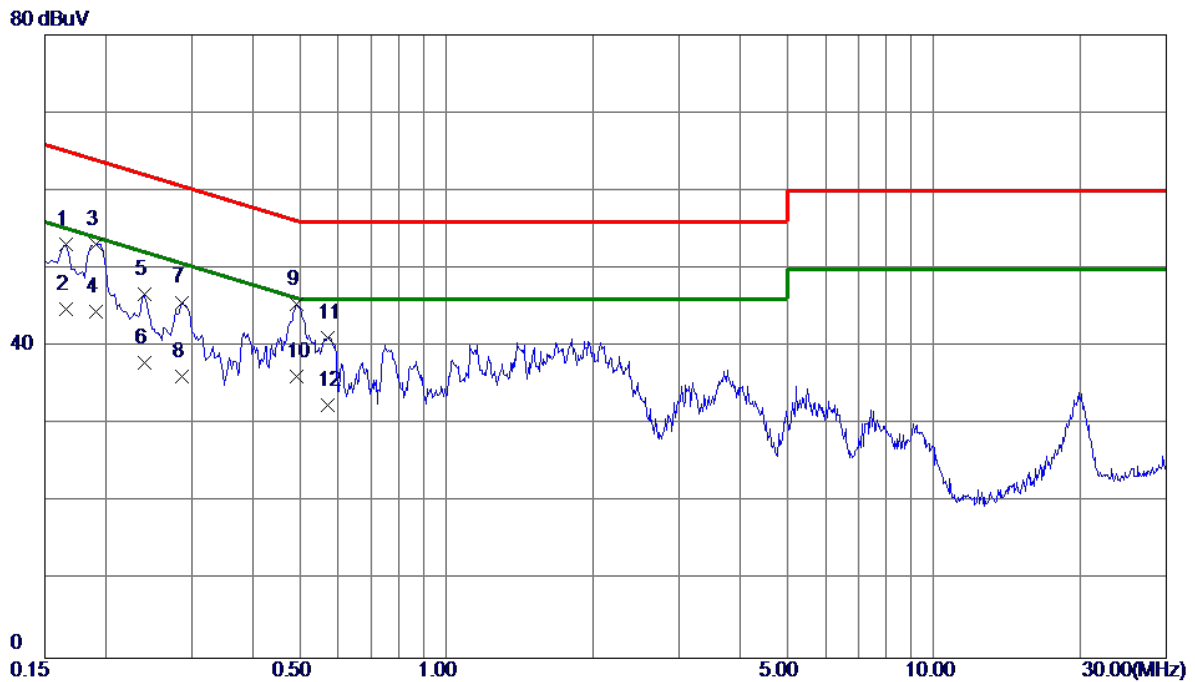

No.	Freq. MHz	Reading Level dBuV	Correct Factor dB	Measure ment dBuV	Limit dBuV	Margin dB	Detector	Comment
1	0.1658	43.17	9.93	53.10	65.17	-12.07	QP	
2	0.1658	34.80	9.93	44.73	55.17	-10.44	AVG	
3	0.1905	43.25	9.94	53.19	64.01	-10.82	QP	
4 *	0.1905	34.50	9.94	44.44	54.01	-9.57	AVG	
5	0.2400	36.77	10.01	46.78	62.10	-15.32	QP	
6	0.2400	27.89	10.01	37.90	52.10	-14.20	AVG	
7	0.2872	35.58	10.10	45.68	60.60	-14.92	QP	
8	0.2872	26.10	10.10	36.20	50.60	-14.40	AVG	
9	0.4920	34.84	10.57	45.41	56.13	-10.72	QP	
10	0.4920	25.60	10.57	36.17	46.13	-9.96	AVG	
11	0.5707	30.40	10.73	41.13	56.00	-14.87	QP	
12	0.5707	21.70	10.73	32.43	46.00	-13.57	AVG	

REMARKS:

- (1) Measurement Value = Reading Level + Correct Factor.
- (2) Margin Level = Measurement Value - Limit Value.

APPENDIX B - RADIATED EMISSION - 9 KHZ TO 30 MHZ

Test Mode	TX AX(HE40) Mode Channel 38 (UNII-1)	Polarization	Ant 0°
-----------	--------------------------------------	--------------	--------

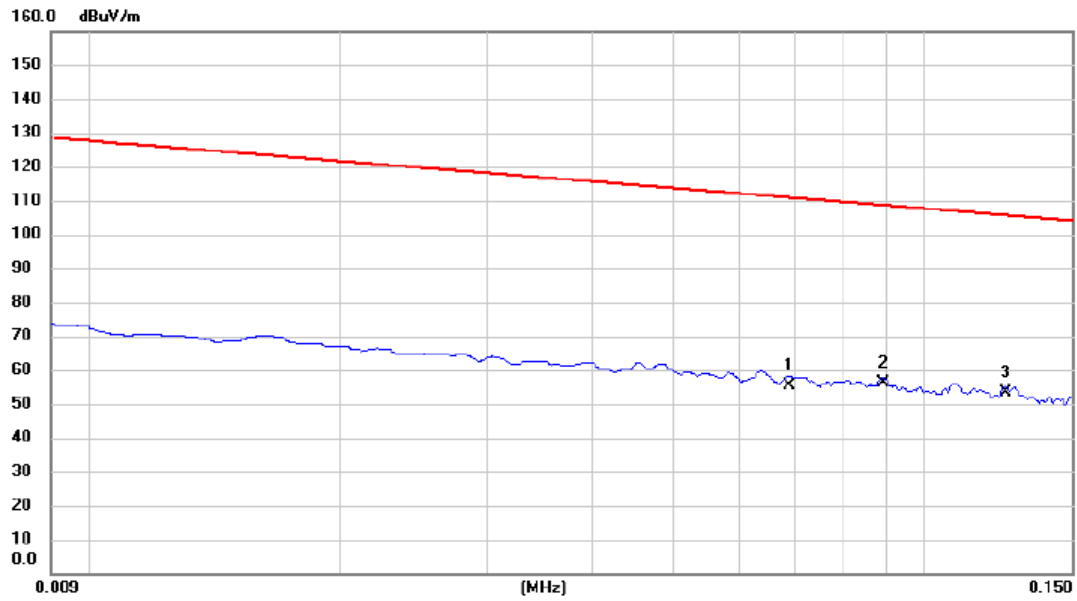

No. Mk.	Freq. MHz	Reading Level dBuV	Correct Factor dB	Measure- ment dBuV/m	Limit dBuV/m	Margin dB	Detector	Comment
1	0.0690	34.16	21.26	55.42	110.83	-55.41	AVG	
2 *	0.0892	34.98	21.30	56.28	108.60	-52.32	AVG	
3	0.1250	31.94	21.29	53.23	105.67	-52.44	QP	

REMARKS:

- (1) Measurement Value = Reading Level + Correct Factor.
- (2) Margin Level = Measurement Value - Limit Value.

Test Mode	TX AX(HE40) Mode Channel 38 (UNII-1)	Polarization	Ant 0°
-----------	--------------------------------------	--------------	--------

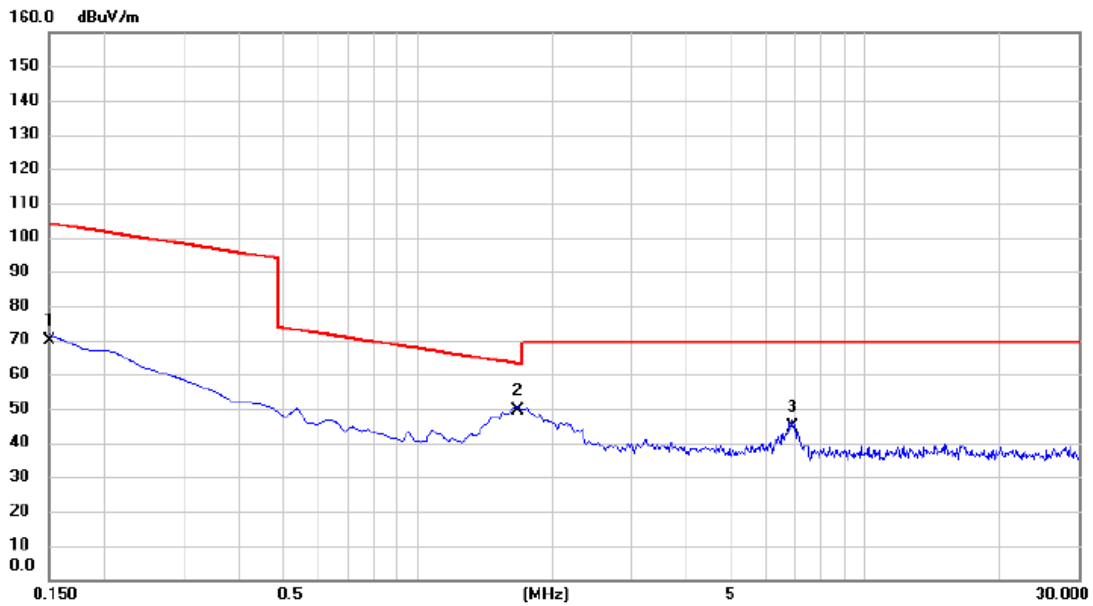

No.	Mk.	Freq. MHz	Reading Level dBuV	Correct Factor dB	Measure- ment dBuV/m	Limit dBuV/m	Margin dB	Detector	Comment
1		0.1500	48.65	21.26	69.91	104.09	-34.18	AVG	
2	*	1.6724	28.15	21.11	49.26	63.14	-13.88	QP	
3		6.8662	23.61	21.17	44.78	69.54	-24.76	QP	

REMARKS:

- (1) Measurement Value = Reading Level + Correct Factor.
- (2) Margin Level = Measurement Value - Limit Value.

Test Mode	TX AX(HE40) Mode Channel 38 (UNII-1)	Polarization	Ant 90°
-----------	--------------------------------------	--------------	---------

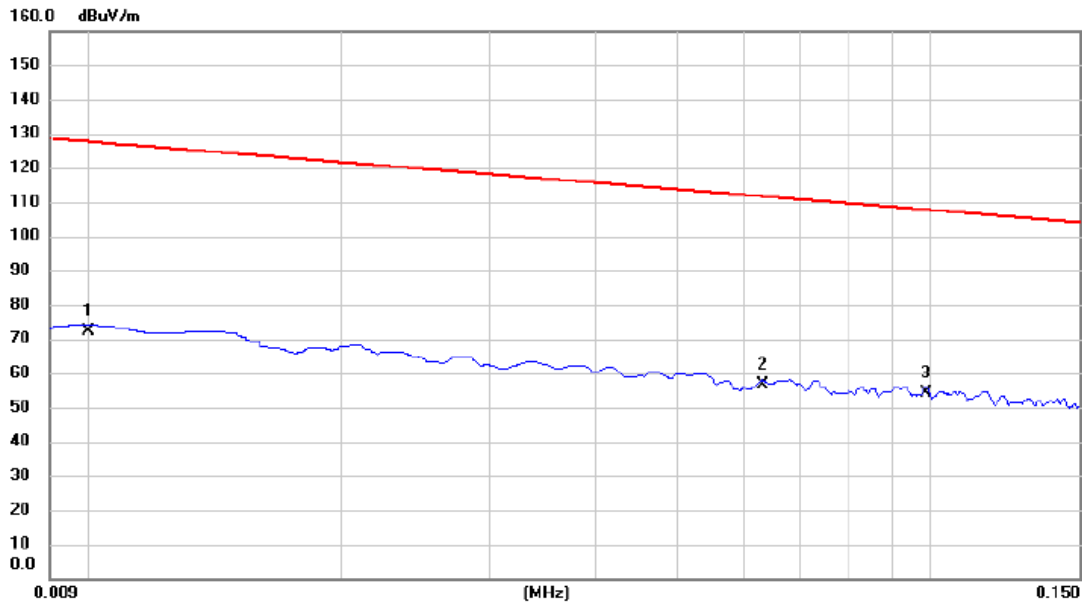

No.	Mk.	Freq.	Reading Level	Correct Factor	Measurement	Limit	Margin		
		MHz	dBuV	dB	dBuV/m	dBuV/m	dB	Detector	Comment
1		0.0100	51.68	20.50	72.18	127.60	-55.42	AVG	
2		0.0631	35.47	21.24	56.71	111.60	-54.89	AVG	
3	*	0.0988	32.84	21.33	54.17	107.71	-53.54	QP	

REMARKS:

- (1) Measurement Value = Reading Level + Correct Factor.
- (2) Margin Level = Measurement Value - Limit Value.

Test Mode	TX AX(HE40) Mode Channel 38 (UNII-1)	Polarization	Ant 90°
-----------	--------------------------------------	--------------	---------

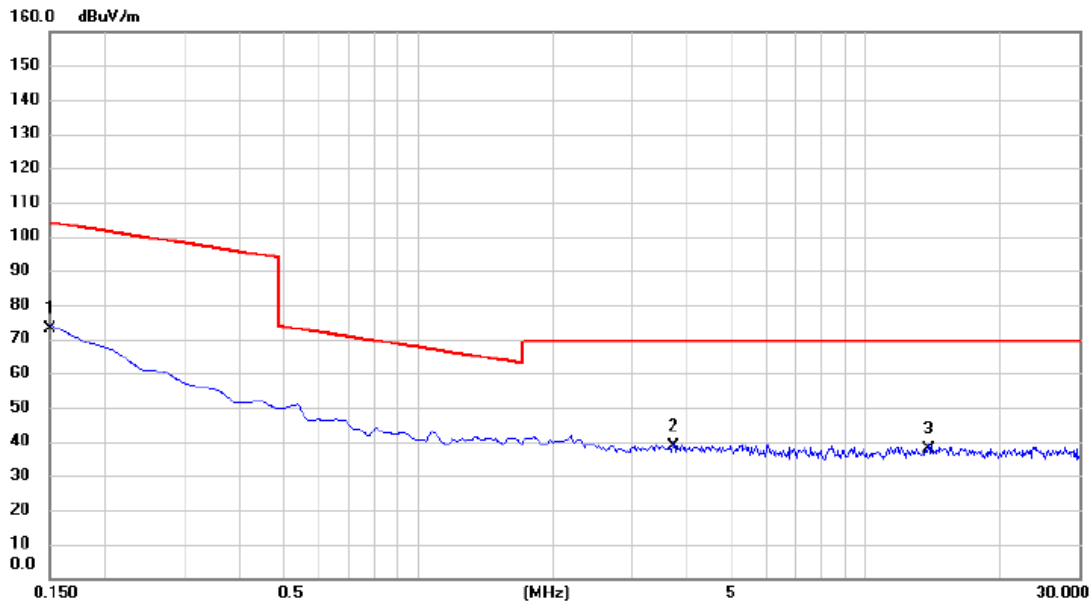

No.	Mk.	Freq. MHz	Reading Level dBuV	Correct Factor dB	Measure- ment dBuV/m	Limit dBuV/m	Margin dB	Detector	Comment
1		0.1500	51.68	21.26	72.94	104.09	-31.15	AVG	
2	*	3.7320	17.36	21.13	38.49	69.54	-31.05	QP	
3		13.8810	16.57	21.24	37.81	69.54	-31.73	QP	

REMARKS:

- (1) Measurement Value = Reading Level + Correct Factor.
- (2) Margin Level = Measurement Value - Limit Value.

APPENDIX C - RADIATED EMISSION - 30 MHZ TO 1000 MHZ

Test Mode	TX AX(HE40) Mode Channel 38 (UNII-1)	Polarization	Vertical
-----------	--------------------------------------	--------------	----------

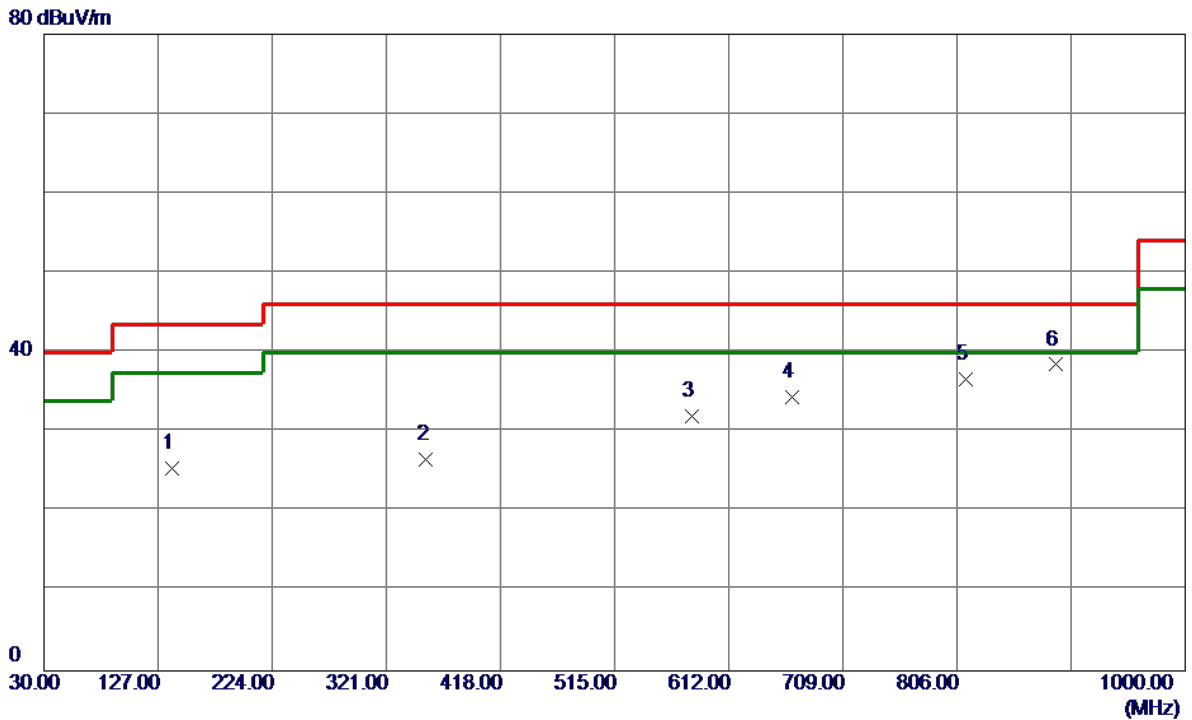

No.	Freq. MHz	Reading Level dBuV/m	Correct Factor dB	Measure ment dBuV/m	Limit dBuV/m	Margin dB	Detector	Comment
1	139.1250	37.19	-11.81	25.38	43.50	-18.12	Peak	
2	354.9500	36.04	-9.50	26.54	46.00	-19.46	Peak	
3	580.4750	36.30	-4.28	32.02	46.00	-13.98	Peak	
4	665.8350	37.24	-2.82	34.42	46.00	-11.58	Peak	
5	813.7600	37.83	-1.19	36.64	46.00	-9.36	Peak	
6 *	889.9050	38.49	-0.01	38.48	46.00	-7.52	Peak	

REMARKS:

- (1) Measurement Value = Reading Level + Correct Factor.
- (2) Margin Level = Measurement Value - Limit Value.

Test Mode	TX AX(HE40) Mode Channel 38 (UNII-1)	Polarization	Horizontal
-----------	--------------------------------------	--------------	------------

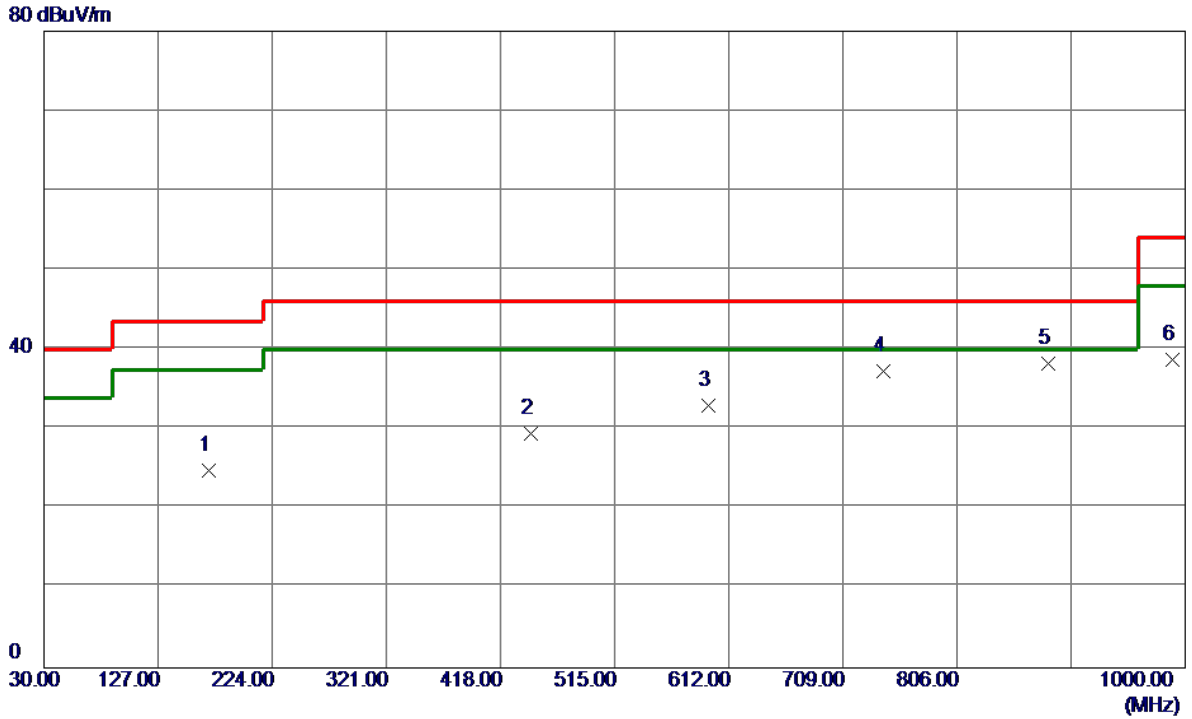

No.	Freq. MHz	Reading Level dBuV/m	Correct Factor dB	Measurement dBuV/m	Limit dBuV/m	Margin dB	Detector	Comment
1	170.1649	36.06	-11.33	24.73	43.50	-18.77	Peak	
2	444.1900	36.48	-7.01	29.47	46.00	-16.53	Peak	
3	594.5400	36.80	-3.90	32.90	46.00	-13.10	Peak	
4	742.9500	38.62	-1.41	37.21	46.00	-8.79	Peak	
5 *	884.0850	38.32	-0.10	38.22	46.00	-7.78	Peak	
6	988.8450	38.04	0.68	38.72	54.00	-15.28	Peak	

REMARKS:

- (1) Measurement Value = Reading Level + Correct Factor.
- (2) Margin Level = Measurement Value - Limit Value.

APPENDIX D - RADIATED EMISSION - ABOVE 1000 MHZ

Test Mode	UNII-1_TX A Mode 5180 MHz	Polarization	Vertical
-----------	---------------------------	--------------	----------

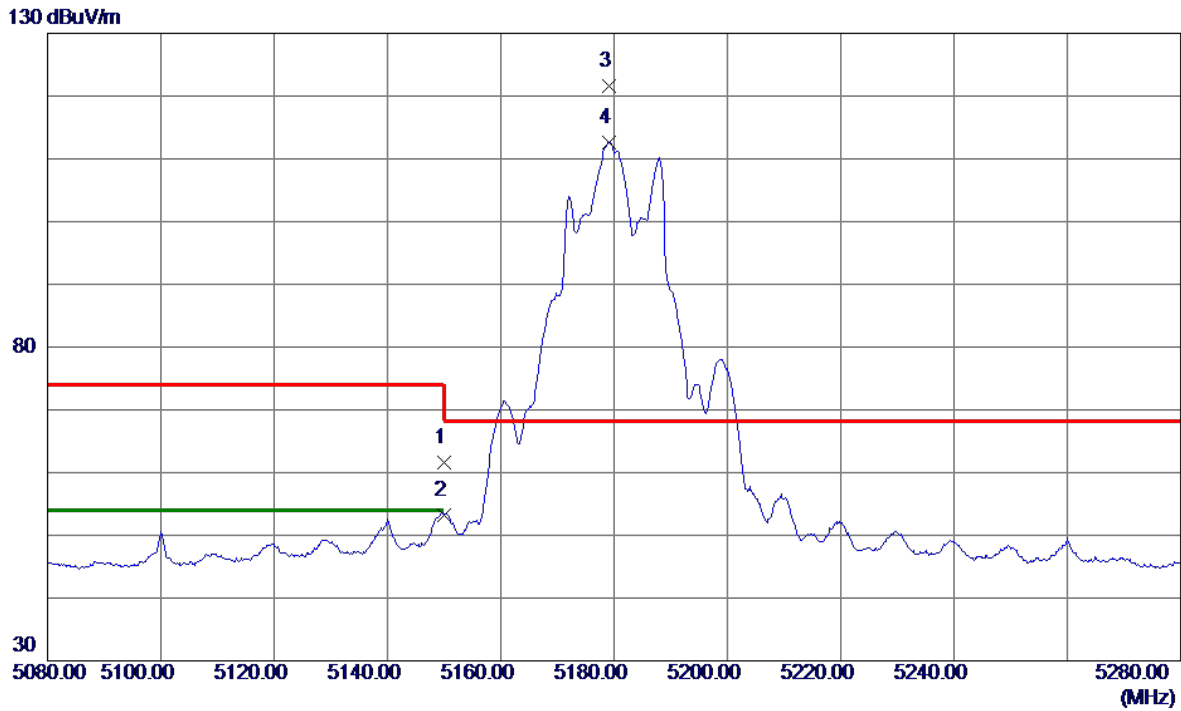

No.	Freq. MHz	Reading Level dBuV/m	Correct Factor dB	Measure ment dBuV/m	Limit dBuV/m	Margin dB	Detector	Comment
1	5150.0000	49.97	11.54	61.51	74.00	-12.49	Peak	
2	5150.0000	41.74	11.54	53.28	54.00	-0.72	AVG	
3 *	5179.1000	110.05	11.60	121.65	68.20	53.45	Peak	No Limit
4	5179.2000	101.07	11.60	112.67	999.00	-886.33	AVG	No Limit

REMARKS:

- (1) Measurement Value = Reading Level + Correct Factor.
- (2) Margin Level = Measurement Value - Limit Value.

Test Mode	UNII-1_TX A Mode 5180 MHz	Polarization	Horizontal
-----------	---------------------------	--------------	------------

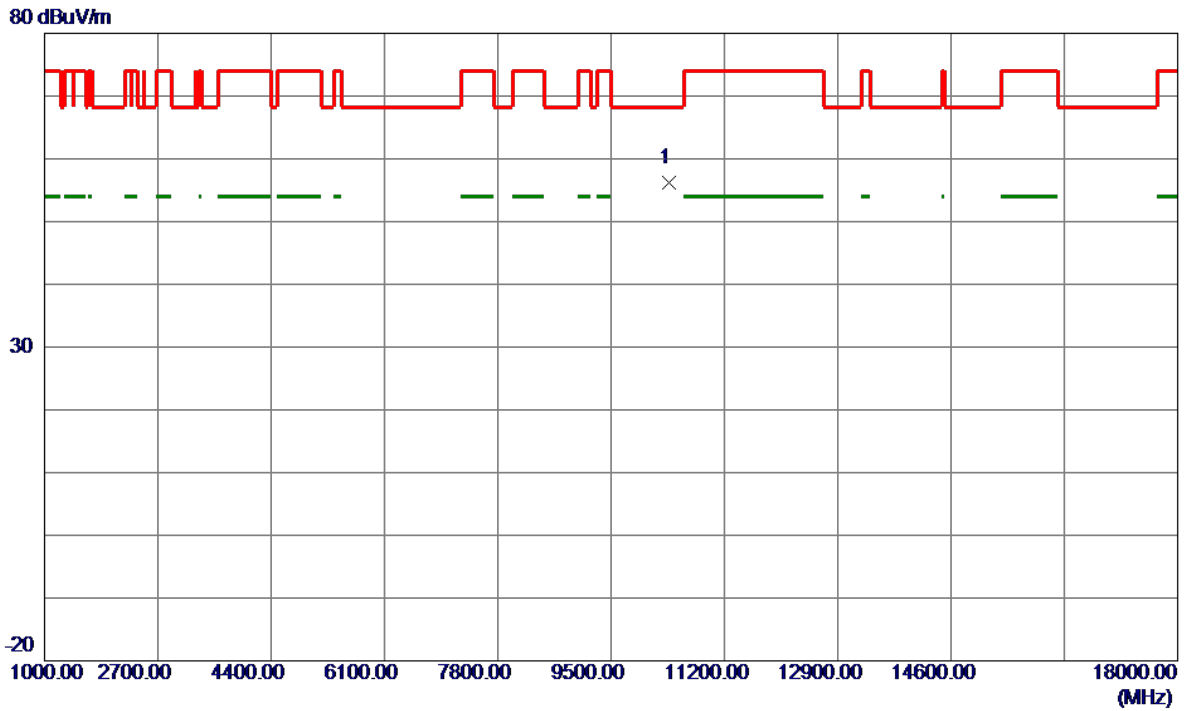

No.	Freq. MHz	Reading Level dBuV/m	Correct Factor dB	Measure ment dBuV/m	Limit dBuV/m	Margin dB	Detector	Comment
1 *	10362.5500	48.61	7.53	56.14	68.20	-12.06	Peak	

REMARKS:

- (1) Measurement Value = Reading Level + Correct Factor.
- (2) Margin Level = Measurement Value - Limit Value.

Test Mode	UNII-1_TX A Mode 5200 MHz	Polarization	Vertical
-----------	---------------------------	--------------	----------

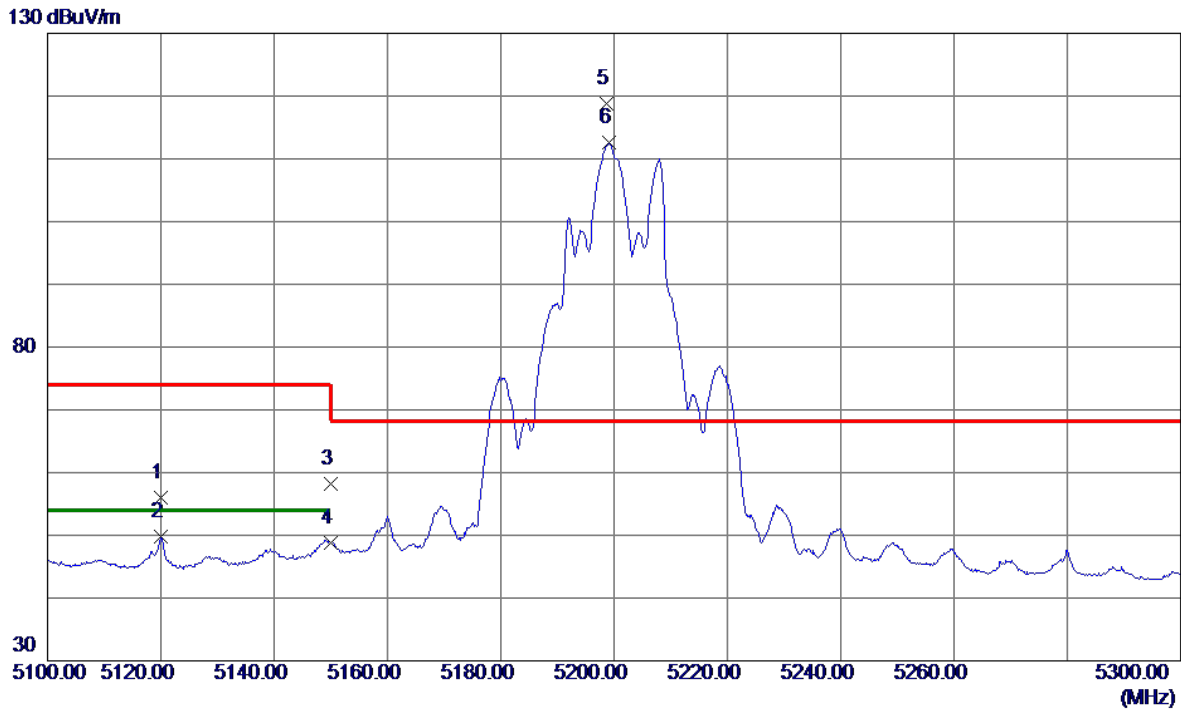

No.	Freq. MHz	Reading Level dBuV/m	Correct Factor dB	Measure ment dBuV/m	Limit dBuV/m	Margin dB	Detector	Comment
1	5120.0000	44.44	11.47	55.91	74.00	-18.09	Peak	
2	5120.0000	38.30	11.47	49.77	54.00	-4.23	AVG	
3	5150.0000	46.61	11.54	58.15	74.00	-15.85	Peak	
4	5150.0000	37.20	11.54	48.74	54.00	-5.26	AVG	
5 *	5198.7000	107.11	11.64	118.75	68.20	50.55	Peak	No Limit
6	5199.2000	100.89	11.64	112.53	999.00	-886.47	AVG	No Limit

REMARKS:

- (1) Measurement Value = Reading Level + Correct Factor.
- (2) Margin Level = Measurement Value - Limit Value.

Test Mode	UNII-1_TX A Mode 5200 MHz	Polarization	Horizontal
-----------	---------------------------	--------------	------------

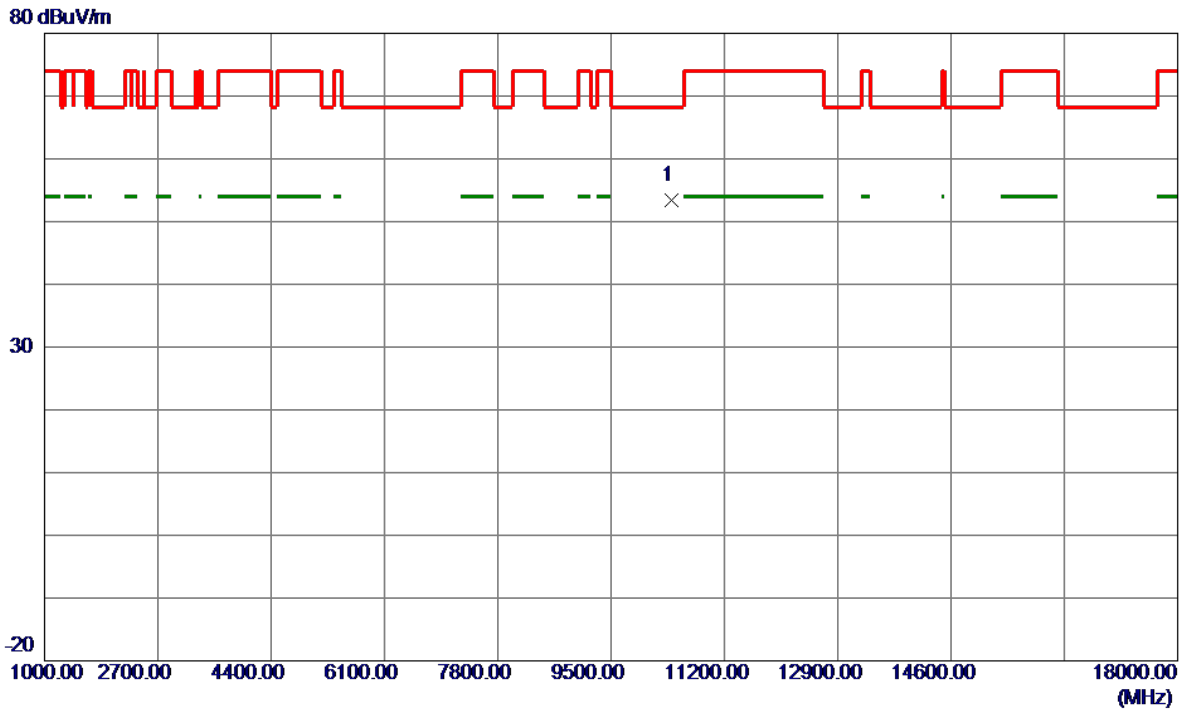

No.	Freq. MHz	Reading Level dBuV/m	Correct Factor dB	Measure ment dBuV/m	Limit dBuV/m	Margin dB	Detector	Comment
1 *	10402.4000	45.91	7.56	53.47	68.20	-14.73	Peak	

REMARKS:

- (1) Measurement Value = Reading Level + Correct Factor.
- (2) Margin Level = Measurement Value - Limit Value.

Test Mode	UNII-1_TX A Mode 5240 MHz	Polarization	Horizontal
-----------	---------------------------	--------------	------------

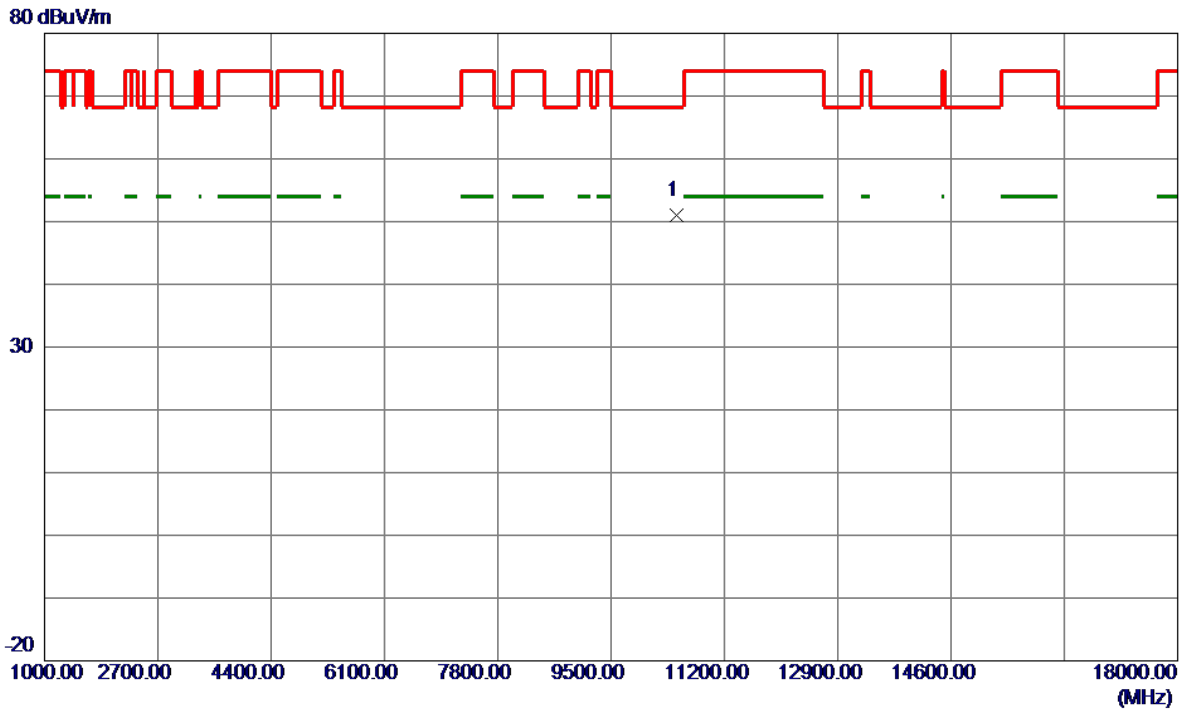

No.	Freq. MHz	Reading Level dBuV/m	Correct Factor dB	Measure ment dBuV/m	Limit dBuV/m	Margin dB	Detector	Comment
1 *	10482.4250	43.30	7.64	50.94	68.20	-17.26	Peak	

REMARKS:

- (1) Measurement Value = Reading Level + Correct Factor.
- (2) Margin Level = Measurement Value - Limit Value.

Test Mode	UNII-1_TX AC(VHT20) Mode 5180 MHz	Polarization	Vertical
-----------	-----------------------------------	--------------	----------

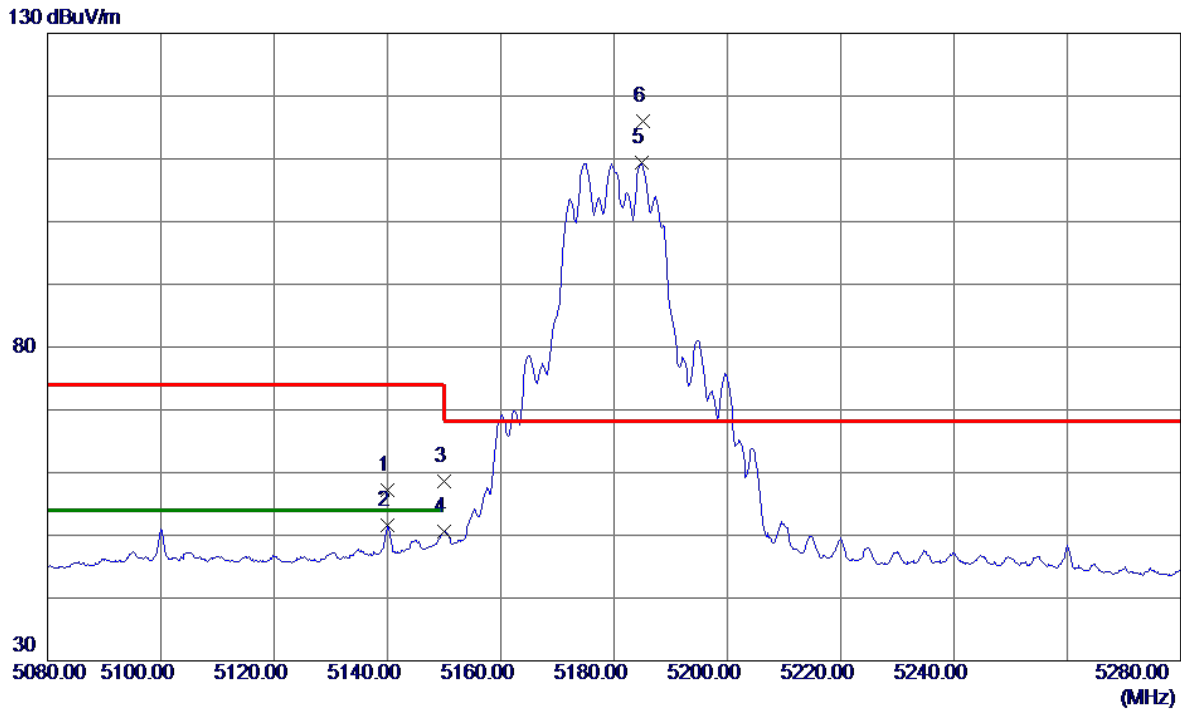

No.	Freq. MHz	Reading Level dBuV/m	Correct Factor dB	Measure ment dBuV/m	Limit dBuV/m	Margin dB	Detector	Comment
1	5140.0000	45.77	11.52	57.29	74.00	-16.71	Peak	
2	5140.0000	40.04	11.52	51.56	54.00	-2.44	AVG	
3	5150.0000	47.04	11.54	58.58	74.00	-15.42	Peak	
4	5150.0000	39.05	11.54	50.59	54.00	-3.41	AVG	
5	5184.9000	97.71	11.61	109.32	999.00	-889.68	AVG	No Limit
6 *	5185.1000	104.44	11.61	116.05	68.20	47.85	Peak	No Limit

REMARKS:

- (1) Measurement Value = Reading Level + Correct Factor.
- (2) Margin Level = Measurement Value - Limit Value.

Test Mode	UNII-1_TX AC(VHT20) Mode 5180 MHz	Polarization	Horizontal
-----------	-----------------------------------	--------------	------------

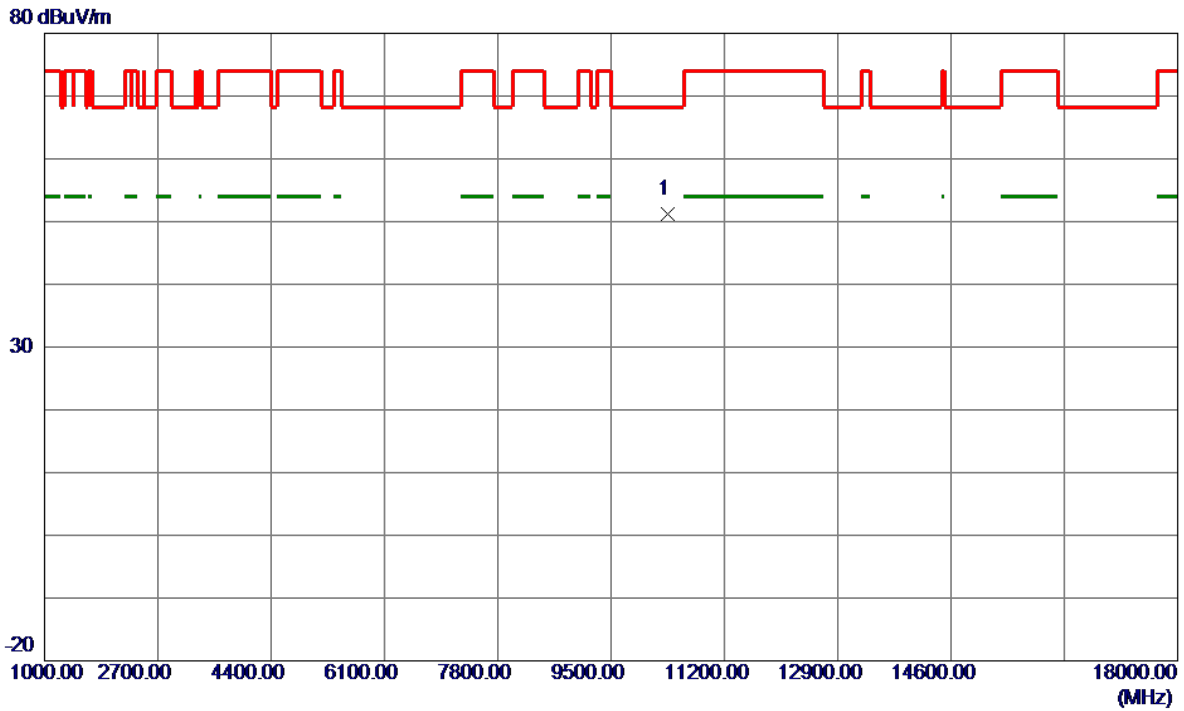

No.	Freq. MHz	Reading Level dBuV/m	Correct Factor dB	Measure ment dBuV/m	Limit dBuV/m	Margin dB	Detector	Comment
1 *	10358.4000	43.69	7.52	51.21	68.20	-16.99	Peak	

REMARKS:

- (1) Measurement Value = Reading Level + Correct Factor.
- (2) Margin Level = Measurement Value - Limit Value.

Test Mode	UNII-1_TX AC(VHT20) Mode 5200 MHz	Polarization	Vertical
-----------	-----------------------------------	--------------	----------

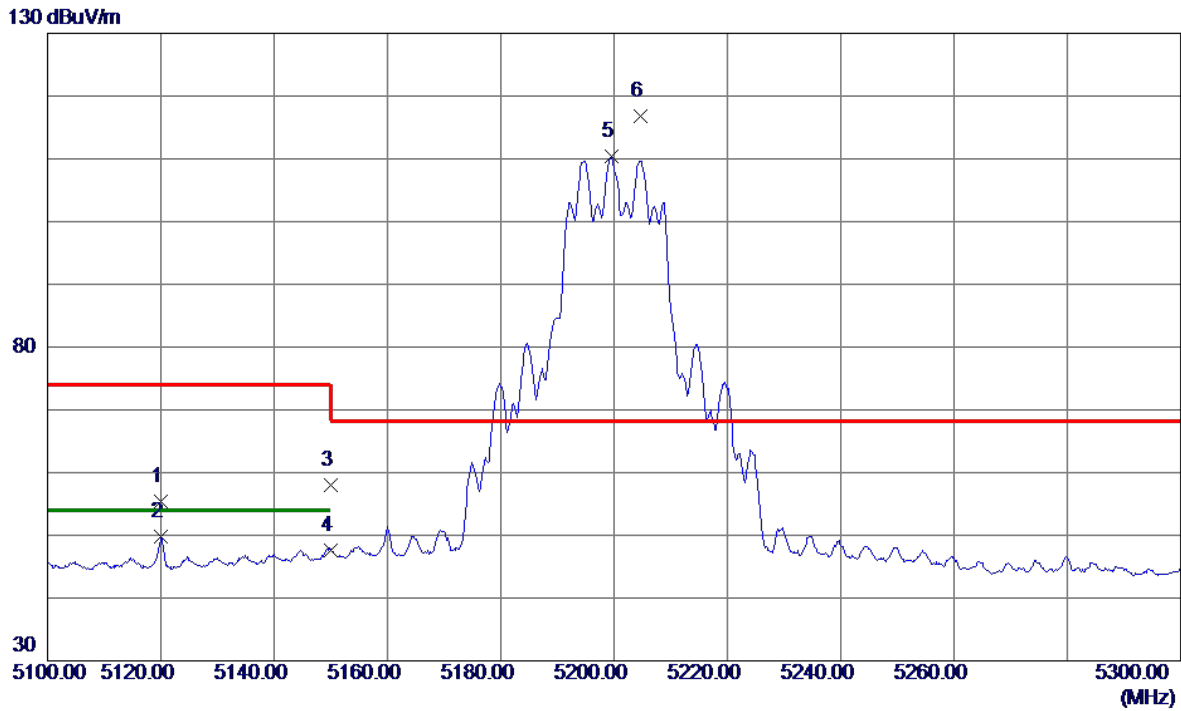

No.	Freq. MHz	Reading Level dBuV/m	Correct Factor dB	Measure ment dBuV/m	Limit dBuV/m	Margin dB	Detector	Comment
1	5120.0000	43.85	11.47	55.32	74.00	-18.68	Peak	
2	5120.1000	38.26	11.47	49.73	54.00	-4.27	AVG	
3	5150.0000	46.46	11.54	58.00	74.00	-16.00	Peak	
4	5150.0000	36.12	11.54	47.66	54.00	-6.34	AVG	
5	5199.5000	98.80	11.64	110.44	999.00	-888.56	AVG	No Limit
6 *	5204.6000	105.07	11.65	116.72	68.20	48.52	Peak	No Limit

REMARKS:

- (1) Measurement Value = Reading Level + Correct Factor.
- (2) Margin Level = Measurement Value - Limit Value.

Test Mode	UNII-1_TX AC(VHT20) Mode 5200 MHz	Polarization	Horizontal
-----------	-----------------------------------	--------------	------------

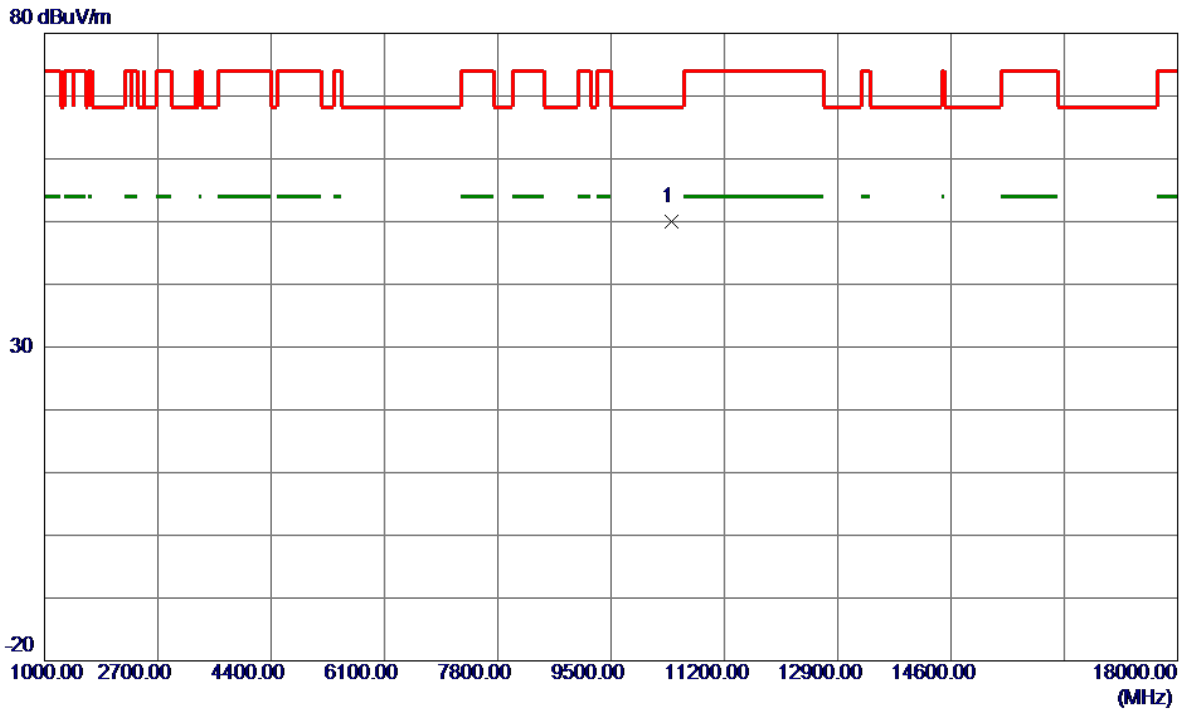

No.	Freq. MHz	Reading Level dBuV/m	Correct Factor dB	Measure ment dBuV/m	Limit dBuV/m	Margin dB	Detector	Comment
1 *	10402.7750	42.35	7.56	49.91	68.20	-18.29	Peak	

REMARKS:

- (1) Measurement Value = Reading Level + Correct Factor.
- (2) Margin Level = Measurement Value - Limit Value.

Test Mode	UNII-1_TX AC(VHT20) Mode 5240 MHz	Polarization	Horizontal
-----------	-----------------------------------	--------------	------------

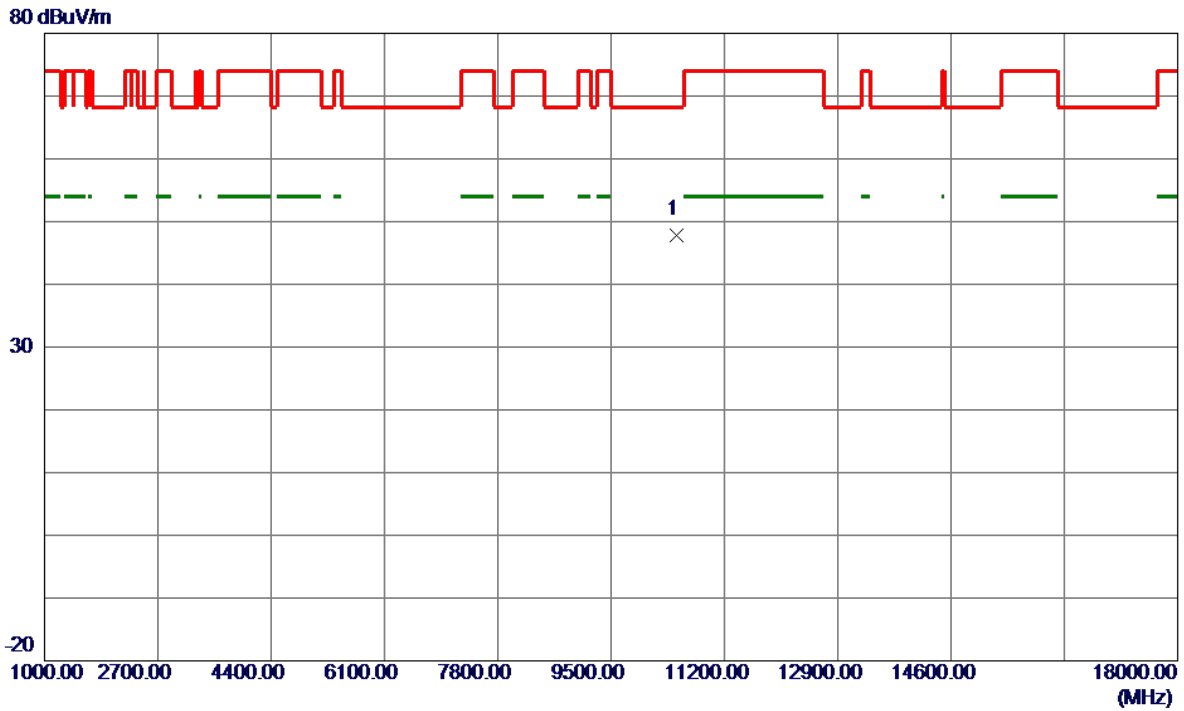

No.	Freq. MHz	Reading Level dBuV/m	Correct Factor dB	Measure ment dBuV/m	Limit dBuV/m	Margin dB	Detector	Comment
1 *	10479.1000	40.26	7.64	47.90	68.20	-20.30	Peak	

REMARKS:

- (1) Measurement Value = Reading Level + Correct Factor.
- (2) Margin Level = Measurement Value - Limit Value.

Test Mode	UNII-1_TX AC(VHT40) Mode 5190 MHz	Polarization	Vertical
-----------	-----------------------------------	--------------	----------

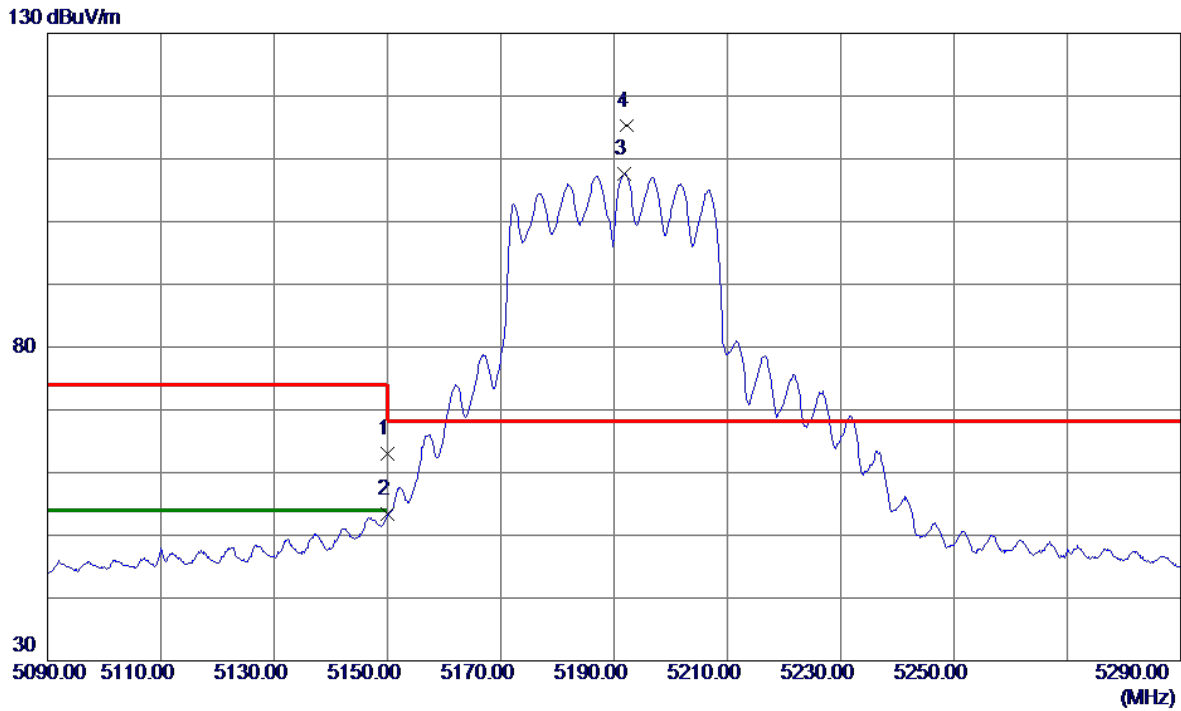

No.	Freq. MHz	Reading Level dBuV/m	Correct Factor dB	Measure ment dBuV/m	Limit dBuV/m	Margin dB	Detector	Comment
1	5150.0000	51.45	11.54	62.99	74.00	-11.01	Peak	
2	5150.0000	41.80	11.54	53.34	54.00	-0.66	AVG	
3	5191.7000	95.95	11.62	107.57	999.00	-891.43	AVG	No Limit
4 *	5192.3000	103.67	11.63	115.30	68.20	47.10	Peak	No Limit

REMARKS:

- (1) Measurement Value = Reading Level + Correct Factor.
- (2) Margin Level = Measurement Value - Limit Value.

Test Mode	UNII-1_TX AC(VHT40) Mode 5190 MHz	Polarization	Horizontal
-----------	-----------------------------------	--------------	------------

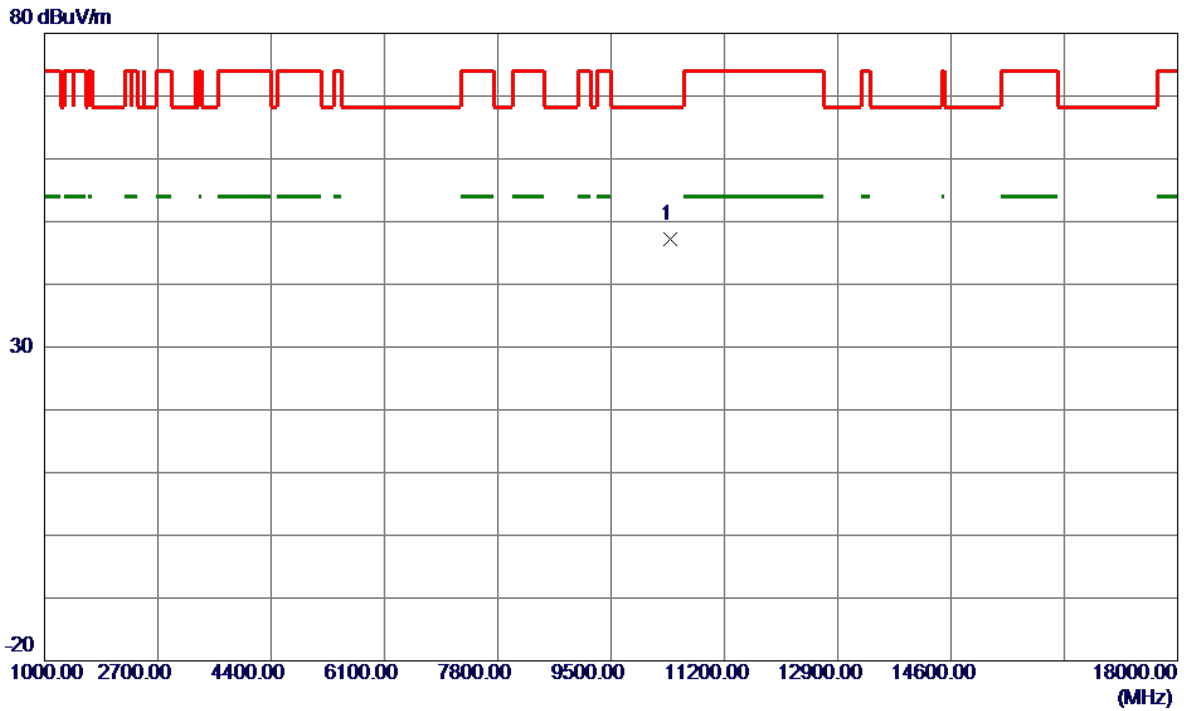

No.	Freq. MHz	Reading Level dBuV/m	Correct Factor dB	Measure ment dBuV/m	Limit dBuV/m	Margin dB	Detector	Comment
1 *	10383.3250	39.72	7.55	47.27	68.20	-20.93	Peak	

REMARKS:

- (1) Measurement Value = Reading Level + Correct Factor.
- (2) Margin Level = Measurement Value - Limit Value.

Test Mode	UNII-1_TX AC(VHT40) Mode 5230 MHz	Polarization	Vertical
-----------	-----------------------------------	--------------	----------

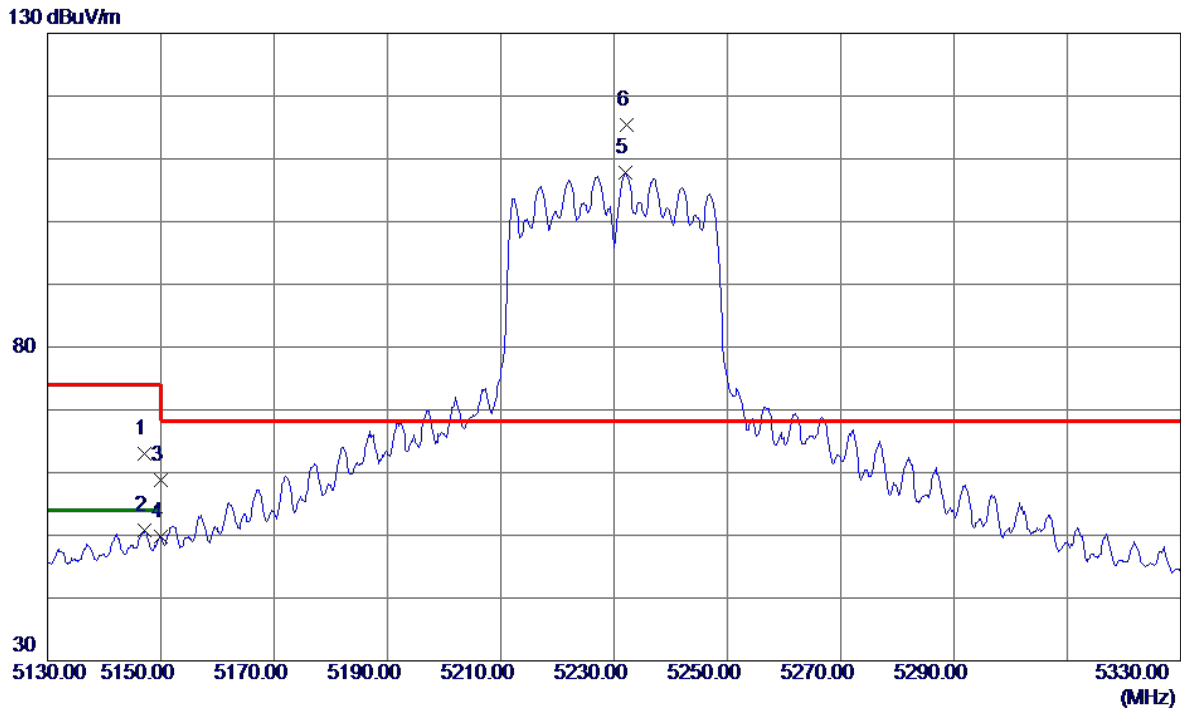

No.	Freq. MHz	Reading Level dBuV/m	Correct Factor dB	Measure ment dBuV/m	Limit dBuV/m	Margin dB	Detector	Comment
1	5147.2000	51.50	11.53	63.03	74.00	-10.97	Peak	
2	5147.2000	39.20	11.53	50.73	54.00	-3.27	AVG	
3	5150.0000	47.31	11.54	58.85	74.00	-15.15	Peak	
4	5150.0000	38.21	11.54	49.75	54.00	-4.25	AVG	
5	5231.9000	96.16	11.71	107.87	999.00	-891.13	AVG	No Limit
6 *	5232.2000	103.68	11.71	115.39	68.20	47.19	Peak	No Limit

REMARKS:

- (1) Measurement Value = Reading Level + Correct Factor.
- (2) Margin Level = Measurement Value - Limit Value.

Test Mode	UNII-1_TX AC(VHT40) Mode 5230 MHz	Polarization	Horizontal
-----------	-----------------------------------	--------------	------------

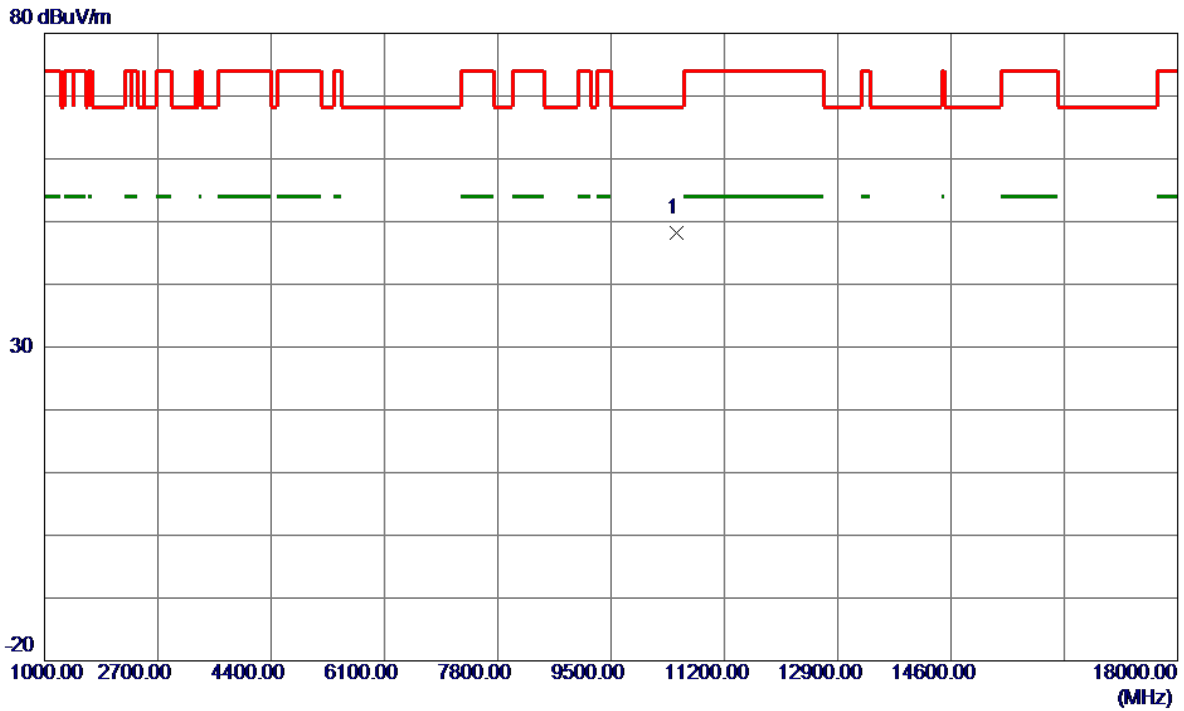

No.	Freq. MHz	Reading Level dBuV/m	Correct Factor dB	Measure ment dBuV/m	Limit dBuV/m	Margin dB	Detector	Comment
1 *	10473.6500	40.54	7.63	48.17	68.20	-20.03	Peak	

REMARKS:

- (1) Measurement Value = Reading Level + Correct Factor.
- (2) Margin Level = Measurement Value - Limit Value.

Test Mode	UNII-1_TX AC(VHT80) Mode 5210 MHz	Polarization	Vertical
-----------	-----------------------------------	--------------	----------

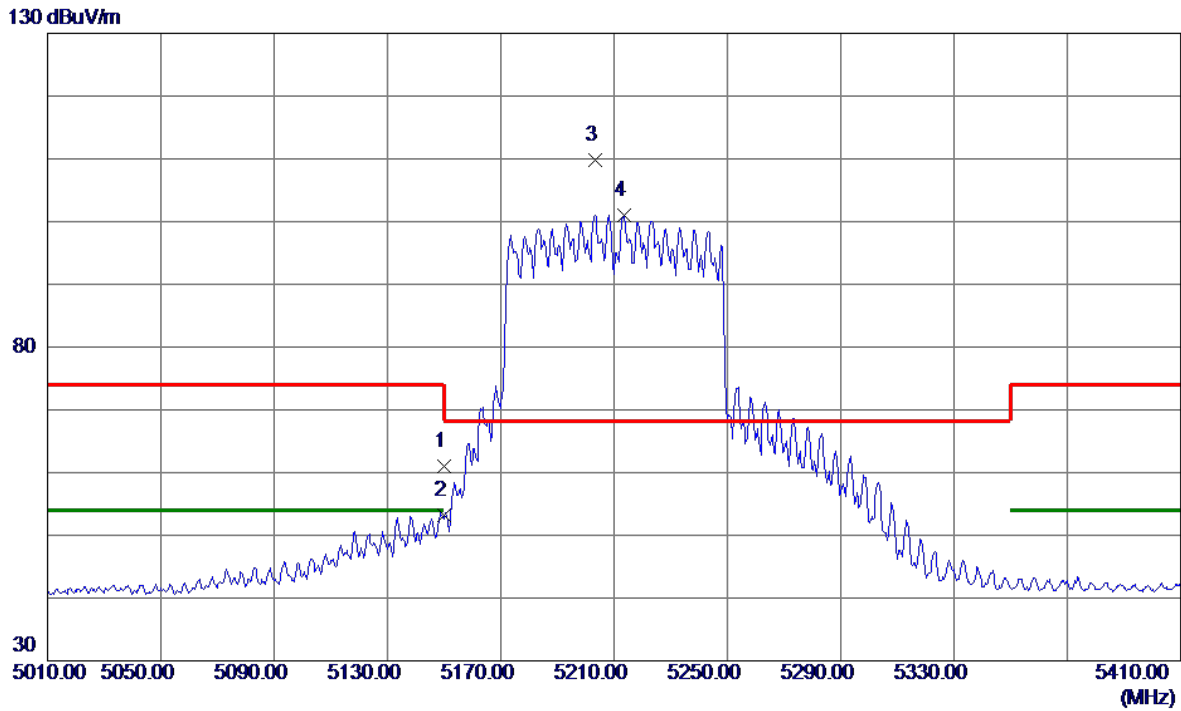

No.	Freq. MHz	Reading Level dBuV/m	Correct Factor dB	Measure ment dBuV/m	Limit dBuV/m	Margin dB	Detector	Comment
1	5150.0000	49.42	11.54	60.96	74.00	-13.04	Peak	
2	5150.0000	41.63	11.54	53.17	54.00	-0.83	AVG	
3 *	5203.2000	98.06	11.65	109.71	68.20	41.51	Peak	No Limit
4	5213.4000	89.39	11.67	101.06	999.00	-897.94	AVG	No Limit

REMARKS:

- (1) Measurement Value = Reading Level + Correct Factor.
- (2) Margin Level = Measurement Value - Limit Value.

Test Mode	UNII-1_TX AC(VHT80) Mode 5210 MHz	Polarization	Horizontal
-----------	-----------------------------------	--------------	------------

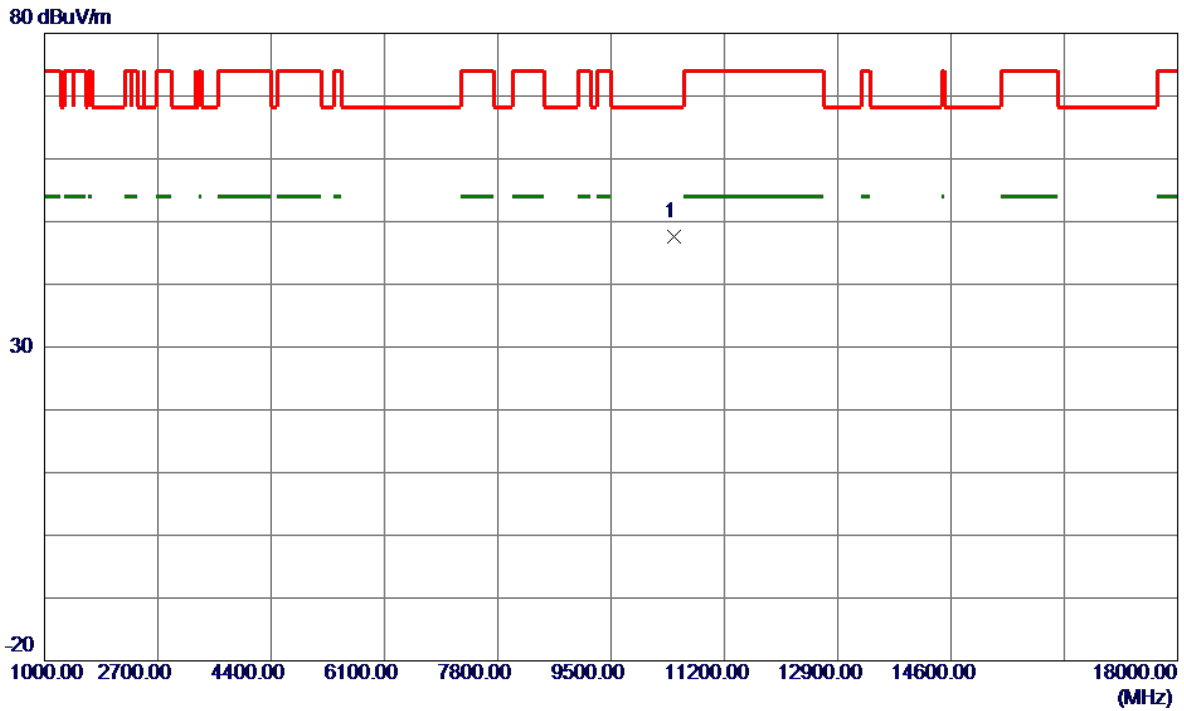

No.	Freq. MHz	Reading Level dBuV/m	Correct Factor dB	Measure ment dBuV/m	Limit dBuV/m	Margin dB	Detector	Comment
1 *	10442.6000	39.95	7.60	47.55	68.20	-20.65	Peak	

REMARKS:

- (1) Measurement Value = Reading Level + Correct Factor.
- (2) Margin Level = Measurement Value - Limit Value.

Test Mode	UNII-1_TX AX(HE20) Mode 5180 MHz	Polarization	Vertical
-----------	----------------------------------	--------------	----------

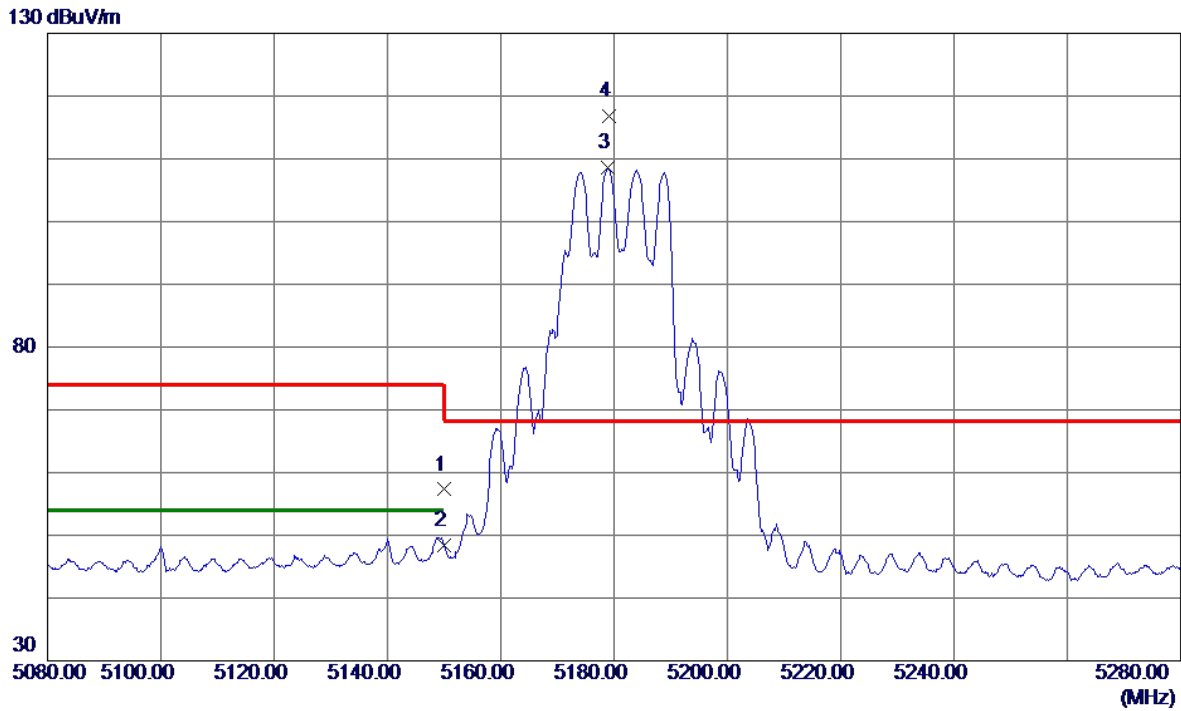

No.	Freq. MHz	Reading Level dBuV/m	Correct Factor dB	Measure ment dBuV/m	Limit dBuV/m	Margin dB	Detector	Comment
1	5150.0000	45.76	11.54	57.30	74.00	-16.70	Peak	
2	5150.0000	36.88	11.54	48.42	54.00	-5.58	AVG	
3	5178.9000	96.94	11.60	108.54	999.00	-890.46	AVG	No Limit
4 *	5179.1000	105.12	11.60	116.72	68.20	48.52	Peak	No Limit

REMARKS:

- (1) Measurement Value = Reading Level + Correct Factor.
- (2) Margin Level = Measurement Value - Limit Value.

Test Mode	UNII-1_TX AX(HE20) Mode 5180 MHz	Polarization	Horizontal
-----------	----------------------------------	--------------	------------

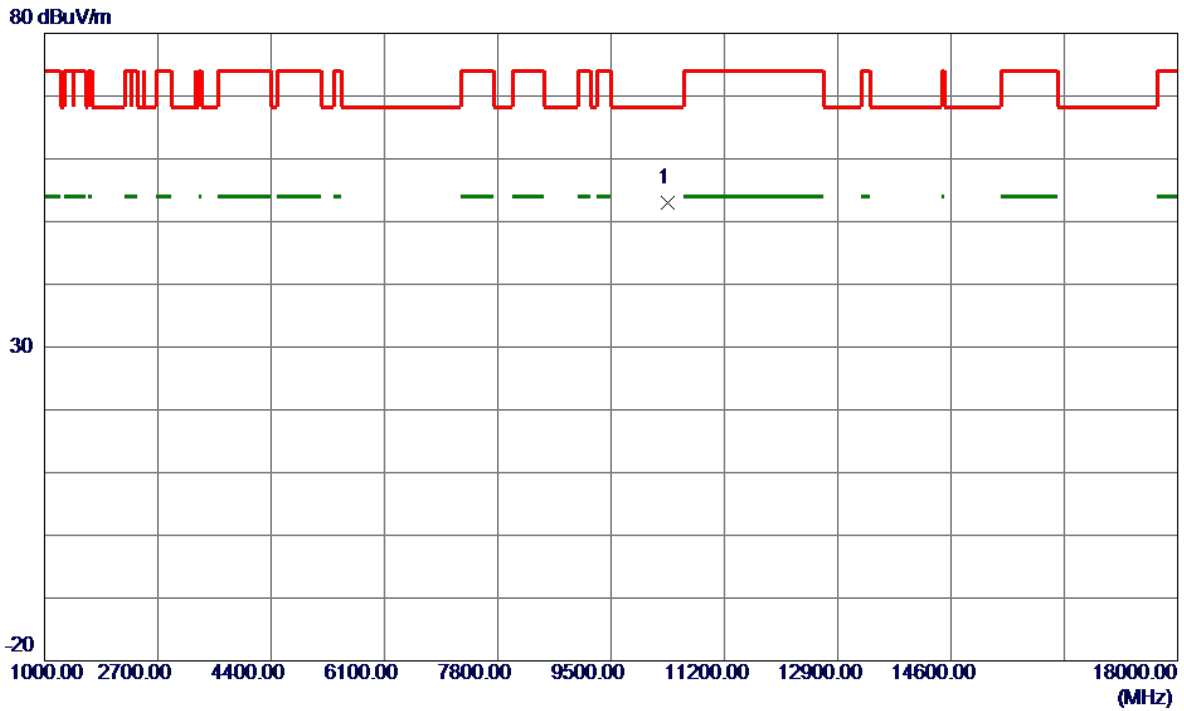

No.	Freq. MHz	Reading Level dBuV/m	Correct Factor dB	Measure ment dBuV/m	Limit dBuV/m	Margin dB	Detector	Comment
1 *	10358.5500	45.41	7.52	52.93	68.20	-15.27	Peak	

REMARKS:

- (1) Measurement Value = Reading Level + Correct Factor.
- (2) Margin Level = Measurement Value - Limit Value.

Test Mode	UNII-1_TX AX(HE20) Mode 5200 MHz	Polarization	Vertical
-----------	----------------------------------	--------------	----------

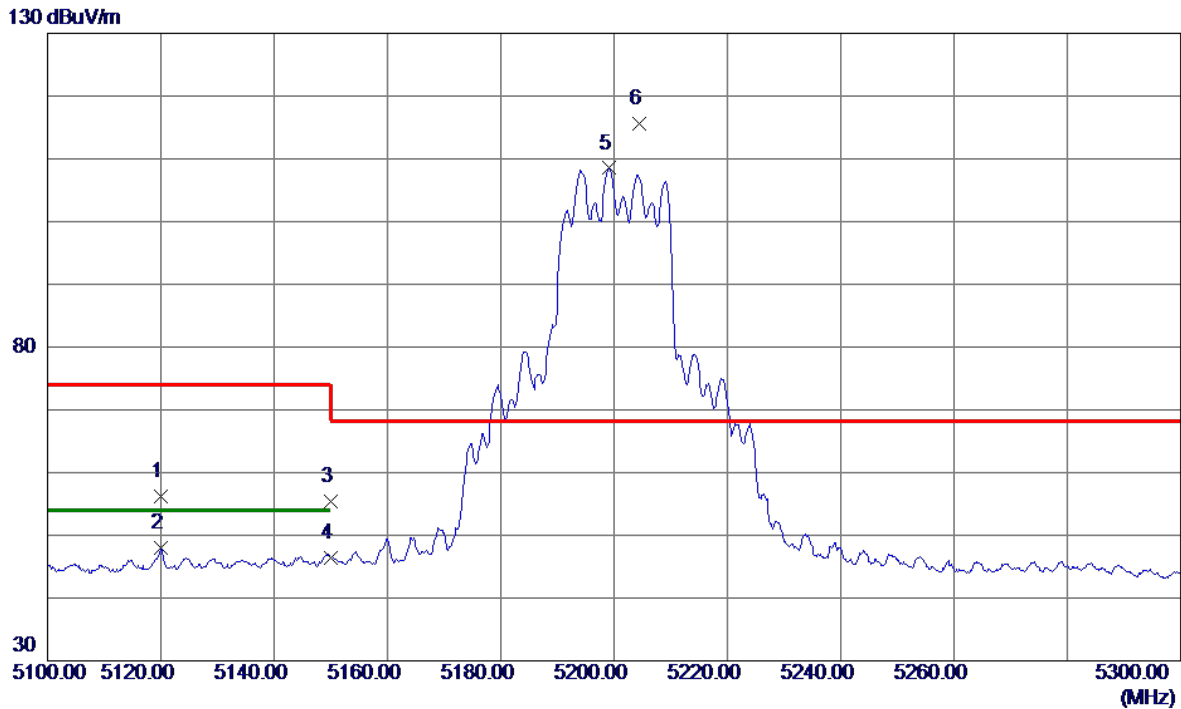

No.	Freq. MHz	Reading Level dBuV/m	Correct Factor dB	Measure ment dBuV/m	Limit dBuV/m	Margin dB	Detector	Comment
1	5120.0000	44.70	11.47	56.17	74.00	-17.83	Peak	
2	5120.0000	36.55	11.47	48.02	54.00	-5.98	AVG	
3	5150.0000	43.90	11.54	55.44	74.00	-18.56	Peak	
4	5150.0000	34.95	11.54	46.49	54.00	-7.51	AVG	
5	5199.2000	96.86	11.64	108.50	999.00	-890.50	AVG	No Limit
6 *	5204.4000	104.00	11.65	115.65	68.20	47.45	Peak	No Limit

REMARKS:

- (1) Measurement Value = Reading Level + Correct Factor.
- (2) Margin Level = Measurement Value - Limit Value.

Test Mode	UNII-1_TX AX(HE20) Mode 5200 MHz	Polarization	Horizontal
-----------	----------------------------------	--------------	------------

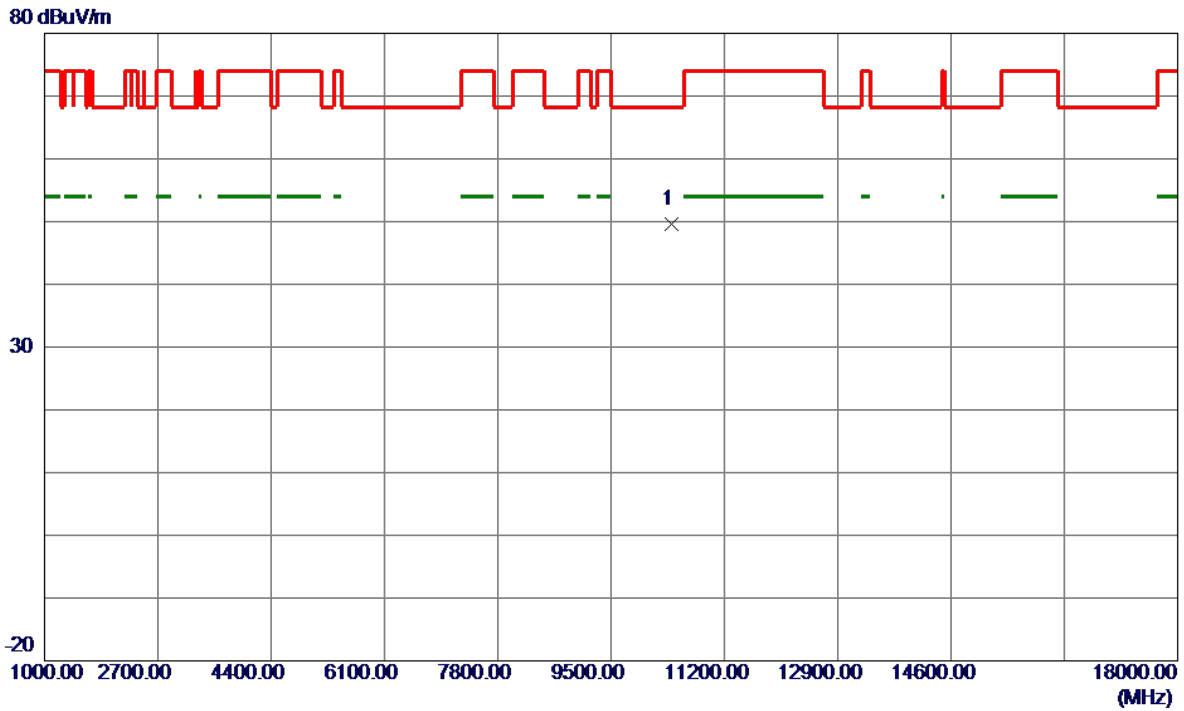

No.	Freq. MHz	Reading Level dBuV/m	Correct Factor dB	Measure ment dBuV/m	Limit dBuV/m	Margin dB	Detector	Comment
1 *	10398.4000	42.07	7.56	49.63	68.20	-18.57	Peak	

REMARKS:

- (1) Measurement Value = Reading Level + Correct Factor.
- (2) Margin Level = Measurement Value - Limit Value.

Test Mode	UNII-1_TX AX(HE20) Mode 5240 MHz	Polarization	Horizontal
-----------	----------------------------------	--------------	------------

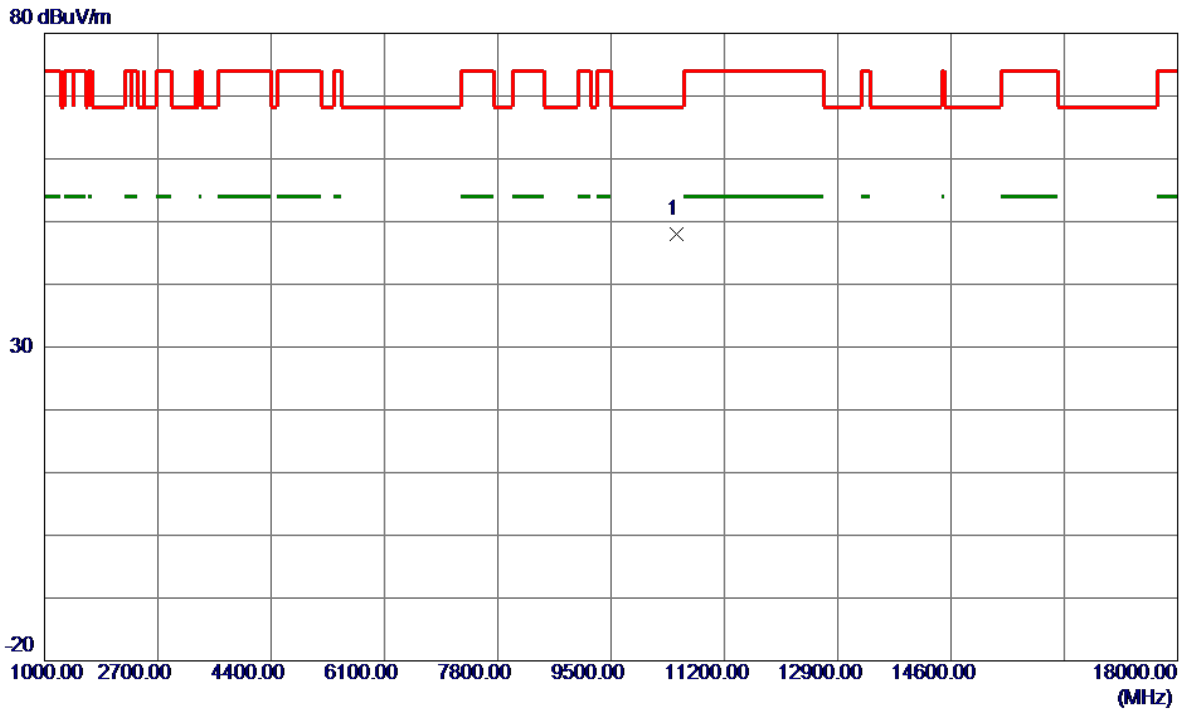

No.	Freq. MHz	Reading Level dBuV/m	Correct Factor dB	Measure ment dBuV/m	Limit dBuV/m	Margin dB	Detector	Comment
1 *	10477.9750	40.32	7.64	47.96	68.20	-20.24	Peak	

REMARKS:

- (1) Measurement Value = Reading Level + Correct Factor.
- (2) Margin Level = Measurement Value - Limit Value.

Test Mode	UNII-1_TX AX(HE40) Mode 5190 MHz	Polarization	Vertical
-----------	----------------------------------	--------------	----------

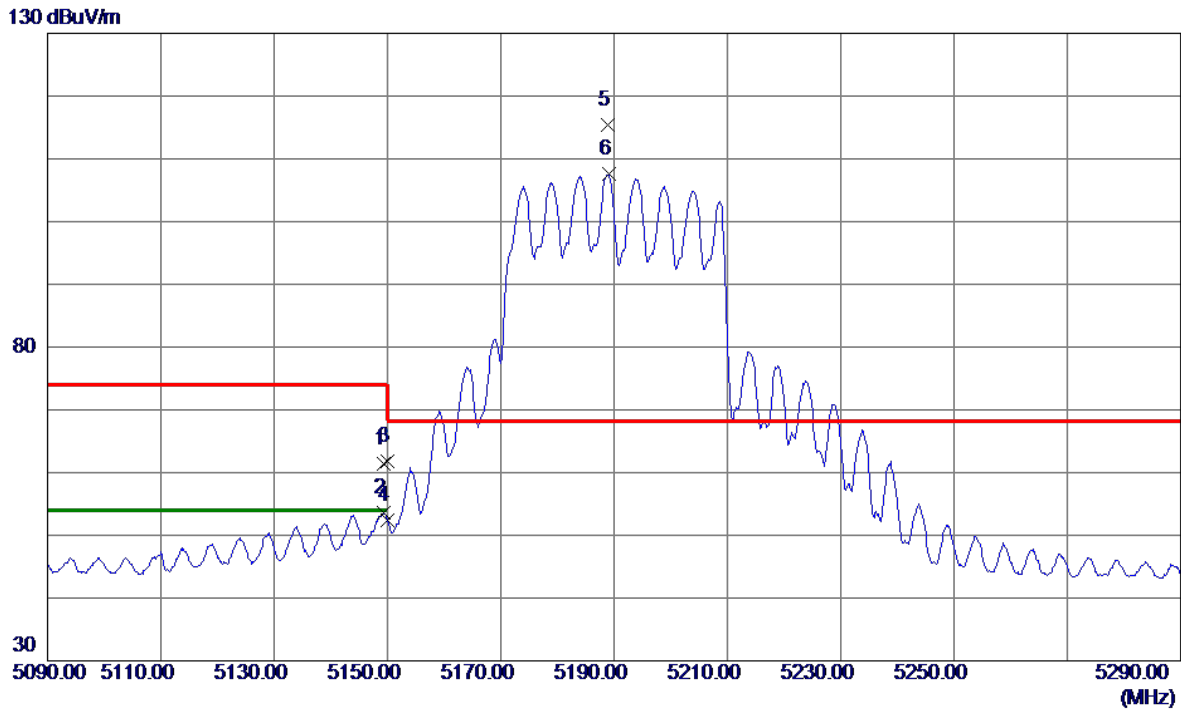

No.	Freq. MHz	Reading Level dBuV/m	Correct Factor dB	Measure ment dBuV/m	Limit dBuV/m	Margin dB	Detector	Comment
1	5149.4000	49.80	11.54	61.34	74.00	-12.66	Peak	
2	5149.4000	42.01	11.54	53.55	54.00	-0.45	AVG	
3	5150.0000	50.30	11.54	61.84	74.00	-12.16	Peak	
4	5150.0000	40.89	11.54	52.43	54.00	-1.57	AVG	
5 *	5188.8000	103.87	11.62	115.49	68.20	47.29	Peak	No Limit
6	5189.1000	95.90	11.62	107.52	999.00	-891.48	AVG	No Limit

REMARKS:

- (1) Measurement Value = Reading Level + Correct Factor.
- (2) Margin Level = Measurement Value - Limit Value.

Test Mode	UNII-1_TX AX(HE40) Mode 5190 MHz	Polarization	Horizontal
-----------	----------------------------------	--------------	------------

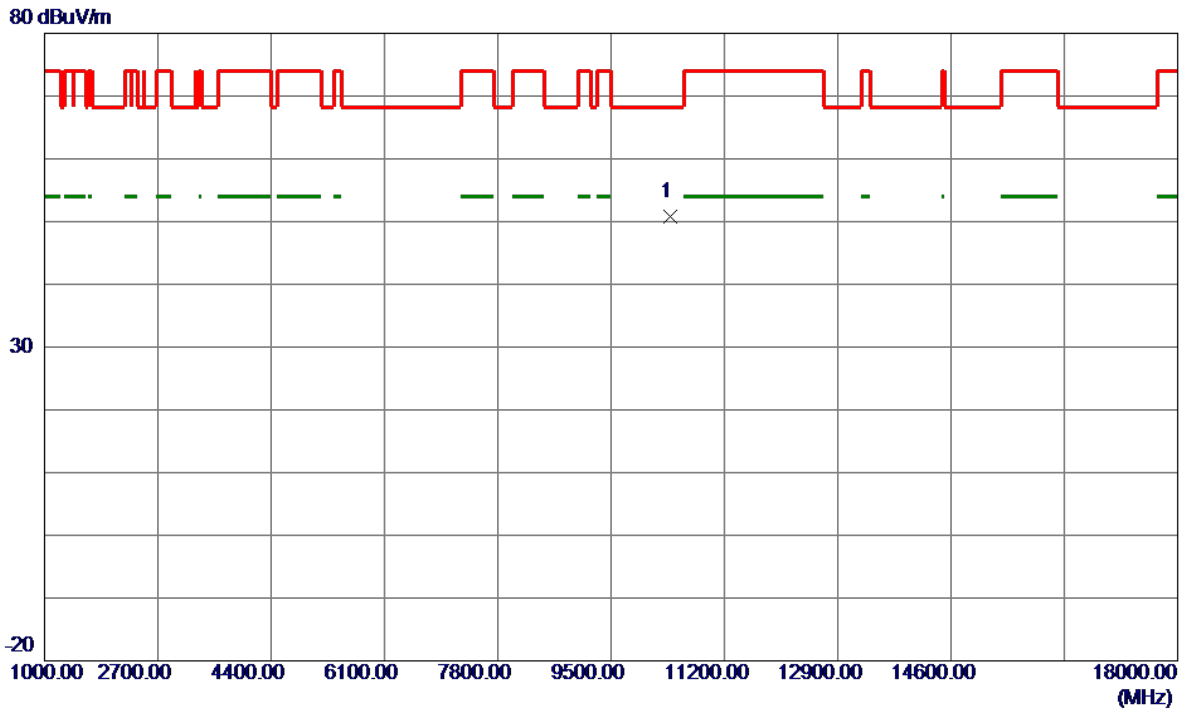

No.	Freq. MHz	Reading Level dBuV/m	Correct Factor dB	Measure ment dBuV/m	Limit dBuV/m	Margin dB	Detector	Comment
1 *	10383.5500	43.26	7.55	50.81	68.20	-17.39	Peak	

REMARKS:

- (1) Measurement Value = Reading Level + Correct Factor.
- (2) Margin Level = Measurement Value - Limit Value.

Test Mode	UNII-1_TX AX(HE40) Mode 5230 MHz	Polarization	Vertical
-----------	----------------------------------	--------------	----------

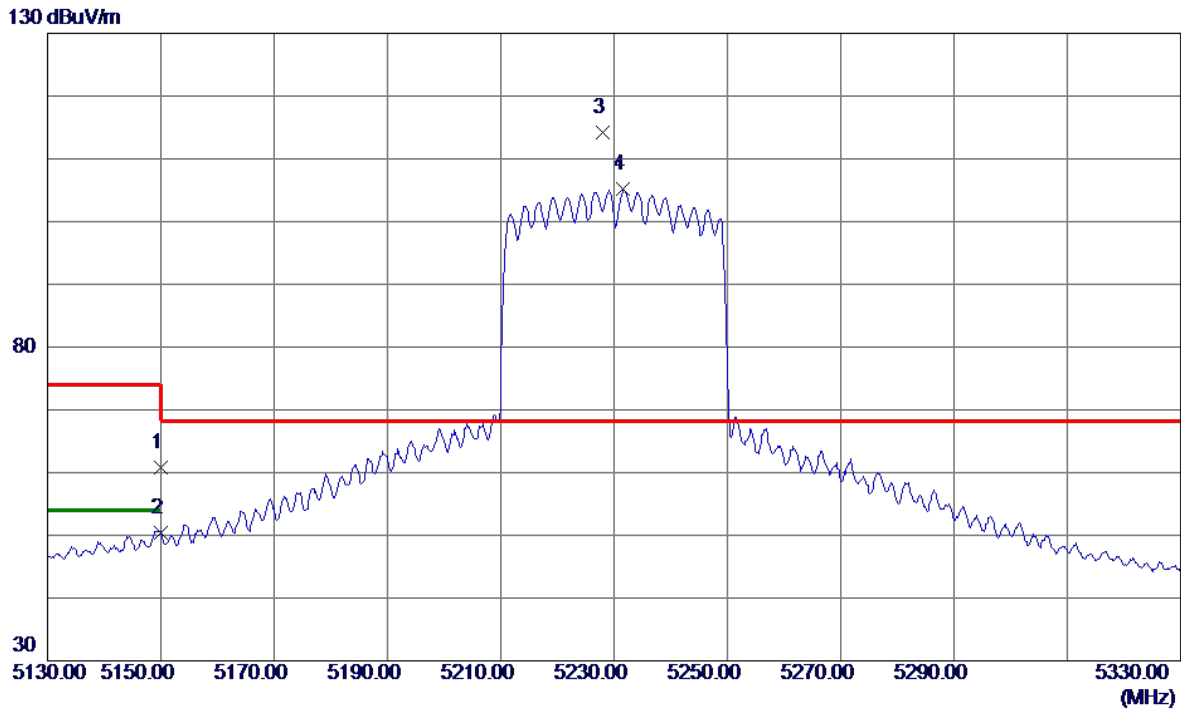

No.	Freq. MHz	Reading Level dBuV/m	Correct Factor dB	Measure ment dBuV/m	Limit dBuV/m	Margin dB	Detector	Comment
1	5150.0000	49.28	11.54	60.82	74.00	-13.18	Peak	
2	5150.0000	38.81	11.54	50.35	54.00	-3.65	AVG	
3 *	5227.9000	102.53	11.70	114.23	68.20	46.03	Peak	No Limit
4	5231.6000	93.40	11.71	105.11	999.00	-893.89	AVG	No Limit

REMARKS:

- (1) Measurement Value = Reading Level + Correct Factor.
- (2) Margin Level = Measurement Value - Limit Value.

Test Mode	UNII-1_TX AX(HE40) Mode 5230 MHz	Polarization	Horizontal
-----------	----------------------------------	--------------	------------

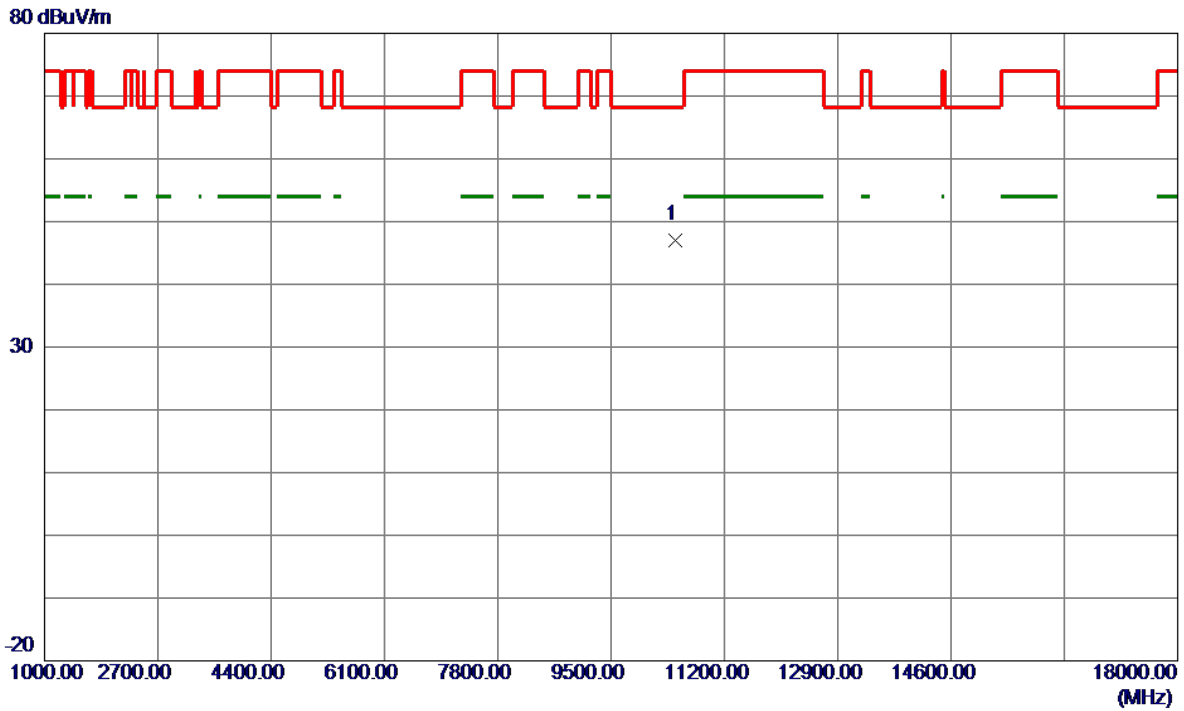

No.	Freq. MHz	Reading Level dBuV/m	Correct Factor dB	Measure ment dBuV/m	Limit dBuV/m	Margin dB	Detector	Comment
1 *	10461.5500	39.48	7.62	47.10	68.20	-21.10	Peak	

REMARKS:

- (1) Measurement Value = Reading Level + Correct Factor.
- (2) Margin Level = Measurement Value - Limit Value.

Test Mode	UNII-1_TX AX(HE80) Mode 5210 MHz	Polarization	Vertical
-----------	----------------------------------	--------------	----------

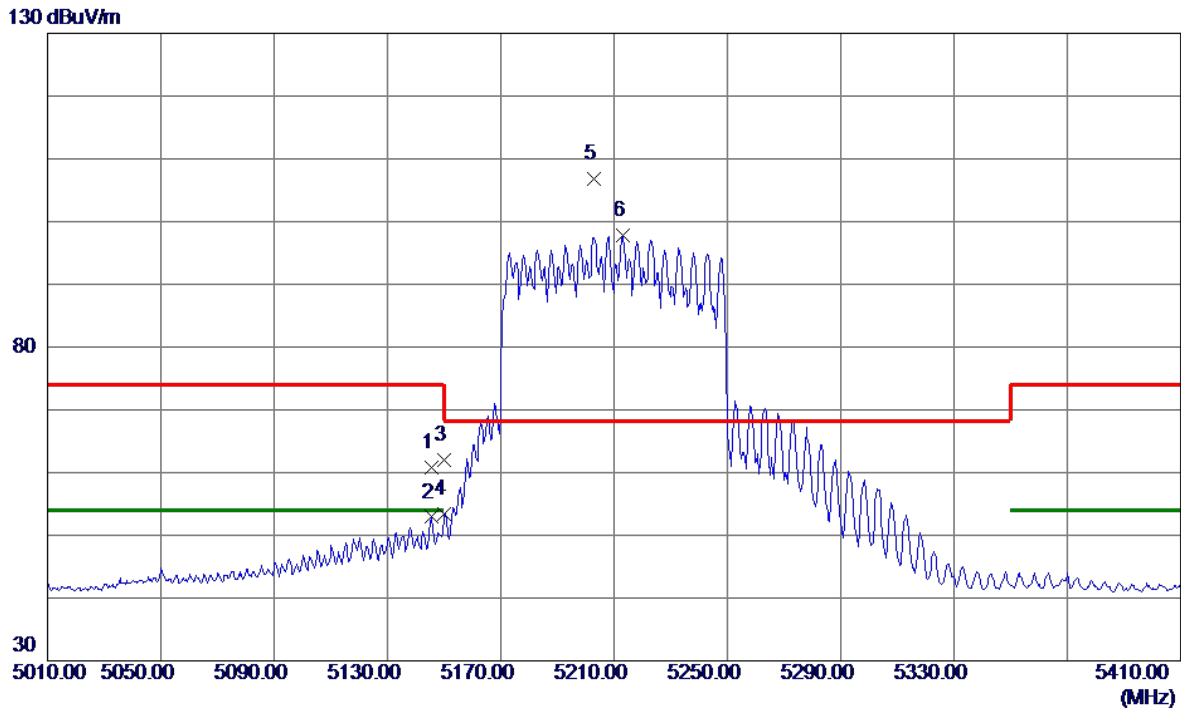

No.	Freq. MHz	Reading Level dBuV/m	Correct Factor dB	Measure ment dBuV/m	Limit dBuV/m	Margin dB	Detector	Comment
1	5145.4000	49.36	11.53	60.89	74.00	-13.11	Peak	
2	5145.4000	41.37	11.53	52.90	54.00	-1.10	AVG	
3	5150.0000	50.43	11.54	61.97	74.00	-12.03	Peak	
4	5150.0000	41.88	11.54	53.42	54.00	-0.58	AVG	
5 *	5203.0000	95.21	11.65	106.86	68.20	38.66	Peak	No Limit
6	5213.0000	86.05	11.67	97.72	999.00	-901.28	AVG	No Limit

REMARKS:

- (1) Measurement Value = Reading Level + Correct Factor.
- (2) Margin Level = Measurement Value - Limit Value.

Test Mode	UNII-1_TX AX(HE80) Mode 5210 MHz	Polarization	Horizontal
-----------	----------------------------------	--------------	------------

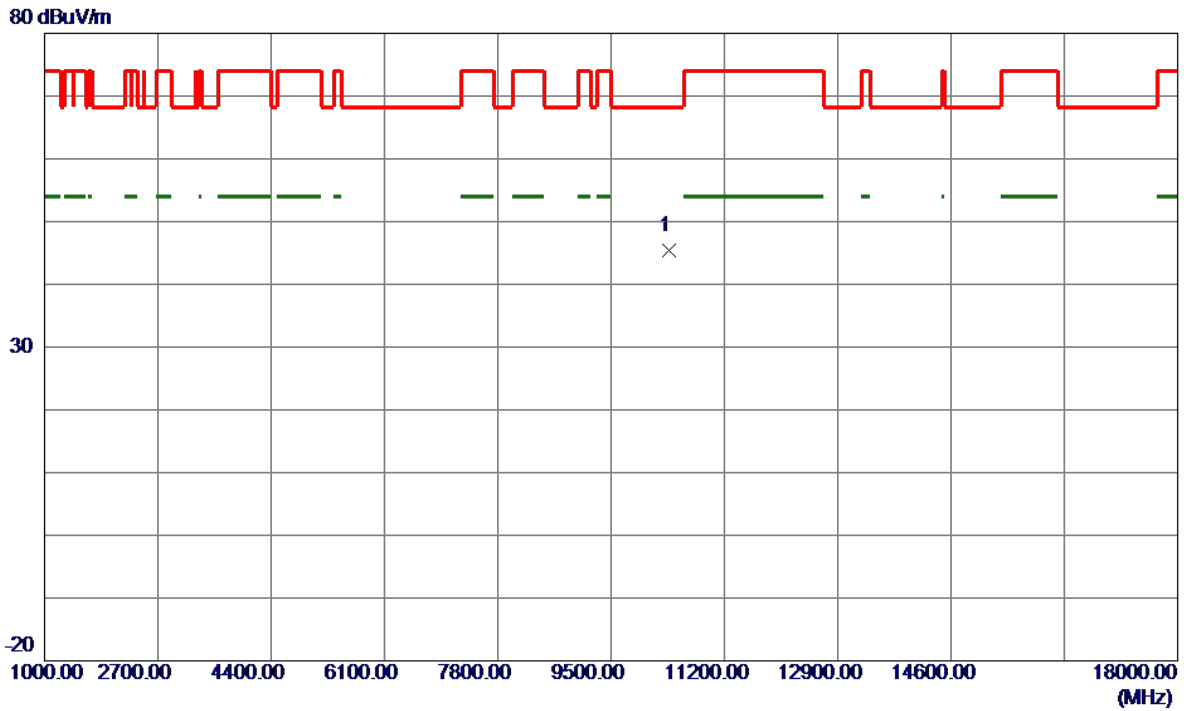

No.	Freq. MHz	Reading Level dBuV/m	Correct Factor dB	Measure ment dBuV/m	Limit dBuV/m	Margin dB	Detector	Comment
1 *	10371.4500	37.80	7.53	45.33	68.20	-22.87	Peak	

REMARKS:

- (1) Measurement Value = Reading Level + Correct Factor.
- (2) Margin Level = Measurement Value - Limit Value.

Test Mode	UNII-2A_TX A Mode 5260 MHz	Polarization	Horizontal
-----------	----------------------------	--------------	------------

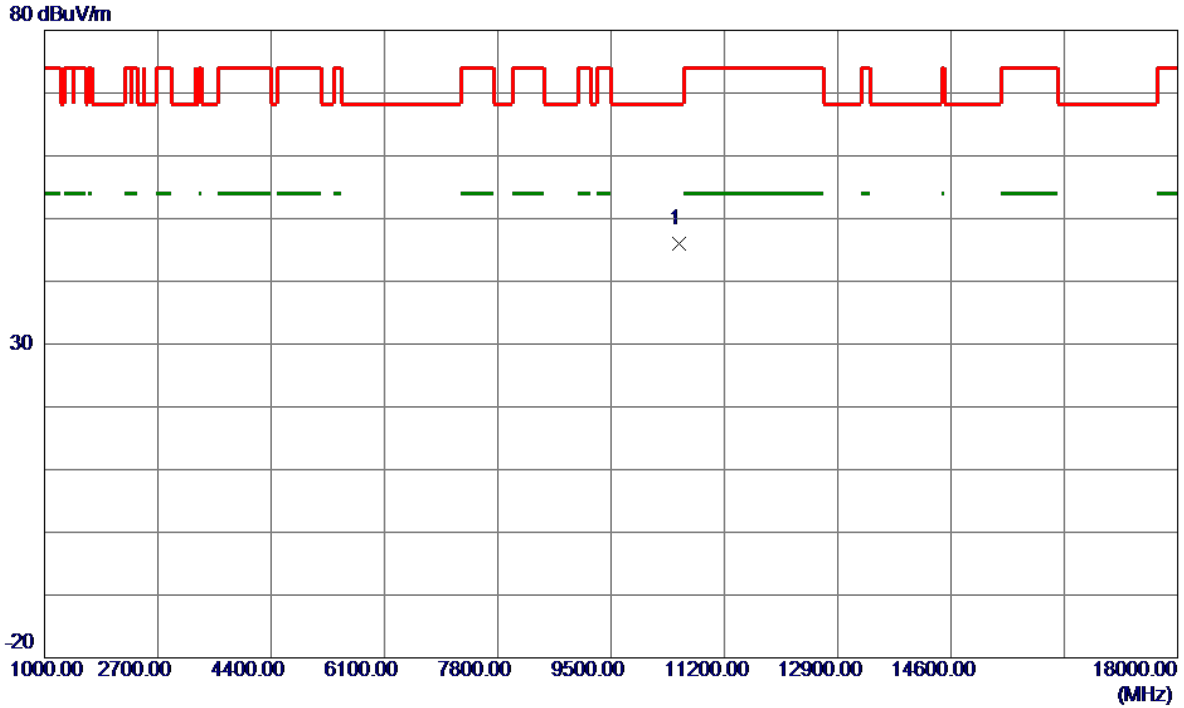

No.	Freq. MHz	Reading Level dBuV/m	Correct Factor dB	Measure ment dBuV/m	Limit dBuV/m	Margin dB	Detector	Comment
1 *	10511.5250	38.31	7.67	45.98	68.20	-22.22	Peak	

REMARKS:

- (1) Measurement Value = Reading Level + Correct Factor.
- (2) Margin Level = Measurement Value - Limit Value.

Test Mode	UNII-2A_TX A Mode 5300 MHz	Polarization	Vertical
-----------	----------------------------	--------------	----------

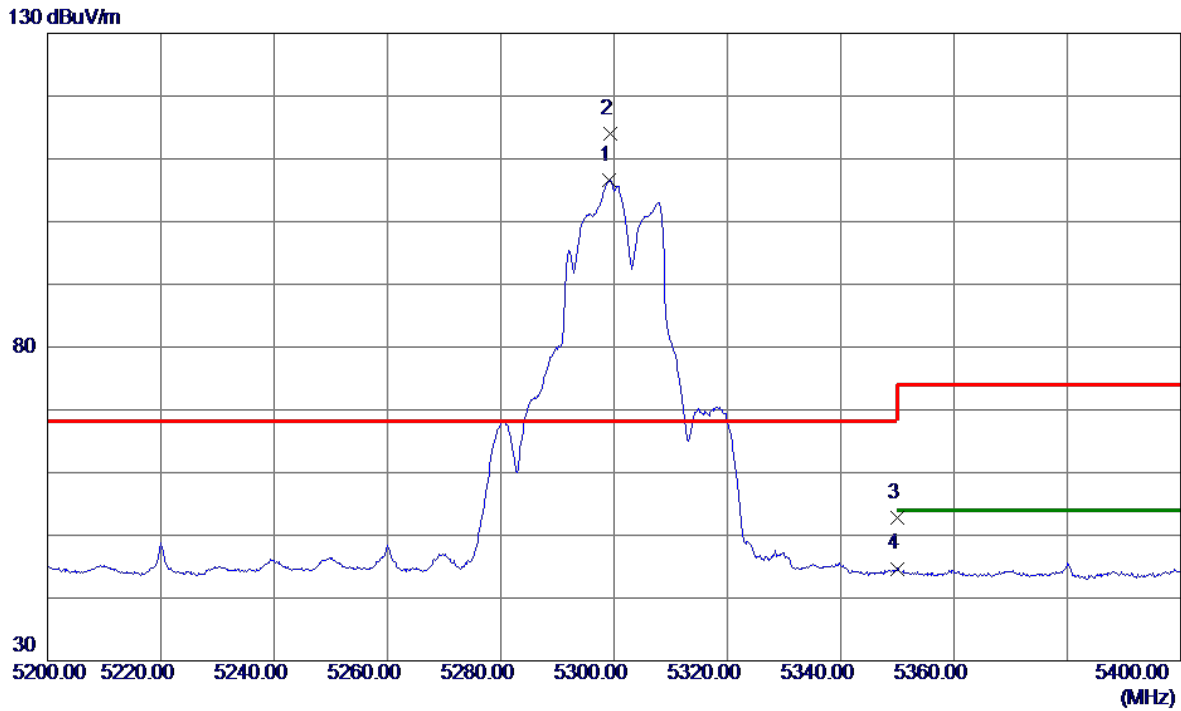

No.	Freq. MHz	Reading Level dBuV/m	Correct Factor dB	Measure ment dBuV/m	Limit dBuV/m	Margin dB	Detector	Comment
1	5299.2000	94.75	11.85	106.60	999.00	-892.40	AVG	No Limit
2 *	5299.4000	102.21	11.85	114.06	68.20	45.86	Peak	No Limit
3	5350.0000	40.92	11.96	52.88	74.00	-21.12	Peak	
4	5350.0000	32.74	11.96	44.70	54.00	-9.30	AVG	

REMARKS:

- (1) Measurement Value = Reading Level + Correct Factor.
- (2) Margin Level = Measurement Value - Limit Value.

Test Mode	UNII-2A_TX A Mode 5300 MHz	Polarization	Horizontal
-----------	----------------------------	--------------	------------

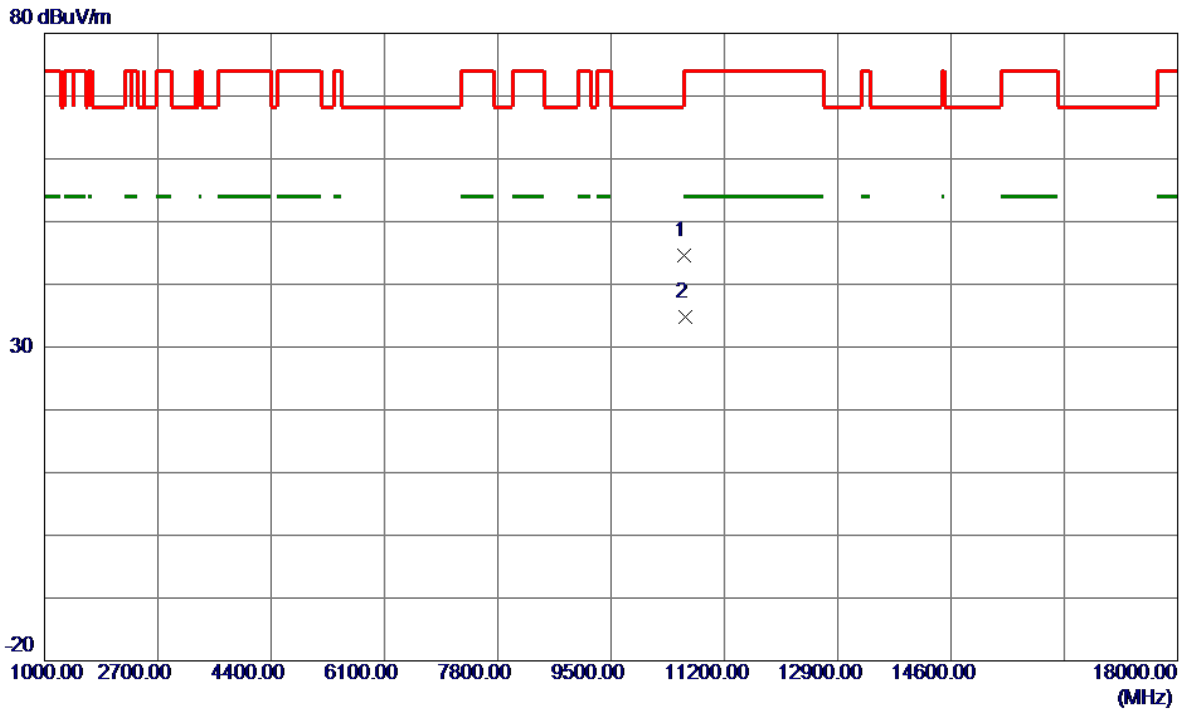

No.	Freq. MHz	Reading Level dBuV/m	Correct Factor dB	Measure ment dBuV/m	Limit dBuV/m	Margin dB	Detector	Comment
1	10604.3750	36.92	7.74	44.66	74.00	-29.34	Peak	
2 *	10607.5250	27.03	7.74	34.77	54.00	-19.23	AVG	

REMARKS:

- (1) Measurement Value = Reading Level + Correct Factor.
- (2) Margin Level = Measurement Value - Limit Value.

Test Mode	UNII-2A_TX A Mode 5320 MHz	Polarization	Vertical
-----------	----------------------------	--------------	----------

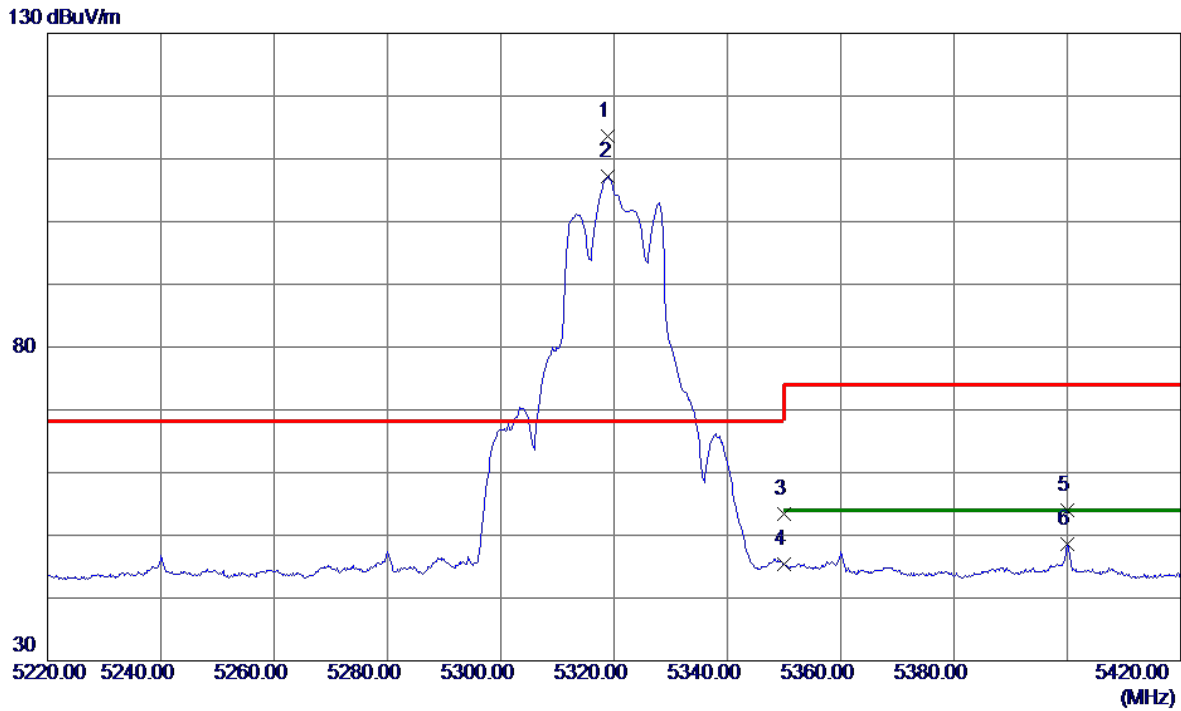

No.	Freq. MHz	Reading Level dBuV/m	Correct Factor dB	Measure ment dBuV/m	Limit dBuV/m	Margin dB	Detector	Comment
1 *	5318.8000	101.71	11.89	113.60	68.20	45.40	Peak	No Limit
2	5319.0000	95.28	11.89	107.17	999.00	-891.83	AVG	No Limit
3	5350.0000	41.47	11.96	53.43	74.00	-20.57	Peak	
4	5350.0000	33.42	11.96	45.38	54.00	-8.62	AVG	
5	5399.9000	41.99	12.06	54.05	74.00	-19.95	Peak	
6	5399.9000	36.50	12.06	48.56	54.00	-5.44	AVG	

REMARKS:

- (1) Measurement Value = Reading Level + Correct Factor.
- (2) Margin Level = Measurement Value - Limit Value.

Test Mode	UNII-2A_TX A Mode 5320 MHz	Polarization	Horizontal
-----------	----------------------------	--------------	------------

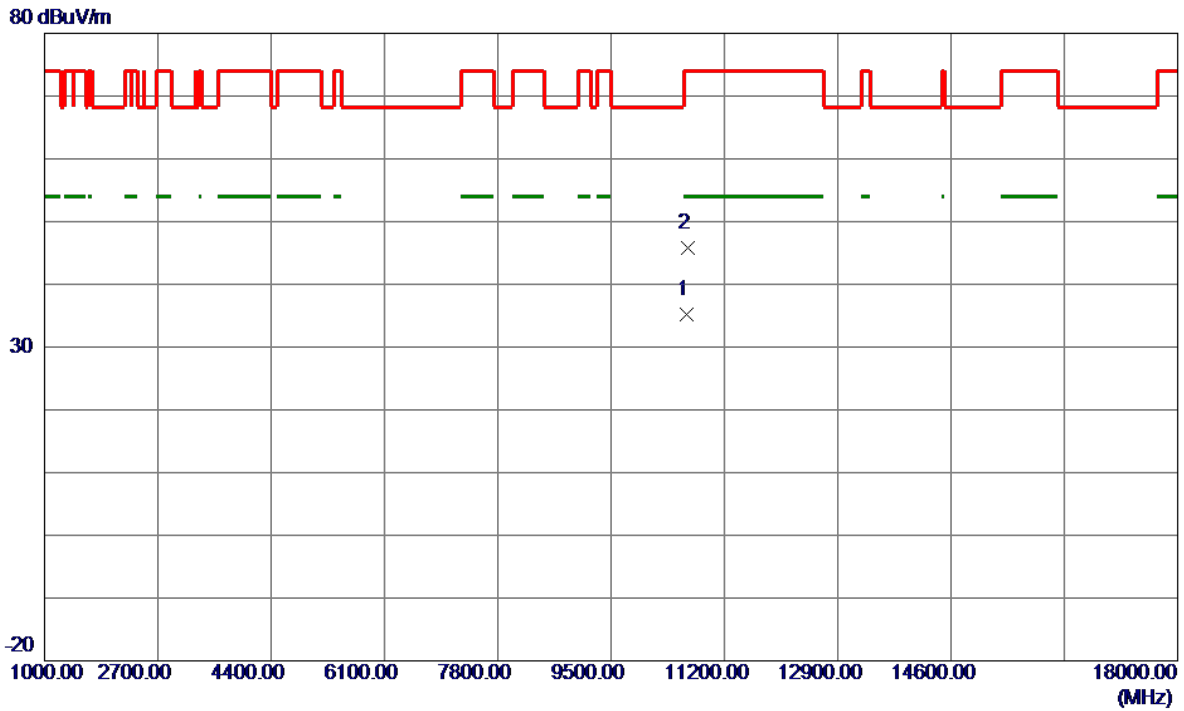

No.	Freq. MHz	Reading Level dBuV/m	Correct Factor dB	Measure ment dBuV/m	Limit dBuV/m	Margin dB	Detector	Comment
1 *	10640.2000	27.43	7.76	35.19	54.00	-18.81	AVG	
2	10649.6750	38.01	7.77	45.78	74.00	-28.22	Peak	

REMARKS:

- (1) Measurement Value = Reading Level + Correct Factor.
- (2) Margin Level = Measurement Value - Limit Value.

Test Mode	UNII-2A_TX AC(VHT20) Mode 5260 MHz	Polarization	Horizontal
-----------	------------------------------------	--------------	------------

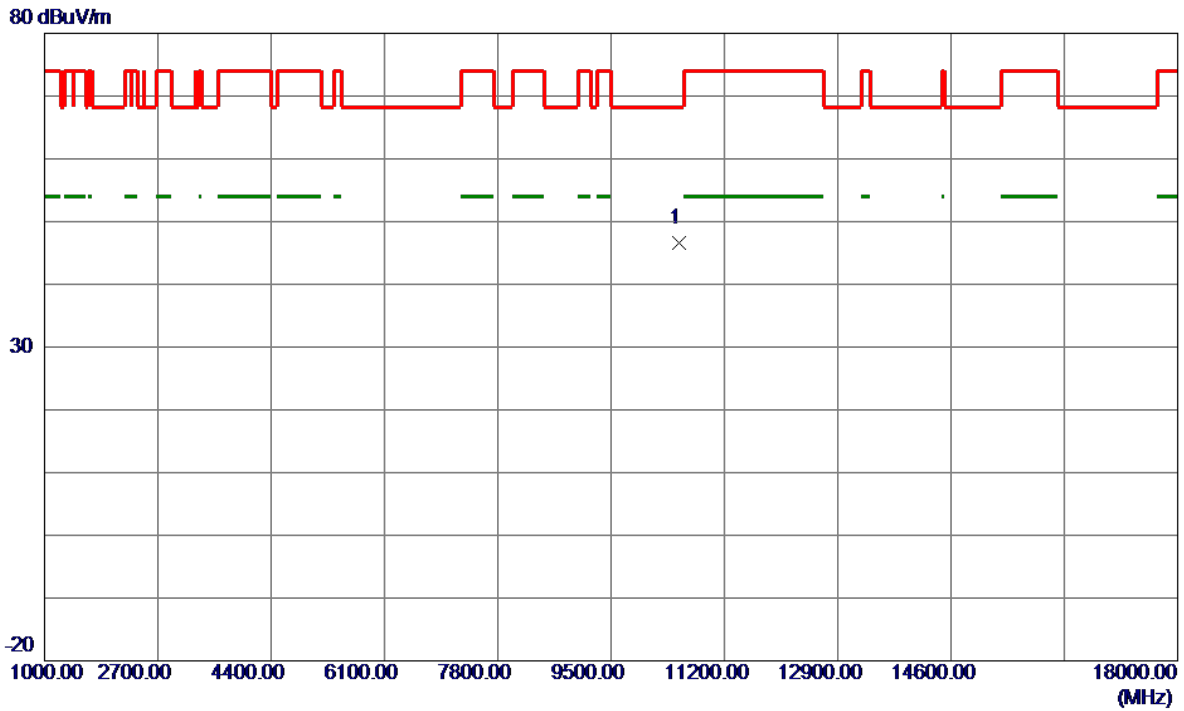

No.	Freq. MHz	Reading Level dBuV/m	Correct Factor dB	Measure ment dBuV/m	Limit dBuV/m	Margin dB	Detector	Comment
1 *	10519.2000	38.94	7.67	46.61	68.20	-21.59	Peak	

REMARKS:

- (1) Measurement Value = Reading Level + Correct Factor.
- (2) Margin Level = Measurement Value - Limit Value.

Test Mode	UNII-2A_TX AC(VHT20) Mode 5300 MHz	Polarization	Vertical
-----------	------------------------------------	--------------	----------

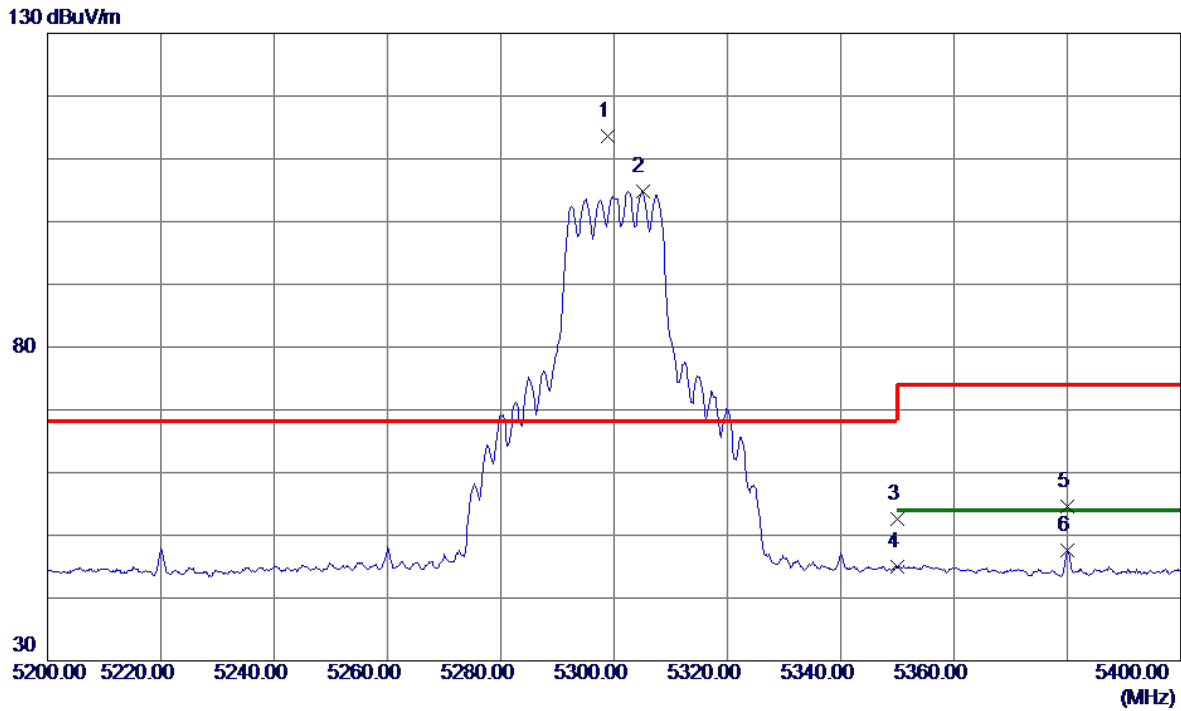

No.	Freq. MHz	Reading Level dBuV/m	Correct Factor dB	Measure ment dBuV/m	Limit dBuV/m	Margin dB	Detector	Comment
1 *	5298.9000	101.83	11.85	113.68	68.20	45.48	Peak	No Limit
2	5305.0000	92.99	11.86	104.85	999.00	-894.15	AVG	No Limit
3	5350.0000	40.63	11.96	52.59	74.00	-21.41	Peak	
4	5350.0000	33.02	11.96	44.98	54.00	-9.02	AVG	
5	5380.0000	42.56	12.02	54.58	74.00	-19.42	Peak	
6	5380.0000	35.57	12.02	47.59	54.00	-6.41	AVG	

REMARKS:

- (1) Measurement Value = Reading Level + Correct Factor.
- (2) Margin Level = Measurement Value - Limit Value.

Test Mode	UNII-2A_TX AC(VHT20) Mode 5300 MHz	Polarization	Horizontal
-----------	------------------------------------	--------------	------------

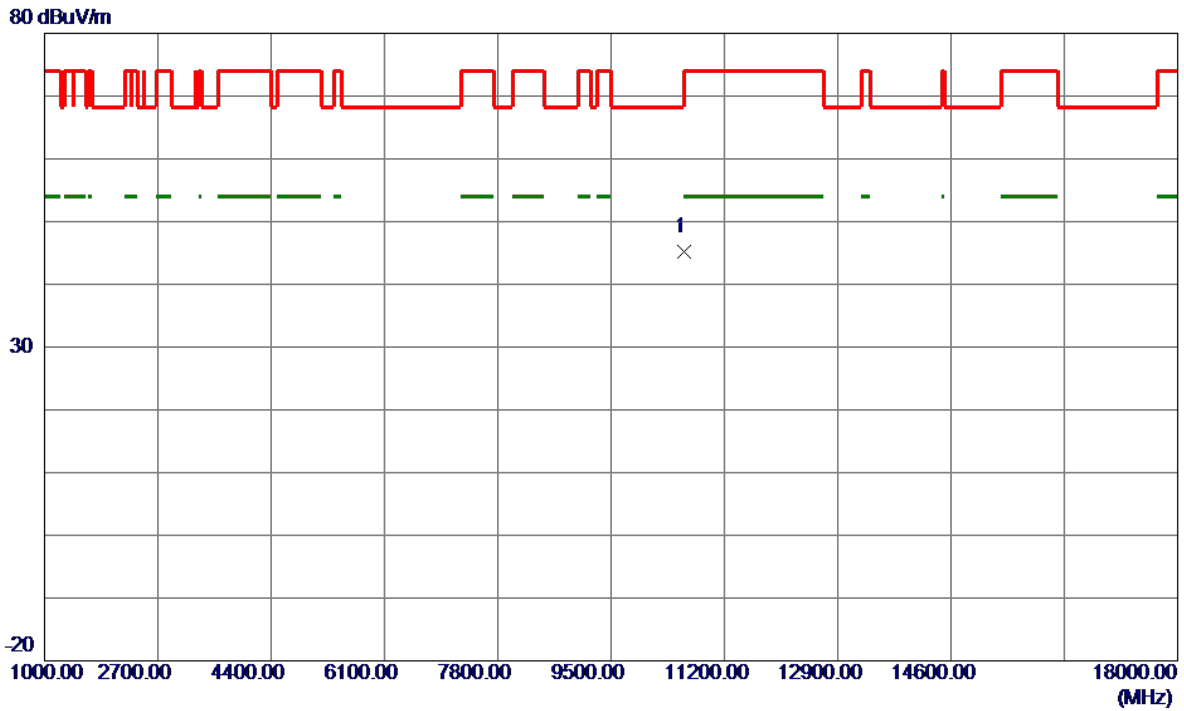

No.	Freq. MHz	Reading Level dBuV/m	Correct Factor dB	Measure ment dBuV/m	Limit dBuV/m	Margin dB	Detector	Comment
1 *	10590.1250	37.43	7.73	45.16	68.20	-23.04	Peak	

REMARKS:

- (1) Measurement Value = Reading Level + Correct Factor.
- (2) Margin Level = Measurement Value - Limit Value.

Test Mode	UNII-2A_TX AC(VHT20) Mode 5320 MHz	Polarization	Vertical
-----------	------------------------------------	--------------	----------

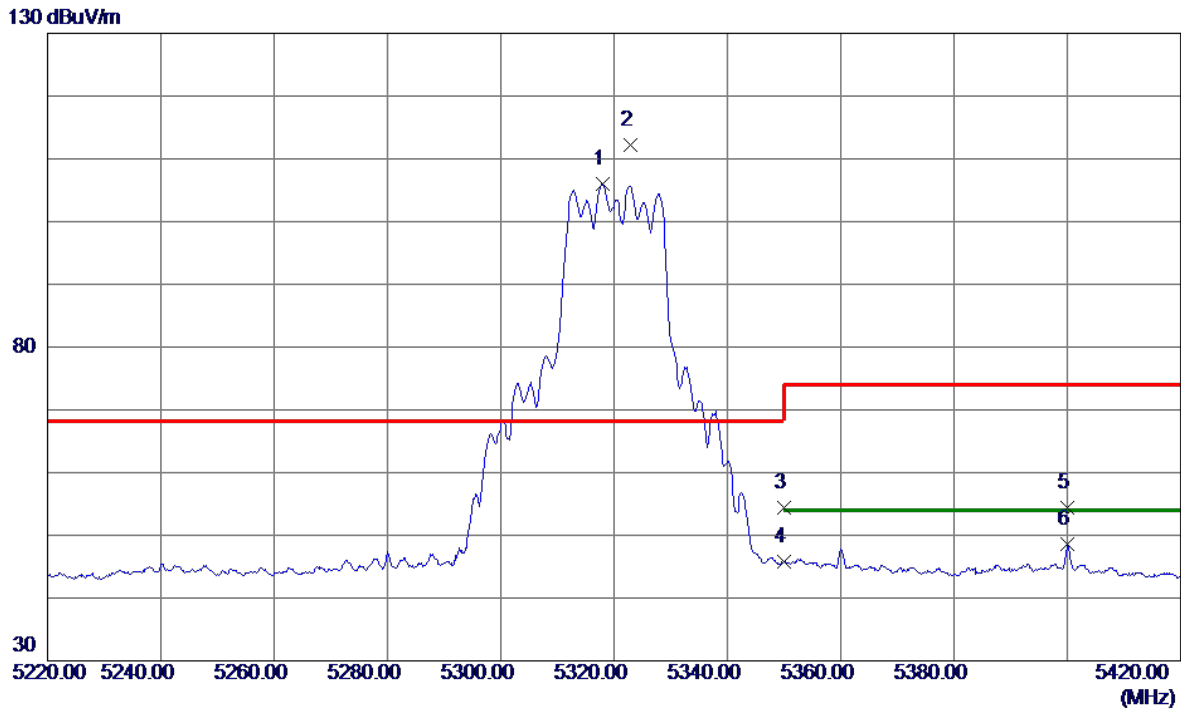

No.	Freq. MHz	Reading Level dBuV/m	Correct Factor dB	Measure ment dBuV/m	Limit dBuV/m	Margin dB	Detector	Comment
1	5317.9000	94.12	11.89	106.01	999.00	-892.99	AVG	No Limit
2 *	5322.9000	100.31	11.90	112.21	68.20	44.01	Peak	No Limit
3	5350.0000	42.48	11.96	54.44	74.00	-19.56	Peak	
4	5350.0000	33.77	11.96	45.73	54.00	-8.27	AVG	
5	5400.1000	42.32	12.06	54.38	74.00	-19.62	Peak	
6	5400.1000	36.49	12.06	48.55	54.00	-5.45	AVG	

REMARKS:

- (1) Measurement Value = Reading Level + Correct Factor.
- (2) Margin Level = Measurement Value - Limit Value.

Test Mode	UNII-2A_TX AC(VHT20) Mode 5320 MHz	Polarization	Horizontal
-----------	------------------------------------	--------------	------------

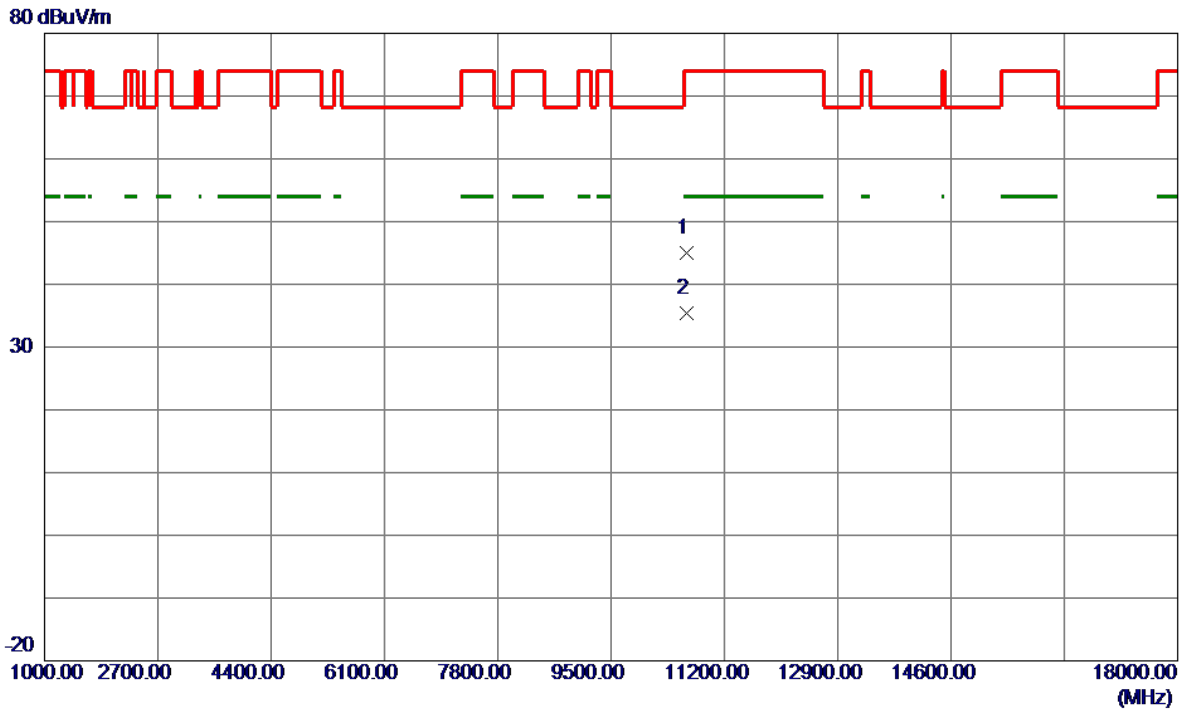

No.	Freq. MHz	Reading Level dBuV/m	Correct Factor dB	Measure ment dBuV/m	Limit dBuV/m	Margin dB	Detector	Comment
1	10629.1250	37.29	7.76	45.05	74.00	-28.95	Peak	
2 *	10640.0500	27.58	7.76	35.34	54.00	-18.66	AVG	

REMARKS:

- (1) Measurement Value = Reading Level + Correct Factor.
- (2) Margin Level = Measurement Value - Limit Value.

Test Mode	UNII-2A_TX AC(VHT40) Mode 5270 MHz	Polarization	Vertical
-----------	------------------------------------	--------------	----------

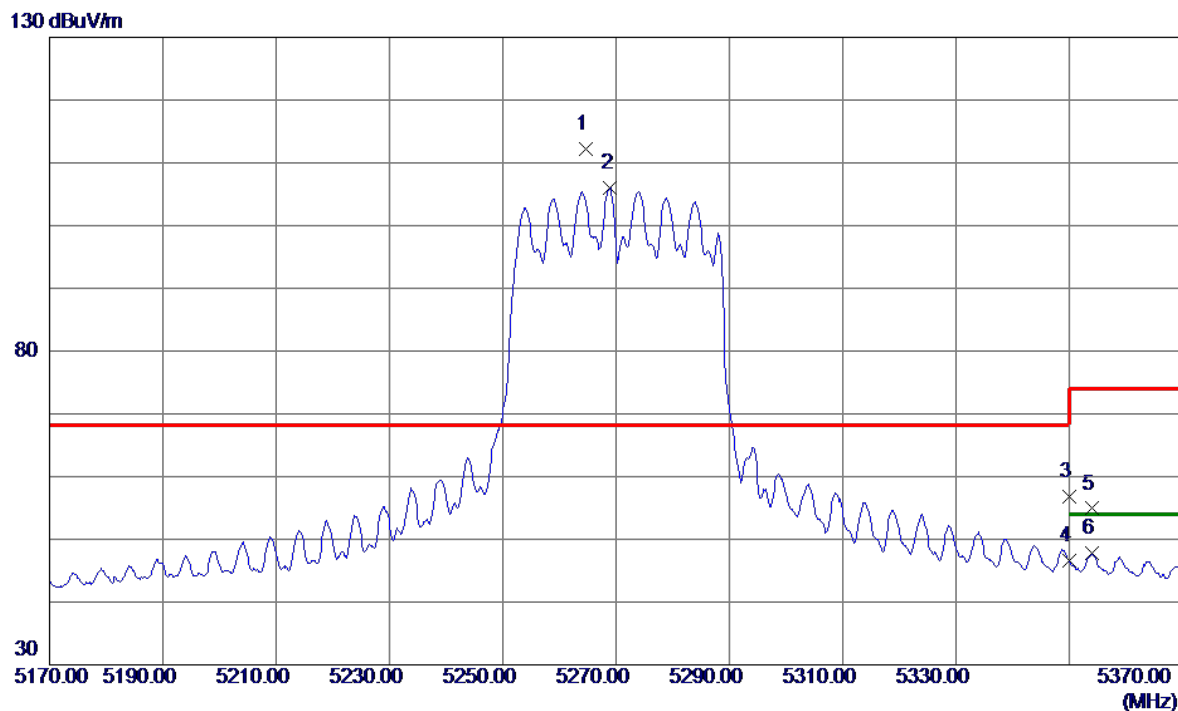

No.	Freq. MHz	Reading Level dBuV/m	Correct Factor dB	Measure ment dBuV/m	Limit dBuV/m	Margin dB	Detector	Comment
1 *	5264.6000	100.44	11.78	112.22	68.20	44.02	Peak	No Limit
2	5269.0000	94.14	11.79	105.93	999.00	-893.07	AVG	No Limit
3	5350.0000	44.91	11.96	56.87	74.00	-17.13	Peak	
4	5350.0000	34.64	11.96	46.60	54.00	-7.40	AVG	
5	5354.1000	42.93	11.97	54.90	74.00	-19.10	Peak	
6	5354.1000	35.82	11.97	47.79	54.00	-6.21	AVG	

REMARKS:

- (1) Measurement Value = Reading Level + Correct Factor.
- (2) Margin Level = Measurement Value - Limit Value.

Test Mode	UNII-2A_TX AC(VHT40) Mode 5270 MHz	Polarization	Horizontal
-----------	------------------------------------	--------------	------------

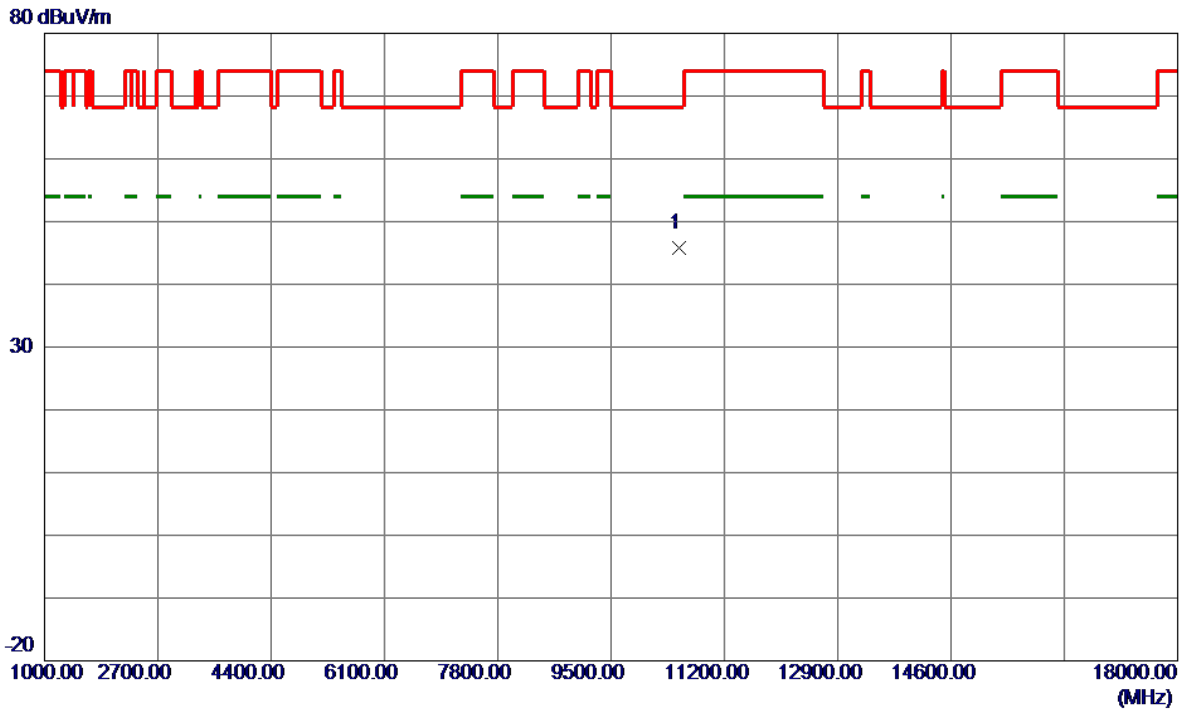

No.	Freq. MHz	Reading Level dBuV/m	Correct Factor dB	Measure ment dBuV/m	Limit dBuV/m	Margin dB	Detector	Comment
1 *	10521.1750	38.05	7.68	45.73	68.20	-22.47	Peak	

REMARKS:

- (1) Measurement Value = Reading Level + Correct Factor.
- (2) Margin Level = Measurement Value - Limit Value.

Test Mode	UNII-2A_TX AC(VHT40) Mode 5310 MHz	Polarization	Vertical
-----------	------------------------------------	--------------	----------

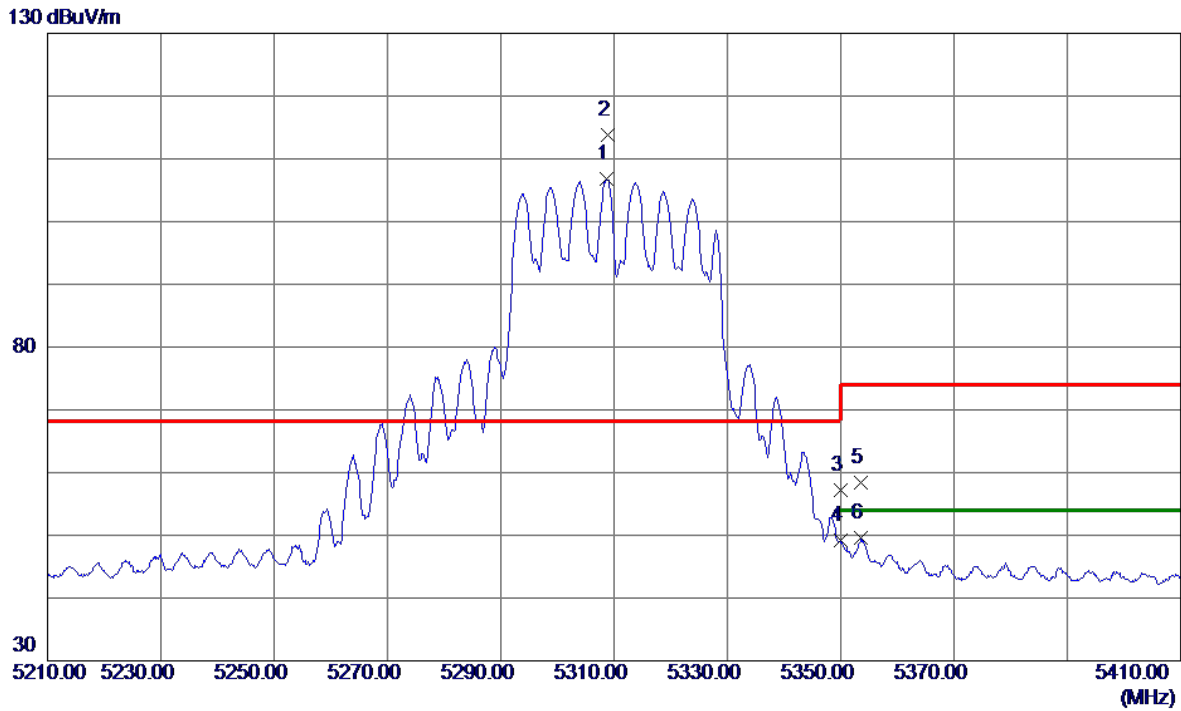

No.	Freq. MHz	Reading Level dBuV/m	Correct Factor dB	Measure ment dBuV/m	Limit dBuV/m	Margin dB	Detector	Comment
1	5308.6000	94.99	11.87	106.86	999.00	-892.14	AVG	No Limit
2 *	5308.8000	101.84	11.87	113.71	68.20	45.51	Peak	No Limit
3	5350.0000	45.16	11.96	57.12	74.00	-16.88	Peak	
4	5350.0000	37.24	11.96	49.20	54.00	-4.80	AVG	
5	5353.6000	46.42	11.97	58.39	74.00	-15.61	Peak	
6	5353.6000	37.61	11.97	49.58	54.00	-4.42	AVG	

REMARKS:

- (1) Measurement Value = Reading Level + Correct Factor.
- (2) Margin Level = Measurement Value - Limit Value.

Test Mode	UNII-2A_TX AC(VHT40) Mode 5310 MHz	Polarization	Horizontal
-----------	------------------------------------	--------------	------------

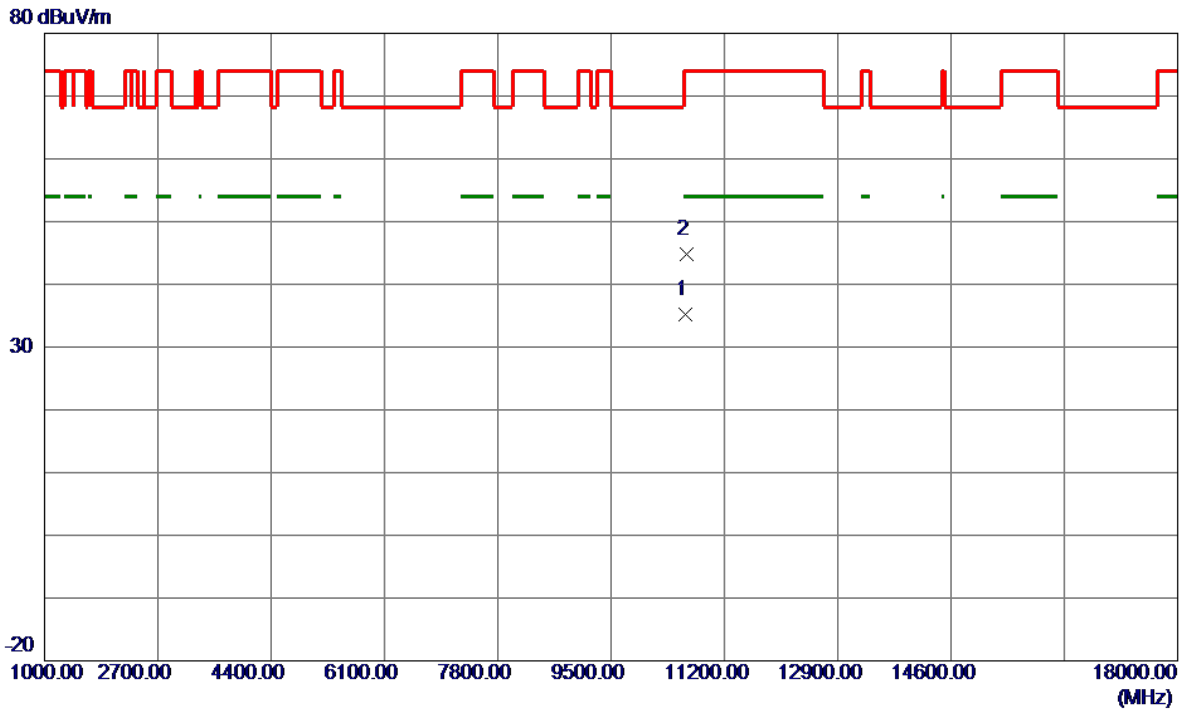

No.	Freq. MHz	Reading Level dBuV/m	Correct Factor dB	Measure ment dBuV/m	Limit dBuV/m	Margin dB	Detector	Comment
1 *	10613.8000	27.39	7.74	35.13	54.00	-18.87	AVG	
2	10625.7750	37.14	7.75	44.89	74.00	-29.11	Peak	

REMARKS:

- (1) Measurement Value = Reading Level + Correct Factor.
- (2) Margin Level = Measurement Value - Limit Value.

Test Mode	UNII-2A_TX AC(VHT80) Mode 5290 MHz	Polarization	Vertical
-----------	------------------------------------	--------------	----------

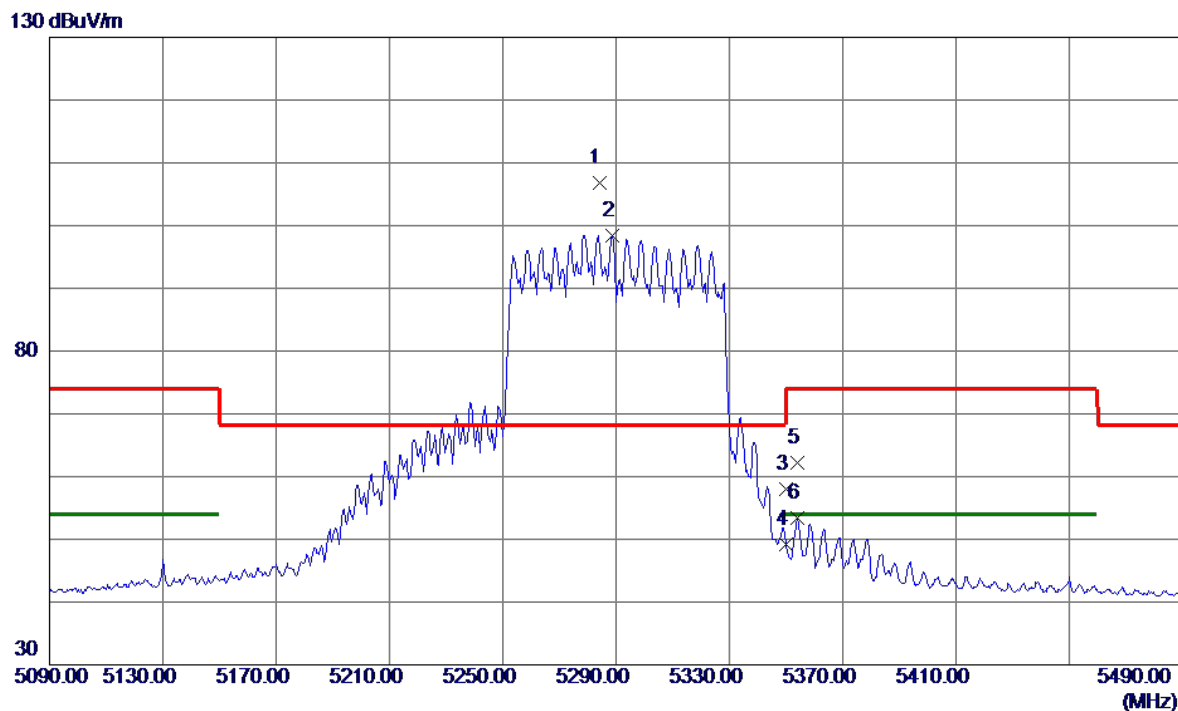

No.	Freq. MHz	Reading Level dBuV/m	Correct Factor dB	Measure ment dBuV/m	Limit dBuV/m	Margin dB	Detector	Comment
1 *	5284.0000	94.95	11.82	106.77	68.20	38.57	Peak	No Limit
2	5288.6000	86.62	11.83	98.45	999.00	-900.55	AVG	No Limit
3	5350.0000	46.08	11.96	58.04	74.00	-15.96	Peak	
4	5350.0000	37.29	11.96	49.25	54.00	-4.75	AVG	
5	5354.0000	50.17	11.97	62.14	74.00	-11.86	Peak	
6	5354.0000	41.38	11.97	53.35	54.00	-0.65	AVG	

REMARKS:

- (1) Measurement Value = Reading Level + Correct Factor.
- (2) Margin Level = Measurement Value - Limit Value.

Test Mode	UNII-2A_TX AC(VHT80) Mode 5290 MHz	Polarization	Horizontal
-----------	------------------------------------	--------------	------------

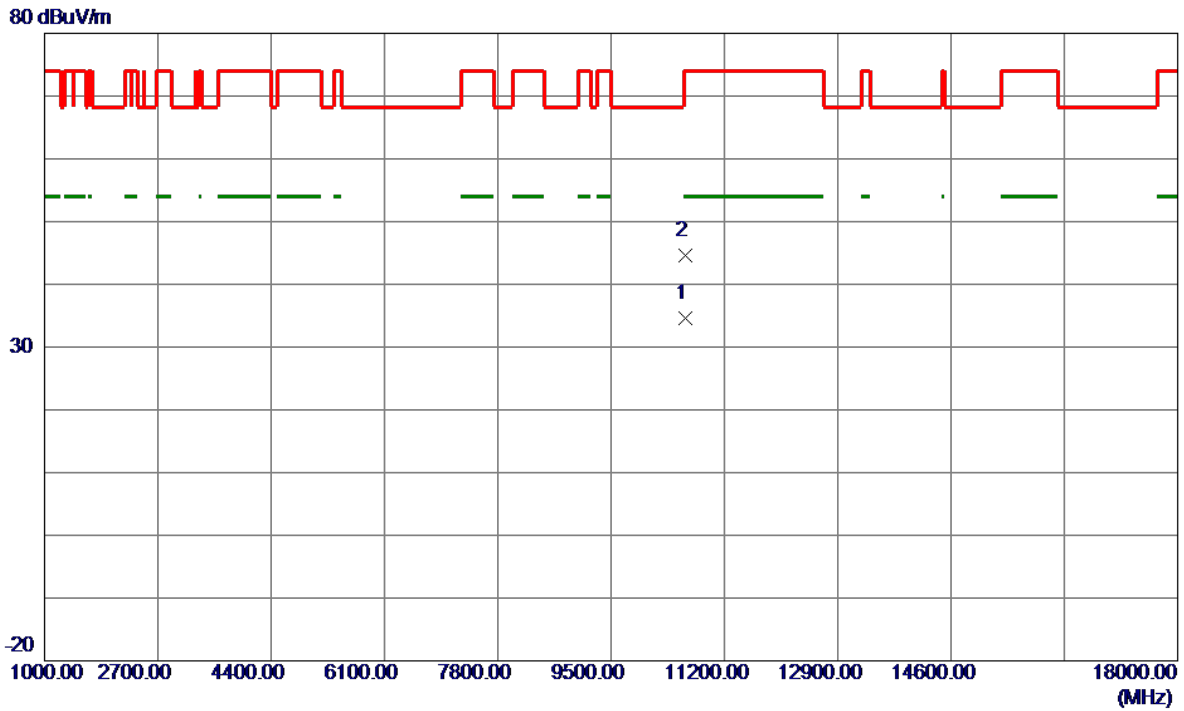

No.	Freq. MHz	Reading Level dBuV/m	Correct Factor dB	Measure ment dBuV/m	Limit dBuV/m	Margin dB	Detector	Comment
1 *	10611.5000	26.89	7.74	34.63	54.00	-19.37	AVG	
2	10618.1500	36.77	7.75	44.52	74.00	-29.48	Peak	

REMARKS:

- (1) Measurement Value = Reading Level + Correct Factor.
- (2) Margin Level = Measurement Value - Limit Value.

Test Mode	UNII-2A_TX AX(HE20) Mode 5260 MHz	Polarization	Horizontal
-----------	-----------------------------------	--------------	------------

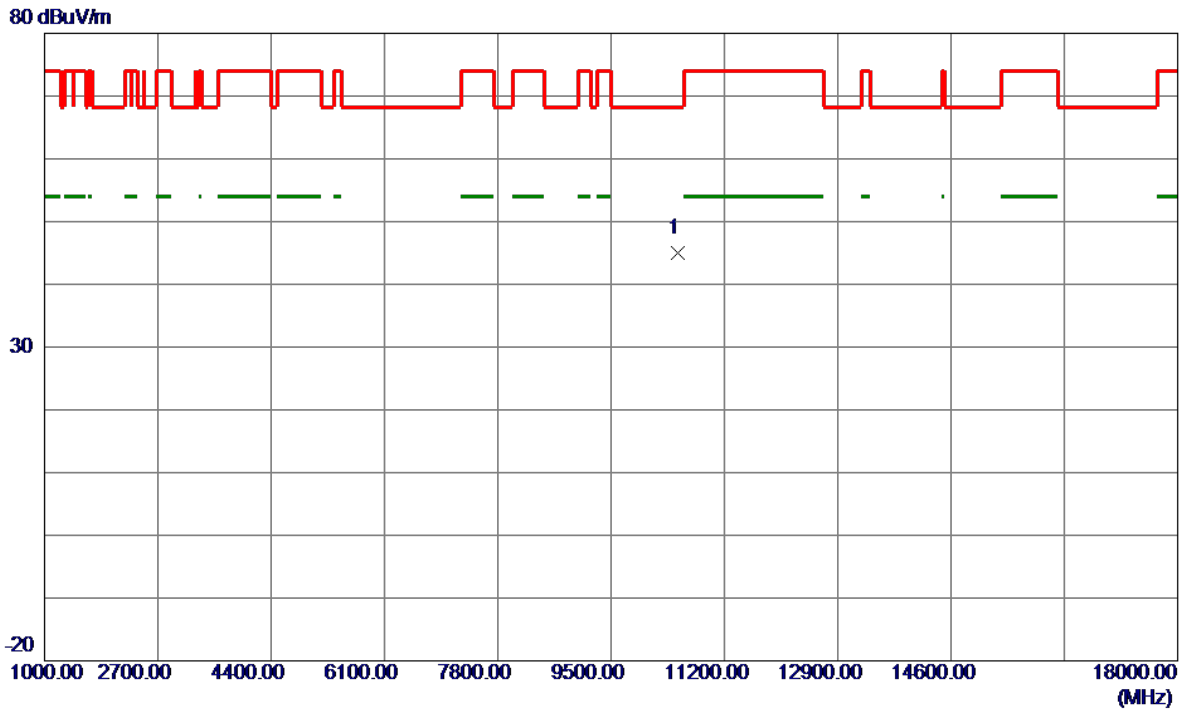

No.	Freq. MHz	Reading Level dBuV/m	Correct Factor dB	Measure ment dBuV/m	Limit dBuV/m	Margin dB	Detector	Comment
1 *	10507.0750	37.27	7.67	44.94	68.20	-23.26	Peak	

REMARKS:

- (1) Measurement Value = Reading Level + Correct Factor.
- (2) Margin Level = Measurement Value - Limit Value.

Test Mode	UNII-2A_TX AX(HE20) Mode 5300 MHz	Polarization	Vertical
-----------	-----------------------------------	--------------	----------

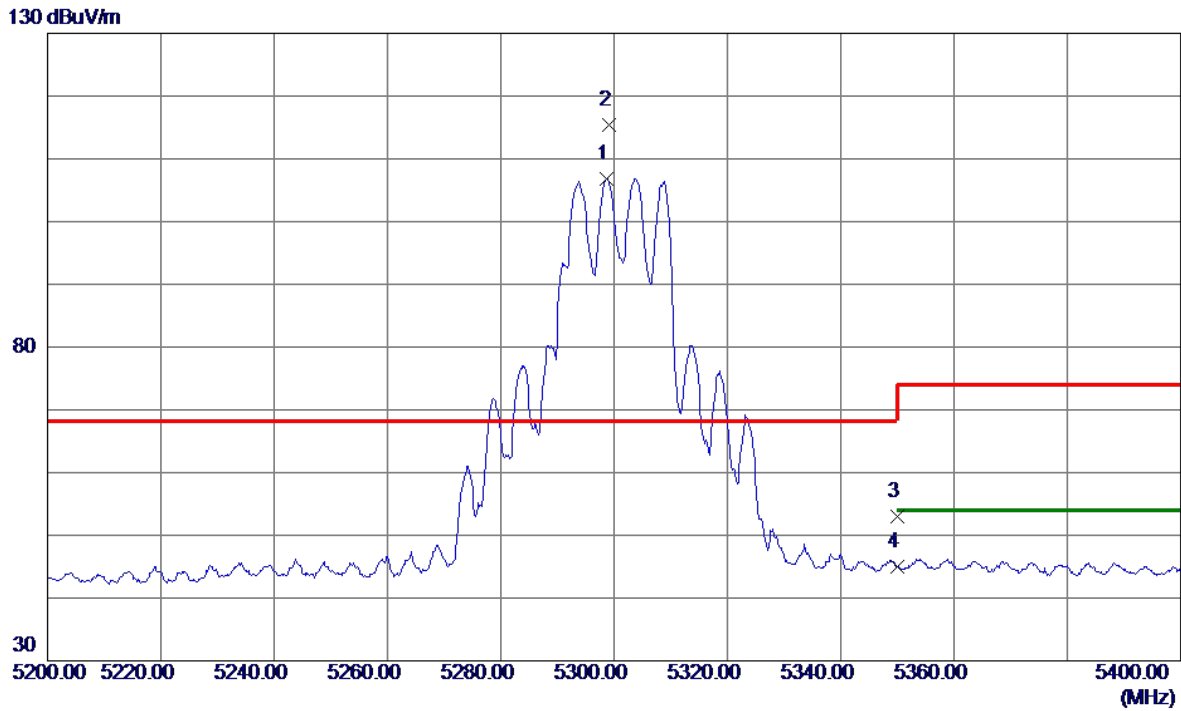

No.	Freq. MHz	Reading Level dBuV/m	Correct Factor dB	Measure ment dBuV/m	Limit dBuV/m	Margin dB	Detector	Comment
1	5298.7000	95.03	11.85	106.88	999.00	-892.12	AVG	No Limit
2 *	5299.2000	103.53	11.85	115.38	68.20	47.18	Peak	No Limit
3	5350.0000	41.03	11.96	52.99	74.00	-21.01	Peak	
4	5350.0000	33.09	11.96	45.05	54.00	-8.95	AVG	

REMARKS:

- (1) Measurement Value = Reading Level + Correct Factor.
- (2) Margin Level = Measurement Value - Limit Value.

Test Mode	UNII-2A_TX AX(HE20) Mode 5300 MHz	Polarization	Horizontal
-----------	-----------------------------------	--------------	------------

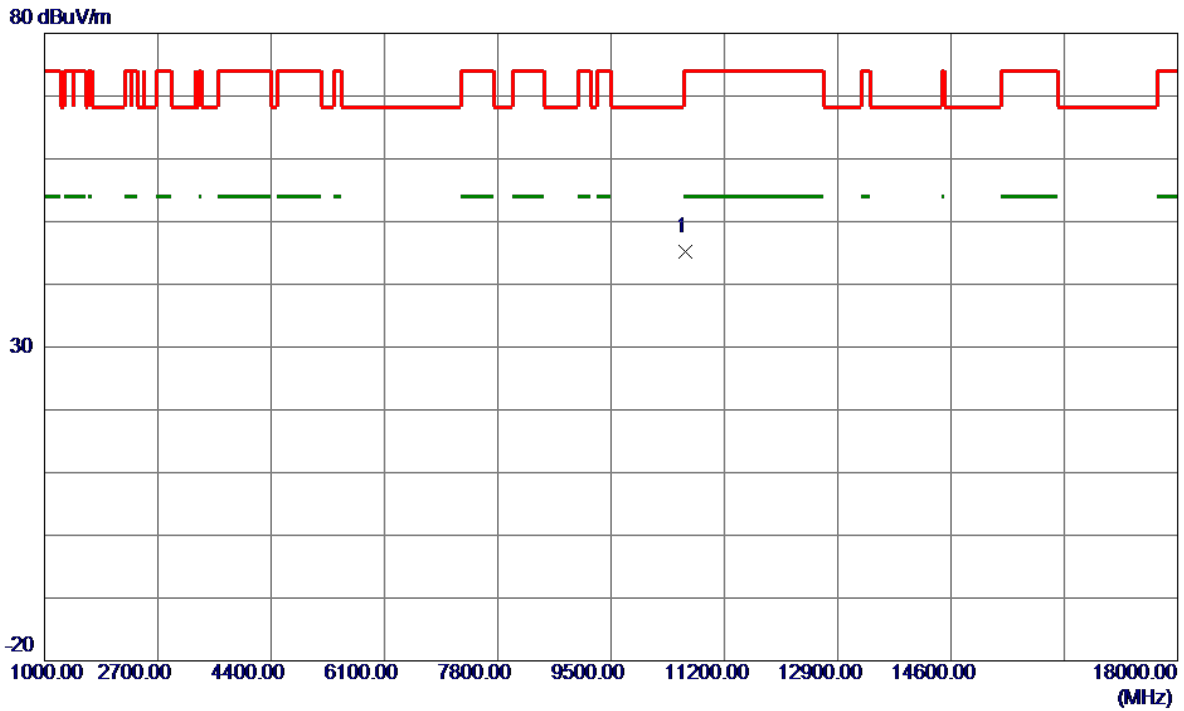

No.	Freq. MHz	Reading Level dBuV/m	Correct Factor dB	Measure ment dBuV/m	Limit dBuV/m	Margin dB	Detector	Comment
1 *	10608.5500	37.37	7.74	45.11	74.00	-28.89	Peak	

REMARKS:

- (1) Measurement Value = Reading Level + Correct Factor.
- (2) Margin Level = Measurement Value - Limit Value.

Test Mode	UNII-2A_TX AX(HE20) Mode 5320 MHz	Polarization	Vertical
-----------	-----------------------------------	--------------	----------

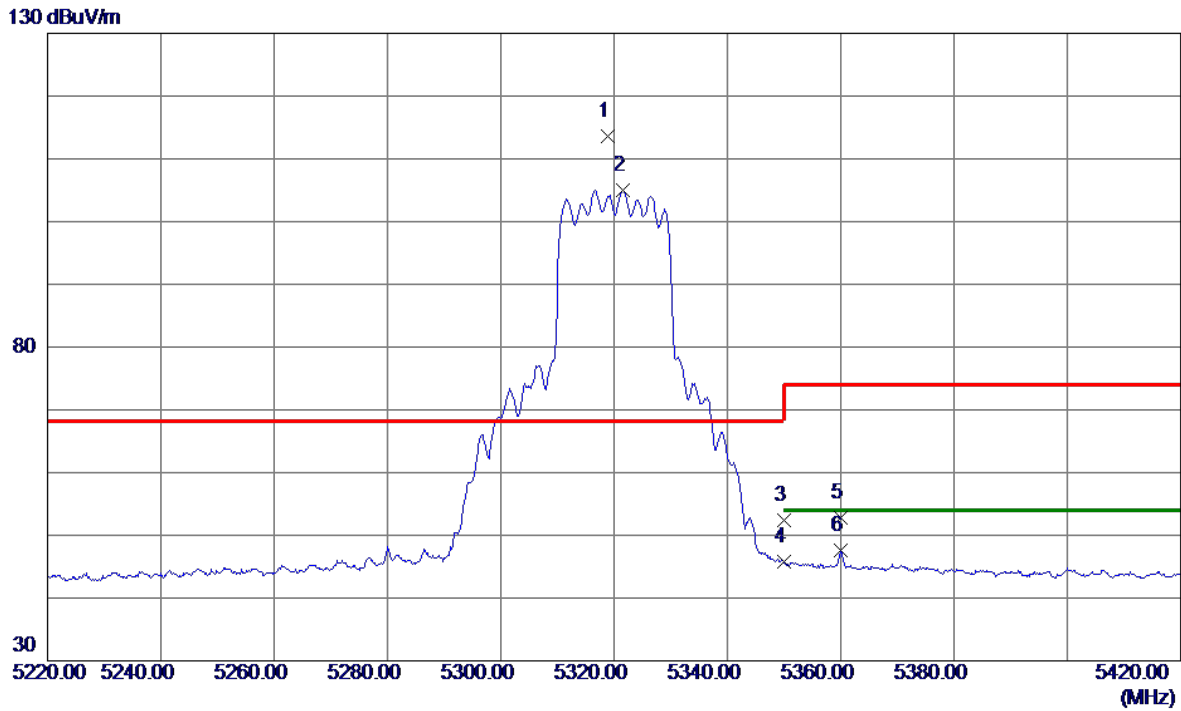

No.	Freq. MHz	Reading Level dBuV/m	Correct Factor dB	Measure ment dBuV/m	Limit dBuV/m	Margin dB	Detector	Comment
1 *	5318.8000	101.69	11.89	113.58	68.20	45.38	Peak	No Limit
2	5321.6000	93.03	11.90	104.93	999.00	-894.07	AVG	No Limit
3	5350.0000	40.44	11.96	52.40	74.00	-21.60	Peak	
4	5350.0000	33.75	11.96	45.71	54.00	-8.29	AVG	
5	5360.0000	40.83	11.98	52.81	74.00	-21.19	Peak	
6	5360.0000	35.54	11.98	47.52	54.00	-6.48	AVG	

REMARKS:

- (1) Measurement Value = Reading Level + Correct Factor.
- (2) Margin Level = Measurement Value - Limit Value.

Test Mode	UNII-2A_TX AX(HE20) Mode 5320 MHz	Polarization	Horizontal
-----------	-----------------------------------	--------------	------------

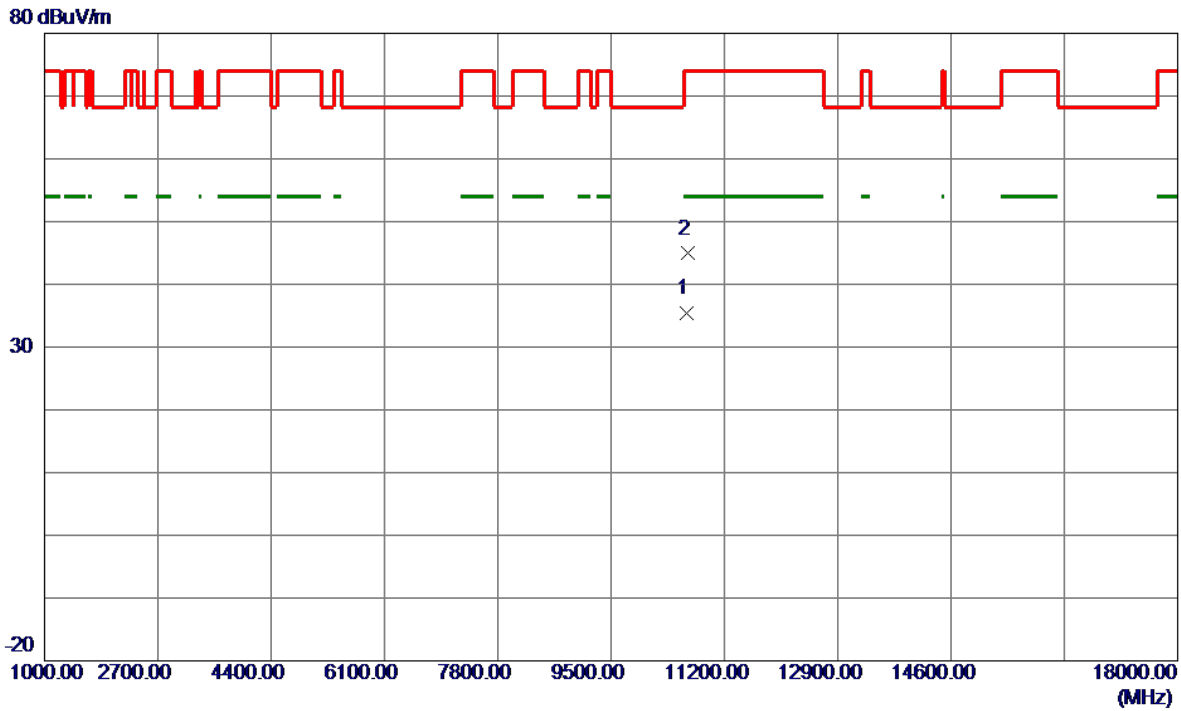

No.	Freq. MHz	Reading Level dBuV/m	Correct Factor dB	Measure ment dBuV/m	Limit dBuV/m	Margin dB	Detector	Comment
1 *	10634.1250	27.71	7.76	35.47	54.00	-18.53	AVG	
2	10645.0000	37.13	7.77	44.90	74.00	-29.10	Peak	

REMARKS:

- (1) Measurement Value = Reading Level + Correct Factor.
- (2) Margin Level = Measurement Value - Limit Value.

Test Mode	UNII-2A_TX AX(HE40) Mode 5270 MHz	Polarization	Vertical
-----------	-----------------------------------	--------------	----------

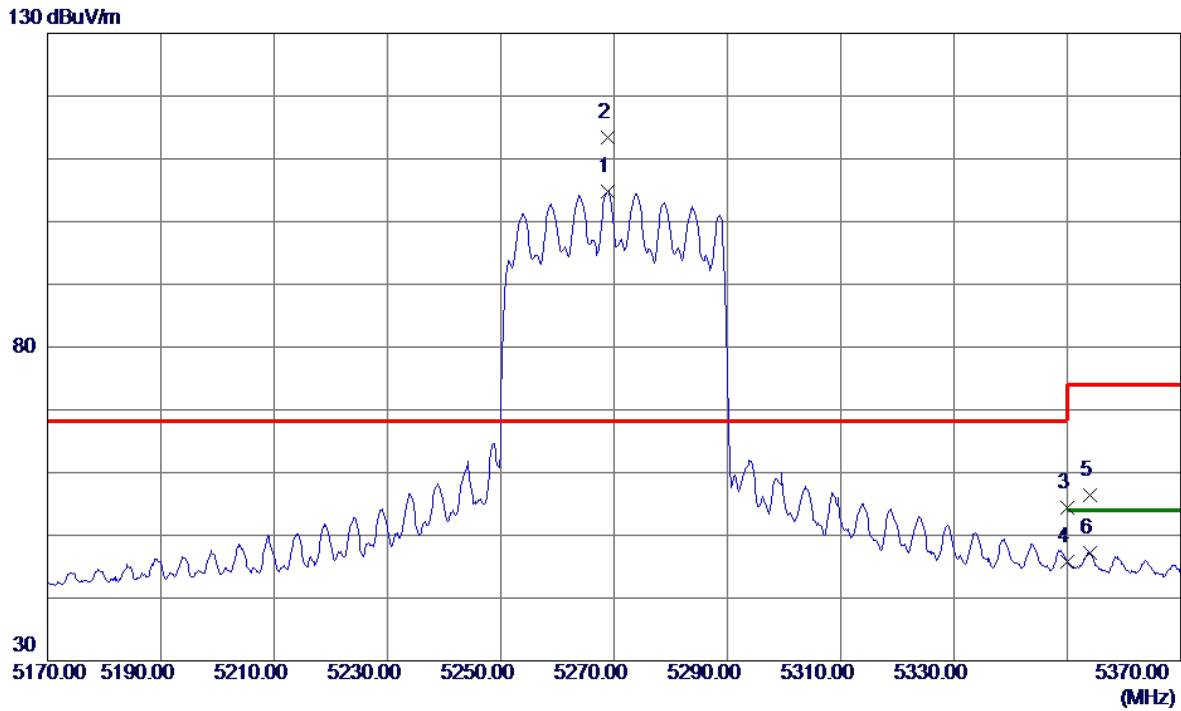

No.	Freq. MHz	Reading Level dBuV/m	Correct Factor dB	Measure ment dBuV/m	Limit dBuV/m	Margin dB	Detector	Comment
1	5268.8000	92.99	11.79	104.78	999.00	-894.22	AVG	No Limit
2 *	5268.9000	101.68	11.79	113.47	68.20	45.27	Peak	No Limit
3	5350.0000	42.40	11.96	54.36	74.00	-19.64	Peak	
4	5350.0000	33.84	11.96	45.80	54.00	-8.20	AVG	
5	5354.0000	44.36	11.97	56.33	74.00	-17.67	Peak	
6	5354.0000	35.19	11.97	47.16	54.00	-6.84	AVG	

REMARKS:

- (1) Measurement Value = Reading Level + Correct Factor.
- (2) Margin Level = Measurement Value - Limit Value.

Test Mode	UNII-2A_TX AX(HE40) Mode 5270 MHz	Polarization	Horizontal
-----------	-----------------------------------	--------------	------------

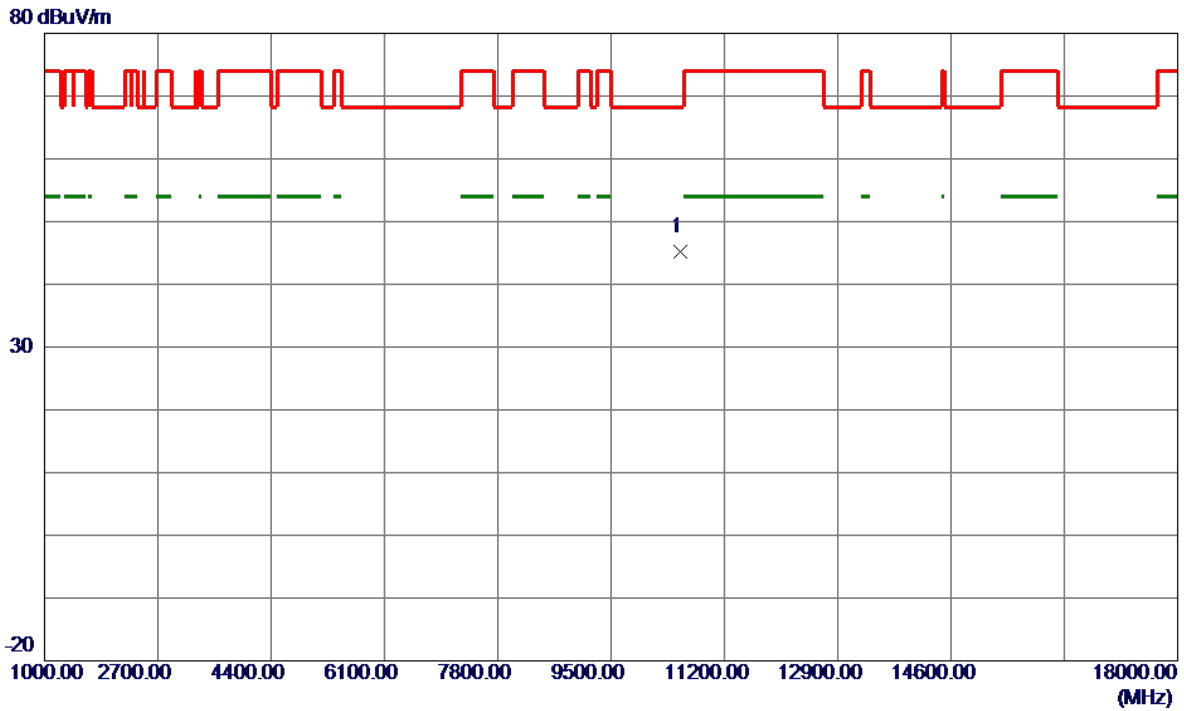

No.	Freq. MHz	Reading Level dBuV/m	Correct Factor dB	Measure ment dBuV/m	Limit dBuV/m	Margin dB	Detector	Comment
1 *	10547.3500	37.45	7.69	45.14	68.20	-23.06	Peak	

REMARKS:

- (1) Measurement Value = Reading Level + Correct Factor.
- (2) Margin Level = Measurement Value - Limit Value.

Test Mode	UNII-2A_TX AX(HE40) Mode 5310 MHz	Polarization	Vertical
-----------	-----------------------------------	--------------	----------

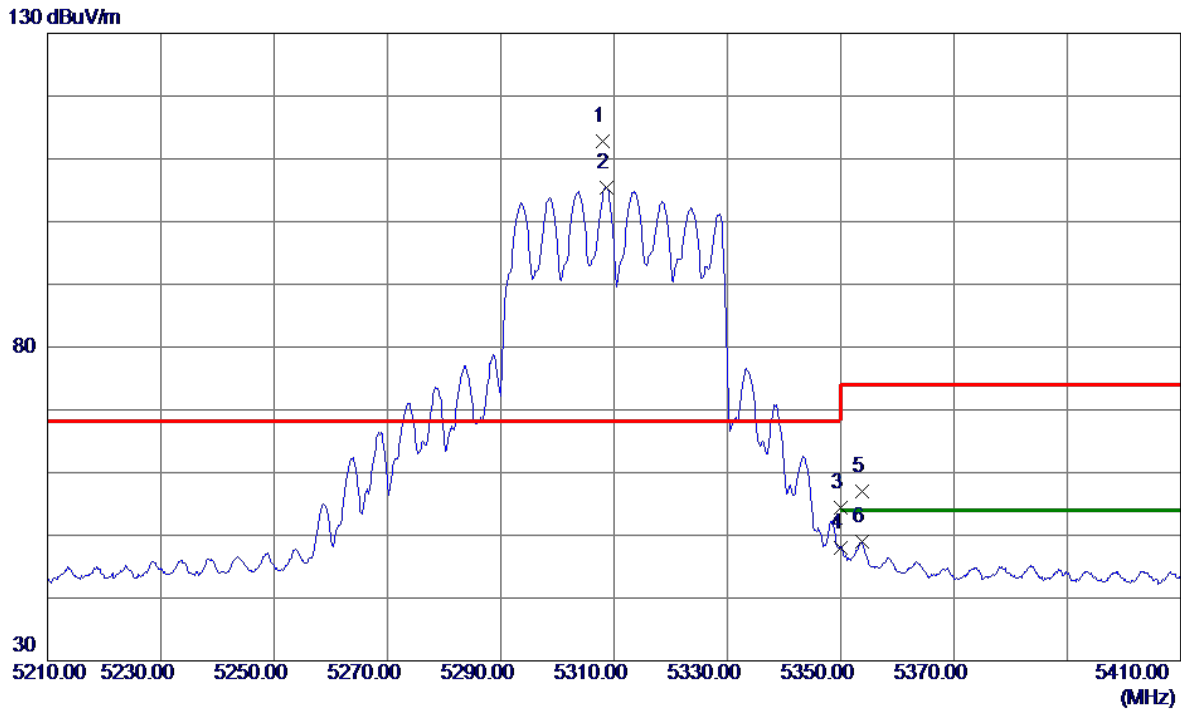

No.	Freq. MHz	Reading Level dBuV/m	Correct Factor dB	Measure ment dBuV/m	Limit dBuV/m	Margin dB	Detector	Comment
1 *	5308.0000	101.01	11.87	112.88	68.20	44.68	Peak	No Limit
2	5308.7000	93.52	11.87	105.39	999.00	-893.61	AVG	No Limit
3	5350.0000	42.42	11.96	54.38	74.00	-19.62	Peak	
4	5350.0000	36.01	11.96	47.97	54.00	-6.03	AVG	
5	5353.7000	45.01	11.97	56.98	74.00	-17.02	Peak	
6	5353.7000	36.96	11.97	48.93	54.00	-5.07	AVG	

REMARKS:

- (1) Measurement Value = Reading Level + Correct Factor.
- (2) Margin Level = Measurement Value - Limit Value.

Test Mode	UNII-2A_TX AX(HE40) Mode 5310 MHz	Polarization	Horizontal
-----------	-----------------------------------	--------------	------------

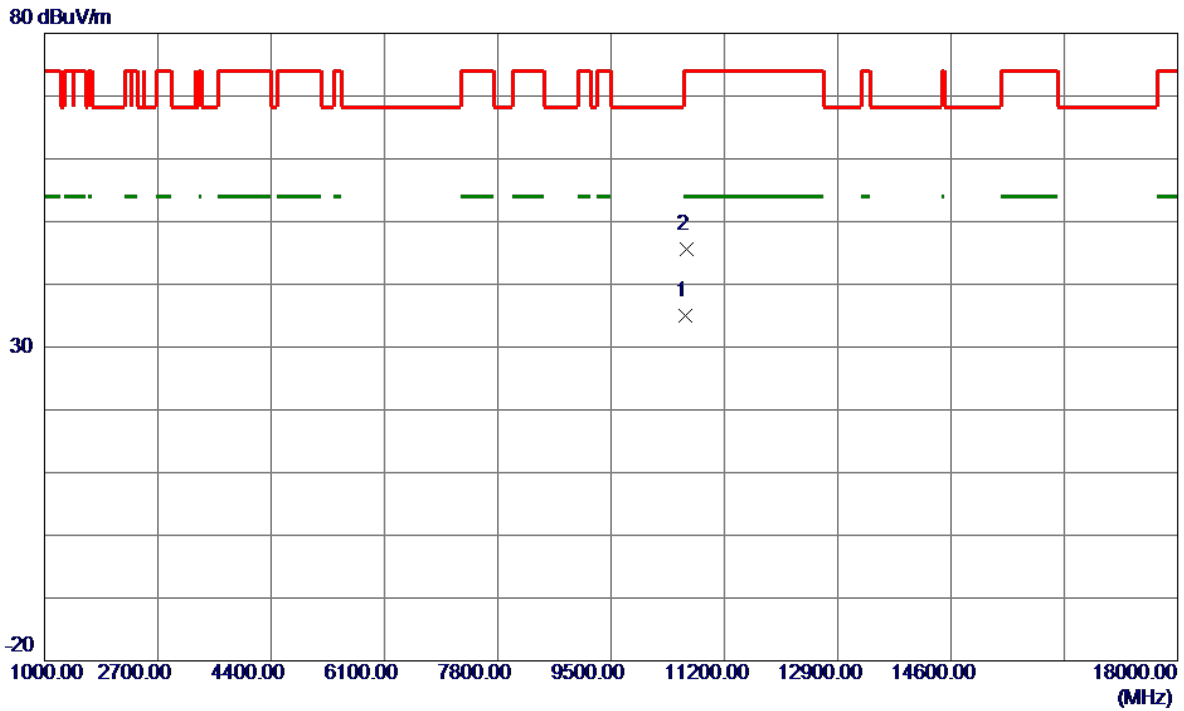

No.	Freq. MHz	Reading Level dBuV/m	Correct Factor dB	Measure ment dBuV/m	Limit dBuV/m	Margin dB	Detector	Comment
1 *	10618.9750	27.30	7.75	35.05	54.00	-18.95	AVG	
2	10635.7500	37.81	7.76	45.57	74.00	-28.43	Peak	

REMARKS:

- (1) Measurement Value = Reading Level + Correct Factor.
- (2) Margin Level = Measurement Value - Limit Value.

Test Mode	UNII-2A_TX AX(HE80) Mode 5290 MHz	Polarization	Vertical
-----------	-----------------------------------	--------------	----------

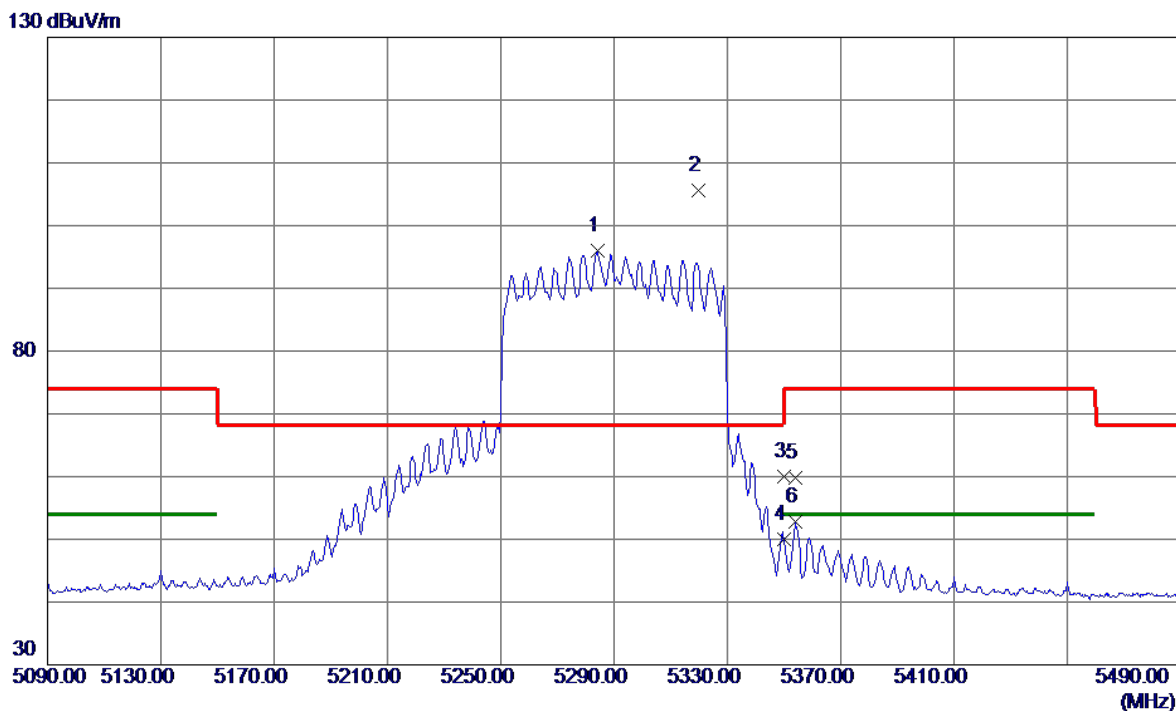

No.	Freq. MHz	Reading Level dBuV/m	Correct Factor dB	Measure ment dBuV/m	Limit dBuV/m	Margin dB	Detector	Comment
1	5284.2000	84.26	11.82	96.08	999.00	-902.92	AVG	No Limit
2 *	5319.6000	93.66	11.89	105.55	68.20	37.35	Peak	No Limit
3	5350.0000	48.01	11.96	59.97	74.00	-14.03	Peak	
4	5350.0000	38.06	11.96	50.02	54.00	-3.98	AVG	
5	5353.8000	47.79	11.97	59.76	74.00	-14.24	Peak	
6	5353.8000	40.85	11.97	52.82	54.00	-1.18	AVG	

REMARKS:

- (1) Measurement Value = Reading Level + Correct Factor.
- (2) Margin Level = Measurement Value - Limit Value.

Test Mode	UNII-2A_TX AX(HE80) Mode 5290 MHz	Polarization	Horizontal
-----------	-----------------------------------	--------------	------------

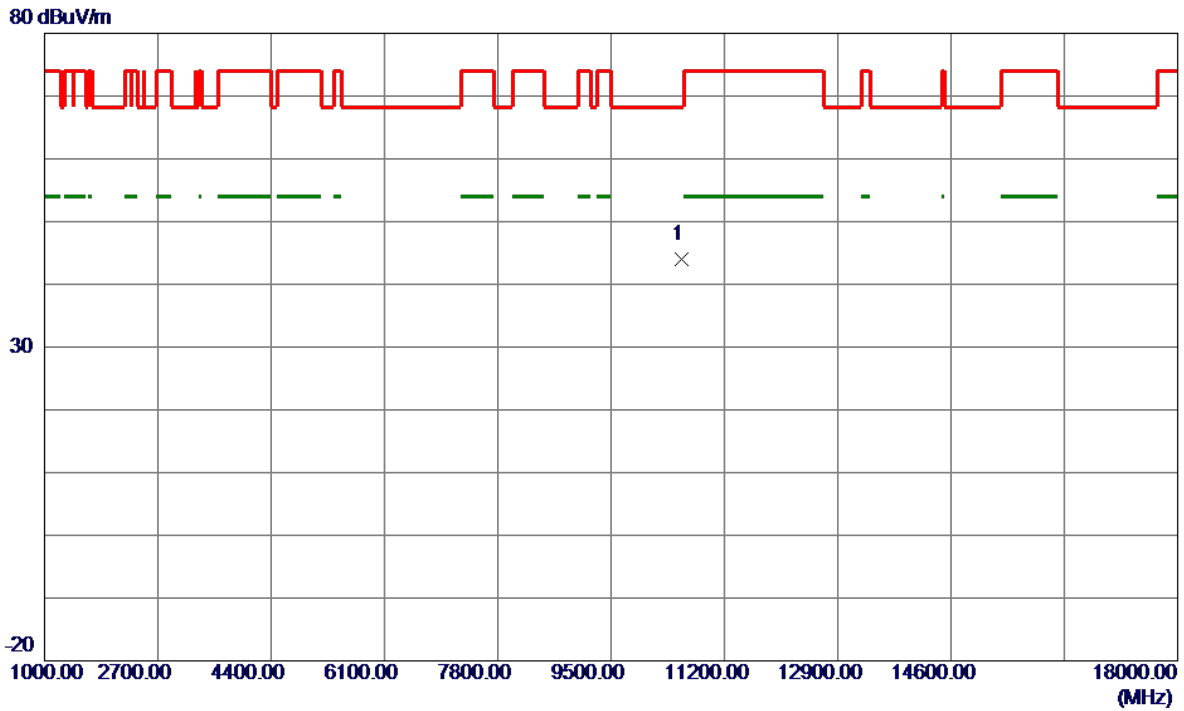

No.	Freq. MHz	Reading Level dBuV/m	Correct Factor dB	Measure ment dBuV/m	Limit dBuV/m	Margin dB	Detector	Comment
1 *	10548.8000	36.38	7.70	44.08	68.20	-24.12	Peak	

REMARKS:

- (1) Measurement Value = Reading Level + Correct Factor.
- (2) Margin Level = Measurement Value - Limit Value.

Test Mode	UNII-1+UNII-2A_TX AC(VHT160) Mode 5250 MHz	Polarization	Vertical
-----------	--	--------------	----------

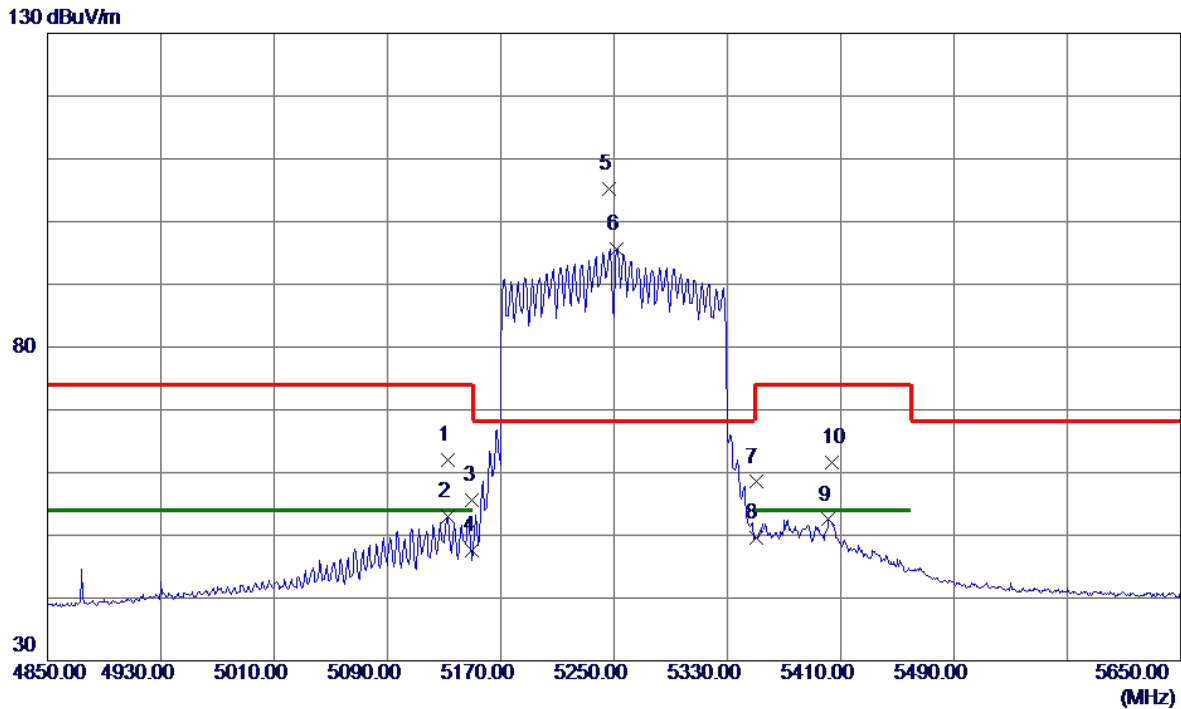

No.	Freq. MHz	Reading Level dBuV/m	Correct Factor dB	Measure ment dBuV/m	Limit dBuV/m	Margin dB	Detector	Comment
1	5132.4000	50.45	11.50	61.95	74.00	-12.05	Peak	
2	5132.4000	41.51	11.50	53.01	54.00	-0.99	AVG	
3	5150.0000	44.02	11.54	55.56	74.00	-18.44	Peak	
4	5150.0000	36.11	11.54	47.65	54.00	-6.35	AVG	
5 *	5246.4000	93.55	11.74	105.29	68.20	37.09	Peak	No Limit
6	5252.0000	83.84	11.75	95.59	999.00	-903.41	AVG	No Limit
7	5350.0000	46.54	11.96	58.50	74.00	-15.50	Peak	
8	5350.0000	37.66	11.96	49.62	54.00	-4.38	AVG	
9	5401.2000	40.43	12.07	52.50	54.00	-1.50	AVG	
10	5404.0000	49.53	12.07	61.60	74.00	-12.40	Peak	

REMARKS:

- (1) Measurement Value = Reading Level + Correct Factor.
- (2) Margin Level = Measurement Value - Limit Value.

Test Mode	UNII-1+UNII-2A_TX AC(VHT160) Mode 5250 MHz	Polarization	Horizontal
-----------	--	--------------	------------

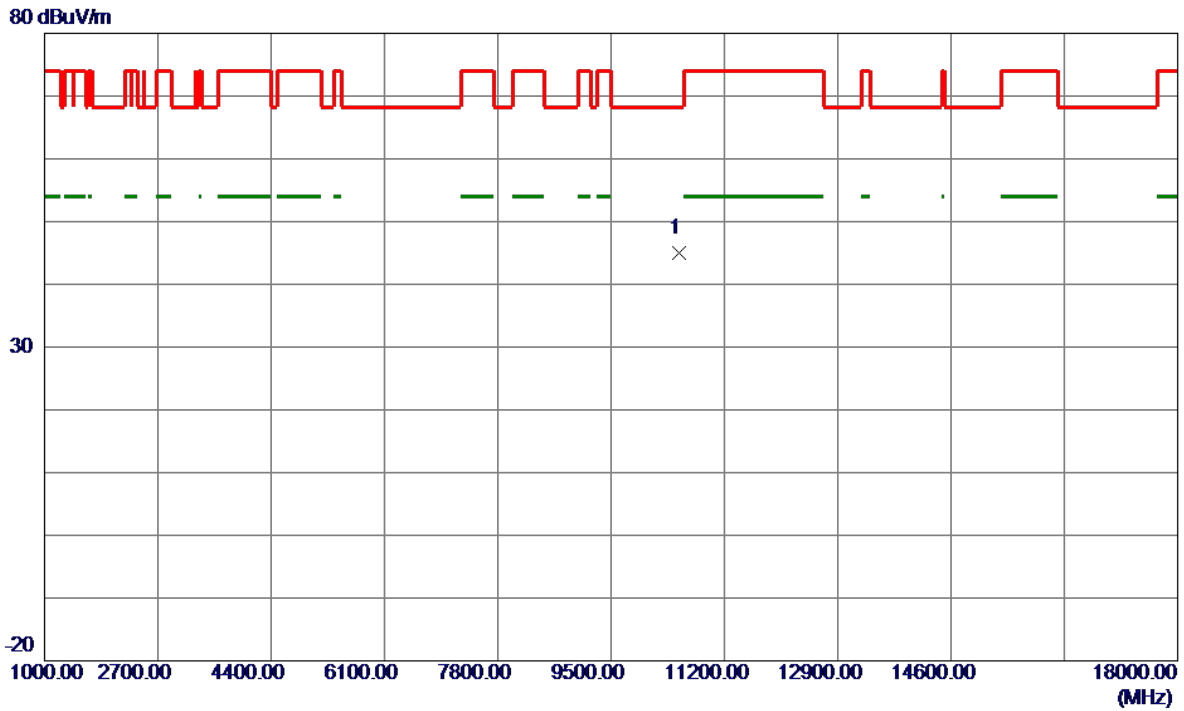

No.	Freq. MHz	Reading Level dBuV/m	Correct Factor dB	Measure ment dBuV/m	Limit dBuV/m	Margin dB	Detector	Comment
1 *	10519.3500	37.36	7.67	45.03	68.20	-23.17	Peak	

REMARKS:

- (1) Measurement Value = Reading Level + Correct Factor.
- (2) Margin Level = Measurement Value - Limit Value.

Test Mode	UNII-1+UNII-2A_TX AX(HE160) Mode 5250 MHz	Polarization	Vertical
-----------	---	--------------	----------

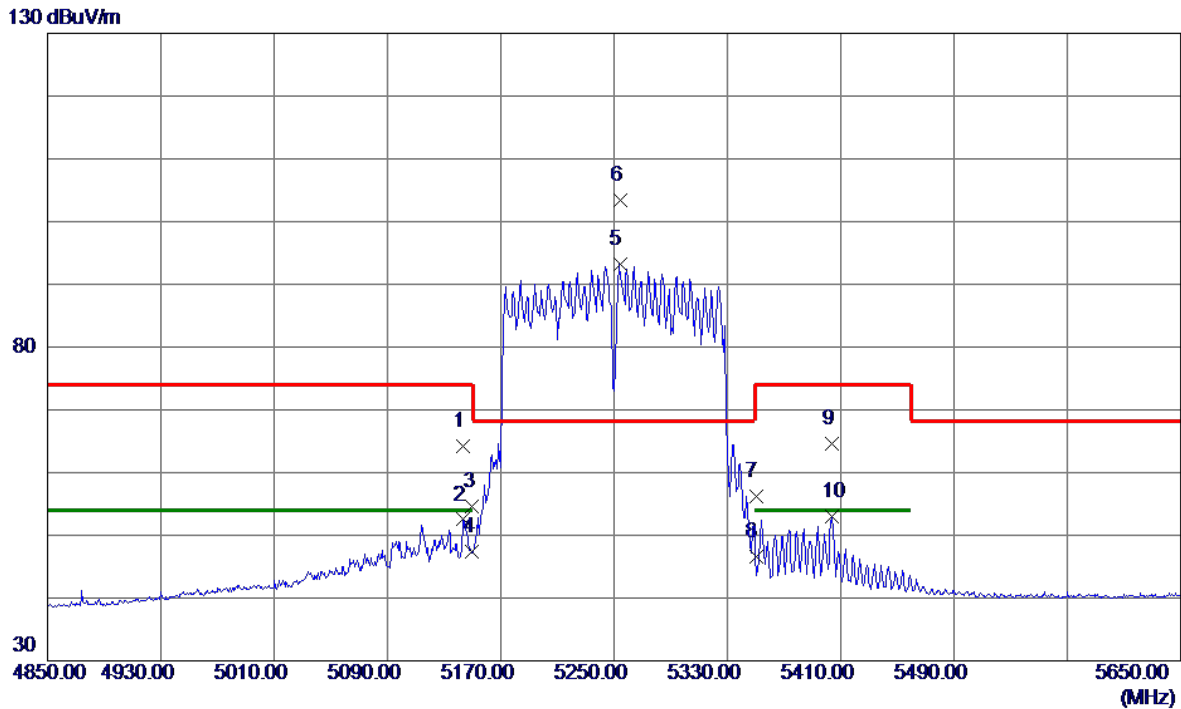

No.	Freq. MHz	Reading Level dBuV/m	Correct Factor dB	Measure ment dBuV/m	Limit dBuV/m	Margin dB	Detector	Comment
1	5143.6000	52.64	11.52	64.16	74.00	-9.84	Peak	
2	5143.6000	40.98	11.52	52.50	54.00	-1.50	AVG	
3	5150.0000	43.05	11.54	54.59	74.00	-19.41	Peak	
4	5150.0000	35.83	11.54	47.37	54.00	-6.63	AVG	
5	5254.0000	81.43	11.76	93.19	999.00	-905.81	AVG	No Limit
6 *	5254.8000	91.55	11.76	103.31	68.20	35.11	Peak	No Limit
7	5350.0000	44.28	11.96	56.24	74.00	-17.76	Peak	
8	5350.0000	34.62	11.96	46.58	54.00	-7.42	AVG	
9	5403.6000	52.55	12.07	64.62	74.00	-9.38	Peak	
10	5403.6000	40.87	12.07	52.94	54.00	-1.06	AVG	

REMARKS:

- (1) Measurement Value = Reading Level + Correct Factor.
- (2) Margin Level = Measurement Value - Limit Value.

Test Mode	UNII-1+UNII-2A_TX AX(HE160) Mode 5250 MHz	Polarization	Horizontal
-----------	---	--------------	------------

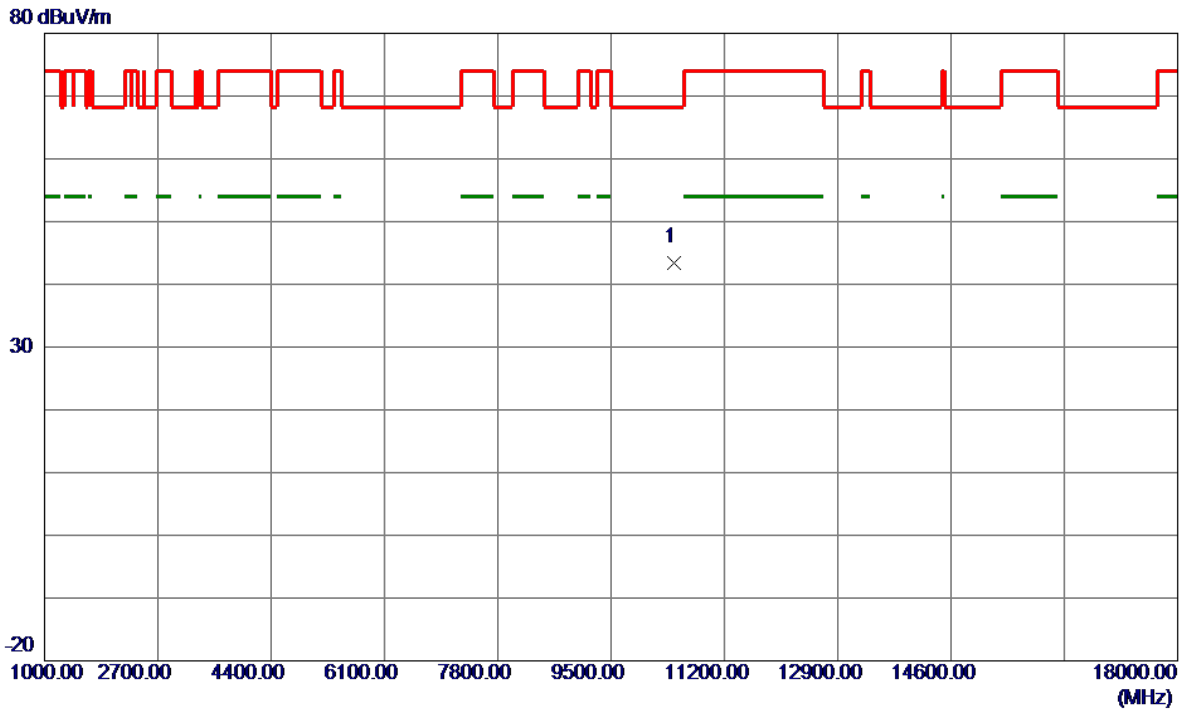

No.	Freq. MHz	Reading Level dBuV/m	Correct Factor dB	Measure ment dBuV/m	Limit dBuV/m	Margin dB	Detector	Comment
1 *	10445.9000	35.89	7.61	43.50	68.20	-24.70	Peak	

REMARKS:

- (1) Measurement Value = Reading Level + Correct Factor.
- (2) Margin Level = Measurement Value - Limit Value.

Test Mode	UNII-2C_TX A Mode 5500 MHz	Polarization	Vertical
-----------	----------------------------	--------------	----------

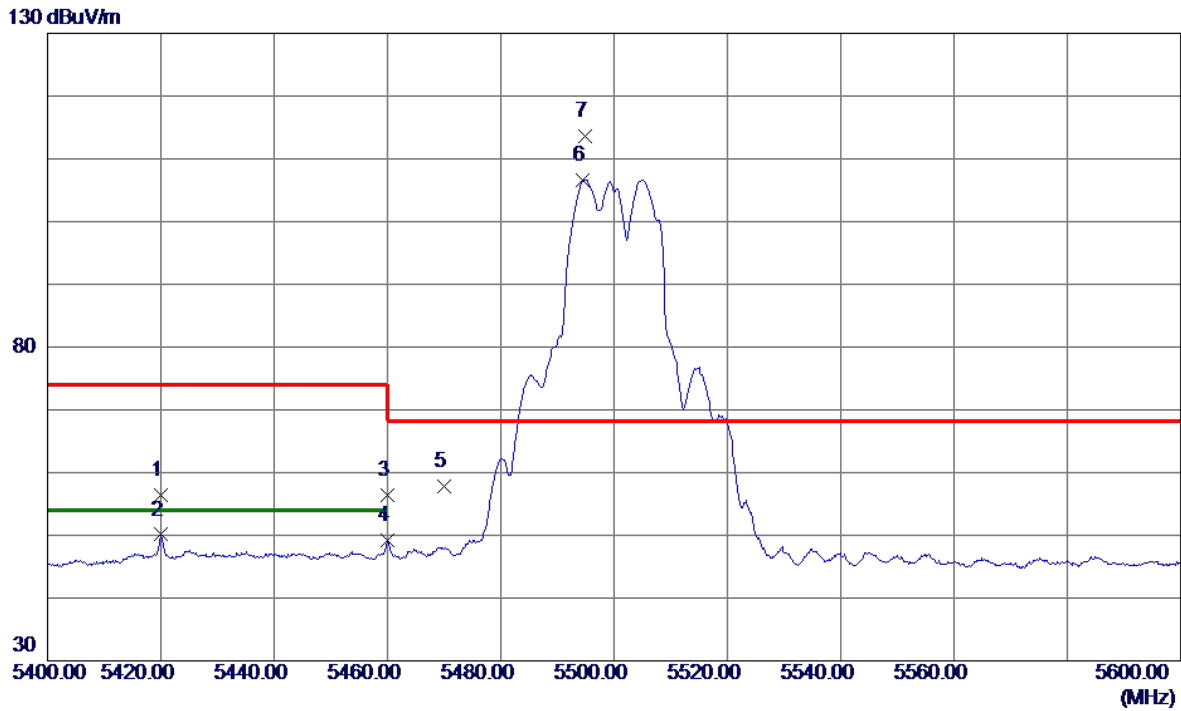

No.	Freq. MHz	Reading Level dBuV/m	Correct Factor dB	Measure ment dBuV/m	Limit dBuV/m	Margin dB	Detector	Comment
1	5420.0000	44.32	12.11	56.43	74.00	-17.57	Peak	
2	5420.0000	37.99	12.11	50.10	54.00	-3.90	AVG	
3	5460.0000	44.26	12.19	56.45	74.00	-17.55	Peak	
4	5460.0000	37.10	12.19	49.29	54.00	-4.71	AVG	
5	5470.0000	45.60	12.21	57.81	68.20	-10.39	Peak	
6	5494.5000	94.35	12.26	106.61	999.00	-892.39	AVG	No Limit
7 *	5494.8000	101.28	12.26	113.54	68.20	45.34	Peak	No Limit

REMARKS:

- (1) Measurement Value = Reading Level + Correct Factor.
- (2) Margin Level = Measurement Value - Limit Value.

Test Mode	UNII-2C_TX A Mode 5500 MHz	Polarization	Horizontal
-----------	----------------------------	--------------	------------

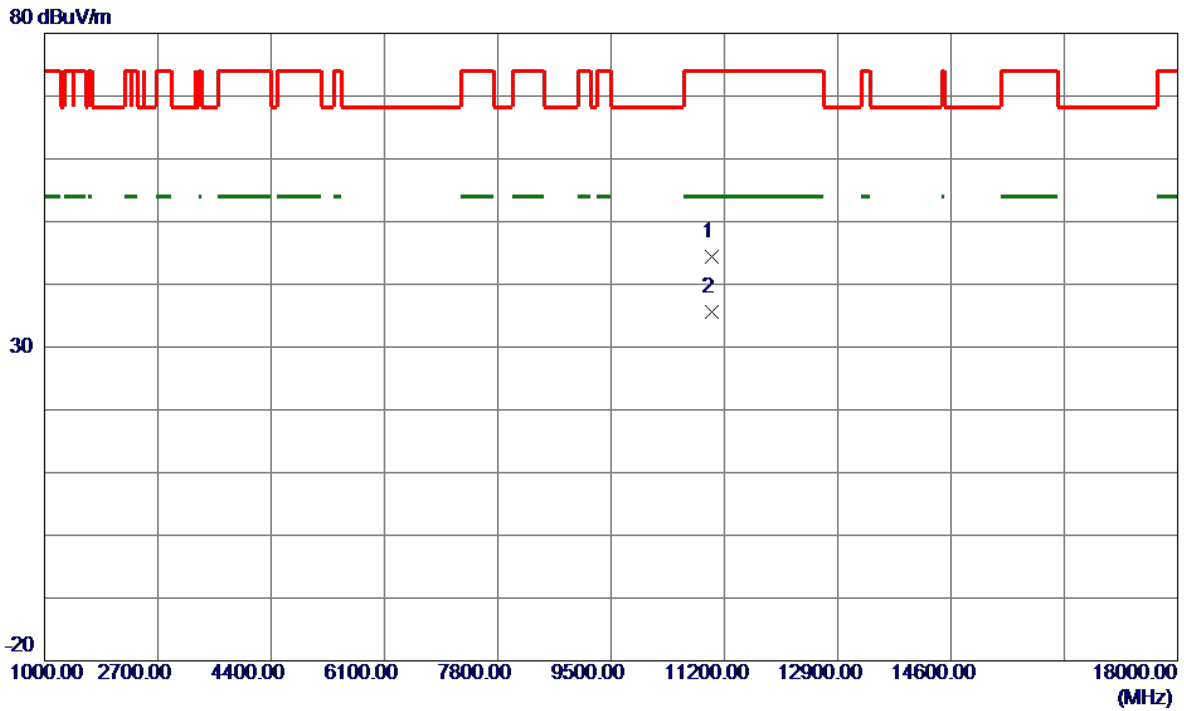

No.	Freq. MHz	Reading Level dBuV/m	Correct Factor dB	Measure ment dBuV/m	Limit dBuV/m	Margin dB	Detector	Comment
1	11003.5750	36.40	8.03	44.43	74.00	-29.57	Peak	
2 *	11004.9250	27.66	8.03	35.69	54.00	-18.31	AVG	

REMARKS:

- (1) Measurement Value = Reading Level + Correct Factor.
- (2) Margin Level = Measurement Value - Limit Value.

Test Mode	UNII-2C_TX A Mode 5580 MHz	Polarization	Horizontal
-----------	----------------------------	--------------	------------

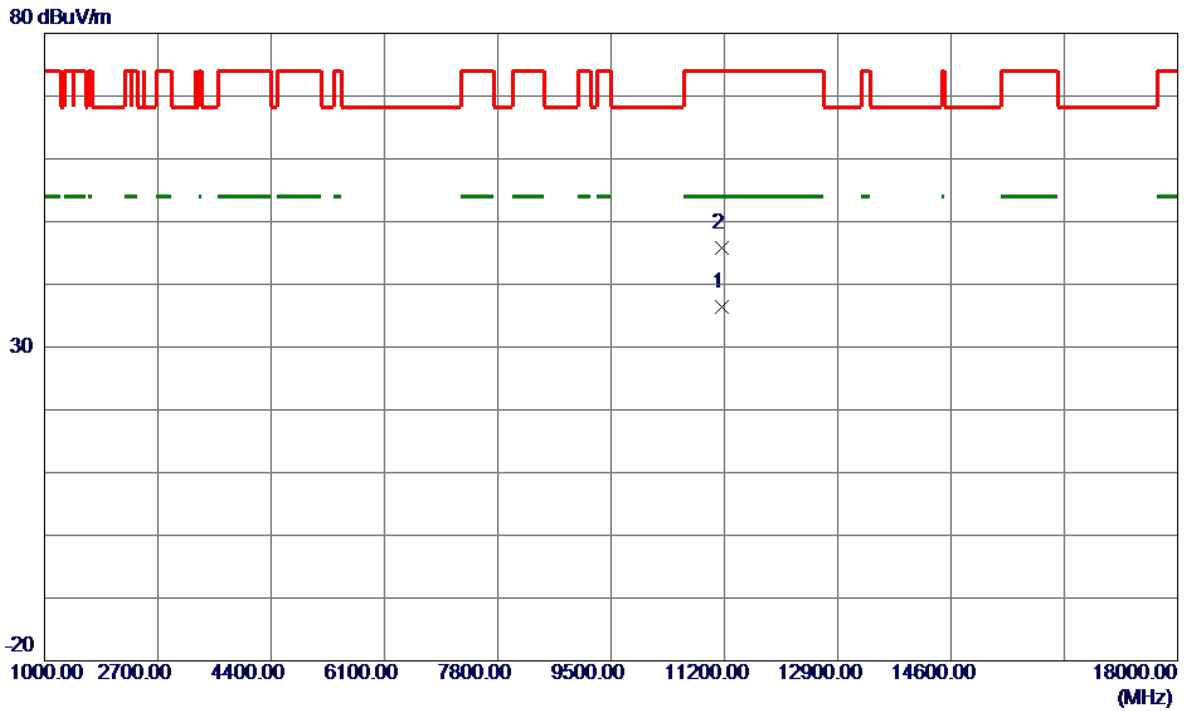

No.	Freq. MHz	Reading Level dBuV/m	Correct Factor dB	Measure ment dBuV/m	Limit dBuV/m	Margin dB	Detector	Comment
1 *	11154.9750	28.15	8.16	36.31	54.00	-17.69	AVG	
2	11155.4750	37.61	8.17	45.78	74.00	-28.22	Peak	

REMARKS:

- (1) Measurement Value = Reading Level + Correct Factor.
- (2) Margin Level = Measurement Value - Limit Value.

Test Mode	UNII-2C_TX A Mode 5700 MHz	Polarization	Vertical
-----------	----------------------------	--------------	----------

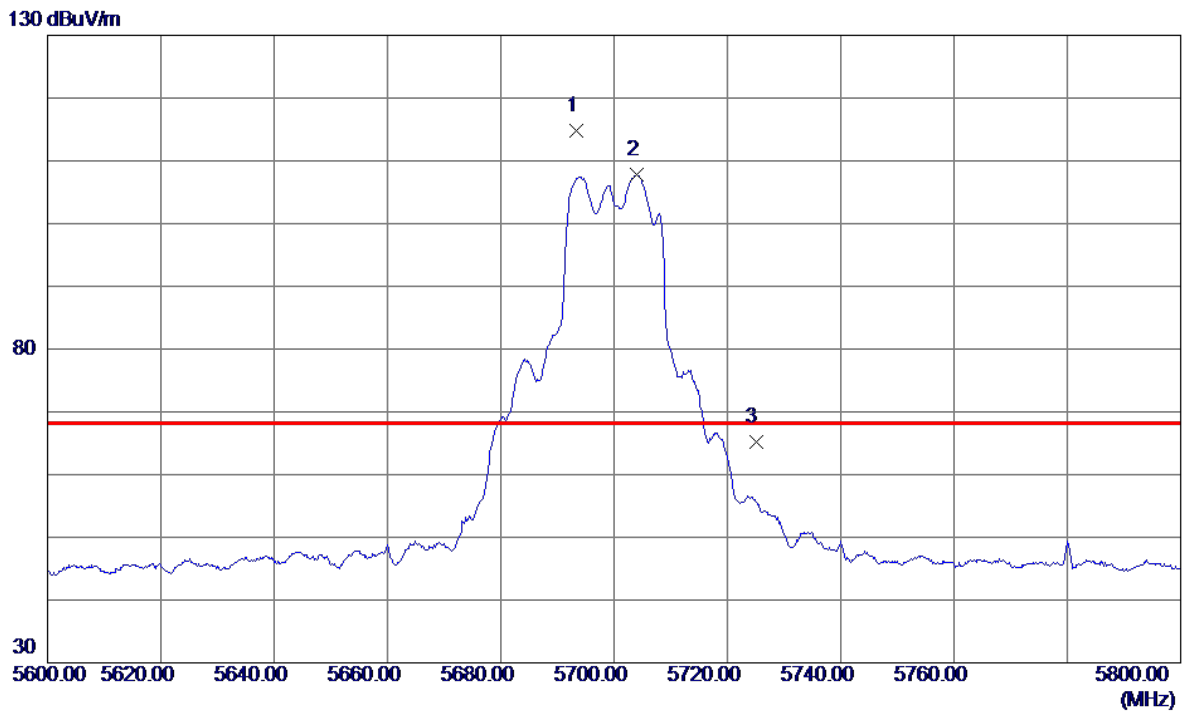

No.	Freq. MHz	Reading Level dBuV/m	Correct Factor dB	Measure ment dBuV/m	Limit dBuV/m	Margin dB	Detector	Comment
1 *	5693.4000	101.94	12.90	114.84	68.20	46.64	Peak	No Limit
2	5704.1000	94.82	12.93	107.75	999.00	-891.25	AVG	No Limit
3	5725.0000	52.13	13.00	65.13	68.20	-3.07	Peak	

REMARKS:

- (1) Measurement Value = Reading Level + Correct Factor.
- (2) Margin Level = Measurement Value - Limit Value.

Test Mode	UNII-2C_TX A Mode 5700 MHz	Polarization	Horizontal
-----------	----------------------------	--------------	------------

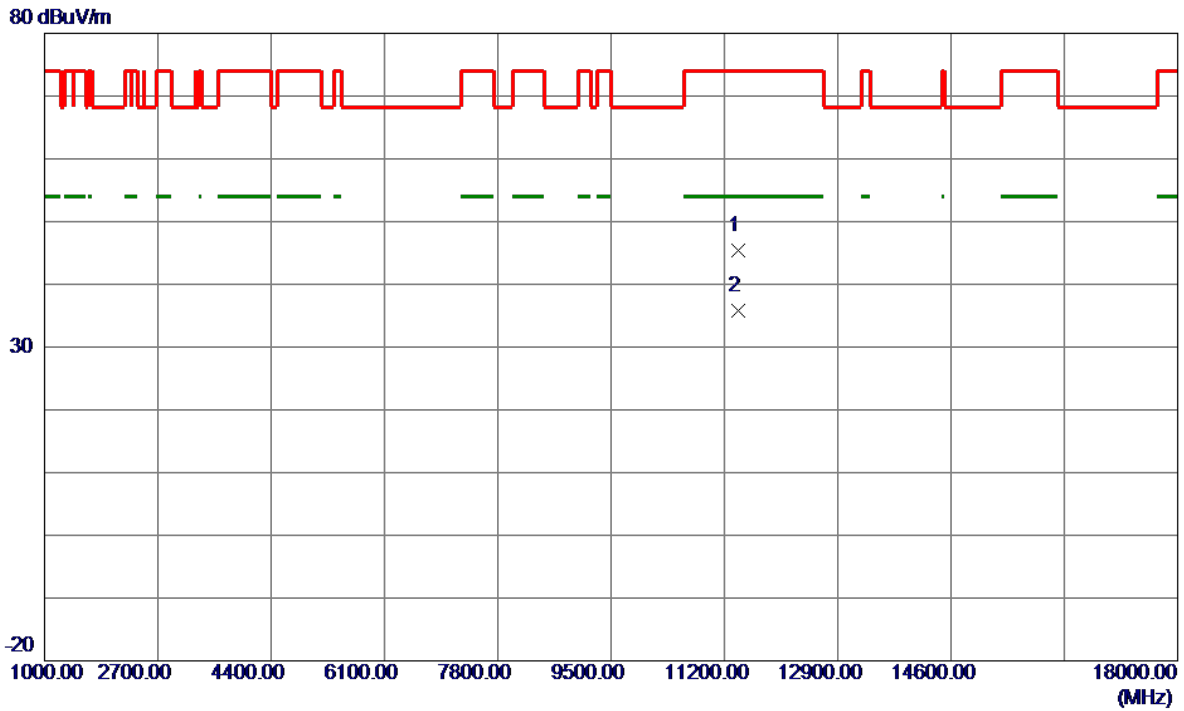

No.	Freq. MHz	Reading Level dBuV/m	Correct Factor dB	Measure ment dBuV/m	Limit dBuV/m	Margin dB	Detector	Comment
1	11404.8250	36.96	8.38	45.34	74.00	-28.66	Peak	
2 *	11404.8750	27.34	8.38	35.72	54.00	-18.28	AVG	

REMARKS:

- (1) Measurement Value = Reading Level + Correct Factor.
- (2) Margin Level = Measurement Value - Limit Value.

Test Mode	UNII-2C_TX AC(VHT20) Mode 5500 MHz	Polarization	Vertical
-----------	------------------------------------	--------------	----------

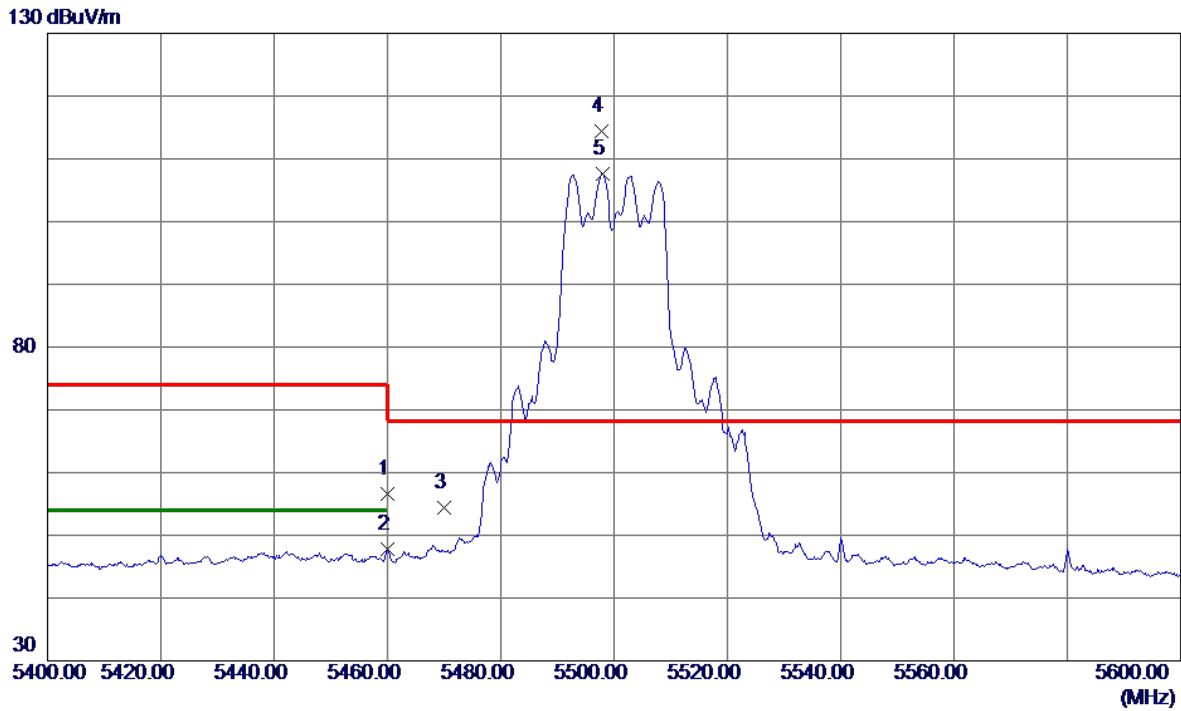

No.	Freq. MHz	Reading Level dBuV/m	Correct Factor dB	Measure ment dBuV/m	Limit dBuV/m	Margin dB	Detector	Comment
1	5460.0000	44.49	12.19	56.68	74.00	-17.32	Peak	
2	5460.0000	35.63	12.19	47.82	54.00	-6.18	AVG	
3	5470.0000	42.22	12.21	54.43	68.20	-13.77	Peak	
4 *	5497.8000	102.04	12.27	114.31	68.20	46.11	Peak	No Limit
5	5497.9000	95.37	12.27	107.64	999.00	-891.36	AVG	No Limit

REMARKS:

- (1) Measurement Value = Reading Level + Correct Factor.
- (2) Margin Level = Measurement Value - Limit Value.

Test Mode	UNII-2C_TX AC(VHT20) Mode 5500 MHz	Polarization	Horizontal
-----------	------------------------------------	--------------	------------

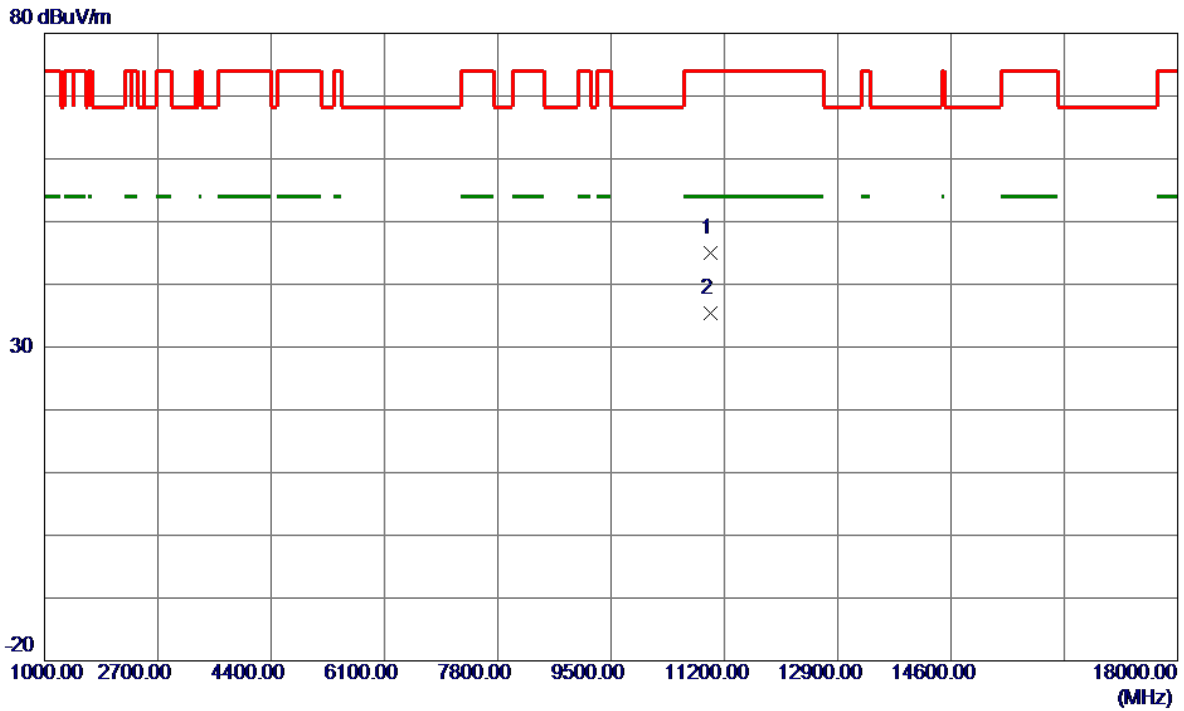

No.	Freq. MHz	Reading Level dBuV/m	Correct Factor dB	Measure ment dBuV/m	Limit dBuV/m	Margin dB	Detector	Comment
1	11000.7750	36.92	8.03	44.95	74.00	-29.05	Peak	
2 *	11001.2000	27.43	8.03	35.46	54.00	-18.54	AVG	

REMARKS:

- (1) Measurement Value = Reading Level + Correct Factor.
- (2) Margin Level = Measurement Value - Limit Value.

Test Mode	UNII-2C_TX AC(VHT20) Mode 5580 MHz	Polarization	Horizontal
-----------	------------------------------------	--------------	------------

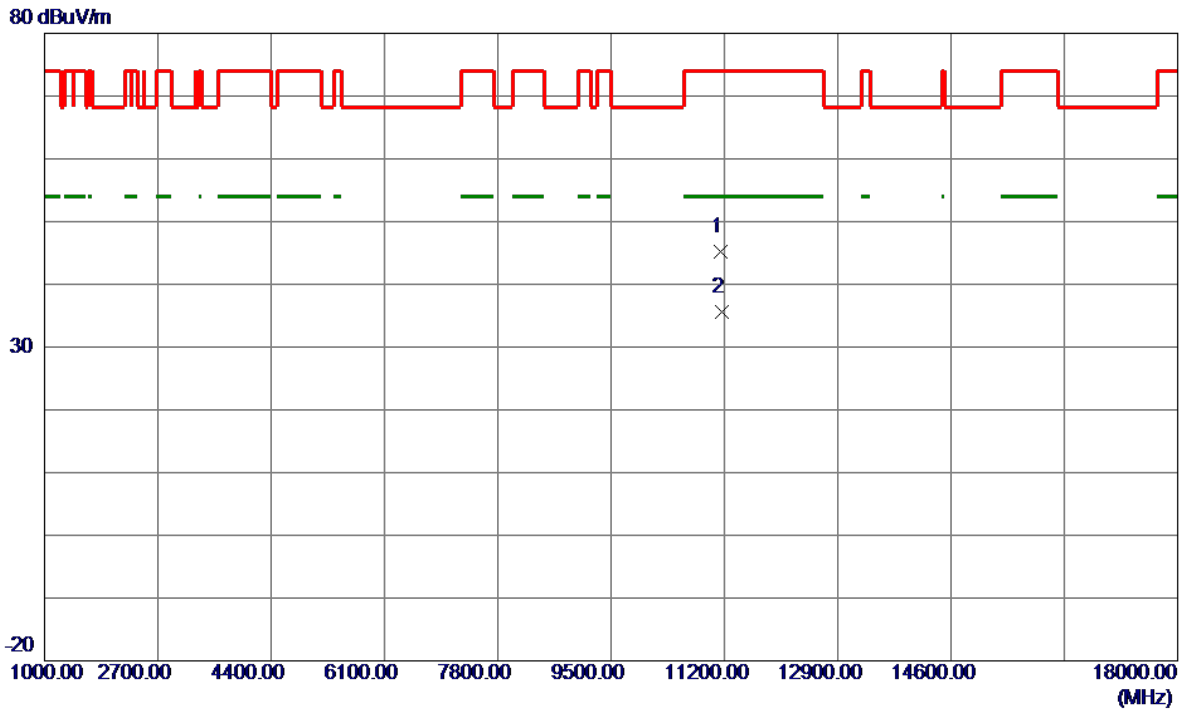

No.	Freq. MHz	Reading Level dBuV/m	Correct Factor dB	Measure ment dBuV/m	Limit dBuV/m	Margin dB	Detector	Comment
1	11148.7500	37.01	8.16	45.17	74.00	-28.83	Peak	
2 *	11161.0500	27.40	8.17	35.57	54.00	-18.43	AVG	

REMARKS:

- (1) Measurement Value = Reading Level + Correct Factor.
- (2) Margin Level = Measurement Value - Limit Value.

Test Mode	UNII-2C_TX AC(VHT20) Mode 5700 MHz	Polarization	Vertical
-----------	------------------------------------	--------------	----------

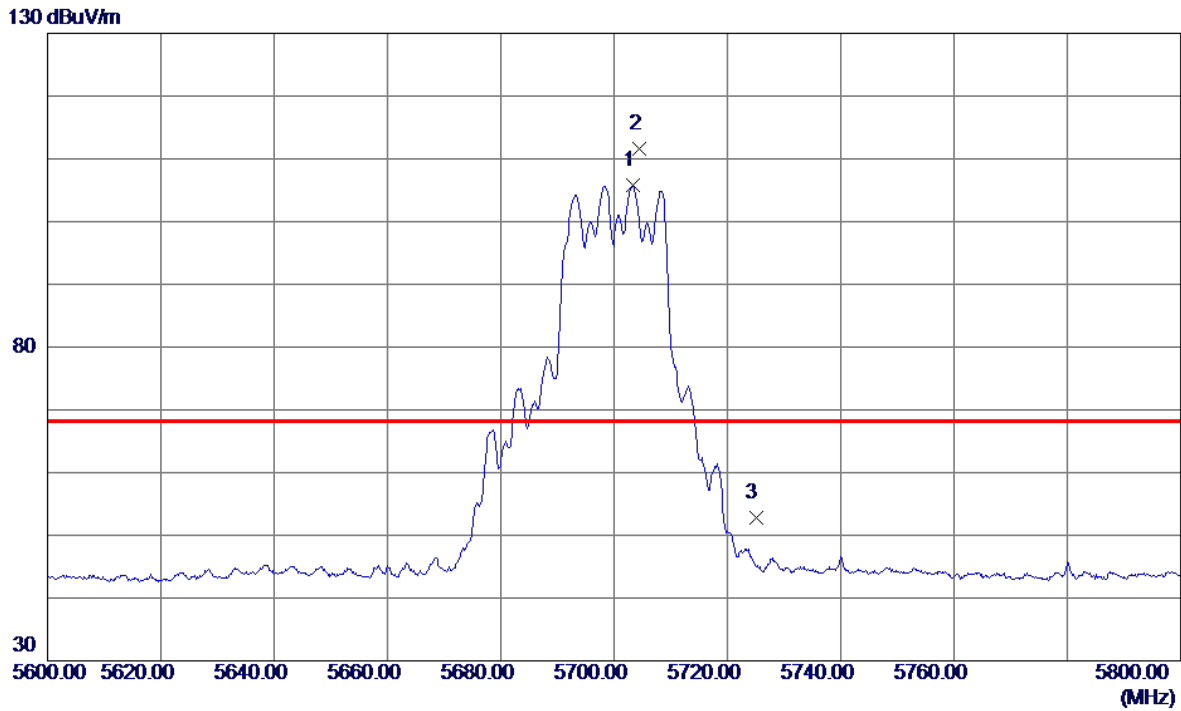

No.	Freq. MHz	Reading Level dBuV/m	Correct Factor dB	Measure ment dBuV/m	Limit dBuV/m	Margin dB	Detector	Comment
1	5703.4000	92.79	12.93	105.72	999.00	-893.28	AVG	No Limit
2 *	5704.4000	98.60	12.93	111.53	68.20	43.33	Peak	No Limit
3	5725.0000	39.83	13.00	52.83	68.20	-15.37	Peak	

REMARKS:

- (1) Measurement Value = Reading Level + Correct Factor.
- (2) Margin Level = Measurement Value - Limit Value.

Test Mode	UNII-2C_TX AC(VHT20) Mode 5700 MHz	Polarization	Horizontal
-----------	------------------------------------	--------------	------------

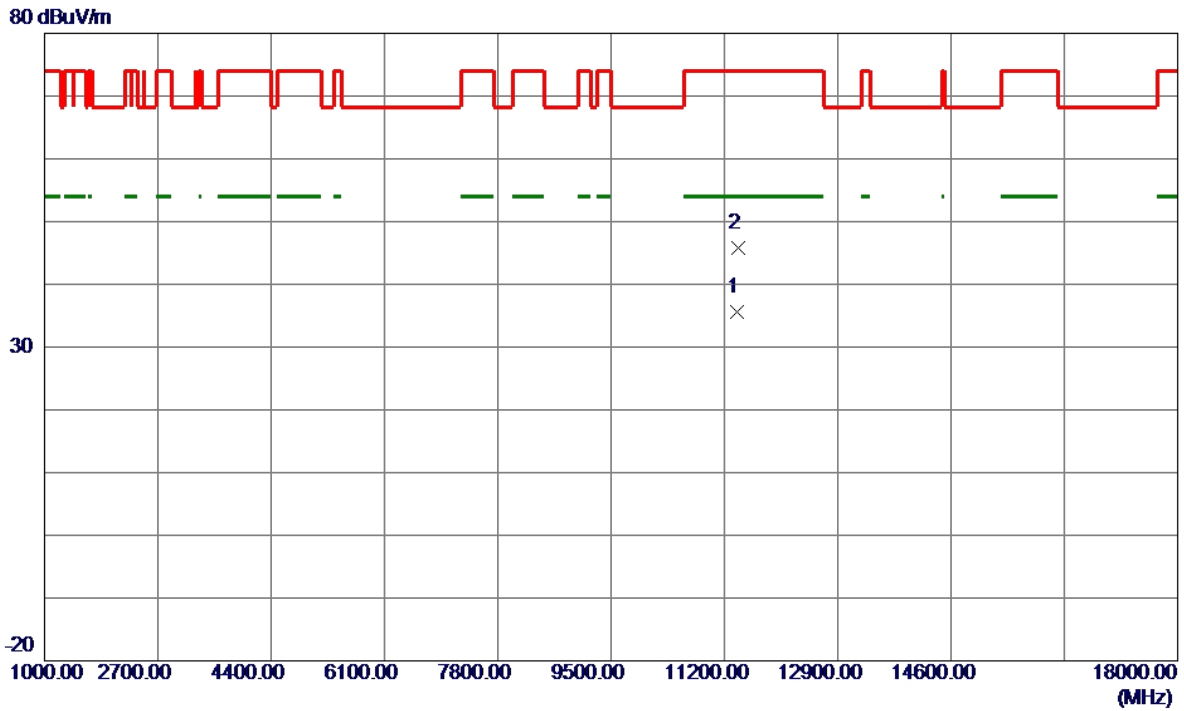

No.	Freq. MHz	Reading Level dBuV/m	Correct Factor dB	Measure ment dBuV/m	Limit dBuV/m	Margin dB	Detector	Comment
1 *	11396.7000	27.25	8.38	35.63	54.00	-18.37	AVG	
2	11408.9250	37.45	8.39	45.84	74.00	-28.16	Peak	

REMARKS:

- (1) Measurement Value = Reading Level + Correct Factor.
- (2) Margin Level = Measurement Value - Limit Value.

Test Mode	UNII-2C_TX AC(VHT40) Mode 5510 MHz	Polarization	Vertical
-----------	------------------------------------	--------------	----------

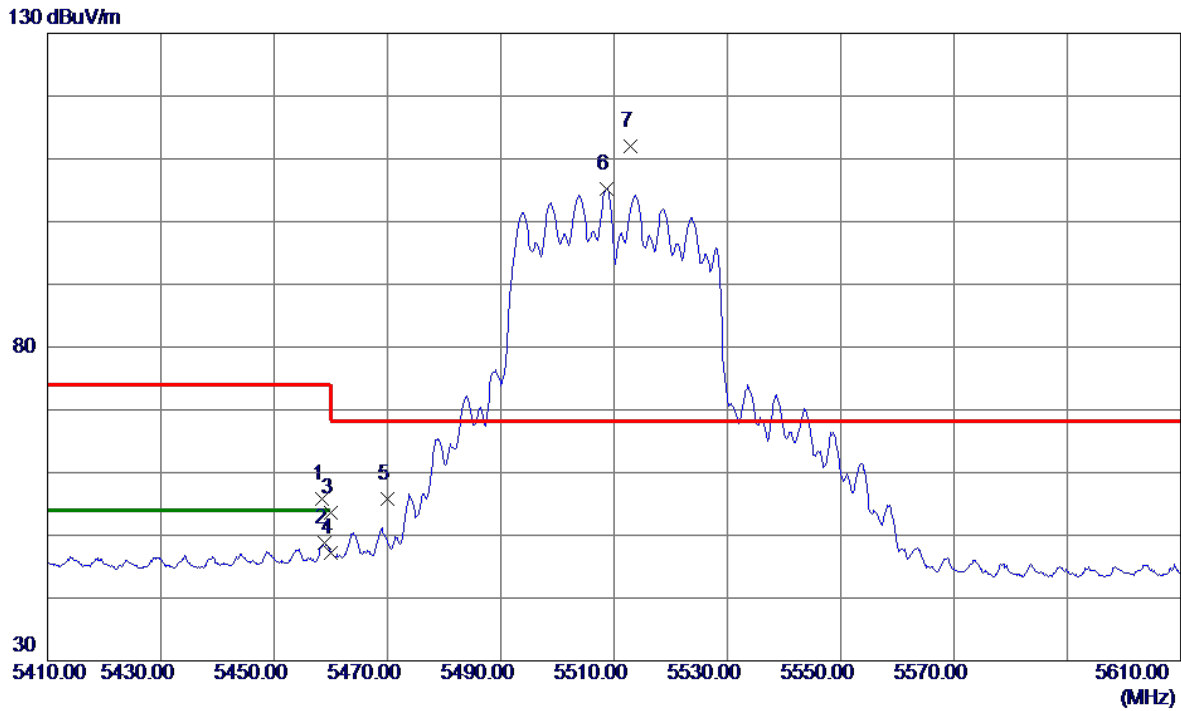

No.	Freq. MHz	Reading Level dBuV/m	Correct Factor dB	Measure ment dBuV/m	Limit dBuV/m	Margin dB	Detector	Comment
1	5458.4000	43.69	12.19	55.88	74.00	-18.12	Peak	
2	5458.8000	36.61	12.19	48.80	54.00	-5.20	AVG	
3	5460.0000	41.41	12.19	53.60	74.00	-20.40	Peak	
4	5460.0000	35.06	12.19	47.25	54.00	-6.75	AVG	
5	5470.0000	43.68	12.21	55.89	68.20	-12.31	Peak	
6	5508.6000	92.93	12.30	105.23	999.00	-893.77	AVG	No Limit
7 *	5512.9000	99.73	12.32	112.05	68.20	43.85	Peak	No Limit

REMARKS:

- (1) Measurement Value = Reading Level + Correct Factor.
- (2) Margin Level = Measurement Value - Limit Value.

Test Mode	UNII-2C_TX AC(VHT40) Mode 5510 MHz	Polarization	Horizontal
-----------	------------------------------------	--------------	------------

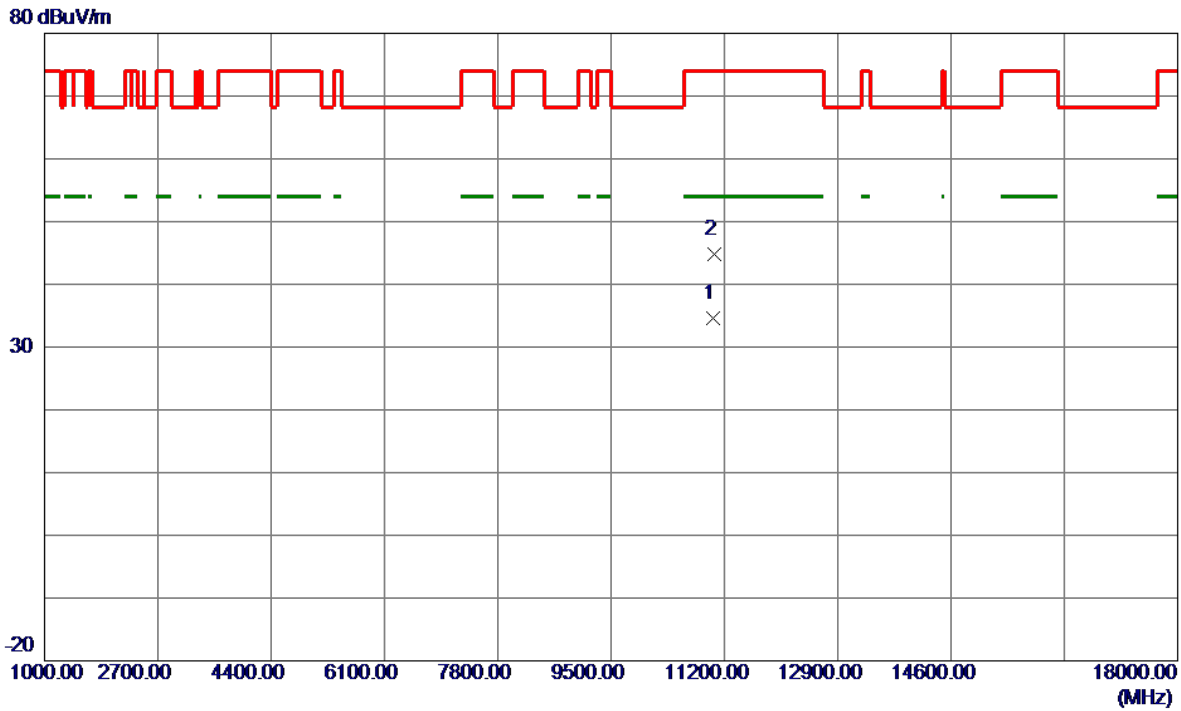

No.	Freq. MHz	Reading Level dBuV/m	Correct Factor dB	Measure ment dBuV/m	Limit dBuV/m	Margin dB	Detector	Comment
1 *	11033.7250	26.56	8.06	34.62	54.00	-19.38	AVG	
2	11044.3000	36.64	8.07	44.71	74.00	-29.29	Peak	

REMARKS:

- (1) Measurement Value = Reading Level + Correct Factor.
- (2) Margin Level = Measurement Value - Limit Value.

Test Mode	UNII-2C_TX AC(VHT40) Mode 5550 MHz	Polarization	Horizontal
-----------	------------------------------------	--------------	------------

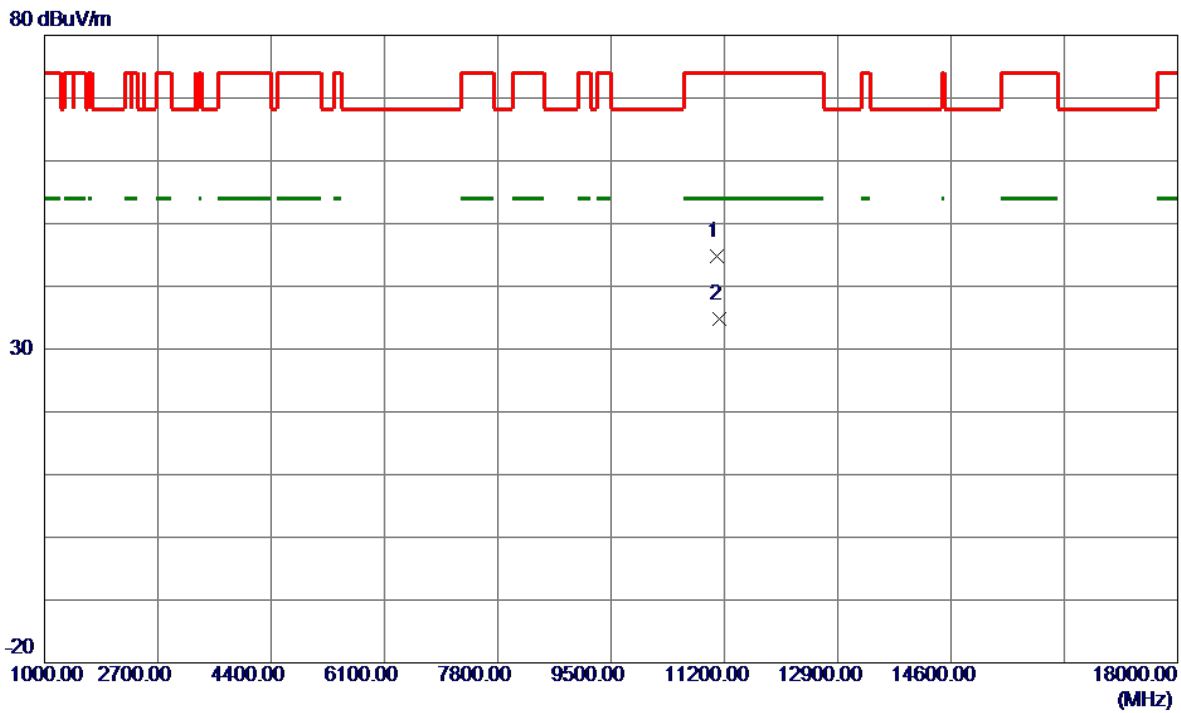

No.	Freq. MHz	Reading Level dBuV/m	Correct Factor dB	Measure ment dBuV/m	Limit dBuV/m	Margin dB	Detector	Comment
1	11089.6250	36.61	8.11	44.72	74.00	-29.28	Peak	
2 *	11115.1750	26.70	8.13	34.83	54.00	-19.17	AVG	

REMARKS:

- (1) Measurement Value = Reading Level + Correct Factor.
- (2) Margin Level = Measurement Value - Limit Value.

Test Mode	UNII-2C_TX AC(VHT40) Mode 5670 MHz	Polarization	Vertical
-----------	------------------------------------	--------------	----------

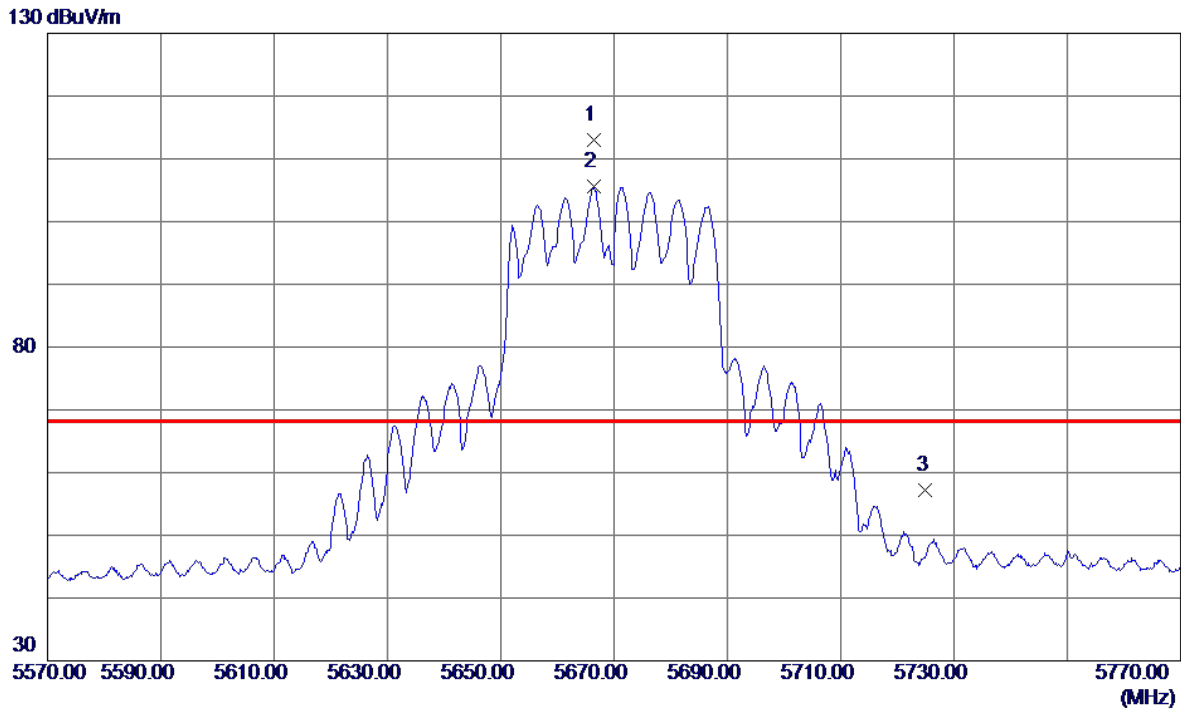

No.	Freq. MHz	Reading Level dBuV/m	Correct Factor dB	Measure ment dBuV/m	Limit dBuV/m	Margin dB	Detector	Comment
1 *	5666.4000	100.20	12.81	113.01	68.20	44.81	Peak	No Limit
2	5666.4000	92.75	12.81	105.56	999.00	-893.44	AVG	No Limit
3	5725.0000	44.24	13.00	57.24	68.20	-10.96	Peak	

REMARKS:

- (1) Measurement Value = Reading Level + Correct Factor.
- (2) Margin Level = Measurement Value - Limit Value.

Test Mode	UNII-2C_TX AC(VHT40) Mode 5670 MHz	Polarization	Horizontal
-----------	------------------------------------	--------------	------------

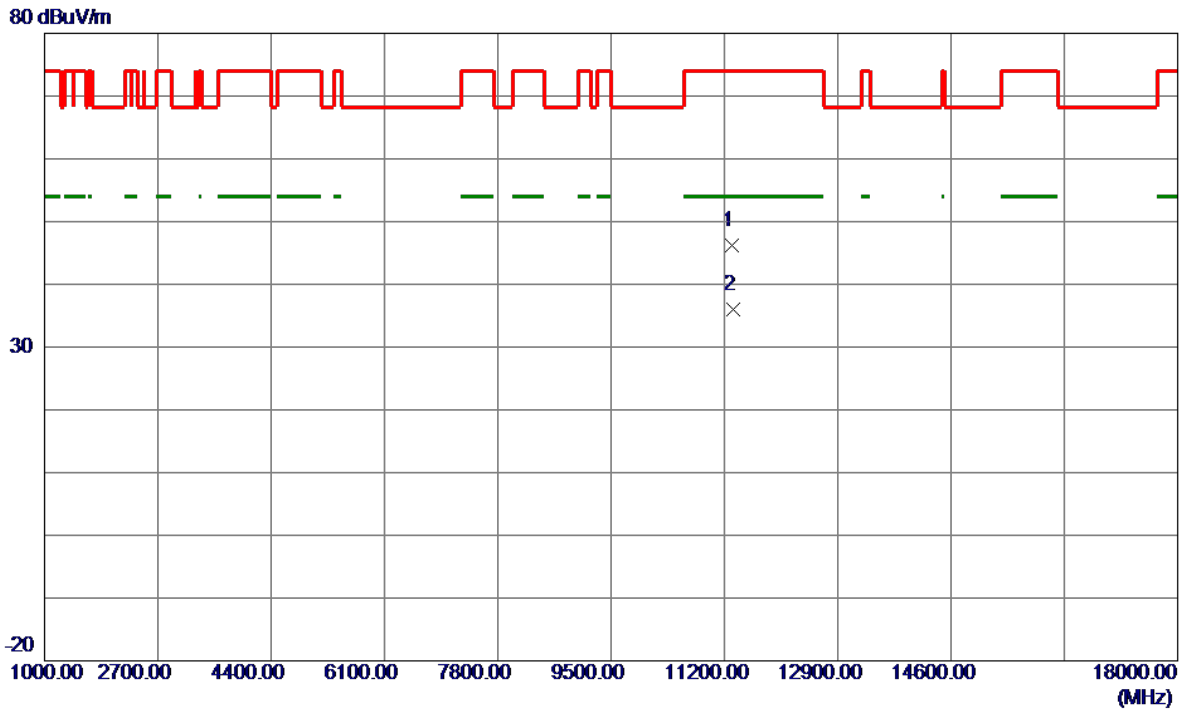

No.	Freq. MHz	Reading Level dBuV/m	Correct Factor dB	Measure ment dBuV/m	Limit dBuV/m	Margin dB	Detector	Comment
1	11316.5000	37.86	8.31	46.17	74.00	-27.83	Peak	
2 *	11338.6750	27.60	8.32	35.92	54.00	-18.08	AVG	

REMARKS:

- (1) Measurement Value = Reading Level + Correct Factor.
- (2) Margin Level = Measurement Value - Limit Value.

Test Mode	UNII-2C_TX AC(VHT80) Mode 5530 MHz	Polarization	Vertical
-----------	------------------------------------	--------------	----------

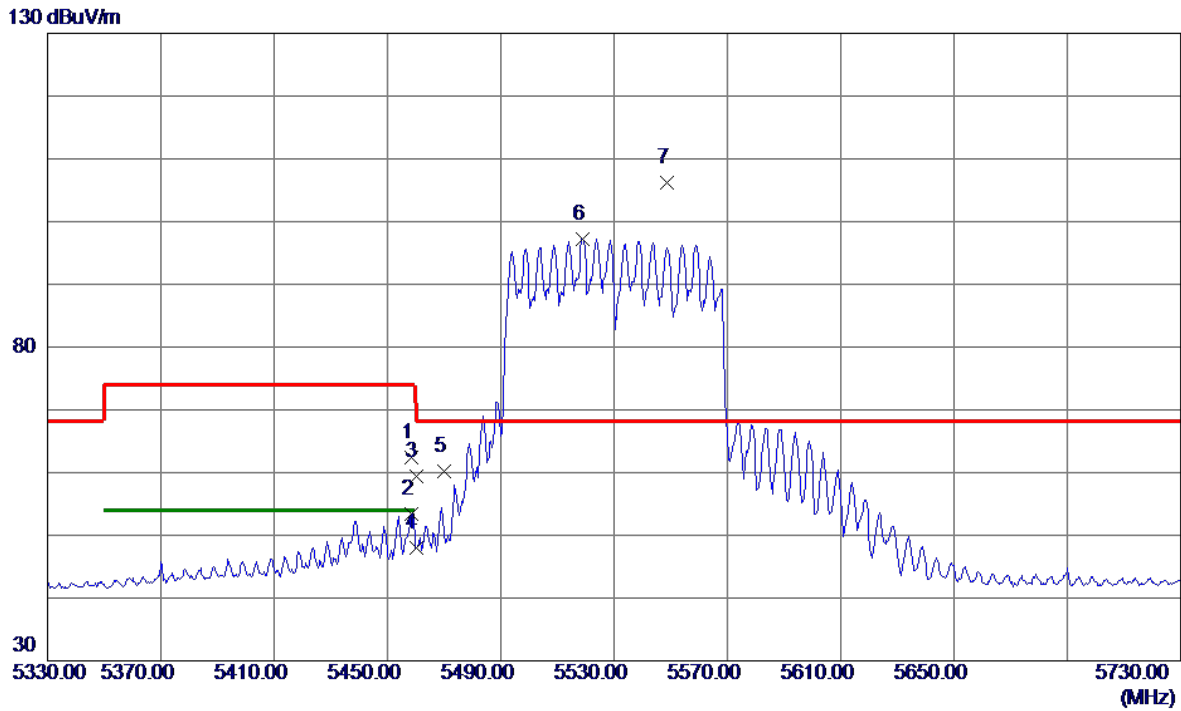

No.	Freq. MHz	Reading Level dBuV/m	Correct Factor dB	Measure ment dBuV/m	Limit dBuV/m	Margin dB	Detector	Comment
1	5458.6000	50.16	12.19	62.35	74.00	-11.65	Peak	
2	5458.6000	41.23	12.19	53.42	54.00	-0.58	AVG	
3	5460.0000	47.22	12.19	59.41	74.00	-14.59	Peak	
4	5460.0000	35.80	12.19	47.99	54.00	-6.01	AVG	
5	5470.0000	48.01	12.21	60.22	68.20	-7.98	Peak	
6	5518.8000	84.90	12.34	97.24	999.00	-901.76	AVG	No Limit
7 *	5548.8000	93.74	12.43	106.17	68.20	37.97	Peak	No Limit

REMARKS:

- (1) Measurement Value = Reading Level + Correct Factor.
- (2) Margin Level = Measurement Value - Limit Value.

Test Mode	UNII-2C_TX AC(VHT80) Mode 5530 MHz	Polarization	Horizontal
-----------	------------------------------------	--------------	------------

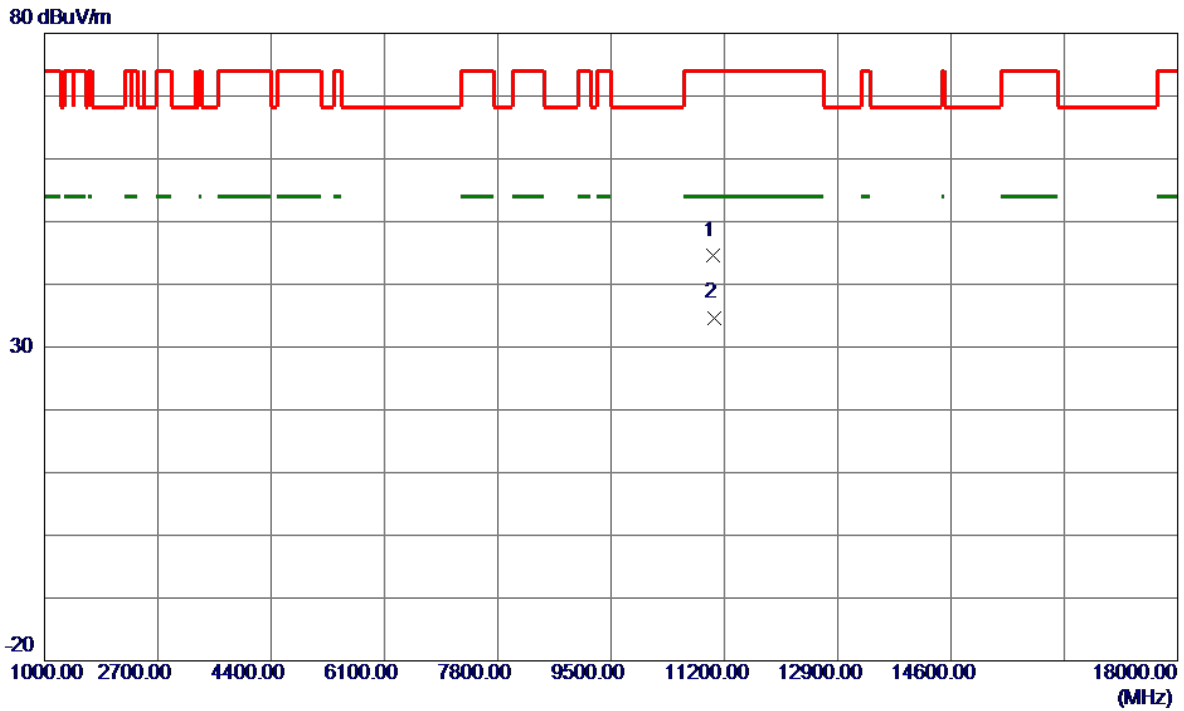

No.	Freq. MHz	Reading Level dBuV/m	Correct Factor dB	Measure ment dBuV/m	Limit dBuV/m	Margin dB	Detector	Comment
1	11033.7000	36.52	8.06	44.58	74.00	-29.42	Peak	
2 *	11049.7000	26.63	8.07	34.70	54.00	-19.30	AVG	

REMARKS:

- (1) Measurement Value = Reading Level + Correct Factor.
- (2) Margin Level = Measurement Value - Limit Value.

Test Mode	UNII-2C_TX AX(HE20) Mode 5500 MHz	Polarization	Vertical
-----------	-----------------------------------	--------------	----------

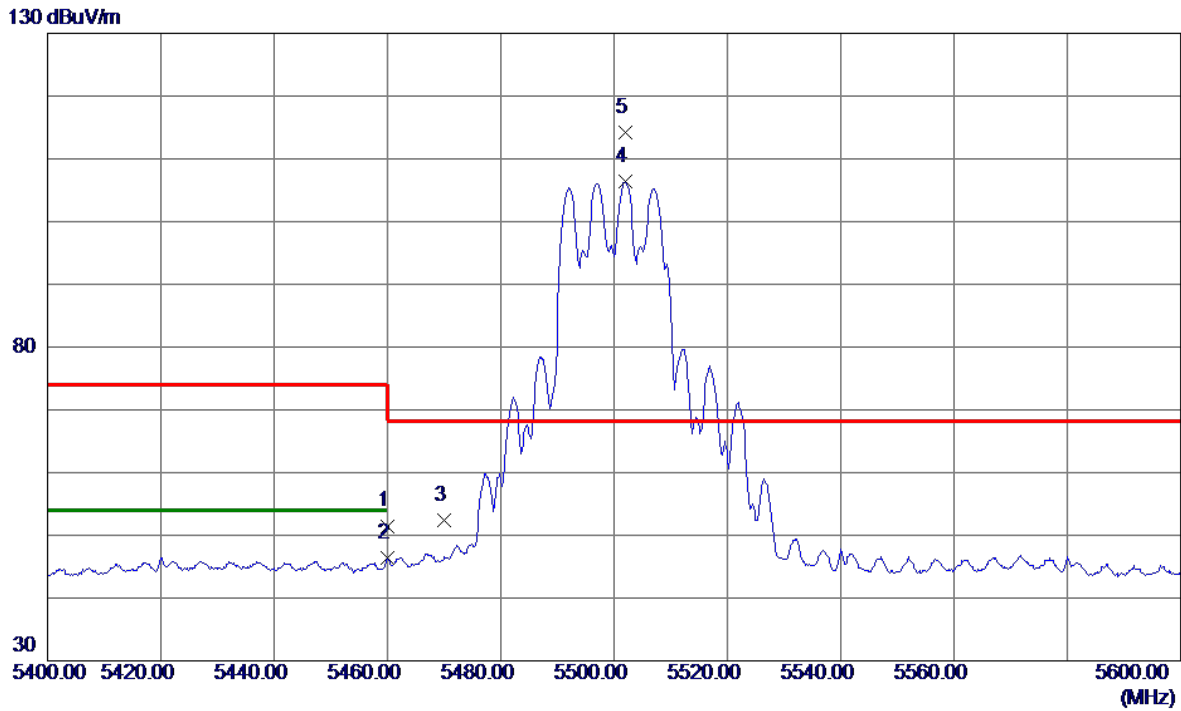

No.	Freq. MHz	Reading Level dBuV/m	Correct Factor dB	Measure ment dBuV/m	Limit dBuV/m	Margin dB	Detector	Comment
1	5460.0000	39.31	12.19	51.50	74.00	-22.50	Peak	
2	5460.0000	34.22	12.19	46.41	54.00	-7.59	AVG	
3	5470.0000	40.26	12.21	52.47	68.20	-15.73	Peak	
4	5501.9000	94.18	12.28	106.46	999.00	-892.54	AVG	No Limit
5 *	5502.0000	102.02	12.28	114.30	68.20	46.10	Peak	No Limit

REMARKS:

- (1) Measurement Value = Reading Level + Correct Factor.
- (2) Margin Level = Measurement Value - Limit Value.

Test Mode	UNII-2C_TX AX(HE20) Mode 5500 MHz	Polarization	Horizontal
-----------	-----------------------------------	--------------	------------

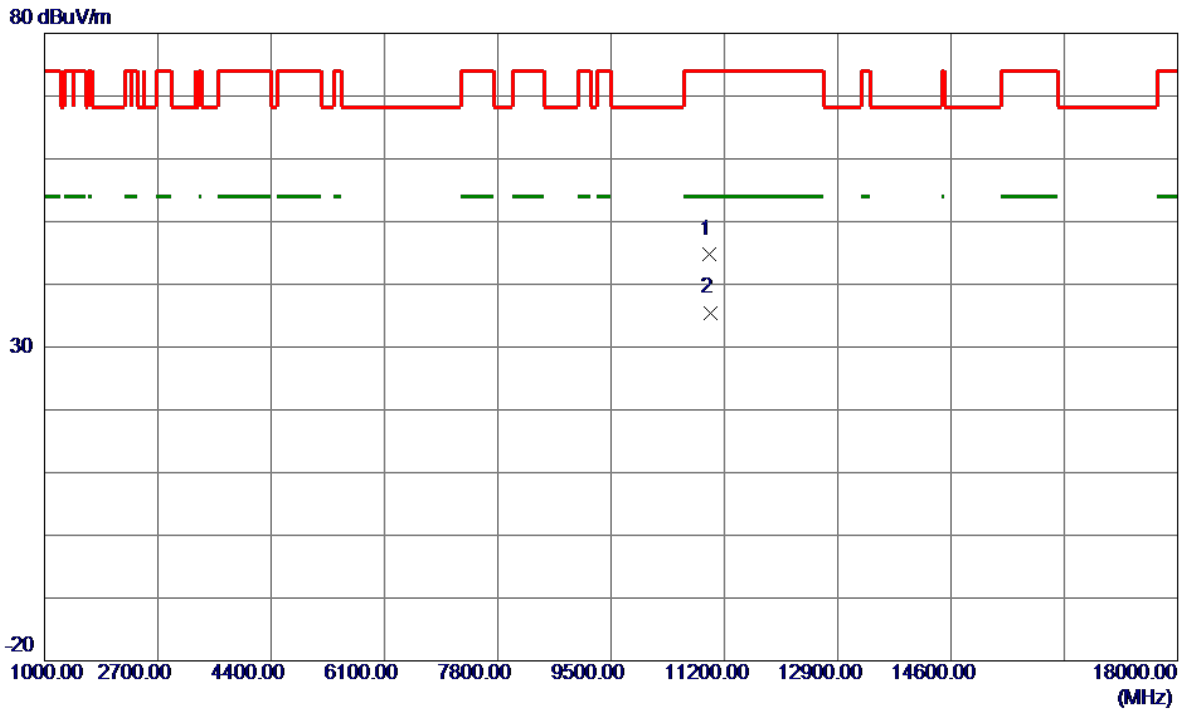

No.	Freq. MHz	Reading Level dBuV/m	Correct Factor dB	Measure ment dBuV/m	Limit dBuV/m	Margin dB	Detector	Comment
1	10980.1500	36.85	8.02	44.87	74.00	-29.13	Peak	
2 *	11001.1500	27.47	8.03	35.50	54.00	-18.50	AVG	

REMARKS:

- (1) Measurement Value = Reading Level + Correct Factor.
- (2) Margin Level = Measurement Value - Limit Value.

Test Mode	UNII-2C_TX AX(HE20) Mode 5580 MHz	Polarization	Horizontal
-----------	-----------------------------------	--------------	------------

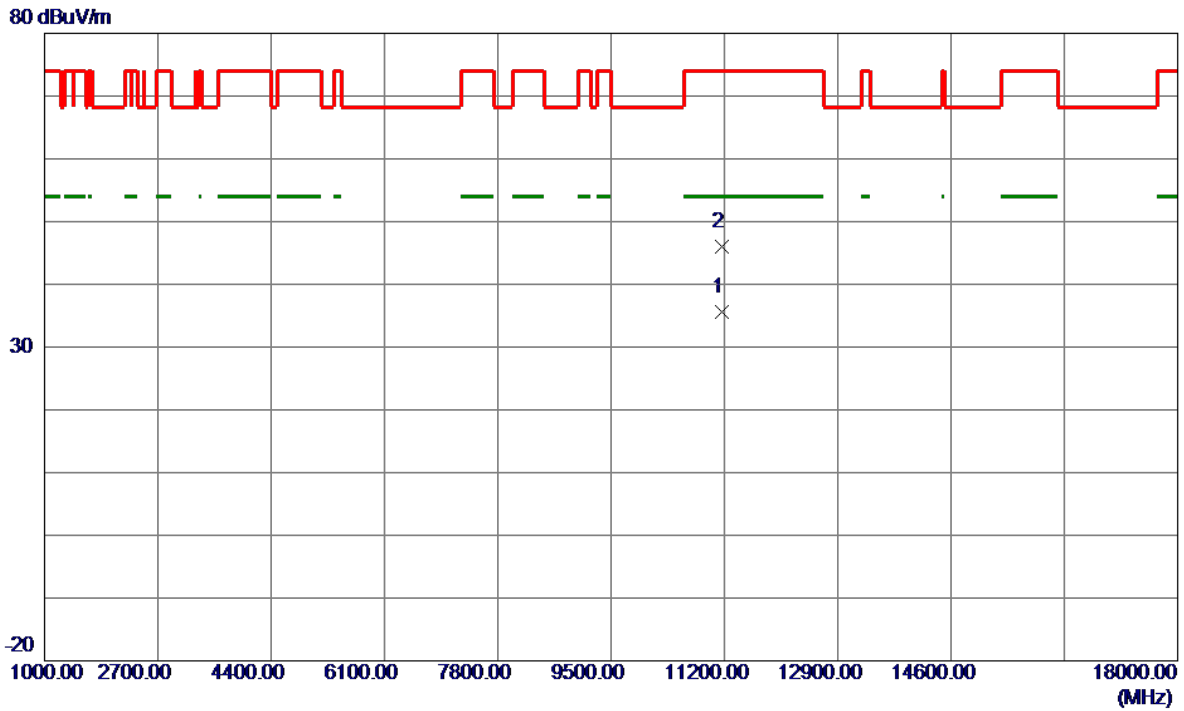

No.	Freq. MHz	Reading Level dBuV/m	Correct Factor dB	Measure ment dBuV/m	Limit dBuV/m	Margin dB	Detector	Comment
1 *	11157.9250	27.43	8.17	35.60	54.00	-18.40	AVG	
2	11162.6750	37.81	8.17	45.98	74.00	-28.02	Peak	

REMARKS:

- (1) Measurement Value = Reading Level + Correct Factor.
- (2) Margin Level = Measurement Value - Limit Value.

Test Mode	UNII-2C_TX AX(HE20) Mode 5700 MHz	Polarization	Vertical
-----------	-----------------------------------	--------------	----------

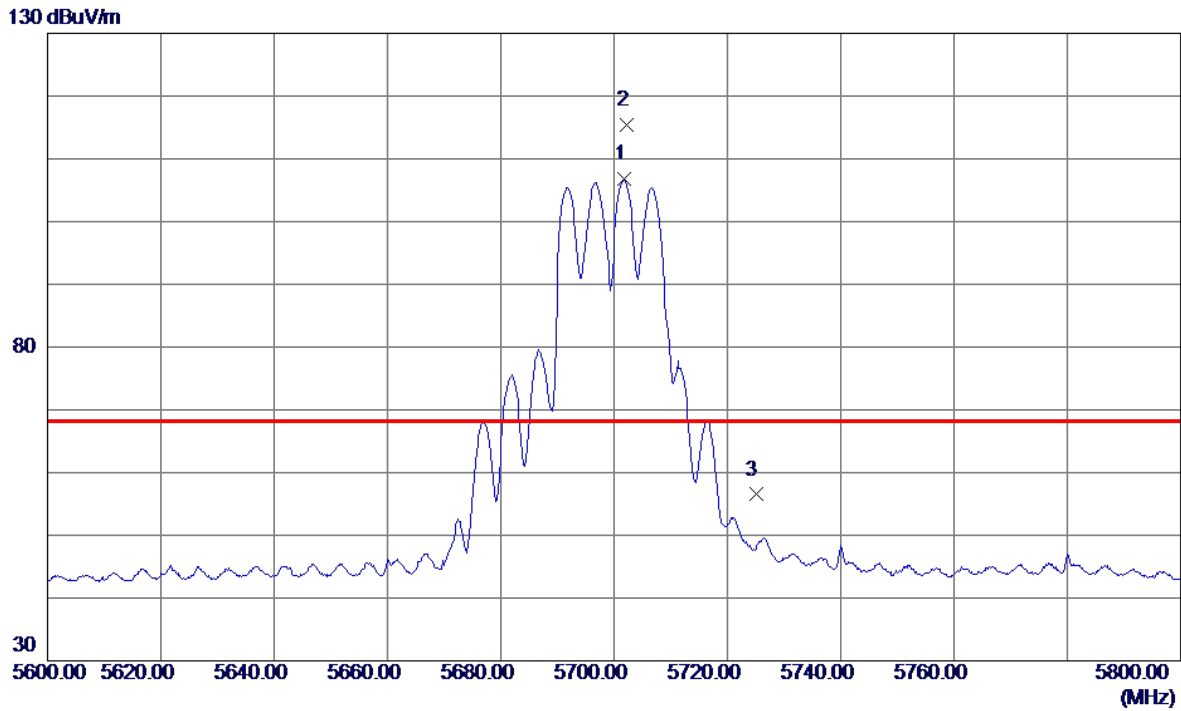

No.	Freq. MHz	Reading Level dBuV/m	Correct Factor dB	Measure ment dBuV/m	Limit dBuV/m	Margin dB	Detector	Comment
1	5701.7000	93.84	12.92	106.76	999.00	-892.24	AVG	No Limit
2 *	5702.2000	102.57	12.92	115.49	68.20	47.29	Peak	No Limit
3	5725.0000	43.50	13.00	56.50	68.20	-11.70	Peak	

REMARKS:

- (1) Measurement Value = Reading Level + Correct Factor.
- (2) Margin Level = Measurement Value - Limit Value.

Test Mode	UNII-2C_TX AX(HE20) Mode 5700 MHz	Polarization	Horizontal
-----------	-----------------------------------	--------------	------------

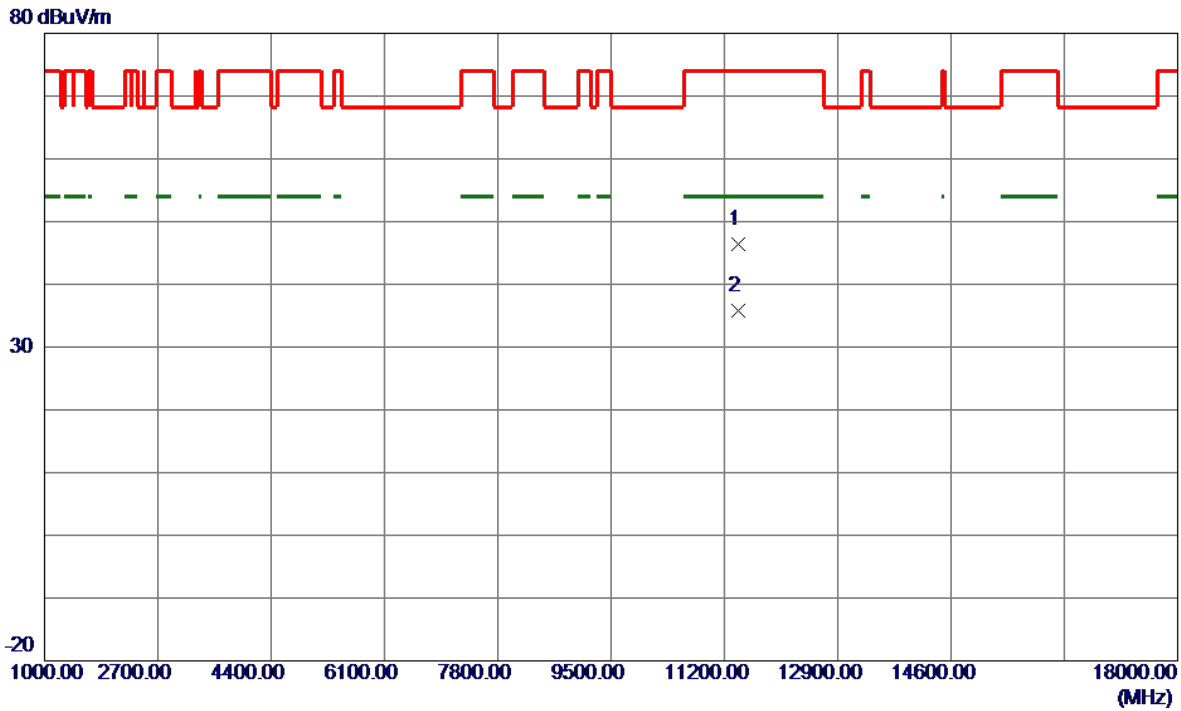

No.	Freq. MHz	Reading Level dBuV/m	Correct Factor dB	Measure ment dBuV/m	Limit dBuV/m	Margin dB	Detector	Comment
1	11401.4000	38.04	8.38	46.42	74.00	-27.58	Peak	
2 *	11402.2250	27.43	8.38	35.81	54.00	-18.19	AVG	

REMARKS:

- (1) Measurement Value = Reading Level + Correct Factor.
- (2) Margin Level = Measurement Value - Limit Value.

Test Mode	UNII-2C_TX AX(HE40) Mode 5510 MHz	Polarization	Vertical
-----------	-----------------------------------	--------------	----------

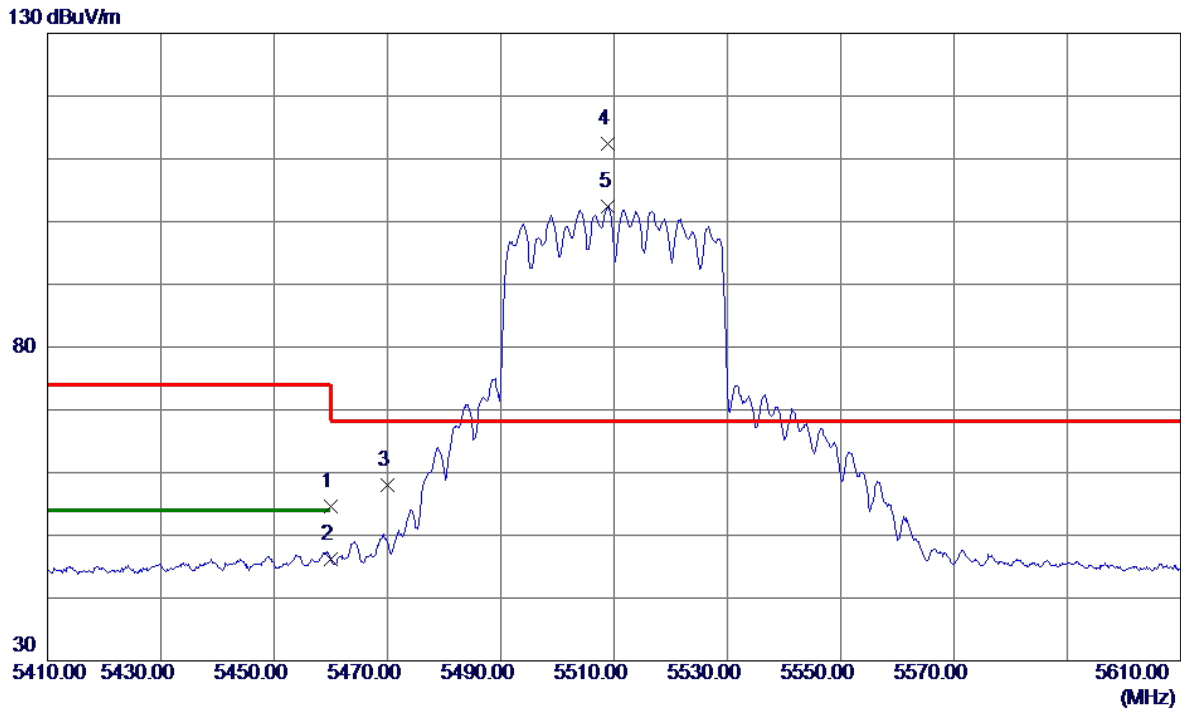

No.	Freq. MHz	Reading Level dBuV/m	Correct Factor dB	Measure ment dBuV/m	Limit dBuV/m	Margin dB	Detector	Comment
1	5460.0000	42.34	12.19	54.53	74.00	-19.47	Peak	
2	5460.0000	34.01	12.19	46.20	54.00	-7.80	AVG	
3	5470.0000	45.84	12.21	58.05	68.20	-10.15	Peak	
4 *	5508.8000	100.12	12.30	112.42	68.20	44.22	Peak	No Limit
5	5509.0000	90.11	12.30	102.41	999.00	-896.59	AVG	No Limit

REMARKS:

- (1) Measurement Value = Reading Level + Correct Factor.
- (2) Margin Level = Measurement Value - Limit Value.

Test Mode	UNII-2C_TX AX(HE40) Mode 5510 MHz	Polarization	Horizontal
-----------	-----------------------------------	--------------	------------

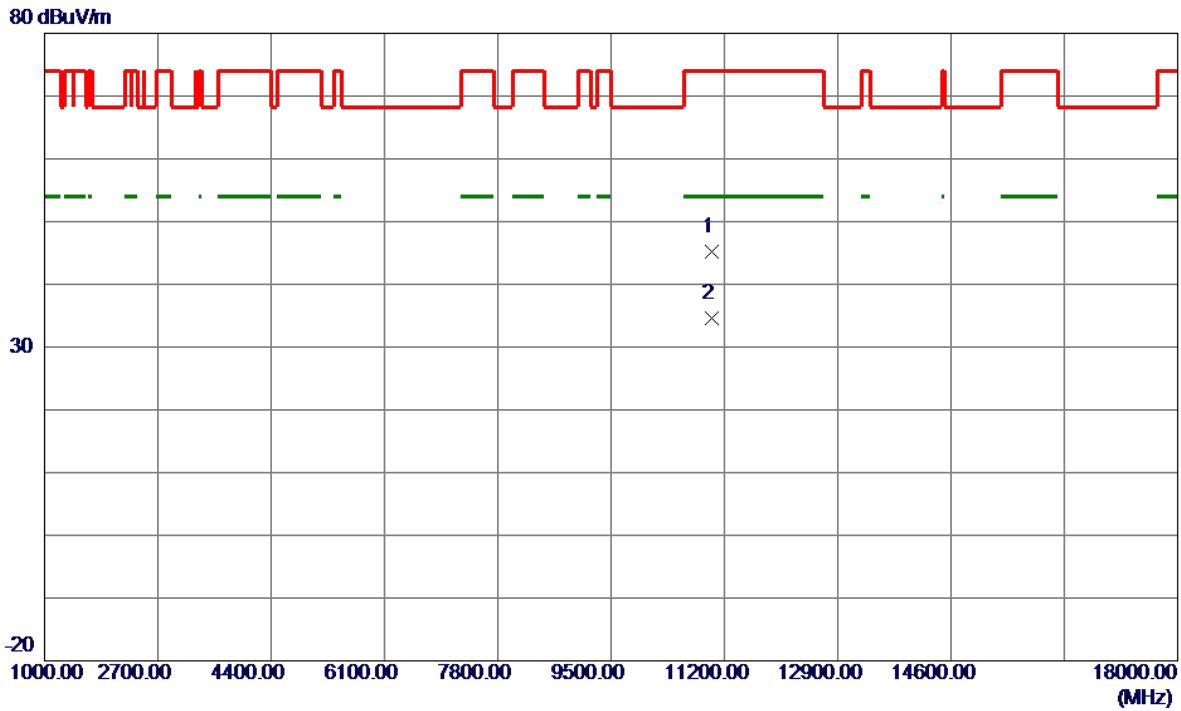

No.	Freq. MHz	Reading Level dBuV/m	Correct Factor dB	Measure ment dBuV/m	Limit dBuV/m	Margin dB	Detector	Comment
1	11018.1500	37.22	8.05	45.27	74.00	-28.73	Peak	
2 *	11019.0000	26.56	8.05	34.61	54.00	-19.39	AVG	

REMARKS:

- (1) Measurement Value = Reading Level + Correct Factor.
- (2) Margin Level = Measurement Value - Limit Value.

Test Mode	UNII-2C_TX AX(HE40) Mode 5550 MHz	Polarization	Horizontal
-----------	-----------------------------------	--------------	------------

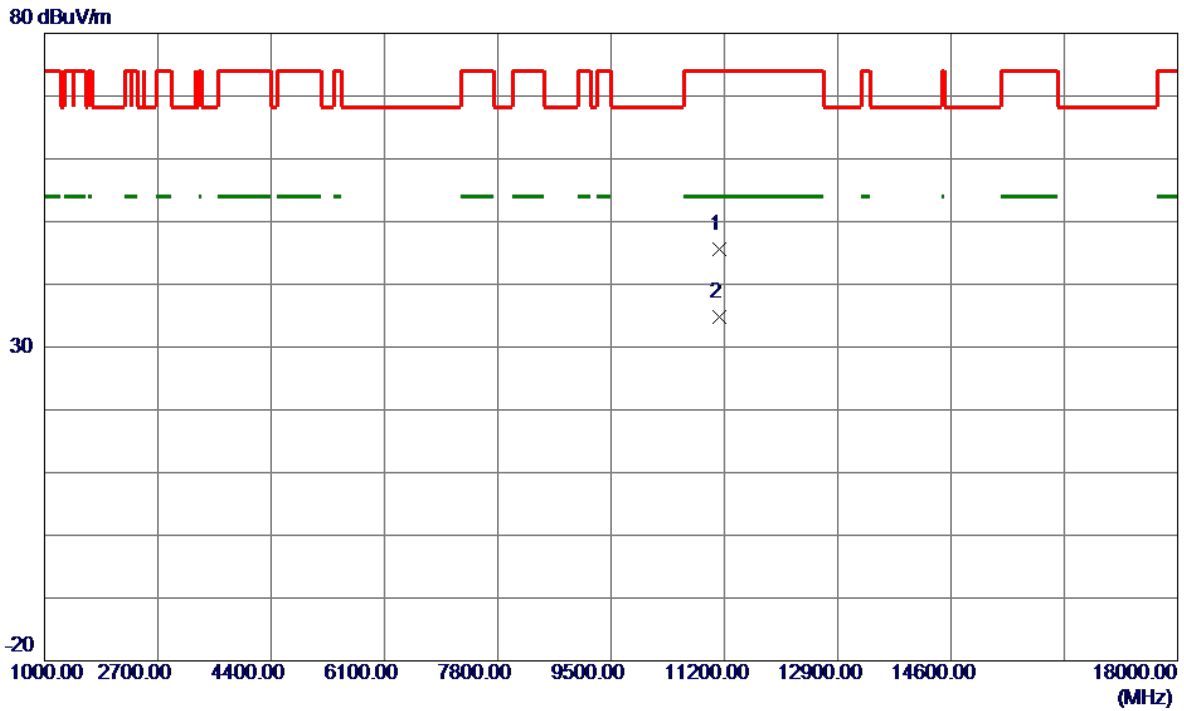

No.	Freq. MHz	Reading Level dBuV/m	Correct Factor dB	Measure ment dBuV/m	Limit dBuV/m	Margin dB	Detector	Comment
1	11116.0500	37.48	8.13	45.61	74.00	-28.39	Peak	
2 *	11124.7500	26.71	8.14	34.85	54.00	-19.15	AVG	

REMARKS:

- (1) Measurement Value = Reading Level + Correct Factor.
- (2) Margin Level = Measurement Value - Limit Value.

Test Mode	UNII-2C_TX AX(HE40) Mode 5670 MHz	Polarization	Vertical
-----------	-----------------------------------	--------------	----------

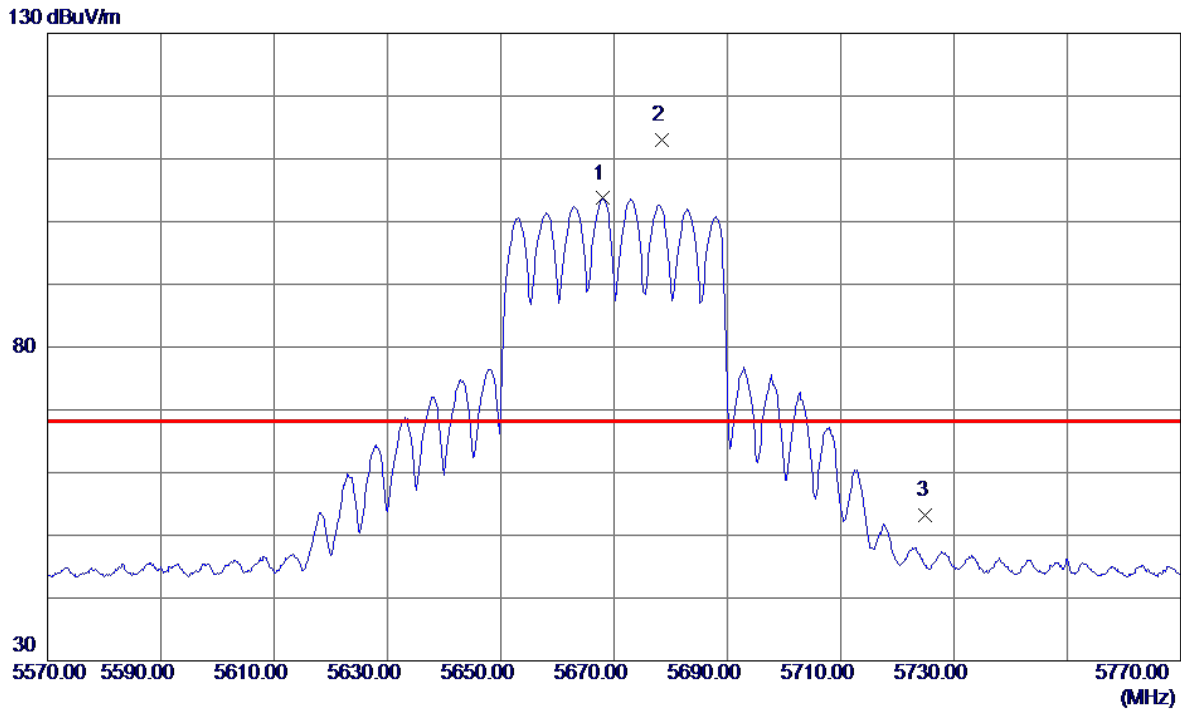

No.	Freq. MHz	Reading Level dBuV/m	Correct Factor dB	Measure ment dBuV/m	Limit dBuV/m	Margin dB	Detector	Comment
1	5668.1000	90.89	12.81	103.70	999.00	-895.30	AVG	No Limit
2 *	5678.5000	100.20	12.85	113.05	68.20	44.85	Peak	No Limit
3	5725.0000	40.19	13.00	53.19	68.20	-15.01	Peak	

REMARKS:

- (1) Measurement Value = Reading Level + Correct Factor.
- (2) Margin Level = Measurement Value - Limit Value.

Test Mode	UNII-2C_TX AX(HE40) Mode 5670 MHz	Polarization	Horizontal
-----------	-----------------------------------	--------------	------------

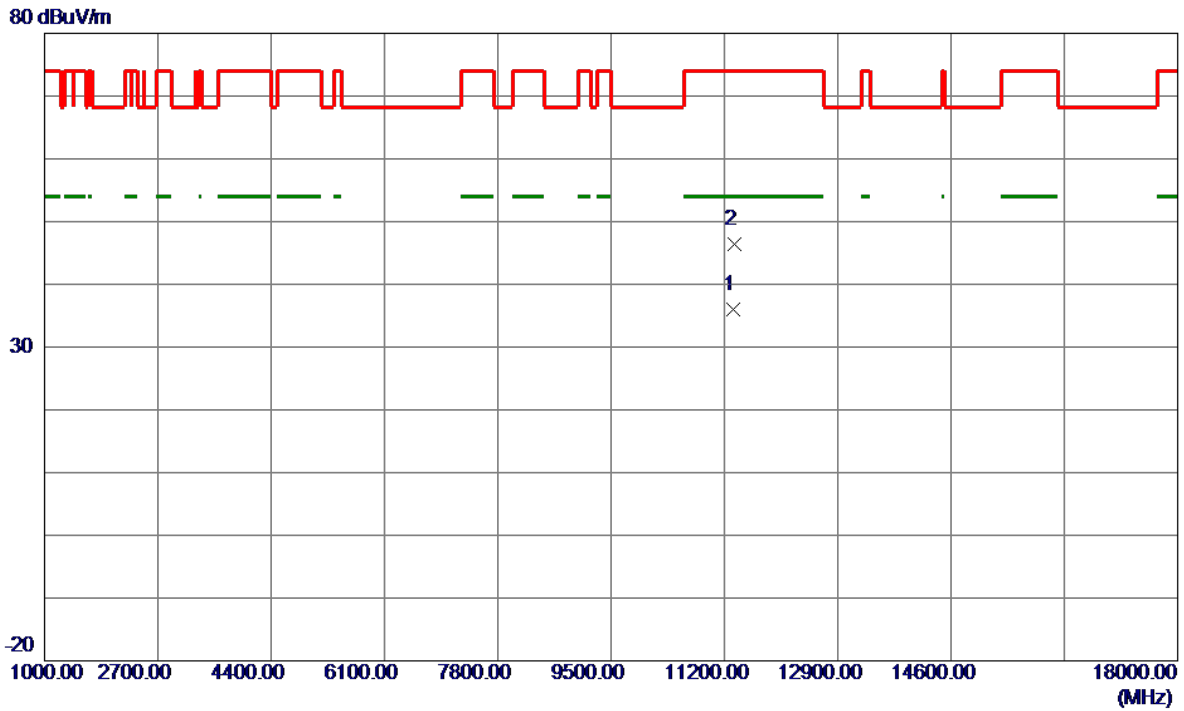

No.	Freq. MHz	Reading Level dBuV/m	Correct Factor dB	Measure ment dBuV/m	Limit dBuV/m	Margin dB	Detector	Comment
1 *	11333.6250	27.67	8.32	35.99	54.00	-18.01	AVG	
2	11342.7000	38.05	8.33	46.38	74.00	-27.62	Peak	

REMARKS:

- (1) Measurement Value = Reading Level + Correct Factor.
- (2) Margin Level = Measurement Value - Limit Value.

Test Mode	UNII-2C_TX AX(HE80) Mode 5530 MHz	Polarization	Vertical
-----------	-----------------------------------	--------------	----------

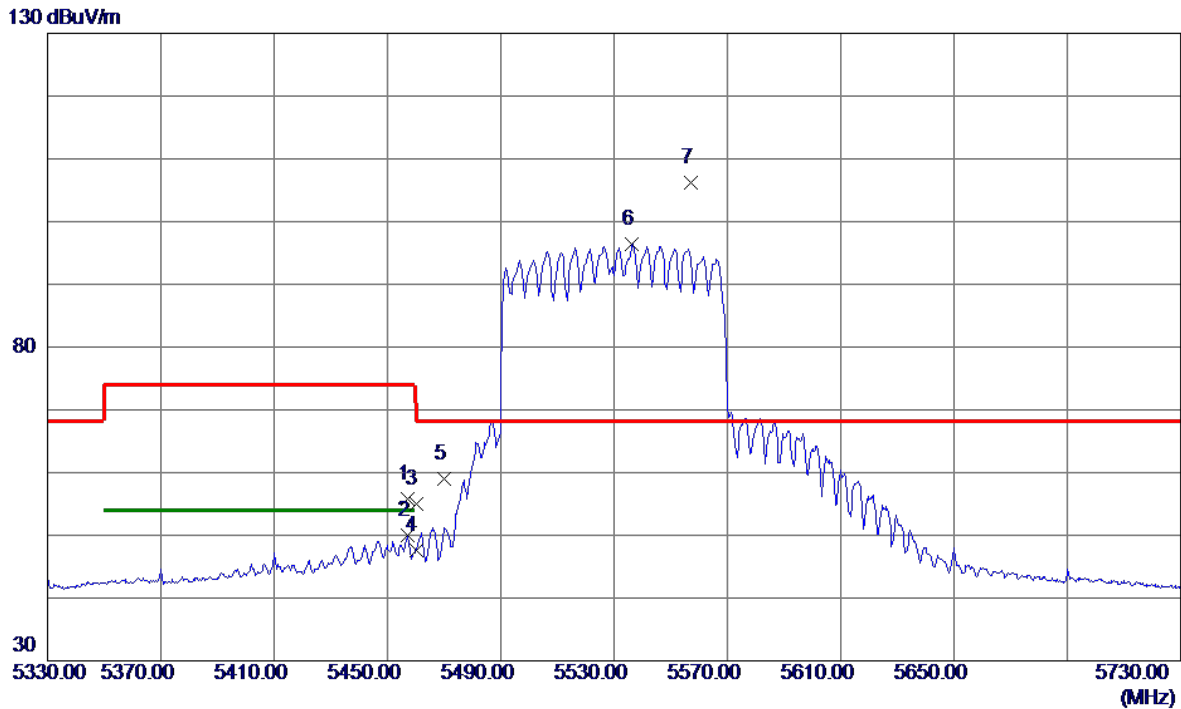

No.	Freq. MHz	Reading Level dBuV/m	Correct Factor dB	Measure ment dBuV/m	Limit dBuV/m	Margin dB	Detector	Comment
1	5457.0000	43.63	12.18	55.81	74.00	-18.19	Peak	
2	5457.0000	37.77	12.18	49.95	54.00	-4.05	AVG	
3	5460.0000	42.80	12.19	54.99	74.00	-19.01	Peak	
4	5460.0000	35.37	12.19	47.56	54.00	-6.44	AVG	
5	5470.0000	46.84	12.21	59.05	68.20	-9.15	Peak	
6	5536.4000	83.97	12.39	96.36	999.00	-902.64	AVG	No Limit
7 *	5557.2000	93.78	12.46	106.24	68.20	38.04	Peak	No Limit

REMARKS:

- (1) Measurement Value = Reading Level + Correct Factor.
- (2) Margin Level = Measurement Value - Limit Value.

Test Mode	UNII-2C_TX AX(HE80) Mode 5530 MHz	Polarization	Horizontal
-----------	-----------------------------------	--------------	------------

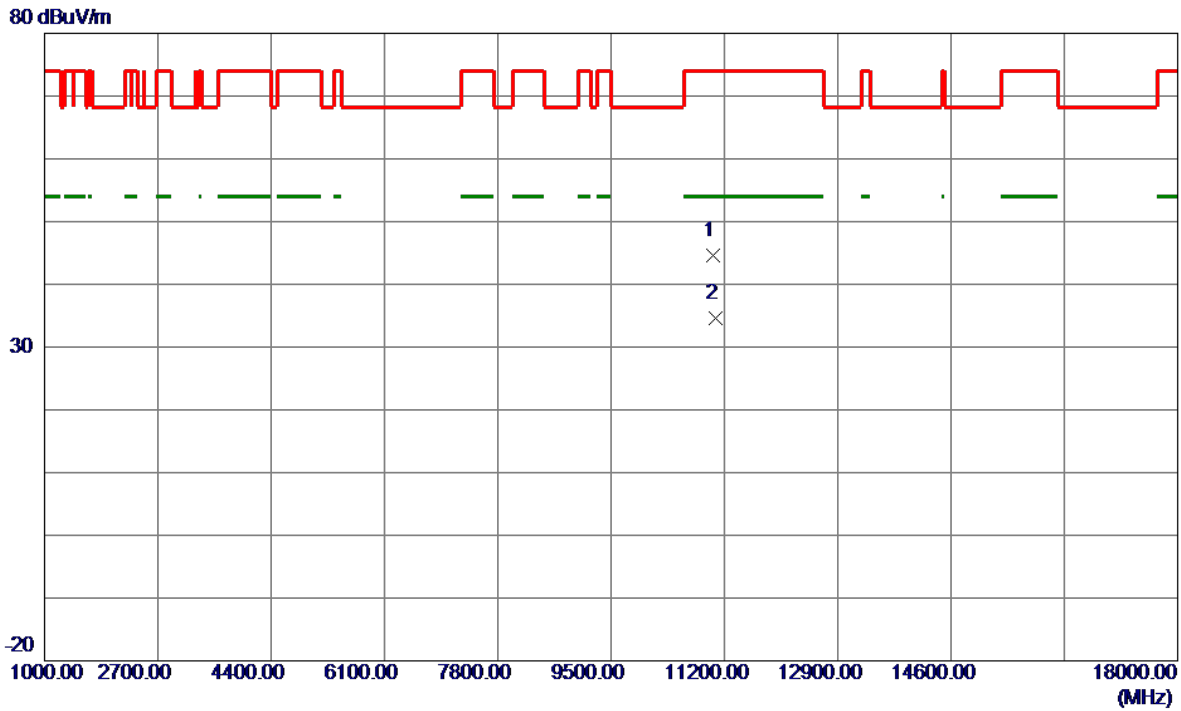

No.	Freq. MHz	Reading Level dBuV/m	Correct Factor dB	Measure ment dBuV/m	Limit dBuV/m	Margin dB	Detector	Comment
1	11025.6500	36.60	8.05	44.65	74.00	-29.35	Peak	
2 *	11058.5500	26.57	8.08	34.65	54.00	-19.35	AVG	

REMARKS:

- (1) Measurement Value = Reading Level + Correct Factor.
- (2) Margin Level = Measurement Value - Limit Value.

Test Mode	UNII-3_TX A Mode 5745 MHz	Polarization	Vertical
-----------	---------------------------	--------------	----------

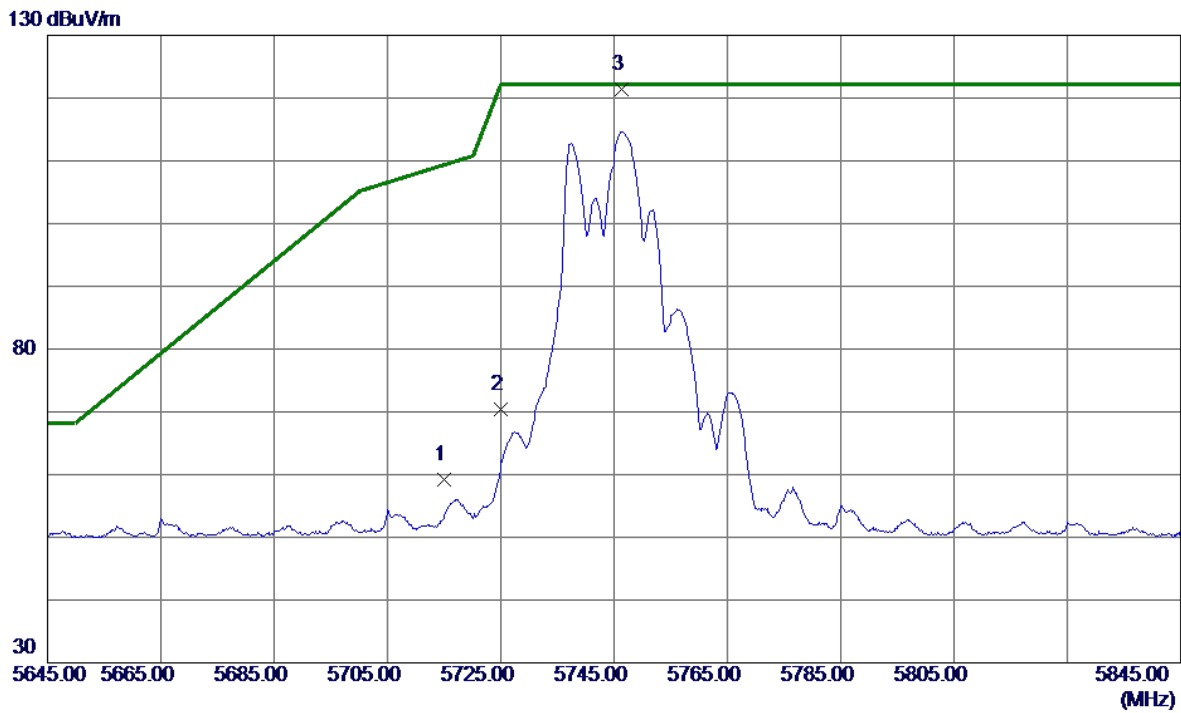

No.	Freq. MHz	Reading Level dBuV/m	Correct Factor dB	Measure ment dBuV/m	Limit dBuV/m	Margin dB	Detector	Comment
1	5715.0000	46.27	12.97	59.24	109.40	-50.16	Peak	
2	5725.0000	57.41	13.00	70.41	122.20	-51.79	Peak	
3 *	5746.4000	108.38	13.07	121.45	122.20	-0.75	Peak	No Limit

REMARKS:

- (1) Measurement Value = Reading Level + Correct Factor.
- (2) Margin Level = Measurement Value - Limit Value.

Test Mode	UNII-3_TX A Mode 5745 MHz	Polarization	Horizontal
-----------	---------------------------	--------------	------------

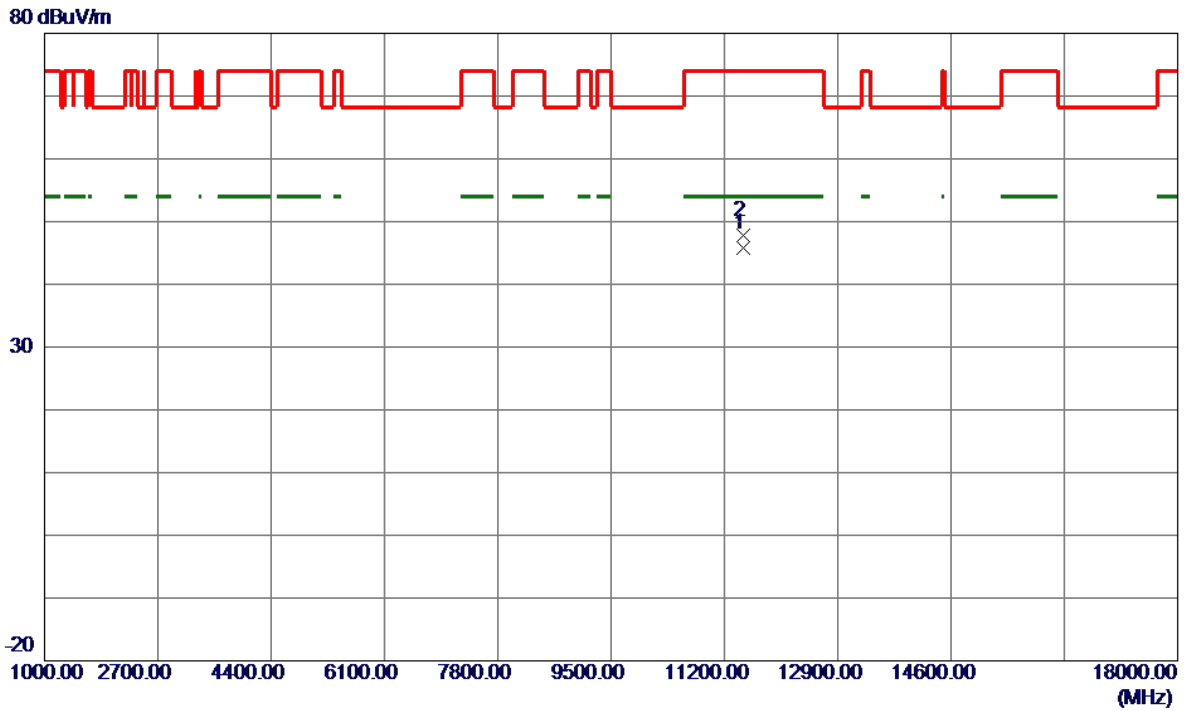

No.	Freq. MHz	Reading Level dBuV/m	Correct Factor dB	Measure ment dBuV/m	Limit dBuV/m	Margin dB	Detector	Comment
1	11486.5250	37.43	8.45	45.88	74.00	-28.12	Peak	
2 *	11486.8000	39.33	8.45	47.78	54.00	-6.22	AVG	

REMARKS:

- (1) Measurement Value = Reading Level + Correct Factor.
- (2) Margin Level = Measurement Value - Limit Value.

Test Mode	UNII-3_TX A Mode 5785 MHz	Polarization	Horizontal
-----------	---------------------------	--------------	------------

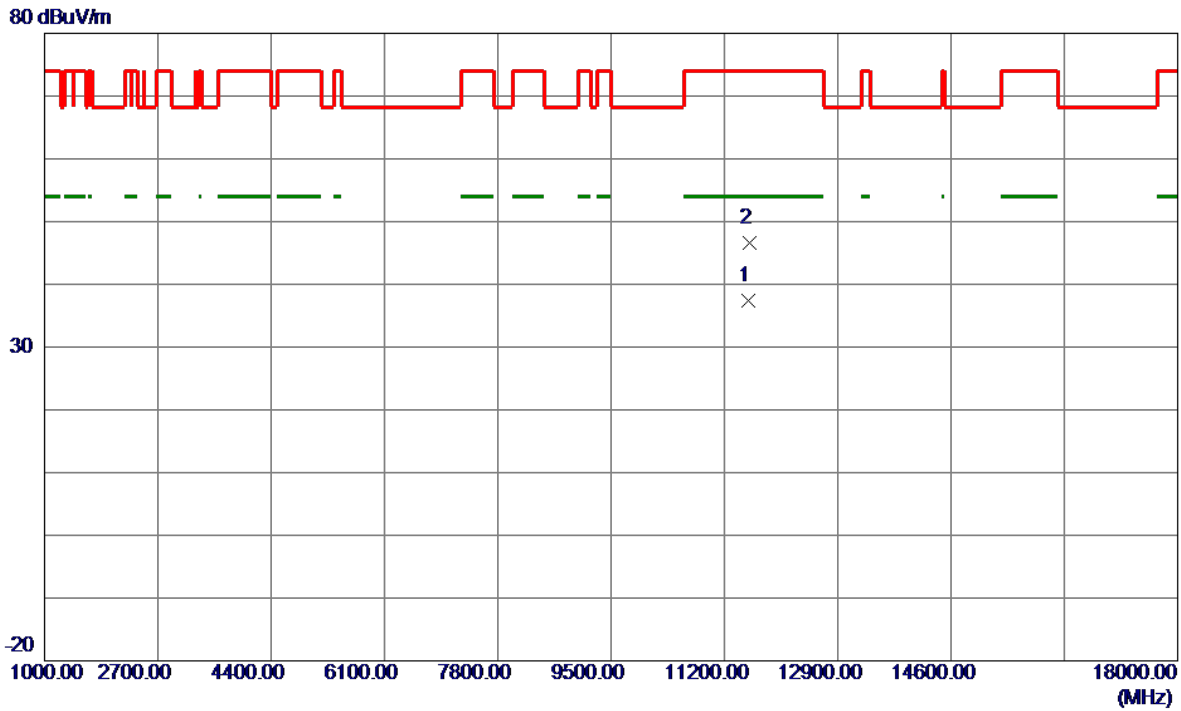

No.	Freq. MHz	Reading Level dBuV/m	Correct Factor dB	Measure ment dBuV/m	Limit dBuV/m	Margin dB	Detector	Comment
1 *	11565.2500	29.08	8.40	37.48	54.00	-16.52	AVG	
2	11570.7750	38.27	8.40	46.67	74.00	-27.33	Peak	

REMARKS:

- (1) Measurement Value = Reading Level + Correct Factor.
- (2) Margin Level = Measurement Value - Limit Value.

Test Mode	UNII-3_TX A Mode 5825 MHz	Polarization	Vertical
-----------	---------------------------	--------------	----------

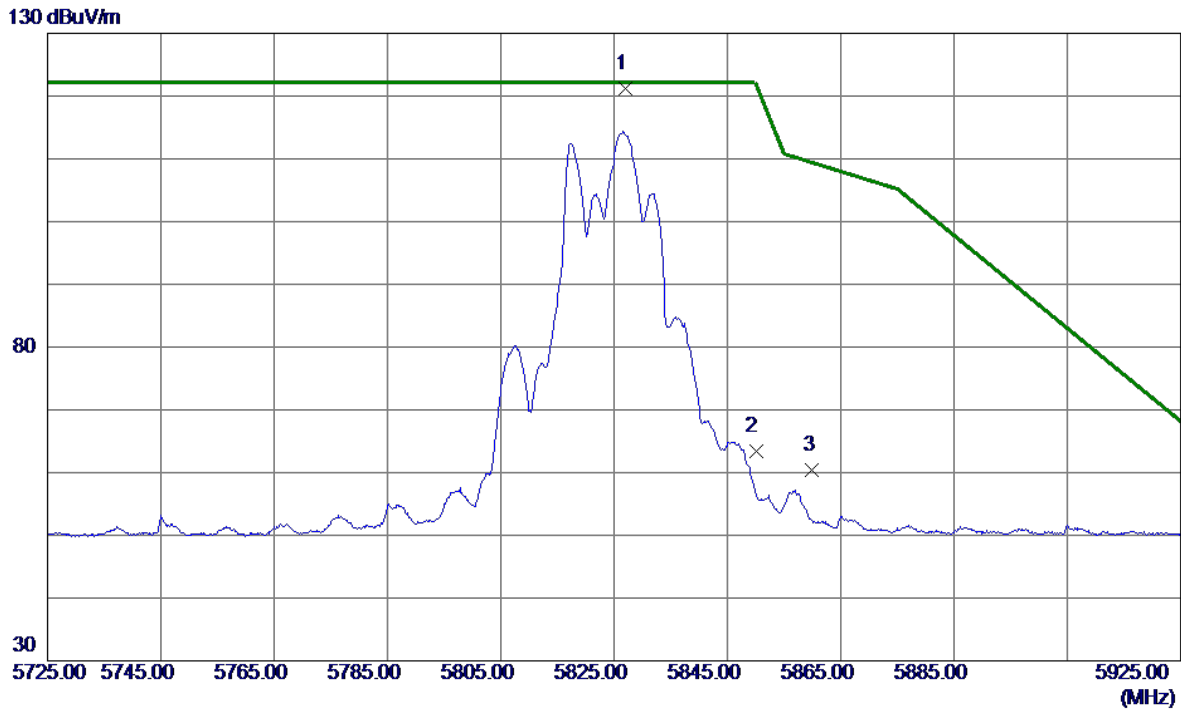

No.	Freq. MHz	Reading Level dBuV/m	Correct Factor dB	Measure ment dBuV/m	Limit dBuV/m	Margin dB	Detector	Comment
1 *	5826.9000	107.79	13.32	121.11	122.20	-1.09	Peak	No Limit
2	5850.0000	50.01	13.40	63.41	122.20	-58.79	Peak	
3	5860.0000	46.98	13.43	60.41	109.40	-48.99	Peak	

REMARKS:

- (1) Measurement Value = Reading Level + Correct Factor.
- (2) Margin Level = Measurement Value - Limit Value.

Test Mode	UNII-3_TX A Mode 5825 MHz	Polarization	Horizontal
-----------	---------------------------	--------------	------------

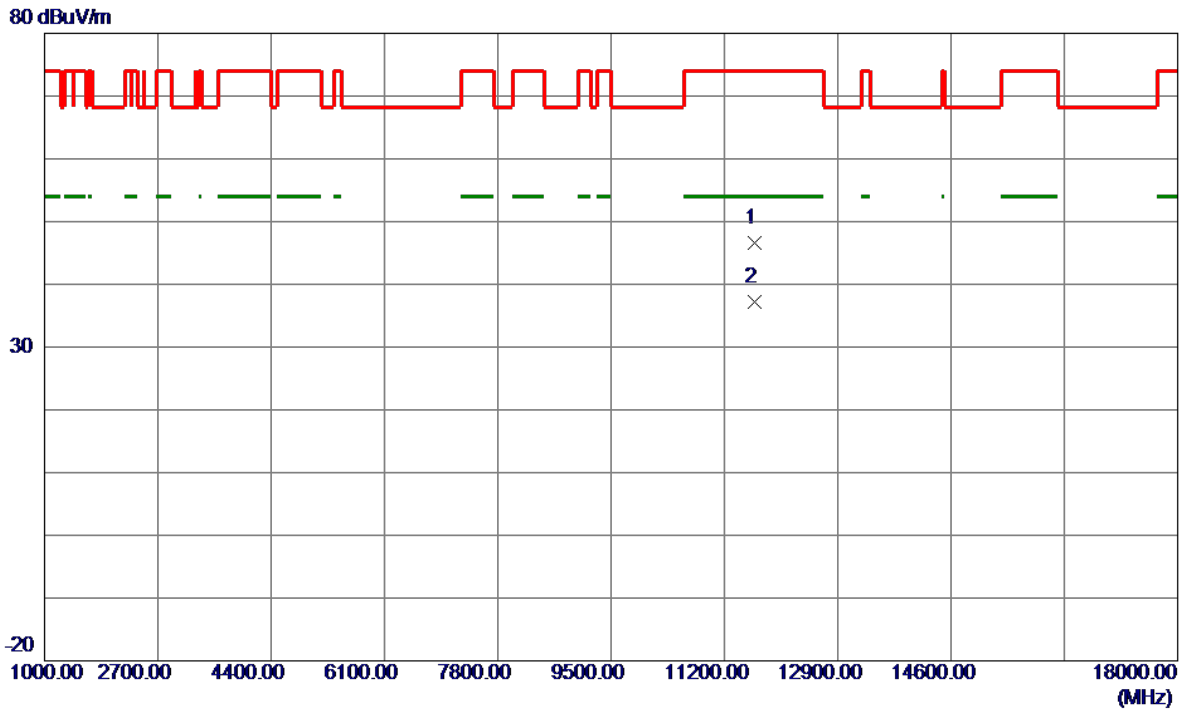

No.	Freq. MHz	Reading Level dBuV/m	Correct Factor dB	Measure ment dBuV/m	Limit dBuV/m	Margin dB	Detector	Comment
1	11654.0250	38.20	8.32	46.52	74.00	-27.48	Peak	
2 *	11655.0250	28.92	8.32	37.24	54.00	-16.76	AVG	

REMARKS:

- (1) Measurement Value = Reading Level + Correct Factor.
- (2) Margin Level = Measurement Value - Limit Value.

Test Mode	UNII-3_TX AC(VHT20) Mode 5745 MHz	Polarization	Vertical
-----------	-----------------------------------	--------------	----------

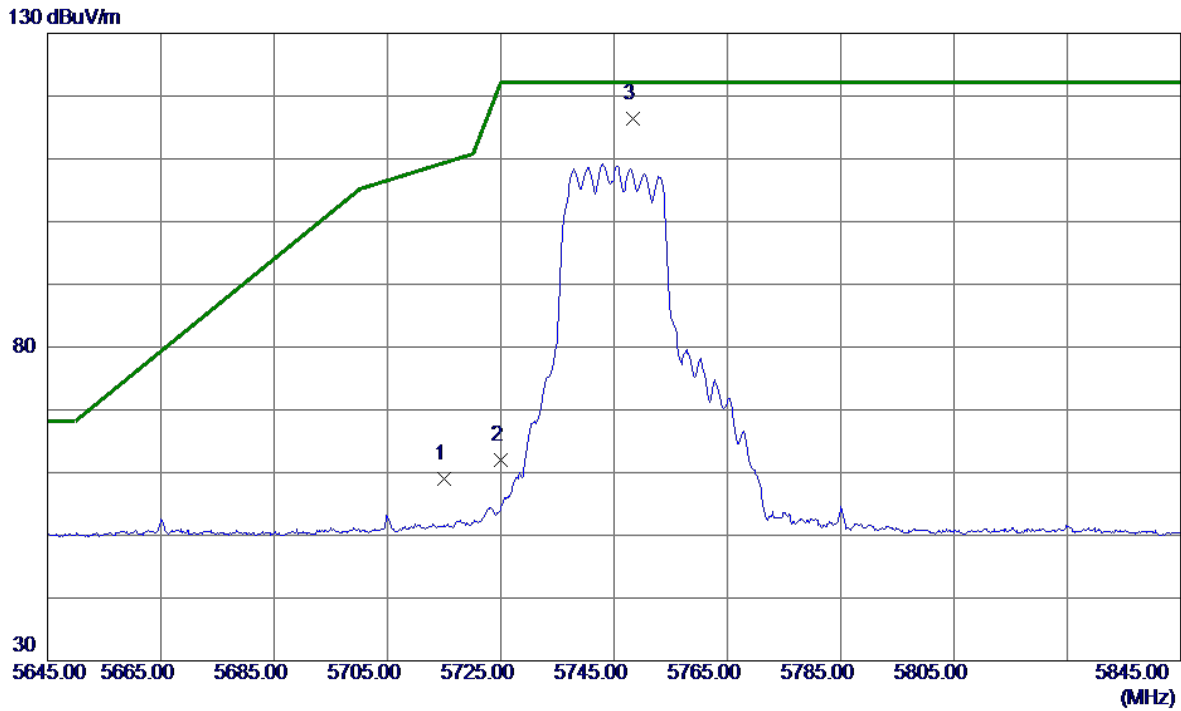

No.	Freq. MHz	Reading Level dBuV/m	Correct Factor dB	Measure ment dBuV/m	Limit dBuV/m	Margin dB	Detector	Comment
1	5715.0000	46.04	12.97	59.01	109.40	-50.39	Peak	
2	5725.0000	49.04	13.00	62.04	122.20	-60.16	Peak	
3 *	5748.3000	103.42	13.07	116.49	122.20	-5.71	Peak	No Limit

REMARKS:

- (1) Measurement Value = Reading Level + Correct Factor.
- (2) Margin Level = Measurement Value - Limit Value.

Test Mode	UNII-3_TX AC(VHT20) Mode 5745 MHz	Polarization	Horizontal
-----------	-----------------------------------	--------------	------------

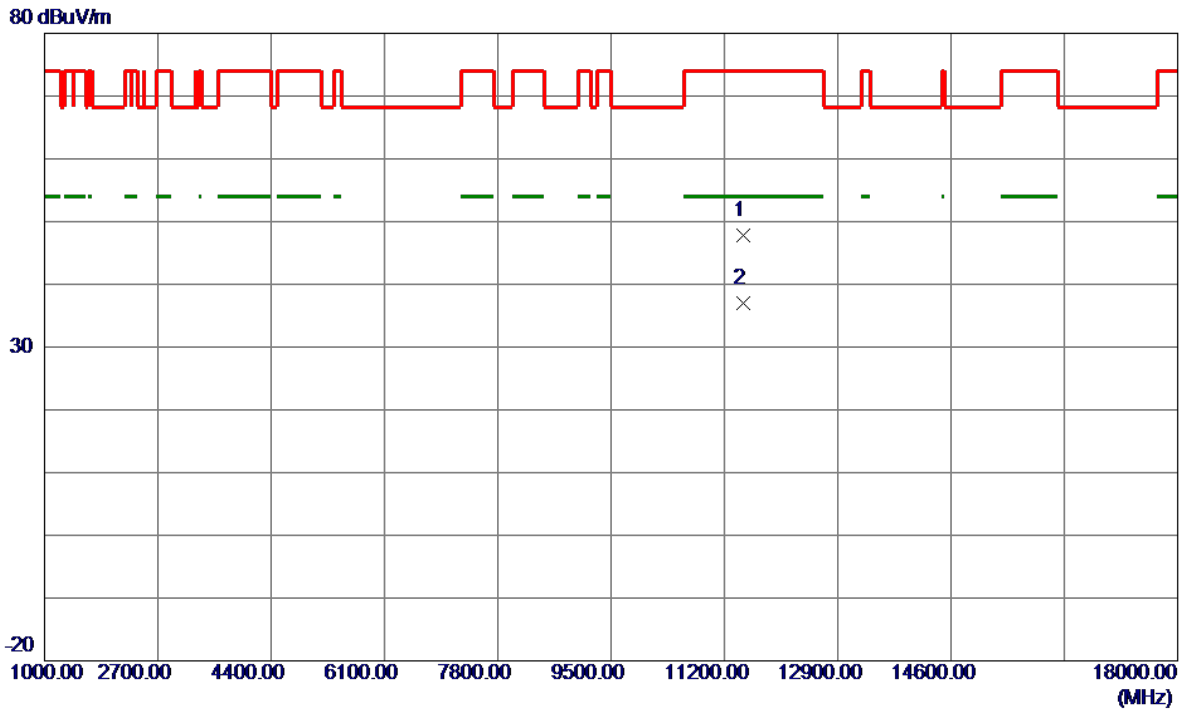

No.	Freq. MHz	Reading Level dBuV/m	Correct Factor dB	Measure ment dBuV/m	Limit dBuV/m	Margin dB	Detector	Comment
1	11486.0250	39.31	8.45	47.76	74.00	-26.24	Peak	
2 *	11491.0750	28.53	8.46	36.99	54.00	-17.01	AVG	

REMARKS:

- (1) Measurement Value = Reading Level + Correct Factor.
- (2) Margin Level = Measurement Value - Limit Value.

Test Mode	UNII-3_TX AC(VHT20) Mode 5785 MHz	Polarization	Horizontal
-----------	-----------------------------------	--------------	------------

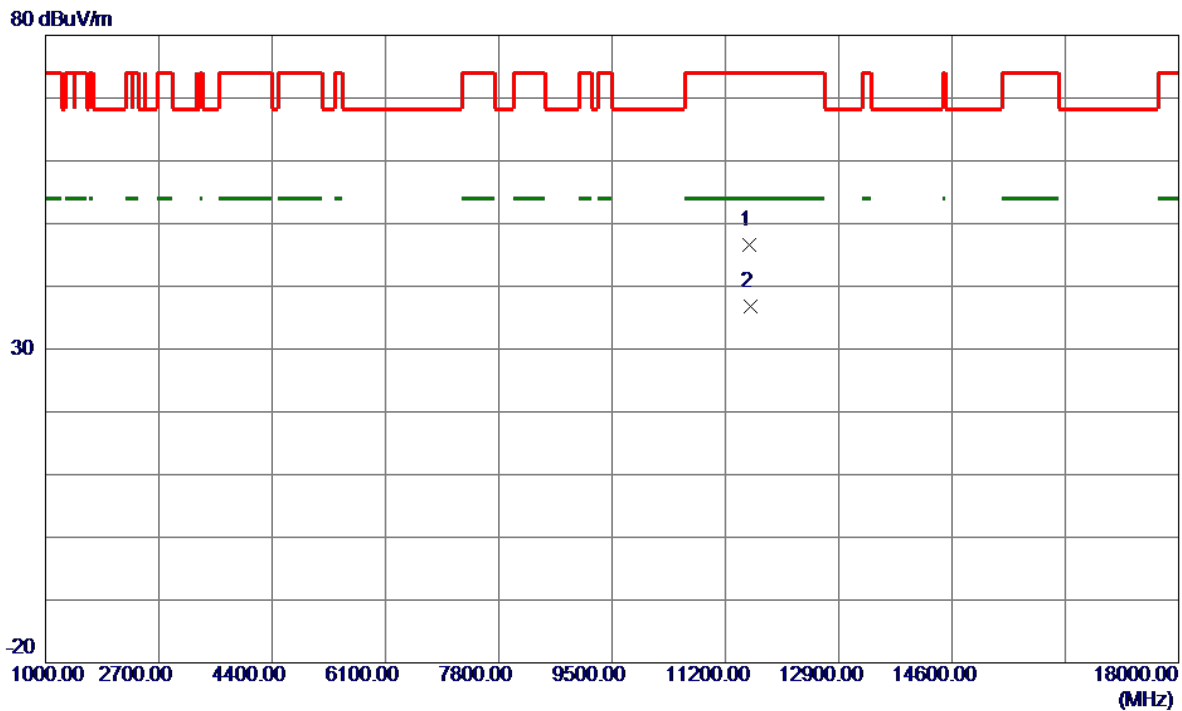

No.	Freq. MHz	Reading Level dBuV/m	Correct Factor dB	Measure ment dBuV/m	Limit dBuV/m	Margin dB	Detector	Comment
1	11556.3750	38.21	8.41	46.62	74.00	-27.38	Peak	
2 *	11571.2250	28.39	8.40	36.79	54.00	-17.21	AVG	

REMARKS:

- (1) Measurement Value = Reading Level + Correct Factor.
- (2) Margin Level = Measurement Value - Limit Value.

Test Mode	UNII-3_TX AC(VHT20) Mode 5825 MHz	Polarization	Vertical
-----------	-----------------------------------	--------------	----------

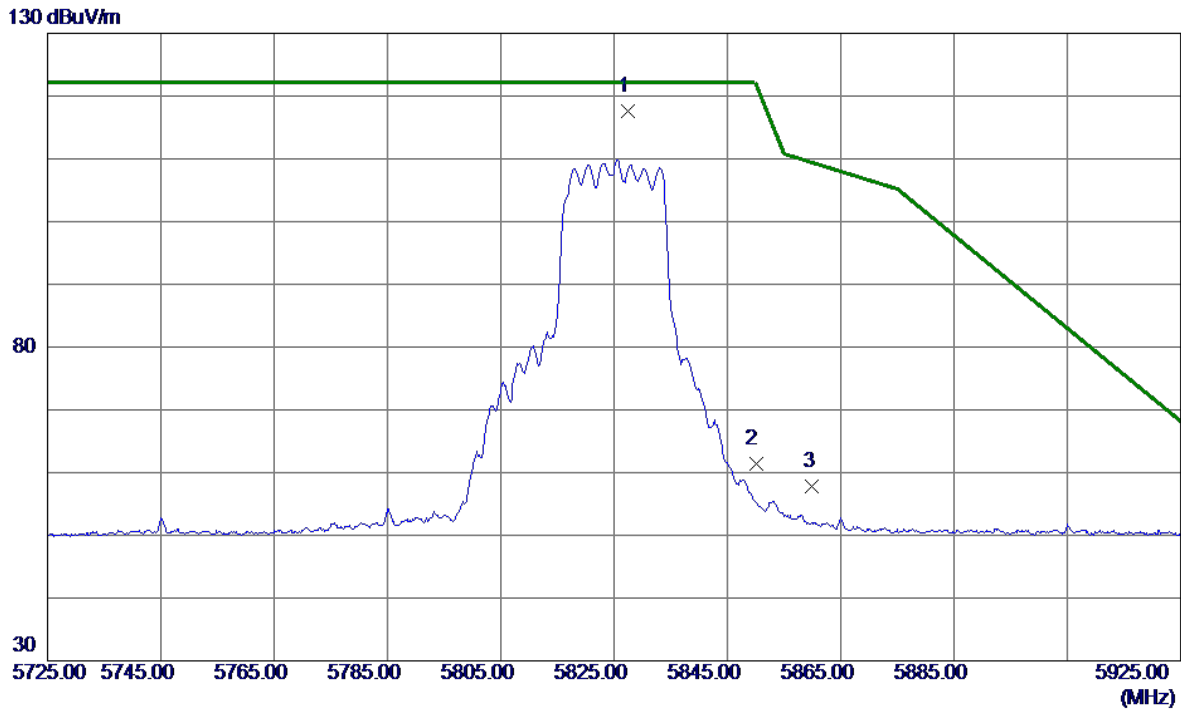

No.	Freq. MHz	Reading Level dBuV/m	Correct Factor dB	Measure ment dBuV/m	Limit dBuV/m	Margin dB	Detector	Comment
1 *	5827.5000	104.30	13.33	117.63	122.20	-4.57	Peak	No Limit
2	5850.0000	47.98	13.40	61.38	122.20	-60.82	Peak	
3	5860.0000	44.31	13.43	57.74	109.40	-51.66	Peak	

REMARKS:

- (1) Measurement Value = Reading Level + Correct Factor.
- (2) Margin Level = Measurement Value - Limit Value.

Test Mode	UNII-3_TX AC(VHT20) Mode 5825 MHz	Polarization	Horizontal
-----------	-----------------------------------	--------------	------------

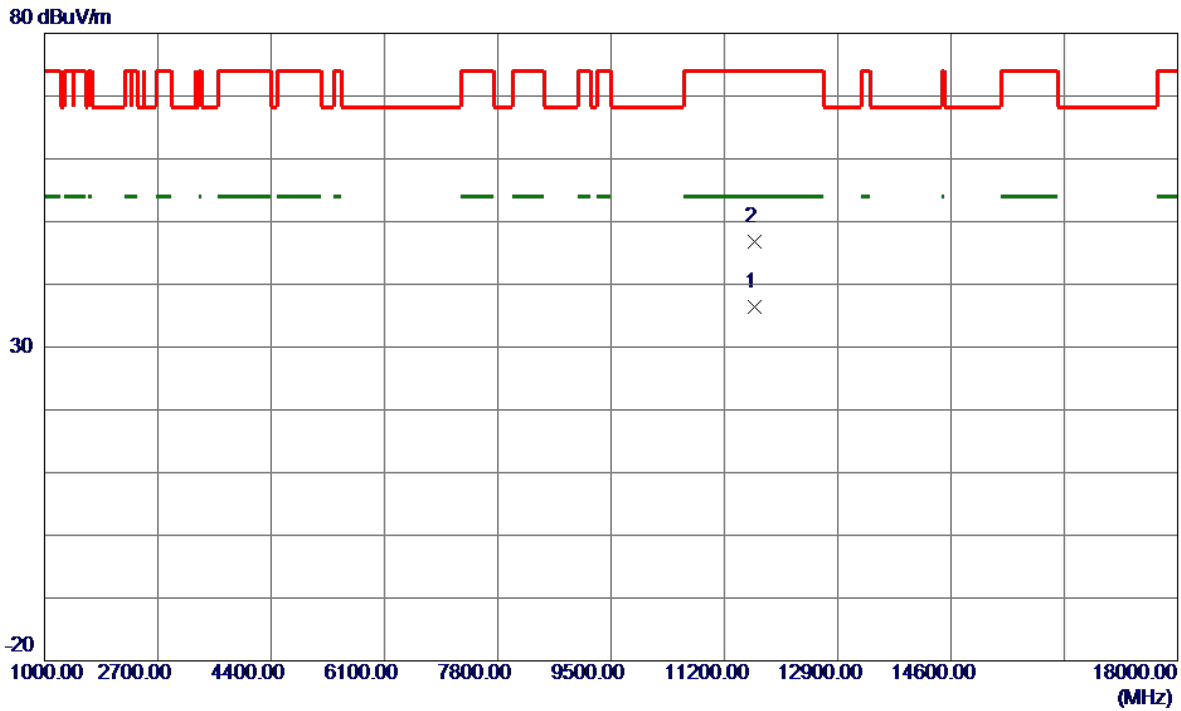

No.	Freq. MHz	Reading Level dBuV/m	Correct Factor dB	Measure ment dBuV/m	Limit dBuV/m	Margin dB	Detector	Comment
1 *	11652.5750	28.01	8.32	36.33	54.00	-17.67	AVG	
2	11653.7750	38.51	8.32	46.83	74.00	-27.17	Peak	

REMARKS:

- (1) Measurement Value = Reading Level + Correct Factor.
- (2) Margin Level = Measurement Value - Limit Value.

Test Mode	UNII-3_TX AC(VHT40) Mode 5755 MHz	Polarization	Vertical
-----------	-----------------------------------	--------------	----------

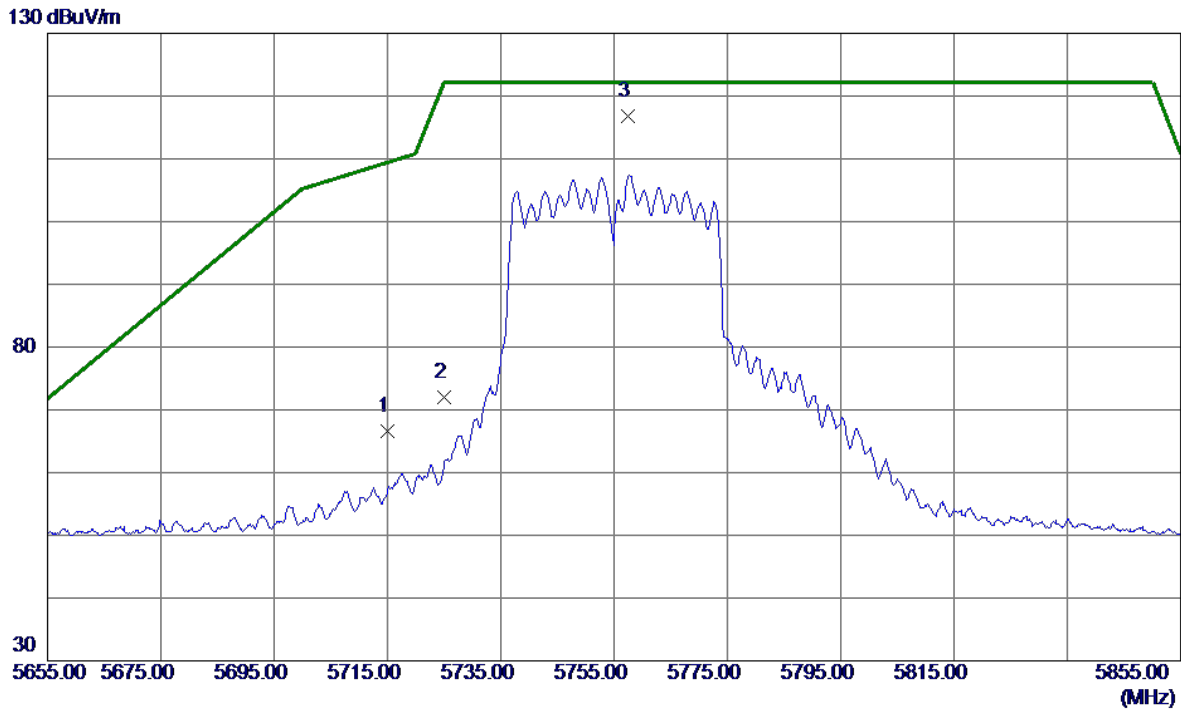

No.	Freq. MHz	Reading Level dBuV/m	Correct Factor dB	Measure ment dBuV/m	Limit dBuV/m	Margin dB	Detector	Comment
1	5715.0000	53.57	12.97	66.54	109.40	-42.86	Peak	
2	5725.0000	59.01	13.00	72.01	122.20	-50.19	Peak	
3 *	5757.4000	103.66	13.10	116.76	122.20	-5.44	Peak	No Limit

REMARKS:

- (1) Measurement Value = Reading Level + Correct Factor.
- (2) Margin Level = Measurement Value - Limit Value.

Test Mode	UNII-3_TX AC(VHT40) Mode 5755 MHz	Polarization	Horizontal
-----------	-----------------------------------	--------------	------------

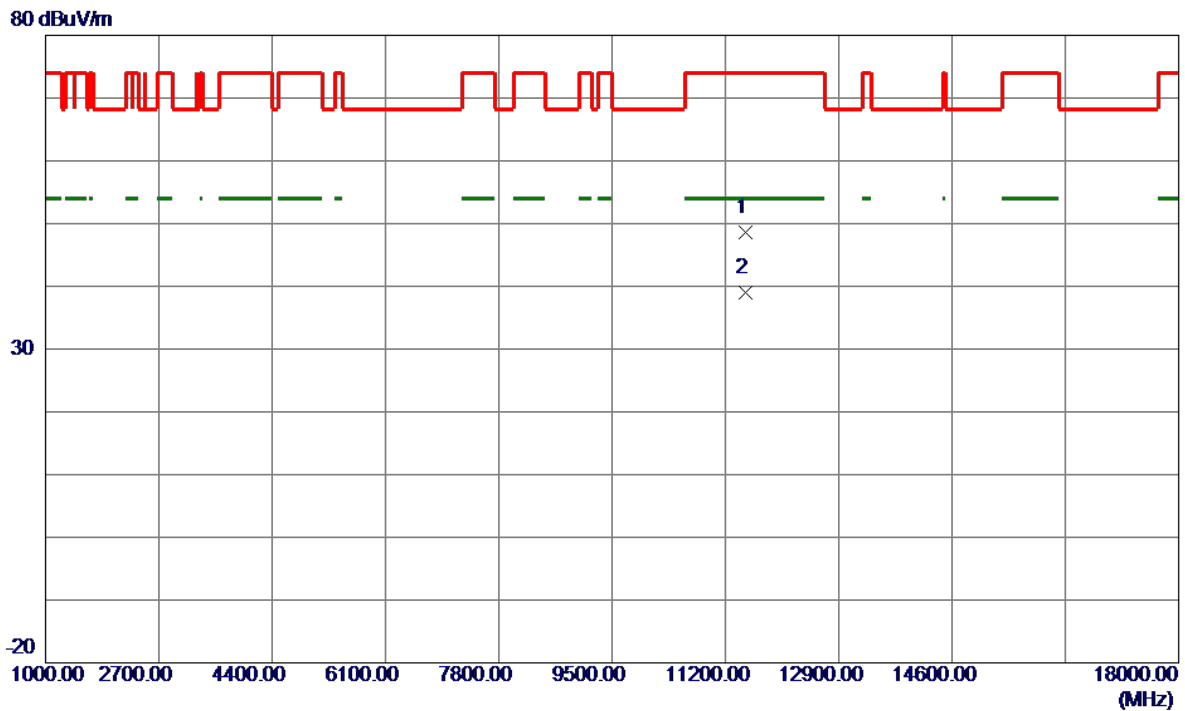

No.	Freq. MHz	Reading Level dBuV/m	Correct Factor dB	Measure ment dBuV/m	Limit dBuV/m	Margin dB	Detector	Comment
1	11497.9500	40.23	8.46	48.69	74.00	-25.31	Peak	
2 *	11502.9250	30.59	8.46	39.05	54.00	-14.95	AVG	

REMARKS:

- (1) Measurement Value = Reading Level + Correct Factor.
- (2) Margin Level = Measurement Value - Limit Value.

Test Mode	UNII-3_TX AC(VHT40) Mode 5795 MHz	Polarization	Vertical
-----------	-----------------------------------	--------------	----------

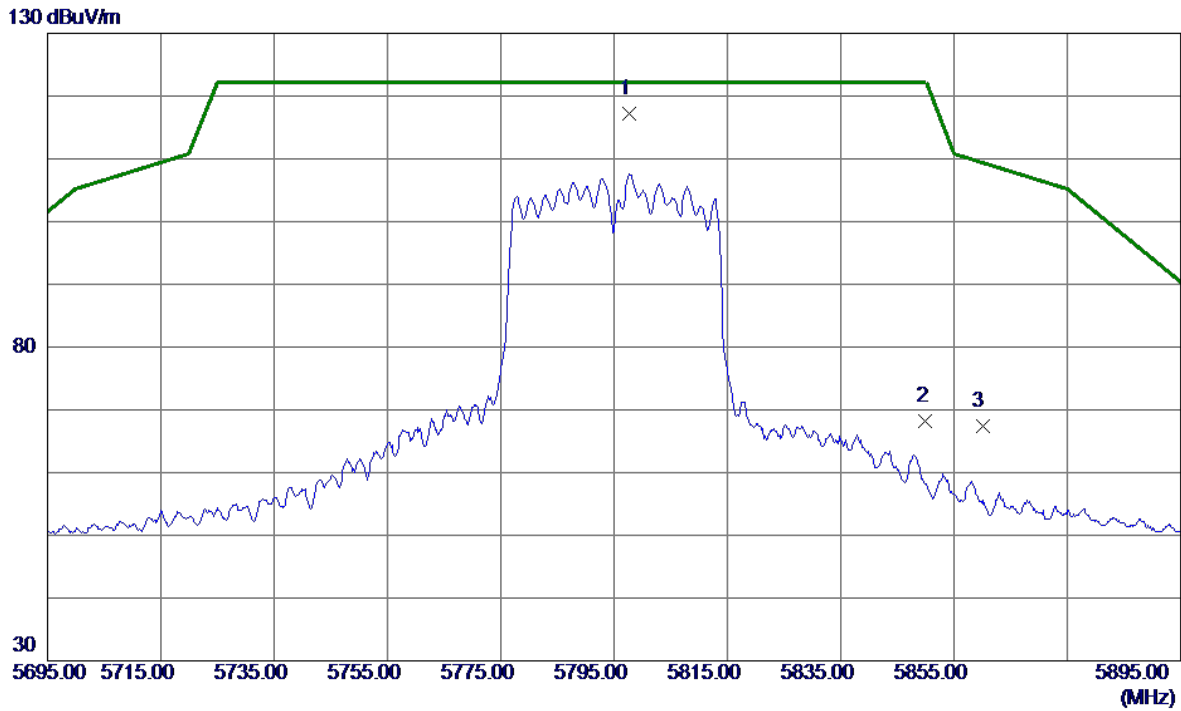

No.	Freq. MHz	Reading Level dBuV/m	Correct Factor dB	Measure ment dBuV/m	Limit dBuV/m	Margin dB	Detector	Comment
1 *	5797.7000	104.02	13.23	117.25	122.20	-4.95	Peak	No Limit
2	5850.0000	54.86	13.40	68.26	122.20	-53.94	Peak	
3	5860.0000	53.99	13.43	67.42	109.40	-41.98	Peak	

REMARKS:

- (1) Measurement Value = Reading Level + Correct Factor.
- (2) Margin Level = Measurement Value - Limit Value.

Test Mode	UNII-3_TX AC(VHT40) Mode 5795 MHz	Polarization	Horizontal
-----------	-----------------------------------	--------------	------------

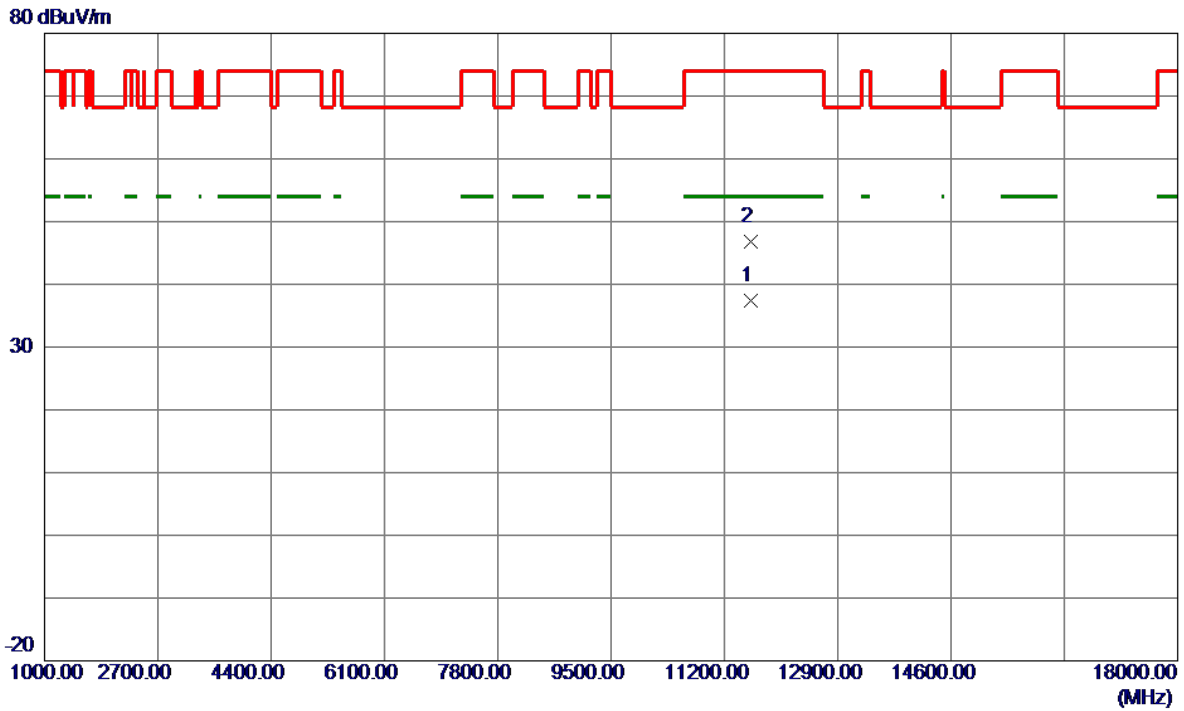

No.	Freq. MHz	Reading Level dBuV/m	Correct Factor dB	Measure ment dBuV/m	Limit dBuV/m	Margin dB	Detector	Comment
1 *	11587.7750	29.04	8.38	37.42	54.00	-16.58	AVG	
2	11592.3750	38.40	8.38	46.78	74.00	-27.22	Peak	

REMARKS:

- (1) Measurement Value = Reading Level + Correct Factor.
- (2) Margin Level = Measurement Value - Limit Value.

Test Mode	UNII-3_TX AC(VHT80) Mode 5775 MHz	Polarization	Vertical
-----------	-----------------------------------	--------------	----------

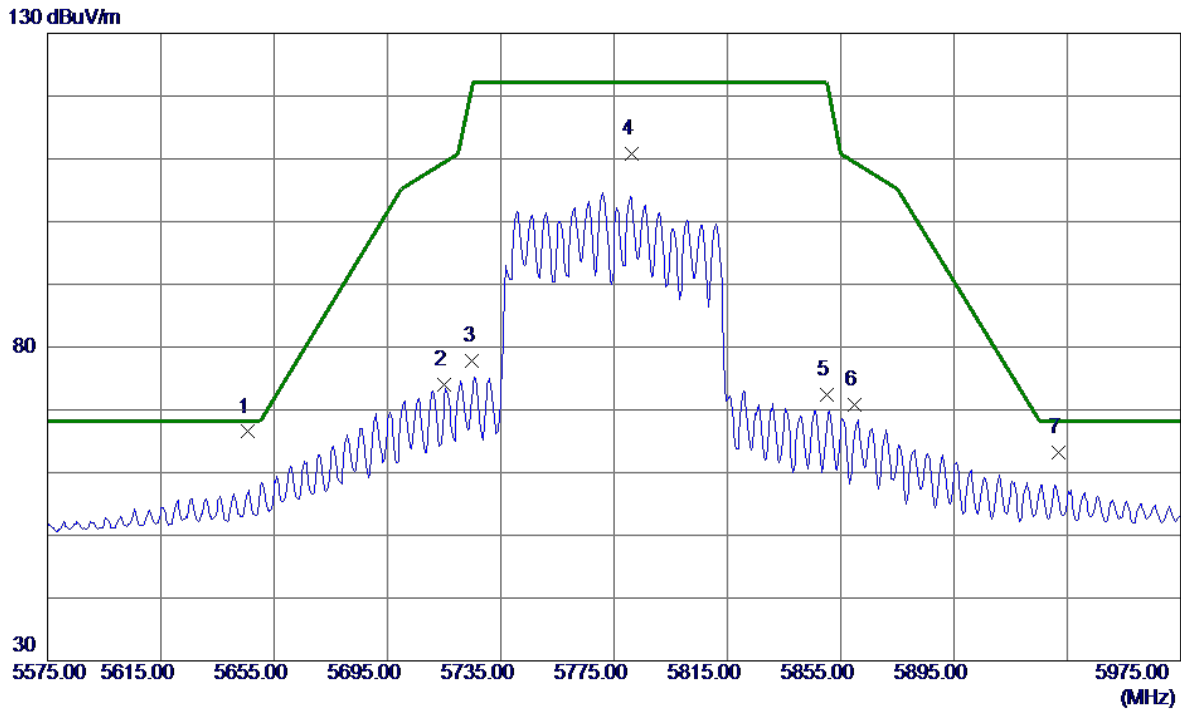

No.	Freq. MHz	Reading Level dBuV/m	Correct Factor dB	Measure ment dBuV/m	Limit dBuV/m	Margin dB	Detector	Comment
1 *	5645.6000	53.76	12.74	66.50	68.20	-1.70	Peak	
2	5715.0000	60.96	12.97	73.93	109.40	-35.47	Peak	
3	5725.0000	64.83	13.00	77.83	122.20	-44.37	Peak	
4	5781.2000	97.69	13.18	110.87	122.20	-11.33	Peak	No Limit
5	5850.0000	58.96	13.40	72.36	122.20	-49.84	Peak	
6	5860.0000	57.31	13.43	70.74	109.40	-38.66	Peak	
7	5932.0000	49.54	13.66	63.20	68.20	-5.00	Peak	

REMARKS:

- (1) Measurement Value = Reading Level + Correct Factor.
- (2) Margin Level = Measurement Value - Limit Value.

Test Mode	UNII-3_TX AC(VHT80) Mode 5775 MHz	Polarization	Horizontal
-----------	-----------------------------------	--------------	------------

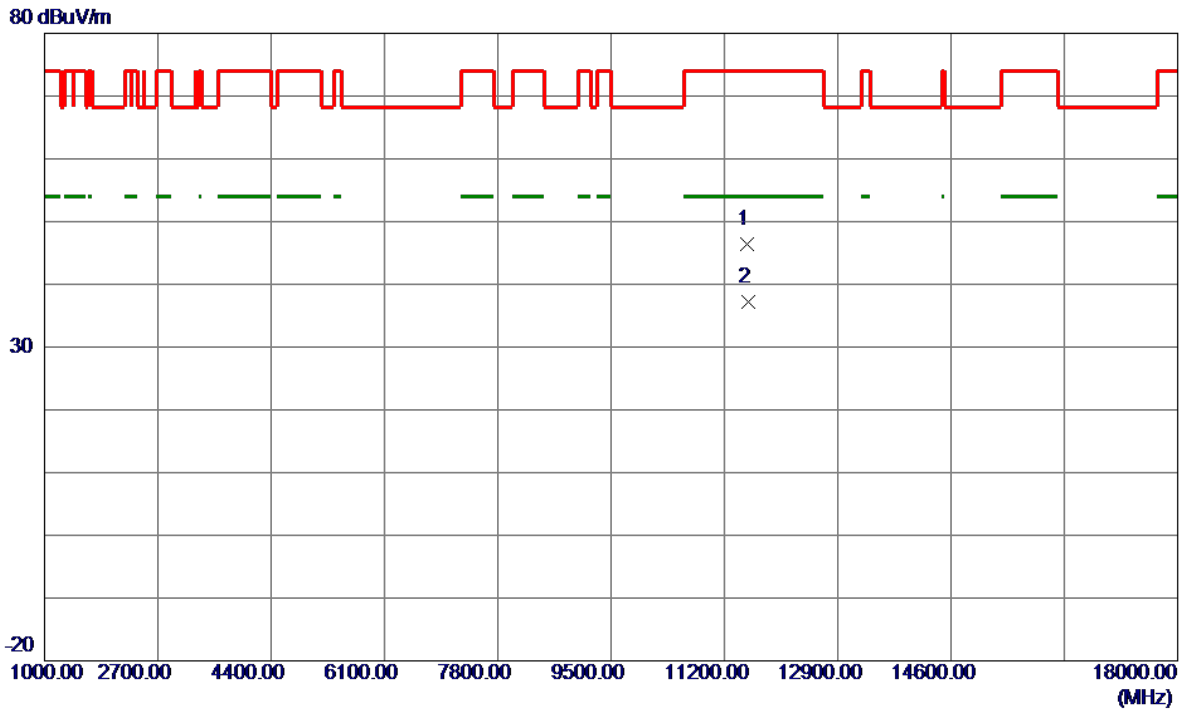

No.	Freq. MHz	Reading Level dBuV/m	Correct Factor dB	Measure ment dBuV/m	Limit dBuV/m	Margin dB	Detector	Comment
1	11549.0500	37.99	8.42	46.41	74.00	-27.59	Peak	
2 *	11563.4500	28.75	8.40	37.15	54.00	-16.85	AVG	

REMARKS:

- (1) Measurement Value = Reading Level + Correct Factor.
- (2) Margin Level = Measurement Value - Limit Value.

Test Mode	UNII-3_TX AX(HE20) Mode 5745 MHz	Polarization	Vertical
-----------	----------------------------------	--------------	----------

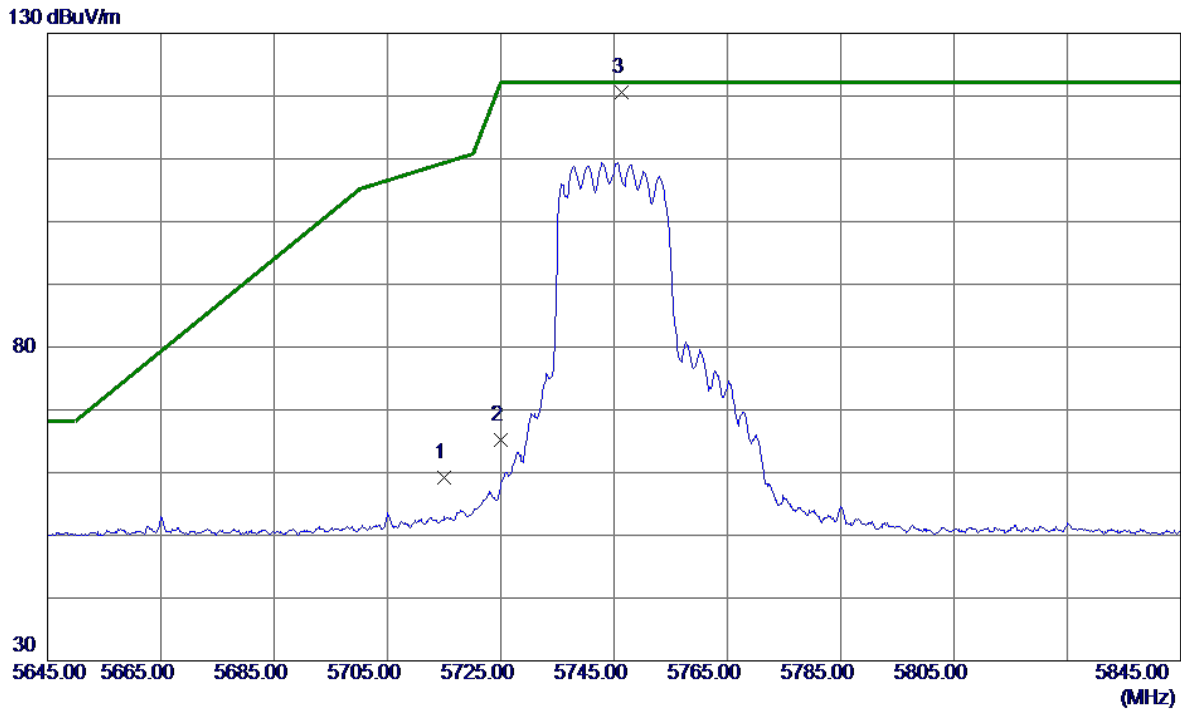

No.	Freq. MHz	Reading Level dBuV/m	Correct Factor dB	Measure ment dBuV/m	Limit dBuV/m	Margin dB	Detector	Comment
1	5715.0000	46.16	12.97	59.13	109.40	-50.27	Peak	
2	5725.0000	52.24	13.00	65.24	122.20	-56.96	Peak	
3 *	5746.4000	107.61	13.07	120.68	122.20	-1.52	Peak	No Limit

REMARKS:

- (1) Measurement Value = Reading Level + Correct Factor.
- (2) Margin Level = Measurement Value - Limit Value.

Test Mode	UNII-3_TX AX(HE20) Mode 5745 MHz	Polarization	Horizontal
-----------	----------------------------------	--------------	------------

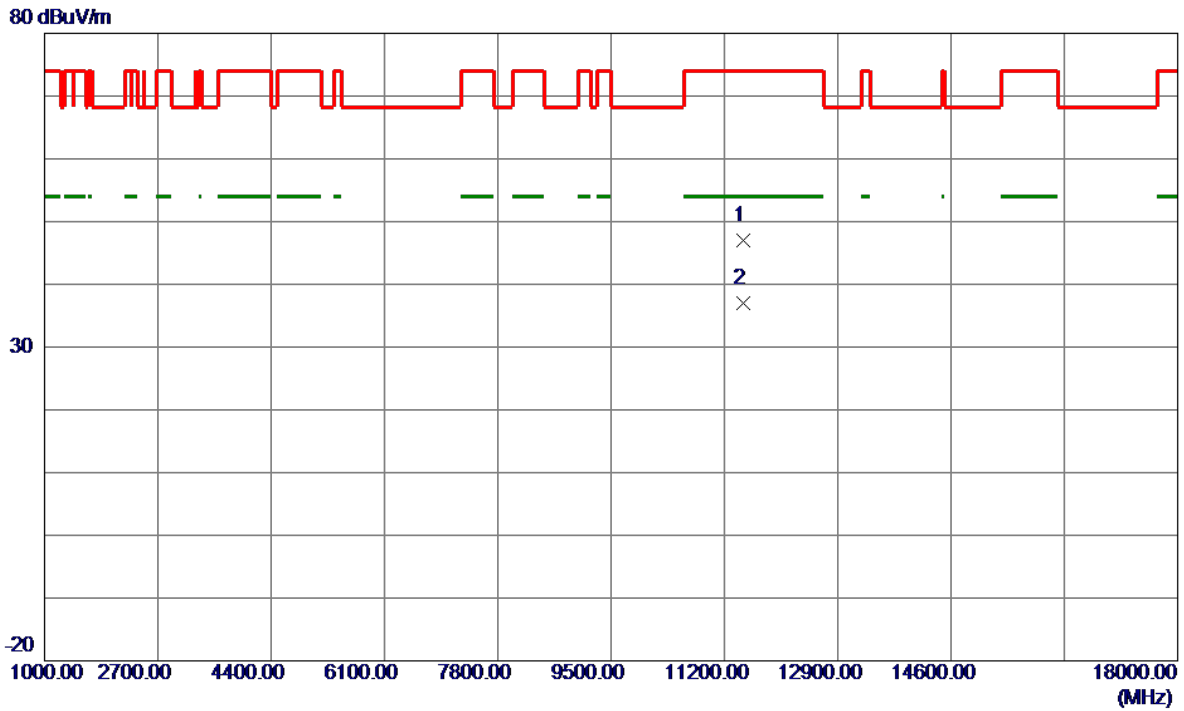

No.	Freq. MHz	Reading Level dBuV/m	Correct Factor dB	Measure ment dBuV/m	Limit dBuV/m	Margin dB	Detector	Comment
1	11484.5500	38.59	8.45	47.04	74.00	-26.96	Peak	
2 *	11491.3000	28.60	8.46	37.06	54.00	-16.94	AVG	

REMARKS:

- (1) Measurement Value = Reading Level + Correct Factor.
- (2) Margin Level = Measurement Value - Limit Value.

Test Mode	UNII-3_TX AX(HE20) Mode 5785 MHz	Polarization	Horizontal
-----------	----------------------------------	--------------	------------

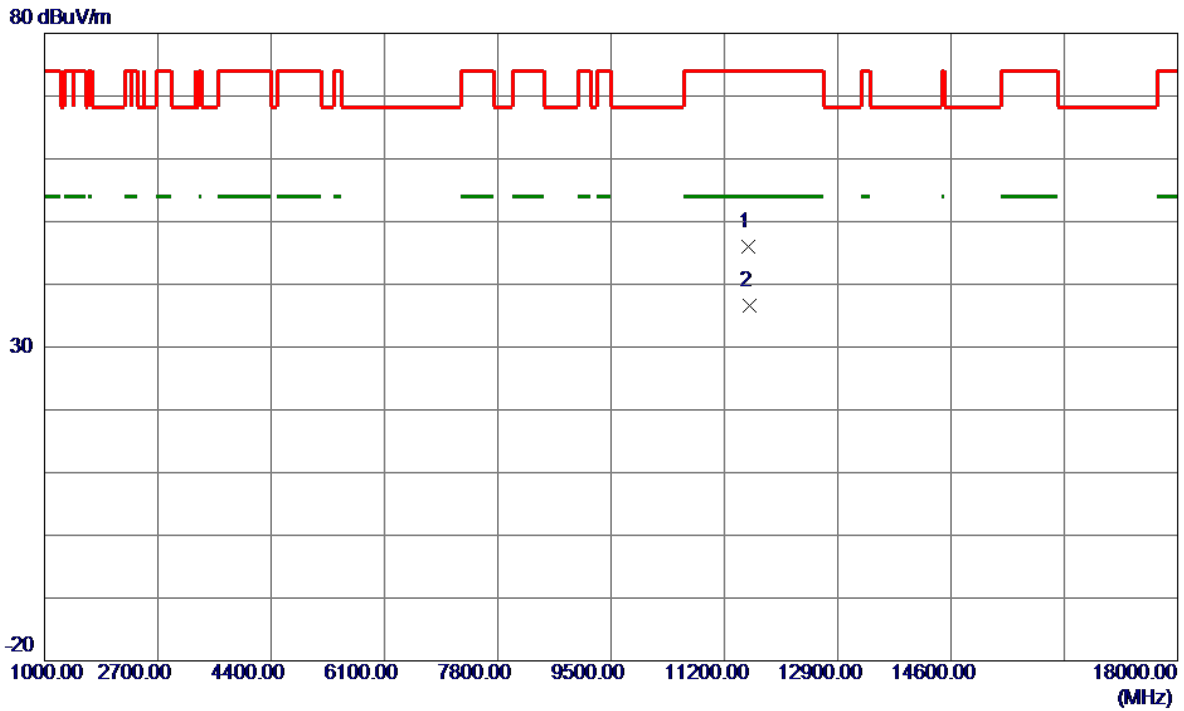

No.	Freq. MHz	Reading Level dBuV/m	Correct Factor dB	Measure ment dBuV/m	Limit dBuV/m	Margin dB	Detector	Comment
1	11561.6750	37.60	8.41	46.01	74.00	-27.99	Peak	
2 *	11571.3500	28.27	8.40	36.67	54.00	-17.33	AVG	

REMARKS:

- (1) Measurement Value = Reading Level + Correct Factor.
- (2) Margin Level = Measurement Value - Limit Value.

Test Mode	UNII-3_TX AX(HE20) Mode 5825 MHz	Polarization	Vertical
-----------	----------------------------------	--------------	----------

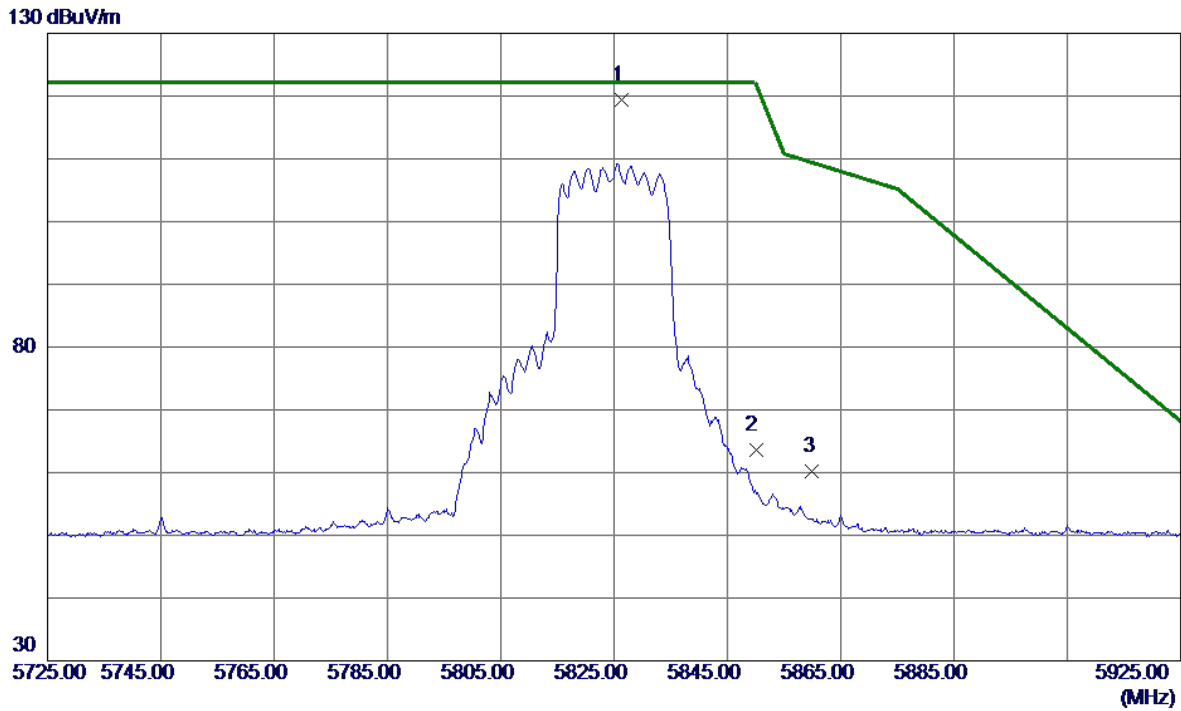

No.	Freq. MHz	Reading Level dBuV/m	Correct Factor dB	Measure ment dBuV/m	Limit dBuV/m	Margin dB	Detector	Comment
1 *	5826.4000	106.07	13.32	119.39	122.20	-2.81	Peak	No Limit
2	5850.0000	50.12	13.40	63.52	122.20	-58.68	Peak	
3	5860.0000	46.72	13.43	60.15	109.40	-49.25	Peak	

REMARKS:

- (1) Measurement Value = Reading Level + Correct Factor.
- (2) Margin Level = Measurement Value - Limit Value.

Test Mode	UNII-3_TX AX(HE20) Mode 5825 MHz	Polarization	Horizontal
-----------	----------------------------------	--------------	------------

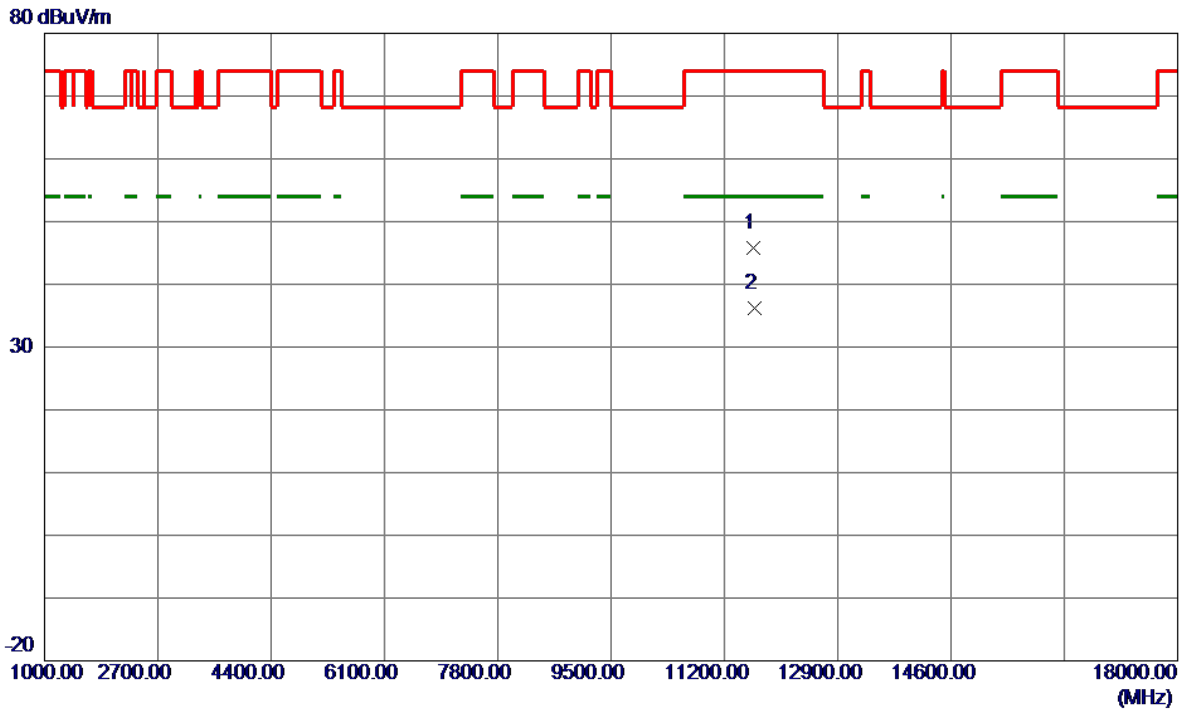

No.	Freq. MHz	Reading Level dBuV/m	Correct Factor dB	Measure ment dBuV/m	Limit dBuV/m	Margin dB	Detector	Comment
1	11631.8500	37.38	8.34	45.72	74.00	-28.28	Peak	
2 *	11651.3750	27.81	8.32	36.13	54.00	-17.87	AVG	

REMARKS:

- (1) Measurement Value = Reading Level + Correct Factor.
- (2) Margin Level = Measurement Value - Limit Value.

Test Mode	UNII-3_TX AX(HE40) Mode 5755 MHz	Polarization	Vertical
-----------	----------------------------------	--------------	----------

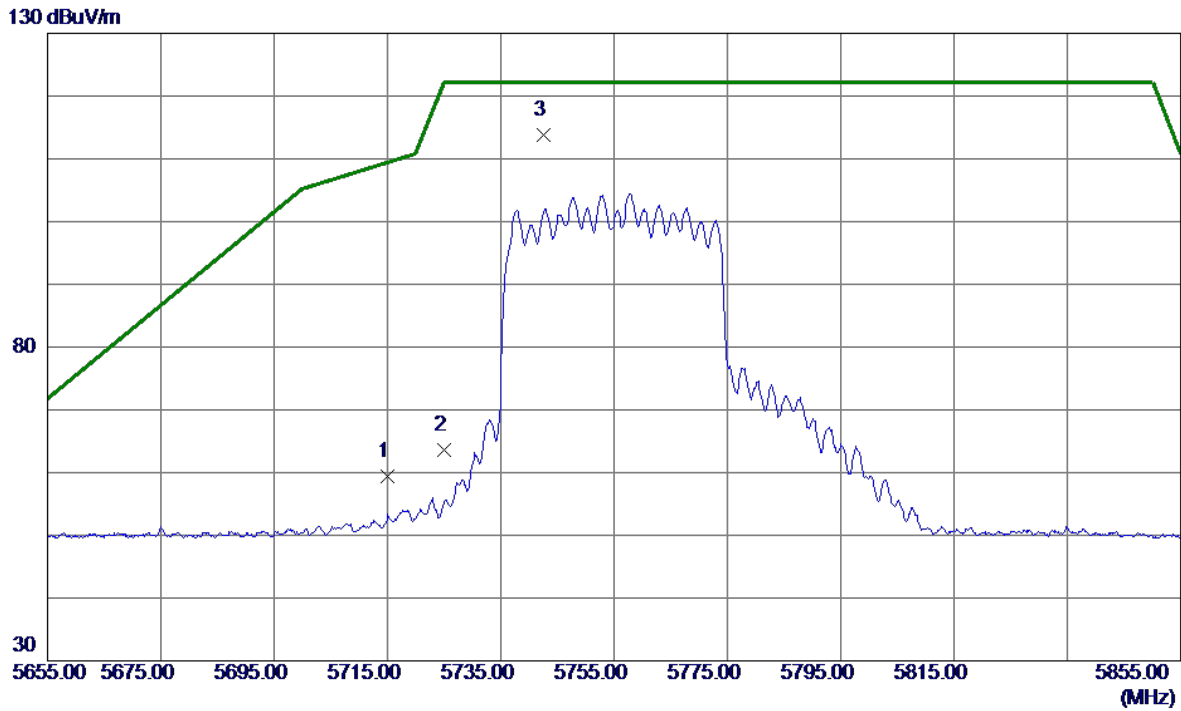

No.	Freq. MHz	Reading Level dBuV/m	Correct Factor dB	Measure ment dBuV/m	Limit dBuV/m	Margin dB	Detector	Comment
1	5715.0000	46.45	12.97	59.42	109.40	-49.98	Peak	
2	5725.0000	50.52	13.00	63.52	122.20	-58.68	Peak	
3 *	5742.5000	100.74	13.05	113.79	122.20	-8.41	Peak	No Limit

REMARKS:

- (1) Measurement Value = Reading Level + Correct Factor.
- (2) Margin Level = Measurement Value - Limit Value.

Test Mode	UNII-3_TX AX(HE40) Mode 5755 MHz	Polarization	Horizontal
-----------	----------------------------------	--------------	------------

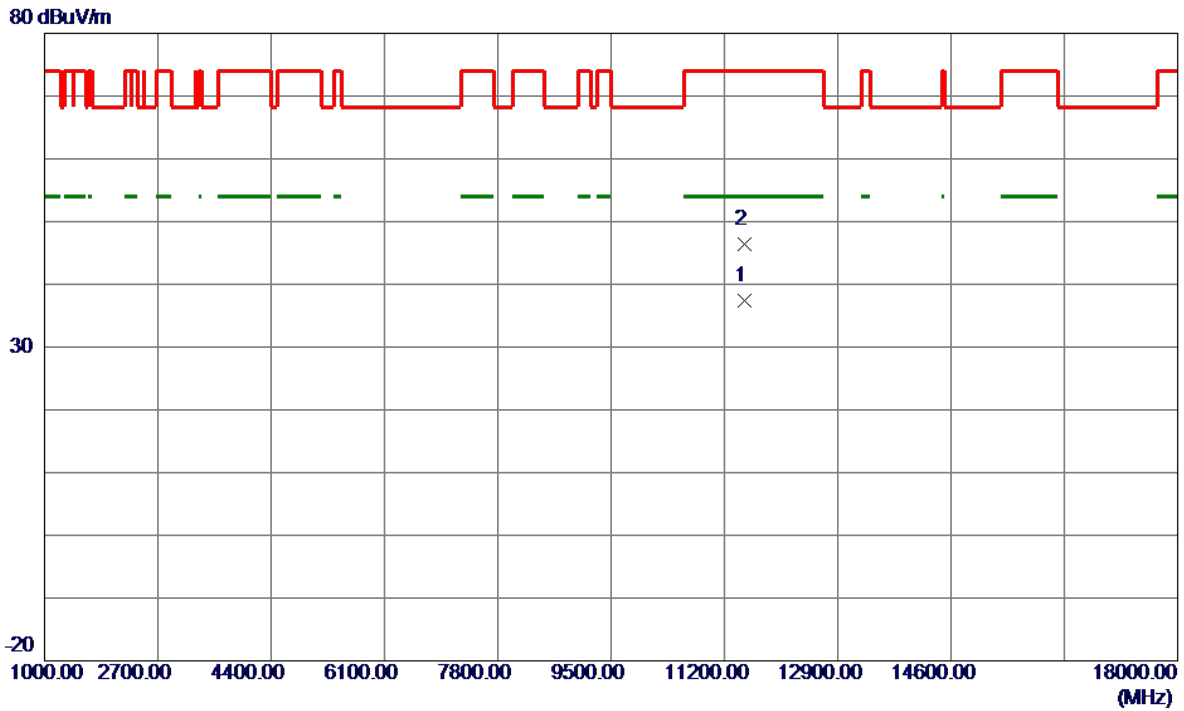

No.	Freq. MHz	Reading Level dBuV/m	Correct Factor dB	Measure ment dBuV/m	Limit dBuV/m	Margin dB	Detector	Comment
1 *	11502.9000	28.98	8.46	37.44	54.00	-16.56	AVG	
2	11511.3500	38.04	8.45	46.49	74.00	-27.51	Peak	

REMARKS:

- (1) Measurement Value = Reading Level + Correct Factor.
- (2) Margin Level = Measurement Value - Limit Value.

Test Mode	UNII-3_TX AX(HE40) Mode 5795 MHz	Polarization	Vertical
-----------	----------------------------------	--------------	----------

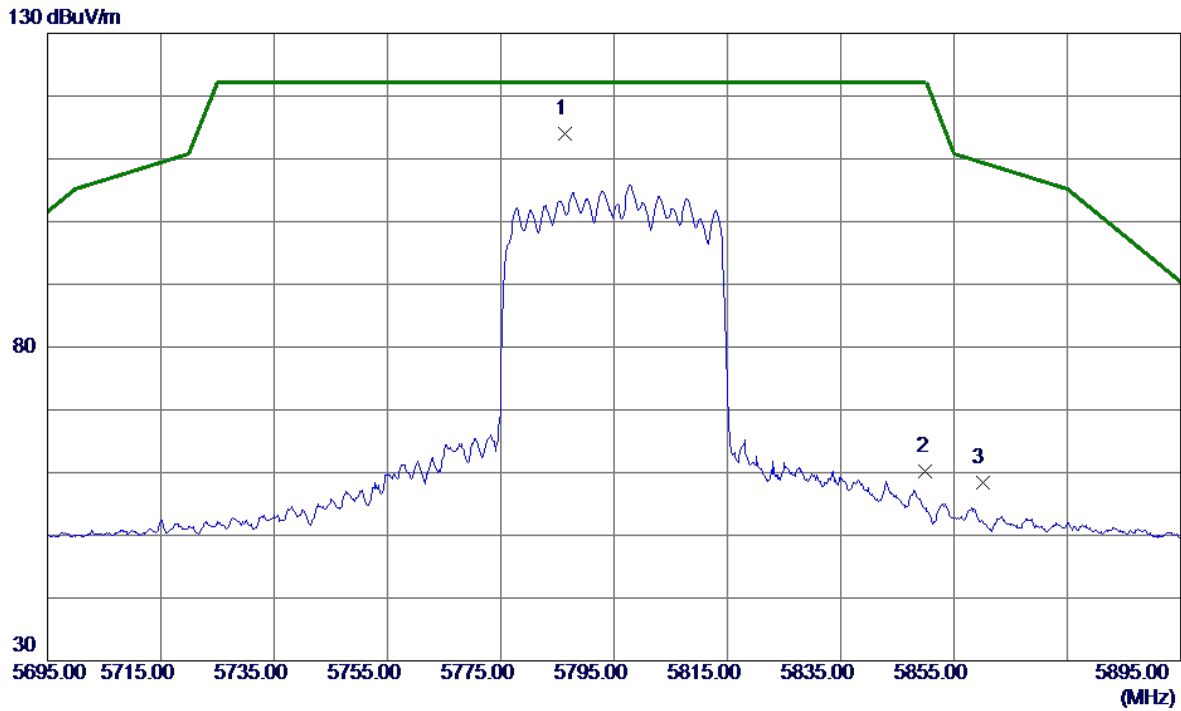

No.	Freq. MHz	Reading Level dBuV/m	Correct Factor dB	Measure ment dBuV/m	Limit dBuV/m	Margin dB	Detector	Comment
1 *	5786.3000	100.71	13.19	113.90	122.20	-8.30	Peak	No Limit
2	5850.0000	46.74	13.40	60.14	122.20	-62.06	Peak	
3	5860.0000	44.93	13.43	58.36	109.40	-51.04	Peak	

REMARKS:

- (1) Measurement Value = Reading Level + Correct Factor.
- (2) Margin Level = Measurement Value - Limit Value.

Test Mode	UNII-3_TX AX(HE40) Mode 5795 MHz	Polarization	Horizontal
-----------	----------------------------------	--------------	------------

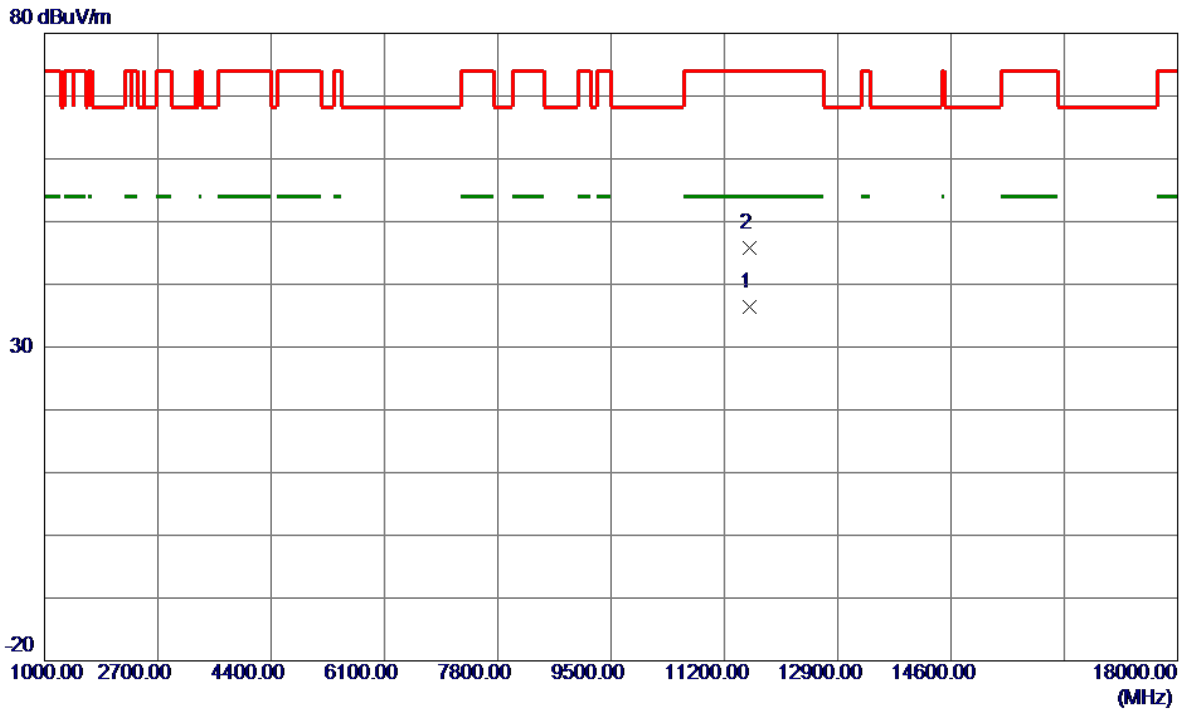

No.	Freq. MHz	Reading Level dBuV/m	Correct Factor dB	Measure ment dBuV/m	Limit dBuV/m	Margin dB	Detector	Comment
1 *	11582.8500	27.94	8.39	36.33	54.00	-17.67	AVG	
2	11585.7000	37.44	8.38	45.82	74.00	-28.18	Peak	

REMARKS:

- (1) Measurement Value = Reading Level + Correct Factor.
- (2) Margin Level = Measurement Value - Limit Value.

Test Mode	UNII-3_TX AX(HE80) Mode 5775 MHz	Polarization	Vertical
-----------	----------------------------------	--------------	----------

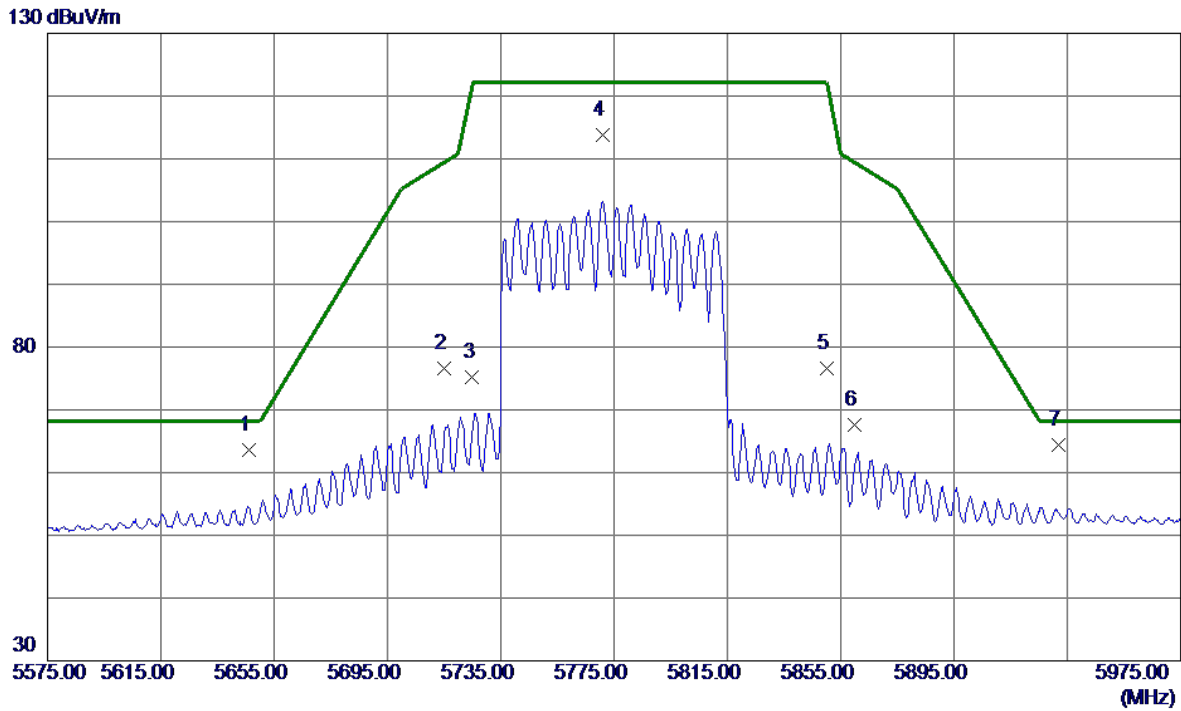

No.	Freq. MHz	Reading Level dBuV/m	Correct Factor dB	Measure ment dBuV/m	Limit dBuV/m	Margin dB	Detector	Comment
1	5646.0000	50.82	12.74	63.56	68.20	-4.64	Peak	
2	5715.0000	63.70	12.97	76.67	109.40	-32.73	Peak	
3	5725.0000	62.11	13.00	75.11	122.20	-47.09	Peak	
4	5770.8000	100.62	13.14	113.76	122.20	-8.44	Peak	No Limit
5	5850.0000	63.24	13.40	76.64	122.20	-45.56	Peak	
6	5860.0000	54.20	13.43	67.63	109.40	-41.77	Peak	
7 *	5931.8000	50.68	13.66	64.34	68.20	-3.86	Peak	

REMARKS:

- (1) Measurement Value = Reading Level + Correct Factor.
- (2) Margin Level = Measurement Value - Limit Value.

Test Mode	UNII-3_TX AX(HE80) Mode 5775 MHz	Polarization	Horizontal
-----------	----------------------------------	--------------	------------

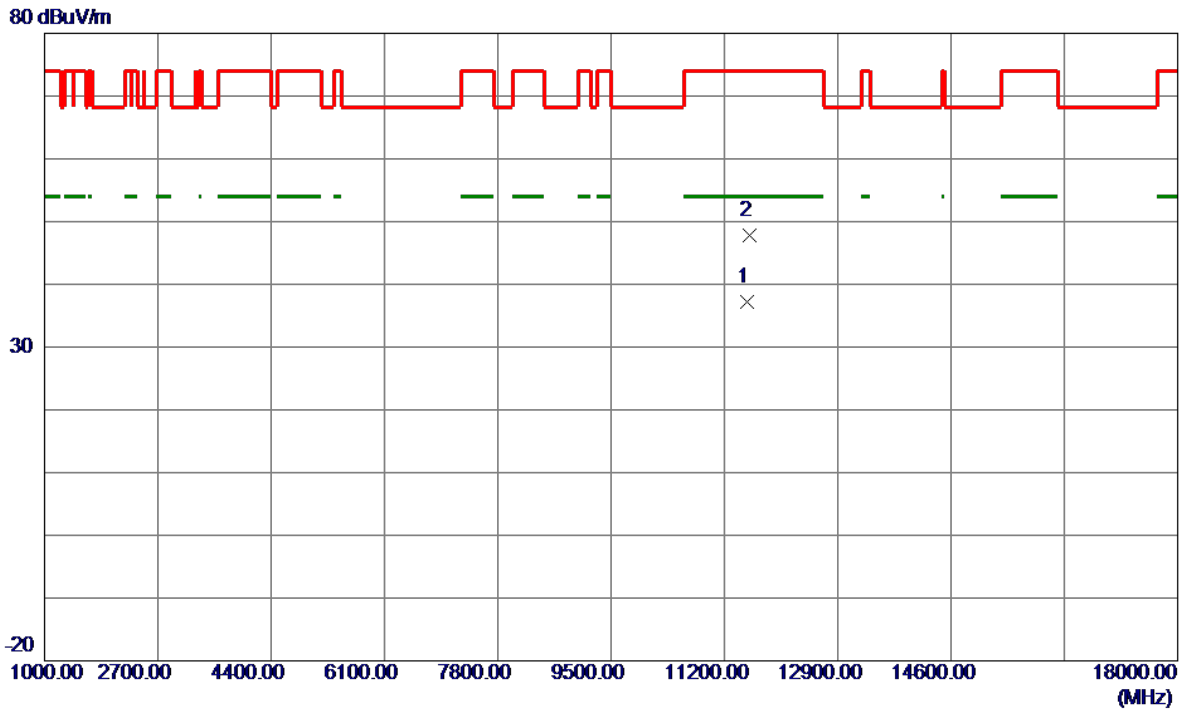

No.	Freq. MHz	Reading Level dBuV/m	Correct Factor dB	Measure ment dBuV/m	Limit dBuV/m	Margin dB	Detector	Comment
1 *	11542.8000	28.74	8.42	37.16	54.00	-16.84	AVG	
2	11572.4500	39.38	8.40	47.78	74.00	-26.22	Peak	

REMARKS:

- (1) Measurement Value = Reading Level + Correct Factor.
- (2) Margin Level = Measurement Value - Limit Value.

Test Mode	TX AX(HE40) Mode Channel 38 (UNII-1)	Polarization	Vertical
-----------	--------------------------------------	--------------	----------

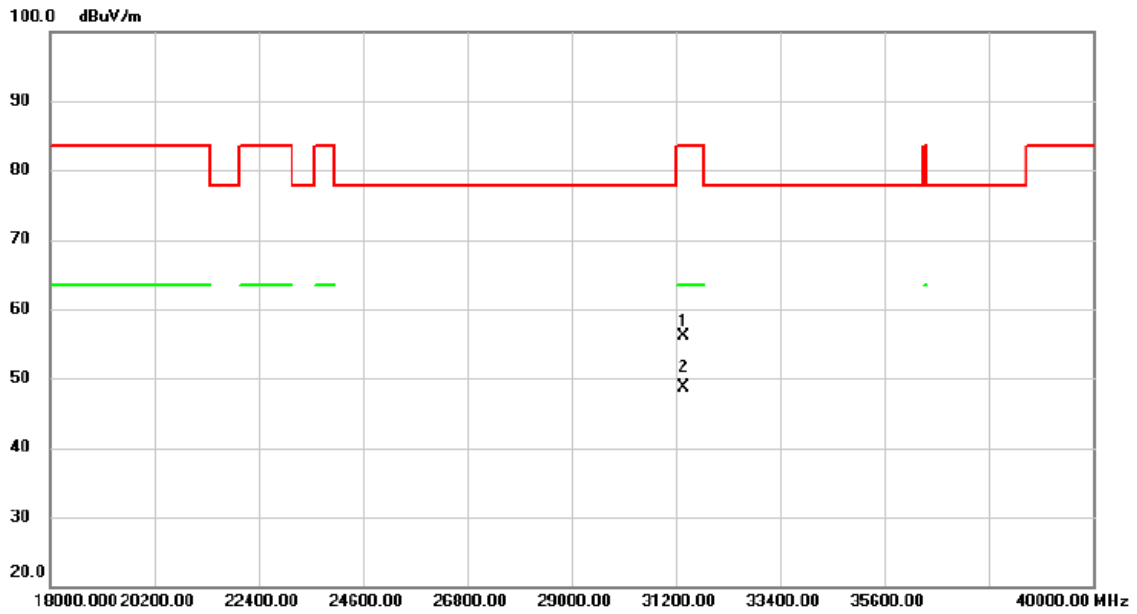

No.	Mk.	Freq. MHz	Reading Level dBuV	Correct Factor dB	Measure- ment dBuV/m	Limit dBuV/m	Margin dB	Detector	Comment
1		31365.00	47.11	8.90	56.01	83.54	-27.53	peak	
2	*	31365.00	39.71	8.90	48.61	63.54	-14.93	AVG	

REMARKS:

- (1) Measurement Value = Reading Level + Correct Factor.
- (2) Margin Level = Measurement Value - Limit Value.

Test Mode	TX AX(HE40) Mode Channel 38 (UNII-1)	Polarization	Horizontal
-----------	--------------------------------------	--------------	------------

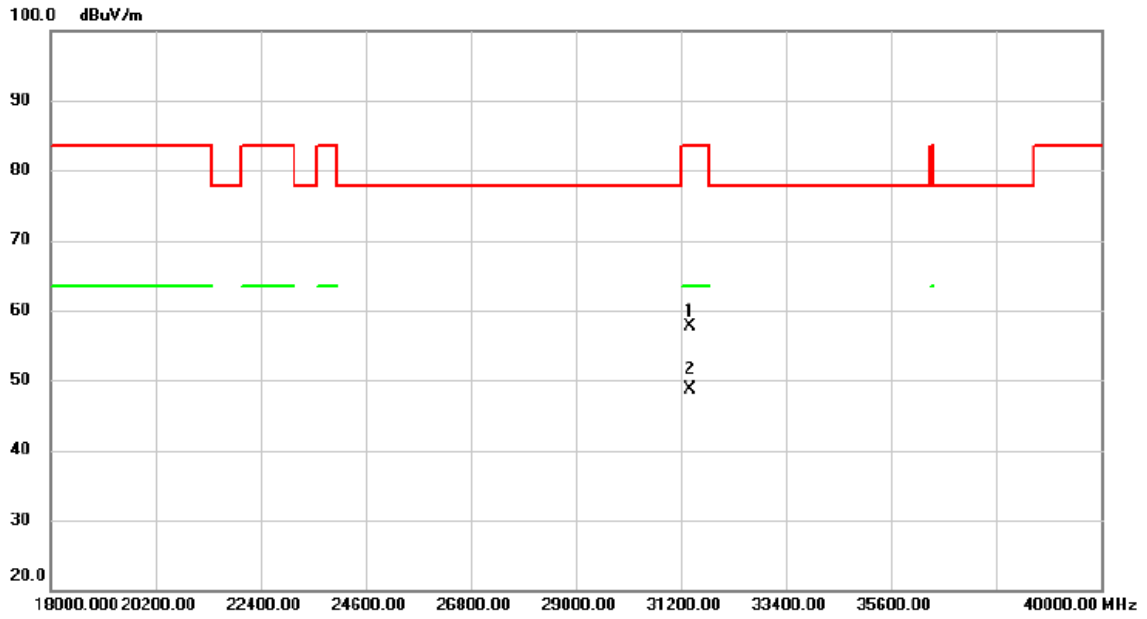

No.	Mk.	Freq. MHz	Reading Level dBuV	Correct Factor dB	Measure- ment dBuV/m	Limit dBuV/m	Margin dB	Detector	Comment
1		31376.00	48.73	8.89	57.62	83.54	-25.92	peak	
2	*	31376.00	39.73	8.89	48.62	63.54	-14.92	AVG	

REMARKS:

- (1) Measurement Value = Reading Level + Correct Factor.
- (2) Margin Level = Measurement Value - Limit Value.

APPENDIX E - BANDWIDTH