



CFR 47 FCC PART 15 SUBPART C(DTS)

TEST REPORT

For

Headset screen

MODEL NUMBER: JH-ANC930PLUS Screen

REPORT NUMBER: E04A24080217F00402

ISSUE DATE: September 6, 2024

FCC ID: 2APRE-JH-ANC930-S

Prepared for

SHENZHEN JIUHU TECHNOLOGY CO., LTD

**4F, HE Sheng Teng Tech Industrial Park, HuanGuan South Road.10 Guanlan,
LongHua, ShenZhen, 518110 China**

Prepared by

Guangdong Global Testing Technology Co., Ltd.

**Room 101-105, 203-210, Building 1, No.2, Keji 8 Road, Songshan Lake Park,
Dongguan city, Guangdong, People's Republic of China, 523808**

This report is based on a single evaluation of the submitted sample(s) of the above mentioned product, it does not imply an assessment of the production of the products.

This report shall not be reproduced, except in full, without the written approval of Guangdong Global Testing Technology Co., Ltd.

Revision History

Rev.	Issue Date	Revisions	Revised By
V0	September 6, 2024	Initial Issue	

Summary of Test Results

Test Item	Clause	Limit/Requirement	Result
Antenna Requirement	N/A	FCC Part 15.203/15.247 (c)	Compliance
AC Power Line Conducted Emission	ANSI C63.10-2013, Clause 6.2	FCC Part 15.207	Pass
Conducted Output Power	ANSI C63.10-2013, Clause 11.9.1.3	FCC Part 15.247 (b)(3)	Pass
6dB Bandwidth	ANSI C63.10-2013, Clause 11.8.1	FCC Part 15.247 (a)(2)	Pass
Power Spectral Density	ANSI C63.10-2013, Clause 11.10.2	FCC Part 15.247 (e)	Pass
Conducted Band edge and spurious emission	ANSI C63.10-2013, Clause 11.11	FCC Part 15.247(d)	Pass
Radiated Band edge and Spurious Emission	ANSI C63.10-2013, Clause 11.11 & Clause 11.12	FCC Part 15.205/15.209	Pass
Duty Cycle	ANSI C63.10-2013, Clause 11.6	None; for reporting purposes only.	Pass

*This test report is only published to and used by the applicant, and it is not for evidence purpose in China.

*The measurement result for the sample received is <Pass> according to <CFR 47 FCC PART 15 SUBPART C(DTS)> when <Accuracy Method> decision rule is applied.

CONTENTS

1.	ATTESTATION OF TEST RESULTS	5
2.	TEST METHODOLOGY	6
3.	FACILITIES AND ACCREDITATION	6
4.	CALIBRATION AND UNCERTAINTY	7
4.1.	<i>MEASURING INSTRUMENT CALIBRATION</i>	7
4.2.	<i>MEASUREMENT UNCERTAINTY</i>	7
5.	EQUIPMENT UNDER TEST	8
5.1.	<i>DESCRIPTION OF EUT</i>	8
5.2.	<i>CHANNEL LIST</i>	8
5.3.	<i>MAXIMUM EIRP</i>	9
5.4.	<i>TEST CHANNEL CONFIGURATION</i>	9
5.5.	<i>THE WORSE CASE POWER SETTING PARAMETER</i>	9
5.6.	<i>DESCRIPTION OF AVAILABLE ANTENNAS</i>	9
5.7.	<i>EUT ACCESSORY</i>	9
5.8.	<i>SUPPORT UNITS FOR SYSTEM TEST</i>	10
5.9.	<i>SETUP DIAGRAM</i>	10
6.	MEASURING EQUIPMENT AND SOFTWARE USED	11
7.	ANTENNA PORT TEST RESULTS	13
7.1.	<i>Conducted Output Power</i>	13
7.2.	<i>6dB Bandwidth</i>	14
7.3.	<i>Power Spectral Density</i>	15
7.4.	<i>Conducted Band edge and spurious emission</i>	16
7.5.	<i>Duty Cycle</i>	18
8.	RADIATED TEST RESULTS	19
8.1.	<i>Radiated Band edge and Spurious Emission</i>	24
9.	ANTENNA REQUIREMENT	36
10.	AC POWER LINE CONDUCTED EMISSION	37
11.	TEST DATA - Appendix A	40
	APPENDIX: PHOTOGRAPHS OF TEST CONFIGURATION	57
	APPENDIX: PHOTOGRAPHS OF THE EUT	58

1. ATTESTATION OF TEST RESULTS

Applicant Information

Company Name: SHENZHEN JIUHU TECHNOLOGY CO., LTD
 Address: 4F, HE Sheng Teng Tech Industrial Park, HuanGuan South Road.10 Guanlan, LongHua, ShenZhen, 518110 China

Manufacturer Information

Company Name: SHENZHEN JIUHU TECHNOLOGY CO., LTD
 Address: 4F, HE Sheng Teng Tech Industrial Park, HuanGuan South Road.10 Guanlan, LongHua, ShenZhen, 518110 China

EUT Information

Product Description: Headset screen
 Model: JH-ANC930PLUS Screen
 Series Model: /
 Brand: /
 Sample Received Date: August 20, 2024
 Sample Status: Normal
 Sample ID: A24080217 001
 Date of Tested: August 20, 2024 to September 6, 2024

APPLICABLE STANDARDS	
STANDARD	TEST RESULTS
CFR 47 FCC PART 15 SUBPART C(DTS)	Pass

Prepared By:

Win Huang

Win Huang

Project Engineer

Checked By:

Alan He

Alan He

Laboratory Leader

Approved By:

Shawn Wen

Shawn Wen

Laboratory Manager



2. TEST METHODOLOGY

All tests were performed in accordance with the standard CFR 47 FCC PART 15 SUBPART C(DTS)

3. FACILITIES AND ACCREDITATION

Accreditation Certificate	<p>A2LA (Certificate No.: 6947.01) Guangdong Global Testing Technology Co., Ltd. has been assessed and proved to be in compliance with A2LA.</p> <p>FCC (FCC Designation No.: CN1343) Guangdong Global Testing Technology Co., Ltd. has been recognized to perform compliance testing on equipment subject to Supplier's Declaration of Conformity (SDoC) and Certification rules</p> <p>ISED (Company No.: 30714) Guangdong Global Testing Technology Co., Ltd. has been registered and fully described in a report filed with ISED. The Company Number is 30714 and the test lab Conformity Assessment Body Identifier (CABID) is CN0148.</p>
---------------------------	--

Note: All tests measurement facilities use to collect the measurement data are located at Room 101-105, 203-210, Building 1, No.2, Keji 8 Road, Songshan Lake Park, Dongguan city, Guangdong, People's Republic of China, 523808

4. CALIBRATION AND UNCERTAINTY

4.1. MEASURING INSTRUMENT CALIBRATION

The measuring equipment utilized to perform the tests documented in this report has been calibrated in accordance with the manufacturer's recommendations and is traceable to recognized national standards.

4.2. MEASUREMENT UNCERTAINTY

Where relevant, the following measurement uncertainty levels have been estimated for tests performed on the apparatus:

Test Items	k	Uncertainty
DTS Bandwidth	1.96	±9.2 PPM
20dB Emission Bandwidth	1.96	±9.2 PPM
Carrier Frequency Separation	1.96	±9.2 PPM
Time of Occupancy	1.96	±0.57%
Conducted Output Power	1.96	±1.5 dB
Power Spectral Density Level	1.96	±1.9 dB
Conducted Spurious Emission	1.96	9 kHz-30 MHz: ± 0.95 dB 30 MHz-1 GHz: ± 1.5 dB 1GHz-12.75GHz: ± 1.8 dB 12.75 GHz-26.5 GHz: ± 2.1dB

Note: This uncertainty represents an expanded uncertainty expressed at approximately the 95% confidence level using a coverage factor of k=1.96.

Test Item	Measurement Frequency Range	K	U(dB)
Conducted emissions from the AC mains power ports (AMN)	150 kHz ~ 30 MHz	2	3.37
Radiated emissions	9 kHz ~ 30 MHz	2	4.16
Radiated emissions	30 MHz ~ 1 GHz	2	3.79
Radiated emissions	1 GHz ~ 18 GHz	2	5.62
Radiated emissions	18 GHz ~ 40 GHz	2	5.54

Note: This uncertainty represents an expanded uncertainty expressed at approximately the 95% confidence level using a coverage factor of k=2.

5. EQUIPMENT UNDER TEST

5.1. DESCRIPTION OF EUT

EUT Name		Headset screen
Model		JH-ANC930PLUS Screen
Series Model		/
Model Difference		/
Hardware Version		V1.0
Software Version		V1.0
Ratings		DC 5V 1A
Power Supply	DC	5V
	Battery	DC 3.7V 200mAh

Frequency Band:	2400 MHz to 2483.5 MHz
Frequency Range:	2402 MHz to 2480 MHz
Bluetooth Version:	Bluetooth V5.4
Bluetooth Mode:	Bluetooth LE
Type of Modulation:	GFSK
Number of Channels:	40
Channel Separation:	2 MHz
Maximum Peak Power:	0.58 dBm
Antenna Type:	Chip Antenna
Antenna Gain:	2.67 dBi
Normal Test Voltage:	3.7 Vdc
EUT Test software:	FCC_assist_1.0.2.2
Note:	The Antenna Gain was provided by customer, and this information may affect the validity of the results, customer should be responsible for this.

5.2. CHANNEL LIST

Channel	Frequency (MHz)	Channel	Frequency (MHz)	Channel	Frequency (MHz)	Channel	Frequency (MHz)
0	2402	11	2424	22	2446	33	2468
1	2404	12	2426	23	2448	34	2470
2	2406	13	2428	24	2450	35	2472
3	2408	14	2430	25	2452	36	2474
4	2410	15	2432	26	2454	37	2476
5	2412	16	2434	27	2456	38	2478
6	2414	17	2436	28	2458	39	2480
7	2416	18	2438	29	2460	/	/
8	2418	19	2440	30	2462	/	/

9	2420	20	2442	31	2464	/	/
10	2422	21	2444	32	2468	/	/

5.3. MAXIMUM EIRP

Test Mode	Frequency (MHz)	Channel Number	Maximum Peak Output Power (dBm)	Maximum EIRP (dBm)
BLE 1Mbps	2402 ~ 2480	0-39[40]	0.58	/

5.4. TEST CHANNEL CONFIGURATION

Test Mode	Test Channel	Frequency
BLE 1Mbps	CH 0(Low Channel), CH 19(MID Channel), CH 39(High Channel)	2402 MHz, 2440 MHz, 2480 MHz

5.5. THE WORSE CASE POWER SETTING PARAMETER

The Worse Case Power Setting Parameter under 2400 ~ 2483.5MHz Band				
Test Software Version		FCC_assist_1.0.2.2		
Modulation Type	Transmit Antenna Number	Test Software setting value		
		CH 0	CH 19	CH 39
BLE 1Mbps	1	10	10	10

5.6. DESCRIPTION OF AVAILABLE ANTENNAS

Antenna	Frequency (MHz)	Antenna Type	MAX Antenna Gain (dBi)
1	2402-2480	Chip	2.67

Test Mode	Transmit and Receive Mode	Description
BLE Mbps	<input checked="" type="checkbox"/> 1TX, 1RX	Antenna 1 can be used as transmitting/receiving antenna.
Note:		

5.7. EUT ACCESSORY

Cable	
Accessory:	USB cable
Model No.:	/
Description:	USB Type-C Plug Cable
Cable Type:	Unshielded without ferrite; Unshielded with two ferrite

Length:	0.53 Meter
---------	------------

5.8. SUPPORT UNITS FOR SYSTEM TEST

The following support units or accessories were used to form a representative test configuration during the tests.

Item	Equipment	Mfr/Brand	Model/Type No.	Series No.	Note
E-1	Laptop	Lenovo	Thinkpad T14	PF-3EAKYR	GTG Support
E-2	Adapter	Xiaomi	MDY-11-EX	N/A	GTG Support

5.9. SETUP DIAGRAM

Radiated emissions:



AC Power Line Conducted Emission:

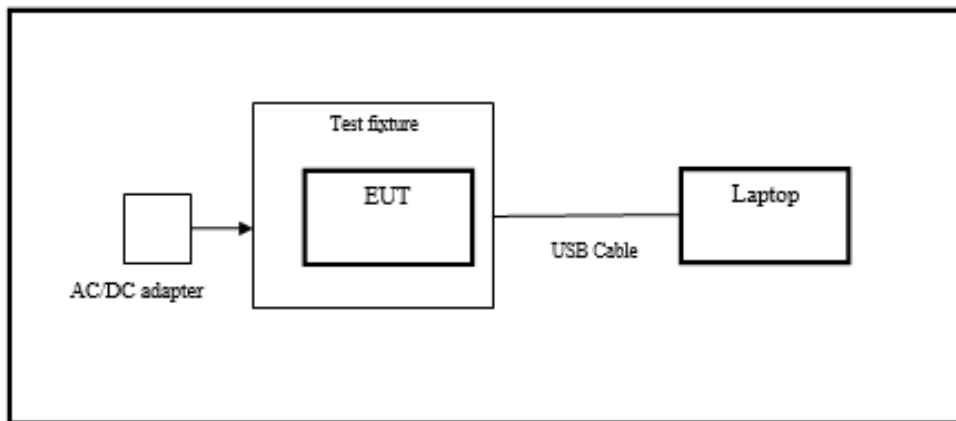

6. MEASURING EQUIPMENT AND SOFTWARE USED

Test Equipment of Conducted RF					
Equipment	Manufacturer	Model No.	Serial No.	Last Cal.	Due Date
Spectrum Analyzer	Rohde & Schwarz	FSV40	102257	2023/09/18	2024/09/17
Spectrum Analyzer	KEYSIGHT	N9020A	MY51285127	2023/09/18	2024/09/17
EXG Analog Signal Generator	KEYSIGHT	N5173B	MY61253075	2023/09/18	2024/09/17
Vector Signal Generator	Rohde & Schwarz	SMM100A	101899	2023/09/18	2024/09/17
RF Control box	MWRF-test	MW100-RFCB	MW220926GTG	2023/09/18	2024/09/17
Wideband Radio Communication Tester	Rohde & Schwarz	CMW270	102792	2023/09/18	2024/09/17
Wideband Radio Communication Tester	Rohde & Schwarz	CMW500	103235	2023/09/18	2024/09/17
temperature humidity chamber	Espec	SH-241	SH-241-2014	2023/09/18	2024/09/17
RF Test Software	MWRF-test	MTS8310E (Ver. V2/0)	N/A	N/A	N/A

Test Equipment of Radiated emissions below 1GHz					
Equipment	Manufacturer	Model No.	Serial No.	Last Cal.	Due Date
3m Semi-anechoic Chamber	ETS	9m*6m*6m	Q2146	2022/08/30	2025/08/29
EMI Test Receiver	Rohde & Schwarz	ESCI3	101409	2023/09/18	2024/09/17
Spectrum Analyzer	KEYSIGHT	N9020A	MY51283932	2023/09/18	2024/09/17
Pre-Amplifier	HZEMC	HPA-9K0130	HYP A21001	2023/09/18	2024/09/17
Biconilog Antenna	Schwarzbeck	VULB 9168	01315	2022/10/10	2025/10/09
Biconilog Antenna	ETS	3142E	00243646	2022/03/23	2025/03/22
Loop Antenna	ETS	6502	243668	2022/03/30	2025/03/29
Test Software	Farad	EZ-EMC (Ver.FA-03A2 RE)	N/A	N/A	N/A

Test Equipment of Radiated emissions above 1GHz					
Equipment	Manufacturer	Model No.	Serial No.	Last Cal.	Due Date
3m Semi-anechoic Chamber	ETS	9m*6m*6m	Q2149	2022/08/30	2025/08/29
Spectrum Analyzer	Rohde & Schwarz	FSV40	101413	2023/09/18	2024/09/17
Spectrum Analyzer	KEYSIGHT	N9020A	MY51283932	2023/09/18	2024/09/17
Pre-Amplifier	A-INFO	HPA-1G1850	HYP A21003	2023/09/18	2024/09/17
Horn antenna	A-INFO	3117	246069	2022/03/11	2025/03/10
Pre-Amplifier	ZKJC	HPA-184057	HYP A21004	2023/09/18	2024/09/17

Horn antenna	ZKJC	3116C	246265	2022/03/29	2025/03/28
Test Software	Farad	EZ-EMC (Ver.FA-03A2 RE+)	N/A	N/A	N/A

Test Equipment of Conducted emissions					
Equipment	Manufacturer	Model No.	Serial No.	Last Cal.	Due Date
Shielded Room	CHENG YU	8m*5m*4m	N/A	2022/10/29	2025/10/28
EMI Test Receiver	Rohde & Schwarz	ESR3	102647	2023/09/18	2024/09/17
LISN/AMN	Rohde & Schwarz	ENV216	102843	2023/09/18	2024/09/17
NNLK 8129 RC	Schwarzbeck	NNLK 8129 RC	5046	2023/09/18	2024/09/17
Test Software	Farad	EZ-EMC (Ver. EMC-con-3A1 1+)	N/A	N/A	N/A

7. ANTENNA PORT TEST RESULTS

7.1. CONDUCTED OUTPUT POWER

LIMITS

CFR 47 FCC Part15 (15.247) Subpart C			
Section	Test Item	Limit	Frequency Range (MHz)
CFR 47 FCC 15.247(b)(3) ISED RSS-247 5.4 (d)	Peak Conduct Output Power	1 watt or 30 dBm	2400-2483.5

TEST PROCEDURE

Connect the EUT to a low loss RF cable from the antenna port to the power sensor (video bandwidth is greater than the occupied bandwidth).

Measure peak emission level, the indicated level is the peak output power, after any corrections for external attenuators and cables.

TEST SETUP

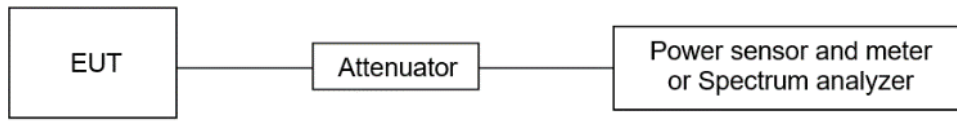

TEST ENVIRONMENT

Temperature	22.5°C	Relative Humidity	53%
Atmosphere Pressure	100kPa		

TEST RESULTS

Please refer to section "Test Data" - Appendix A

7.2. 6DB BANDWIDTH

LIMITS

CFR 47 FCC Part15 (15.247) Subpart C			
Section	Test Item	Limit	Frequency Range (MHz)
CFR 47 FCC 15.247(a)(2)	6 dB Bandwidth	≥ 500 kHz	2400-2483.5

TEST PROCEDURE

Refer to ANSI C63.10-2013 clause 11.8 for DTS bandwidth and clause 6.9 for Occupied Bandwidth.

Connect the EUT to the spectrum analyser and use the following settings:

Center Frequency	The center frequency of the channel under test
Frequency Span	For 6 dB Bandwidth: Enough to capture all products of the modulation carrier emission
Detector	Peak
RBW	For 6 dB Bandwidth: 100 kHz
VBW	For 6 dB Bandwidth: $\geq 3 \times$ RBW
Trace	Max hold
Sweep	Auto couple

a) Allow the trace to stabilize and measure the maximum width of the emission that is constrained by the frequencies associated with the two outermost amplitude points (upper and lower frequencies) that are attenuated by 6 dB relative to the maximum level measured in the fundamental emission.

TEST SETUP

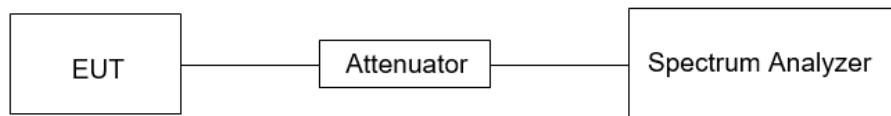

TEST ENVIRONMENT

Temperature	22.5°C	Relative Humidity	53%
Atmosphere Pressure	100kPa		

TEST RESULTS

Please refer to section "Test Data" - Appendix A

7.3. POWER SPECTRAL DENSITY

LIMITS

CFR 47 FCC Part15 (15.247) Subpart C			
Section	Test Item	Limit	Frequency Range (MHz)
CFR 47 FCC §15.247 (e)	Power Spectral Density	8 dBm in any 3 kHz band	2400-2483.5

TEST PROCEDURE

Refer to ANSI C63.10-2013 clause 11.10.

Connect the EUT to the spectrum analyser and use the following settings:

Center Frequency	The center frequency of the channel under test
Detector	PEAK
RBW	$3 \text{ kHz} \leq \text{RBW} \leq 100 \text{ kHz}$
VBW	$\geq 3 \times \text{RBW}$
Span	1.5 x DTS bandwidth
Trace	Max hold
Sweep time	Auto couple

Allow trace to fully stabilize and use the peak marker function to determine the maximum amplitude level within the RBW.

If measured value exceeds limit, reduce RBW (no less than 3 kHz) and repeat.

TEST SETUP

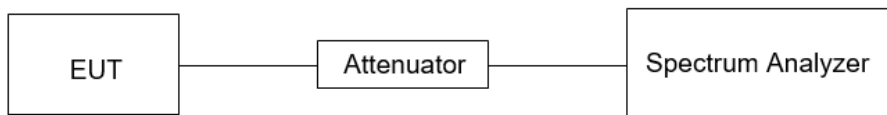

TEST ENVIRONMENT

Temperature	22.5°C	Relative Humidity	53%
Atmosphere Pressure	100kPa		

TEST RESULTS

Please refer to section "Test Data" - Appendix A

7.4. CONDUCTED BAND EDGE AND SPURIOUS EMISSION

LIMITS

CFR 47 FCC Part15 (15.247) Subpart C		
Section	Test Item	Limit
CFR 47 FCC §15.247 (d)	Conducted Bandedge and Spurious Emissions	at least 20 dB below that in the 100 kHz bandwidth within the band that contains the highest level of the desired power

TEST PROCEDURE

Refer to ANSI C63.10-2013 clause 11.11 and 11.13.

Connect the EUT to the spectrum analyser and use the following settings for reference level measurement:

Center Frequency	The center frequency of the channel under test
Detector	Peak
RBW	100 kHz
VBW	$\geq 3 \times \text{RBW}$
Span	1.5 x DTS bandwidth
Trace	Max hold
Sweep time	Auto couple.

Allow trace to fully stabilize and use the peak marker function to determine the maximum PSD level.

Change the settings for emission level measurement:

Span	Set the center frequency and span to encompass frequency range to be measured
Detector	Peak
RBW	100 kHz
VBW	$\geq 3 \times \text{RBW}$
measurement points	$\geq \text{span}/\text{RBW}$
Trace	Max hold
Sweep time	Auto couple.

Allow trace to fully stabilize and use the peak marker function to determine the maximum PSD level. Ensure that the amplitude of all unwanted emissions outside of the authorized frequency band (excluding restricted frequency bands) is attenuated by at least the minimum requirements specified in 11.11.

TEST SETUP

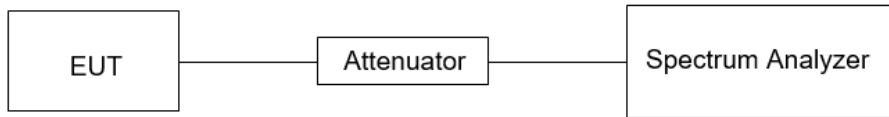

TEST ENVIRONMENT

Temperature	22.5°C	Relative Humidity	53%
Atmosphere Pressure	100kPa		

TEST RESULTS

Please refer to section "Test Data" - Appendix A

7.5. DUTY CYCLE

LIMITS

None; for reporting purposes only.

TEST PROCEDURE

Refer to ANSI C63.10-2013 clause 11.6 Zero – Span Spectrum Analyzer method.

TEST SETUP

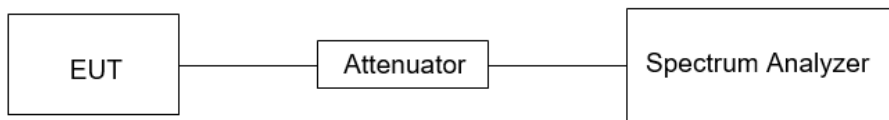

TEST ENVIRONMENT

Temperature	22.5°C	Relative Humidity	53%
Atmosphere Pressure	100kPa		

TEST RESULTS

Please refer to section "Test Data" - Appendix A

8. RADIATED TEST RESULTS

LIMITS

Please refer to CFR 47 FCC §15.205 and §15.209.

Radiation Disturbance Test Limit for FCC (Class B) (9 kHz ~ 1 GHz)

Emissions radiated outside of the specified frequency bands above 30 MHz			
Frequency Range (MHz)	Field Strength Limit (uV/m) at 3 m	Field Strength Limit (dBuV/m) at 3 m	
		Quasi-Peak	
30 - 88	100	40	
88 - 216	150	43.5	
216 - 960	200	46	
Above 960	500	54	
Above 1000	500	Peak	Average
		74	54

FCC Emissions radiated outside of the specified frequency bands below 30 MHz		
Frequency (MHz)	Field strength (microvolts/meter)	Measurement distance (meters)
0.009-0.490	2400/F(kHz)	300
0.490-1.705	24000/F(kHz)	30
1.705-30.0	30	30

FCC Restricted bands of operation refer to FCC §15.205 (a):

MHz	MHz	MHz	GHz
0.090-0.110	16.42-16.423	399.9-410	4.5-5.15
¹ 0.495-0.505	16.69475-16.69525	608-614	5.35-5.46
2.1735-2.1905	16.80425-16.80475	960-1240	7.25-7.75
4.125-4.128	25.5-25.67	1300-1427	8.025-8.5
4.17725-4.17775	37.5-38.25	1435-1626.5	9.0-9.2
4.20725-4.20775	73-74.6	1645.5-1646.5	9.3-9.5
6.215-6.218	74.8-75.2	1660-1710	10.6-12.7
6.26775-6.26825	108-121.94	1718.8-1722.2	13.25-13.4
6.31175-6.31225	123-138	2200-2300	14.47-14.5
8.291-8.294	149.9-150.05	2310-2390	15.35-16.2
8.362-8.366	156.52475-156.52525	2483.5-2500	17.7-21.4
8.37625-8.38675	156.7-156.9	2690-2900	22.01-23.12
8.41425-8.41475	162.0125-167.17	3260-3267	23.6-24.0
12.29-12.293	167.72-173.2	3332-3339	31.2-31.8
12.51975-12.52025	240-285	3345.8-3358	36.43-36.5
12.57675-12.57725	322-335.4	3600-4400	(²)
13.36-13.41			

Note: ¹Until February 1, 1999, this restricted band shall be 0.490-0.510 MHz.

²Above 38.6c

TEST PROCEDURE

Below 30 MHz

The setting of the spectrum analyser

RBW	200 Hz (From 9 kHz to 0.15 MHz)/ 9 kHz (From 0.15 MHz to 30 MHz)
VBW	200 Hz (From 9 kHz to 0.15 MHz)/ 9 kHz (From 0.15 MHz to 30 MHz)
Sweep	Auto

1. The testing follows the guidelines in ANSI C63.10-2013 clause 6.4.
2. The EUT was arranged to its worst case and then turntable (from 0 degree to 360 degrees) to find the maximum reading. A pre-amp and a high pass filter are used for the test in order to get better signal level. Both Horizontal, Face-on and Face-off polarizations of the antenna are set to make the measurement.
3. The EUT was placed on a turntable with 80 cm above ground.
4. The EUT was set 3 meters from the interference receiving antenna, which was mounted on the top of a 1 m height antenna tower.
5. The radiated emission limits are based on measurements employing a CISPR quasi-peak detector except for the frequency bands 9-90 kHz, 110-490 kHz and above 1000 MHz Radiated emission limits in these three bands are based on measurements employing an average detector.
6. For measurement below 1 GHz, the initial step in collecting conducted emission data is a spectrum analyzer peak detector mode pre-scanning the measurement frequency range. Significant peaks are then marked and then Quasi Peak and average detector mode re-measured. If the emission level of the EUT measured by the peak detector is 3 dB lower than the applicable limit, the peak emission level will be reported. Otherwise, the emission measurement will be repeated using the quasi-peak and average detector and reported.
7. Although these tests were performed other than open field site, adequate comparison measurements were confirmed against 30m open field site. Therefore sufficient tests were made to demonstrate that the alternative site produces results that correlate with the ones of tests made in an open field site based on KDB 414788.
8. The limits in CFR 47, Part 15, Subpart C, paragraph 15.209 (a), are identical to those in RSS-GEN Section 8.9, Table 6, since the measurements are performed in terms of magnetic field strength and converted to electric field strength levels (as reported in the table) using the free space impedance of 377Ω. For example, the measurement frequency X KHz resulted in a level of Y dBuV/m, which is equivalent to $Y-51.5 = Z$ dBuA/m, which has the same margin, W dB, to the corresponding RSS-GEN Table 6 limit as it has to be 15.209(a) limit.

Below 1 GHz and above 30 MHz

The setting of the spectrum analyser

RBW	120 kHz
VBW	300 kHz
Sweep	Auto
Detector	Peak/QP
Trace	Max hold

1. The testing follows the guidelines in ANSI C63.10-2013 clause 6.5.

2. The EUT was arranged to its worst case and then tune the antenna tower (from 1 m to 4 m) and turntable (from 0 degree to 360 degrees) to find the maximum reading. A pre-amp and a high pass filter are used for the test in order to get better signal level. Both horizontal and vertical polarizations of the antenna are set to make the measurement.
3. The EUT was placed on a turntable with 80 cm above ground.
4. The EUT was set 3 meters from the interference receiving antenna, which was mounted on the top of a variable height antenna tower.
5. For measurement below 1 GHz, the initial step in collecting conducted emission data is a spectrum analyzer peak detector mode pre-scanning the measurement frequency range. Significant peaks are then marked and then Quasi Peak detector mode re-measured. If the emission level of the EUT measured by the peak detector is 3 dB lower than the applicable limit, the peak emission level will be reported. Otherwise, the emission measurement will be repeated using the quasi-peak detector and reported.

Above 1G

The setting of the spectrum analyser

RBW	1 MHz
VBW	PEAK: 3 MHz AVG: see note 6
Sweep	Auto
Detector	Peak
Trace	Max hold

1. The testing follows the guidelines in ANSI C63.10-2013 clause 6.6.
2. The EUT was arranged to its worst case and then tune the antenna tower (from 1 m to 4 m) and turntable (from 0 degree to 360 degrees) to find the maximum reading. A pre-amp and a high pass filter are used for the test in order to get better signal level. Both horizontal and vertical polarizations of the antenna are set to make the measurement.
3. The EUT was placed on a turntable with 1.5 m above ground.
4. The EUT was set 3 meters from the interference receiving antenna, which was mounted on the top of a variable height antenna tower.
5. For measurement above 1 GHz, the emission measurement will be measured by the peak detector. This peak level, once corrected, must comply with the limit specified in Section 15.209.
6. For measurements above 1 GHz the resolution bandwidth is set to 1 MHz, then the video bandwidth is set to 3 MHz for peak measurements and 1 MHz resolution bandwidth with 1/T video bandwidth with peak detector for average measurements. For the Duty Cycle please refer to clause 7.1.ON TIME AND DUTY CYCLE.

X axis, Y axis, Z axis positions:

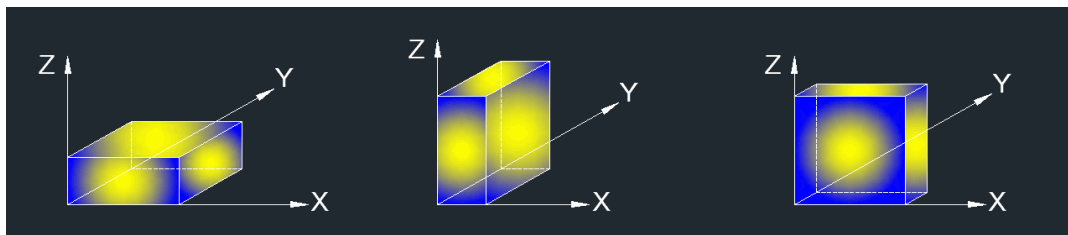

Note 1: For all radiated test, EUT in each of three orthogonal axis emissions had been tested, but only the worst case (X axis) data recorded in the report.

TEST SETUP

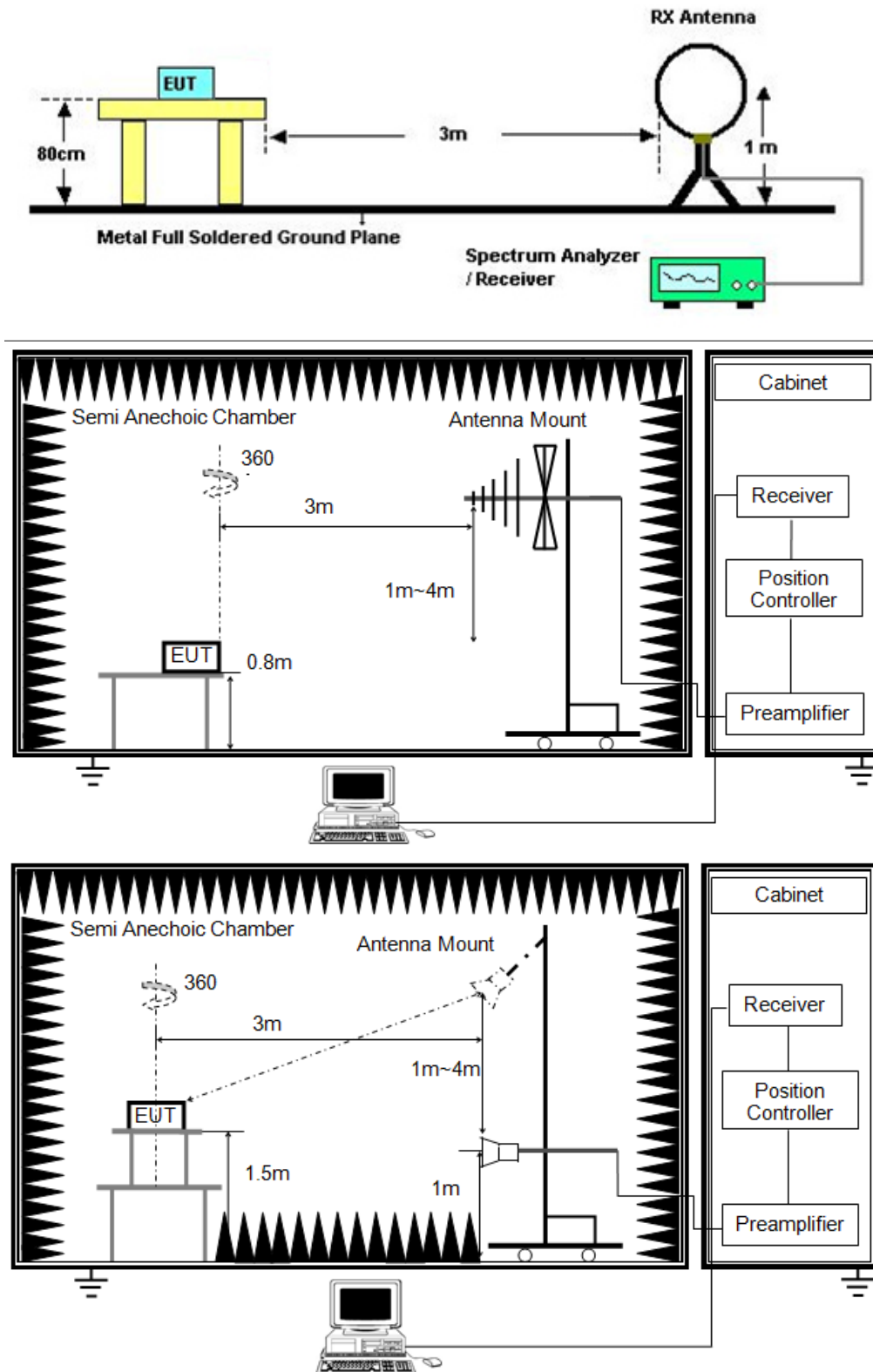

TEST ENVIRONMENT

Temperature	23.2°C	Relative Humidity	53%
Atmosphere Pressure	101kPa		

TEST RESULTS

8.1. RADIATED BAND EDGE AND SPURIOUS EMISSION

- 30MHz to 1GHz

The worst result as bellow:

Mode:	BLE1M-2402
Power:	DC 5V
TE:	Big
Date	2024/9/02
T/A/P	23.2°C/53%/101Kpa

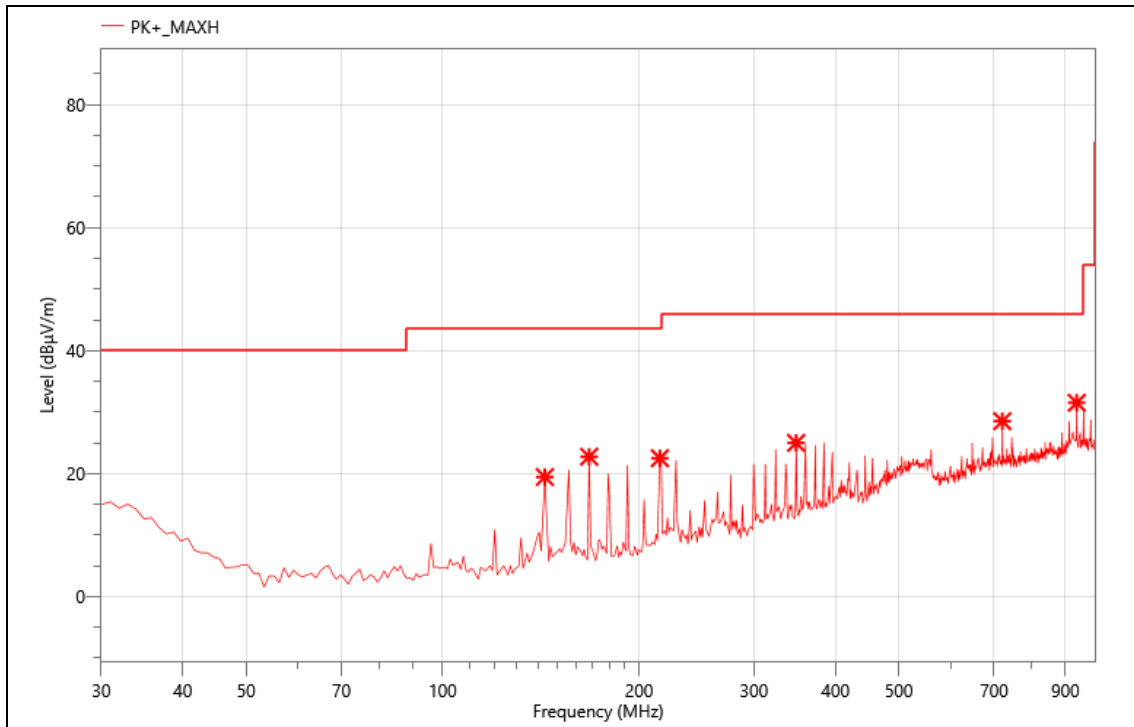

Critical_Freqs

No.	Freq. (MHz)	Reading (dBµV)	Corr. (dB)	Meas. (dBµV/m)	Limit (dBµV/m)	Margin (dB)	Det.	Pol.
1	143.490	42.96	-23.52	19.44	43.50	24.06	PK+	V
2	167.740	45.44	-22.7	22.74	43.50	20.76	PK+	V
3	215.270	43.50	-21	22.50	43.50	21.00	PK+	V
4	348.160	41.50	-16.51	24.99	46.00	21.01	PK+	V
5	720.640	35.46	-6.94	28.52	46.00	17.48	PK+	V
6	936.950	34.69	-3.17	31.52	46.00	14.48	PK+	V

Note: [Margin=Limit-Meas.]; [Meas.=Reading+Corr.]

Mode:	BLE1M-2402
Power:	DC 5V
TE:	Big
Date	2024/9/02
T/A/P	23.2°C/53%/101Kpa

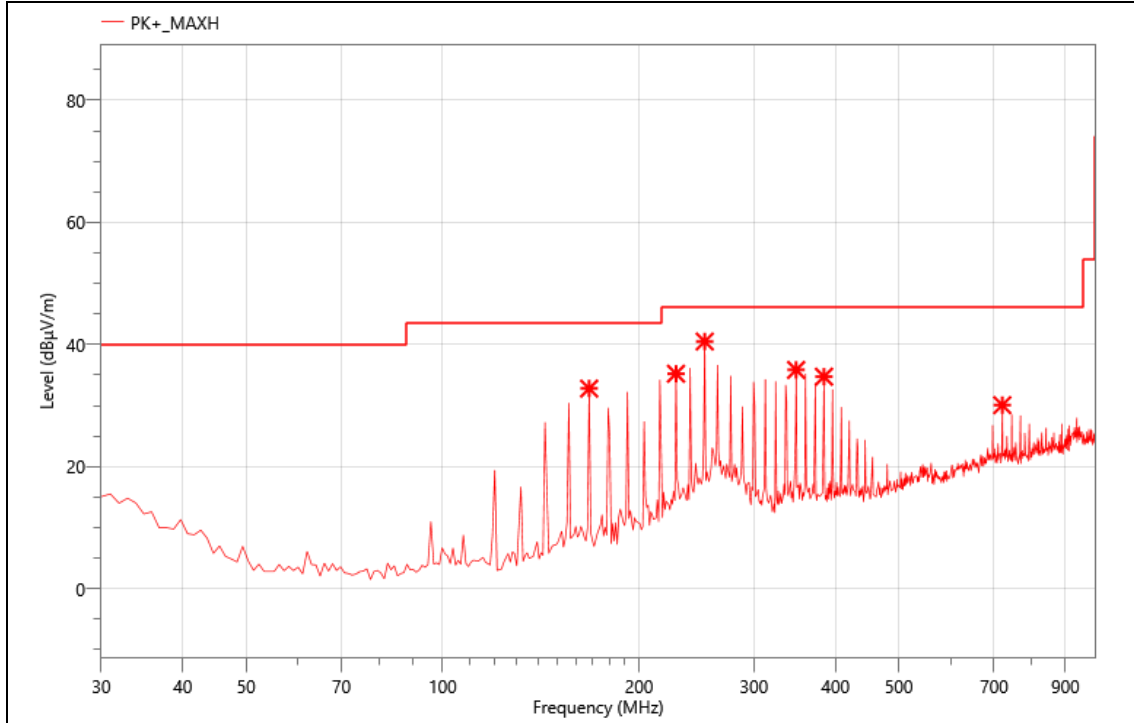

Critical_Freqs

No.	Freq. (MHz)	Reading (dBµV)	Corr. (dB)	Meas. (dBµV/m)	Limit (dBµV/m)	Margin (dB)	Det.	Pol.
1	167.740	55.49	-22.7	32.79	43.50	10.71	PK+	H
2	227.880	55.61	-20.4	35.21	46.00	10.79	PK+	H
3	252.130	59.48	-18.99	40.49	46.00	5.51	PK+	H
4	348.160	52.35	-16.51	35.84	46.00	10.16	PK+	H
5	384.050	49.41	-14.68	34.73	46.00	11.27	PK+	H
6	720.640	37.01	-6.94	30.07	46.00	15.93	PK+	H

Note: [Margin=Limit-Meas.]; [Meas.=Reading+Corr.]

- Above 1GHz

The worst result as bellow:

Mode:	BLE1M-2402
Power:	DC 5V
TE:	Big
Date	2024/9/02
T/A/P	23.2°C/53%/101Kpa

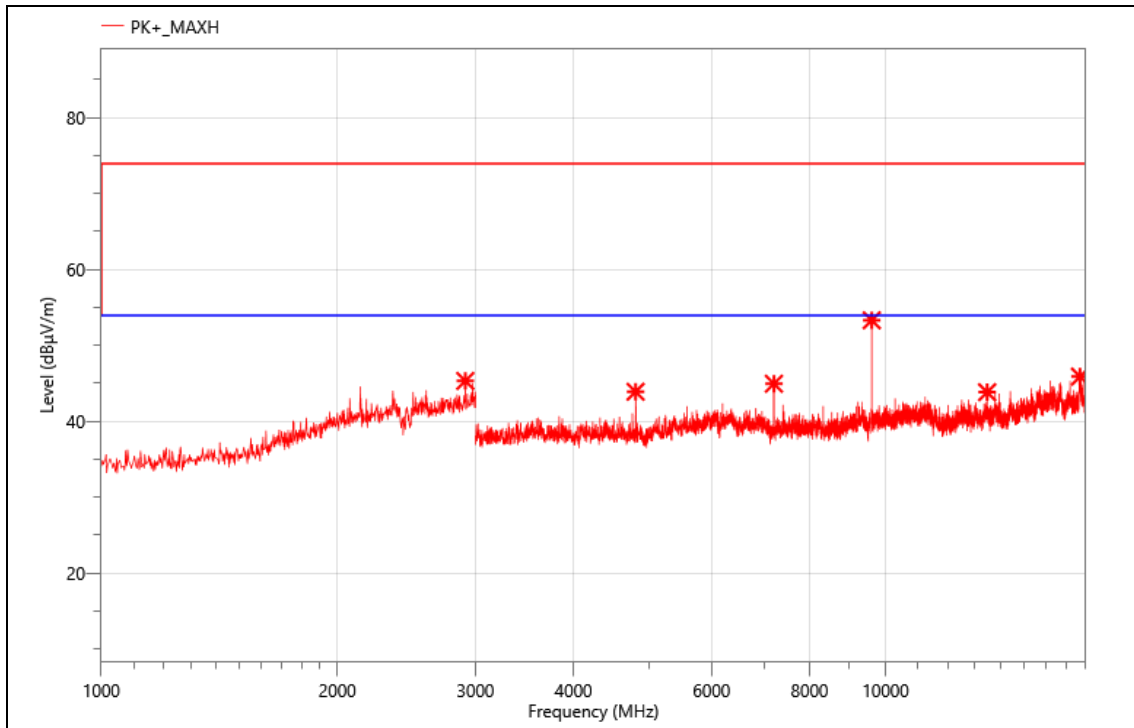

Critical_Freqs

No.	Freq. (MHz)	Reading (dBµV)	Corr. (dB)	Meas. (dBµV/m)	Limit (dBµV/m)	Margin (dB)	Det.	Pol.
1	2912.000	52.99	-7.67	45.32	74.00	28.68	PK+	H
2	4800.000	55.22	-11.32	43.90	74.00	30.10	PK+	H
3	7206.000	52.95	-8	44.95	74.00	29.05	PK+	H
4	9601.500	60.23	-6.92	53.31	74.00	20.69	PK+	H
5	13476.000	48.25	-4.41	43.84	74.00	30.16	PK+	H
6	17700.000	45.72	0.18	45.90	74.00	28.10	PK+	H

Note: [Margin=Limit-Meas.]; [Meas.=Reading+Corr.]

Mode:	BLE1M-2402
Power:	DC 5V
TE:	Big
Date	2024/9/02
T/A/P	23.2°C/53%/101Kpa

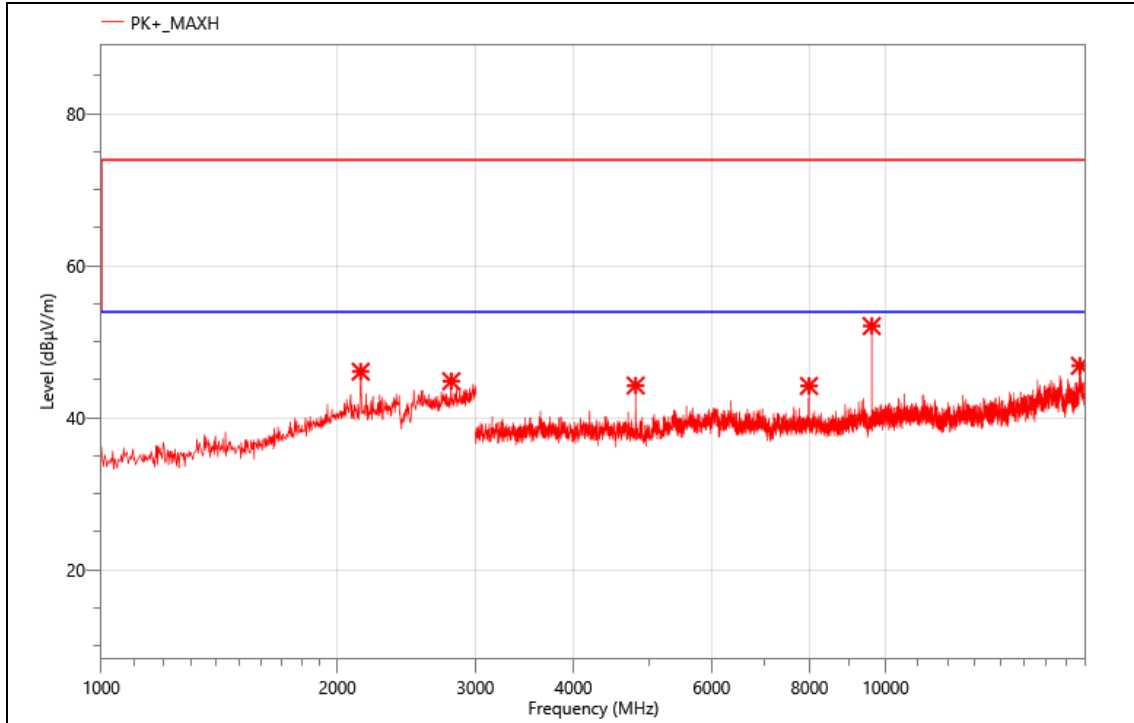

Critical_Freqs

No.	Freq. (MHz)	Reading (dBµV)	Corr. (dB)	Meas. (dBµV/m)	Limit (dBµV/m)	Margin (dB)	Det.	Pol.
1	2142.000	55.13	-9.05	46.08	74.00	27.92	PK+	V
2	2794.000	53.23	-8.41	44.82	74.00	29.18	PK+	V
3	4801.500	55.59	-11.33	44.26	74.00	29.74	PK+	V
4	7986.000	52.26	-8.05	44.21	74.00	29.79	PK+	V
5	9601.500	59.00	-6.92	52.08	74.00	21.92	PK+	V
6	17695.500	46.64	0.21	46.85	74.00	27.15	PK+	V

Note: [Margin=Limit-Meas.]; [Meas.=Reading+Corr.]

Mode:	BLE1M-2440
Power:	DC 5V
TE:	Big
Date	2024/9/02
T/A/P	23.2°C/53%/101Kpa

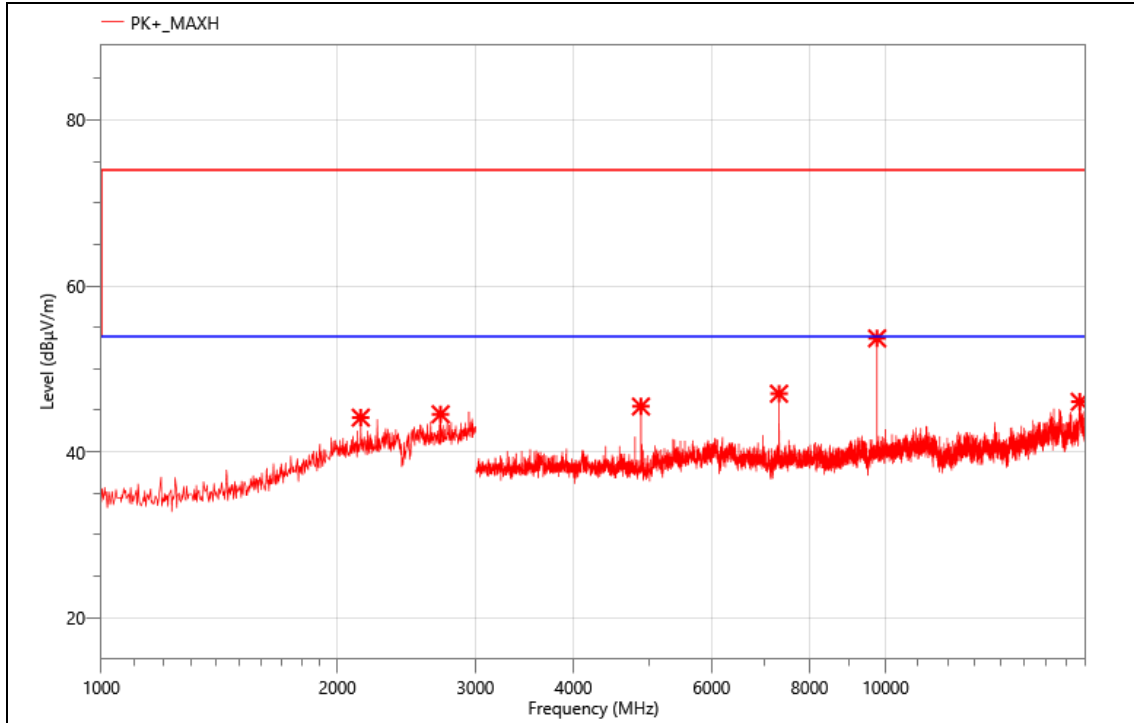

Critical_Freqs

No.	Freq. (MHz)	Reading (dBµV)	Corr. (dB)	Meas. (dBµV/m)	Limit (dBµV/m)	Margin (dB)	Det.	Pol.
1	2142.000	53.16	-9.05	44.11	74.00	29.89	PK+	H
2	2708.000	52.98	-8.46	44.52	74.00	29.48	PK+	H
3	4876.500	56.61	-11.15	45.46	74.00	28.54	PK+	H
4	7314.000	54.69	-7.69	47.00	74.00	27.00	PK+	H
5	9754.500	60.42	-6.75	53.67	74.00	20.33	PK+	H
6	17686.500	45.78	0.25	46.03	74.00	27.97	PK+	H

Note: [Margin=Limit-Meas.]; [Meas.=Reading+Corr.]

Mode:	BLE1M-2440
Power:	DC 5V
TE:	Big
Date	2024/9/02
T/A/P	23.2°C/53%/101Kpa

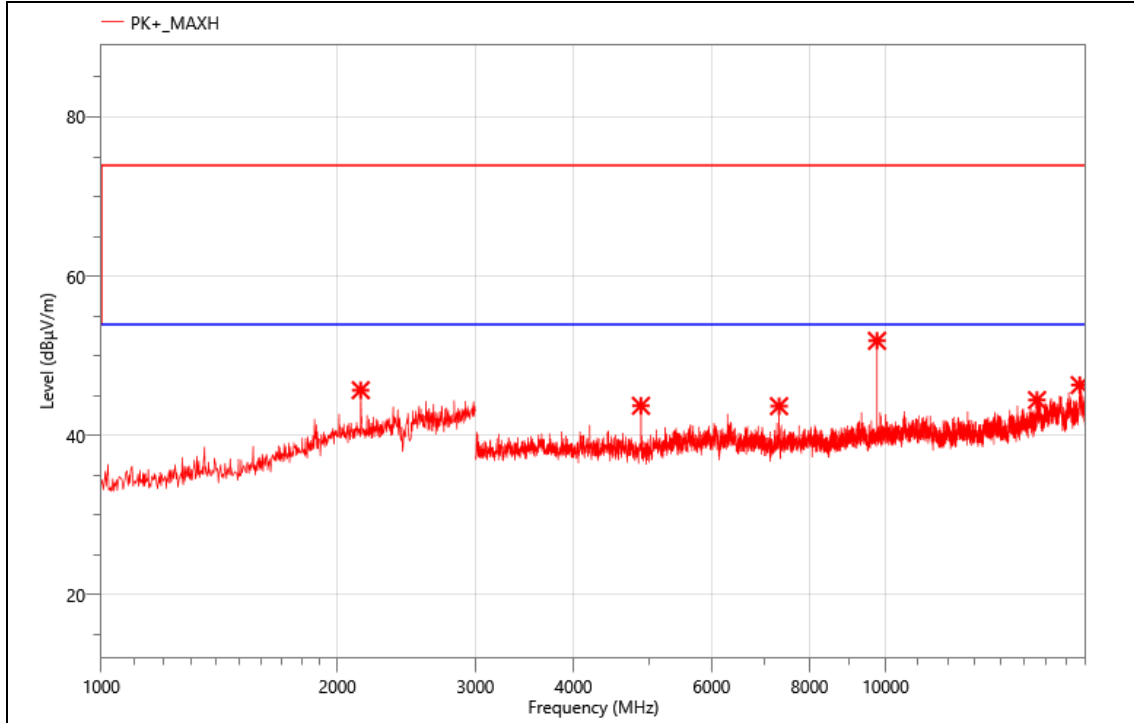

Critical_Freqs

No.	Freq. (MHz)	Reading (dBµV)	Corr. (dB)	Meas. (dBµV/m)	Limit (dBµV/m)	Margin (dB)	Det.	Pol.
1	2142.000	54.75	-9.05	45.70	74.00	28.30	PK+	V
2	4876.500	54.89	-11.15	43.74	74.00	30.26	PK+	V
3	7314.000	51.38	-7.69	43.69	74.00	30.31	PK+	V
4	9753.000	58.61	-6.71	51.90	74.00	22.10	PK+	V
5	15598.500	47.33	-2.87	44.46	74.00	29.54	PK+	V
6	17682.000	46.06	0.28	46.34	74.00	27.66	PK+	V

Note: [Margin=Limit-Meas.]; [Meas.=Reading+Corr.]

Mode:	BLE1M-2480
Power:	DC 5V
TE:	Big
Date	2024/9/02
T/A/P	23.2°C/53%/101Kpa

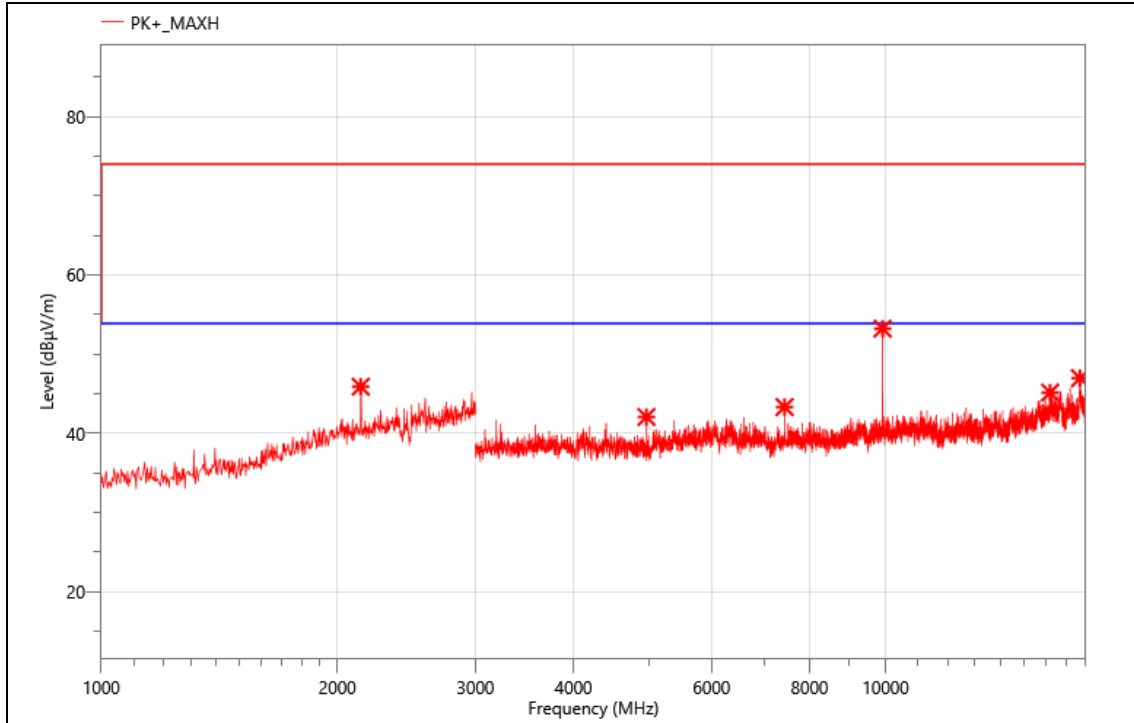

Critical_Freqs

No.	Freq. (MHz)	Reading (dBµV)	Corr. (dB)	Meas. (dBµV/m)	Limit (dBµV/m)	Margin (dB)	Det.	Pol.
1	2142.000	54.95	-9.05	45.90	74.00	28.10	PK+	V
2	4956.000	53.44	-11.37	42.07	74.00	31.93	PK+	V
3	7434.000	51.22	-7.9	43.32	74.00	30.68	PK+	V
4	9913.500	59.60	-6.37	53.23	74.00	20.77	PK+	V
5	16210.500	46.37	-1.21	45.16	74.00	28.84	PK+	V
6	17700.000	46.80	0.18	46.98	74.00	27.02	PK+	V

Note: [Margin=Limit-Meas.]; [Meas.=Reading+Corr.]

Mode:	BLE1M-2480
Power:	DC 5V
TE:	Big
Date	2024/9/02
T/A/P	23.2°C/53%/101Kpa

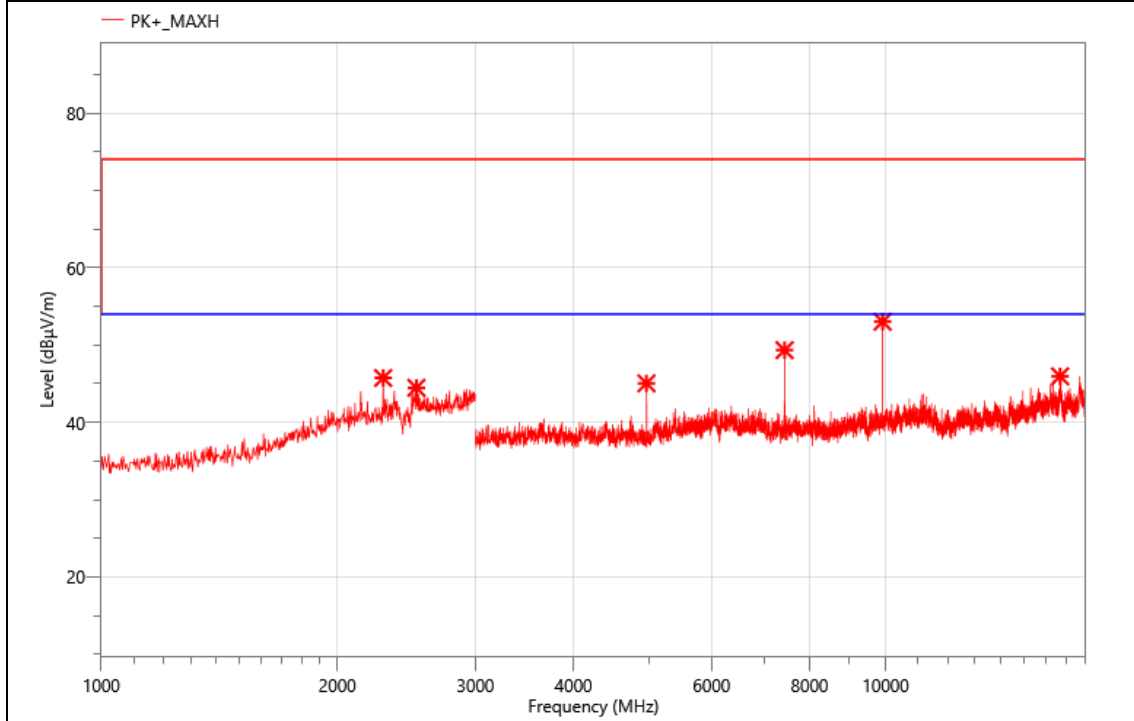

Critical_Freqs

No.	Freq. (MHz)	Reading (dBµV)	Corr. (dB)	Meas. (dBµV/m)	Limit (dBµV/m)	Margin (dB)	Det.	Pol.
1	2288.000	54.85	-9.1	45.75	74.00	28.25	PK+	H
2	2522.000	53.04	-8.57	44.47	74.00	29.53	PK+	H
3	4956.000	56.42	-11.37	45.05	74.00	28.95	PK+	H
4	7434.000	57.24	-7.9	49.34	74.00	24.66	PK+	H
5	9913.500	59.39	-6.37	53.02	74.00	20.98	PK+	H
6	16692.000	46.45	-0.49	45.96	74.00	28.04	PK+	H

Note: [Margin=Limit-Meas.]; [Meas.=Reading+Corr.]

Note:

1. Measurement = Reading Level + Correct Factor.
2. If Peak Result complies with AV limit, AV Result is deemed to comply with AV limit.
3. Peak: Peak detector.
4. Only the worst data was recorded, if it complies with the limit, the other emissions

deemed to comply with the limit.

For the frequency above 18 GHz, a pre-scan was performed, and the result was 20 dB lower than the limit line, the test data was not shown in the report.

● Band Edge

The worst result as bellow:

Mode:	BLE1M-2402
Power:	DC 5V
TE:	Big
Date	2024/9/02
T/A/P	23.2°C/53%/101Kpa

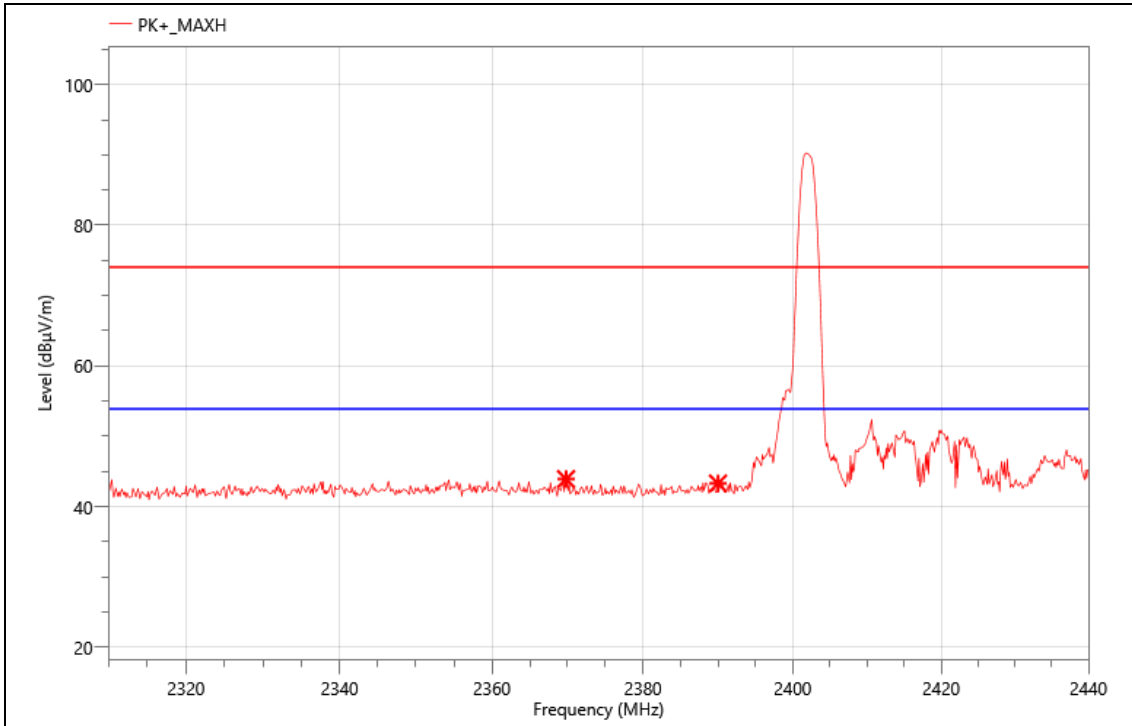

Critical_Freqs

No.	Freq. (MHz)	Reading (dBµV)	Corr. (dB)	Meas. (dBµV/m)	Limit (dBµV/m)	Margin (dB)	Det.	Pol.
1	2369.800	21.31	22.63	43.94	74.00	30.06	PK+	V
2	2390.000	20.59	22.72	43.31	74.00	30.69	PK+	V

Note: [Margin=Limit-Meas.]; [Meas.=Reading+Corr.]

Mode:	BLE1M-2402
Power:	DC 5V
TE:	Big
Date	2024/9/02
T/A/P	23.2°C/53%/101Kpa

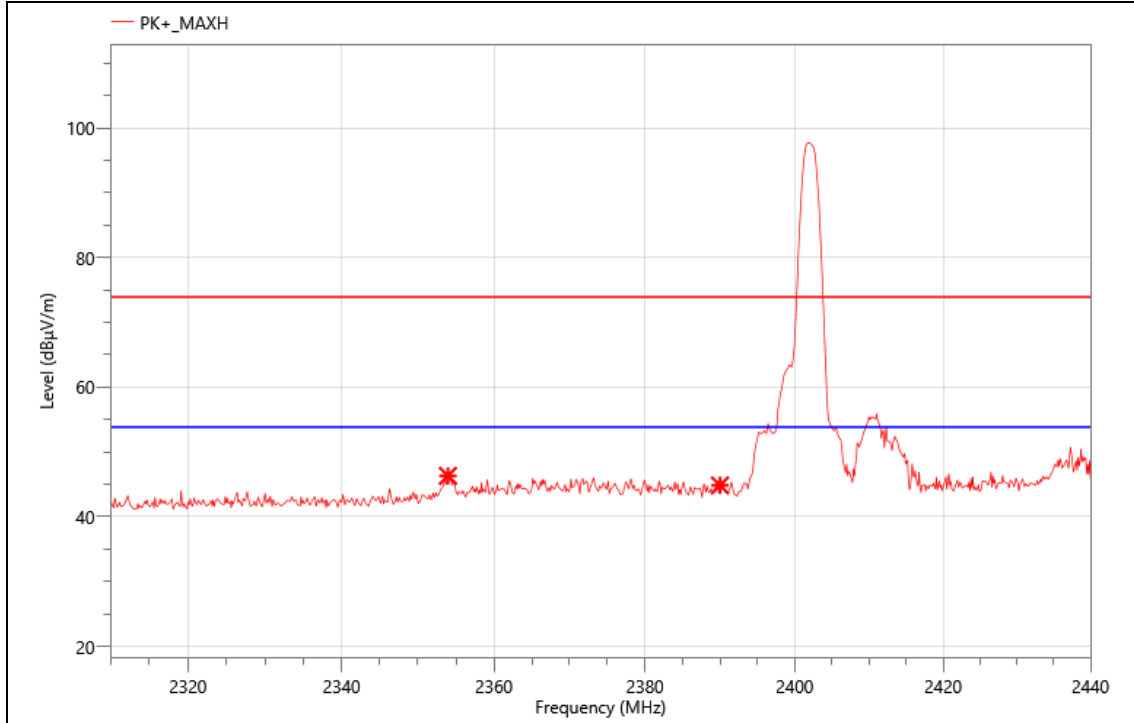

Critical_Freqs

No.	Freq. (MHz)	Reading (dBµV)	Corr. (dB)	Meas. (dBµV/m)	Limit (dBµV/m)	Margin (dB)	Det.	Pol.
1	2353.940	23.55	22.77	46.32	74.00	27.68	PK+	H
2	2390.000	22.14	22.72	44.86	74.00	29.14	PK+	H

Note: [Margin=Limit-Meas.]; [Meas.=Reading+Corr.]

Mode:	BLE1M-2480
Power:	DC 5V
TE:	Big
Date	2024/9/02
T/A/P	23.2°C/53%/101Kpa

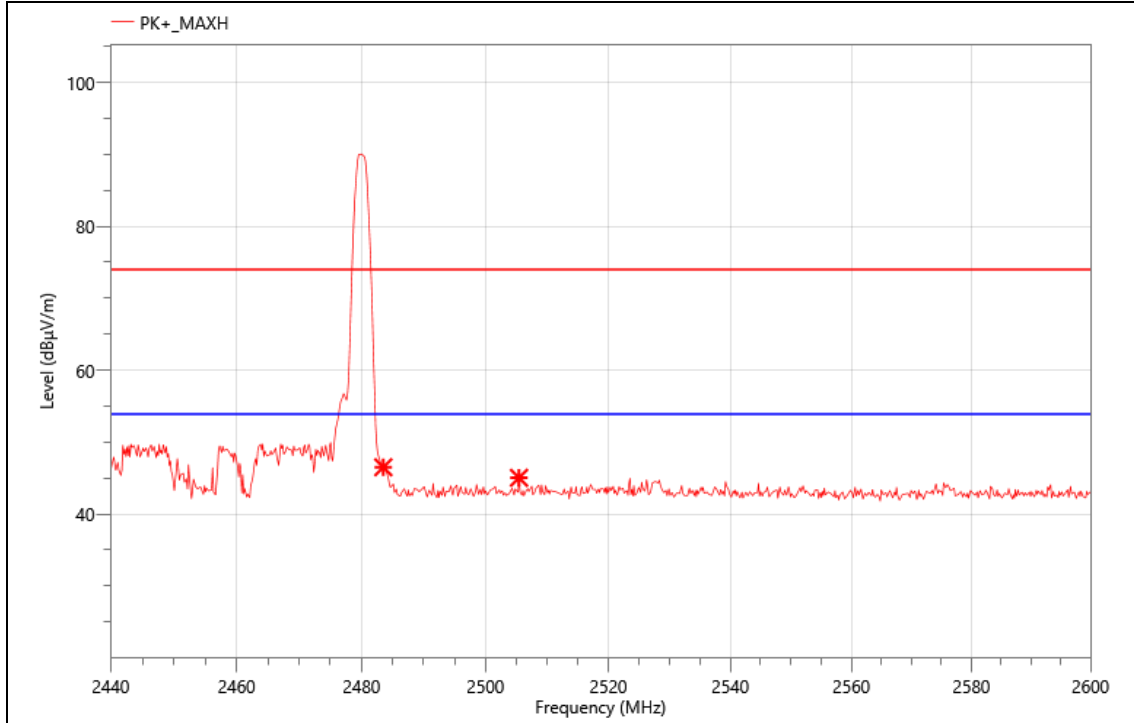

Critical_Freqs

No.	Freq. (MHz)	Reading (dBµV)	Corr. (dB)	Meas. (dBµV/m)	Limit (dBµV/m)	Margin (dB)	Det.	Pol.
1	2483.500	23.36	23.15	46.51	74.00	27.49	PK+	H
2	2505.440	21.95	23.1	45.05	74.00	28.95	PK+	H

Note: [Margin=Limit-Meas.]; [Meas.=Reading+Corr.]

Mode:	BLE1M-2480
Power:	DC 5V
TE:	Big
Date	2024/9/02
T/A/P	23.2°C/53%/101Kpa

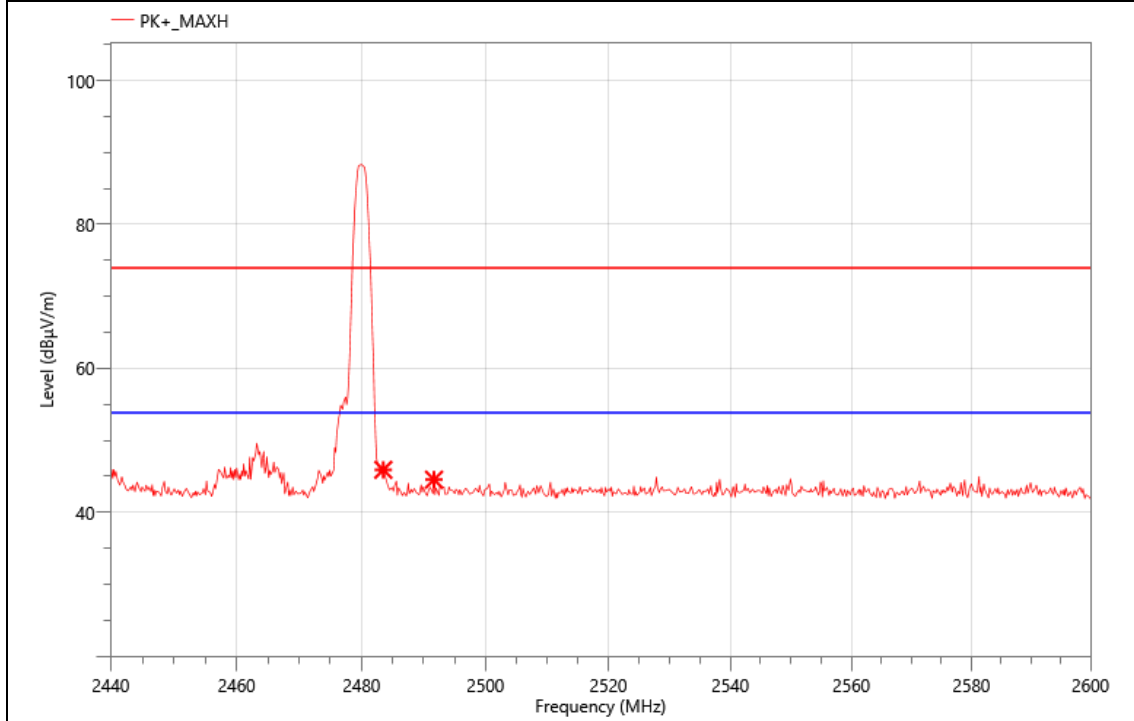

Critical_Freqs

No.	Freq. (MHz)	Reading (dBµV)	Corr. (dB)	Meas. (dBµV/m)	Limit (dBµV/m)	Margin (dB)	Det.	Pol.
1	2483.500	22.75	23.15	45.90	74.00	28.10	PK+	V
2	2491.680	21.41	23.13	44.54	74.00	29.46	PK+	V

Note: [Margin=Limit-Meas.]; [Meas.=Reading+Corr.]

9. ANTENNA REQUIREMENT

REQUIREMENT

Please refer to FCC §15.203

An intentional radiator shall be designed to ensure that no antenna other than that furnished by the responsible party shall be used with the device. The use of a permanently attached antenna or of an antenna that uses a unique coupling to the intentional radiator shall be considered sufficient to comply with the provisions of this section. The manufacturer may design the unit so that a broken antenna can be replaced by the user, but the use of a standard antenna jack or electrical connector is prohibited.

Please refer to FCC §15.247(b)(4)

The conducted output power limit specified in paragraph (b) of this section is based on the use of antennas with directional gains that do not exceed 6 dBi. Except as shown in paragraph (c) of this section, if transmitting antennas of directional gain greater than 6 dBi are used, the conducted output power from the intentional radiator shall be reduced below the stated values in paragraphs (b)(1), (b)(2), and (b)(3) of this section, as appropriate, by the amount in dB that the directional gain of the antenna exceeds 6 dBi.

DESCRIPTION

Compliance.

10. AC POWER LINE CONDUCTED EMISSION

LIMITS

Please refer to CFR 47 FCC §15.207 (a)

FREQUENCY (MHz)	Quasi-peak	Average
0.15 -0.5	66 - 56 *	56 - 46 *
0.50 -5.0	56.00	46.00
5.0 -30.0	60.00	50.00

TEST PROCEDURE

The EUT is put on a table of non-conducting material that is 80 cm high. The vertical conducting wall of shielding is located 40 cm to the rear of the EUT. The power line of the EUT is connected to the AC mains through a Artificial Mains Network (A.M.N.). A EMI Measurement Receiver (R&S Test Receiver ESR3) is used to test the emissions from both sides of AC line. According to the requirements in Section 6.2 of ANSI C63.10-2013. Conducted emissions from the EUT measured in the frequency range between 0.15 MHz and 30 MHz using CISPR Quasi-Peak and average detector mode. The bandwidth of EMI test receiver is set at 9 kHz.

The arrangement of the equipment is installed to meet the standards and operating in a manner, which tends to maximize its emission characteristics in a normal application.

TEST SETUP

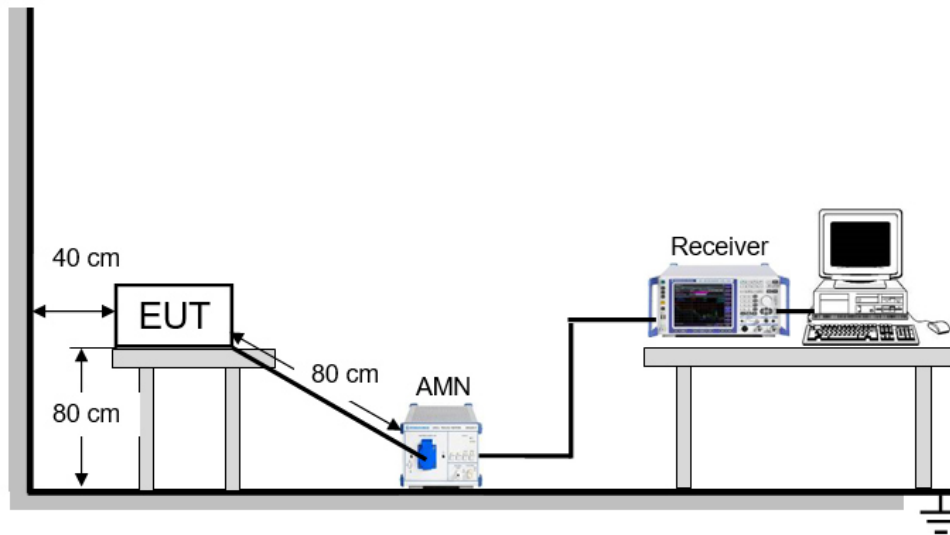

TEST ENVIRONMENT

Temperature	26°C	Relative Humidity	54%
Atmosphere Pressure	101kPa		

TEST RESULTS

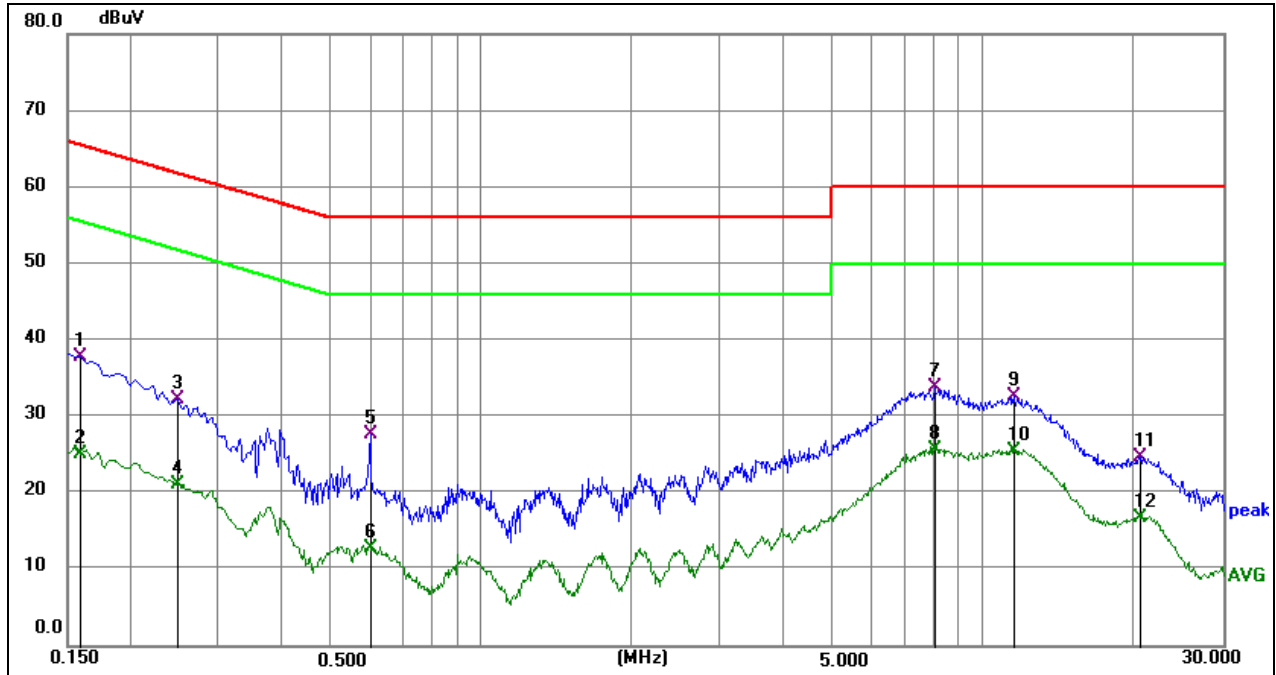

Phase: N	Mode: BLE 2402MHz
----------	-------------------

No.	Frequency (MHz)	Reading (dBuV)	Correct (dB)	Result (dBuV)	Limit (dBuV)	Margin (dB)	Remark
1	0.1590	27.93	9.90	37.83	65.52	-27.69	QP
2	0.1590	15.22	9.90	25.12	55.52	-30.40	AVG
3	0.2490	22.48	9.85	32.33	61.79	-29.46	QP
4	0.2490	11.21	9.85	21.06	51.79	-30.73	AVG
5	0.6000	17.81	9.86	27.67	56.00	-28.33	QP
6	0.6000	2.98	9.86	12.84	46.00	-33.16	AVG
7	8.0114	23.21	10.63	33.84	60.00	-26.16	QP
8	8.0114	15.07	10.63	25.70	50.00	-24.30	AVG
9	11.5530	20.97	11.59	32.56	60.00	-27.44	QP
10	11.5530	13.89	11.59	25.48	50.00	-24.52	AVG
11	20.5034	12.87	11.88	24.75	60.00	-35.25	QP
12	20.5034	4.85	11.88	16.73	50.00	-33.27	AVG

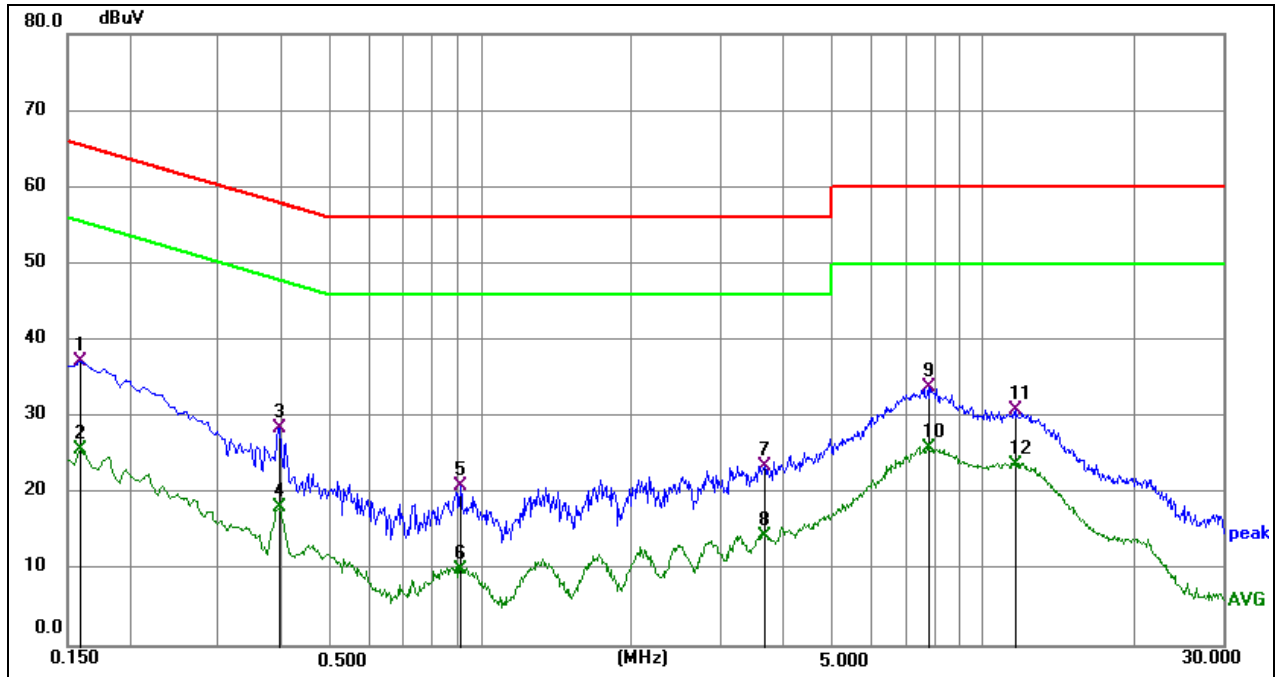

Phase: L1	Mode: BLE 2402MHz
-----------	-------------------

No.	Frequency (MHz)	Reading (dBuV)	Correct (dB)	Result (dBuV)	Limit (dBuV)	Margin (dB)	Remark
1	0.1590	27.43	9.84	37.27	65.52	-28.25	QP
2	0.1590	15.87	9.84	25.71	55.52	-29.81	AVG
3	0.3976	18.71	9.79	28.50	57.90	-29.40	QP
4	0.3976	8.33	9.79	18.12	47.90	-29.78	AVG
5	0.9087	11.05	9.82	20.87	56.00	-35.13	QP
6	0.9087	0.22	9.82	10.04	46.00	-35.96	AVG
7	3.6611	13.78	9.81	23.59	56.00	-32.41	QP
8	3.6611	4.65	9.81	14.46	46.00	-31.54	AVG
9	7.7689	24.01	9.77	33.78	60.00	-26.22	QP
10	7.7689	16.11	9.77	25.88	50.00	-24.12	AVG
11	11.6208	21.03	9.85	30.88	60.00	-29.12	QP
12	11.6208	13.87	9.85	23.72	50.00	-26.28	AVG

- Note: 1. Result = Reading + Correct Factor.
 2. If QP Result complies with AV limit, AV Result is deemed to comply with AV limit.
 3. Test setup: RBW: 200 Hz (9 kHz ~ 150 kHz), 9 kHz (150 kHz ~ 30 MHz).
 4. Step size: 80 Hz (0.009 MHz ~ 0.15 MHz), 4 kHz (0.15 MHz ~ 30 MHz), Scan time: auto.

Note: All the modes have been tested, only the worst data was recorded in the report.

11. TEST DATA - Appendix A

Duty Cycle

Condition	Mode	Frequency (MHz)	Antenna	On Time (ms)	Period (ms)	Duty Cycle (%)	Correction Factor (dB)	1/T (kHz)	Final settingFor VBW (kHz)
NVNT	BLE 1M	2402	Ant1	0	0	87.5	0.58	0	1
NVNT	BLE 1M	2440	Ant1	2.19	2.5	87.6	0.57	0.46	1
NVNT	BLE 1M	2480	Ant1	2.19	2.5	87.6	0.57	0.46	1

Maximum Conducted Output Power

Condition	Mode	Frequency (MHz)	Antenna	Conducted Power (dBm)	Duty Factor (dB)	Total Power (dBm)	Limit (dBm)	Verdict
NVNT	BLE 1M	2402	Ant1	0.41	0	0.41	30	Pass
NVNT	BLE 1M	2440	Ant1	0.58	0	0.58	30	Pass
NVNT	BLE 1M	2480	Ant1	0.55	0	0.55	30	Pass

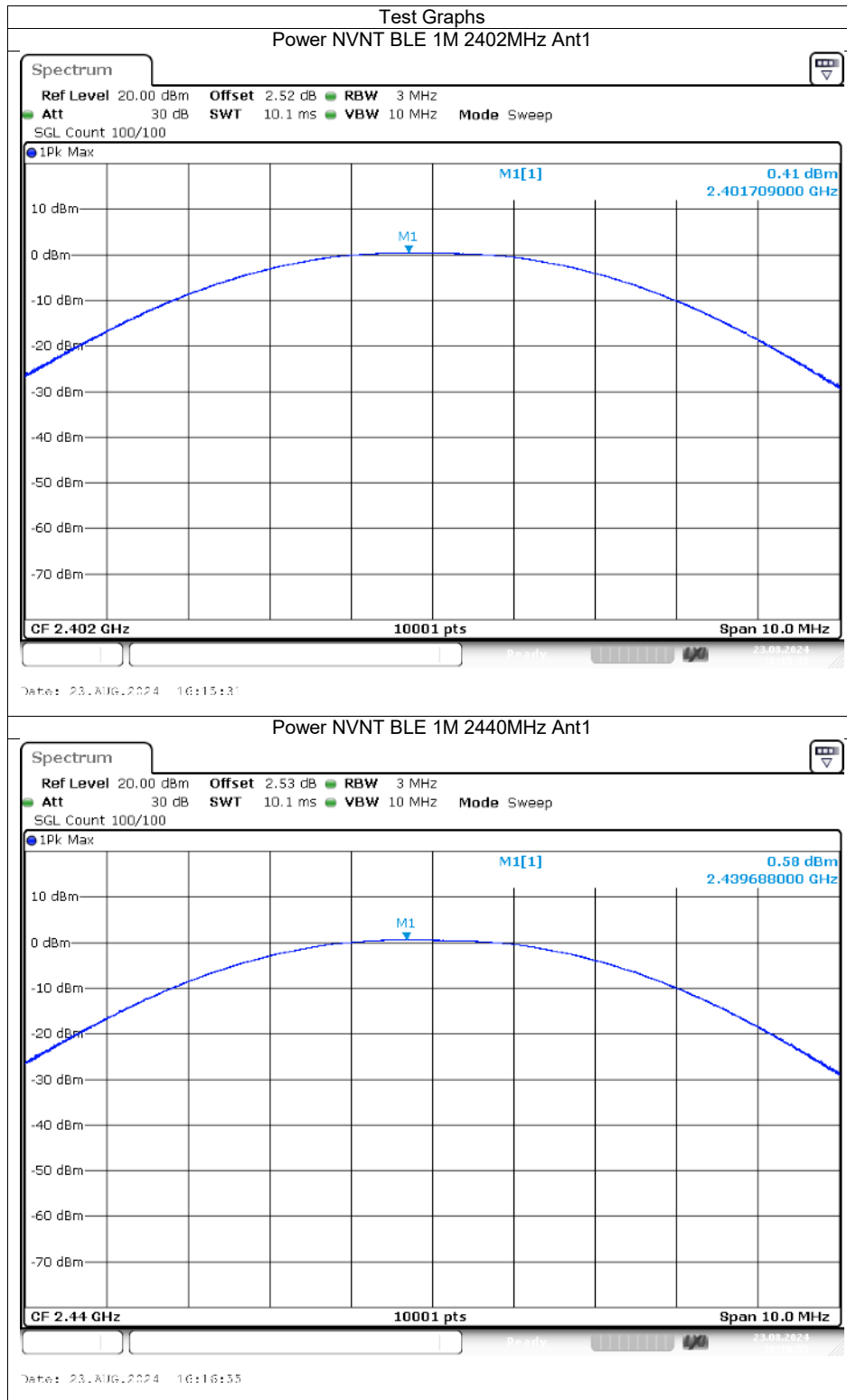

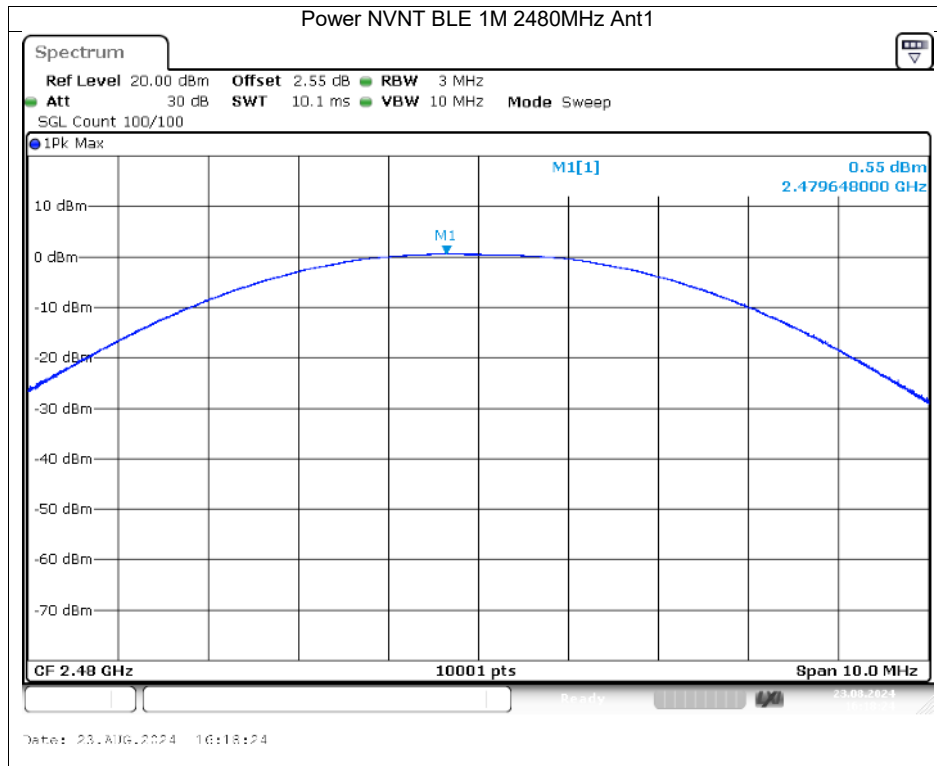

-6dB Bandwidth

Condition	Mode	Frequency (MHz)	Antenna	-6 dB Bandwidth (MHz)	Limit -6 dB Bandwidth (MHz)	Verdict
NVNT	BLE 1M	2402	Ant1	0.66	0.5	Pass
NVNT	BLE 1M	2440	Ant1	0.67	0.5	Pass
NVNT	BLE 1M	2480	Ant1	0.66	0.5	Pass

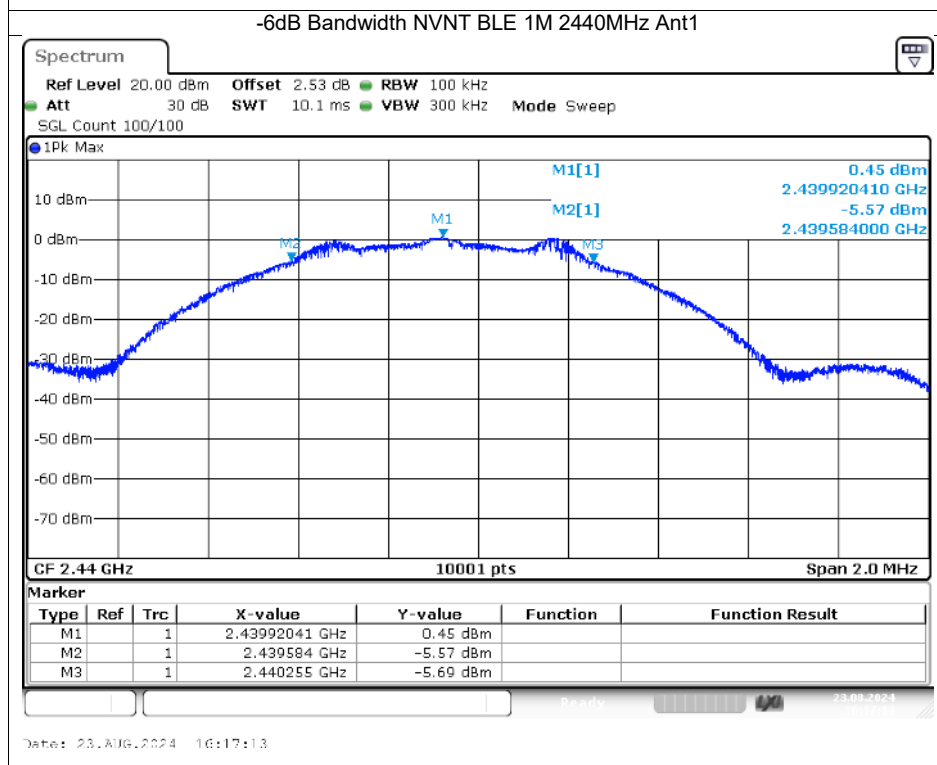
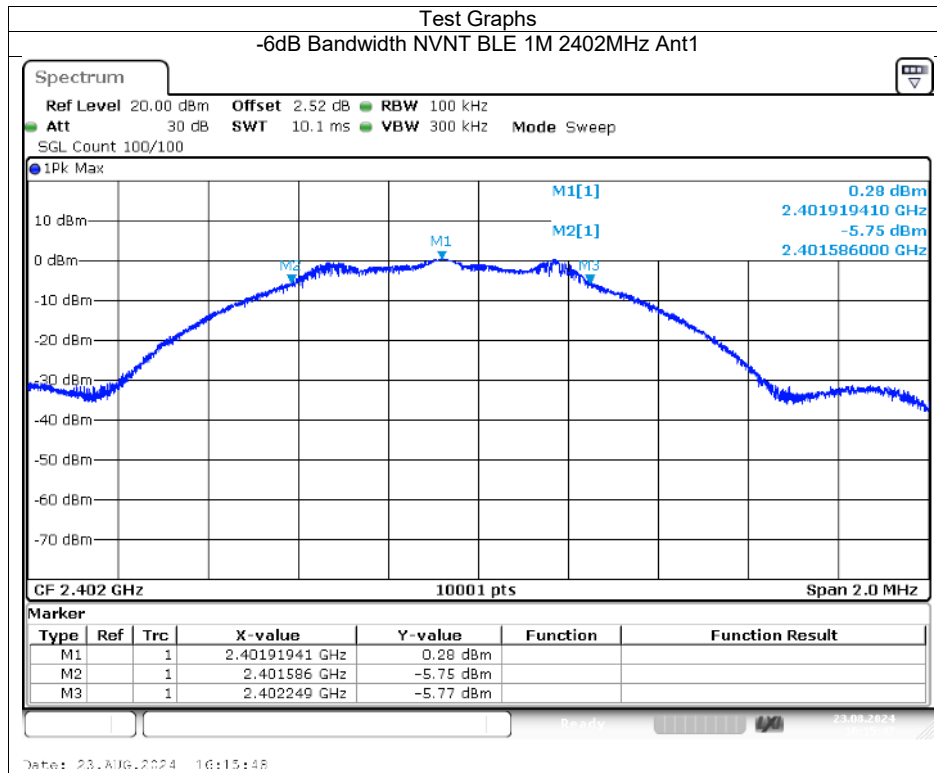

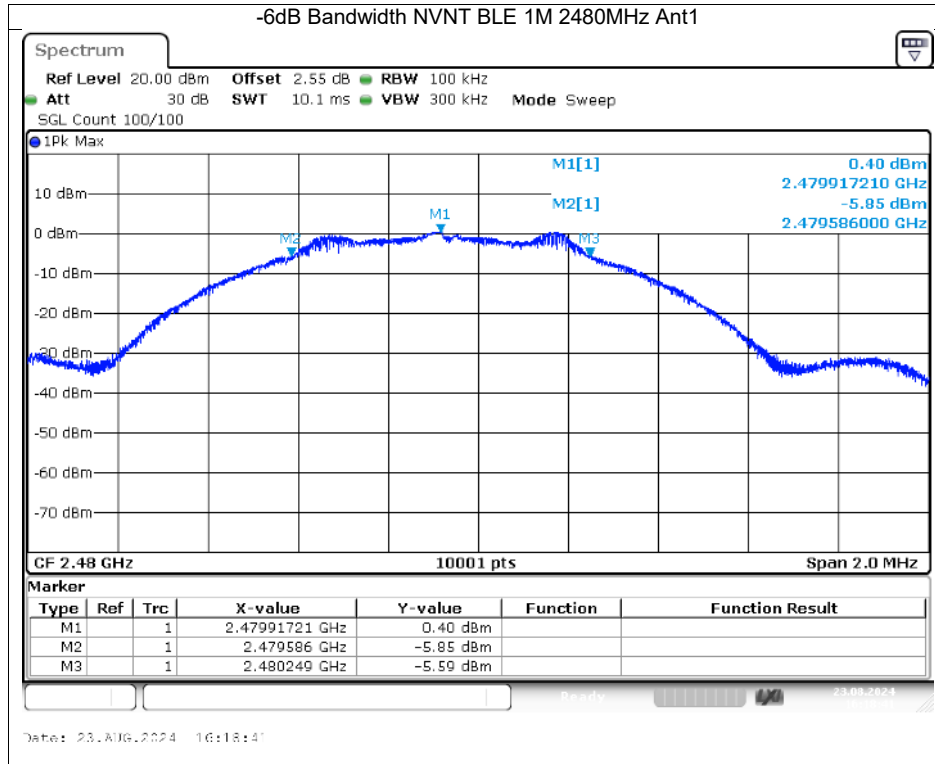

Maximum Power Spectral Density Level

Condition	Mode	Frequency (MHz)	Antenna	Conducted PSD (dBm/3kHz)	Duty Factor (dB)	Total PSD (dBm/3kHz)	Limit (dBm/3kHz)	Verdict
NVNT	BLE 1M	2402	Ant1	-10.46	0	-10.46	8	Pass
NVNT	BLE 1M	2440	Ant1	-12.83	0	-12.83	8	Pass
NVNT	BLE 1M	2480	Ant1	-11.14	0	-11.14	8	Pass

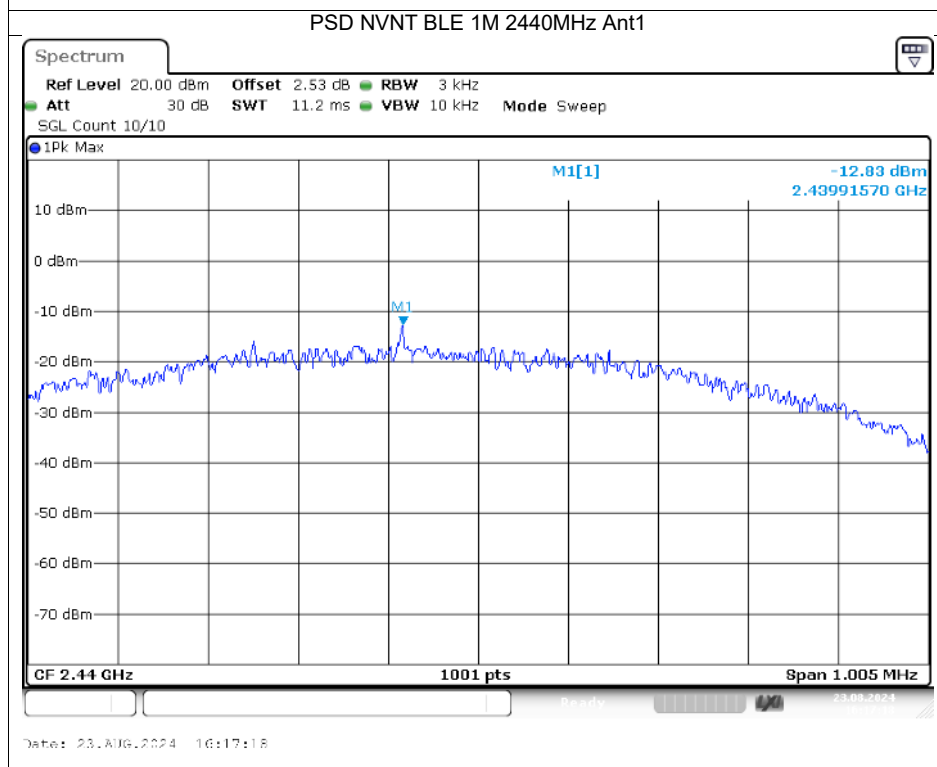
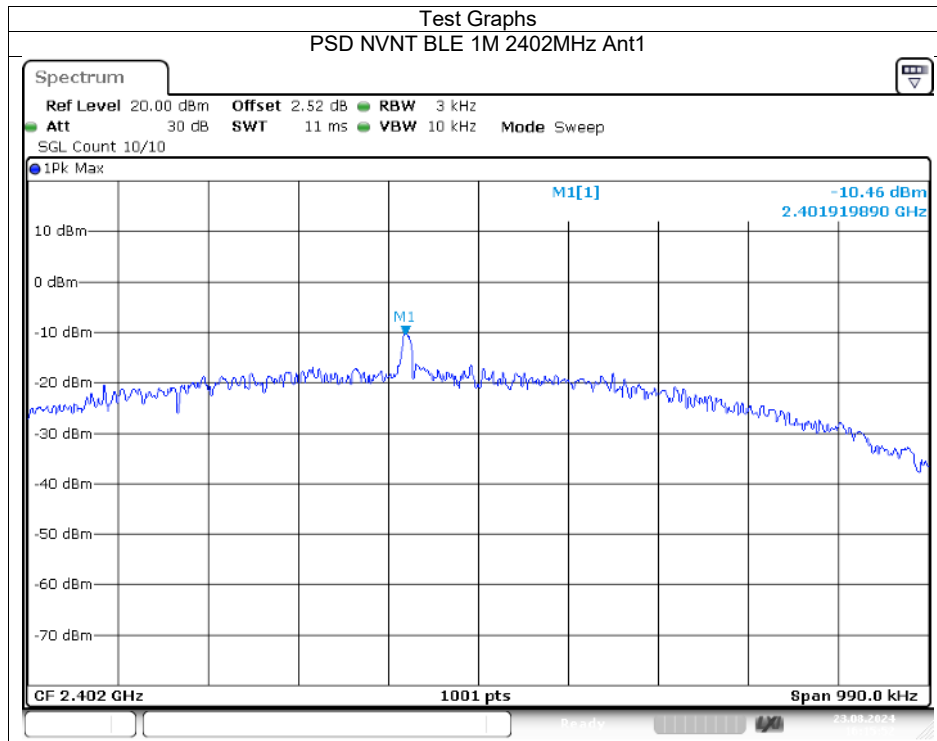

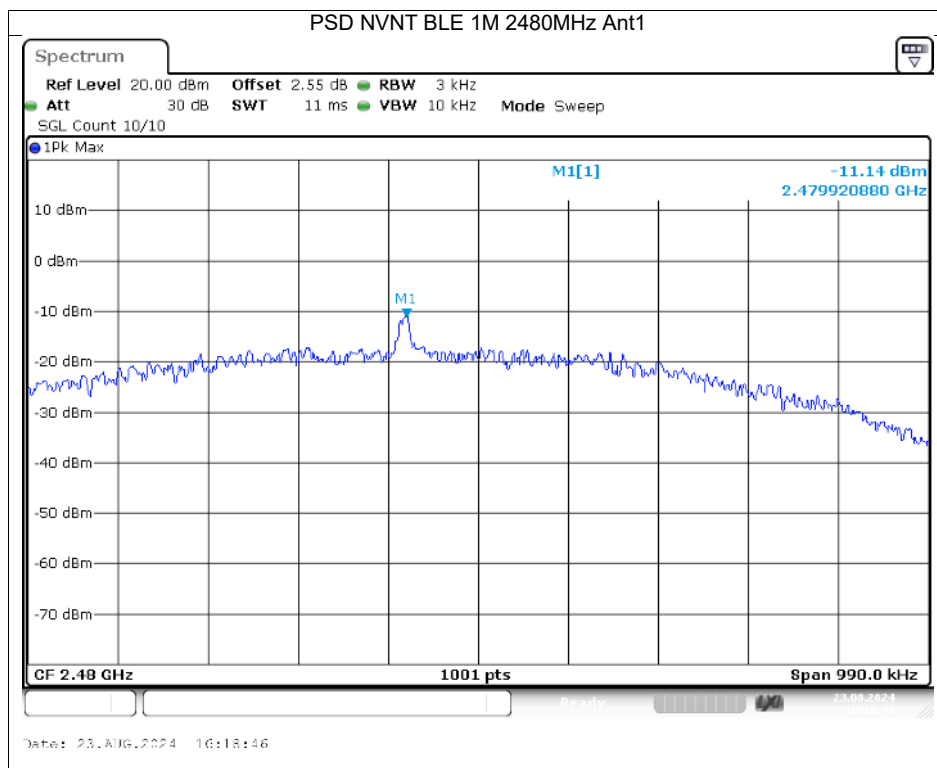

Band Edge

Condition	Mode	Frequency (MHz)	Antenna	Max Value (dBc)	Limit (dBc)	Verdict
NVNT	BLE 1M	2402	Ant1	-41.76	-20	Pass
NVNT	BLE 1M	2480	Ant1	-50.47	-20	Pass

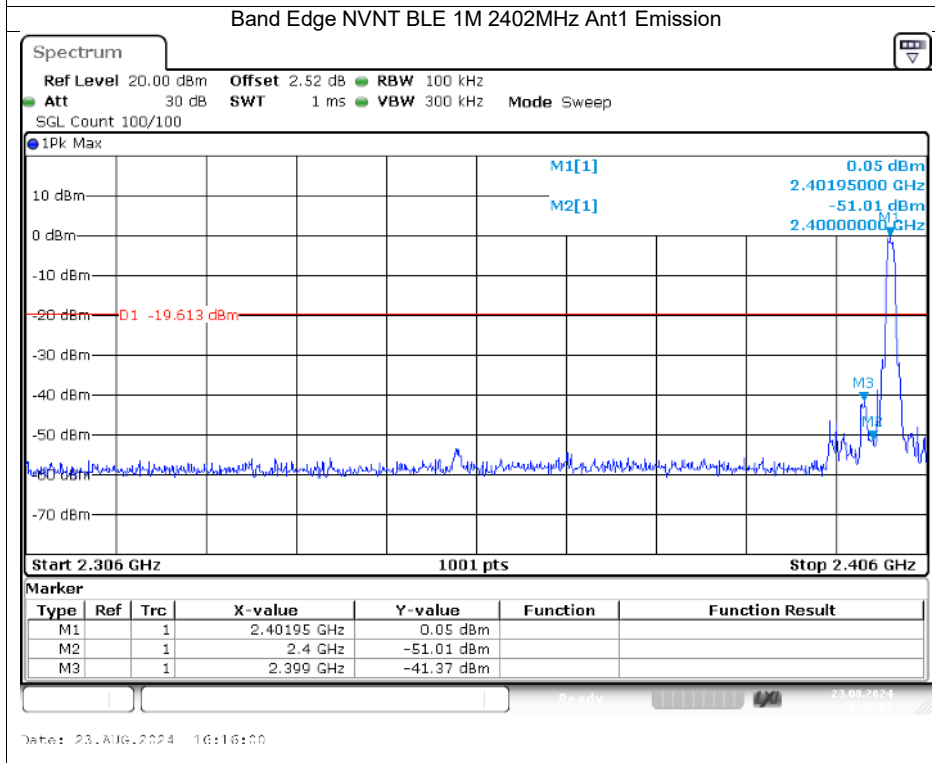
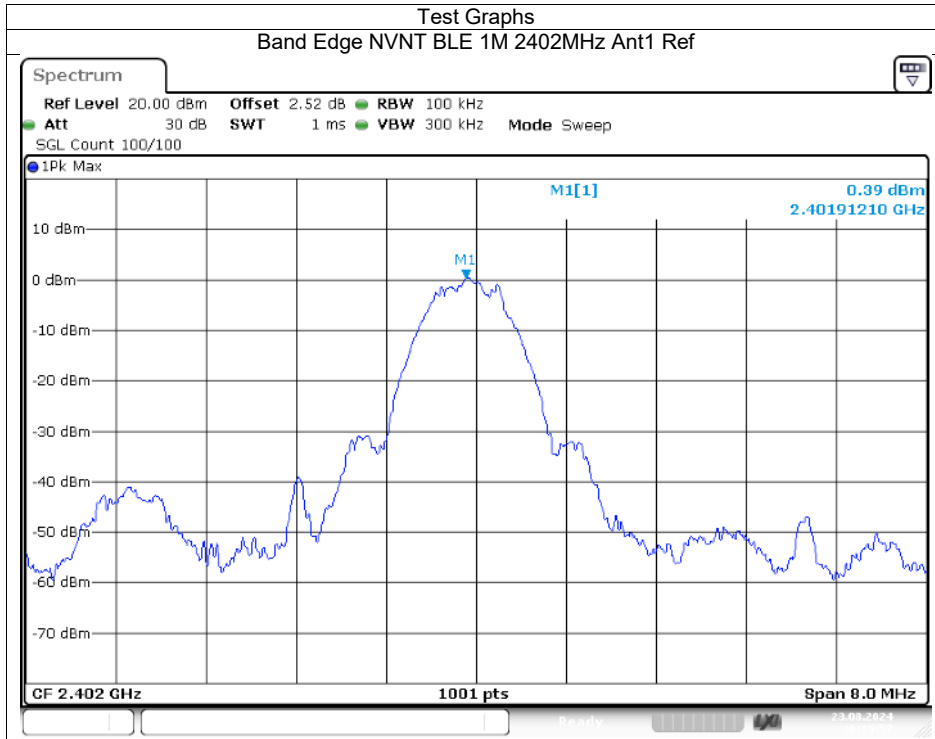

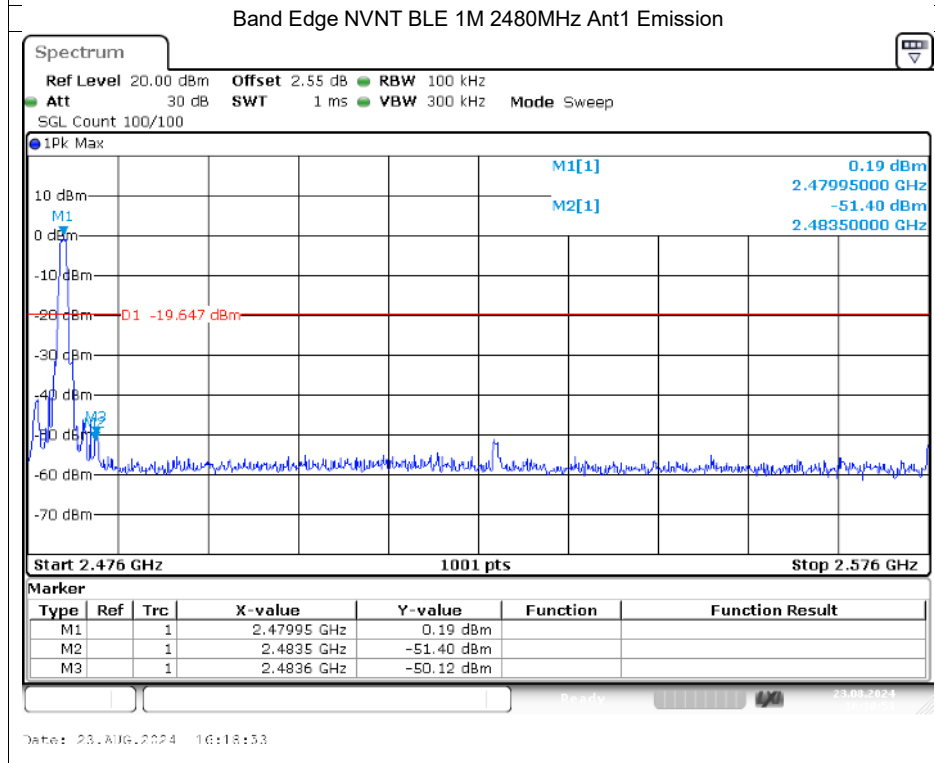
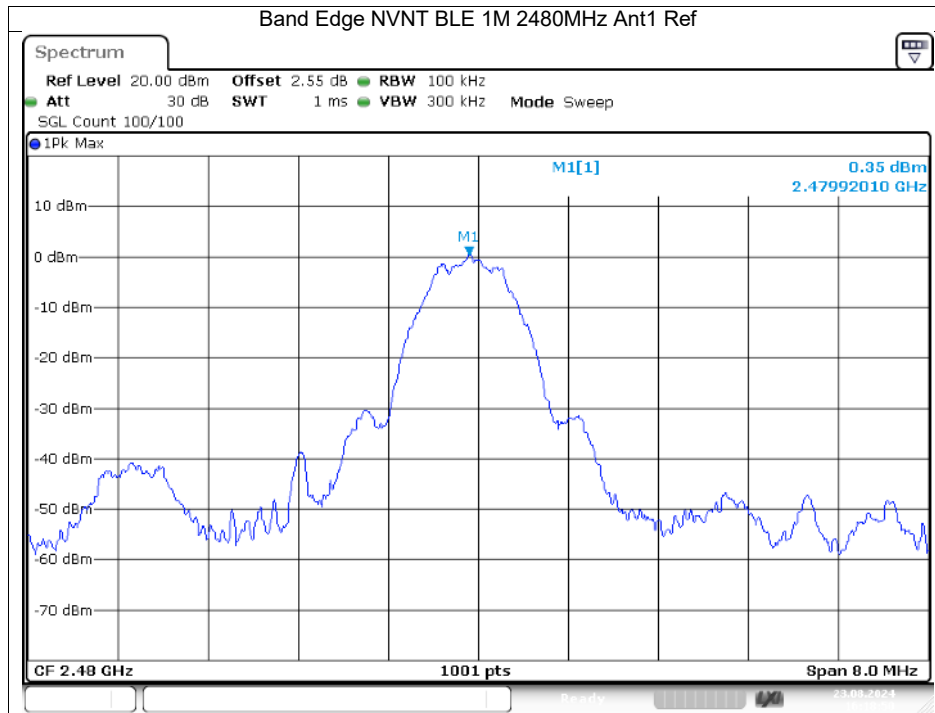

Conducted RF Spurious Emission

Condition	Mode	Frequency (MHz)	Antenna	Max Value (dBc)	Limit (dBc)	Verdict
NVNT	BLE 1M	2402	Ant1	-38.67	-20	Pass
NVNT	BLE 1M	2440	Ant1	-41.48	-20	Pass
NVNT	BLE 1M	2480	Ant1	-41.41	-20	Pass

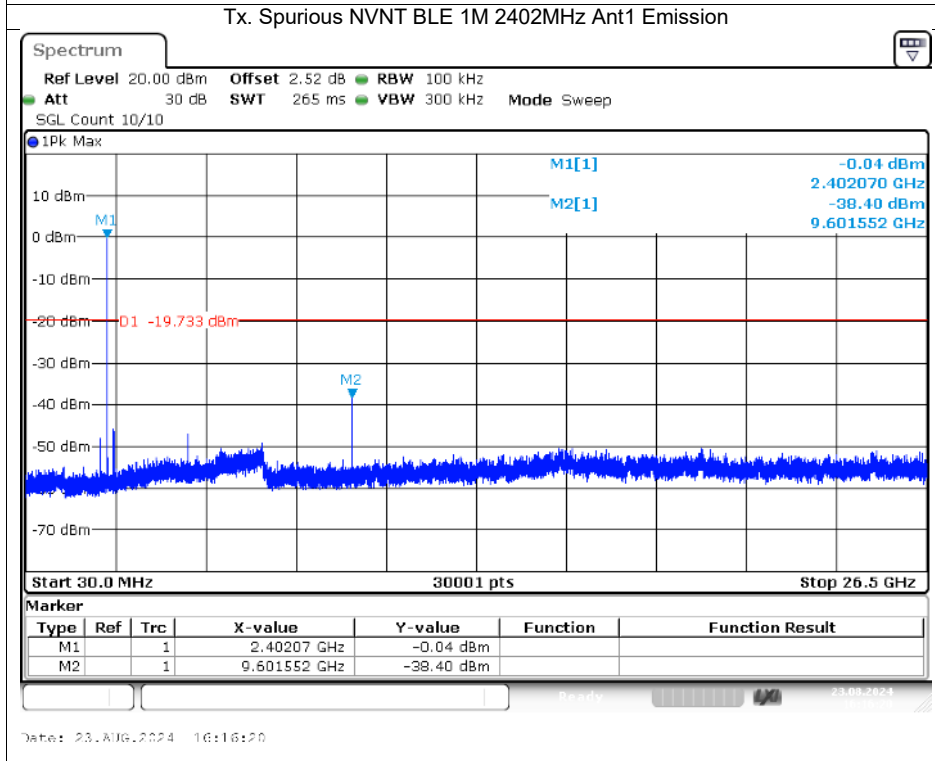
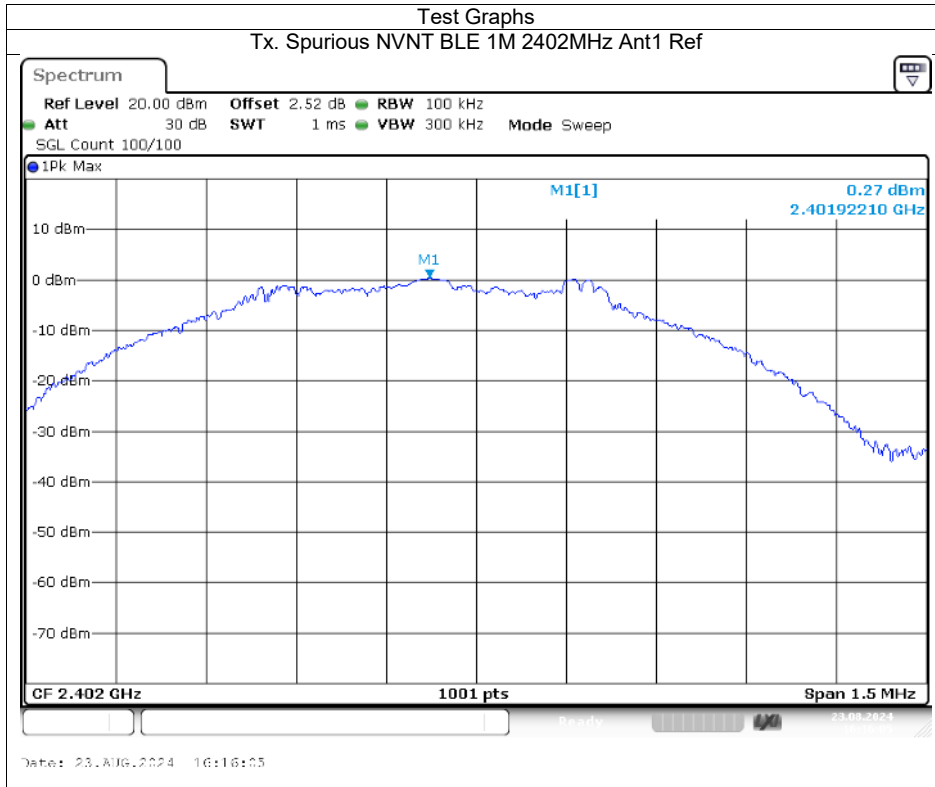

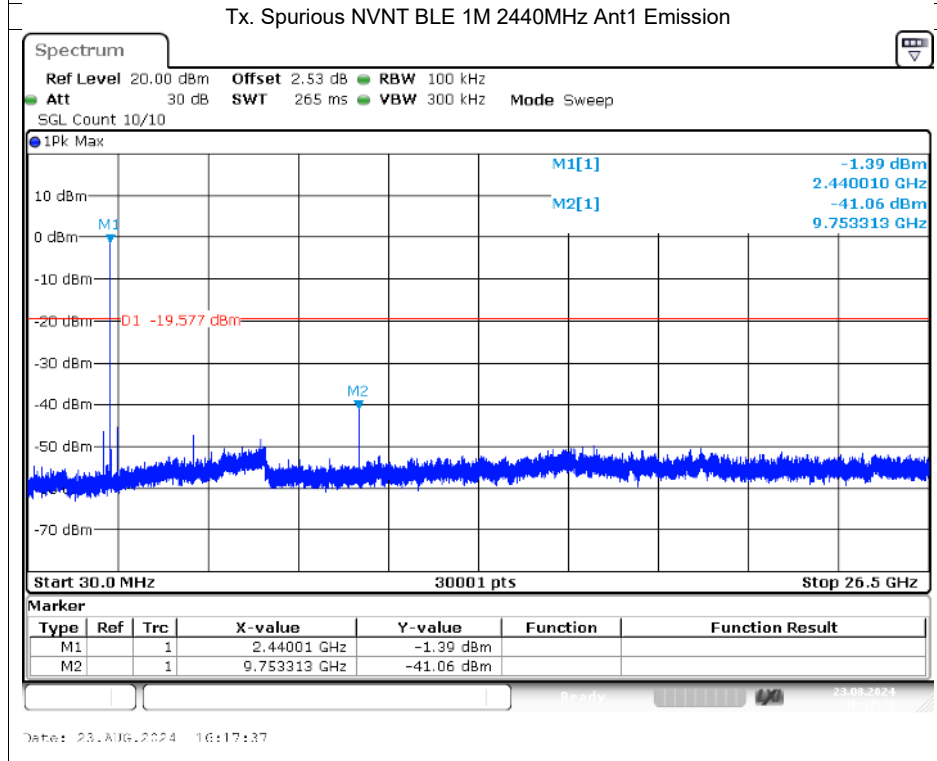
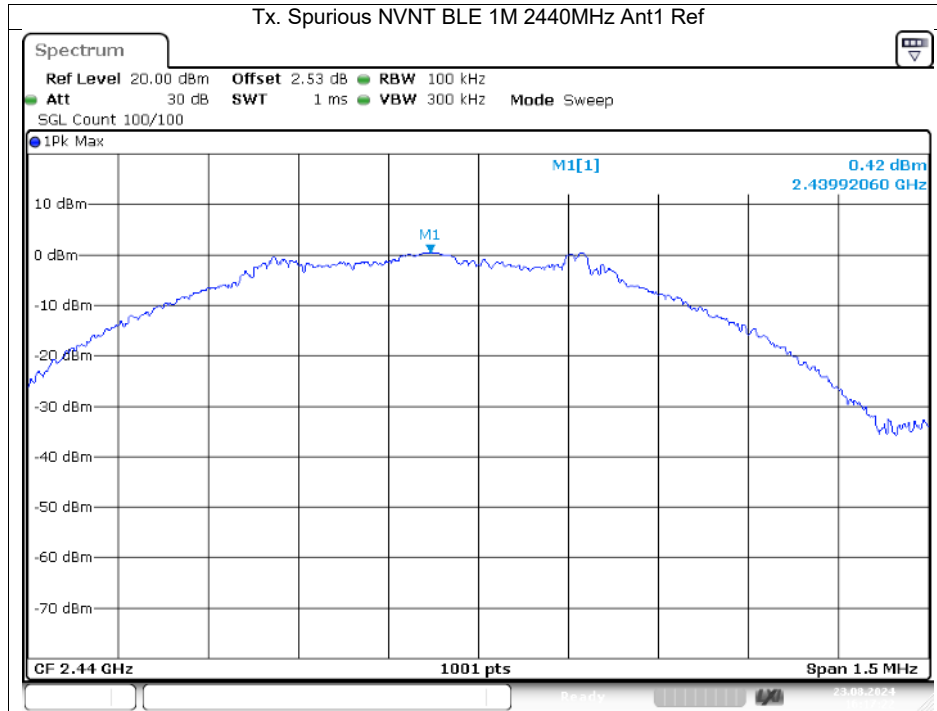

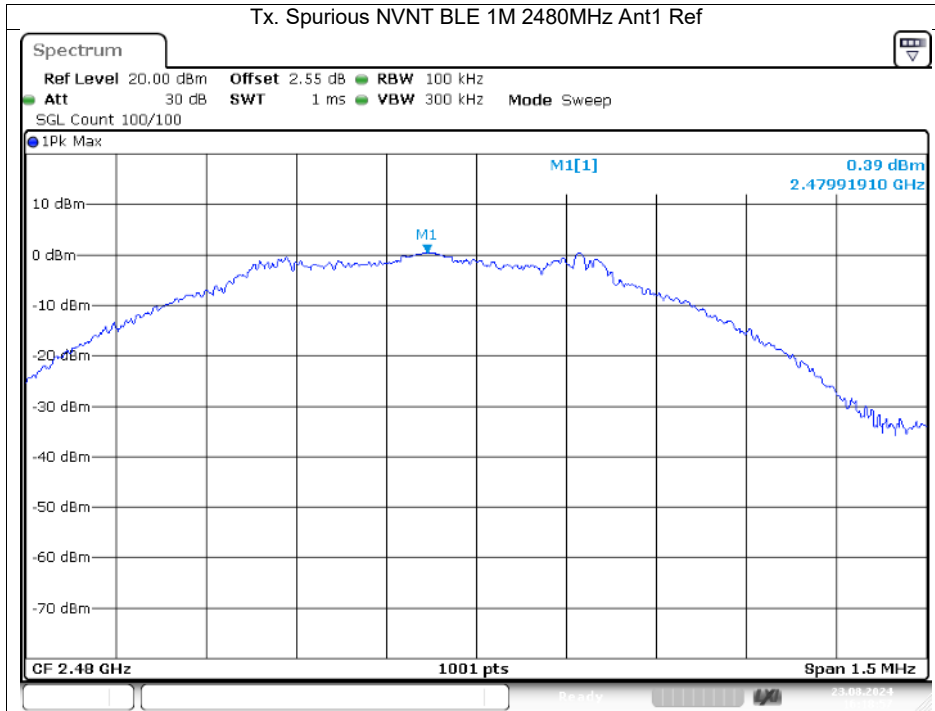

Date: 23. AUG. 2024 16:18:58

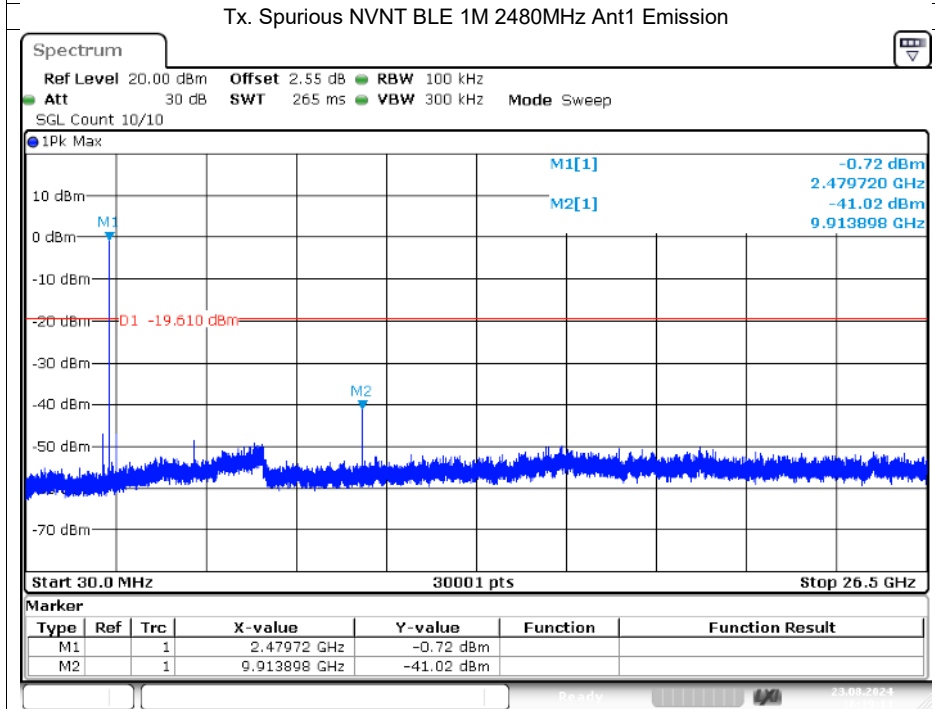

Date: 23. AUG. 2024 16:19:13

APPENDIX: PHOTOGRAPHS OF TEST CONFIGURATION

Please refer to the report: E04A24080217F00401.

APPENDIX: PHOTOGRAPHS OF THE EUT

Please refer to the report: E04A24080217F00401.

END OF REPORT