

# FCC SAR Test Report

APPLICANT : KonnectONE, LLC  
EQUIPMENT : 5G MiFi  
BRAND NAME : moxee  
MODEL NAME : K873HSVL  
FCC ID : 2APQU-K873HSVL  
STANDARD : FCC 47 CFR Part 2 (2.1093)

We, Sporton International (Kunshan) Inc., would like to declare that the tested sample has been evaluated in accordance with the test procedures given in 47 CFR Part 2.1093 and FCC KDB and has been in compliance with the applicable technical standards.

The test results in this report apply exclusively to the tested model / sample. Without written approval of Sporton International (Kunshan) Inc., the test report shall not be reproduced except in full.



Reviewed by: Nick Hu / Supervisor

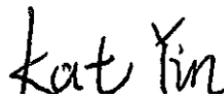

Approved by: Kat Yin / Manager



**Sporton International (Kunshan) Inc.**

No. 1098, Pengxi North Road, Kunshan Economic Development Zone Jiangsu Province 215300  
People's Republic of China



Table of Contents

1. Statement of Compliance ..... 4
2. Administration Data ..... 5
3. Guidance Applied ..... 5
4. Equipment Under Test (EUT) Information ..... 6
4.1 General Information ..... 6
4.2 General LTE SAR Test and Reporting Considerations ..... 8
4.3 General 5G NR SAR Test and Reporting Considerations ..... 10
5. Proximity Sensor Triggering Test ..... 11
5.1 Proximity sensor triggering distances(Per KDB616217§6.2) ..... 11
6. RF Exposure Limits ..... 13
6.1 Uncontrolled Environment ..... 13
6.2 Controlled Environment ..... 13
7. Specific Absorption Rate (SAR) ..... 14
7.1 Introduction ..... 14
7.2 SAR Definition ..... 14
8. System Description and Setup ..... 15
8.1 E-Field Probe ..... 16
8.2 Data Acquisition Electronics (DAE) ..... 16
8.3 Phantom ..... 17
8.4 Device Holder ..... 18
9. Measurement Procedures ..... 19
9.1 Spatial Peak SAR Evaluation ..... 19
9.2 Power Reference Measurement ..... 20
9.3 Area Scan ..... 20
9.4 Zoom Scan ..... 21
9.5 Volume Scan Procedures ..... 21
9.6 Power Drift Monitoring ..... 21
10. Test Equipment List ..... 22
11. System Verification ..... 23
11.1 Tissue Simulating Liquids ..... 23
11.2 Tissue Verification ..... 24
11.3 System Performance Check Results ..... 25
12. RF Exposure Positions ..... 26
12.1 Wireless Router ..... 26
13. Conducted RF Output Power (Unit: dBm) ..... 27
14. Antenna Location ..... 38
15. SAR Test Results ..... 39
15.1 Body SAR ..... 41
15.2 Repeated SAR Measurement ..... 50
16. Simultaneous Transmission Analysis ..... 51
16.1 Body Exposure Conditions ..... 52
17. Uncertainty Assessment ..... 56
18. References ..... 57
Appendix A. Plots of System Performance Check
Appendix B. Plots of High SAR Measurement
Appendix C. DASY Calibration Certificate
Appendix D. Test Setup Photos
Appendix E. Conducted RF Output Power Table





**1. Statement of Compliance**

The maximum results of Specific Absorption Rate (SAR) found during testing for **KonnectONE, LLC, 5G MiFi, K873HSVL**, are as follows.

Highest 1g SAR Summary				
Equipment Class	Frequency Band	Body(Separation 10mm)	Highest Simultaneous Transmission 1g SAR (W/kg)	
Licensed	LTE	Band 2	0.99	1.59
		Band 5	0.49	
		Band 13	0.67	
		Band 66/ Band 4	1.03	
		Band 48	0.44	
	5G NR	n2	<b>1.06</b>	
		n5	0.99	
		n66	1.02	
DTS	WLAN	2.4GHz WLAN	0.32	1.59
NII		5GHz WLAN	0.28	1.59
Date of Testing:		2021/9/25~ 2021/10/15		

**Remark:** This device supports LTE B4 and B66. Since the supported frequency span for LTE B4 falls completely within the supports frequency span for LTE B66, both LTE bands have the same target power, and both LTE bands share the same transmission path; therefore, SAR was only assessed for LTE B66.

**Declaration of Conformity:**

The test results with all measurement uncertainty excluded are presented in accordance with the regulation limits or requirements declared by manufacturers.

**Comments and Explanations:**

The declared of product specification for EUT presented in the report are provided by the manufacturer, and the manufacturer takes all the responsibilities for the accuracy of product specification.

This device is in compliance with Specific Absorption Rate (SAR) for general population/uncontrolled exposure limits (1.6 W/kg for Partial-Body 1g SAR, 4.0 W/kg for Product Specific 10g SAR) specified in FCC 47 CFR part 2 (2.1093) and ANSI/IEEE C95.1-1992, and had been tested in accordance with the measurement methods and procedures specified in IEEE 1528-2013 and FCC KDB publications.



2. Administration Data

Sporton International (Kunshan) Inc. is accredited to ISO/IEC 17025:2017 by American Association for Laboratory Accreditation with Certificate Number 5145.02.

Table with Testing Laboratory details including Test Firm, Test Site Location, and Test Site No. with sub-columns for Sporton Site No., FCC Designation No., and FCC Test Firm Registration No.

Table with Applicant details including Company Name and Address.

Table with Manufacturer details including Company Name and Address.

3. Guidance Applied

The Specific Absorption Rate (SAR) testing specification, method, and procedure for this device is in accordance with the following standards:

- List of standards including FCC 47 CFR Part 2 (2.1093), ANSI/IEEE C95.1-1992, IEEE 1528-2013, and various FCC KDB SAR measurement and reporting guidelines.

## **4. Equipment Under Test (EUT) Information**

### **4.1 General Information**

<b>Product Feature &amp; Specification</b>	
<b>Equipment Name</b>	5G MiFi
<b>Brand Name</b>	moxee
<b>Model Name</b>	K873HSVL
<b>FCC ID</b>	2APQU-K873HSVL
<b>IMEI Code</b>	35643460003405
<b>Wireless Technology and Frequency Range</b>	LTE Band 2: 1850 MHz ~ 1910 MHz LTE Band 4: 1710 MHz ~ 1755 MHz LTE Band 5: 824 MHz ~ 849 MHz LTE Band 13: 777 MHz ~ 787 MHz LTE Band 66: 1710 MHz ~ 1780 MHz LTE Band 48: 3550 MHz ~ 3700 MHz 5G NR n2 : 1850 MHz ~ 1910 MHz 5G NR n5 : 824 MHz ~ 849 MHz 5G NR n66 : 1710 MHz ~ 1780 MHz 5G NR n77: 3450 MHz ~ 3550 MHz, 3700 MHz ~ 3980 MHz WLAN 2.4GHz Band: 2412 MHz ~ 2462 MHz WLAN 5.2GHz Band: 5180 MHz ~ 5240 MHz WLAN 5.8GHz Band: 5745 MHz ~ 5825 MHz
<b>Mode</b>	LTE: QPSK, 16QAM, 64QAM, 256QAM 5G NR : CP-OFDM / DFT-s-OFDM, PI/2 BPSK,QPSK, 16QAM, 64QAM, 256QAM WLAN 2.4GHz 802.11b/g/n HT20/HT40 WLAN 2.4GHz 802.11ax HE20/HE40 WLAN 5GHz 802.11a/n HT20/HT40 WLAN 5GHz 802.11ac VHT20/VHT40/VHT80 WLAN 5GHz 802.11ax HE20/HE40/HE80
<b>HW Version</b>	873_V1.01_PCB
<b>SW Version</b>	K873HSVL_6.0.01_EQ102
<b>EUT Stage</b>	Identical Prototype
<b>Remark:</b>	
<ol style="list-style-type: none"> <li>1. This device does not support voice function.</li> <li>2. The device implements Proximity sensors trigger reduced power for the power management for SAR compliance at different exposure conditions (body) and the details about the power management decision and sensor detection are provided in the operational description. And the device will invoke corresponding work scenarios power level base on frequency bands/antennas, which can refer to power table at appendix E.</li> <li>3. For 5G NR test, using FTM (Factory Test Mode) to perform SAR with default 100% transmission.</li> <li>4. NSA and SA mode should perform SAR separately. For the maximum power of NSA mode is the same as SA total power level, so SA SAR can represent NSA mode SAR. Some NSA mode verified the worst case of SA mode, and this worst position NSA SAR can represent other position SAR to do collocated analysis.</li> <li>5. 5G NR NSA mode, the power level is the same as 5G NR SA mode, so 5G NR NSA mode and SA mode power table only show one time.</li> <li>6. 5G NR supports CP-OFDM and DFT-s-OFDM modulation, for DFT-s-OFDM power is higher than CP-OFDM, so only show DFT-s-OFDM power table and chose DFT-s-OFDM to perform SAR testing.</li> <li>7. For DFT-s-OFDM and CP-OFDM output power measurement reduction, according to 38.101 maximum power reduction for the CP-OFDM mode will not higher than DFT-s-OFDM mode, therefore, CP-OFDM measurement is unnecessary.</li> <li>8. 5G NR n77 supports MIMO mode, MIMO power have been verified and MIMO total power is the less than SISO power. Summed SISO SAR can represent MIMO SAR conservatively.</li> <li>9. 5G NR n77 located antenna 4 and antenna 5, only MIMO state, antenna 5 can work. Other situation, antenna 5 is not work. This test report, n77 perform SAR testing at antenna 5 is mainly for MIMO mode.</li> <li>10. This device supports 5G NR FR1 bands as following table, including NSA mode and SA mode. NSA and SA mode performed SAR separately.</li> <li>11. This is a report for change in FCC ID, there is no difference on the product design, all the test results are leveraged from original FCC ID: 2APJ4-SRT873, report number FA133010.</li> </ol>	



<5G NR>

Mode	Band	Duplex	SCS(KHz)	Bandwidths(BW)
SA	n2	FDD	15	5, 10, 15, 20
	n5	FDD	15	5, 10, 15, 20
	n66	FDD	15	5, 10, 15, 20
	n77	TDD	30	20,40,50,60,80,90,100
NSA	n2	FDD	15	5, 10, 15, 20
	n5	FDD	15	5, 10, 15, 20
	n66	FDD	15	5, 10, 15, 20
	n77	TDD	30	20,40,50,60,80,90,100



### 4.2 General LTE SAR Test and Reporting Considerations

Summarized necessary items addressed in KDB 941225 D05 v02r05																																																															
FCC ID	2APQU-K873HSVL																																																														
Equipment Name	5G MiFi																																																														
Operating Frequency Range of each LTE transmission band	LTE Band 2: 1850 MHz ~ 1910 MHz LTE Band 4: 1710 MHz ~ 1755 MHz LTE Band 5: 824 MHz ~ 849 MHz LTE Band 13: 777 MHz ~ 787 MHz LTE Band 66: 1710 MHz ~ 1780 MHz LTE Band 48: 3550 MHz ~ 3700 MHz																																																														
Channel Bandwidth	LTE Band 2: 1.4MHz, 3MHz, 5MHz, 10MHz, 15MHz, 20MHz LTE Band 4: 1.4MHz, 3MHz, 5MHz, 10MHz, 15MHz, 20MHz LTE Band 5: 1.4MHz, 3MHz, 5MHz, 10MHz LTE Band 13: 5MHz, 10MHz LTE Band 66: 1.4MHz, 3MHz, 5MHz, 10MHz, 15MHz, 20MHz LTE Band 48: 5MHz, 10MHz, 15MHz, 20MHz																																																														
uplink modulations used	QPSK / 16QAM / 64QAM / 256QAM																																																														
LTE Voice / Data requirements	Data only																																																														
LTE Release Version	R15, Cat18																																																														
CA Support	Supported, Uplink and Downlink																																																														
LTE MPR permanently built-in by design	<p><b>Table 6.2.3-1: Maximum Power Reduction (MPR) for Power Class 1, 2 and 3</b></p> <table border="1"> <thead> <tr> <th rowspan="2">Modulation</th> <th colspan="6">Channel bandwidth / Transmission bandwidth (N<sub>RB</sub>)</th> <th rowspan="2">MPR (dB)</th> </tr> <tr> <th>1.4 MHz</th> <th>3.0 MHz</th> <th>5 MHz</th> <th>10 MHz</th> <th>15 MHz</th> <th>20 MHz</th> </tr> </thead> <tbody> <tr> <td>QPSK</td> <td>&gt; 5</td> <td>&gt; 4</td> <td>&gt; 8</td> <td>&gt; 12</td> <td>&gt; 16</td> <td>&gt; 18</td> <td>≤ 1</td> </tr> <tr> <td>16 QAM</td> <td>≤ 5</td> <td>≤ 4</td> <td>≤ 8</td> <td>≤ 12</td> <td>≤ 16</td> <td>≤ 18</td> <td>≤ 1</td> </tr> <tr> <td>16 QAM</td> <td>&gt; 5</td> <td>&gt; 4</td> <td>&gt; 8</td> <td>&gt; 12</td> <td>&gt; 16</td> <td>&gt; 18</td> <td>≤ 2</td> </tr> <tr> <td>64 QAM</td> <td>≤ 5</td> <td>≤ 4</td> <td>≤ 8</td> <td>≤ 12</td> <td>≤ 16</td> <td>≤ 18</td> <td>≤ 2</td> </tr> <tr> <td>64 QAM</td> <td>&gt; 5</td> <td>&gt; 4</td> <td>&gt; 8</td> <td>&gt; 12</td> <td>&gt; 16</td> <td>&gt; 18</td> <td>≤ 3</td> </tr> <tr> <td>256 QAM</td> <td colspan="6" style="text-align: center;">≥ 1</td> <td>≤ 5</td> </tr> </tbody> </table>	Modulation	Channel bandwidth / Transmission bandwidth (N <sub>RB</sub> )						MPR (dB)	1.4 MHz	3.0 MHz	5 MHz	10 MHz	15 MHz	20 MHz	QPSK	> 5	> 4	> 8	> 12	> 16	> 18	≤ 1	16 QAM	≤ 5	≤ 4	≤ 8	≤ 12	≤ 16	≤ 18	≤ 1	16 QAM	> 5	> 4	> 8	> 12	> 16	> 18	≤ 2	64 QAM	≤ 5	≤ 4	≤ 8	≤ 12	≤ 16	≤ 18	≤ 2	64 QAM	> 5	> 4	> 8	> 12	> 16	> 18	≤ 3	256 QAM	≥ 1						≤ 5
Modulation	Channel bandwidth / Transmission bandwidth (N <sub>RB</sub> )						MPR (dB)																																																								
	1.4 MHz	3.0 MHz	5 MHz	10 MHz	15 MHz	20 MHz																																																									
QPSK	> 5	> 4	> 8	> 12	> 16	> 18	≤ 1																																																								
16 QAM	≤ 5	≤ 4	≤ 8	≤ 12	≤ 16	≤ 18	≤ 1																																																								
16 QAM	> 5	> 4	> 8	> 12	> 16	> 18	≤ 2																																																								
64 QAM	≤ 5	≤ 4	≤ 8	≤ 12	≤ 16	≤ 18	≤ 2																																																								
64 QAM	> 5	> 4	> 8	> 12	> 16	> 18	≤ 3																																																								
256 QAM	≥ 1						≤ 5																																																								
LTE A-MPR	In the base station simulator configuration, Network Setting value is set to NS_01 to disable A-MPR during SAR testing and the LTE SAR tests was transmitting on all TTI frames (Maximum TTI)																																																														
Spectrum plots for RB configuration	A properly configured base station simulator was used for the SAR and power measurement; therefore, spectrum plots for each RB allocation and offset configuration are not included in the SAR report.																																																														
Power reduction applied to satisfy SAR compliance	Yes, body will trigger reduced power for some LTE bands, the detail please referred to section 13.																																																														
LTE Carrier Aggregation Combinations	Inter-Band and Intra-Band possible combinations and the detail power verification please referred to section 13.																																																														
LTE Carrier Aggregation Additional Information	1. This device supports LTE Carrier Aggregation (CA) in the uplink with two component carriers in the uplink. SAR Measurements and conducted powers were evaluated per FCC Guidance. 2. This device supports maximum of 7 carriers in the downlink and 2 carriers in the uplink. Additional following LTE Release features are not supported: Relay, HetNet, Enhanced MIMO, eICI, WiFi Offloading, MDH, eMBMA, Cross-Carrier Scheduling, Enhanced SC-FDMA.																																																														



Transmission (H, M, L) channel numbers and frequencies in each LTE band												
LTE Band 2												
	Bandwidth 1.4 MHz		Bandwidth 3 MHz		Bandwidth 5 MHz		Bandwidth 10 MHz		Bandwidth 15 MHz		Bandwidth 20 MHz	
	Ch. #	Freq. (MHz)	Ch. #	Freq. (MHz)	Ch. #	Freq. (MHz)	Ch. #	Freq. (MHz)	Ch. #	Freq. (MHz)	Ch. #	Freq. (MHz)
L	18607	1850.7	18615	1851.5	18625	1852.5	18650	1855	18675	1857.5	18700	1860
M	18900	1880	18900	1880	18900	1880	18900	1880	18900	1880	18900	1880
H	19193	1909.3	19185	1908.5	19175	1907.5	19150	1905	19125	1902.5	19100	1900
LTE Band 4												
	Bandwidth 1.4 MHz		Bandwidth 3 MHz		Bandwidth 5 MHz		Bandwidth 10 MHz		Bandwidth 15 MHz		Bandwidth 20 MHz	
	Ch. #	Freq. (MHz)	Ch. #	Freq. (MHz)	Ch. #	Freq. (MHz)	Ch. #	Freq. (MHz)	Ch. #	Freq. (MHz)	Ch. #	Freq. (MHz)
L	19957	1710.7	19965	1711.5	19975	1712.5	20000	1715	20025	1717.5	20050	1720
M	20175	1732.5	20175	1732.5	20175	1732.5	20175	1732.5	20175	1732.5	20175	1732.5
H	20393	1754.3	20385	1753.5	20375	1752.5	20350	1750	20325	1747.5	20300	1745
LTE Band 5												
	Bandwidth 1.4 MHz		Bandwidth 3 MHz		Bandwidth 5 MHz		Bandwidth 10 MHz		Bandwidth 15 MHz		Bandwidth 20 MHz	
	Ch. #	Freq. (MHz)	Ch. #	Freq. (MHz)	Ch. #	Freq. (MHz)	Ch. #	Freq. (MHz)	Ch. #	Freq. (MHz)	Ch. #	Freq. (MHz)
L	20407	824.7	20415	825.5	20425	826.5	20450	829	20450	829	20450	829
M	20525	836.5	20525	836.5	20525	836.5	20525	836.5	20525	836.5	20525	836.5
H	20643	848.3	20635	847.5	20625	846.5	20600	844	20600	844	20600	844
LTE Band 13												
	Bandwidth 5 MHz					Bandwidth 10 MHz						
	Channel #		Freq.(MHz)			Channel #		Freq.(MHz)				
L	23205		779.5			23230		782				
M	23230		782									
H	23255		784.5									

LTE Band 66												
	Bandwidth 1.4 MHz		Bandwidth 3 MHz		Bandwidth 5 MHz		Bandwidth 10 MHz		Bandwidth 15 MHz		Bandwidth 20 MHz	
	Ch. #	Freq. (MHz)	Ch. #	Freq. (MHz)	Ch. #	Freq. (MHz)	Ch. #	Freq. (MHz)	Ch. #	Freq. (MHz)	Ch. #	Freq. (MHz)
L	131979	1710.7	131987	1711.5	131997	1712.5	132022	1715	132047	1717.5	132072	1720
M	132322	1745	132322	1745	132322	1745	132322	1745	132322	1745	132322	1745
H	132665	1779.3	132657	1778.5	132647	1777.5	132622	1775	132597	1772.5	132572	1770

LTE Band 48								
	Bandwidth 5 MHz		Bandwidth 10 MHz		Bandwidth 15 MHz		Bandwidth 20 MHz	
	Ch. #	Freq. (MHz)	Ch. #	Freq. (MHz)	Ch. #	Freq. (MHz)	Ch. #	Freq. (MHz)
L	55265	3552.5	55290	3555	55315	3557.5	55340	3560
LM	55810	3607	55815	3607.5	55820	3608	55830	3609
MH	56170	3643	56165	3642.5	56160	3642	56150	3641
H	56715	3697.5	56690	3695	56665	3692.5	56640	3690



4.3 General 5G NR SAR Test and Reporting Considerations

5G NR Information	
Operating Frequency Range of each 5G NR transmission band	5G NR n2 : 1850 MHz ~ 1910 MHz 5G NR n5 : 824 MHz ~ 849 MHz 5G NR n66 : 1710 MHz ~ 1780 MHz 5G NR n77: 3450 MHz ~ 3550 MHz, 3700 MHz ~ 3980 MHz
Channel Bandwidth	5G NR n2: 5MHz, 10MHz, 15MHz, 20MHz 5G NR n5: 5MHz, 10MHz, 15MHz, 20MHz 5G NR n66: 5MHz, 10MHz, 15MHz, 20MHz 5G NR n77: 20MHz, 40MHz, 50MHz, 60MHz, 80MHz, 90MHz, 100MHz
SCS	FDD: SCS15KHz, TDD: SCS30KHz
uplink modulations used	DFT-s-OFDM: PI/2 BPSK / QPSK / 16QAM / 64QAM / 256QAM CP-OFDM QPSK / 16QAM / 64QAM / 256QAM
A-MPR (Additional MPR) disabled for SAR Testing?	Yes
LTE Anchor Bands for n2	LTE B5/13/66
LTE Anchor Bands for n5	LTE B2/48/66
LTE Anchor Bands for n66	LTE B2/5/13
LTE Anchor Bands for n77	LTE B2/13/66

Transmission (H, M, L) channel numbers and frequencies in each 5G NR band

NR Band 2								
	Bandwidth 5MHz		Bandwidth 10MHz		Bandwidth 15MHz		Bandwidth 20MHz	
	Ch. #	Freq. (MHz)	Ch. #	Freq. (MHz)	Ch. #	Freq. (MHz)	Ch. #	Freq. (MHz)
L	370500	1852.5	371000	1855	371500	1857.5	372000	1860
M	376000	1880	376000	1880	376000	1880	376000	1880
H	381500	1907.5	381000	1905	380500	1902.5	380000	1900
NR Band 5								
	Bandwidth 5MHz		Bandwidth 10MHz		Bandwidth 15MHz		Bandwidth 20MHz	
	Ch. #	Freq. (MHz)	Ch. #	Freq. (MHz)	Ch. #	Freq. (MHz)	Ch. #	Freq. (MHz)
L	165300	826.5	165800	829	166300	831.5	166800	834
M	167300	836.5	167300	836.5	167300	836.5	167300	836.5
H	169300	846.5	168800	844	168300	841.5	167800	839
NR Band 66								
	Bandwidth 5MHz		Bandwidth 10MHz		Bandwidth 15MHz		Bandwidth 20MHz	
	Ch. #	Freq. (MHz)	Ch. #	Freq. (MHz)	Ch. #	Freq. (MHz)	Ch. #	Freq. (MHz)
L	342500	1712.5	343000	1715	343500	1717.5	344000	1720
M	349000	1745	349000	1745	349000	1745	349000	1745
H	355500	1777.5	355000	1775	354500	1772.5	354000	1770

NR Band 77														
	Bandwidth 20MHz		Bandwidth 40MHz		Bandwidth 50MHz		Bandwidth 60MHz		Bandwidth 80MHz		Bandwidth 90MHz		Bandwidth 100MHz	
	Ch. #	Freq. (MHz)	Ch. #	Freq. (MHz)	Ch. #	Freq. (MHz)	Ch. #	Freq. (MHz)	Ch. #	Freq. (MHz)	Ch. #	Freq. (MHz)	Ch. #	Freq. (MHz)
L	647334	3710.01	648000	3720	648334	3725.01	648668	3730.02	649334	3740.01	649668	3745.02	650000	3750
M	656000	3840	656000	3840	656000	3840	656000	3840	656000	3840	656000	3840	656000	3840
H	664668	3970.02	664000	3960	663668	3955.02	663334	3950.01	662668	3940.02	662334	3935.01	662000	3930

For 3450 MHz ~ 3550 MHz

NR Band 77														
	Bandwidth 20MHz		Bandwidth 40MHz		Bandwidth 50MHz		Bandwidth 60MHz		Bandwidth 80MHz		Bandwidth 90MHz		Bandwidth 100MHz	
	Ch. #	Freq. (MHz)	Ch. #	Freq. (MHz)	Ch. #	Freq. (MHz)	Ch. #	Freq. (MHz)	Ch. #	Freq. (MHz)	Ch. #	Freq. (MHz)	Ch. #	Freq. (MHz)
L	630668	3460.02	631334	3470.01	631668	3475.02	632000	3480	632668	3490.02	633000	3495		
M	633334	3500.01	633334	3500.01	633334	3500.01	633334	3500.01	633334	3500.01	633334	3500.01	633334	3500.01
H	636000	3540	635334	3530.01	635000	3525	634668	3520.02	634000	3510	633668	3505.02		

### 5. Proximity Sensor Triggering Test

#### 5.1 Proximity sensor triggering distances(Per KDB616217§6.2)

1. Proximity sensor triggering distance testing was performed according to the procedures outlined in KDB 616217 D04 section 6.2, and EUT moving further away from the flat phantom and EUT moving toward the flat phantom were both assessed and the tissue-equivalent medium for highest frequency (1900MHz) and lowest (750MHz) frequency was used for proximity sensor triggering testing.
2. Capacitive proximity sensors placed coincident with antenna elements at the antenna 0 and antenna 6.
3. The sensors used to detect the proximity of the user's body at the front/back/left /top sides of the device use a detection threshold distance. The data shown in the sections below shows the distance(s). When those sides are detected, reduced power will be active.
4. For verification of compliance of power reduction scheme, additional SAR testing with EUT transmitting at full RF power at a conservative trigger distance -1mm was performed.

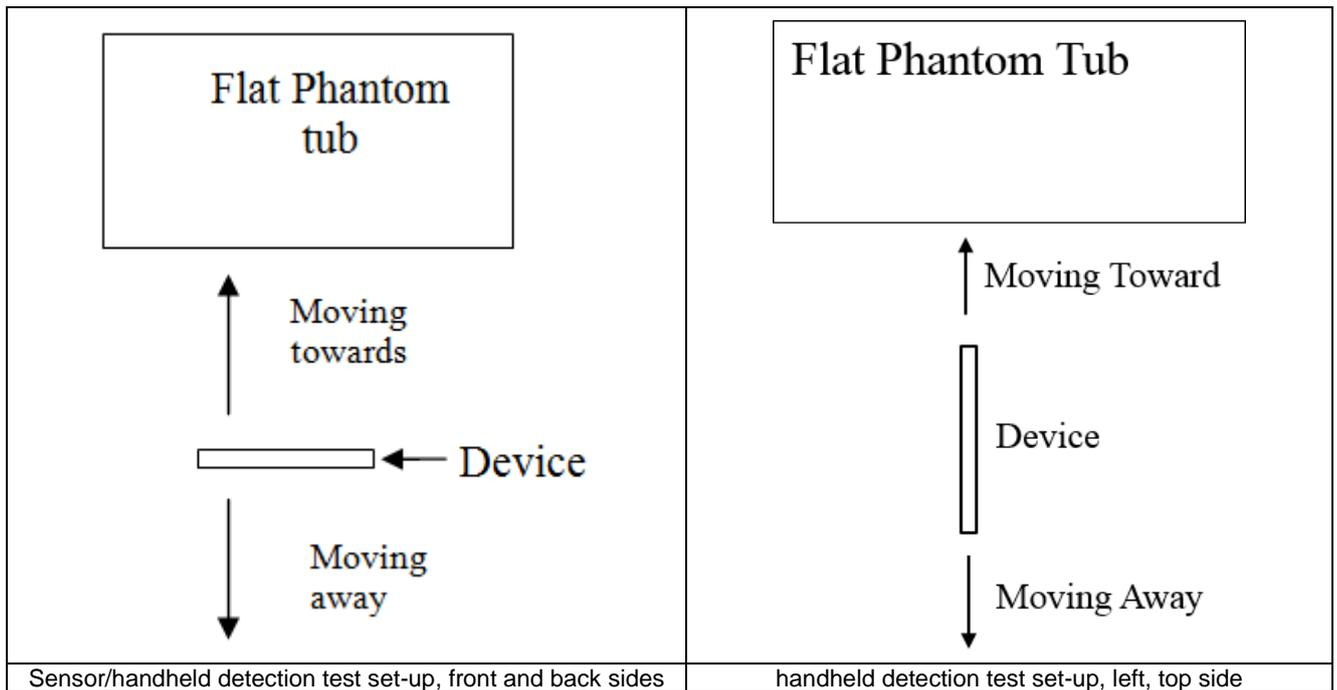

**<P-Sensor for ANT0>**

Proximity Sensor Triggering Distance (mm)						
Position	Front		Back		Left Side	
	Moving towards	Moving away	Moving towards	Moving away	Moving towards	Moving away
Minimum	22	24	18	25	32	34

**<P-Sensor for ANT6>**

Proximity Sensor Triggering Distance (mm)						
Position	Front		Back		Top Side	
	Moving towards	Moving away	Moving towards	Moving away	Moving towards	Moving away
Minimum	18	20	18	21	19	22

## 6. RF Exposure Limits

### 6.1 Uncontrolled Environment

Uncontrolled Environments are defined as locations where there is the exposure of individuals who have no knowledge or control of their exposure. The general population/uncontrolled exposure limits are applicable to situations in which the general public may be exposed or in which persons who are exposed as a consequence of their employment may not be made fully aware of the potential for exposure or cannot exercise control over their exposure. Members of the general public would come under this category when exposure is not employment-related; for example, in the case of a wireless transmitter that exposes persons in its vicinity.

### 6.2 Controlled Environment

Controlled Environments are defined as locations where there is exposure that may be incurred by persons who are aware of the potential for exposure, (i.e. as a result of employment or occupation). In general, occupational/controlled exposure limits are applicable to situations in which persons are exposed as a consequence of their employment, who have been made fully aware of the potential for exposure and can exercise control over their exposure. The exposure category is also applicable when the exposure is of a transient nature due to incidental passage through a location where the exposure levels may be higher than the general population/uncontrolled limits, but the exposed person is fully aware of the potential for exposure and can exercise control over his or her exposure by leaving the area or by some other appropriate means.

**Limits for Occupational/Controlled Exposure (W/kg)**

Whole-Body	Partial-Body	Hands, Wrists, Feet and Ankles
0.4	8.0	20.0

**Limits for General Population/Uncontrolled Exposure (W/kg)**

Whole-Body	Partial-Body	Hands, Wrists, Feet and Ankles
0.08	1.6	4.0

Whole-Body SAR is averaged over the entire body, partial-body SAR is averaged over any 1gram of tissue defined as a tissue volume in the shape of a cube. SAR for hands, wrists, feet and ankles is averaged over any 10 grams of tissue defined as a tissue volume in the shape of a cube.

## **7. Specific Absorption Rate (SAR)**

### **7.1 Introduction**

SAR is related to the rate at which energy is absorbed per unit mass in an object exposed to a radio field. The SAR distribution in a biological body is complicated and is usually carried out by experimental techniques or numerical modeling. The standard recommends limits for two tiers of groups, occupational/controlled and general population/uncontrolled, based on a person's awareness and ability to exercise control over his or her exposure. In general, occupational/controlled exposure limits are higher than the limits for general population/uncontrolled.

### **7.2 SAR Definition**

The SAR definition is the time derivative (rate) of the incremental energy (dW) absorbed by (dissipated in) an incremental mass (dm) contained in a volume element (dv) of a given density ( $\rho$ ). The equation description is as below:

$$\text{SAR} = \frac{d}{dt} \left( \frac{dW}{dm} \right) = \frac{d}{dt} \left( \frac{dW}{\rho dv} \right)$$

SAR is expressed in units of Watts per kilogram (W/kg)

$$\text{SAR} = \frac{\sigma |E|^2}{\rho}$$

Where:  $\sigma$  is the conductivity of the tissue,  $\rho$  is the mass density of the tissue and E is the RMS electrical field strength.

## 8. System Description and Setup

The DASY system used for performing compliance tests consists of the following items:

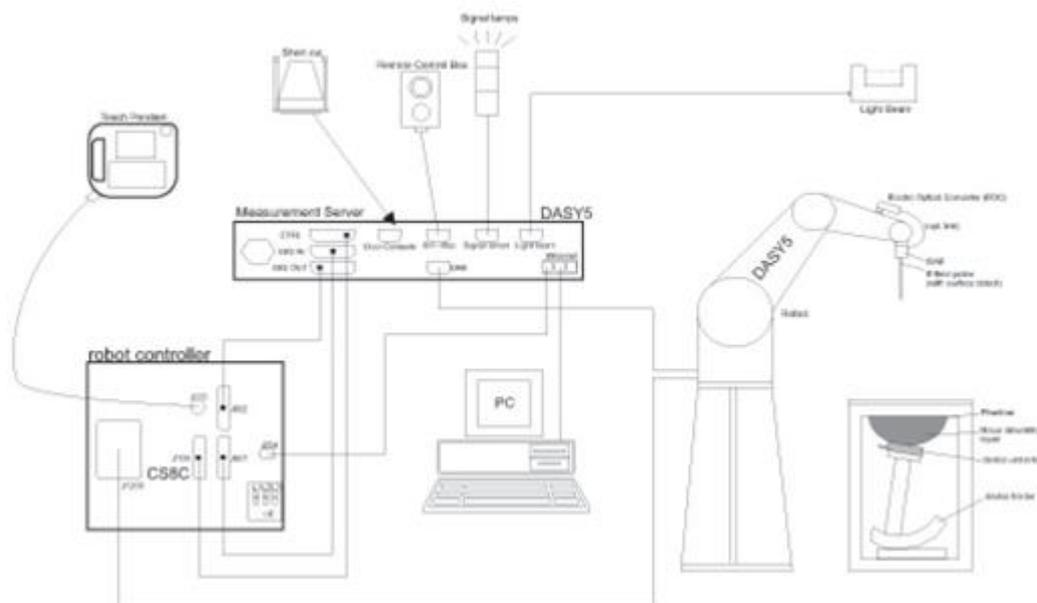

- A standard high precision 6-axis robot with controller, teach pendant and software. An arm extension for accommodating the data acquisition electronics (DAE).
- An isotropic Field probe optimized and calibrated for the targeted measurement.
- A data acquisition electronics (DAE) which performs the signal amplification, signal multiplexing, AD-conversion, offset measurements, mechanical surface detection, collision detection, etc. The unit is battery powered with standard or rechargeable batteries. The signal is optically transmitted to the EOC.
- The Electro-optical converter (EOC) performs the conversion from optical to electrical signals for the digital communication to the DAE. To use optical surface detection, a special version of the EOC is required. The EOC signal is transmitted to the measurement server.
- The function of the measurement server is to perform the time critical tasks such as signal filtering, control of the robot operation and fast movement interrupts.
- The Light Beam used is for probe alignment. This improves the (absolute) accuracy of the probe positioning.
- A computer running WinXP or Win7 and the DASY5 software.
- Remote control and teach pendant as well as additional circuitry for robot safety such as warning lamps, etc.
- The phantom, the device holder and other accessories according to the targeted measurement.

**8.1 E-Field Probe**

The SAR measurement is conducted with the dosimetric probe (manufactured by SPEAG).The probe is specially designed and calibrated for use in liquid with high permittivity. The dosimetric probe has special calibration in liquid at different frequency. This probe has a built in optical surface detection system to prevent from collision with phantom.

**<EX3DV4 Probe>**

<b>Construction</b>	Symmetric design with triangular core Built-in shielding against static charges PEEK enclosure material (resistant to organic solvents, e.g., DGBE)	
<b>Frequency</b>	10 MHz – >6 GHz Linearity: ±0.2 dB (30 MHz – 6 GHz)	
<b>Directivity</b>	±0.3 dB in TSL (rotation around probe axis) ±0.5 dB in TSL (rotation normal to probe axis)	
<b>Dynamic Range</b>	10 µW/g – >100 mW/g Linearity: ±0.2 dB (noise: typically <1 µW/g)	
<b>Dimensions</b>	Overall length: 337 mm (tip: 20 mm) Tip diameter: 2.5mm (body: 12 mm) Typical distance from probe tip to dipole centers: 1 mm	

**8.2 Data Acquisition Electronics (DAE)**

The data acquisition electronics (DAE) consists of a highly sensitive electrometer-grade preamplifier with auto-zeroing, a channel and gain-switching multiplexer, a fast 16 bit AD-converter and a command decoder and control logic unit. Transmission to the measurement server is accomplished through an optical downlink for data and status information as well as an optical uplink for commands and the clock.

The input impedance of the DAE is 200 MOhm; the inputs are symmetrical and floating. Common mode rejection is above 80 dB.



**Photo of DAE**

**8.3 Phantom**

**<SAM Twin Phantom>**

<b>Shell Thickness</b>	2 ± 0.2 mm; Center ear point: 6 ± 0.2 mm	
<b>Filling Volume</b>	Approx. 25 liters	
<b>Dimensions</b>	Length: 1000 mm; Width: 500 mm; Height: adjustable feet	
<b>Measurement Areas</b>	Left Hand, Right Hand, Flat Phantom	

The bottom plate contains three pair of bolts for locking the device holder. The device holder positions are adjusted to the standard measurement positions in the three sections. A white cover is provided to tap the phantom during off-periods to prevent water evaporation and changes in the liquid parameters. On the phantom top, three reference markers are provided to identify the phantom position with respect to the robot.

**<ELI Phantom>**

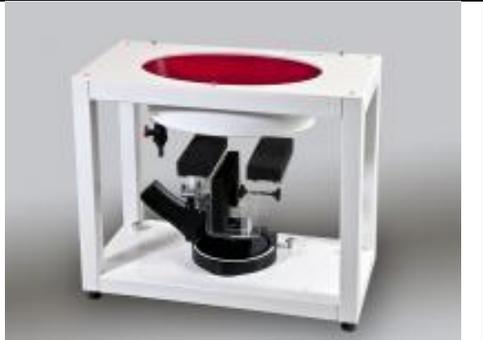
<b>Shell Thickness</b>	2 ± 0.2 mm (sagging: <1%)	
<b>Filling Volume</b>	Approx. 30 liters	
<b>Dimensions</b>	Major ellipse axis: 600 mm Minor axis: 400 mm	

The ELI phantom is intended for compliance testing of handheld and body-mounted wireless devices in the frequency range of 30 MHz to 6 GHz. ELI4 is fully compatible with standard and all known tissue simulating liquids.

### 8.4 Device Holder

#### <Mounting Device for Hand-Held Transmitter>

In combination with the Twin SAM V5.0/V5.0c or ELI phantoms, the Mounting Device for Hand-Held Transmitters enables rotation of the mounted transmitter device to specified spherical coordinates. At the heads, the rotation axis is at the ear opening. Transmitter devices can be easily and accurately positioned according to IEC 62209-1, IEEE 1528, FCC, or other specifications. The device holder can be locked for positioning at different phantom sections (left head, right head, flat). And upgrade kit to Mounting Device to enable easy mounting of wider devices like big smart-phones, e-books, small tablets, etc. It holds devices with width up to 140 mm.



Mounting Device for Hand-Held Transmitters



Mounting Device Adaptor for Wide-Phones

#### <Mounting Device for Laptops and other Body-Worn Transmitters>

The extension is lightweight and made of POM, acrylic glass and foam. It fits easily on the upper part of the mounting device in place of the phone positioned. The extension is fully compatible with the SAM Twin and ELI phantoms.



Mounting Device for Laptops

## 9. Measurement Procedures

The measurement procedures are as follows:

### <Conducted power measurement>

- (a) For WWAN power measurement, use base station simulator to configure EUT WWAN transmission in conducted connection with RF cable, at maximum power in each supported wireless interface and frequency band.
- (b) Read the WWAN RF power level from the base station simulator.
- (c) For WLAN/BT power measurement, use engineering software to configure EUT WLAN/BT continuously transmission, at maximum RF power in each supported wireless interface and frequency band
- (d) Connect EUT RF port through RF cable to the power meter, and measure WLAN/BT output power

### <SAR measurement>

- (a) Use base station simulator to configure EUT WWAN transmission in radiated connection, and engineering software to configure EUT WLAN/BT continuously transmission, at maximum RF power, in the highest power channel.
- (b) Place the EUT in the positions as Appendix D demonstrates.
- (c) Set scan area, grid size and other setting on the DASY software.
- (d) Measure SAR results for the highest power channel on each testing position.
- (e) Find out the largest SAR result on these testing positions of each band
- (f) Measure SAR results for other channels in worst SAR testing position if the reported SAR of highest power channel is larger than 0.8 W/kg

According to the test standard, the recommended procedure for assessing the peak spatial-average SAR value consists of the following steps:

- (a) Power reference measurement
- (b) Area scan
- (c) Zoom scan
- (d) Power drift measurement

### 9.1 Spatial Peak SAR Evaluation

The procedure for spatial peak SAR evaluation has been implemented according to the test standard. It can be conducted for 1g and 10g, as well as for user-specific masses. The DASY software includes all numerical procedures necessary to evaluate the spatial peak SAR value.

The base for the evaluation is a "cube" measurement. The measured volume must include the 1g and 10g cubes with the highest averaged SAR values. For that purpose, the center of the measured volume is aligned to the interpolated peak SAR value of a previously performed area scan.

The entire evaluation of the spatial peak values is performed within the post-processing engine (SEMCAD). The system always gives the maximum values for the 1g and 10g cubes. The algorithm to find the cube with highest averaged SAR is divided into the following stages:

- (a) Extraction of the measured data (grid and values) from the Zoom Scan
- (b) Calculation of the SAR value at every measurement point based on all stored data (A/D values and measurement parameters)
- (c) Generation of a high-resolution mesh within the measured volume
- (d) Interpolation of all measured values from the measurement grid to the high-resolution grid
- (e) Extrapolation of the entire 3-D field distribution to the phantom surface over the distance from sensor to surface
- (f) Calculation of the averaged SAR within masses of 1g and 10g

### 9.2 Power Reference Measurement

The Power Reference Measurement and Power Drift Measurements are for monitoring the power drift of the device under test in the batch process. The minimum distance of probe sensors to surface determines the closest measurement point to phantom surface. This distance cannot be smaller than the distance of sensor calibration points to probe tip as defined in the probe properties.

### 9.3 Area Scan

The area scan is used as a fast scan in two dimensions to find the area of high field values, before doing a fine measurement around the hot spot. The sophisticated interpolation routines implemented in DASY software can find the maximum found in the scanned area, within a range of the global maximum. The range (in dB0 is specified in the standards for compliance testing. For example, a 2 dB range is required in IEEE standard 1528 and IEC 62209 standards, whereby 3 dB is a requirement when compliance is assessed in accordance with the ARIB standard (Japan), if only one zoom scan follows the area scan, then only the absolute maximum will be taken as reference. For cases where multiple maximums are detected, the number of zoom scans has to be increased accordingly.

Area scan parameters extracted from FCC KDB 865664 D01v01r04 SAR measurement 100 MHz to 6 GHz.

	$\leq 3$ GHz	$> 3$ GHz
Maximum distance from closest measurement point (geometric center of probe sensors) to phantom surface	$5 \pm 1$ mm	$\frac{1}{2} \cdot \delta \cdot \ln(2) \pm 0.5$ mm
Maximum probe angle from probe axis to phantom surface normal at the measurement location	$30^\circ \pm 1^\circ$	$20^\circ \pm 1^\circ$
Maximum area scan spatial resolution: $\Delta x_{Area}, \Delta y_{Area}$	$\leq 2$ GHz: $\leq 15$ mm $2 - 3$ GHz: $\leq 12$ mm	$3 - 4$ GHz: $\leq 12$ mm $4 - 6$ GHz: $\leq 10$ mm
	When the x or y dimension of the test device, in the measurement plane orientation, is smaller than the above, the measurement resolution must be $\leq$ the corresponding x or y dimension of the test device with at least one measurement point on the test device.	

### 9.4 Zoom Scan

Zoom scans are used to assess the peak spatial SAR values within a cubic averaging volume containing 1 gram and 10 gram of simulated tissue. The zoom scan measures points (refer to table below) within a cube whose base faces are centered on the maxima found in a preceding area scan job within the same procedure. When the measurement is done, the zoom scan evaluates the averaged SAR for 1 gram and 10 gram and displays these values next to the job's label.

Zoom scan parameters extracted from FCC KDB 865664 D01v01r04 SAR measurement 100 MHz to 6 GHz.

		≤ 3 GHz	> 3 GHz	
Maximum zoom scan spatial resolution: $\Delta x_{Zoom}$ , $\Delta y_{Zoom}$		$\leq 2$ GHz: $\leq 8$ mm 2 – 3 GHz: $\leq 5$ mm*	3 – 4 GHz: $\leq 5$ mm* 4 – 6 GHz: $\leq 4$ mm*	
Maximum zoom scan spatial resolution, normal to phantom surface	uniform grid: $\Delta z_{Zoom}(n)$	$\leq 5$ mm	3 – 4 GHz: $\leq 4$ mm 4 – 5 GHz: $\leq 3$ mm 5 – 6 GHz: $\leq 2$ mm	
	graded grid	$\Delta z_{Zoom}(1)$ : between 1 <sup>st</sup> two points closest to phantom surface	$\leq 4$ mm	3 – 4 GHz: $\leq 3$ mm 4 – 5 GHz: $\leq 2.5$ mm 5 – 6 GHz: $\leq 2$ mm
		$\Delta z_{Zoom}(n>1)$ : between subsequent points	$\leq 1.5 \cdot \Delta z_{Zoom}(n-1)$	
Minimum zoom scan volume	x, y, z	$\geq 30$ mm	3 – 4 GHz: $\geq 28$ mm 4 – 5 GHz: $\geq 25$ mm 5 – 6 GHz: $\geq 22$ mm	
Note: $\delta$ is the penetration depth of a plane-wave at normal incidence to the tissue medium; see draft standard IEEE P1528-2011 for details. * When zoom scan is required and the <i>reported</i> SAR from the <i>area scan based 1-g SAR estimation</i> procedures of KDB 447498 is $\leq 1.4$ W/kg, $\leq 8$ mm, $\leq 7$ mm and $\leq 5$ mm zoom scan resolution may be applied, respectively, for 2 GHz to 3 GHz, 3 GHz to 4 GHz and 4 GHz to 6 GHz.				

### 9.5 Volume Scan Procedures

The volume scan is used to assess overlapping SAR distributions for antennas transmitting in different frequency bands. It is equivalent to an oversized zoom scan used in standalone measurements. The measurement volume will be used to enclose all the simultaneous transmitting antennas. For antennas transmitting simultaneously in different frequency bands, the volume scan is measured separately in each frequency band. In order to sum correctly to compute the 1g aggregate SAR, the EUT remain in the same test position for all measurements and all volume scan use the same spatial resolution and grid spacing. When all volume scan were completed, the software, SEMCAD postprocessor can combine and subsequently superpose these measurement data to calculating the multiband SAR.

### 9.6 Power Drift Monitoring

All SAR testing is under the EUT install full charged battery and transmit maximum output power. In DASy measurement software, the power reference measurement and power drift measurement procedures are used for monitoring the power drift of EUT during SAR test. Both these procedures measure the field at a specified reference position before and after the SAR testing. The software will calculate the field difference in dB. If the power drifts more than 5%, the SAR will be retested.



**10. Test Equipment List**

Manufacturer	Name of Equipment	Type/Model	Serial Number	Calibration	
				Last Cal.	Due Date
SPEAG	750MHz System Validation Kit	D750V3	1087	2019/3/27	2022/3/24
SPEAG	835MHz System Validation Kit	D835V2	4d258	2020/5/7	2023/5/6
SPEAG	1750MHz System Validation Kit	D1750V2	1090	2019/3/27	2022/3/25
SPEAG	1900MHz System Validation Kit	D1900V2	5d170	2019/3/26	2022/3/24
SPEAG	2450MHz System Validation Kit	D2450V2	908	2019/3/25	2022/3/23
SPEAG	3500MHz System Validation Kit	D3500V2	1037	2020/11/25	2021/11/24
SPEAG	3700MHz System Validation Kit	D3700V2	1008	2020/11/25	2021/11/24
SPEAG	3900MHz System Validation Kit	D3900V2	1048	2020/5/14	2023/5/13
SPEAG	5000MHz System Validation Kit	D5GHzV2	1113	2019/9/24	2022/9/22
SPEAG	Data Acquisition Electronics	DAE4	1650	2021/6/9	2022/6/8
SPEAG	Dosimetric E-Field Probe	EX3DV4	3935	2021/4/29	2022/4/28
SPEAG	SAM Twin Phantom	SAM Twin	TP-1697	NCR	NCR
Testo	Hygrometer	608-H1	1241332126	2021/1/7	2022/1/6
SPEAG	Phone Positioner	N/A	N/A	NCR	NCR
Anritsu	Radio Communication Analyzer	MT8821C	6201432831	2021/4/13	2022/4/12
Agilent	ENA Series Network Analyzer	E5071C	MY46106933	2021/7/31	2022/7/30
SPEAG	Dielectric Probe Kit	DAK-3.5	1144	2020/12/2	2021/12/1
Anritsu	Vector Signal Generator	MG3710A	6201682672	2021/1/7	2022/1/6
Rohde & Schwarz	Power Meter	NRVD	102081	2021/8/12	2022/8/11
Rohde & Schwarz	Power Sensor	NRV-Z5	100538	2021/8/12	2022/8/11
Rohde & Schwarz	Power Sensor	NRV-Z5	100539	2021/8/12	2022/8/11
R&S	CBT BLUETOOTH TESTER	CBT	101246	2021/4/12	2022/4/11
EXA	Spectrum Analyzer	FSV7	101632	2021/1/7	2022/1/6
FLUKE	DIGITAC THERMOMETER	51II	97240029	2021/8/13	2022/8/12
BONN	POWER AMPLIFIER	BLMA 0830-3	087193A	Note 1	
BONN	POWER AMPLIFIER	BLMA 2060-2	087193B	Note 1	
Agilent	Dual Directional Coupler	778D	20500	Note 1	
Agilent	Dual Directional Coupler	11691D	MY48151020	Note 1	
ARRA	Power Divider	A3200-2	N/A	Note 1	
MCL	Attenuation1	BW-S10W5+	N/A	Note 1	
MCL	Attenuation2	BW-S10W5+	N/A	Note 1	
MCL	Attenuation3	BW-S10W5+	N/A	Note 1	

**Note:**

1. Prior to system verification and validation, the path loss from the signal generator to the system check source and the power meter, which includes the amplifier, cable, attenuator and directional coupler, was measured by the network analyzer. The reading of the power meter was offset by the path loss difference between the path to the power meter and the path to the system check source to monitor the actual power level fed to the system check
2. Referring to KDB 865664 D01v01r04, the dipole calibration interval can be extended to 3 years with justification. The dipoles are also not physically damaged, or repaired during the interval.
3. The justification data of dipole can be found in appendix C. The return loss is < -20dB, within 20% of prior calibration, the impedance is within 5 ohm of prior calibration.

## 11. System Verification

### 11.1 Tissue Simulating Liquids

For the measurement of the field distribution inside the SAM phantom with DASY, the phantom must be filled with around 25 liters of homogeneous body tissue simulating liquid. For body SAR testing, the liquid height from the center of the flat phantom to the liquid top surface is larger than 15 cm, which is shown in Fig. 11.1.

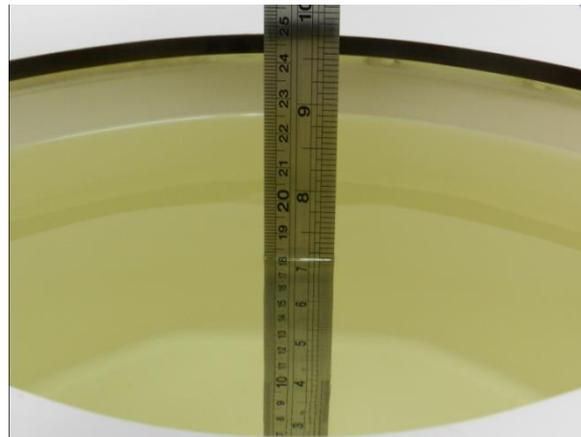

Fig 11.1 Photo of Liquid Height for Body SAR

**11.2 Tissue Verification**

The following tissue formulations are provided for reference only as some of the parameters have not been thoroughly verified. The composition of ingredients may be modified accordingly to achieve the desired target tissue parameters required for routine SAR evaluation.

Frequency (MHz)	Water (%)	Sugar (%)	Cellulose (%)	Salt (%)	Preventol (%)	DGBE (%)	Conductivity ( $\sigma$ )	Permittivity ( $\epsilon_r$ )
For Head								
750	41.1	57.0	0.2	1.4	0.2	0	0.89	41.9
835	40.3	57.9	0.2	1.4	0.2	0	0.90	41.5
1800, 1900, 2000	55.2	0	0	0.3	0	44.5	1.40	40.0
2450	55.0	0	0	0	0	45.0	1.80	39.2
2600	54.8	0	0	0.1	0	45.1	1.96	39.0

**Simulating Liquid for 5GHz, Manufactured by SPEAG**

Ingredients	(% by weight)
Water	64~78%
Mineral oil	11~18%
Emulsifiers	9~15%
Additives and Salt	2~3%

**<Tissue Dielectric Parameter Check Results>**

Frequency (MHz)	Tissue Type	Liquid Temp. (°C)	Conductivity ( $\sigma$ )	Permittivity ( $\epsilon_r$ )	Conductivity Target ( $\sigma$ )	Permittivity Target ( $\epsilon_r$ )	Delta ( $\sigma$ ) (%)	Delta ( $\epsilon_r$ ) (%)	Limit (%)	Date
750	Head	22.8	0.902	41.620	0.89	41.90	1.35	-0.67	±5	2021/9/25
835	Head	22.7	0.930	41.374	0.90	41.50	3.33	-0.30	±5	2021/9/27
1750	Head	22.7	1.351	40.014	1.37	40.10	-1.39	-0.21	±5	2021/9/29
1900	Head	22.9	1.432	39.780	1.40	40.00	2.29	-0.55	±5	2021/10/1
2450	Head	22.9	1.802	40.581	1.80	39.20	0.11	3.52	±5	2021/10/3
3500	Head	22.6	2.833	39.056	2.91	37.90	-2.65	3.05	±5	2021/10/5
3700	Head	22.7	3.024	38.720	3.12	37.70	-3.08	2.71	±5	2021/10/7
3900	Head	22.8	3.227	38.419	3.32	37.50	-2.80	2.45	±5	2021/10/9
5250	Head	22.7	4.597	35.936	4.71	35.90	-2.40	0.10	±5	2021/10/11
5750	Head	22.6	5.160	35.206	5.22	35.40	-1.15	-0.55	±5	2021/10/15

### 11.3 System Performance Check Results

Comparing to the original SAR value provided by SPEAG, the verification data should be within its specification of 10 %. Below table shows the target SAR and measured SAR after normalized to 1W input power. The table below indicates the system performance check can meet the variation criterion and the plots can be referred to Appendix A of this report.

Date	Frequency (MHz)	Tissue Type	Input Power (mW)	Dipole S/N	Probe S/N	DAE S/N	Measured 1g SAR (W/kg)	Targeted 1g SAR (W/kg)	Normalized 1g SAR (W/kg)	Deviation (%)
2021/9/25	750	Head	50	1087	3935	1650	0.402	8.36	8.04	-3.83
2021/9/27	835	Head	50	4d258	3935	1650	0.481	9.44	9.62	1.91
2021/9/29	1750	Head	50	1090	3935	1650	1.840	36.40	36.8	1.10
2021/10/1	1900	Head	50	5d170	3935	1650	2.010	39.00	40.2	3.08
2021/10/3	2450	Head	50	908	3935	1650	2.580	52.80	51.6	-2.27
2021/10/5	3500	Head	50	1037	3935	1650	3.310	68.00	66.2	-2.65
2021/10/7	3700	Head	50	1008	3935	1650	3.450	67.60	69	2.07
2021/10/9	3900	Head	50	1048	3935	1650	3.340	70.20	66.8	-4.84
2021/10/11	5250	Head	50	1113	3935	1650	4.260	80.50	85.2	5.84
2021/10/15	5750	Head	50	1113	3935	1650	4.110	80.00	82.2	2.75

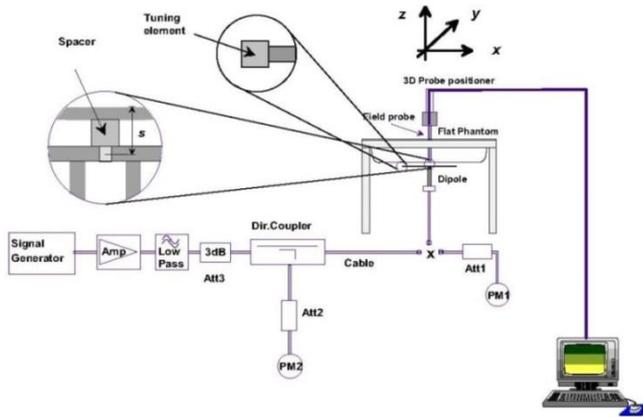

**Fig 11.3.1 System Performance Check Setup**



**Fig 11.3.2 Setup Photo**



## **12. RF Exposure Positions**

### **12.1 Wireless Router**

Some battery-operated handsets have the capability to transmit and receive user through simultaneous transmission of WIFI simultaneously with a separate licensed transmitter. The FCC has provided guidance in FCC KDB Publication 941225 D06 v02r01 where SAR test considerations for handsets ( $L \times W \geq 9 \text{ cm} \times 5 \text{ cm}$ ) are based on a composite test separation distance of 10mm from the front, back and edges of the device containing transmitting antennas within 2.5cm of their edges, determined from general mixed use conditions for this type of devices. Since the hotspot SAR results may overlap with the body-worn accessory SAR requirements, the more conservative configurations can be considered, thus excluding some body-worn accessory SAR tests.

When the user enables the personal wireless router functions for the handset, actual operations include simultaneous transmission of both the WIFI transmitter and another licensed transmitter. Both transmitters often do not transmit at the same transmitting frequency and thus cannot be evaluated for SAR under actual use conditions due to the limitations of the SAR assessment probes. Therefore, SAR must be evaluated for each frequency transmission and mode separately and spatially summed with the WIFI transmitter according to FCC KDB Publication 447498 D01v06 publication procedures. The "Portable Hotspot" feature on the handset was NOT activated during SAR assessments, to ensure the SAR measurements were evaluated for a single transmission frequency RF signal at a time.

#### **<EUT Setup Photos>**

Please refer to Appendix D for the test setup photos.

### **13. Conducted RF Output Power (Unit: dBm)**

The detailed conducted power table can refer to Appendix E.

#### **<LTE Conducted Power>**

##### **General Note:**

1. Anritsu MT8820C base station simulator was used to setup the connection with EUT; the frequency band, channel bandwidth, RB allocation configuration, modulation type are set in the base station simulator to configure EUT transmitting at maximum power and at different configurations which are requested to be reported to FCC, for conducted power measurement and SAR testing.
2. Per KDB 941225 D05v02r05, when a properly configured base station simulator is used for the SAR and power measurements, spectrum plots for each RB allocation and offset configuration is not required.
3. Per KDB 941225 D05v02r05, start with the largest channel bandwidth and measure SAR for QPSK with 1 RB allocation, using the RB offset and required test channel combination with the highest maximum output power for RB offsets at the upper edge, middle and lower edge of each required test channel.
4. Per KDB 941225 D05v02r05, 50% RB allocation for QPSK SAR testing follows 1RB QPSK allocation procedure.
5. Per KDB 941225 D05v02r05, for QPSK with 100% RB allocation, SAR is not required when the highest maximum output power for 100 % RB allocation is less than the highest maximum output power in 50% and 1 RB allocations and the highest reported SAR for 1 RB and 50% RB allocation are  $\leq 0.8$  W/kg. Otherwise, SAR is measured for the highest output power channel; and if the reported SAR is  $> 1.45$  W/kg, the remaining required test channels must also be tested.
6. Per KDB 941225 D05v02r05, 16QAM/64QAM/256QAM output power for each RB allocation configuration is  $>$  not  $\frac{1}{2}$  dB higher than the same configuration in QPSK and the reported SAR for the QPSK configuration is  $\leq 1.45$  W/kg; Per KDB 941225 D05v02r05, 16QAM/64QAM/256QAM SAR testing is not required.
7. Per KDB 941225 D05v02r05, smaller bandwidth output power for each RB allocation configuration is  $>$  not  $\frac{1}{2}$  dB higher than the same configuration in the largest supported bandwidth, and the reported SAR for the largest supported bandwidth is  $\leq 1.45$  W/kg; Per KDB 941225 D05v02r05, smaller bandwidth SAR testing is not required.
8. For LTE B4 / B5 the maximum bandwidth does not support three non-overlapping channels, per KDB 941225 D05v02r05, when a device supports overlapping channel assignment in a channel bandwidth configuration, the middle channel of the group of overlapping channels should be selected for testing.
9. LTE B4 SAR test was covered by B66; according to April 2015 TCB workshop, SAR test for overlapping LTE bands can be reduced if
  - a. the maximum output power, including tolerance, for the smaller band is  $\leq$  the larger band to qualify for the SAR test exclusion
  - b. the channel bandwidth and other operating parameters for the smaller band are fully supported by the larger band
10. According to 2017 TCB workshop, for 64 QAM and 16 QAM should be verified by checking the signal constellation with a call box to avoid incorrect maximum power levels due to MPR and other requirements associated with signal modulation, and the following figure is taken from the "Fundamental Measurement >> Modulation Analysis >> constellation" mode of the device connect to the MT8821C base station, therefore, the device 64QAM and 16QAM signal modulation are correct.

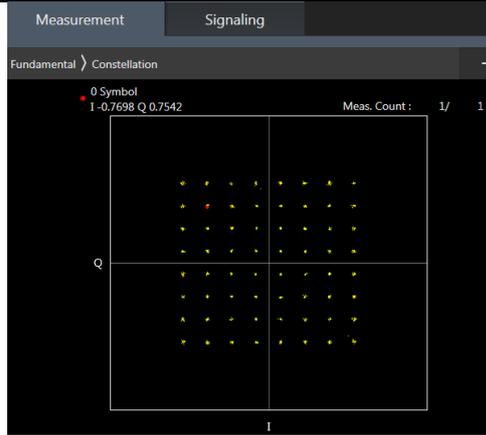

64QAM

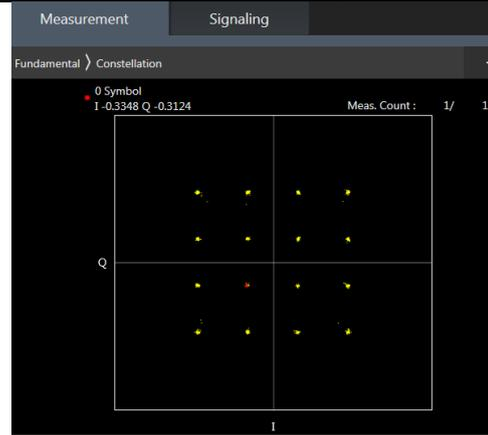

16QAM

<TDD LTE SAR Measurement>

TDD LTE configuration setup for SAR measurement

SAR was tested with a fixed periodic duty factor according to the highest transmission duty factor implemented for the device and supported by 3GPP.

- a. 3GPP TS 36.211 section 4.2 for Type 2 Frame Structure and Table 4.2-2 for uplink-downlink configurations
- b. "special subframe S" contains both uplink and downlink transmissions, it has been taken into consideration to determine the transmission duty factor according to the worst case uplink and downlink cyclic prefix requirements for UpPTS
- c. Establishing connections with base station simulators ensure a consistent means for testing SAR and recommended for evaluating SAR. The Anritsu MT8820C (firmware: #22.52#004) was used for LTE output power measurements and SAR testing.

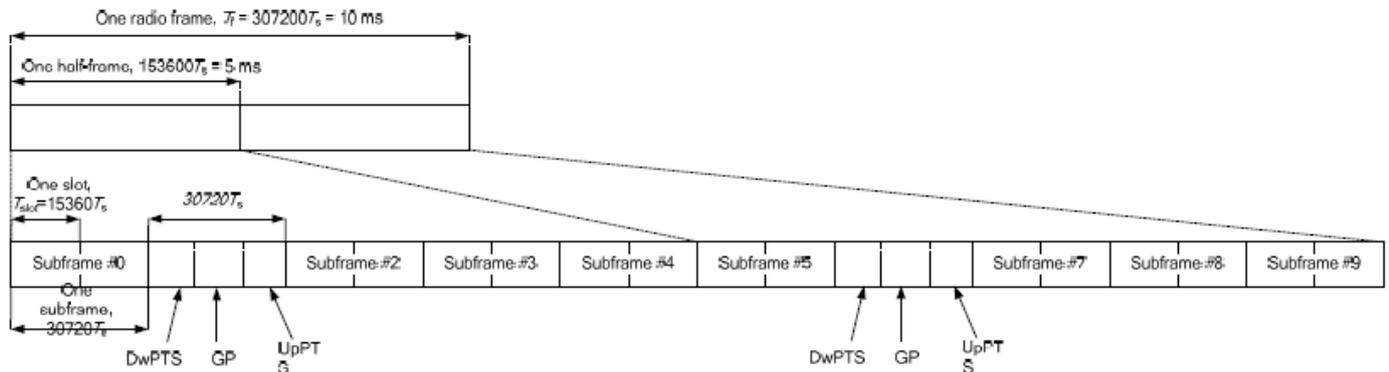

Figure 4.2-1: Frame structure type 2 (for 5 ms switch-point periodicity).

Table 4.2-2: Uplink-downlink configurations.

Uplink-downlink configuration	Downlink-to-Uplink Switch-point periodicity	Subframe number									
		0	1	2	3	4	5	6	7	8	9
0	5 ms	D	S	U	U	U	D	S	U	U	U
1	5 ms	D	S	U	U	D	D	S	U	U	D
2	5 ms	D	S	U	D	D	D	S	U	D	D
3	10 ms	D	S	U	U	U	D	D	D	D	D
4	10 ms	D	S	U	U	D	D	D	D	D	D
5	10 ms	D	S	U	D	D	D	D	D	D	D
6	5 ms	D	S	U	U	U	D	S	U	U	D

**Table 4.2-1: Configuration of special subframe (lengths of DwPTS/GP/UpPTS).**

Special subframe configuration	Normal cyclic prefix in downlink			Extended cyclic prefix in downlink		
	DwPTS	UpPTS		DwPTS	UpPTS	
		Normal cyclic prefix in uplink	Extended cyclic prefix in uplink		Normal cyclic prefix in uplink	Extended cyclic prefix in uplink
0	$6592 \cdot T_s$	$2192 \cdot T_s$	$2560 \cdot T_s$	$7680 \cdot T_s$	$2192 \cdot T_s$	$2560 \cdot T_s$
1	$19760 \cdot T_s$			$20480 \cdot T_s$		
2	$21952 \cdot T_s$			$23040 \cdot T_s$		
3	$24144 \cdot T_s$			$25600 \cdot T_s$		
4	$26336 \cdot T_s$			$7680 \cdot T_s$		
5	$6592 \cdot T_s$	$4384 \cdot T_s$	$5120 \cdot T_s$	$20480 \cdot T_s$	$4384 \cdot T_s$	$5120 \cdot T_s$
6	$19760 \cdot T_s$			$23040 \cdot T_s$		
7	$21952 \cdot T_s$			$12800 \cdot T_s$		
8	$24144 \cdot T_s$			-		
9	$13168 \cdot T_s$			-		

Special subframe ( $30720 \cdot T_s$ ): Normal cyclic prefix in downlink (UpPTS)			
	Special subframe configuration	Normal cyclic prefix in uplink	Extended cyclic prefix in uplink
Uplink duty factor in one special subframe	0~4	7.13%	8.33%
	5~9	14.3%	16.7%

Special subframe( $30720 \cdot T_s$ ): Extended cyclic prefix in downlink (UpPTS)			
	Special subframe configuration	Normal cyclic prefix in uplink	Extended cyclic prefix in uplink
Uplink duty factor in one special subframe	0~3	7.13%	8.33%
	4~7	14.3%	16.7%

The highest duty factor is resulted from:

- i. uplink-downlink configuration: 0. In a half-frame consisted of 5 subframes, uplink operation is in 3 uplink subframes and 1 special subframe.
- ii. special subframe configuration: 5-9 for normal cyclic prefix in downlink, 4-7 for extended cyclic prefix in downlink
- iii. for special subframe with extended cyclic prefix in uplink, the total uplink duty factor in one half-frame is:  $(3+0.167)/5 = 63.3\%$
- iv. for special subframe with normal cyclic prefix in uplink, the total uplink duty factor in one half-frame is:  $(3+0.143)/5 = 62.9\%$
- v. For SAR measurement the duty cycle 1:1.59 (62.9 %) was used perform testing.
- vi. Considering the theoretical duty cycle of 63.3% for extended cyclic prefix in the uplink, and the theoretical duty cycle of 62.9% for normal cyclic prefix in uplink, a scaling factor of extended cyclic prefix  $63.3\%/62.9\% = 1.006$  is applied to scale-up the measured SAR result. The scaled TDD LTE SAR = (measured SAR) \* (scaling factor for extended cyclic prefix).



<LTE Carrier Aggregation>

General Note:

1. This device supports Carrier Aggregation on downlink for inter and intra band. For the device supports bands and bandwidths and configurations are provided as follow table was according to 3GPP.
2. In applying the existing power measurement procedures of KDB 941225 D05A for DL CA SAR test exclusion, only the subset with the largest number of combinations of frequency bands and CCs in each row need combination, and for this device that all the configurations were choose to power measurement.
3. All permutations exist, no restrictions on Pcell & Scell combinations but only LTE Band 46 is limited to Scell.
4. The gray color table is covered by other combinations and no need to verify power.

2CC Downlink Carrier Aggregation	3CC Downlink Carrier Aggregation	4CC Downlink Carrier Aggregation	5CC Downlink Carrier Aggregation	6CC Downlink Carrier Aggregation	7CC Downlink Carrier Aggregation
13A_66A	2A-2A-4A	2A-2A-4A-4A	2A-2A-5A-66A-66A	2A-46A-48D-66A	2A-46C-48D-66A
2A-2A	2A-2A-5A	2A-2A-4A-5A	2A-2A-5A-66B	2A-46C-48C-66A	2A-46C-48E
2A_4A	2A-2A-13A	2A-2A-5A-66A	2A-2A-5A-66C	2A-46D-48A-66A	2A-46D-48C-66A
2A_66A	2A-2A-66A	2A-2A-13A-66A	2A-5B-66B	13A-48E-66A	2A-46E-48A-66A
2A_5A	2A-4A-4A	2A-2A-66A-66A	2A-5B-66C	2A-48E-66A	2A-46E-48C
4A_5A	2A-4A-5A	2A-2A-66B	2A-2A-13A-66A-66A		2A-46E-66A-66A
5A_66A	2A-4A-13A	2A-2A-66C	2A-13A-66A-66B		46C-48E-66A
4A_4A	2A-5A-66A	2A-4A-4A-5A	2A-5B-66A-66A		46E-48C-66A
5B	2A-5B	2A-4A-5B	2A-46A-46D		
5A_5A	2A-13A-66A	2A-5A-66A-66A	2A-46E		
66A-66A	2A-66A-66A	2A-5A-66B	2A-2A-46D		
66B	2A-66B	2A-5A-66C	4A-46A-46D		
66C	2A-66C	2A-5B-66A	5A-46E		
5A-13A	4A-4A-5A	2A-13A-66A-66A	13A-46E		
2A-46A	4A-4A-13A	2A-13A-66B	46A-46D-66A		
4A-46A	4A-5B	2A-13A-66C	46E-66A		
13A-46A	5A-5A-66A	4A-4A-5B	2A-5A-46D		
5A-46A	5A-66A-66A	5A-5A-66A-66A	2A-13A-46D		
46A-66A	5A-66B	5A-5A-66B	2A-46D-66A		
2A-48A	5A-66C	5A-5A-66C	5A-46D-66A		
4A-48A	5B-66A	5B-66A-66A	13A-46D-66A		
13A-48A	13A-66A-66A	5B-66B	46D-66A-66A		
48A-66A	13A-66B	5B-66C	5B-46D		
48C	13A-66C	2A-66A-66A-66A	2A-46E-66A		
48A-48A	66A-66C	2A-46A-46C	2A-48E		
5A-48A	66A-66A-66A	2A-2A-46C	4A-48E		
	2A-46A-46A	5B-46C	13A-48A-48C-66A		
	2A-46C	2A-46D	13A-48A-48D		
	4A-46A-46A	4A-46A-46C	13A-48C-48C		
	4A-46C	4A-46D	13A-48D-66A		
	5A-46C	5A-46D	13A-48E		
	13A-46C	13A-46D	2A-13A-48A-48A-66A		
	46A-46A-66A	46A-46C-66A	2A-13A-48A-48C		
	46C-66A	46D-66A	2A-13A-48C-66A		
	2A-5A-46A	2A-5A-46C	2A-13A-48D		
	2A-13A-46A	2A-13A-46C	2A-48A-48C-66A		
	2A-46A-66A	2A-46C-66A	2A-48A-48D		
	5A-46A-66A	5A-46C-66A	2A-48C-48C		
	5B-46A	13A-46C-66A	2A-48D-66A		
	13A-46A-66A	48C-48C	48C-48C-66A		
	2A-48A-48A	48A-48D	48A-48C-66B		
	2A-48A-66A	2A-13A-48A-48A	48A-48C-66C		
	2A-48C	2A-13A-48A-66A	48A-48D-66A		
	4A-48C	2A-13A-48C	48C-48D		
	13A-48A-48A	2A-48A-48A-66A	48E-66A		



	13A-48A-66A	2A-48A-48C	2A-5A-48C-66A		
	13A-48C	2A-48C-66A	2A-5A-48D		
	48A-48A-66A	4A-48D	5A-48D-66A		
	48A-66A-66A	2A-48D			
	48A-66B	13A-48A-48A-66A			
	48A-66C	13A-48C-66A			
	48C-66A	13A-48A-66B			
	48D	13A-48A-66C			
	2A-13A-48A	13A-48A-48C			
	2A-5A-48A	13A-48D			
	5A-48A-66A	48A-48A-66A-66A			
	48A-48C	48A-48A-66B			
	5A-48C	48A-48A-66C			
		48A-48C-66A			
		48C-66A-66A			
		48D-66A			
		48E			
		48C-66B			
		48C-66C			
		2A-5A-48A-66A			
		2A-5A-48C			
		5A-48C-66A			
		5A-48D			

**LTE Carrier Aggregation Conducted Power (Downlink)**

- i. According to KDB941225 D05A v01r02, Uplink maximum output power measurement with downlink carrier aggregation active should be measured, using the highest output channel measured without downlink carrier aggregation, to confirm that uplink maximum output power with downlink carrier aggregation active remains within the specified tune-up tolerance limits and not more than ¼ dB higher than the maximum output measured without downlink carrier aggregation active.
- ii. Uplink maximum output power with downlink carrier aggregation active does not show more than ¼ dB higher than the maximum output power without downlink carrier aggregation active, therefore SAR evaluation with downlink carrier aggregation active can be excluded.
- iii. The device supports downlink seven carrier aggregation. For power measurement were control and acknowledge data is sent on uplink channels that operate identical to specifications when downlink carrier aggregation is inactive.
- iv. Selected highest measured power when downlink carrier aggregation is inactive for conducted power comparison with downlink carrier aggregation is active, to confirm that when downlink carrier aggregation is active uplink maximum output power remains within the specified tune-up tolerance limits and not more than ¼ dB higher than the maximum output power measured when downlink carrier aggregation inactive.
- v. For inter-band CA, the SCC selected highest bandwidth and near the middle of its transmission band. For SCC DL RB size and offset will base on the PCC corresponding RB allocation.
- vi. For non-contiguous intra-band CA, the SCC selected to provide maximum separation from the PCC and must remain fully within the downlink transmission band.
- vii. For Intra-band, contiguous CA, the downlink channels selected to perform the uplink power measurement must satisfy 3GPP channel spacing (5.4.1A of 3GPP TS 36.521 or equivalent) and channel bandwidth (5.4.2A) requirements.

$$\text{Nominal channel spacing} = \left\lceil \frac{BW_{\text{Channel}(1)} + BW_{\text{Channel}(2)} - 0.1|BW_{\text{Channel}(1)} - BW_{\text{Channel}(2)}|}{0.6} \right\rceil 0.3 \text{ [MHz]}$$

**LTE 4x4 MIMO (Downlink)**

This device supports downlink 4x4 MIMO operations for LTE Bands 2/4/48/66 only. Uplink transmission is limited to a single output stream. Power measurements were performed with downlink 4x4 MIMO active for the configuration with highest measured maximum conducted power with 4x4 downlink MIMO inactive measured among the channel bandwidth, modulation, and RB combinations in each frequency band.

Per FCC Guidance, SAR for downlink 4x4 MIMO was not needed since the maximum average output power in 4x4 downlink MIMO mode was not > 0.25 dB higher than the maximum output power with downlink 4x4 MIMO inactive. When carrier aggregation is applicable, power measurements were performed with the downlink carrier aggregation and 4x4 DL MIMO active for the configuration with highest measured maximum conducted power with downlink carrier aggregation inactive measured among the channel bandwidth, modulation, and RB combinations in each frequency band.

4X4 MIMO	Band
	LTE Band2/4/48/66

**LTE Carrier Aggregation Conducted Power (Uplink)**

**<Intra-band>**

2CC Uplink Carrier Aggregation					
Number	Intra Band UL CA	Ant No.	Ant No.	Ant No.	Ant No.
1	5B	B5-ANT0	-	-	-
2	66B	B66-ANT0	B66-ANT1	B66-ANT2	B66-ANT3
3	66C	B66-ANT0	B66-ANT1	B66-ANT2	B66-ANT3
4	48C	B48-ANT4	B48-ANT3	B48-ANT5	B48-ANT2

**General Note:**

- i. The device supports intra-band uplink carrier aggregation for LTE B5/B48/B66 with a maximum of two 20MHz component carriers. For intra band contiguous carrier aggregation scenarios, 3GPP 36.101 table 6.2.2A-1 specifies that the aggregate maximum allowed output power is equivalent to the single carrier scenario. 3GPP 36.101 6.2.3A allows for several dB of MPR to be applied when not-contiguous RB allocation is implemented. The conducted power and MPR setting in this device are permanently implemented pre 3GPP requirement.
- ii. The device supports uplink carrier aggregation with a maximum of two 20MHz component carriers. For intra band contiguous carrier aggregation scenarios, 3GPP 36.101 table 6.2.2A-1 specifies that the aggregate maximum allowed output power is equivalent to the single carrier scenario. 3GPP 36.101 6.2.3A allows for several dB of MPR to be applied when not-contiguous RB allocation is implemented. The conducted power and MPR setting in this device are permanently implemented pre the 3GPP requirement.
- iii. According TCB workshop, the output power with uplink CA active was measured for the configuration with the highest reported SAR with single carrier for each exposure condition. The power was measured with wideband signal integration over both component carriers.
- iv. According TCB workshop, the output power with uplink CA active was measured for the configuration with the highest reported SAR with single carrier for each exposure condition. The power was measured with wideband signal integration over both component carriers.
- v. Additional SAR measurement for LTE UL CA with other DL CA combinations active were not required since the maximum output power for this configuration was not > 0.25dB higher than the maximum output power for UL CA active.
- vi. LTE CA 66B test was covered by 66C, therefore, SAR was only assessed for 66C.



<Inter-band>

2CC Uplink Carrier Aggregation			
Number	Inter Band UL CA List	Ant No.	Ant No.
1	2A-4A	PCC/B2/ANT6	SCC/B4/ANT0/ANT1/AN2/ANT3
2	4A-2A	PCC/B4/ANT0/ANT1/AN2/ANT3	SCC/B2/ANT6
3	2A-5A	PCC/B2/ANT6	SCC/B5/ANT0
4	5A-2A	PCC/B5/ANT0	SCC/B2/ANT6
5	2A-13A	PCC/B2/ANT6	SCC/B13/ANT0
6	13A-2A	PCC/B13/ANT0	SCC/B2/ANT6
7	2A-66A	PCC/B2/ANT6	SCC/B66/ANT0/ANT1/AN2/ANT3
8	66A-2A	PCC/B66/ANT0/ANT1/AN2/ANT3	SCC/B2/ANT6
9	4A-5A	PCC/B4/ANT6	SCC/B5/ANT0
10	5A-4A	PCC/B5/ANT0	SCC/B4/ANT6
11	4A-13A	PCC/B4/ANT6	SCC/B13/ANT0
12	13A-4A	PCC/B13/ANT0	SCC/B4/ANT6
13	5A-66A	PCC/B5/ANT0	SCC/B66/ANT6
14	66A-5A	PCC/B66/ANT6	SCC/B5/ANT0
15	13A-66A	PCC/B13/ANT0	SCC/B66/ANT6
16	66A-13A	PCC/B66/ANT6	SCC/B13/ANT0

**General Note:**

1. According to October 2018 TCB workshop, uplink CA SAR test guidance as follows:
  - a. Provide the single uplink SAR values you have obtained for the relevant SAR configuration and frequency bands that employ inter-band uplink carrier aggregation.
  - b. If the single uplink 1g SAR values for each band are both less than 0.8W/kg and the algebraic summation of the 1g SAR values are less than 1.45W/kg no additional measurements need to be performed.
  - c. If one on the single uplink 1g SAR values is greater than 0.8W/kg, instead of algebraically summing the 1g SAR values, sum up the SAR distributions, similar to the enlarged zoom scan (volume scan) procedures found in FCC KDB publication 865664 D01 SAR measurement 100MHz to 6GHz V01r04
  - d. If the algebraic sum of the 1g SAR values is > 1.45W/kg additional measurements may have to be made. Submit a KDB inquiry for additional guidance.
2. Test positions and test channels used for the testing below are based on the standalone SAR result. When the UL CA active reduced by 3dB for each frequency bands, therefore power and SAR was estimated based on standalone results to performed sim-Tx analysis with WiFi.

### **5G NR Output Power (Unit: dBm)**

#### **General Note:**

1. 5G NR n2 / n5 / n66 / n77 is NSA and SA mode.
2. For 5G NR test procedure was following step similar FCC KDB 941225 D05:
  - a. For DFT-OFDM and CP-OFDM output power measurement reduction, according to 38.101 maximum power reduction for power class2 and 3, the CP-OFDM mode will not higher than DFT-OFDM mode, therefore, similar FCC KDB 941225 D05 procedure for other modulation output power for each RB allocation configuration is > not ½ dB higher than the same configuration in DFT-s QPSK and the reported SAR for the DFT-s QPSK configuration is ≤ 1.45 W/kg; CP-OFDM testing is not required.
  - b. For DFT-OFDM output power measurement reduction, according to 38.101 maximum power reduction for power class2 and 3, for 16QAM/64QAM/256QAM and smaller bandwidth output power will spot check largest channel bandwidth worst RB configuration to ensure the 16QAM/64QAM/256QAM and smaller bandwidth output power will not ½ dB higher than the same configuration in the largest supported bandwidth.
  - c. SAR testing start with the largest channel bandwidth and measure SAR for QPSK with 1 RB allocation, using the RB offset and required test channel combination with the highest maximum output power for RB offsets at the upper edge, middle and lower edge of each required test channel
  - d. 50% RB allocation for QPSK SAR testing follows 1RB QPSK allocation procedure
  - e. QPSK with 100% RB allocation, SAR is not required when the highest maximum output power for 100 % RB allocation is less than the highest maximum output power in 50% and 1 RB allocations and the highest reported SAR for 1 RB and 50% RB allocation are ≤ 0.8 W/kg. Otherwise, SAR is measured for the highest output power channel; and if the reported SAR is > 1.45 W/kg, the remaining required test channels must also be tested
  - f. PI/2 BPSK/16QAM/64QAM/256QAM output powers according to 3GPP MPR will not ½ dB higher than the same configuration in QPSK, also reported SAR for the QPSK configuration is less than 1.45 W/kg, PI/2 BPSK/16QAM/64QAM/256QAM SAR testing are not required.
  - g. Smaller bandwidth output power for each RB allocation configuration for this device will not ½ dB higher than the same configuration in the largest supported bandwidth, and the reported SAR for the largest supported bandwidth is ≤ 1.45 W/kg, smaller bandwidth SAR testing is not required for this device
3. Due to test setup limitations, SAR testing for NR was performed using Factory Test Mode software to establish the connection and perform SAR with 100% transmission.
4. For 5G NR test, using FTM (Factory Test Mode) to perform SAR with default 100% transmission.
5. 5G NR supports CP-OFDM and DFT-s-OFDM modulation, for DFT-s-OFDM power is higher than CP-OFDM, so only show DFT-s-OFDM power table and chose DFT-s-OFDM to perform SAR testing.
6. For DFT-s-OFDM and CP-OFDM output power measurement reduction, according to 38.101 maximum power reduction for the CP-OFDM mode will not higher than DFT-s-OFDM mode, therefore, CP-OFDM measurement is unnecessary.
7. NSA and SA mode should perform SAR separately. For the maximum power of NSA mode is the same as SA total power level, so SA SAR can represent NSA mode SAR.
8. 5G NR NSA mode, the power level is the same as 5G NR SA mode, so 5G NR NSA mode and SA mode power table only show one time.
9. 5G NR NSA EN-DC mode, standalone SAR performed for 5G NR band with the maximum power, EN-DC SAR summed 5G NR standalone SAR and LTE standalone SAR , the result of EN-DC SAR is more conservatively.

<3GPP 38.101 MPR for EN-DC>

Table 6.2.2-1 Maximum power reduction (MPR) for power class 3

Modulation		MPR (dB)		
		Edge RB allocations	Outer RB allocations	Inner RB allocations
DFT-s-OFDM	Pi/2 BPSK	$\leq 3.5^1$	$\leq 1.2^1$	$\leq 0.2^1$
		$\leq 0.5^2$	$\leq 0.5^2$	0 <sup>2</sup>
	QPSK		$\leq 1$	0
	16 QAM		$\leq 2$	$\leq 1$
	64 QAM			
CP-OFDM	256 QAM		$\leq 2.5$	
	QPSK		$\leq 4.5$	
	16 QAM	$\leq 3$		$\leq 1.5$
	64 QAM	$\leq 3$		$\leq 2$
	256 QAM		$\leq 3.5$	
			$\leq 6.5$	

NOTE 1: Applicable for UE operating in TDD mode with Pi/2 BPSK modulation and UE indicates support for UE capability *powerBoosting-pi2BPSK* and if the IE *powerBoostPi2BPSK* is set to 1 and 40 % or less slots in radio frame are used for UL transmission for bands n40, n41, n77, n78 and n79. The reference power of 0 dB MPR is 26 dBm.

NOTE 2: Applicable for UE operating in FDD mode, or in TDD mode in bands other than n40, n41, n77, n78 and n79 with Pi/2 BPSK modulation and if the IE *powerBoostPi2BPSK* is set to 0 and if more than 40 % of slots in radio frame are used for UL transmission for bands n40, n41, n77, n78 and n79.

Table 6.2.2-2 Maximum power reduction (MPR) for power class 2

Modulation		MPR (dB)		
		Edge RB allocations	Outer RB allocations	Inner RB allocations
DFT-s-OFDM	Pi/2 BPSK	$\leq 3.5$	$\leq 0.5$	0
	QPSK	$\leq 3.5$	$\leq 1$	0
	16 QAM	$\leq 3.5$	$\leq 2$	$\leq 1$
	64 QAM	$\leq 3.5$		$\leq 2.5$
	256 QAM		$\leq 4.5$	
CP-OFDM	QPSK	$\leq 3.5$	$\leq 3$	$\leq 1.5$
	16 QAM	$\leq 3.5$	$\leq 3$	$\leq 2$
	64 QAM		$\leq 3.5$	
	256 QAM		$\leq 6.5$	

ENDC List	LTE Ant No.	NR Ant No.
DC_13A_n2A	B13/ANT0/TX0	N2/ANT6/TX1
DC_13A_n66A	B13/ANT0/TX0	N66/ANT6/TX1
DC_2A_n5A	B2/ANT6/TX0	N5/ANT0/TX0
DC_2A_n66A	B2/ANT0/TX0	N66/ANT6/TX1
DC_5A_n66A	B5/ANT0/TX0	N66/ANT6/TX1
DC_5A_n2A	B5/ANT0/TX0	N2/ANT6/TX1
DC_66A_n2A	B66/ANT6/TX1	N2/ANT0/TX0
DC_66A_n5A	B66/ANT6/TX1	N5/ANT0/TX0
DC_13A_n77A	B13/ANT0	N77/ANT4
DC_2A_n77A	B2/ANT0	N77/ANT4
DC_66A_n77A	B66/ANT0	N77/ANT4
DC_48A_n5A	B48/ANT4	N5/ANT0
DC_2A_n66A	B2/ANT1	N66/ANT0
DC_2A-46E-48A_n66A	B2/ANT1(B46 ANT3/B48 ANT4 only RX)	N66/ANT0
DC_5A_n77A	B5/ANT0	N77/ANT4
DC_48A_N66A	B48/ANT4	N66/ANT0

**<WLAN Conducted Power>**

**General Note:**

1. Per KDB 248227 D01v02r02, SAR test reduction is determined according to 802.11 transmission mode configurations and certain exposure conditions with multiple test positions. In the 2.4 GHz band, separate SAR procedures are applied to DSSS and OFDM configurations to simplify DSSS test requirements. For OFDM, in both 2.4 and 5 GHz bands, an initial test configuration must be determined for each standalone and aggregated frequency band, according to the transmission mode configuration with the highest maximum output power specified for production units to perform SAR measurements. If the same highest maximum output power applies to different combinations of channel bandwidths, modulations and data rates, additional procedures are applied to determine which test configurations require SAR measurement. When applicable, an initial test position may be applied to reduce the number of SAR measurements required for next to the ear, UMPC mini-tablet or hotspot mode configurations with multiple test positions.
2. For 2.4 GHz 802.11b DSSS, either the initial test position procedure for multiple exposure test positions or the DSSS procedure for fixed exposure position is applied; these are mutually exclusive. For 2.4 GHz and 5 GHz OFDM configurations, the initial test configuration is applied to measure SAR using either the initial test position procedure for multiple exposure test position configurations or the initial test configuration procedures for fixed exposure test conditions. Based on the reported SAR of the measured configurations and maximum output power of the transmission mode configurations that are not included in the initial test configuration, the subsequent test configuration and initial test position procedures are applied to determine if SAR measurements are required for the remaining OFDM transmission configurations. In general, the number of test channels that require SAR measurement is minimized based on maximum output power measured for the test sample(s).
3. For OFDM transmission configurations in the 2.4 GHz and 5 GHz bands, When the same maximum power is specified for multiple transmission modes in a frequency band, the largest channel bandwidth, lowest order modulation, lowest data rate and lowest order 802.11a/g/n/ac mode is used for SAR measurement, on the highest measured output power channel for each frequency band.
4. DSSS and OFDM configurations are considered separately according to the required SAR procedures. SAR is measured in the initial test position using the 802.11 transmission mode configuration required by the DSSS procedure or initial test configuration and subsequent test configuration(s) according to the OFDM procedures.18 The initial test position procedure is described in the following:
  - a. When the reported SAR of the initial test position is  $\leq 0.4$  W/kg, further SAR measurement is not required for the other test positions in that exposure configuration and 802.11 transmission mode combinations within the frequency band or aggregated band.
  - b. When the reported SAR of the test position is  $> 0.4$  W/kg, SAR is repeated for the 802.11 transmission mode configuration tested in the initial test position to measure the subsequent next closet/smallest test separation distance and maximum coupling test position on the highest maximum output power channel, until the report SAR is  $\leq 0.8$  W/kg or all required test position are tested.
  - c. For all positions/configurations, when the reported SAR is  $> 0.8$  W/kg, SAR is measured for these test positions/configurations on the subsequent next highest measured output power channel(s) until the reported SAR is  $\leq 1.2$  W/kg or all required channels are tested.
5. 802.11ax supports full tone size and partial tone size, for full tone size with higher power level, So only chose full tone size to perform SAR testing.



## **14. Antenna Location**

The detailed antenna location information can refer to SAR Test Setup Photos.

## 15. SAR Test Results

### General Note:

- Per KDB 447498 D01v06, the reported SAR is the measured SAR value adjusted for maximum tune-up tolerance.
  - Tune-up scaling Factor = tune-up limit power (mW) / EUT RF power (mW), where tune-up limit is the maximum rated power among all production units.
  - For SAR testing of BT/WLAN signal with non-100% duty cycle, the measured SAR is scaled-up by the duty cycle scaling factor which is equal to "1/(duty cycle)"
  - For WWAN: Reported SAR(W/kg)= Measured SAR(W/kg)\*Tune-up Scaling Factor
  - For BT/WLAN: Reported SAR(W/kg)= Measured SAR(W/kg)\* Duty Cycle scaling factor \* Tune-up scaling factor
  - For TDD LTE SAR measurement, the duty cycle 1:1.59 (62.9 %) was used perform testing and considering the theoretical duty cycle of 63.3% for extended cyclic prefix in the uplink, and the theoretical duty cycle of 62.9% for normal cyclic prefix in uplink, a scaling factor of extended cyclic prefix  $63.3\%/62.9\% = 1.006$  is applied to scale-up the measured SAR result. The Reported TDD LTE SAR = measured SAR (W/kg)\* Tune-up Scaling Factor\* scaling factor for extended cyclic prefix.
- Per KDB 447498 D01v06, for each exposure position, testing of other required channels within the operating mode of a frequency band is not required when the *reported* 1-g or 10-g SAR for the mid-band or highest output power channel is:
  - ≤ 0.8 W/kg or 2.0 W/kg, for 1-g or 10-g respectively, when the transmission band is ≤ 100 MHz
  - ≤ 0.6 W/kg or 1.5 W/kg, for 1-g or 10-g respectively, when the transmission band is between 100 MHz and 200 MHz
  - ≤ 0.4 W/kg or 1.0 W/kg, for 1-g or 10-g respectively, when the transmission band is ≥ 200 MHz
- Per KDB 865664 D01v01r04, for each frequency band, repeated SAR measurement is required only when the measured SAR is ≥0.8W/kg.
- The device implements Proximity sensors trigger reduced power for the power management for SAR compliance at different exposure conditions (body) and the details about the power management decision and sensor detection are provided in the operational description. And the device will invoke corresponding work scenarios power level base on frequency bands/antennas, which can refer to power table at appendix E.
- For UL inter-band CA LTE Band, when at EN-DC combination and UL Inter-Band CA, the power is same, so LTE EN-DC SAR can represent LTE UL Inter-Band CA SAR. Choose LTE EN-DC SAR result to do simultaneous transmission summation for LTE Inter Band UL CA.
- Referring to KDB 941225 D06 v02r01, when the overall device length and width are ≥ 9cm\*5cm, the test distance is 10 mm. SAR must be measured for all sides and surfaces with a transmitting antenna located within 25mm from that surface or edge.

### LTE Note:

- Per KDB 941225 D05v02r05, start with the largest channel bandwidth and measure SAR for QPSK with 1 RB allocation, using the RB offset and required test channel combination with the highest maximum output power for RB offsets at the upper edge, middle and lower edge of each required test channel.
- Per KDB 941225 D05v02r05, 50% RB allocation for QPSK SAR testing follows 1RB QPSK allocation procedure.
- Per KDB 941225 D05v02r05, for QPSK with 100% RB allocation, SAR is not required when the highest maximum output power for 100 % RB allocation is less than the highest maximum output power in 50% and 1 RB allocations and the highest reported SAR for 1 RB and 50% RB allocation are ≤ 0.8 W/kg. Otherwise, SAR is measured for the highest output power channel; and if the reported SAR is > 1.45 W/kg, the remaining required test channels must also be tested.
- Per KDB 941225 D05v02r05, 16QAM/64QAM/256QAM output power for each RB allocation configuration is > not ½ dB higher than the same configuration in QPSK and the reported SAR for the QPSK configuration is ≤ 1.45 W/kg; Per KDB 941225 D05v02r05, 16QAM/64QAM/256QAM SAR testing is not required.
- Per KDB 941225 D05v02r05, smaller bandwidth output power for each RB allocation configuration is > not ½ dB higher than the same configuration in the largest supported bandwidth, and the reported SAR for the largest supported bandwidth is ≤ 1.45 W/kg; Per KDB 941225 D05v02r05, smaller bandwidth SAR testing is not required.
- For LTE B4 / B5 the maximum bandwidth does not support three non-overlapping channels, per KDB 941225 D05v02r05, when a device supports overlapping channel assignment in a channel bandwidth configuration, the middle channel of the group of overlapping channels should be selected for testing.
- LTE B4 SAR test was covered by LTE B66; according to April 2015 TCB workshop, SAR test for overlapping LTE bands can be reduced if
  - the maximum output power, including tolerance, for the smaller band is ≤ the larger band to qualify for the SAR test exclusion
  - the channel bandwidth and other operating parameters for the smaller band are fully supported by the larger band

**5G NR Note:**

1. For 5G NR test procedure was following step similar FCC KDB 941225 D05:
  - a. SAR testing start with the largest channel bandwidth and measure SAR for QPSK with 1 RB allocation, using the RB offset and required test channel combination with the highest maximum output power for RB offsets at the upper edge, middle and lower edge of each required test channel.
  - b. 50% RB allocation for QPSK SAR testing follows 1RB QPSK allocation procedure
  - c. QPSK with 100% RB allocation, SAR is not required when the highest maximum output power for 100 % RB allocation is less than the highest maximum output power in 50% and 1 RB allocations and the highest reported SAR for 1 RB and 50% RB allocation are  $\leq 0.8$  W/kg. Otherwise, SAR is measured for the highest output power channel; and if the reported SAR is  $> 1.45$  W/kg, the remaining required test channels must also be tested.
  - d. PI/2 BPSK/16QAM/64QAM/256QAM output powers according to 3GPP MPR will not  $\frac{1}{2}$  dB higher than the same configuration in PI/2 BPSK, also reported SAR for the QPSK configuration is less than 1.45 W/kg, PI/2 BPSK/16QAM/64QAM/256QAM SAR testing are not required.
  - e. Smaller bandwidth output power for each RB allocation configuration for this device will not  $\frac{1}{2}$  dB higher than the same configuration in the largest supported bandwidth, and the reported SAR for the largest supported bandwidth is  $\leq 1.45$  W/kg, smaller bandwidth SAR testing is not required for this device
  - f. For 5G FR1 n5/n77 the maximum bandwidth does not support three non-overlapping channels, when a device supports overlapping channel assignment in a channel bandwidth configuration, the middle channel of the group of overlapping channels should be selected for testing.
  - g. 5G NR n77 located antenna 4 and antenna 5, only MIMO state, antenna 5 can work. Other situation, antenna 5 is not work. This test report, n77 perform SAR testing at antenna 5 is mainly for MIMO mode.
  - h. 5G NR n77 supports MIMO mode, MIMO power have been verified and MIMO total power is the less than SISO power. Summed SISO SAR can represent MIMO SAR conservatively.

**WLAN Note:**

1. Per KDB 248227 D01v02r02, for 2.4GHz 802.11g/n SAR testing is not required when the highest reported SAR for DSSS is adjusted by the ratio of OFDM to DSSS specified maximum output power and the adjusted SAR is  $\leq 1.2$  W/kg.
2. When the reported SAR of the test position is  $> 0.4$  W/kg, SAR is repeated for the 802.11 transmission mode configuration tested in the initial test position to measure the subsequent next closet/smallest test separation distance and maximum coupling test position on the highest maximum output power channel, until the report SAR is  $\leq 0.8$  W/kg or all required test position are tested.
3. For all positions / configurations, when the reported SAR is  $> 0.8$  W/kg, SAR is measured for these test positions / configurations on the subsequent next highest measured output power channel(s) until the reported SAR is  $\leq 1.2$  W/kg or all required channels are tested.
4. During SAR testing the WLAN transmission was verified using a spectrum analyzer.



15.1 Body SAR

<FDD LTE SAR>

Plot No.	Band	BW (MHz)	Modulation	RB Size	RB offset	Test Position	Gap (mm)	Antenna	Power Reduction	Ch.	Freq. (MHz)	Average Power (dBm)	Tune-Up Limit (dBm)	Tune-up Scaling Factor	Power Drift (dB)	Measured 1g SAR (W/kg)	Reported 1g SAR (W/kg)
	LTE Band 2	20M	QPSK	1	0	Front	10mm	Ant 0	Sensor On	18900	1880	20.03	21.00	1.250	0.09	0.359	0.449
	LTE Band 2	20M	QPSK	50	0	Front	10mm	Ant 0	Sensor On	18900	1880	19.91	21.00	1.285	0.1	0.288	0.370
	LTE Band 2	20M	QPSK	1	0	Back	10mm	Ant 0	Sensor On	18900	1880	20.03	21.00	1.250	-0.18	0.387	0.484
	LTE Band 2	20M	QPSK	50	0	Back	10mm	Ant 0	Sensor On	18900	1880	19.91	21.00	1.285	0.04	0.294	0.378
01	LTE Band 2	20M	QPSK	1	0	Left Side	10mm	Ant 0	Sensor On	18900	1880	20.03	21.00	1.250	0.05	0.788	0.985
	LTE Band 2_EN-DC	20M	QPSK	1	0	Left Side	10mm	Ant 0	Sensor On	18900	1880	16.93	18.00	1.279	0.03	0.371	0.475
	LTE Band 2	20M	QPSK	1	0	Left Side	10mm	Ant 0	Sensor On	18700	1860	19.80	21.00	1.318	0.02	0.744	0.981
	LTE Band 2	20M	QPSK	1	0	Left Side	10mm	Ant 0	Sensor On	19100	1900	19.77	21.00	1.327	0.01	0.741	0.984
	LTE Band 2	20M	QPSK	50	0	Left Side	10mm	Ant 0	Sensor On	18900	1880	19.91	21.00	1.285	-0.08	0.637	0.819
	LTE Band 2	20M	QPSK	50	0	Left Side	10mm	Ant 0	Sensor On	18700	1860	19.81	21.00	1.315	0.03	0.622	0.818
	LTE Band 2	20M	QPSK	50	0	Left Side	10mm	Ant 0	Sensor On	19100	1900	19.79	21.00	1.321	0.07	0.630	0.832
	LTE Band 2	20M	QPSK	100	0	Left Side	10mm	Ant 0	Sensor On	18900	1880	19.91	21.00	1.285	0.06	0.750	0.964
	LTE Band 2	20M	QPSK	1	0	Right Side	10mm	Ant 0	Sensor Off	18900	1880	22.80	24.00	1.318	0.13	0.005	0.007
	LTE Band 2	20M	QPSK	50	0	Right Side	10mm	Ant 0	Sensor Off	18900	1880	21.69	23.00	1.352	0.04	0.003	0.004
	LTE Band 2	20M	QPSK	1	0	Top Side	10mm	Ant 0	Sensor Off	18900	1880	22.80	24.00	1.318	0.03	0.139	0.183
	LTE Band 2	20M	QPSK	50	0	Top Side	10mm	Ant 0	Sensor Off	18900	1880	21.69	23.00	1.352	0.02	0.111	0.150
	LTE Band 2	20M	QPSK	1	0	Bottom Side	10mm	Ant 0	Sensor Off	18900	1880	22.80	24.00	1.318	-0.07	0.105	0.138
	LTE Band 2	20M	QPSK	50	0	Bottom Side	10mm	Ant 0	Sensor Off	18900	1880	21.69	23.00	1.352	0.17	0.083	0.112
	LTE Band 2	20M	QPSK	1	0	Front	21mm	Ant 0	Sensor Off	18900	1880	22.80	24.00	1.318	0.03	0.148	0.195
	LTE Band 2	20M	QPSK	1	0	Back	17mm	Ant 0	Sensor Off	18900	1880	22.80	24.00	1.318	-0.01	0.120	0.158
	LTE Band 2	20M	QPSK	1	0	Left Side	31mm	Ant 0	Sensor Off	18900	1880	22.80	24.00	1.318	0.09	0.095	0.125
	LTE Band 2	20M	QPSK	1	0	Front	10mm	Ant 6	Sensor Off	18900	1880	23.00	24.00	1.259	0.11	0.588	0.740
	LTE Band 2_EN-DC	20M	QPSK	1	0	Front	10mm	Ant 6	Sensor On	18900	1880	21.05	22.00	1.245	0.01	0.402	0.500
	LTE Band 2	20M	QPSK	50	0	Front	10mm	Ant 6	Sensor Off	18900	1880	22.12	23.00	1.225	0.03	0.519	0.636
	LTE Band 2	20M	QPSK	1	0	Back	10mm	Ant 6	Sensor Off	18900	1880	23.00	24.00	1.259	0.17	0.439	0.553
	LTE Band 2	20M	QPSK	50	0	Back	10mm	Ant 6	Sensor Off	18900	1880	22.12	23.00	1.225	-0.1	0.410	0.502
	LTE Band 2	20M	QPSK	1	0	Left Side	10mm	Ant6	Sensor Off	18900	1880	23.00	24.00	1.259	-0.05	0.047	0.059
	LTE Band 2	20M	QPSK	50	0	Left Side	10mm	Ant6	Sensor Off	18900	1880	22.12	23.00	1.225	0.06	0.039	0.048
	LTE Band 2	20M	QPSK	1	0	Right Side	10mm	Ant6	Sensor Off	18900	1880	23.00	24.00	1.259	-0.03	0.269	0.339
	LTE Band 2	20M	QPSK	50	0	Right Side	10mm	Ant6	Sensor Off	18900	1880	22.12	23.00	1.225	-0.16	0.226	0.277
	LTE Band 2	20M	QPSK	1	0	Top Side	10mm	Ant 6	Sensor Off	18900	1880	23.00	24.00	1.259	-0.06	0.376	0.473
	LTE Band 2	20M	QPSK	50	0	Top Side	10mm	Ant 6	Sensor Off	18900	1880	22.12	23.00	1.225	-0.06	0.328	0.402
	LTE Band 2	20M	QPSK	1	0	Bottom Side	10mm	Ant6	Sensor Off	18900	1880	23.00	24.00	1.259	0.18	0.003	0.004
	LTE Band 2	20M	QPSK	50	0	Bottom Side	10mm	Ant6	Sensor Off	18900	1880	22.12	23.00	1.225	0.01	0.001	0.001
	LTE Band 2	20M	QPSK	1	0	Front	17mm	Ant6	Sensor Off	18900	1880	23.00	24.00	1.259	0.01	0.192	0.242
	LTE Band 2	20M	QPSK	1	0	Front	10mm	Ant 1	Sensor Off	18900	1880	19.87	21.00	1.297	0.02	0.042	0.054
	LTE Band 2	20M	QPSK	50	0	Front	10mm	Ant 1	Sensor Off	18900	1880	18.99	20.00	1.262	0.01	0.033	0.042
	LTE Band 2	20M	QPSK	1	0	Back	10mm	Ant 1	Sensor Off	18900	1880	19.87	21.00	1.297	-0.08	0.055	0.071
	LTE Band 2	20M	QPSK	50	0	Back	10mm	Ant 1	Sensor Off	18900	1880	18.99	20.00	1.262	0.09	0.048	0.061
	LTE Band 2	20M	QPSK	1	0	Left Side	10mm	Ant 1	Sensor Off	18900	1880	19.87	21.00	1.297	0.04	0.006	0.008
	LTE Band 2	20M	QPSK	50	0	Left Side	10mm	Ant 1	Sensor Off	18900	1880	18.99	20.00	1.262	0.01	0.003	0.004
	LTE Band 2	20M	QPSK	1	0	Right Side	10mm	Ant 1	Sensor Off	18900	1880	19.87	21.00	1.297	0.08	0.045	0.058
	LTE Band 2	20M	QPSK	50	0	Right Side	10mm	Ant 1	Sensor Off	18900	1880	18.99	20.00	1.262	-0.05	0.039	0.049
	LTE Band 2	20M	QPSK	1	0	Top Side	10mm	Ant 1	Sensor Off	18900	1880	19.87	21.00	1.297	0.07	0.012	0.016
	LTE Band 2	20M	QPSK	50	0	Top Side	10mm	Ant 1	Sensor Off	18900	1880	18.99	20.00	1.262	0.06	0.010	0.013
	LTE Band 2	20M	QPSK	1	0	Bottom Side	10mm	Ant 1	Sensor Off	18900	1880	19.87	21.00	1.297	-0.05	0.013	0.017
	LTE Band 2	20M	QPSK	50	0	Bottom Side	10mm	Ant 1	Sensor Off	18900	1880	18.99	20.00	1.262	0.07	0.012	0.015
	LTE Band 2	20M	QPSK	1	0	Front	10mm	Ant 2	Sensor Off	18900	1880	22.18	23.00	1.208	0.09	0.228	0.275
	LTE Band 2	20M	QPSK	50	0	Front	10mm	Ant 2	Sensor Off	18900	1880	21.22	22.00	1.197	0.04	0.196	0.235
	LTE Band 2	20M	QPSK	1	0	Back	10mm	Ant 2	Sensor Off	18900	1880	22.18	23.00	1.208	0.01	0.264	0.319



# FCC SAR Test Report

Report No. : FA182710

	LTE Band 2	20M	QPSK	50	0	Back	10mm	Ant 2	Sensor Off	18900	1880	21.22	22.00	1.197	-0.18	0.222	0.266
	LTE Band 2	20M	QPSK	1	0	Left Side	10mm	Ant 2	Sensor Off	18900	1880	22.18	23.00	1.208	0.04	0.003	0.004
	LTE Band 2	20M	QPSK	50	0	Left Side	10mm	Ant 2	Sensor Off	18900	1880	21.22	22.00	1.197	0.03	0.037	0.044
	LTE Band 2	20M	QPSK	1	0	Right Side	10mm	Ant 2	Sensor Off	18900	1880	22.18	23.00	1.208	0.06	0.011	0.013
	LTE Band 2	20M	QPSK	50	0	Right Side	10mm	Ant 2	Sensor Off	18900	1880	21.22	22.00	1.197	-0.16	0.009	0.011
	LTE Band 2	20M	QPSK	1	0	Top Side	10mm	Ant 2	Sensor Off	18900	1880	22.18	23.00	1.208	-0.06	0.021	0.025
	LTE Band 2	20M	QPSK	50	0	Top Side	10mm	Ant 2	Sensor Off	18900	1880	21.22	22.00	1.197	-0.03	0.017	0.020
	LTE Band 2	20M	QPSK	1	0	Bottom Side	10mm	Ant 2	Sensor Off	18900	1880	22.18	23.00	1.208	-0.03	0.376	0.454
	LTE Band 2	20M	QPSK	50	0	Bottom Side	10mm	Ant 2	Sensor Off	18900	1880	21.22	22.00	1.197	-0.18	0.356	0.426
	LTE Band 2	20M	QPSK	1	0	Front	10mm	Ant 3	Sensor Off	18900	1880	20.67	21.00	1.079	-0.01	0.450	0.486
	LTE Band 2	20M	QPSK	50	0	Front	10mm	Ant 3	Sensor Off	18900	1880	19.75	20.00	1.059	0.07	0.329	0.348
	LTE Band 2	20M	QPSK	1	0	Back	10mm	Ant 3	Sensor Off	18900	1880	20.67	21.00	1.079	-0.05	0.193	0.208
	LTE Band 2	20M	QPSK	50	0	Back	10mm	Ant 3	Sensor Off	18900	1880	19.75	20.00	1.059	-0.05	0.165	0.175
	LTE Band 2	20M	QPSK	1	0	Left Side	10mm	Ant 3	Sensor Off	18900	1880	20.67	21.00	1.079	0.06	0.343	0.370
	LTE Band 2	20M	QPSK	50	0	Left Side	10mm	Ant 3	Sensor Off	18900	1880	19.75	20.00	1.059	-0.03	0.296	0.314
	LTE Band 2	20M	QPSK	1	0	Right Side	10mm	Ant 3	Sensor Off	18900	1880	20.67	21.00	1.079	-0.16	0.057	0.061
	LTE Band 2	20M	QPSK	50	0	Right Side	10mm	Ant 3	Sensor Off	18900	1880	19.75	20.00	1.059	-0.06	0.046	0.049
	LTE Band 2	20M	QPSK	1	0	Top Side	10mm	Ant 3	Sensor Off	18900	1880	20.67	21.00	1.079	-0.06	0.031	0.033
	LTE Band 2	20M	QPSK	50	0	Top Side	10mm	Ant 3	Sensor Off	18900	1880	19.75	20.00	1.059	-0.16	0.019	0.020
	LTE Band 2	20M	QPSK	1	0	Bottom Side	10mm	Ant 3	Sensor Off	18900	1880	20.67	21.00	1.079	0.18	0.002	0.002
	LTE Band 2	20M	QPSK	50	0	Bottom Side	10mm	Ant 3	Sensor Off	18900	1880	19.75	20.00	1.059	0.04	0.001	0.001
	LTE Band 5	10M	QPSK	1	0	Front	10mm	Ant 0	Sensor Off	20525	836.5	23.41	24.00	1.146	0.03	0.368	0.422
	LTE Band 5	10M	QPSK	25	0	Front	10mm	Ant 0	Sensor Off	20525	836.5	22.50	23.00	1.122	-0.17	0.295	0.331
02	LTE Band 5	10M	QPSK	1	0	Back	10mm	Ant 0	Sensor Off	20525	836.5	23.41	24.00	1.146	0.12	0.426	0.488
	LTE Band 5	10M	QPSK	1	0	Back	10mm	Ant 0	Sensor Off	20575+20476	841.5+831.6	23.22	24.00	1.197	0.1	0.376	0.450
	LTE Band 5	10M	QPSK	25	0	Back	10mm	Ant 0	Sensor Off	20525	836.5	22.50	23.00	1.122	0.01	0.343	0.385
	LTE Band 5	10M	QPSK	1	0	Left Side	10mm	Ant 0	Sensor Off	20525	836.5	23.41	24.00	1.146	0.08	0.076	0.087
	LTE Band 5	10M	QPSK	25	0	Left Side	10mm	Ant 0	Sensor Off	20525	836.5	22.50	23.00	1.122	0.02	0.064	0.072
	LTE Band 5	10M	QPSK	1	0	Right Side	10mm	Ant 0	Sensor Off	20525	836.5	23.41	24.00	1.146	0.06	0.003	0.003
	LTE Band 5	10M	QPSK	25	0	Right Side	10mm	Ant 0	Sensor Off	20525	836.5	22.50	23.00	1.122	-0.16	0.001	0.001
	LTE Band 5	10M	QPSK	1	0	Top Side	10mm	Ant 0	Sensor Off	20525	836.5	23.41	24.00	1.146	0.18	0.172	0.197
	LTE Band 5	10M	QPSK	25	0	Top Side	10mm	Ant 0	Sensor Off	20525	836.5	22.50	23.00	1.122	0.04	0.137	0.154
	LTE Band 5	10M	QPSK	1	0	Bottom Side	10mm	Ant 0	Sensor Off	20525	836.5	23.41	24.00	1.146	0.04	0.157	0.180
	LTE Band 5	10M	QPSK	25	0	Bottom Side	10mm	Ant 0	Sensor Off	20525	836.5	22.50	23.00	1.122	-0.04	0.127	0.142
	LTE Band 5	10M	QPSK	1	0	Front	10mm	Ant 1	Sensor Off	20525	836.5	23.20	24.00	1.202	0.11	0.255	0.307
	LTE Band 5	10M	QPSK	25	0	Front	10mm	Ant 1	Sensor Off	20525	836.5	22.34	23.00	1.164	0.07	0.262	0.305
	LTE Band 5	10M	QPSK	1	0	Back	10mm	Ant 1	Sensor Off	20525	836.5	23.20	24.00	1.202	-0.05	0.258	0.310
	LTE Band 5	10M	QPSK	25	0	Back	10mm	Ant 1	Sensor Off	20525	836.5	22.34	23.00	1.164	0.02	0.283	0.329
	LTE Band 5	10M	QPSK	1	0	Left Side	10mm	Ant 1	Sensor Off	20525	836.5	23.20	24.00	1.202	0.13	0.005	0.006
	LTE Band 5	10M	QPSK	25	0	Left Side	10mm	Ant 1	Sensor Off	20525	836.5	22.34	23.00	1.164	-0.18	0.002	0.002
	LTE Band 5	10M	QPSK	1	0	Right Side	10mm	Ant 1	Sensor Off	20525	836.5	23.20	24.00	1.202	0.06	0.003	0.004
	LTE Band 5	10M	QPSK	25	0	Right Side	10mm	Ant 1	Sensor Off	20525	836.5	22.34	23.00	1.164	-0.1	0.001	0.001
	LTE Band 5	10M	QPSK	1	0	Top Side	10mm	Ant 1	Sensor Off	20525	836.5	23.20	24.00	1.202	0.02	0.117	0.141
	LTE Band 5	10M	QPSK	25	0	Top Side	10mm	Ant 1	Sensor Off	20525	836.5	22.34	23.00	1.164	-0.05	0.140	0.163
	LTE Band 5	10M	QPSK	1	0	Bottom Side	10mm	Ant 1	Sensor Off	20525	836.5	23.20	24.00	1.202	0.05	0.106	0.127
	LTE Band 5	10M	QPSK	25	0	Bottom Side	10mm	Ant 1	Sensor Off	20525	836.5	22.34	23.00	1.164	0.05	0.115	0.134
03	LTE Band 13	10M	QPSK	1	0	Front	10mm	Ant 0	Sensor Off	23230	782	23.50	24.00	1.122	0.01	0.595	0.668
	LTE Band 13_EN-DC	10M	QPSK	1	0	Front	10mm	Ant 0	Sensor On	23230	782	21.24	22.00	1.191	0.02	0.271	0.323
	LTE Band 13	10M	QPSK	25	0	Front	10mm	Ant 0	Sensor Off	23230	782	22.41	23.00	1.146	0.03	0.488	0.559
	LTE Band 13	10M	QPSK	1	0	Back	10mm	Ant 0	Sensor Off	23230	782	23.50	24.00	1.122	0.05	0.487	0.546
	LTE Band 13	10M	QPSK	25	0	Back	10mm	Ant 0	Sensor Off	23230	782	22.41	23.00	1.146	0.04	0.414	0.474
	LTE Band 13	10M	QPSK	1	0	Left Side	10mm	Ant 0	Sensor Off	23230	782	23.50	24.00	1.122	-0.11	0.077	0.086
	LTE Band 13	10M	QPSK	25	0	Left Side	10mm	Ant 0	Sensor Off	23230	782	22.41	23.00	1.146	0.02	0.068	0.078
	LTE Band 13	10M	QPSK	1	0	Right Side	10mm	Ant 0	Sensor Off	23230	782	23.50	24.00	1.122	-0.03	0.008	0.009
	LTE Band 13	10M	QPSK	25	0	Right Side	10mm	Ant 0	Sensor Off	23230	782	22.41	23.00	1.146	-0.11	0.004	0.005
	LTE Band 13	10M	QPSK	1	0	Top Side	10mm	Ant 0	Sensor Off	23230	782	23.50	24.00	1.122	0.19	0.332	0.373



**FCC SAR Test Report**

**Report No. : FA182710**

	LTE Band 13	10M	QPSK	25	0	Top Side	10mm	Ant 0	Sensor Off	23230	782	22.41	23.00	1.146	-0.17	0.268	0.307
	LTE Band 13	10M	QPSK	1	0	Bottom Side	10mm	Ant 0	Sensor Off	23230	782	23.50	24.00	1.122	-0.02	0.297	0.333
	LTE Band 13	10M	QPSK	25	0	Bottom Side	10mm	Ant 0	Sensor Off	23230	782	22.41	23.00	1.146	0.17	0.245	0.281
	LTE Band 13	10M	QPSK	1	0	Front	21mm	Ant 0	Sensor Off	23230	782	23.50	24.00	1.122	0.01	0.321	0.360
	LTE Band 13	10M	QPSK	1	0	Front	10mm	Ant 1	Sensor Off	23230	782	23.27	24.00	1.183	0.04	0.115	0.136
	LTE Band 13	10M	QPSK	25	0	Front	10mm	Ant 1	Sensor Off	23230	782	22.47	23.00	1.130	0.17	0.094	0.106
	LTE Band 13	10M	QPSK	1	0	Back	10mm	Ant 1	Sensor Off	23230	782	23.27	24.00	1.183	-0.18	0.152	0.180
	LTE Band 13	10M	QPSK	25	0	Back	10mm	Ant 1	Sensor Off	23230	782	22.47	23.00	1.130	0.06	0.115	0.130
	LTE Band 13	10M	QPSK	1	0	Left Side	10mm	Ant 1	Sensor Off	23230	782	23.27	24.00	1.183	-0.18	0.003	0.004
	LTE Band 13	10M	QPSK	25	0	Left Side	10mm	Ant 1	Sensor Off	23230	782	22.47	23.00	1.130	0.04	0.003	0.003
	LTE Band 13	10M	QPSK	1	0	Right Side	10mm	Ant 1	Sensor Off	23230	782	23.27	24.00	1.183	0.06	0.010	0.012
	LTE Band 13	10M	QPSK	25	0	Right Side	10mm	Ant 1	Sensor Off	23230	782	22.47	23.00	1.130	-0.15	0.009	0.010
	LTE Band 13	10M	QPSK	1	0	Top Side	10mm	Ant 1	Sensor Off	23230	782	23.27	24.00	1.183	-0.03	0.060	0.071
	LTE Band 13	10M	QPSK	25	0	Top Side	10mm	Ant 1	Sensor Off	23230	782	22.47	23.00	1.130	0.07	0.061	0.069
	LTE Band 13	10M	QPSK	1	0	Bottom Side	10mm	Ant 1	Sensor Off	23230	782	23.27	24.00	1.183	0.08	0.048	0.057
	LTE Band 13	10M	QPSK	25	0	Bottom Side	10mm	Ant 1	Sensor Off	23230	782	22.47	23.00	1.130	-0.16	0.049	0.055
	LTE Band 66	20M	QPSK	1	0	Front	10mm	Ant 0	Sensor On	132322	1745	19.30	20.00	1.175	0.05	0.308	0.362
	LTE Band 66	20M	QPSK	50	0	Front	10mm	Ant 0	Sensor On	132322	1745	19.20	20.00	1.202	0.17	0.245	0.295
	LTE Band 66	20M	QPSK	1	0	Back	10mm	Ant 0	Sensor On	132322	1745	19.30	20.00	1.175	0.09	0.252	0.296
	LTE Band 66	20M	QPSK	50	0	Back	10mm	Ant 0	Sensor On	132322	1745	19.20	20.00	1.202	0.09	0.201	0.242
04	LTE Band 66	20M	QPSK	1	0	Left Side	10mm	Ant 0	Sensor On	132322	1745	19.30	20.00	1.175	0.02	0.878	1.032
	LTE Band 66_EN-DC	20M	QPSK	1	0	Left Side	10mm	Ant 0	Sensor On	132322	1745	16.20	17.00	1.202	-0.06	0.401	0.482
	LTE Band 66C	20M	QPSK	1	0	Left Side	10mm	Ant 0	Sensor On	132322+132124	1745+1725.2	19.28	20.00	1.180	0.11	0.843	0.995
	LTE Band 66	20M	QPSK	1	0	Left Side	10mm	Ant 0	Sensor On	132072	1720	19.18	20.00	1.208	0.05	0.851	1.028
	LTE Band 66	20M	QPSK	1	0	Left Side	10mm	Ant 0	Sensor On	132572	1770	18.88	20.00	1.294	0.04	0.788	1.020
	LTE Band 66	20M	QPSK	50	0	Left Side	10mm	Ant 0	Sensor On	132322	1745	19.20	20.00	1.202	-0.09	0.465	0.559
	LTE Band 66	20M	QPSK	100	0	Left Side	10mm	Ant 0	Sensor On	132322	1745	19.17	20.00	1.211	0.01	0.800	0.968
	LTE Band 66	20M	QPSK	1	0	Right Side	10mm	Ant 0	Sensor Off	132322	1745	23.20	24.00	1.202	-0.13	0.042	0.050
	LTE Band 66	20M	QPSK	50	0	Right Side	10mm	Ant 0	Sensor Off	132322	1745	22.10	23.00	1.230	0.08	0.013	0.016
	LTE Band 66	20M	QPSK	1	0	Top Side	10mm	Ant 0	Sensor Off	132322	1745	23.20	24.00	1.202	0.13	0.141	0.170
	LTE Band 66	20M	QPSK	50	0	Top Side	10mm	Ant 0	Sensor Off	132322	1745	22.10	23.00	1.230	0.01	0.114	0.140
	LTE Band 66	20M	QPSK	1	0	Bottom Side	10mm	Ant 0	Sensor Off	132322	1745	23.20	24.00	1.202	-0.18	0.263	0.316
	LTE Band 66	20M	QPSK	50	0	Bottom Side	10mm	Ant 0	Sensor Off	132322	1745	22.10	23.00	1.230	-0.12	0.210	0.258
	LTE Band 66	20M	QPSK	1	0	Front	21mm	Ant 0	Sensor Off	132322	1745	23.20	24.00	1.202	0.03	0.042	0.050
	LTE Band 66	20M	QPSK	1	0	Back	17mm	Ant 0	Sensor Off	132322	1745	23.20	24.00	1.202	-0.02	0.000	0.000
	LTE Band 66	20M	QPSK	1	0	Left Side	31mm	Ant 0	Sensor Off	132322	1745	23.20	24.00	1.202	0.01	0.068	0.082
	LTE Band 66	20M	QPSK	1	0	Front	10mm	Ant 6	Sensor Off	132322	1745	23.11	24.00	1.227	-0.04	0.807	0.991
	LTE Band 66_EN-DC	20M	QPSK	1	0	Front	10mm	Ant 6	Sensor On	132322	1745	20.60	21.50	1.230	-0.05	0.378	0.465
	LTE Band 66	20M	QPSK	1	0	Front	10mm	Ant 6	Sensor Off	132072	1720	23.10	24.00	1.230	0.070	0.765	0.941
	LTE Band 66	20M	QPSK	1	0	Front	10mm	Ant 6	Sensor Off	132572	1770	22.69	24.00	1.352	0.1	0.731	0.988
	LTE Band 66	20M	QPSK	50	0	Front	10mm	Ant 6	Sensor Off	132322	1745	22.00	23.00	1.259	0.03	0.634	0.798
	LTE Band 66	20M	QPSK	100	0	Front	10mm	Ant 6	Sensor Off	132322	1745	21.98	23.00	1.265	-0.02	0.710	0.898
	LTE Band 66	20M	QPSK	1	0	Back	10mm	Ant 6	Sensor Off	132322	1745	23.11	24.00	1.227	0.06	0.618	0.759
	LTE Band 66	20M	QPSK	50	0	Back	10mm	Ant 6	Sensor Off	132322	1745	22.00	23.00	1.259	0.02	0.489	0.616
	LTE Band 66	20M	QPSK	1	0	Left Side	10mm	Ant6	Sensor Off	132322	1745	23.11	24.00	1.227	0.06	0.050	0.061
	LTE Band 66	20M	QPSK	50	0	Left Side	10mm	Ant6	Sensor Off	132322	1745	22.00	23.00	1.259	-0.06	0.013	0.016
	LTE Band 66	20M	QPSK	1	0	Right Side	10mm	Ant6	Sensor Off	132322	1745	23.11	24.00	1.227	0.11	0.262	0.322
	LTE Band 66	20M	QPSK	50	0	Right Side	10mm	Ant6	Sensor Off	132322	1745	22.00	23.00	1.259	0.04	0.206	0.259
	LTE Band 66	20M	QPSK	1	0	Top Side	10mm	Ant 6	Sensor Off	132322	1745	23.11	24.00	1.227	-0.17	0.362	0.444
	LTE Band 66	20M	QPSK	50	0	Top Side	10mm	Ant 6	Sensor Off	132322	1745	22.00	23.00	1.259	-0.07	0.293	0.369
	LTE Band 66	20M	QPSK	1	0	Bottom Side	10mm	Ant6	Sensor Off	132322	1745	23.11	24.00	1.227	0.13	0.083	0.102
	LTE Band 66	20M	QPSK	50	0	Bottom Side	10mm	Ant6	Sensor Off	132322	1745	22.00	23.00	1.259	0.06	0.065	0.082
	LTE Band 66	20M	QPSK	1	0	Front	17mm	Ant6	Sensor Off	132322	1745	23.11	24.00	1.227	0.07	0.334	0.410
	LTE Band 66	20M	QPSK	1	0	Front	10mm	Ant 1	Sensor Off	132322	1745	18.83	20.00	1.309	0.07	0.016	0.021
	LTE Band 66	20M	QPSK	50	0	Front	10mm	Ant 1	Sensor Off	132322	1745	17.83	19.00	1.309	0.05	0.014	0.018
	LTE Band 66	20M	QPSK	1	0	Back	10mm	Ant 1	Sensor Off	132322	1745	18.83	20.00	1.309	-0.01	0.026	0.034



**FCC SAR Test Report**

**Report No. : FA182710**

LTE Band 66C	20M	QPSK	1	0	Back	10mm	Ant 1	Sensor Off	132322+132124	1745+1725.2	18.81	20.00	1.315	0.12	0.019	0.025
LTE Band 66	20M	QPSK	50	0	Back	10mm	Ant 1	Sensor Off	132322	1745	17.83	19.00	1.309	0.08	0.022	0.029
LTE Band 66	20M	QPSK	1	0	Left Side	10mm	Ant 1	Sensor Off	132322	1745	18.83	20.00	1.309	0.05	0.003	0.004
LTE Band 66	20M	QPSK	50	0	Left Side	10mm	Ant 1	Sensor Off	132322	1745	17.83	19.00	1.309	0.05	0.003	0.004
LTE Band 66	20M	QPSK	1	0	Right Side	10mm	Ant 1	Sensor Off	132322	1745	18.83	20.00	1.309	0.02	0.017	0.022
LTE Band 66	20M	QPSK	50	0	Right Side	10mm	Ant 1	Sensor Off	132322	1745	17.83	19.00	1.309	0.17	0.014	0.018
LTE Band 66	20M	QPSK	1	0	Top Side	10mm	Ant 1	Sensor Off	132322	1745	18.83	20.00	1.309	-0.13	0.006	0.008
LTE Band 66	20M	QPSK	50	0	Top Side	10mm	Ant 1	Sensor Off	132322	1745	17.83	19.00	1.309	0.06	0.004	0.005
LTE Band 66	20M	QPSK	1	0	Bottom Side	10mm	Ant 1	Sensor Off	132322	1745	18.83	20.00	1.309	-0.06	0.007	0.009
LTE Band 66	20M	QPSK	50	0	Bottom Side	10mm	Ant 1	Sensor Off	132322	1745	17.83	19.00	1.309	0.11	0.004	0.005
LTE Band 66	20M	QPSK	1	0	Front	10mm	Ant 2	Sensor Off	132322	1745	22.98	24.00	1.265	-0.02	0.104	0.132
LTE Band 66C	20M	QPSK	1	0	Front	10mm	Ant 2	Sensor Off	132322+132124	1745+1725.2	22.81	24.00	1.315	-0.02	0.086	0.113
LTE Band 66	20M	QPSK	50	0	Front	10mm	Ant 2	Sensor Off	132322	1745	22.04	23.00	1.247	0.17	0.087	0.109
LTE Band 66	20M	QPSK	1	0	Back	10mm	Ant 2	Sensor Off	132322	1745	22.98	24.00	1.265	-0.13	0.052	0.066
LTE Band 66	20M	QPSK	50	0	Back	10mm	Ant 2	Sensor Off	132322	1745	22.04	23.00	1.247	0.06	0.040	0.050
LTE Band 66	20M	QPSK	1	0	Left Side	10mm	Ant 2	Sensor Off	132322	1745	22.98	24.00	1.265	-0.06	0.012	0.015
LTE Band 66	20M	QPSK	50	0	Left Side	10mm	Ant 2	Sensor Off	132322	1745	22.04	23.00	1.247	-0.17	0.009	0.011
LTE Band 66	20M	QPSK	1	0	Right Side	10mm	Ant 2	Sensor Off	132322	1745	22.98	24.00	1.265	0.12	0.011	0.014
LTE Band 66	20M	QPSK	50	0	Right Side	10mm	Ant 2	Sensor Off	132322	1745	22.04	23.00	1.247	0.01	0.010	0.012
LTE Band 66	20M	QPSK	1	0	Top Side	10mm	Ant 2	Sensor Off	132322	1745	22.98	24.00	1.265	0.08	0.017	0.022
LTE Band 66	20M	QPSK	50	0	Top Side	10mm	Ant 2	Sensor Off	132322	1745	22.04	23.00	1.247	0.02	0.012	0.015
LTE Band 66	20M	QPSK	1	0	Bottom Side	10mm	Ant 2	Sensor Off	132322	1745	22.98	24.00	1.265	0.06	0.079	0.100
LTE Band 66	20M	QPSK	50	0	Bottom Side	10mm	Ant 2	Sensor Off	132322	1745	22.04	23.00	1.247	-0.16	0.066	0.082
LTE Band 66	20M	QPSK	1	0	Front	10mm	Ant 3	Sensor Off	132322	1745	21.23	22.00	1.194	-0.02	0.161	0.192
LTE Band 66C	20M	QPSK	1	0	Front	10mm	Ant 3	Sensor Off	132322+132124	1745+1725.2	21.18	22.00	1.208	0.13	0.148	0.179
LTE Band 66	20M	QPSK	50	0	Front	10mm	Ant 3	Sensor Off	132322	1745	20.31	21.00	1.172	0.04	0.125	0.147
LTE Band 66	20M	QPSK	1	0	Back	10mm	Ant 3	Sensor Off	132322	1745	21.23	22.00	1.194	-0.04	0.142	0.170
LTE Band 66	20M	QPSK	50	0	Back	10mm	Ant 3	Sensor Off	132322	1745	20.31	21.00	1.172	-0.06	0.115	0.135
LTE Band 66	20M	QPSK	1	0	Left Side	10mm	Ant 3	Sensor Off	132322	1745	21.23	22.00	1.194	-0.09	0.022	0.026
LTE Band 66	20M	QPSK	50	0	Left Side	10mm	Ant 3	Sensor Off	132322	1745	20.31	21.00	1.172	-0.04	0.017	0.020
LTE Band 66	20M	QPSK	1	0	Right Side	10mm	Ant 3	Sensor Off	132322	1745	21.23	22.00	1.194	0.07	0.024	0.029
LTE Band 66	20M	QPSK	50	0	Right Side	10mm	Ant 3	Sensor Off	132322	1745	20.31	21.00	1.172	-0.05	0.018	0.021
LTE Band 66	20M	QPSK	1	0	Top Side	10mm	Ant 3	Sensor Off	132322	1745	21.23	22.00	1.194	0.02	0.100	0.119
LTE Band 66	20M	QPSK	50	0	Top Side	10mm	Ant 3	Sensor Off	132322	1745	20.31	21.00	1.172	0.05	0.078	0.091
LTE Band 66	20M	QPSK	1	0	Bottom Side	10mm	Ant 3	Sensor Off	132322	1745	21.23	22.00	1.194	0.16	0.051	0.061
LTE Band 66	20M	QPSK	50	0	Bottom Side	10mm	Ant 3	Sensor Off	132322	1745	20.31	21.00	1.172	0.02	0.042	0.049



<TDD LTE SAR>

Plot No.	Band	BW (MHz)	Modulation	RB Size	RB offset	Test Position	Gap (mm)	Antenna	Power Reduction	Ch.	Freq. (MHz)	Average Power (dBm)	Tune-Up Limit (dBm)	Tune-up Scaling Factor	Duty Cycle %	Duty Cycle Scaling Factor	Power Drift (dB)	Measured 1g SAR (W/kg)	Reported 1g SAR (W/kg)
	LTE Band 48	20M	QPSK	1	0	Front	10mm	Ant 4	Sensor Off	55830	3609	22.37	22.50	1.030	62.9	1.006	-0.13	0.185	0.192
	LTE Band 48	20M	QPSK	50	0	Front	10mm	Ant 4	Sensor Off	55830	3609	21.47	21.50	1.007	62.9	1.006	0.19	0.169	0.171
	LTE Band 48	20M	QPSK	1	0	Back	10mm	Ant 4	Sensor Off	55830	3609	22.37	22.50	1.030	62.9	1.006	0.1	0.099	0.103
	LTE Band 48	20M	QPSK	50	0	Back	10mm	Ant 4	Sensor Off	55830	3609	21.47	21.50	1.007	62.9	1.006	0.06	0.084	0.085
	LTE Band 48	20M	QPSK	1	0	Left Side	10mm	Ant 4	Sensor Off	55830	3609	22.37	22.50	1.030	62.9	1.006	-0.02	0.076	0.079
	LTE Band 48	20M	QPSK	50	0	Left Side	10mm	Ant 4	Sensor Off	55830	3609	21.47	21.50	1.007	62.9	1.006	0.01	0.065	0.066
	LTE Band 48	20M	QPSK	1	0	Right Side	10mm	Ant 4	Sensor Off	55830	3609	22.37	22.50	1.030	62.9	1.006	0.04	0.008	0.008
	LTE Band 48	20M	QPSK	50	0	Right Side	10mm	Ant 4	Sensor Off	55830	3609	21.47	21.50	1.007	62.9	1.006	0.08	0.008	0.008
	LTE Band 48	20M	QPSK	1	0	Top Side	10mm	Ant 4	Sensor Off	55830	3609	22.37	22.50	1.030	62.9	1.006	-0.06	0.016	0.017
	LTE Band 48	20M	QPSK	50	0	Top Side	10mm	Ant 4	Sensor Off	55830	3609	21.47	21.50	1.007	62.9	1.006	-0.09	0.014	0.014
	LTE Band 48	20M	QPSK	1	0	Bottom Side	10mm	Ant 4	Sensor Off	55830	3609	22.37	22.50	1.030	62.9	1.006	-0.08	0.225	0.233
	LTE Band 48C	20M	QPSK	1	0	Bottom Side	10mm	Ant 4	Sensor Off	55830+55632	3609+3589.2	22.37	22.50	1.030	62.9	1.006	0.13	0.211	0.219
	LTE Band 48	20M	QPSK	50	0	Bottom Side	10mm	Ant 4	Sensor Off	55830	3609	21.47	21.50	1.007	62.9	1.006	0.02	0.186	0.188
	LTE Band 48	20M	QPSK	1	0	Front	10mm	Ant 2	Sensor Off	55830	3609	14.17	15.00	1.211	62.9	1.006	-0.12	0.083	0.101
	LTE Band 48	20M	QPSK	50	0	Front	10mm	Ant 2	Sensor Off	55830	3609	13.68	14.00	1.076	62.9	1.006	0.02	0.074	0.080
	LTE Band 48	20M	QPSK	1	0	Back	10mm	Ant 2	Sensor Off	55830	3609	14.17	15.00	1.211	62.9	1.006	0.07	0.065	0.079
	LTE Band 48	20M	QPSK	50	0	Back	10mm	Ant 2	Sensor Off	55830	3609	13.68	14.00	1.076	62.9	1.006	-0.05	0.060	0.065
	LTE Band 48	20M	QPSK	1	0	Left Side	10mm	Ant 2	Sensor Off	55830	3609	14.17	15.00	1.211	62.9	1.006	-0.05	0.020	0.024
	LTE Band 48	20M	QPSK	50	0	Left Side	10mm	Ant 2	Sensor Off	55830	3609	13.68	14.00	1.076	62.9	1.006	0.06	0.018	0.019
	LTE Band 48	20M	QPSK	1	0	Right Side	10mm	Ant 2	Sensor Off	55830	3609	14.17	15.00	1.211	62.9	1.006	-0.03	0.007	0.009
	LTE Band 48	20M	QPSK	50	0	Right Side	10mm	Ant 2	Sensor Off	55830	3609	13.68	14.00	1.076	62.9	1.006	-0.16	0.008	0.009
	LTE Band 48	20M	QPSK	1	0	Top Side	10mm	Ant 2	Sensor Off	55830	3609	14.17	15.00	1.211	62.9	1.006	-0.06	0.002	0.002
	LTE Band 48	20M	QPSK	50	0	Top Side	10mm	Ant 2	Sensor Off	55830	3609	13.68	14.00	1.076	62.9	1.006	-0.06	0.002	0.002
05	LTE Band 48	20M	QPSK	1	0	Bottom Side	10mm	Ant 2	Sensor Off	55830	3609	14.17	15.00	1.211	62.9	1.006	-0.02	0.363	0.442
	LTE Band 48C	20M	QPSK	1	0	Bottom Side	10mm	Ant 2	Sensor Off	55830+55632	3609+3589.2	14.13	15.00	1.222	62.9	1.006	0.11	0.342	0.420
	LTE Band 48	20M	QPSK	50	0	Bottom Side	10mm	Ant 2	Sensor Off	55830	3609	13.68	14.00	1.076	62.9	1.006	0.01	0.384	0.416
	LTE Band 48	20M	QPSK	1	0	Front	10mm	Ant 3	Sensor Off	55830	3609	21.24	22.00	1.191	62.9	1.006	-0.09	0.190	0.228
	LTE Band 48C	20M	QPSK	1	0	Front	10mm	Ant 3	Sensor Off	55830+55632	3609+3589.2	21.18	22.00	1.208	62.9	1.006	0.02	0.168	0.204
	LTE Band 48	20M	QPSK	50	0	Front	10mm	Ant 3	Sensor Off	55830	3609	20.44	21.00	1.138	62.9	1.006	0.06	0.155	0.177
	LTE Band 48	20M	QPSK	1	0	Back	10mm	Ant 3	Sensor Off	55830	3609	21.24	22.00	1.191	62.9	1.006	0.13	0.030	0.036
	LTE Band 48	20M	QPSK	50	0	Back	10mm	Ant 3	Sensor Off	55830	3609	20.44	21.00	1.138	62.9	1.006	0.19	0.024	0.027
	LTE Band 48	20M	QPSK	1	0	Left Side	10mm	Ant 3	Sensor Off	55830	3609	21.24	22.00	1.191	62.9	1.006	0.13	0.037	0.044
	LTE Band 48	20M	QPSK	50	0	Left Side	10mm	Ant 3	Sensor Off	55830	3609	20.44	21.00	1.138	62.9	1.006	-0.16	0.035	0.040
	LTE Band 48	20M	QPSK	1	0	Right Side	10mm	Ant 3	Sensor Off	55830	3609	21.24	22.00	1.191	62.9	1.006	-0.02	0.012	0.014
	LTE Band 48	20M	QPSK	50	0	Right Side	10mm	Ant 3	Sensor Off	55830	3609	20.44	21.00	1.138	62.9	1.006	0.02	0.010	0.011
	LTE Band 48	20M	QPSK	1	0	Top Side	10mm	Ant 3	Sensor Off	55830	3609	21.24	22.00	1.191	62.9	1.006	0.1	0.050	0.060
	LTE Band 48	20M	QPSK	50	0	Top Side	10mm	Ant 3	Sensor Off	55830	3609	20.44	21.00	1.138	62.9	1.006	0.06	0.047	0.054
	LTE Band 48	20M	QPSK	1	0	Bottom Side	10mm	Ant 3	Sensor Off	55830	3609	21.24	22.00	1.191	62.9	1.006	-0.02	0.017	0.020
	LTE Band 48	20M	QPSK	50	0	Bottom Side	10mm	Ant 3	Sensor Off	55830	3609	20.44	21.00	1.138	62.9	1.006	0.01	0.018	0.021
	LTE Band 48	20M	QPSK	1	0	Front	10mm	Ant 5	Sensor Off	55830	3609	18.93	20.00	1.279	62.9	1.006	-0.05	0.223	0.287
	LTE Band 48C	20M	QPSK	1	0	Front	10mm	Ant 5	Sensor Off	55830+55632	3609+3589.2	18.91	20.00	1.285	62.9	1.006	0.1	0.198	0.256
	LTE Band 48	20M	QPSK	50	0	Front	10mm	Ant 5	Sensor Off	55830	3609	18.01	19.00	1.256	62.9	1.006	0.06	0.179	0.226
	LTE Band 48	20M	QPSK	1	0	Back	10mm	Ant 5	Sensor Off	55830	3609	18.93	20.00	1.279	62.9	1.006	0.13	0.156	0.201
	LTE Band 48	20M	QPSK	50	0	Back	10mm	Ant 5	Sensor Off	55830	3609	18.01	19.00	1.256	62.9	1.006	0.01	0.136	0.172
	LTE Band 48	20M	QPSK	1	0	Left Side	10mm	Ant 5	Sensor Off	55830	3609	18.93	20.00	1.279	62.9	1.006	0.04	0.051	0.066
	LTE Band 48	20M	QPSK	50	0	Left Side	10mm	Ant 5	Sensor Off	55830	3609	18.01	19.00	1.256	62.9	1.006	-0.05	0.042	0.053
	LTE Band 48	20M	QPSK	1	0	Right Side	10mm	Ant 5	Sensor Off	55830	3609	18.93	20.00	1.279	62.9	1.006	0.06	0.161	0.207
	LTE Band 48	20M	QPSK	50	0	Right Side	10mm	Ant 5	Sensor Off	55830	3609	18.01	19.00	1.256	62.9	1.006	-0.12	0.129	0.163
	LTE Band 48	20M	QPSK	1	0	Top Side	10mm	Ant 5	Sensor Off	55830	3609	18.93	20.00	1.279	62.9	1.006	0.03	0.190	0.245
	LTE Band 48	20M	QPSK	50	0	Top Side	10mm	Ant 5	Sensor Off	55830	3609	18.01	19.00	1.256	62.9	1.006	-0.13	0.167	0.211
	LTE Band 48	20M	QPSK	1	0	Bottom Side	10mm	Ant 5	Sensor Off	55830	3609	18.93	20.00	1.279	62.9	1.006	0.14	0.029	0.037
	LTE Band 48	20M	QPSK	50	0	Bottom Side	10mm	Ant 5	Sensor Off	55830	3609	18.01	19.00	1.256	62.9	1.006	0.07	0.024	0.030



<5G NR SAR>

Plot No.	Band	BW (MHz)	Modulation	RB Size	RB offset	Mode	Test Position	Gap (mm)	Antenna	Power Reduction	Ch.	Freq. (MHz)	Average Power (dBm)	Tune-Up Limit (dBm)	Tune-up Scaling Factor	Power Drift (dB)	Measured 1g SAR (W/kg)	Reported 1g SAR (W/kg)
	FR1 N2	20M	QPSK	1	1	DFT_SCS 15KHz	Front	10mm	Ant 0	Sensor On	376000	1880	19.76	20.50	1.186	0.03	0.431	0.511
	FR1 N2	20M	QPSK	50	0	DFT_SCS 15KHz	Front	10mm	Ant 0	Sensor On	376000	1880	19.64	20.50	1.219	-0.12	0.336	0.410
	FR1 N2	20M	QPSK	1	1	DFT_SCS 15KHz	Back	10mm	Ant 0	Sensor On	376000	1880	19.76	20.50	1.186	-0.03	0.420	0.498
	FR1 N2	20M	QPSK	50	0	DFT_SCS 15KHz	Back	10mm	Ant 0	Sensor On	376000	1880	19.64	20.50	1.219	-0.02	0.332	0.405
06	FR1 N2	20M	QPSK	1	1	DFT_SCS 15KHz	Left Side	10mm	Ant 0	Sensor On	376000	1880	19.76	20.50	1.186	-0.04	0.894	1.060
	FR1 N2_NSA	20M	QPSK	1	1	DFT_SCS 15KHz	Left Side	10mm	Ant0	Sensor On	376000	1880	16.77	17.50	1.183	-0.03	0.432	0.511
	FR1 N2	20M	QPSK	1	1	DFT_SCS 15KHz	Left Side	10mm	Ant 0	Sensor On	372000	1860	19.75	20.50	1.189	-0.12	0.883	1.049
	FR1 N2	20M	QPSK	1	1	DFT_SCS 15KHz	Left Side	10mm	Ant 0	Sensor On	380000	1900	19.70	20.50	1.202	0.02	0.869	1.045
	FR1 N2	20M	QPSK	50	0	DFT_SCS 15KHz	Left Side	10mm	Ant 0	Sensor On	376000	1880	19.64	20.50	1.219	0.07	0.720	0.878
	FR1 N2	20M	QPSK	50	0	DFT_SCS 15KHz	Left Side	10mm	Ant 0	Sensor On	372000	1860	19.35	20.50	1.303	-0.16	0.680	0.886
	FR1 N2	20M	QPSK	50	0	DFT_SCS 15KHz	Left Side	10mm	Ant 0	Sensor On	380000	1900	19.36	20.50	1.300	-0.12	0.684	0.889
	FR1 N2	20M	QPSK	100	0	DFT_SCS 15KHz	Left Side	10mm	Ant 0	Sensor On	376000	1880	19.62	20.50	1.225	0.07	0.778	0.953
	FR1 N2	20M	QPSK	1	1	DFT_SCS 15KHz	Right Side	10mm	Ant 0	Sensor Off	376000	1880	24.15	25.00	1.216	0.15	0.003	0.004
	FR1 N2	20M	QPSK	50	28	DFT_SCS 15KHz	Right Side	10mm	Ant 0	Sensor Off	376000	1880	23.89	25.00	1.291	0.02	0.001	0.001
	FR1 N2	20M	QPSK	1	1	DFT_SCS 15KHz	Top Side	10mm	Ant 0	Sensor Off	376000	1880	24.15	25.00	1.216	0.19	0.062	0.075
	FR1 N2	20M	QPSK	50	28	DFT_SCS 15KHz	Top Side	10mm	Ant 0	Sensor Off	376000	1880	23.89	25.00	1.291	0.05	0.046	0.059
	FR1 N2	20M	QPSK	1	1	DFT_SCS 15KHz	Bottom Side	10mm	Ant 0	Sensor Off	376000	1880	24.15	25.00	1.216	0.08	0.041	0.050
	FR1 N2	20M	QPSK	50	28	DFT_SCS 15KHz	Bottom Side	10mm	Ant 0	Sensor Off	376000	1880	23.89	25.00	1.291	0.06	0.035	0.045
	FR1 N2	20M	QPSK	1	1	DFT_SCS 15KHz	Front	21mm	Ant 0	Sensor Off	376000	1880	24.15	25.00	1.216	0.09	0.260	0.316
	FR1 N2	20M	QPSK	1	1	DFT_SCS 15KHz	Back	17mm	Ant 0	Sensor Off	376000	1880	24.15	25.00	1.216	0.01	0.316	0.384
	FR1 N2	20M	QPSK	1	1	DFT_SCS 15KHz	Left Side	31mm	Ant 0	Sensor Off	376000	1880	24.15	25.00	1.216	0.07	0.266	0.323
	FR1 N2	20M	QPSK	1	1	DFT_SCS 15KHz	Front	10mm	Ant 6	Sensor Off	376000	1880	24.23	25.00	1.194	0.07	0.768	0.917
	FR1 N2_NSA	20M	QPSK	1	1	DFT_SCS 15KHz	Front	10mm	Ant6	Sensor On	376000	1880	22.73	23.50	1.194	0.07	0.341	0.407
	FR1 N2	20M	QPSK	1	1	DFT_SCS 15KHz	Front	10mm	Ant 6	Sensor Off	372000	1860	24.01	25.00	1.256	0.05	0.725	0.911
	FR1 N2	20M	QPSK	1	1	DFT_SCS 15KHz	Front	10mm	Ant 6	Sensor Off	380000	1900	23.89	25.00	1.291	0.01	0.700	0.904
	FR1 N2	20M	QPSK	50	28	DFT_SCS 15KHz	Front	10mm	Ant 6	Sensor Off	376000	1880	24.04	25.00	1.247	0.04	0.647	0.807
	FR1 N2	20M	QPSK	50	28	DFT_SCS 15KHz	Front	10mm	Ant 6	Sensor Off	372000	1860	23.90	25.00	1.288	0.07	0.650	0.837
	FR1 N2	20M	QPSK	50	28	DFT_SCS 15KHz	Front	10mm	Ant 6	Sensor Off	380000	1900	23.79	25.00	1.321	0.04	0.642	0.848
	FR1 N2	20M	QPSK	100	0	DFT_SCS 15KHz	Front	10mm	Ant 6	Sensor Off	376000	1880	22.98	24.00	1.265	0.07	0.721	0.912
	FR1 N2	20M	QPSK	1	1	DFT_SCS 15KHz	Back	10mm	Ant 6	Sensor Off	376000	1880	24.23	25.00	1.194	0.02	0.617	0.737
	FR1 N2	20M	QPSK	50	28	DFT_SCS 15KHz	Back	10mm	Ant 6	Sensor Off	376000	1880	24.04	25.00	1.247	-0.03	0.528	0.659
	FR1 N2	20M	QPSK	1	1	DFT_SCS 15KHz	Left Side	10mm	Ant 6	Sensor Off	376000	1880	24.23	25.00	1.194	0.15	0.081	0.097
	FR1 N2	20M	QPSK	50	28	DFT_SCS 15KHz	Left Side	10mm	Ant 6	Sensor Off	376000	1880	24.04	25.00	1.247	0.16	0.078	0.097
	FR1 N2	20M	QPSK	1	1	DFT_SCS 15KHz	Right Side	10mm	Ant 6	Sensor Off	376000	1880	24.23	25.00	1.194	-0.03	0.462	0.552
	FR1 N2	20M	QPSK	50	28	DFT_SCS 15KHz	Right Side	10mm	Ant 6	Sensor Off	376000	1880	24.04	25.00	1.247	-0.14	0.426	0.531
	FR1 N2	20M	QPSK	1	1	DFT_SCS 15KHz	Top Side	10mm	Ant 6	Sensor Off	376000	1880	24.23	25.00	1.194	0.05	0.401	0.479
	FR1 N2	20M	QPSK	50	28	DFT_SCS 15KHz	Top Side	10mm	Ant 6	Sensor Off	376000	1880	24.04	25.00	1.247	0.18	0.328	0.409
	FR1 N2	20M	QPSK	1	1	DFT_SCS 15KHz	Bottom Side	10mm	Ant 6	Sensor Off	376000	1880	24.23	25.00	1.194	0.05	0.048	0.057
	FR1 N2	20M	QPSK	50	28	DFT_SCS 15KHz	Bottom Side	10mm	Ant 6	Sensor Off	376000	1880	24.04	25.00	1.247	0.09	0.000	0.000
	FR1 N2	20M	QPSK	1	1	DFT_SCS 15KHz	Front	17mm	Ant 6	Sensor Off	376000	1880	24.23	25.00	1.194	0.03	0.203	0.242
07	FR1 N5	20M	QPSK	1	1	DFT_SCS 15KHz	Front	10mm	Ant 0	Sensor Off	167300	836.5	24.34	25.00	1.164	-0.03	0.850	0.990
	FR1 N5_NSA	20M	QPSK	1	1	DFT_SCS 15KHz	Front	10mm	Ant0	Sensor On	167300	836.5	21.35	22.00	1.161	-0.06	0.425	0.494
	FR1 N5	20M	QPSK	50	28	DFT_SCS 15KHz	Front	10mm	Ant 0	Sensor Off	167300	836.5	23.98	25.00	1.265	0.05	0.704	0.890
	FR1 N5	20M	QPSK	100	0	DFT_SCS 15KHz	Front	10mm	Ant 0	Sensor Off	167300	836.5	23.47	24.00	1.130	0.07	0.710	0.802
	FR1 N5	20M	QPSK	1	1	DFT_SCS 15KHz	Back	10mm	Ant 0	Sensor Off	167300	836.5	24.34	25.00	1.164	-0.05	0.793	0.923
	FR1 N5	20M	QPSK	50	28	DFT_SCS 15KHz	Back	10mm	Ant 0	Sensor Off	167300	836.5	23.98	25.00	1.265	0.08	0.623	0.788
	FR1 N5	20M	QPSK	100	0	DFT_SCS 15KHz	Back	10mm	Ant 0	Sensor Off	167300	836.5	23.47	24.00	1.130	0.07	0.781	0.882
	FR1 N5	20M	QPSK	1	1	DFT_SCS 15KHz	Left Side	10mm	Ant 0	Sensor Off	167300	836.5	24.34	25.00	1.164	0.05	0.100	0.116
	FR1 N5	20M	QPSK	50	28	DFT_SCS 15KHz	Left Side	10mm	Ant 0	Sensor Off	167300	836.5	23.98	25.00	1.265	0.05	0.084	0.106
	FR1 N5	20M	QPSK	1	1	DFT_SCS 15KHz	Right Side	10mm	Ant 0	Sensor Off	167300	836.5	24.34	25.00	1.164	0.02	0.056	0.065
	FR1 N5	20M	QPSK	50	28	DFT_SCS 15KHz	Right Side	10mm	Ant 0	Sensor Off	167300	836.5	23.98	25.00	1.265	0.17	0.000	0.000



**FCC SAR Test Report**

**Report No. : FA182710**

	FR1 N5	20M	QPSK	1	1	DFT_SCS 15KHz	Top Side	10mm	Ant 0	Sensor Off	167300	836.5	24.34	25.00	1.164	-0.13	0.499	0.581
	FR1 N5	20M	QPSK	50	28	DFT_SCS 15KHz	Top Side	10mm	Ant 0	Sensor Off	167300	836.5	23.98	25.00	1.265	0.02	0.399	0.505
	FR1 N5	20M	QPSK	1	1	DFT_SCS 15KHz	Bottom Side	10mm	Ant 0	Sensor Off	167300	836.5	24.34	25.00	1.164	0.03	0.448	0.522
	FR1 N5	20M	QPSK	50	28	DFT_SCS 15KHz	Bottom Side	10mm	Ant 0	Sensor Off	167300	836.5	23.98	25.00	1.265	-0.05	0.344	0.435
	FR1 N5	20M	QPSK	1	1	DFT_SCS 15KHz	Front	21mm	Ant 0	Sensor Off	167300	836.5	24.34	25.00	1.164	-0.02	0.234	0.272
	FR1 N5	20M	QPSK	1	1	DFT_SCS 15KHz	Front	10mm	Ant 1	Sensor Off	167300	836.5	23.31	25.00	1.476	0.07	0.260	0.384
	FR1 N5	20M	QPSK	50	28	DFT_SCS 15KHz	Front	10mm	Ant 1	Sensor Off	167300	836.5	23.27	25.00	1.489	0.07	0.270	0.402
	FR1 N5	20M	QPSK	1	1	DFT_SCS 15KHz	Back	10mm	Ant 1	Sensor Off	167300	836.5	23.31	25.00	1.476	0.14	0.320	0.472
	FR1 N5	20M	QPSK	50	28	DFT_SCS 15KHz	Back	10mm	Ant 1	Sensor Off	167300	836.5	23.27	25.00	1.489	0.09	0.345	0.514
	FR1 N5	20M	QPSK	1	1	DFT_SCS 15KHz	Left Side	10mm	Ant 1	Sensor Off	167300	836.5	23.31	25.00	1.476	0.05	0.000	0.000
	FR1 N5	20M	QPSK	50	28	DFT_SCS 15KHz	Left Side	10mm	Ant 1	Sensor Off	167300	836.5	23.27	25.00	1.489	-0.06	0.000	0.000
	FR1 N5	20M	QPSK	1	1	DFT_SCS 15KHz	Right Side	10mm	Ant 1	Sensor Off	167300	836.5	23.31	25.00	1.476	0.09	0.000	0.000
	FR1 N5	20M	QPSK	50	28	DFT_SCS 15KHz	Right Side	10mm	Ant 1	Sensor Off	167300	836.5	23.27	25.00	1.489	0.07	0.000	0.000
	FR1 N5	20M	QPSK	1	1	DFT_SCS 15KHz	Top Side	10mm	Ant 1	Sensor Off	167300	836.5	23.31	25.00	1.476	0.03	0.144	0.213
	FR1 N5	20M	QPSK	50	28	DFT_SCS 15KHz	Top Side	10mm	Ant 1	Sensor Off	167300	836.5	23.27	25.00	1.489	-0.09	0.141	0.210
	FR1 N5	20M	QPSK	1	1	DFT_SCS 15KHz	Bottom Side	10mm	Ant 1	Sensor Off	167300	836.5	23.31	25.00	1.476	0.16	0.111	0.164
	FR1 N5	20M	QPSK	50	28	DFT_SCS 15KHz	Bottom Side	10mm	Ant 1	Sensor Off	167300	836.5	23.27	25.00	1.489	-0.13	0.115	0.171
	FR1 N66	20M	QPSK	1	1	DFT_SCS 15KHz	Front	10mm	Ant 0	Sensor On	349000	1745	22.00	22.50	1.122	0.01	0.619	0.695
	FR1 N66	20M	QPSK	50	0	DFT_SCS 15KHz	Front	10mm	Ant 0	Sensor On	349000	1745	21.88	22.50	1.153	-0.05	0.478	0.551
	FR1 N66	20M	QPSK	1	1	DFT_SCS 15KHz	Back	10mm	Ant 0	Sensor On	349000	1745	22.00	22.50	1.122	-0.14	0.442	0.496
	FR1 N66	20M	QPSK	50	0	DFT_SCS 15KHz	Back	10mm	Ant 0	Sensor On	349000	1745	21.88	22.50	1.153	0.14	0.361	0.416
08	FR1 N66	20M	QPSK	1	1	DFT_SCS 15KHz	Left Side	10mm	Ant 0	Sensor On	349000	1745	22.00	22.50	1.122	0.04	0.911	<b>1.022</b>
	FR1 N66_NSA	20M	QPSK	1	1	DFT_SCS 15KHz	Left Side	10mm	Ant0	Sensor On	349000	1745	19.52	20.00	1.117	-0.14	0.459	0.513
	FR1 N66	20M	QPSK	1	1	DFT_SCS 15KHz	Left Side	10mm	Ant 0	Sensor On	344000	1720	21.97	22.50	1.130	0.04	0.901	1.018
	FR1 N66	20M	QPSK	1	1	DFT_SCS 15KHz	Left Side	10mm	Ant 0	Sensor On	354000	1770	21.89	22.50	1.151	0.12	0.876	1.008
	FR1 N66	20M	QPSK	50	0	DFT_SCS 15KHz	Left Side	10mm	Ant 0	Sensor On	349000	1745	21.88	22.50	1.153	0.04	0.820	0.946
	FR1 N66	20M	QPSK	50	0	DFT_SCS 15KHz	Left Side	10mm	Ant 0	Sensor On	344000	1720	21.63	22.50	1.222	0.07	0.829	1.013
	FR1 N66	20M	QPSK	50	0	DFT_SCS 15KHz	Left Side	10mm	Ant 0	Sensor On	354000	1770	21.79	22.50	1.178	-0.17	0.815	0.960
	FR1 N66	20M	QPSK	100	0	DFT_SCS 15KHz	Left Side	10mm	Ant 0	Sensor On	349000	1745	21.82	22.50	1.169	0.08	0.777	0.909
	FR1 N66	20M	QPSK	1	1	DFT_SCS 15KHz	Right Side	10mm	Ant 0	Sensor Off	349000	1745	24.62	25.00	1.091	0.02	0.034	0.037
	FR1 N66	20M	QPSK	50	28	DFT_SCS 15KHz	Right Side	10mm	Ant 0	Sensor Off	349000	1745	24.24	25.00	1.191	0.17	0.030	0.036
	FR1 N66	20M	QPSK	1	1	DFT_SCS 15KHz	Top Side	10mm	Ant 0	Sensor Off	349000	1745	24.62	25.00	1.091	0.11	0.117	0.128
	FR1 N66	20M	QPSK	50	28	DFT_SCS 15KHz	Top Side	10mm	Ant 0	Sensor Off	349000	1745	24.24	25.00	1.191	0.01	0.090	0.107
	FR1 N66	20M	QPSK	1	1	DFT_SCS 15KHz	Bottom Side	10mm	Ant 0	Sensor Off	349000	1745	24.62	25.00	1.091	-0.14	0.141	0.154
	FR1 N66	20M	QPSK	50	28	DFT_SCS 15KHz	Bottom Side	10mm	Ant 0	Sensor Off	349000	1745	24.24	25.00	1.191	-0.12	0.113	0.135
	FR1 N66	20M	QPSK	1	1	DFT_SCS 15KHz	Front	21mm	Ant 0	Sensor Off	349000	1745	24.62	25.00	1.091	0.01	0.275	0.300
	FR1 N66	20M	QPSK	1	1	DFT_SCS 15KHz	Back	17mm	Ant 0	Sensor Off	349000	1745	24.62	25.00	1.091	0.06	0.020	0.021
	FR1 N66	20M	QPSK	1	1	DFT_SCS 15KHz	Left Side	31mm	Ant 0	Sensor Off	349000	1745	24.62	25.00	1.091	0.07	0.016	0.018
	FR1 N66	20M	QPSK	1	1	DFT_SCS 15KHz	Front	10mm	Ant 6	Sensor On	349000	1745	23.22	23.50	1.067	0.06	0.714	0.762
	FR1 N66_NSA	20M	QPSK	1	1	DFT_SCS 15KHz	Front	10mm	Ant6	Sensor On	349000	1745	20.20	20.50	1.072	-0.1	0.351	0.376
	FR1 N66	20M	QPSK	50	0	DFT_SCS 15KHz	Front	10mm	Ant 6	Sensor On	349000	1745	23.06	23.50	1.107	-0.03	0.530	0.587
	FR1 N66	20M	QPSK	1	1	DFT_SCS 15KHz	Back	10mm	Ant 6	Sensor On	349000	1745	23.22	23.50	1.067	0.01	0.571	0.609
	FR1 N66	20M	QPSK	50	0	DFT_SCS 15KHz	Back	10mm	Ant 6	Sensor On	349000	1745	23.06	23.50	1.107	-0.17	0.432	0.478
	FR1 N66	20M	QPSK	1	1	DFT_SCS 15KHz	Left Side	10mm	Ant 6	Sensor Off	349000	1745	24.58	25.00	1.102	0.14	0.040	0.044
	FR1 N66	20M	QPSK	50	28	DFT_SCS 15KHz	Left Side	10mm	Ant 6	Sensor Off	349000	1745	24.52	25.00	1.117	0.06	0.033	0.037
	FR1 N66	20M	QPSK	1	1	DFT_SCS 15KHz	Right Side	10mm	Ant 6	Sensor Off	349000	1745	24.58	25.00	1.102	0.14	0.205	0.226
	FR1 N66	20M	QPSK	50	28	DFT_SCS 15KHz	Right Side	10mm	Ant 6	Sensor Off	349000	1745	24.52	25.00	1.117	-0.03	0.151	0.169
	FR1 N66	20M	QPSK	1	1	DFT_SCS 15KHz	Top Side	10mm	Ant 6	Sensor On	349000	1745	23.22	23.50	1.067	0.05	0.305	0.325
	FR1 N66	20M	QPSK	50	0	DFT_SCS 15KHz	Top Side	10mm	Ant 6	Sensor On	349000	1745	23.06	23.50	1.107	-0.08	0.215	0.238
	FR1 N66	20M	QPSK	1	1	DFT_SCS 15KHz	Bottom Side	10mm	Ant 6	Sensor Off	349000	1745	24.58	25.00	1.102	-0.01	0.067	0.074
	FR1 N66	20M	QPSK	50	28	DFT_SCS 15KHz	Bottom Side	10mm	Ant 6	Sensor Off	349000	1745	24.52	25.00	1.117	-0.17	0.042	0.047
	FR1 N66	20M	QPSK	1	1	DFT_SCS 15KHz	Front	17mm	Ant 6	Sensor Off	349000	1745	24.58	25.00	1.102	-0.03	0.288	0.317
	FR1 N66	20M	QPSK	1	1	DFT_SCS 15KHz	Back	17mm	Ant 6	Sensor Off	349000	1745	24.58	25.00	1.102	0.01	0.106	0.117
	FR1 N66	20M	QPSK	1	1	DFT_SCS 15KHz	Top Side	18mm	Ant 6	Sensor Off	349000	1745	24.58	25.00	1.102	0.08	0.227	0.250
	FR1 N77	100M	QPSK	1	1	DFT_SCS 30KHz	Front	10mm	Ant 4	Sensor Off	656000	3840	23.95	25.00	1.274	0.04	0.314	0.400
	FR1 N77	100M	QPSK	135	69	DFT_SCS 30KHz	Front	10mm	Ant 4	Sensor Off	656000	3840	23.22	24.00	1.197	-0.16	0.272	0.326



# FCC SAR Test Report

Report No. : FA182710

	FR1 N77	100M	QPSK	1	1	DFT_SCS 30KHz	Back	10mm	Ant 4	Sensor Off	656000	3840	23.95	25.00	1.274	-0.02	0.166	0.211
	FR1 N77	100M	QPSK	135	69	DFT_SCS 30KHz	Back	10mm	Ant 4	Sensor Off	656000	3840	23.22	24.00	1.197	-0.14	0.191	0.229
	FR1 N77	100M	QPSK	1	1	DFT_SCS 30KHz	Left Side	10mm	Ant 4	Sensor Off	656000	3840	23.95	25.00	1.274	-0.18	0.099	0.126
	FR1 N77	100M	QPSK	135	69	DFT_SCS 30KHz	Left Side	10mm	Ant 4	Sensor Off	656000	3840	23.22	24.00	1.197	0.02	0.090	0.108
	FR1 N77	100M	QPSK	1	1	DFT_SCS 30KHz	Right Side	10mm	Ant 4	Sensor Off	656000	3840	23.95	25.00	1.274	0.11	0.018	0.023
	FR1 N77	100M	QPSK	135	69	DFT_SCS 30KHz	Right Side	10mm	Ant 4	Sensor Off	656000	3840	23.22	24.00	1.197	0.09	0.018	0.022
	FR1 N77	100M	QPSK	1	1	DFT_SCS 30KHz	Top Side	10mm	Ant 4	Sensor Off	656000	3840	23.95	25.00	1.274	-0.1	0.031	0.039
	FR1 N77	100M	QPSK	135	69	DFT_SCS 30KHz	Top Side	10mm	Ant 4	Sensor Off	656000	3840	23.22	24.00	1.197	0.04	0.027	0.032
09	FR1 N77	100M	QPSK	1	1	DFT_SCS 30KHz	Bottom Side	10mm	Ant 4	Sensor Off	656000	3840	23.95	25.00	1.274	-0.07	0.329	0.419
	FR1 N77	100M	QPSK	135	69	DFT_SCS 30KHz	Bottom Side	10mm	Ant 4	Sensor Off	656000	3840	23.22	24.00	1.197	0.08	0.292	0.349
	FR1 N77	100M	QPSK	1	1	DFT_SCS 30KHz	Front	10mm	Ant 4	Sensor Off	633334	3500.01	23.80	25.00	1.318	0.04	0.293	0.386
	FR1 N77	100M	QPSK	135	69	DFT_SCS 30KHz	Front	10mm	Ant 4	Sensor Off	633334	3500.01	22.52	24.00	1.406	-0.16	0.241	0.339
	FR1 N77	100M	QPSK	1	1	DFT_SCS 30KHz	Back	10mm	Ant 4	Sensor Off	633334	3500.01	23.80	25.00	1.318	-0.02	0.151	0.199
	FR1 N77	100M	QPSK	135	69	DFT_SCS 30KHz	Back	10mm	Ant 4	Sensor Off	633334	3500.01	22.52	24.00	1.406	-0.14	0.160	0.225
	FR1 N77	100M	QPSK	1	1	DFT_SCS 30KHz	Left Side	10mm	Ant 4	Sensor Off	633334	3500.01	23.80	25.00	1.318	-0.18	0.081	0.107
	FR1 N77	100M	QPSK	135	69	DFT_SCS 30KHz	Left Side	10mm	Ant 4	Sensor Off	633334	3500.01	22.52	24.00	1.406	0.02	0.075	0.105
	FR1 N77	100M	QPSK	1	1	DFT_SCS 30KHz	Right Side	10mm	Ant 4	Sensor Off	633334	3500.01	23.80	25.00	1.318	0.11	0.013	0.017
	FR1 N77	100M	QPSK	135	69	DFT_SCS 30KHz	Right Side	10mm	Ant 4	Sensor Off	633334	3500.01	22.52	24.00	1.406	0.09	0.016	0.022
	FR1 N77	100M	QPSK	1	1	DFT_SCS 30KHz	Top Side	10mm	Ant 4	Sensor Off	633334	3500.01	23.80	25.00	1.318	-0.1	0.024	0.032
	FR1 N77	100M	QPSK	135	69	DFT_SCS 30KHz	Top Side	10mm	Ant 4	Sensor Off	633334	3500.01	22.52	24.00	1.406	0.04	0.022	0.031
	FR1 N77	100M	QPSK	1	1	DFT_SCS 30KHz	Bottom Side	10mm	Ant 4	Sensor Off	633334	3500.01	23.80	25.00	1.318	-0.07	0.310	0.409
	FR1 N77	100M	QPSK	135	69	DFT_SCS 30KHz	Bottom Side	10mm	Ant 4	Sensor Off	633334	3500.01	22.52	24.00	1.406	0.08	0.263	0.370
	FR1 N77	100M	QPSK	1	1	DFT_SCS 30KHz	Front	10mm	Ant 5	Sensor Off	656000	3840	19.06	20.00	1.242	-0.05	0.229	0.284
	FR1 N77	100M	QPSK	135	0	DFT_SCS 30KHz	Front	10mm	Ant 5	Sensor Off	656000	3840	18.89	20.00	1.291	-0.06	0.194	0.250
	FR1 N77	100M	QPSK	1	1	DFT_SCS 30KHz	Back	10mm	Ant 5	Sensor Off	656000	3840	19.06	20.00	1.242	0.03	0.102	0.127
	FR1 N77	100M	QPSK	135	0	DFT_SCS 30KHz	Back	10mm	Ant 5	Sensor Off	656000	3840	18.89	20.00	1.291	0.17	0.084	0.108
	FR1 N77	100M	QPSK	1	1	DFT_SCS 30KHz	Left Side	10mm	Ant 5	Sensor Off	656000	3840	19.06	20.00	1.242	0.08	0.055	0.068
	FR1 N77	100M	QPSK	135	0	DFT_SCS 30KHz	Left Side	10mm	Ant 5	Sensor Off	656000	3840	18.89	20.00	1.291	-0.14	0.045	0.058
	FR1 N77	100M	QPSK	1	1	DFT_SCS 30KHz	Right Side	10mm	Ant 5	Sensor Off	656000	3840	19.06	20.00	1.242	0.07	0.132	0.164
	FR1 N77	100M	QPSK	135	0	DFT_SCS 30KHz	Right Side	10mm	Ant 5	Sensor Off	656000	3840	18.89	20.00	1.291	-0.02	0.110	0.142
	FR1 N77	100M	QPSK	1	1	DFT_SCS 30KHz	Top Side	10mm	Ant 5	Sensor Off	656000	3840	19.06	20.00	1.242	0.03	0.224	0.278
	FR1 N77	100M	QPSK	135	0	DFT_SCS 30KHz	Top Side	10mm	Ant 5	Sensor Off	656000	3840	18.89	20.00	1.291	0.05	0.178	0.230
	FR1 N77	100M	QPSK	1	1	DFT_SCS 30KHz	Bottom Side	10mm	Ant 5	Sensor Off	656000	3840	19.06	20.00	1.242	0.03	0.062	0.077
	FR1 N77	100M	QPSK	135	0	DFT_SCS 30KHz	Bottom Side	10mm	Ant 5	Sensor Off	656000	3840	18.89	20.00	1.291	0.01	0.057	0.074
	FR1 N77	100M	QPSK	1	1	DFT_SCS 30KHz	Front	10mm	Ant 5	Sensor Off	633334	3500.01	18.93	20.00	1.279	-0.05	0.210	0.269
	FR1 N77	100M	QPSK	135	0	DFT_SCS 30KHz	Front	10mm	Ant 5	Sensor Off	633334	3500.01	18.65	20.00	1.365	-0.06	0.162	0.221
	FR1 N77	100M	QPSK	1	1	DFT_SCS 30KHz	Back	10mm	Ant 5	Sensor Off	633334	3500.01	18.93	20.00	1.279	0.03	0.093	0.119
	FR1 N77	100M	QPSK	135	0	DFT_SCS 30KHz	Back	10mm	Ant 5	Sensor Off	633334	3500.01	18.65	20.00	1.365	0.17	0.066	0.090
	FR1 N77	100M	QPSK	1	1	DFT_SCS 30KHz	Left Side	10mm	Ant 5	Sensor Off	633334	3500.01	18.93	20.00	1.279	0.08	0.038	0.049
	FR1 N77	100M	QPSK	135	0	DFT_SCS 30KHz	Left Side	10mm	Ant 5	Sensor Off	633334	3500.01	18.65	20.00	1.365	-0.14	0.041	0.056
	FR1 N77	100M	QPSK	1	1	DFT_SCS 30KHz	Right Side	10mm	Ant 5	Sensor Off	633334	3500.01	18.93	20.00	1.279	0.07	0.126	0.161
	FR1 N77	100M	QPSK	135	0	DFT_SCS 30KHz	Right Side	10mm	Ant 5	Sensor Off	633334	3500.01	18.65	20.00	1.365	-0.02	0.110	0.150
	FR1 N77	100M	QPSK	1	1	DFT_SCS 30KHz	Top Side	10mm	Ant 5	Sensor Off	633334	3500.01	18.93	20.00	1.279	0.03	0.201	0.257
	FR1 N77	100M	QPSK	135	0	DFT_SCS 30KHz	Top Side	10mm	Ant 5	Sensor Off	633334	3500.01	18.65	20.00	1.365	0.05	0.142	0.194
	FR1 N77	100M	QPSK	1	1	DFT_SCS 30KHz	Bottom Side	10mm	Ant 5	Sensor Off	633334	3500.01	18.93	20.00	1.279	0.03	0.058	0.074
	FR1 N77	100M	QPSK	135	0	DFT_SCS 30KHz	Bottom Side	10mm	Ant 5	Sensor Off	633334	3500.01	18.65	20.00	1.365	0.01	0.038	0.052



<WLAN2.4G SAR>

Plot No.	Band	Mode	Test Position	Gap (mm)	Antenna	Ch.	Freq. (MHz)	Average Power (dBm)	Tune-Up Limit (dBm)	Tune-up Scaling Factor	Duty Cycle %	Duty Cycle Scaling Factor	Power Drift (dB)	Measured 1g SAR (W/kg)	Reported 1g SAR (W/kg)
	WLAN2.4GHz	802.11b 1Mbps	Front	10mm	Ant 1	11	2462	16.11	17.00	1.227	100	1.000	0.06	0.115	0.141
	WLAN2.4GHz	802.11b 1Mbps	Back	10mm	Ant 1	11	2462	16.11	17.00	1.227	100	1.000	-0.1	0.152	0.187
	WLAN2.4GHz	802.11b 1Mbps	Left Side	10mm	Ant 1	11	2462	16.11	17.00	1.227	100	1.000	-0.12	0.162	0.199
	WLAN2.4GHz	802.11b 1Mbps	Right Side	10mm	Ant 1	11	2462	16.11	17.00	1.227	100	1.000	0.01	0.002	0.002
	WLAN2.4GHz	802.11b 1Mbps	Top Side	10mm	Ant 1	11	2462	16.11	17.00	1.227	100	1.000	-0.13	0.132	0.162
	WLAN2.4GHz	802.11b 1Mbps	Bottom Side	10mm	Ant 1	11	2462	16.11	17.00	1.227	100	1.000	-0.01	0.001	0.001
	WLAN2.4GHz	802.11b 1Mbps	Front	10mm	Ant 2	11	2462	16.46	17.00	1.132	100	1.000	-0.04	0.150	0.170
	WLAN2.4GHz	802.11b 1Mbps	Back	10mm	Ant 2	11	2462	16.46	17.00	1.132	100	1.000	-0.08	0.187	0.212
	WLAN2.4GHz	802.11b 1Mbps	Left Side	10mm	Ant 2	11	2462	16.46	17.00	1.132	100	1.000	-0.01	0.041	0.046
	WLAN2.4GHz	802.11b 1Mbps	Right Side	10mm	Ant 2	11	2462	16.46	17.00	1.132	100	1.000	0.03	0.001	0.001
	WLAN2.4GHz	802.11b 1Mbps	Top Side	10mm	Ant 2	11	2462	16.46	17.00	1.132	100	1.000	0.02	0.002	0.002
10	WLAN2.4GHz	802.11b 1Mbps	Bottom Side	10mm	Ant 2	11	2462	16.46	17.00	1.132	100	1.000	-0.03	0.278	<b>0.315</b>

<WLAN5G SAR>

Plot No.	Band	Mode	Test Position	Gap (mm)	Antenna	Ch.	Freq. (MHz)	Average Power (dBm)	Tune-Up Limit (dBm)	Tune-up Scaling Factor	Duty Cycle %	Duty Cycle Scaling Factor	Power Drift (dB)	Measured 1g SAR (W/kg)	Reported 1g SAR (W/kg)
	WLAN5.2GHz	802.11n-HT40 MCS0	Front	10mm	Ant 1	38	5190	12.68	14.00	1.355	100	1.000	-0.13	0.071	0.096
	WLAN5.2GHz	802.11n-HT40 MCS0	Back	10mm	Ant 1	38	5190	12.68	14.00	1.355	100	1.000	0.12	0.065	0.088
	WLAN5.2GHz	802.11n-HT40 MCS0	Left Side	10mm	Ant 1	38	5190	12.68	14.00	1.355	100	1.000	0.13	0.050	0.068
	WLAN5.2GHz	802.11n-HT40 MCS0	Right Side	10mm	Ant 1	38	5190	12.68	14.00	1.355	100	1.000	-0.16	0.034	0.046
	WLAN5.2GHz	802.11n-HT40 MCS0	Top Side	10mm	Ant 1	38	5190	12.68	14.00	1.355	100	1.000	0.1	0.099	0.134
	WLAN5.2GHz	802.11n-HT40 MCS0	Bottom Side	10mm	Ant 1	38	5190	12.68	14.00	1.355	100	1.000	-0.08	0.027	0.037
	WLAN5.2GHz	802.11n-HT40 MCS0	Front	10mm	Ant 2	38	5190	13.41	14.00	1.146	100	1.000	-0.04	0.070	0.080
	WLAN5.2GHz	802.11n-HT40 MCS0	Back	10mm	Ant 2	38	5190	13.41	14.00	1.146	100	1.000	-0.07	0.087	0.100
	WLAN5.2GHz	802.11n-HT40 MCS0	Left Side	10mm	Ant 2	38	5190	13.41	14.00	1.146	100	1.000	0.09	0.070	0.080
	WLAN5.2GHz	802.11n-HT40 MCS0	Right Side	10mm	Ant 2	38	5190	13.41	14.00	1.146	100	1.000	0.12	0.054	0.062
	WLAN5.2GHz	802.11n-HT40 MCS0	Top Side	10mm	Ant 2	38	5190	13.41	14.00	1.146	100	1.000	-0.16	0.001	0.001
11	WLAN5.2GHz	802.11n-HT40 MCS0	Bottom Side	10mm	Ant 2	38	5190	13.41	14.00	1.146	100	1.000	0.04	0.248	<b>0.284</b>
12	WLAN5.8GHz	802.11n-HT40 MCS0	Front	10mm	Ant 1	159	5795	12.82	14.00	1.312	100	1.000	-0.04	0.144	<b>0.189</b>
	WLAN5.8GHz	802.11n-HT40 MCS0	Back	10mm	Ant 1	159	5795	12.82	14.00	1.312	100	1.000	0.03	0.086	0.113
	WLAN5.8GHz	802.11n-HT40 MCS0	Left Side	10mm	Ant 1	159	5795	12.82	14.00	1.312	100	1.000	-0.1	0.087	0.114
	WLAN5.8GHz	802.11n-HT40 MCS0	Right Side	10mm	Ant 1	159	5795	12.82	14.00	1.312	100	1.000	-0.1	0.094	0.123
	WLAN5.8GHz	802.11n-HT40 MCS0	Top Side	10mm	Ant 1	159	5795	12.82	14.00	1.312	100	1.000	0.07	0.133	0.175
	WLAN5.8GHz	802.11n-HT40 MCS0	Bottom Side	10mm	Ant 1	159	5795	12.82	14.00	1.312	100	1.000	-0.13	0.051	0.067
	WLAN5.8GHz	802.11n-HT40 MCS0	Front	10mm	Ant 2	151	5755	12.93	14.00	1.279	100	1.000	0.02	0.046	0.059
	WLAN5.8GHz	802.11n-HT40 MCS0	Back	10mm	Ant 2	151	5755	12.93	14.00	1.279	100	1.000	0.14	0.071	0.091
	WLAN5.8GHz	802.11n-HT40 MCS0	Left Side	10mm	Ant 2	151	5755	12.93	14.00	1.279	100	1.000	0.07	0.040	0.051
	WLAN5.8GHz	802.11n-HT40 MCS0	Right Side	10mm	Ant 2	151	5755	12.93	14.00	1.279	100	1.000	0.05	0.001	0.001
	WLAN5.8GHz	802.11n-HT40 MCS0	Top Side	10mm	Ant 2	151	5755	12.93	14.00	1.279	100	1.000	0.06	0.002	0.003
	WLAN5.8GHz	802.11n-HT40 MCS0	Bottom Side	10mm	Ant 2	151	5755	12.93	14.00	1.279	100	1.000	-0.02	0.089	0.114

15.2 Repeated SAR Measurement

Plot No.	Band	BW (MHz)	Modulation	RB Size	RB offset	Mode	Test Position	Gap (mm)	Antenna	Power Reduction	Ch.	Freq. (MHz)	Average Power (dBm)	Tune-Up Limit (dBm)	Tune-up Scaling Factor	Power Drift (dB)	Measured 1g SAR (W/kg)	Ratio	Reported 1g SAR (W/kg)
	FR1 N2	20M	QPSK	1	1	DFT_SCS 15KHz	Left Side	10mm	Ant 0	Sensor On	376000	1880	19.76	20.50	1.186	-0.04	0.894	1	1.060
	FR1 N2	20M	QPSK	1	1	DFT_SCS 15KHz	Left Side	10mm	Ant 0	Sensor On	376000	1880	19.76	20.50	1.186	0.06	0.871	0.026	1.033
	FR1 N5	20M	QPSK	1	1	DFT_SCS 15KHz	Front	10mm	Ant 0	Sensor Off	167300	836.5	24.34	25.00	1.164	-0.03	0.850	1	0.990
	FR1 N5	20M	QPSK	1	1	DFT_SCS 15KHz	Front	10mm	Ant 0	Sensor Off	167300	836.5	24.34	25.00	1.164	0.03	0.826	1.029	0.962
	FR1 N66	40M	QPSK	1	1	DFT_SCS 15KHz	Left Side	10mm	Ant 0	Sensor On	349000	1745	22.00	22.50	1.122	0.04	0.911	1	1.022
	FR1 N66	40M	QPSK	1	1	DFT_SCS 15KHz	Left Side	10mm	Ant 0	Sensor On	349000	1745	22.00	22.50	1.122	0.11	0.903	1.009	1.013

General Note:

1. Per KDB 865664 D01v01r04, for each frequency band, repeated SAR measurement is required only when the measured SAR is  $\geq 0.8W/kg$ .
2. Per KDB 865664 D01v01r04, if the ratio among the repeated measurement is  $\leq 1.2$  and the measured SAR  $< 1.45W/kg$ , only one repeated measurement is required.
3. The ratio is the difference in percentage between original and repeated *measured SAR*.
4. All measurement SAR result is scaled-up to account for tune-up tolerance and is compliant.

## **16. Simultaneous Transmission Analysis**

No.	Simultaneous Transmission Configurations	Body
1.	WWAN + WLAN 2.4GHz Ant 1 + WLAN 5GHz Ant 1	Yes
2.	WWAN + WLAN 2.4GHz Ant 1 + WLAN 5GHz Ant 2	Yes
3.	WWAN + WLAN 2.4GHz Ant 2 + WLAN 5GHz Ant 1	Yes
4.	WWAN + WLAN 2.4GHz Ant 2 + WLAN 5GHz Ant 2	Yes
5.	WWAN + WLAN 2.4GHz MIMO	Yes
6.	WWAN + WLAN 5GHz MIMO	Yes

**General Note:**

1. WWAN above includes 5G NR bands.
2. For SAR testing was performed on single antenna RF power in SISO mode is larger or equal to the single antenna RF power in MIMO mode, and for RF exposure assessment of MIMO mode simultaneous transmission exclusion analysis was performed with SAR test results of each antenna in SISO mode.
3. EN-DC SAR summed the standalone 5G NR SAR and LTE standalone SAR more conservatively.
4. According to the EUT characteristic, WLAN Ant 1 and WLAN Ant 2 can transmit simultaneously.
5. According to the EUT characteristic, WLAN 5GHz and WLAN 2.4GHz can transmit simultaneously.
6. Chose the worst zoom scan SAR of WLAN correspondingly for co-located with WWAN analysis.
7. The reported SAR summation is calculated based on the same configuration and test position.
8. Per KDB 447498 D01v06, simultaneous transmission SAR is compliant if,
  - i) 1g Scalar SAR summation < 1.6W/kg.
  - ii)  $SPLSR = (SAR1 + SAR2)^{1.5} / (\text{min. separation distance, mm})$ , and the peak separation distance is determined from the square root of  $[(x1-x2)^2 + (y1-y2)^2 + (z1-z2)^2]$ , where (x1, y1, z1) and (x2, y2, z2) are the coordinates of the extrapolated peak SAR locations in the zoom scan.
  - iii) If  $SPLSR \leq 0.04$  for 1g SAR, simultaneously transmission SAR measurement is not necessary.
  - iv) Simultaneously transmission SAR measurement, and the reported multi-band 1g SAR < 1.6W/kg.

**16.1 Body Exposure Conditions**

WWAN Band	Exposure Position	1	2	3	4	5	1+2+3 Summed 1g SAR (W/kg)	1+4+5 Summed 1g SAR (W/kg)	1+2+4 Summed 1g SAR (W/kg)	1+2+5 Summed 1g SAR (W/kg)	1+3+4 Summed 1g SAR (W/kg)	1+3+5 Summed 1g SAR (W/kg)
		WWAN	2.4GHz WLAN Ant 1	2.4GHz WLAN Ant 2	5GHz WLAN Ant 1	5GHz WLAN Ant 2						
		1g SAR (W/kg)	1g SAR (W/kg)	1g SAR (W/kg)	1g SAR (W/kg)	1g SAR (W/kg)						
Except n77 Ant 5 All standalone Band	Front	0.991	0.141	0.170	0.189	0.080	1.30	1.26	1.32	1.21	1.35	1.24
	Back	0.941	0.187	0.212	0.113	0.100	1.34	1.15	1.24	1.23	1.27	1.25
	Left side	1.060	0.199	0.046	0.114	0.080	1.31	1.25	1.37	1.34	1.22	1.19
	Right side	0.552	0.002	0.001	0.123	0.062	0.56	0.74	0.68	0.62	0.68	0.62
	Top side	0.581	0.162	0.002	0.175	0.003	0.75	0.76	0.92	0.75	0.76	0.59
	Bottom side	0.522	0.001	0.315	0.067	0.284	0.84	0.87	0.59	0.81	0.90	1.12

**<5G NR>**

WWAN Band	FR1 Band	Exposure Position	1	2	3	4	6	7	1+2+3+4 Summed 1g SAR (W/kg)	1+2+6+7 Summed 1g SAR (W/kg)	1+2+3+6 Summed 1g SAR (W/kg)	1+2+3+7 Summed 1g SAR (W/kg)	1+2+4+6 Summed 1g SAR (W/kg)	1+2+4+7 Summed 1g SAR (W/kg)
			WWAN	FR1	2.4GHz WLAN Ant 1	2.4GHz WLAN Ant 2	5GHz WLAN Ant 1	5GHz WLAN Ant 2						
			1g SAR (W/kg)	1g SAR (W/kg)	1g SAR (W/kg)	1g SAR (W/kg)	1g SAR (W/kg)	1g SAR (W/kg)						
LTE Band 13Ant 0	FR1 n2Ant 6	Front	0.323	0.407	0.141	0.170	0.189	0.080	1.04	1.00	1.06	0.95	1.09	0.98
		Back	0.323	0.407	0.187	0.212	0.113	0.100	1.13	0.94	1.03	1.02	1.06	1.04
		Left side	0.323	0.407	0.199	0.046	0.114	0.080	0.98	0.92	1.04	1.01	0.89	0.86
		Right side	0.323	0.407	0.002	0.001	0.123	0.062	0.73	0.92	0.86	0.79	0.85	0.79
		Top side	0.323	0.407	0.162	0.002	0.175	0.003	0.89	0.91	1.07	0.90	0.91	0.74
		Bottom side	0.323	0.407	0.001	0.315	0.067	0.284	1.05	1.08	0.80	1.02	1.11	1.33
LTE Band 13Ant 0	FR1 n66Ant 6	Front	0.323	0.376	0.141	0.170	0.189	0.080	1.01	0.97	1.03	0.92	1.06	0.95
		Back	0.323	0.376	0.187	0.212	0.113	0.100	1.10	0.91	1.00	0.99	1.02	1.01
		Left side	0.323	0.376	0.199	0.046	0.114	0.080	0.94	0.89	1.01	0.98	0.86	0.83
		Right side	0.323	0.376	0.002	0.001	0.123	0.062	0.70	0.88	0.82	0.76	0.82	0.76
		Top side	0.323	0.376	0.162	0.002	0.175	0.003	0.86	0.88	1.04	0.86	0.88	0.70
		Bottom side	0.323	0.376	0.001	0.315	0.067	0.284	1.02	1.05	0.77	0.98	1.08	1.30
LTE Band 2Ant 6	FR1 n5Ant 0	Front	0.500	0.494	0.141	0.170	0.189	0.080	1.31	1.26	1.32	1.22	1.35	1.24
		Back	0.500	0.494	0.187	0.212	0.113	0.100	1.39	1.21	1.29	1.28	1.32	1.31
		Left side	0.500	0.494	0.199	0.046	0.114	0.080	1.24	1.19	1.31	1.27	1.15	1.12
		Right side	0.500	0.494	0.002	0.001	0.123	0.062	1.00	1.18	1.12	1.06	1.12	1.06
		Top side	0.500	0.494	0.162	0.002	0.175	0.003	1.16	1.17	1.33	1.16	1.17	1.00
		Bottom side	0.500	0.494	0.001	0.315	0.067	0.284	1.31	1.35	1.06	1.28	1.38	<b>1.59</b>
LTE Band 2Ant 0	FR1 n66Ant 6	Front	0.475	0.376	0.141	0.170	0.189	0.080	1.16	1.12	1.18	1.07	1.21	1.10
		Back	0.475	0.376	0.187	0.212	0.113	0.100	1.25	1.06	1.15	1.14	1.18	1.16
		Left side	0.475	0.376	0.199	0.046	0.114	0.080	1.10	1.05	1.16	1.13	1.01	0.98
		Right side	0.475	0.376	0.002	0.001	0.123	0.062	0.85	1.04	0.98	0.92	0.98	0.91
		Top side	0.475	0.376	0.162	0.002	0.175	0.003	1.02	1.03	1.19	1.02	1.03	0.86
		Bottom side	0.475	0.376	0.001	0.315	0.067	0.284	1.17	1.20	0.92	1.14	1.23	1.45
LTE Band 5Ant 0	FR1 n66Ant 6	Front	0.422	0.376	0.141	0.170	0.189	0.080	1.11	1.07	1.13	1.02	1.16	1.05
		Back	0.488	0.376	0.187	0.212	0.113	0.100	1.26	1.08	1.16	1.15	1.19	1.18
		Left side	0.087	0.376	0.199	0.046	0.114	0.080	0.71	0.66	0.78	0.74	0.62	0.59
		Right side	0.003	0.376	0.002	0.001	0.123	0.062	0.38	0.56	0.50	0.44	0.50	0.44
		Top side	0.197	0.376	0.162	0.002	0.175	0.003	0.74	0.75	0.91	0.74	0.75	0.58
		Bottom side	0.180	0.376	0.001	0.315	0.067	0.284	0.87	0.91	0.62	0.84	0.94	1.16
LTE Band 5Ant 0	FR1 n2Ant 6	Front	0.422	0.407	0.141	0.170	0.189	0.080	1.14	1.10	1.16	1.05	1.19	1.08
		Back	0.488	0.407	0.187	0.212	0.113	0.100	1.29	1.11	1.20	1.18	1.22	1.21
		Left side	0.087	0.407	0.199	0.046	0.114	0.080	0.74	0.69	0.81	0.77	0.65	0.62
		Right side	0.003	0.407	0.002	0.001	0.123	0.062	0.41	0.60	0.54	0.47	0.53	0.47
		Top side	0.197	0.407	0.162	0.002	0.175	0.003	0.77	0.78	0.94	0.77	0.78	0.61
		Bottom side	0.180	0.407	0.001	0.315	0.067	0.284	0.90	0.94	0.66	0.87	0.97	1.19



LTE Band 66Ant 6	FR1 n2Ant 0	Front	0.465	0.511	0.141	0.170	0.189	0.080	1.29	1.25	1.31	1.20	1.34	1.23
		Back	0.465	0.511	0.187	0.212	0.113	0.100	1.38	1.19	1.28	1.26	1.30	1.29
		Left side	0.465	0.511	0.199	0.046	0.114	0.080	1.22	1.17	1.29	1.26	1.14	1.10
		Right side	0.465	0.511	0.002	0.001	0.123	0.062	0.98	1.16	1.10	1.04	1.10	1.04
		Top side	0.465	0.511	0.162	0.002	0.175	0.003	1.14	1.15	1.31	1.14	1.15	0.98
		Bottom side	0.465	0.511	0.001	0.315	0.067	0.284	1.29	1.33	1.04	1.26	1.36	1.58
LTE Band 66Ant 0	FR1 n5Ant 0	Front	0.482	0.494	0.141	0.170	0.189	0.080	1.29	1.25	1.31	1.20	1.34	1.23
		Back	0.482	0.494	0.187	0.212	0.113	0.100	1.38	1.19	1.28	1.26	1.30	1.29
		Left side	0.482	0.494	0.199	0.046	0.114	0.080	1.22	1.17	1.29	1.26	1.14	1.10
		Right side	0.482	0.494	0.002	0.001	0.123	0.062	0.98	1.16	1.10	1.04	1.10	1.04
		Top side	0.482	0.494	0.162	0.002	0.175	0.003	1.14	1.15	1.31	1.14	1.15	0.98
		Bottom side	0.482	0.494	0.001	0.315	0.067	0.284	1.29	1.33	1.04	1.26	1.36	1.58
LTE Band 13Ant 0	FR1 n77Ant 4	Front	0.323	0.400	0.141	0.170	0.189	0.080	1.03	0.99	1.05	0.94	1.08	0.97
		Back	0.323	0.229	0.187	0.212	0.113	0.100	0.95	0.77	0.85	0.84	0.88	0.86
		Left side	0.323	0.126	0.199	0.046	0.114	0.080	0.69	0.64	0.76	0.73	0.61	0.58
		Right side	0.323	0.023	0.002	0.001	0.123	0.062	0.35	0.53	0.47	0.41	0.47	0.41
		Top side	0.323	0.039	0.162	0.002	0.175	0.003	0.53	0.54	0.70	0.53	0.54	0.37
		Bottom side	0.323	0.419	0.001	0.315	0.067	0.284	1.06	1.09	0.81	1.03	1.12	1.34
LTE Band 2Ant 0	FR1 n77Ant 4	Front	0.475	0.400	0.141	0.170	0.189	0.080	1.19	1.14	1.21	1.10	1.23	1.13
		Back	0.475	0.229	0.187	0.212	0.113	0.100	1.10	0.92	1.00	0.99	1.03	1.02
		Left side	0.475	0.126	0.199	0.046	0.114	0.080	0.85	0.80	0.91	0.88	0.76	0.73
		Right side	0.475	0.023	0.002	0.001	0.123	0.062	0.50	0.68	0.62	0.56	0.62	0.56
		Top side	0.475	0.039	0.162	0.002	0.175	0.003	0.68	0.69	0.85	0.68	0.69	0.52
		Bottom side	0.475	0.419	0.001	0.315	0.067	0.284	1.21	1.25	0.96	1.18	1.28	1.49
LTE Band 66Ant 0	FR1 n77Ant 4	Front	0.482	0.400	0.141	0.170	0.189	0.080	1.19	1.15	1.21	1.10	1.24	1.13
		Back	0.482	0.229	0.187	0.212	0.113	0.100	1.11	0.92	1.01	1.00	1.04	1.02
		Left side	0.482	0.126	0.199	0.046	0.114	0.080	0.85	0.80	0.92	0.89	0.77	0.73
		Right side	0.482	0.023	0.002	0.001	0.123	0.062	0.51	0.69	0.63	0.57	0.63	0.57
		Top side	0.482	0.039	0.162	0.002	0.175	0.003	0.69	0.70	0.86	0.69	0.70	0.53
		Bottom side	0.482	0.419	0.001	0.315	0.067	0.284	1.22	1.25	0.97	1.19	1.28	1.50
LTE Band 48Ant 4	FR1 n5Ant 0	Front	0.192	0.494	0.141	0.170	0.189	0.080	1.00	0.96	1.02	0.91	1.05	0.94
		Back	0.103	0.494	0.187	0.212	0.113	0.100	1.00	0.81	0.90	0.88	0.92	0.91
		Left side	0.079	0.494	0.199	0.046	0.114	0.080	0.82	0.77	0.89	0.85	0.73	0.70
		Right side	0.008	0.494	0.002	0.001	0.123	0.062	0.51	0.69	0.63	0.57	0.63	0.57
		Top side	0.017	0.494	0.162	0.002	0.175	0.003	0.68	0.69	0.85	0.68	0.69	0.52
		Bottom side	0.233	0.494	0.001	0.315	0.067	0.284	1.04	1.08	0.80	1.01	1.11	1.33
LTE Band 2Ant 1	FR1 n66Ant 0	Front	0.054	0.695	0.141	0.170	0.189	0.080	1.06	1.02	1.08	0.97	1.11	1.00
		Back	0.071	0.496	0.187	0.212	0.113	0.100	0.97	0.78	0.87	0.85	0.89	0.88
		Left side	0.008	1.022	0.199	0.046	0.114	0.080	1.28	1.22	1.34	1.31	1.19	1.16
		Right side	0.058	0.037	0.002	0.001	0.123	0.062	0.10	0.28	0.22	0.16	0.22	0.16
		Top side	0.016	0.128	0.162	0.002	0.175	0.003	0.31	0.32	0.48	0.31	0.32	0.15
		Bottom side	0.017	0.154	0.001	0.315	0.067	0.284	0.49	0.52	0.24	0.46	0.55	0.77
LTE Band 5Ant 0	FR1 n77Ant 4	Front	0.422	0.400	0.141	0.170	0.189	0.080	1.13	1.09	1.15	1.04	1.18	1.07
		Back	0.488	0.229	0.187	0.212	0.113	0.100	1.12	0.93	1.02	1.00	1.04	1.03
		Left side	0.087	0.126	0.199	0.046	0.114	0.080	0.46	0.41	0.53	0.49	0.37	0.34
		Right side	0.003	0.023	0.002	0.001	0.123	0.062	0.03	0.21	0.15	0.09	0.15	0.09
		Top side	0.197	0.039	0.162	0.002	0.175	0.003	0.40	0.41	0.57	0.40	0.41	0.24
		Bottom side	0.180	0.419	0.001	0.315	0.067	0.284	0.92	0.95	0.67	0.88	0.98	1.20
LTE Band 48Ant 4	FR1 n66Ant 0	Front	0.192	0.695	0.141	0.170	0.189	0.080	1.20	1.16	1.22	1.11	1.25	1.14
		Back	0.103	0.496	0.187	0.212	0.113	0.100	1.00	0.81	0.90	0.89	0.92	0.91
		Left side	0.079	1.022	0.199	0.046	0.114	0.080	1.35	1.30	1.41	1.38	1.26	1.23
		Right side	0.008	0.037	0.002	0.001	0.123	0.062	0.05	0.23	0.17	0.11	0.17	0.11
		Top side	0.017	0.128	0.162	0.002	0.175	0.003	0.31	0.32	0.48	0.31	0.32	0.15
		Bottom side	0.233	0.154	0.001	0.315	0.067	0.284	0.70	0.74	0.46	0.67	0.77	0.99



<LTE Inter Band UL CA>

WWAN Band	WWAN Band	Exposure Position	1	2	3	4	6	7	1+2+3+4 Summed 1g SAR (W/kg)	1+2+6+7 Summed 1g SAR (W/kg)	1+2+3+6 Summed 1g SAR (W/kg)	1+2+3+7 Summed 1g SAR (W/kg)	1+2+4+6 Summed 1g SAR (W/kg)	1+2+4+7 Summed 1g SAR (W/kg)
			WWAN	WWAN	2.4GHz WLAN Ant 1	2.4GHz WLAN Ant 2	5GHz WLAN Ant 1	5GHz WLAN Ant 2						
			1g SAR (W/kg)	1g SAR (W/kg)	1g SAR (W/kg)	1g SAR (W/kg)	1g SAR (W/kg)	1g SAR (W/kg)						
LTE Band 2Ant 6	LTE Band 4Ant 0	Front	0.500	0.482	0.141	0.170	0.189	0.080	1.29	1.25	1.31	1.20	1.34	1.23
		Back	0.500	0.482	0.187	0.212	0.113	0.100	1.38	1.20	1.28	1.27	1.31	1.29
		Left side	0.500	0.482	0.199	0.046	0.114	0.080	1.23	1.18	1.30	1.26	1.14	1.11
		Right side	0.500	0.482	0.002	0.001	0.123	0.062	0.99	1.17	1.11	1.05	1.11	1.05
		Top side	0.500	0.482	0.162	0.002	0.175	0.003	1.15	1.16	1.32	1.15	1.16	0.99
		Bottom side	0.500	0.482	0.001	0.315	0.067	0.284	1.30	1.33	1.05	1.27	1.36	1.58
LTE Band 2Ant 6	LTE Band 4Ant 1	Front	0.500	0.021	0.141	0.170	0.189	0.080	0.83	0.79	0.85	0.74	0.88	0.77
		Back	0.500	0.034	0.187	0.212	0.113	0.100	0.93	0.75	0.83	0.82	0.86	0.85
		Left side	0.500	0.004	0.199	0.046	0.114	0.080	0.75	0.70	0.82	0.78	0.66	0.63
		Right side	0.500	0.022	0.002	0.001	0.123	0.062	0.53	0.71	0.65	0.59	0.65	0.59
		Top side	0.500	0.008	0.162	0.002	0.175	0.003	0.67	0.69	0.85	0.67	0.69	0.51
		Bottom side	0.500	0.009	0.001	0.315	0.067	0.284	0.83	0.86	0.58	0.79	0.89	1.11
LTE Band 2Ant 6	LTE Band 4Ant 2	Front	0.500	0.132	0.141	0.170	0.189	0.080	0.94	0.90	0.96	0.85	0.99	0.88
		Back	0.500	0.066	0.187	0.212	0.113	0.100	0.97	0.78	0.87	0.85	0.89	0.88
		Left side	0.500	0.015	0.199	0.046	0.114	0.080	0.76	0.71	0.83	0.79	0.68	0.64
		Right side	0.500	0.014	0.002	0.001	0.123	0.062	0.52	0.70	0.64	0.58	0.64	0.58
		Top side	0.500	0.022	0.162	0.002	0.175	0.003	0.69	0.70	0.86	0.69	0.70	0.53
		Bottom side	0.500	0.100	0.001	0.315	0.067	0.284	0.92	0.95	0.67	0.89	0.98	1.20
LTE Band 2Ant 6	LTE Band 4Ant 3	Front	0.500	0.192	0.141	0.170	0.189	0.080	1.00	0.96	1.02	0.91	1.05	0.94
		Back	0.500	0.170	0.187	0.212	0.113	0.100	1.07	0.88	0.97	0.96	1.00	0.98
		Left side	0.500	0.026	0.199	0.046	0.114	0.080	0.77	0.72	0.84	0.81	0.69	0.65
		Right side	0.500	0.029	0.002	0.001	0.123	0.062	0.53	0.71	0.65	0.59	0.65	0.59
		Top side	0.500	0.119	0.162	0.002	0.175	0.003	0.78	0.80	0.96	0.78	0.80	0.62
		Bottom side	0.500	0.061	0.001	0.315	0.067	0.284	0.88	0.91	0.63	0.85	0.94	1.16
LTE Band 2Ant 6	LTE Band 5Ant 0	Front	0.500	0.422	0.141	0.170	0.189	0.080	1.23	1.19	1.25	1.14	1.28	1.17
		Back	0.500	0.488	0.187	0.212	0.113	0.100	1.39	1.20	1.29	1.28	1.31	1.30
		Left side	0.500	0.087	0.199	0.046	0.114	0.080	0.83	0.78	0.90	0.87	0.75	0.71
		Right side	0.500	0.003	0.002	0.001	0.123	0.062	0.51	0.69	0.63	0.57	0.63	0.57
		Top side	0.500	0.197	0.162	0.002	0.175	0.003	0.86	0.88	1.03	0.86	0.87	0.70
		Bottom side	0.500	0.180	0.001	0.315	0.067	0.284	1.00	1.03	0.75	0.97	1.06	1.28
LTE Band 2Ant 6	LTE Band 13Ant 0	Front	0.500	0.323	0.141	0.170	0.189	0.080	1.13	1.09	1.15	1.04	1.18	1.07
		Back	0.500	0.323	0.187	0.212	0.113	0.100	1.22	1.04	1.12	1.11	1.15	1.14
		Left side	0.500	0.323	0.199	0.046	0.114	0.080	1.07	1.02	1.14	1.10	0.98	0.95
		Right side	0.500	0.323	0.002	0.001	0.123	0.062	0.83	1.01	0.95	0.89	0.95	0.89
		Top side	0.500	0.323	0.162	0.002	0.175	0.003	0.99	1.00	1.16	0.99	1.00	0.83
		Bottom side	0.500	0.323	0.001	0.315	0.067	0.284	1.14	1.17	0.89	1.11	1.21	1.42
LTE Band 2Ant 6	LTE Band 66Ant 0	Front	0.500	0.482	0.141	0.170	0.189	0.080	1.29	1.25	1.31	1.20	1.34	1.23
		Back	0.500	0.482	0.187	0.212	0.113	0.100	1.38	1.20	1.28	1.27	1.31	1.29
		Left side	0.500	0.482	0.199	0.046	0.114	0.080	1.23	1.18	1.30	1.26	1.14	1.11
		Right side	0.500	0.482	0.002	0.001	0.123	0.062	0.99	1.17	1.11	1.05	1.11	1.05
		Top side	0.500	0.482	0.162	0.002	0.175	0.003	1.15	1.16	1.32	1.15	1.16	0.99
		Bottom side	0.500	0.482	0.001	0.315	0.067	0.284	1.30	1.33	1.05	1.27	1.36	1.58
LTE Band 2Ant 6	LTE Band 66Ant 1	Front	0.500	0.021	0.141	0.170	0.189	0.080	0.83	0.79	0.85	0.74	0.88	0.77
		Back	0.500	0.034	0.187	0.212	0.113	0.100	0.93	0.75	0.83	0.82	0.86	0.85
		Left side	0.500	0.004	0.199	0.046	0.114	0.080	0.75	0.70	0.82	0.78	0.66	0.63
		Right side	0.500	0.022	0.002	0.001	0.123	0.062	0.53	0.71	0.65	0.59	0.65	0.59
		Top side	0.500	0.008	0.162	0.002	0.175	0.003	0.67	0.69	0.85	0.67	0.69	0.51
		Bottom side	0.500	0.009	0.001	0.315	0.067	0.284	0.83	0.86	0.58	0.79	0.89	1.11
LTE Band	LTE Band	Front	0.500	0.132	0.141	0.170	0.189	0.080	0.94	0.90	0.96	0.85	0.99	0.88
		Back	0.500	0.066	0.187	0.212	0.113	0.100	0.97	0.78	0.87	0.85	0.89	0.88



2Ant 6	66Ant 2	Left side	0.500	0.015	0.199	0.046	0.114	0.080	0.76	0.71	0.83	0.79	0.68	0.64
		Right side	0.500	0.014	0.002	0.001	0.123	0.062	0.52	0.70	0.64	0.58	0.64	0.58
		Top side	0.500	0.022	0.162	0.002	0.175	0.003	0.69	0.70	0.86	0.69	0.70	0.53
		Bottom side	0.500	0.100	0.001	0.315	0.067	0.284	0.92	0.95	0.67	0.89	0.98	1.20
LTE Band 2Ant 6	LTE Band 66Ant 3	Front	0.500	0.192	0.141	0.170	0.189	0.080	1.00	0.96	1.02	0.91	1.05	0.94
		Back	0.500	0.170	0.187	0.212	0.113	0.100	1.07	0.88	0.97	0.96	1.00	0.98
		Left side	0.500	0.026	0.199	0.046	0.114	0.080	0.77	0.72	0.84	0.81	0.69	0.65
		Right side	0.500	0.029	0.002	0.001	0.123	0.062	0.53	0.71	0.65	0.59	0.65	0.59
LTE Band 4Ant 6	LTE Band 5Ant 0	Top side	0.500	0.119	0.162	0.002	0.175	0.003	0.78	0.80	0.96	0.78	0.80	0.62
		Bottom side	0.500	0.061	0.001	0.315	0.067	0.284	0.88	0.91	0.63	0.85	0.94	1.16
		Front	0.465	0.422	0.141	0.170	0.189	0.080	1.20	1.16	1.22	1.11	1.25	1.14
		Back	0.465	0.488	0.187	0.212	0.113	0.100	1.35	1.17	1.25	1.24	1.28	1.27
LTE Band 4Ant 6	LTE Band 13Ant 0	Left side	0.465	0.087	0.199	0.046	0.114	0.080	0.80	0.75	0.87	0.83	0.71	0.68
		Right side	0.465	0.003	0.002	0.001	0.123	0.062	0.47	0.65	0.59	0.53	0.59	0.53
		Top side	0.465	0.197	0.162	0.002	0.175	0.003	0.83	0.84	1.00	0.83	0.84	0.67
		Bottom side	0.465	0.180	0.001	0.315	0.067	0.284	0.96	1.00	0.71	0.93	1.03	1.24
LTE Band 5Ant 0	LTE Band 66Ant 6	Front	0.465	0.323	0.141	0.170	0.189	0.080	1.10	1.06	1.12	1.01	1.15	1.04
		Back	0.465	0.323	0.187	0.212	0.113	0.100	1.19	1.00	1.09	1.08	1.11	1.10
		Left side	0.465	0.323	0.199	0.046	0.114	0.080	1.03	0.98	1.10	1.07	0.95	0.91
		Right side	0.465	0.323	0.002	0.001	0.123	0.062	0.79	0.97	0.91	0.85	0.91	0.85
LTE Band 5Ant 0	LTE Band 66Ant 6	Top side	0.465	0.323	0.162	0.002	0.175	0.003	0.95	0.97	1.13	0.95	0.97	0.79
		Bottom side	0.465	0.323	0.001	0.315	0.067	0.284	1.10	1.14	0.86	1.07	1.17	1.39
		Front	0.422	0.465	0.141	0.170	0.189	0.080	1.20	1.16	1.22	1.11	1.25	1.14
		Back	0.488	0.465	0.187	0.212	0.113	0.100	1.35	1.17	1.25	1.24	1.28	1.27
LTE Band 13Ant 0	LTE Band 66Ant 6	Left side	0.087	0.465	0.199	0.046	0.114	0.080	0.80	0.75	0.87	0.83	0.71	0.68
		Right side	0.003	0.465	0.002	0.001	0.123	0.062	0.47	0.65	0.59	0.53	0.59	0.53
		Top side	0.197	0.465	0.162	0.002	0.175	0.003	0.83	0.84	1.00	0.83	0.84	0.67
		Bottom side	0.180	0.465	0.001	0.315	0.067	0.284	0.96	1.00	0.71	0.93	1.03	1.24
LTE Band 13Ant 0	LTE Band 66Ant 6	Front	0.323	0.465	0.141	0.170	0.189	0.080	1.10	1.06	1.12	1.01	1.15	1.04
		Back	0.323	0.465	0.187	0.212	0.113	0.100	1.19	1.00	1.09	1.08	1.11	1.10
		Left side	0.323	0.465	0.199	0.046	0.114	0.080	1.03	0.98	1.10	1.07	0.95	0.91
		Right side	0.323	0.465	0.002	0.001	0.123	0.062	0.79	0.97	0.91	0.85	0.91	0.85
LTE Band 13Ant 0	LTE Band 66Ant 6	Top side	0.323	0.465	0.162	0.002	0.175	0.003	0.95	0.97	1.13	0.95	0.97	0.79
		Bottom side	0.323	0.465	0.001	0.315	0.067	0.284	1.10	1.14	0.86	1.07	1.17	1.39

<UL MIMO>

FR1 Band	FR1 Band	Exposure Position	1	2	3	4	6	7	1+2+3+4 Summed 1g SAR (W/kg)	1+2+6+7 Summed 1g SAR (W/kg)	1+2+3+6 Summed 1g SAR (W/kg)	1+2+3+7 Summed 1g SAR (W/kg)	1+2+4+6 Summed 1g SAR (W/kg)	1+2+4+7 Summed 1g SAR (W/kg)
			FR1 1g SAR (W/kg)	FR1 1g SAR (W/kg)	2.4GHz WLAN Ant 1 1g SAR (W/kg)	2.4GHz WLAN Ant 2 1g SAR (W/kg)	5GHz WLAN Ant 1 1g SAR (W/kg)	5GHz WLAN Ant 2 1g SAR (W/kg)						
FR1 n77Ant 4	FR1 n77Ant 5	Front	0.400	0.284	0.141	0.170	0.189	0.080	1.00	0.95	1.01	0.91	1.04	0.93
		Back	0.229	0.127	0.187	0.212	0.113	0.100	0.76	0.57	0.66	0.64	0.68	0.67
		Left side	0.126	0.068	0.199	0.046	0.114	0.080	0.44	0.39	0.51	0.47	0.35	0.32
		Right side	0.023	0.164	0.002	0.001	0.123	0.062	0.19	0.37	0.31	0.25	0.31	0.25
		Top side	0.039	0.278	0.162	0.002	0.175	0.003	0.48	0.50	0.65	0.48	0.49	0.32
		Bottom side	0.419	0.077	0.001	0.315	0.067	0.284	0.81	0.85	0.56	0.78	0.88	1.10

Test Engineer : Nick Hu, Hank Chang, Yuankai Kong



## **17. Uncertainty Assessment**

Per KDB 865664 D01 SAR measurement 100MHz to 6GHz, when the highest measured 1-g SAR within a frequency band is < 1.5 W/kg and the measured 10-g SAR within a frequency band is < 3.75 W/kg. The expanded SAR measurement uncertainty must be  $\leq 30\%$ , for a confidence interval of  $k = 2$ . If these conditions are met, extensive SAR measurement uncertainty analysis described in IEEE Std 1528-2013 is not required in SAR reports submitted for equipment approval. For this device, the highest measured 1-g SAR is less 1.5W/kg and highest measured 10-g SAR is less 3.75W/kg. Therefore, the measurement uncertainty table is not required in this report.

## **18. References**

- [1] FCC 47 CFR Part 2 “Frequency Allocations and Radio Treaty Matters; General Rules and Regulations”
- [2] ANSI/IEEE Std. C95.1-1992, “IEEE Standard for Safety Levels with Respect to Human Exposure to Radio Frequency Electromagnetic Fields, 3 kHz to 300 GHz”, September 1992
- [3] IEEE Std. 1528-2013, “IEEE Recommended Practice for Determining the Peak Spatial-Average Specific Absorption Rate (SAR) in the Human Head from Wireless Communications Devices: Measurement Techniques”, Sep 2013
- [4] SPEAG DASY System Handbook
- [5] FCC KDB 865664 D01 v01r04, "SAR Measurement Requirements for 100 MHz to 6 GHz", Aug 2015.
- [6] FCC KDB 865664 D02 v01r02, “RF Exposure Compliance Reporting and Documentation Considerations” Oct 2015.
- [7] FCC KDB 447498 D01 v06, “Mobile and Portable Device RF Exposure Procedures and Equipment Authorization Policies”, Oct 2015
- [8] FCC KDB 248227 D01 v02r02, “SAR Guidance for IEEE 802.11 (WiFi) Transmitters”, Oct 2015.
- [9] FCC KDB 616217 D04 v01r02, “SAR Evaluation Considerations for Laptop, Notebook, Netbook and Tablet Computers”, Oct 2015
- [10] FCC KDB 941225 D05 v02r05, “SAR Evaluation Considerations for LTE Devices”, Dec 2015
- [11] FCC KDB 941225 D05A v01r02, “Rel. 10 LTE SAR Test Guidance and KDB Inquiries”, Oct 2015
- [12] FCC KDB 941225 D06 v02r01, "SAR Evaluation Procedures for Portable Devices with Wireless Router Capabilities", Oct 2015.

-----THE END-----



## **Appendix A. Plots of System Performance Check**

The plots are shown as follows.

### System Check\_Head\_750MHz

**DUT: D750V3 - SN:1087**

Communication System: UID 0, CW (0); Frequency: 750 MHz; Duty Cycle: 1:1  
Medium: HSL\_750 Medium parameters used:  $f = 750$  MHz;  $\sigma = 0.902$  S/m;  $\epsilon_r = 41.62$ ;  $\rho = 1000$  kg/m<sup>3</sup>

Ambient Temperature : 23.3 °C; Liquid Temperature : 22.8 °C

#### DASY5 Configuration:

- Probe: EX3DV4 - SN3935; ConvF(10.59, 10.59, 10.59); Calibrated: 2021.4.29
- Sensor-Surface: 1.4mm (Mechanical Surface Detection)
- Electronics: DAE4 Sn1650; Calibrated: 2021.6.9
- Phantom: SAM Twin Phantom; Type: SAM Twin; Serial: TP-1697
- Measurement SW: DASY52, Version 52.10 (4); SEMCAD X Version 14.6.14 (7483)

**Pin=50mW/Area Scan (61x61x1):** Interpolated grid: dx=1.500 mm, dy=1.500 mm  
Maximum value of SAR (interpolated) = 0.545 W/kg

**Pin=50mW/Zoom Scan (5x5x7)/Cube 0:** Measurement grid: dx=8mm, dy=8mm, dz=5mm  
Reference Value = 25.52 V/m; Power Drift = 0.03 dB  
Peak SAR (extrapolated) = 0.630 W/kg  
**SAR(1 g) = 0.402 W/kg; SAR(10 g) = 0.261 W/kg**  
Maximum value of SAR (measured) = 0.549 W/kg

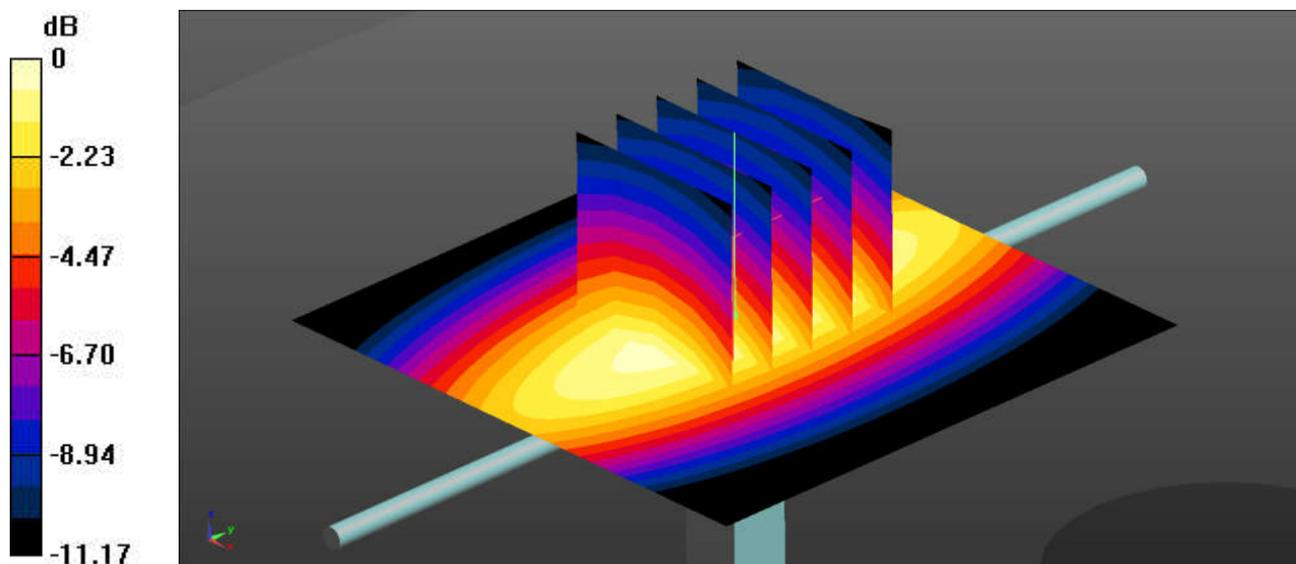

0 dB = 0.549 W/kg = -2.60 dBW/kg

### System Check\_Head\_835MHz

**DUT: D835V2 - SN:4d258**

Communication System: UID 0, CW (0); Frequency: 835 MHz; Duty Cycle: 1:1

Medium: HSL\_835 Medium parameters used:  $f = 835 \text{ MHz}$ ;  $\sigma = 0.93 \text{ S/m}$ ;  $\epsilon_r = 41.374$ ;  $\rho = 1000 \text{ kg/m}^3$

Ambient Temperature : 23.1 °C; Liquid Temperature : 22.7 °C

DASY5 Configuration:

- Probe: EX3DV4 - SN3935; ConvF(10.27, 10.27, 10.27); Calibrated: 2021.4.29
- Sensor-Surface: 1.4mm (Mechanical Surface Detection)
- Electronics: DAE4 Sn1650; Calibrated: 2021.6.9
- Phantom: SAM Twin Phantom; Type: SAM Twin; Serial: TP-1697
- Measurement SW: DASY52, Version 52.10 (4); SEMCAD X Version 14.6.14 (7483)

**Pin=50mW/Area Scan (61x61x1):** Interpolated grid:  $dx=1.500 \text{ mm}$ ,  $dy=1.500 \text{ mm}$   
Maximum value of SAR (interpolated) = 0.650 W/kg

**Pin=50mW/Zoom Scan (5x5x7)/Cube 0:** Measurement grid:  $dx=8\text{mm}$ ,  $dy=8\text{mm}$ ,  $dz=5\text{mm}$   
Reference Value = 27.51 V/m; Power Drift = 0.06 dB  
Peak SAR (extrapolated) = 0.750 W/kg  
**SAR(1 g) = 0.481 W/kg; SAR(10 g) = 0.310 W/kg**  
Maximum value of SAR (measured) = 0.657 W/kg

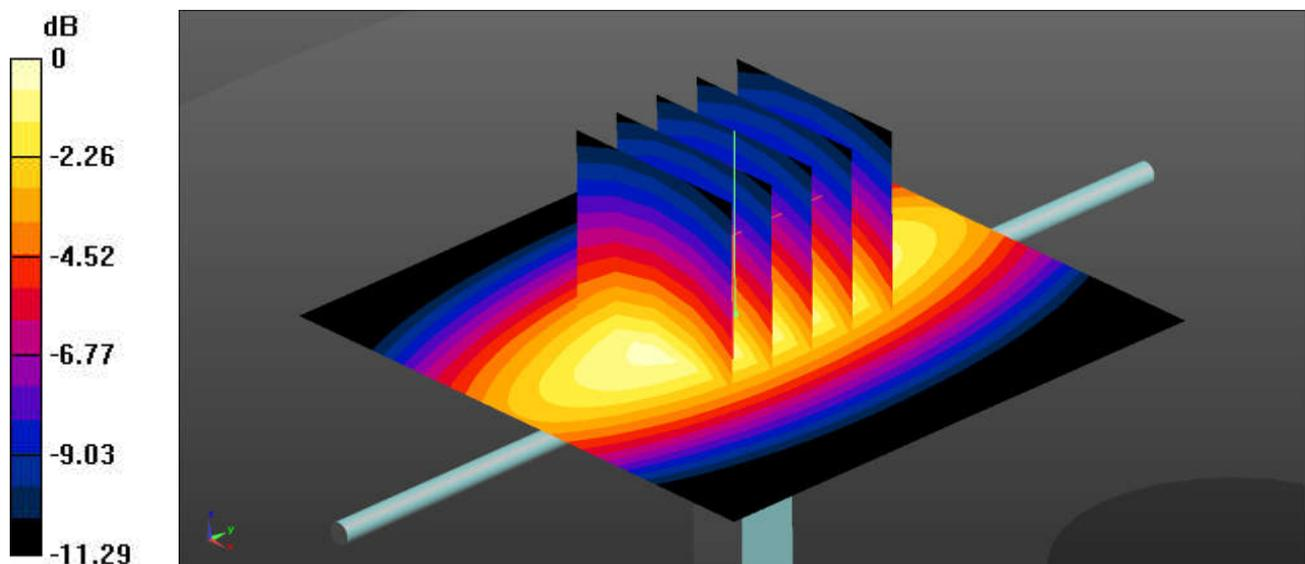

0 dB = 0.657 W/kg = -1.82 dBW/kg

### System Check\_Head\_1750MHz

**DUT: D1750V2 - SN:1090**

Communication System: UID 0, CW (0); Frequency: 1750 MHz; Duty Cycle: 1:1  
Medium: HSL\_1750 Medium parameters used:  $f = 1750$  MHz;  $\sigma = 1.351$  S/m;  $\epsilon_r = 40.014$ ;  $\rho = 1000$  kg/m<sup>3</sup>

Ambient Temperature : 23.4 °C; Liquid Temperature : 22.7 °C

#### DASY5 Configuration:

- Probe: EX3DV4 - SN3935; ConvF(8.9, 8.9, 8.9); Calibrated: 2021.4.29
- Sensor-Surface: 1.4mm (Mechanical Surface Detection)
- Electronics: DAE4 Sn1650; Calibrated: 2021.6.9
- Phantom: SAM Twin Phantom; Type: SAM Twin; Serial: TP-1697
- Measurement SW: DASY52, Version 52.10 (4); SEMCAD X Version 14.6.14 (7483)

**Pin=50mW/Area Scan (61x61x1):** Interpolated grid: dx=1.500 mm, dy=1.500 mm  
Maximum value of SAR (interpolated) = 2.90 W/kg

**Pin=50mW/Zoom Scan (5x5x7)/Cube 0:** Measurement grid: dx=8mm, dy=8mm, dz=5mm  
Reference Value = 46.67 V/m; Power Drift = 0.02 dB  
Peak SAR (extrapolated) = 3.49 W/kg  
**SAR(1 g) = 1.84 W/kg; SAR(10 g) = 0.967 W/kg**  
Maximum value of SAR (measured) = 2.87 W/kg

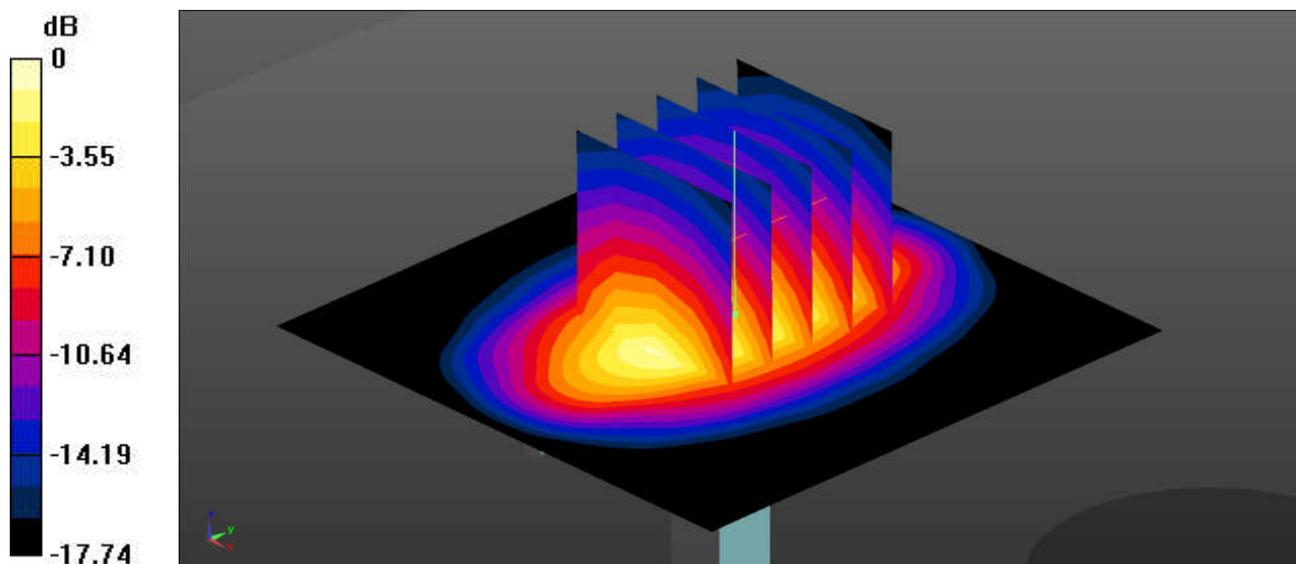

0 dB = 2.87 W/kg = 4.58 dBW/kg

### System Check\_Head\_1900MHz

**DUT: D1900V2 - SN:5d170**

Communication System: UID 0, CW (0); Frequency: 1900 MHz; Duty Cycle: 1:1  
Medium: HSL\_1900 Medium parameters used:  $f = 1900$  MHz;  $\sigma = 1.432$  S/m;  $\epsilon_r = 39.78$ ;  $\rho = 1000$  kg/m<sup>3</sup>

Ambient Temperature : 23.3 °C; Liquid Temperature : 22.9 °C

#### DASY5 Configuration:

- Probe: EX3DV4 - SN3935; ConvF(8.61, 8.61, 8.61); Calibrated: 2021.4.29
- Sensor-Surface: 1.4mm (Mechanical Surface Detection)
- Electronics: DAE4 Sn1650; Calibrated: 2021.6.9
- Phantom: SAM Twin Phantom; Type: SAM Twin; Serial: TP-1697
- Measurement SW: DASY52, Version 52.10 (4); SEMCAD X Version 14.6.14 (7483)

**Pin=50mW/Area Scan (61x61x1):** Interpolated grid: dx=1.500 mm, dy=1.500 mm  
Maximum value of SAR (interpolated) = 3.14 W/kg

**Pin=50mW/Zoom Scan (5x5x7)/Cube 0:** Measurement grid: dx=8mm, dy=8mm, dz=5mm  
Reference Value = 45.98 V/m; Power Drift = 0.16 dB  
Peak SAR (extrapolated) = 3.89 W/kg  
**SAR(1 g) = 2.01 W/kg; SAR(10 g) = 1.03 W/kg**  
Maximum value of SAR (measured) = 3.18 W/kg

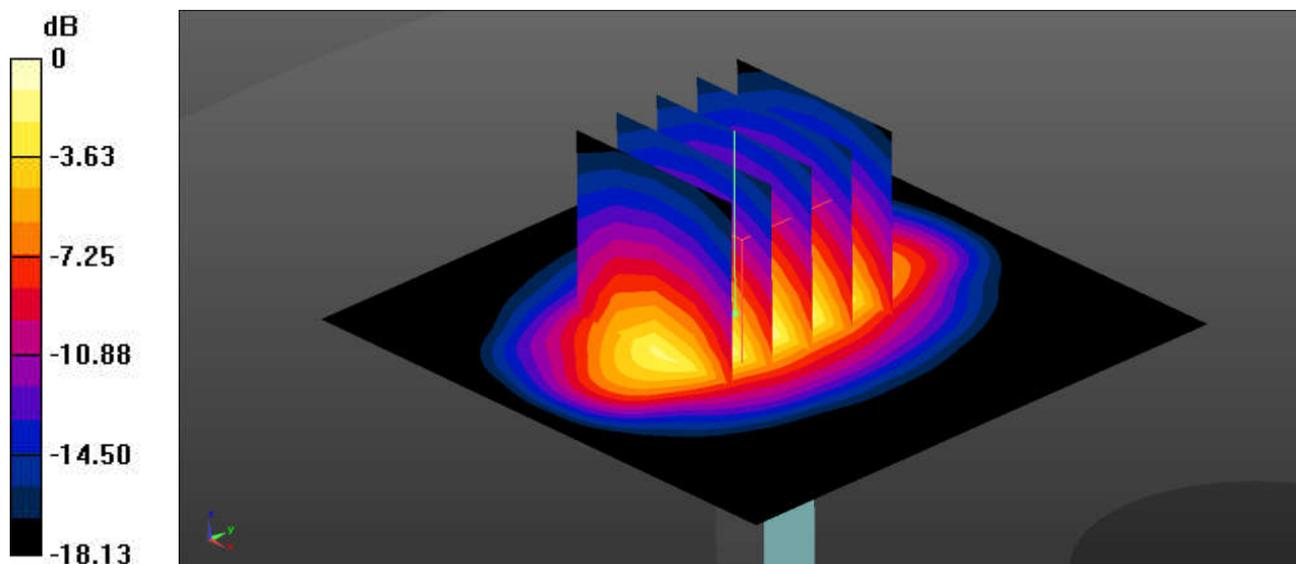

0 dB = 3.18 W/kg = 5.02 dBW/kg

### System Check\_Head\_2450MHz

**DUT: D2450V2 - SN:908**

Communication System: UID 0, CW (0); Frequency: 2450 MHz; Duty Cycle: 1:1  
Medium: HSL\_2450 Medium parameters used:  $f = 2450$  MHz;  $\sigma = 1.802$  S/m;  $\epsilon_r = 40.581$ ;  $\rho = 1000$  kg/m<sup>3</sup>

Ambient Temperature : 23.2 °C; Liquid Temperature : 22.9 °C

#### DASY5 Configuration:

- Probe: EX3DV4 - SN3935; ConvF(7.86, 7.86, 7.86); Calibrated: 2021.4.29
- Sensor-Surface: 1.4mm (Mechanical Surface Detection)
- Electronics: DAE4 Sn1650; Calibrated: 2021.6.9
- Phantom: SAM Twin Phantom; Type: SAM Twin; Serial: TP-1697
- Measurement SW: DASY52, Version 52.10 (4); SEMCAD X Version 14.6.14 (7483)

**Pin=50mW/Area Scan (71x71x1):** Interpolated grid: dx=1.200 mm, dy=1.200 mm  
Maximum value of SAR (interpolated) = 4.44 W/kg

**Pin=50mW/Zoom Scan (7x7x7)/Cube 0:** Measurement grid: dx=5mm, dy=5mm, dz=5mm  
Reference Value = 47.74 V/m; Power Drift = 0.19 dB  
Peak SAR (extrapolated) = 5.53 W/kg  
**SAR(1 g) = 2.58 W/kg; SAR(10 g) = 1.19 W/kg**  
Maximum value of SAR (measured) = 4.41 W/kg

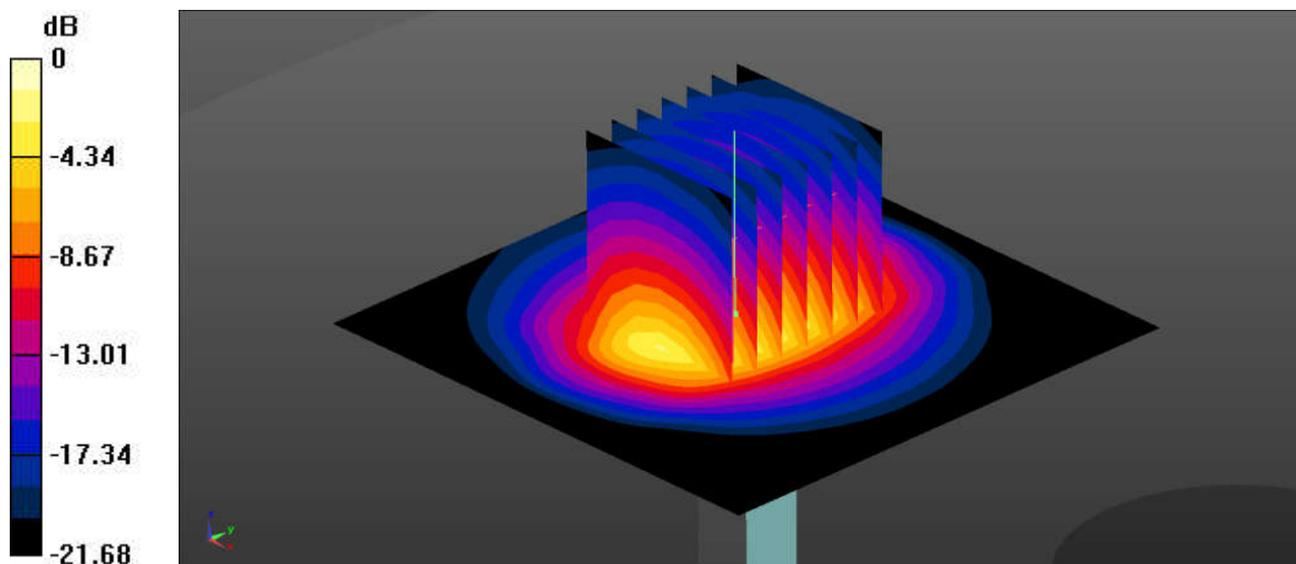

0 dB = 4.41 W/kg = 6.44 dBW/kg

### System Check\_Head\_3500MHz

**DUT: D3500V2 - SN:1037**

Communication System: UID 0, CW (0); Frequency: 3500 MHz; Duty Cycle: 1:1  
Medium: HSL\_3500 Medium parameters used:  $f = 3500$  MHz;  $\sigma = 2.833$  S/m;  $\epsilon_r = 39.056$ ;  $\rho = 1000$  kg/m<sup>3</sup>

Ambient Temperature : 23.1 °C; Liquid Temperature : 22.6 °C

#### DASY5 Configuration:

- Probe: EX3DV4 - SN3935; ConvF(7.16, 7.16, 7.16); Calibrated: 2021.4.29
- Sensor-Surface: 1.4mm (Mechanical Surface Detection)
- Electronics: DAE4 Sn1650; Calibrated: 2021.6.9
- Phantom: SAM Twin Phantom; Type: SAM Twin; Serial: TP-1697
- Measurement SW: DASY52, Version 52.10 (4); SEMCAD X Version 14.6.14 (7483)

**Pin=50mW/Area Scan (91x91x1):** Interpolated grid: dx=1.000 mm, dy=1.000 mm  
Maximum value of SAR (interpolated) = 6.51 W/kg

**Pin=50mW/Zoom Scan (7x7x7)/Cube 0:** Measurement grid: dx=4mm, dy=4mm, dz=1.4mm  
Reference Value = 36.45 V/m; Power Drift = -0.12 dB  
Peak SAR (extrapolated) = 8.91 W/kg  
**SAR(1 g) = 3.31 W/kg; SAR(10 g) = 1.26 W/kg**  
Maximum value of SAR (measured) = 6.43 W/kg

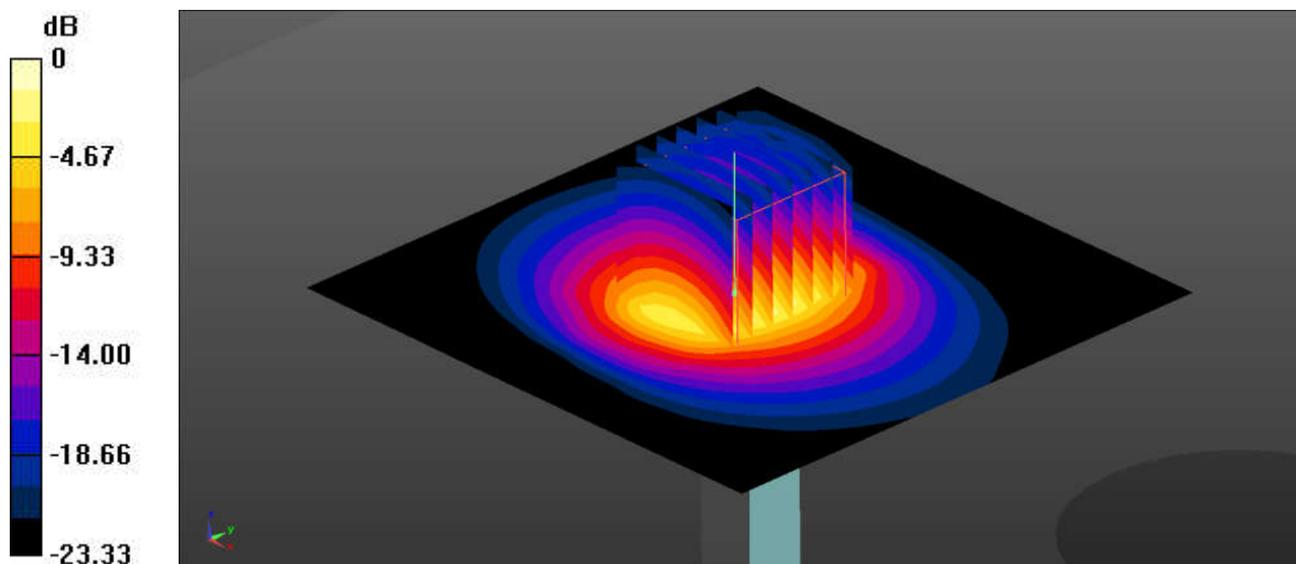

0 dB = 6.43 W/kg = 8.08 dBW/kg

### System Check\_Head\_3700MHz

**DUT: D3700V2 - SN:1008**

Communication System: UID 0, CW (0); Frequency: 3700 MHz; Duty Cycle: 1:1  
Medium: HSL\_3700 Medium parameters used:  $f = 3700$  MHz;  $\sigma = 3.024$  S/m;  $\epsilon_r = 38.72$ ;  $\rho = 1000$  kg/m<sup>3</sup>

Ambient Temperature : 23.3 °C; Liquid Temperature : 22.7 °C

#### DASY5 Configuration:

- Probe: EX3DV4 - SN3935; ConvF(7.03, 7.03, 7.03); Calibrated: 2021.4.29
- Sensor-Surface: 1.4mm (Mechanical Surface Detection)
- Electronics: DAE4 Sn1650; Calibrated: 2021.6.9
- Phantom: SAM Twin Phantom; Type: SAM Twin; Serial: TP-1697
- Measurement SW: DASY52, Version 52.10 (4); SEMCAD X Version 14.6.14 (7483)

**Pin=50mW/Area Scan (91x91x1):** Interpolated grid: dx=1.000 mm, dy=1.000 mm  
Maximum value of SAR (interpolated) = 6.78 W/kg

**Pin=50mW/Zoom Scan (9x9x7)/Cube 0:** Measurement grid: dx=4mm, dy=4mm, dz=1.4mm  
Reference Value = 49.59 V/m; Power Drift = -0.18 dB  
Peak SAR (extrapolated) = 9.28 W/kg  
**SAR(1 g) = 3.45 W/kg; SAR(10 g) = 1.29 W/kg**  
Maximum value of SAR (measured) = 6.76 W/kg

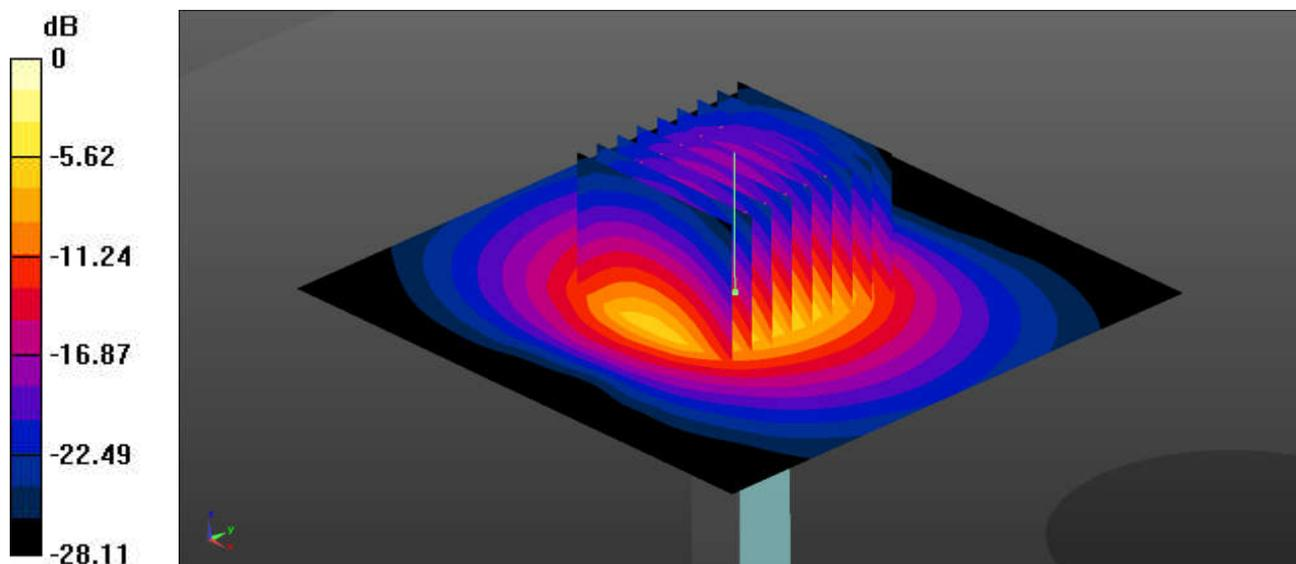

0 dB = 6.76 W/kg = 8.30 dBW/kg

### System Check\_Head\_3900MHz

**DUT: D3900V2 - SN:1048**

Communication System: UID 0, CW (0); Frequency: 3900 MHz; Duty Cycle: 1:1  
Medium: HSL\_3900 Medium parameters used:  $f = 3900$  MHz;  $\sigma = 3.227$  S/m;  $\epsilon_r = 38.419$ ;  $\rho = 1000$  kg/m<sup>3</sup>

Ambient Temperature : 23.3 °C; Liquid Temperature : 22.8 °C

#### DASY5 Configuration:

- Probe: EX3DV4 - SN3935; ConvF(6.99, 6.99, 6.99); Calibrated: 2021.4.29
- Sensor-Surface: 1.4mm (Mechanical Surface Detection)
- Electronics: DAE4 Sn1650; Calibrated: 2021.6.9
- Phantom: SAM Twin Phantom; Type: SAM Twin; Serial: TP-1697
- Measurement SW: DASY52, Version 52.10 (4); SEMCAD X Version 14.6.14 (7483)

**Pin=50mW/Area Scan (91x91x1):** Interpolated grid: dx=1.000 mm, dy=1.000 mm  
Maximum value of SAR (interpolated) = 6.66 W/kg

**Pin=50mW/Zoom Scan (7x7x7)/Cube 0:** Measurement grid: dx=4mm, dy=4mm, dz=1.4mm  
Reference Value = 46.21 V/m; Power Drift = 0.05 dB  
Peak SAR (extrapolated) = 9.57 W/kg  
**SAR(1 g) = 3.34 W/kg; SAR(10 g) = 1.18 W/kg**  
Maximum value of SAR (measured) = 6.86 W/kg

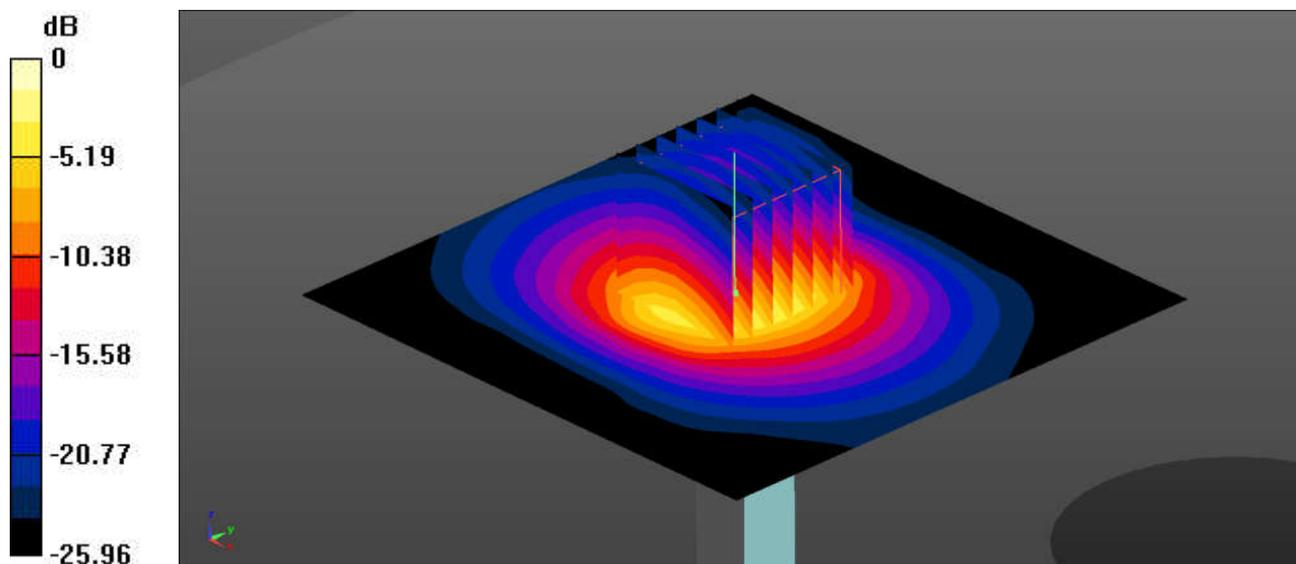

0 dB = 6.86 W/kg = 8.36 dBW/kg

### System Check\_Head\_5250MHz

#### DUT: D5GHzV2 - SN:1113

Communication System: UID 0, CW (0); Frequency: 5250 MHz; Duty Cycle: 1:1  
Medium: HSL\_5000 Medium parameters used:  $f = 5250$  MHz;  $\sigma = 4.597$  S/m;  $\epsilon_r = 35.936$ ;  $\rho = 1000$  kg/m<sup>3</sup>

Ambient Temperature : 23.2 °C; Liquid Temperature : 22.7 °C

#### DASY5 Configuration:

- Probe: EX3DV4 - SN3935; ConvF(5.04, 5.04, 5.04); Calibrated: 2021.4.29
- Sensor-Surface: 1.4mm (Mechanical Surface Detection)
- Electronics: DAE4 Sn1650; Calibrated: 2021.6.9
- Phantom: SAM Twin Phantom; Type: SAM Twin; Serial: TP-1697
- Measurement SW: DASY52, Version 52.10 (4); SEMCAD X Version 14.6.14 (7483)

**Pin=50mW/Area Scan (91x91x1):** Interpolated grid: dx=1.000 mm, dy=1.000 mm  
Maximum value of SAR (interpolated) = 9.76 W/kg

**Pin=50mW/Zoom Scan (7x7x7)/Cube 0:** Measurement grid: dx=4mm, dy=4mm, dz=1.4mm  
Reference Value = 52.66 V/m; Power Drift = -0.04 dB  
Peak SAR (extrapolated) = 17.0 W/kg  
**SAR(1 g) = 4.26 W/kg; SAR(10 g) = 1.23 W/kg**  
Maximum value of SAR (measured) = 10.7 W/kg

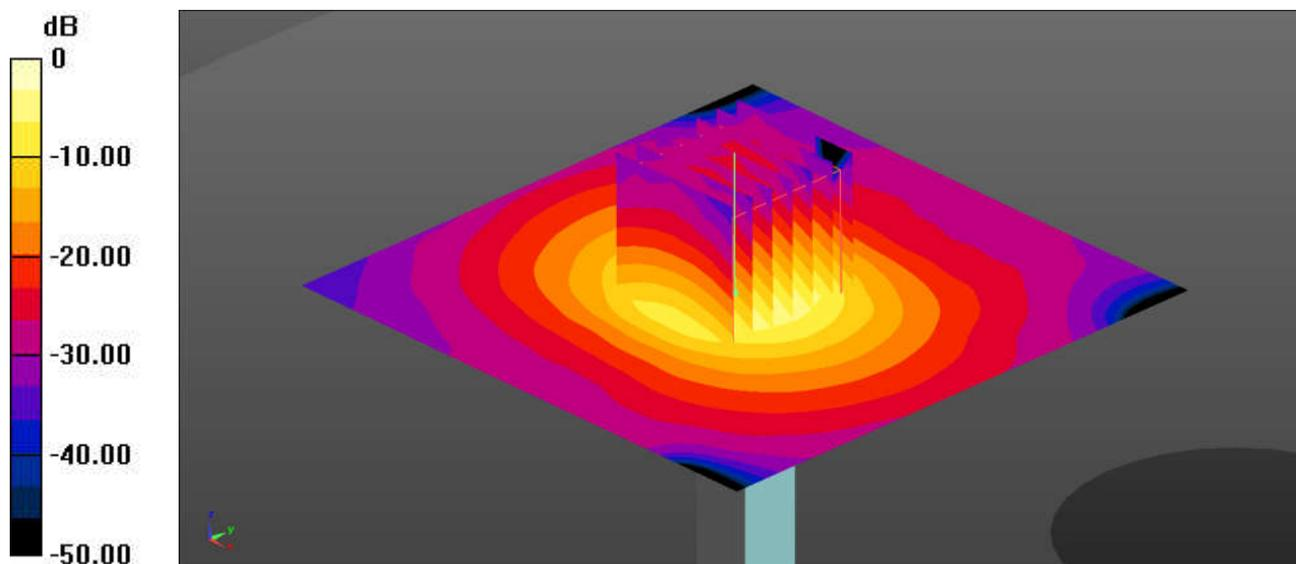

0 dB = 10.7 W/kg = 10.29 dBW/kg

### System Check\_Head\_5750MHz

#### DUT: D5GHzV2 - SN:1113

Communication System: UID 0, CW (0); Frequency: 5750 MHz; Duty Cycle: 1:1  
Medium: HSL\_5000 Medium parameters used:  $f = 5750$  MHz;  $\sigma = 5.16$  S/m;  $\epsilon_r = 35.206$ ;  $\rho = 1000$  kg/m<sup>3</sup>

Ambient Temperature : 23.4 °C; Liquid Temperature : 22.6 °C

#### DASY5 Configuration:

- Probe: EX3DV4 - SN3935; ConvF(4.71, 4.71, 4.71); Calibrated: 2021.4.29
- Sensor-Surface: 1.4mm (Mechanical Surface Detection)
- Electronics: DAE4 Sn1650; Calibrated: 2021.6.9
- Phantom: SAM Twin Phantom; Type: SAM Twin; Serial: TP-1697
- Measurement SW: DASY52, Version 52.10 (4); SEMCAD X Version 14.6.14 (7483)

**Pin=50mW/Area Scan (91x91x1):** Interpolated grid: dx=1.000 mm, dy=1.000 mm  
Maximum value of SAR (interpolated) = 9.74 W/kg

**Pin=50mW/Zoom Scan (8x8x7)/Cube 0:** Measurement grid: dx=4mm, dy=4mm, dz=1.4mm  
Reference Value = 49.52 V/m; Power Drift = -0.07 dB  
Peak SAR (extrapolated) = 18.1 W/kg  
**SAR(1 g) = 4.11 W/kg; SAR(10 g) = 1.18 W/kg**  
Maximum value of SAR (measured) = 10.7 W/kg

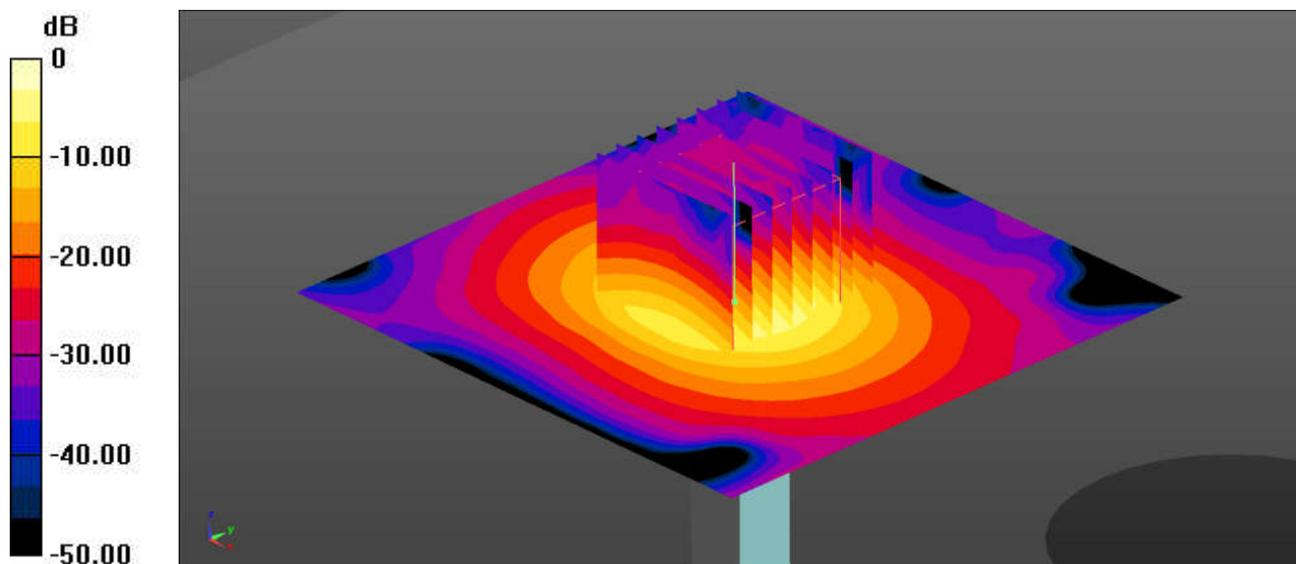

0 dB = 10.7 W/kg = 10.29 dBW/kg



**Appendix B. Plots of High SAR Measurement**

The plots are shown as follows.

### 01\_LTE Band 2\_20M\_QPSK\_1RB\_0Offset\_Left Side\_10mm\_Ch18900

Communication System: UID 0, LTE-FDD (0); Frequency: 1880 MHz; Duty Cycle: 1:1  
Medium: HSL\_1900 Medium parameters used:  $f = 1880$  MHz;  $\sigma = 1.42$  S/m;  $\epsilon_r = 39.811$ ;  $\rho = 1000$  kg/m<sup>3</sup>

Ambient Temperature : 23.3 °C; Liquid Temperature : 22.9 °C

#### DASY5 Configuration:

- Probe: EX3DV4 - SN3935; ConvF(8.61, 8.61, 8.61); Calibrated: 2021.4.29
- Sensor-Surface: 1.4mm (Mechanical Surface Detection)
- Electronics: DAE4 Sn1650; Calibrated: 2021.6.9
- Phantom: SAM Twin Phantom; Type: SAM Twin; Serial: TP-1697
- Measurement SW: DASY52, Version 52.10 (4); SEMCAD X Version 14.6.14 (7483)

**Area Scan (41x81x1):** Interpolated grid: dx=1.500 mm, dy=1.500 mm

Maximum value of SAR (interpolated) = 1.11 W/kg

**Zoom Scan (5x5x7)/Cube 0:** Measurement grid: dx=8mm, dy=8mm, dz=5mm

Reference Value = 21.46 V/m; Power Drift = 0.05 dB

Peak SAR (extrapolated) = 1.81 W/kg

**SAR(1 g) = 0.788 W/kg; SAR(10 g) = 0.342 W/kg**

Maximum value of SAR (measured) = 1.31 W/kg

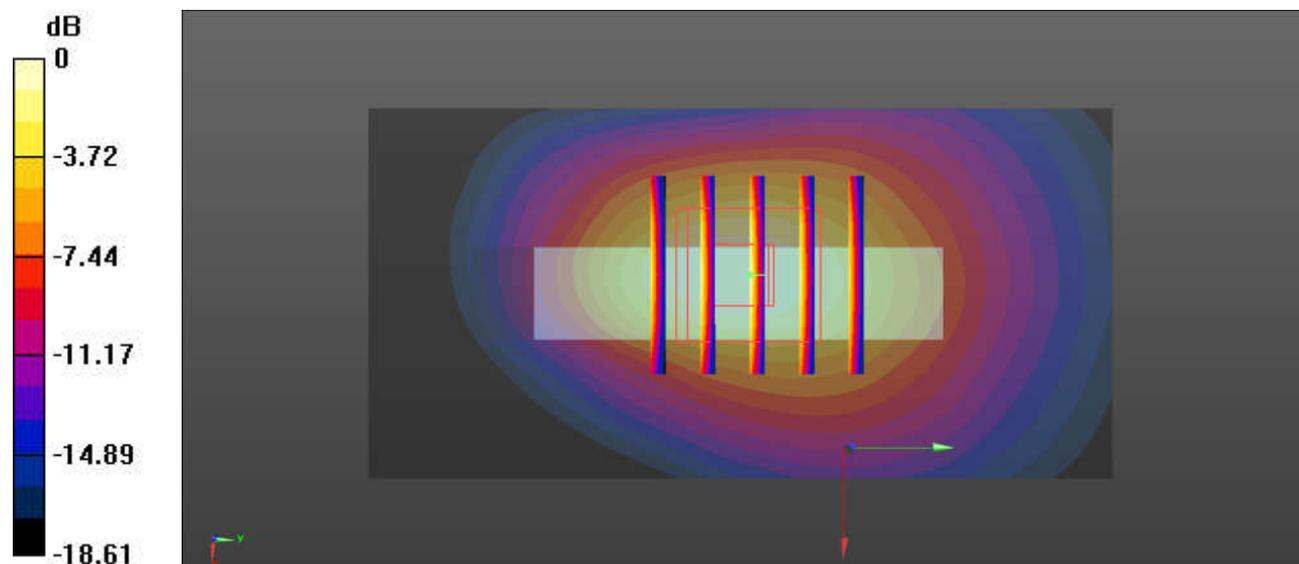

0 dB = 1.31 W/kg = 1.84 dBW/kg

### 02\_LTE Band 5\_10M\_QPSK\_1RB\_0Offset\_Back\_10mm\_Ch20525

Communication System: UID 0, LTE-FDD (0); Frequency: 836.5 MHz;Duty Cycle: 1:1  
Medium: HSL\_835 Medium parameters used:  $f = 836.5$  MHz;  $\sigma = 0.932$  S/m;  $\epsilon_r = 41.363$ ;  $\rho = 1000$  kg/m<sup>3</sup>

Ambient Temperature : 23.1 °C; Liquid Temperature : 22.7 °C

#### DASY5 Configuration:

- Probe: EX3DV4 - SN3935; ConvF(10.27, 10.27, 10.27); Calibrated: 2021.4.29
- Sensor-Surface: 1.4mm (Mechanical Surface Detection)
- Electronics: DAE4 Sn1650; Calibrated: 2021.6.9
- Phantom: SAM Twin Phantom; Type: SAM Twin; Serial: TP-1697
- Measurement SW: DASY52, Version 52.10 (4); SEMCAD X Version 14.6.14 (7483)

**Area Scan (71x91x1):** Interpolated grid: dx=1.500 mm, dy=1.500 mm

Maximum value of SAR (interpolated) = 0.534 W/kg

**Zoom Scan (6x6x7)/Cube 0:** Measurement grid: dx=8mm, dy=8mm, dz=5mm

Reference Value = 24.55 V/m; Power Drift = 0.12 dB

Peak SAR (extrapolated) = 0.600 W/kg

**SAR(1 g) = 0.426 W/kg; SAR(10 g) = 0.304 W/kg**

Maximum value of SAR (measured) = 0.538 W/kg

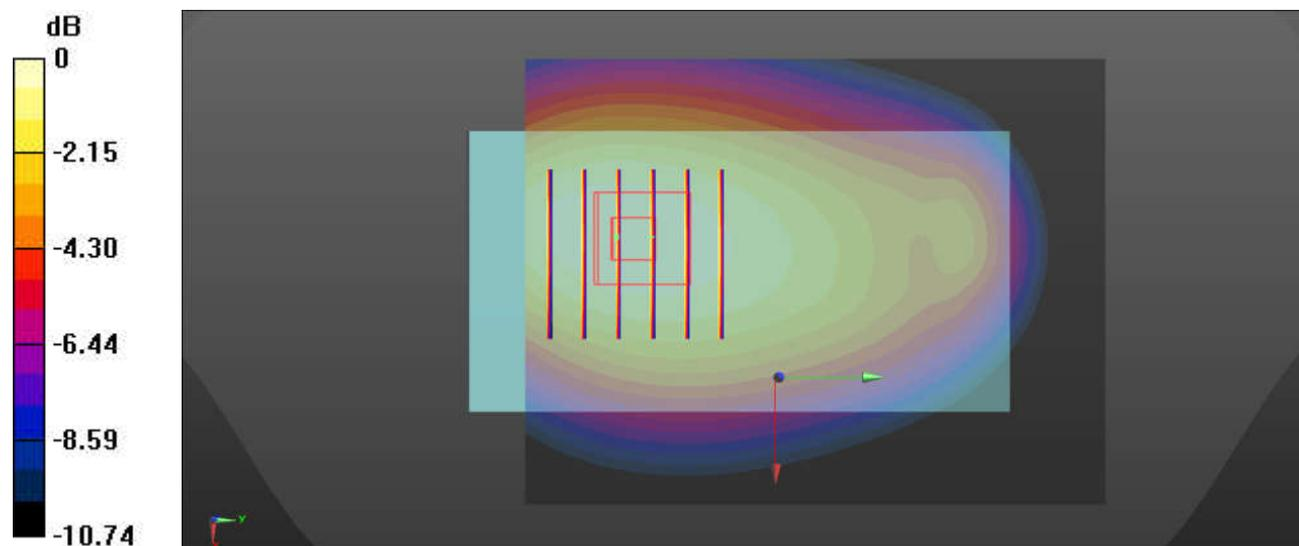

0 dB = 0.538 W/kg = -2.69 dBW/kg

### 03\_LTE Band 13\_10M\_QPSK\_1RB\_0Offset\_Front\_10mm\_Ch23230

Communication System: UID 0, LTE-FDD (0); Frequency: 782 MHz; Duty Cycle: 1:1  
Medium: HSL\_750 Medium parameters used:  $f = 782 \text{ MHz}$ ;  $\sigma = 0.912 \text{ S/m}$ ;  $\epsilon_r = 41.505$ ;  $\rho = 1000 \text{ kg/m}^3$

Ambient Temperature : 23.3 °C; Liquid Temperature : 22.8 °C

#### DASY5 Configuration:

- Probe: EX3DV4 - SN3935; ConvF(10.59, 10.59, 10.59); Calibrated: 2021.4.29
- Sensor-Surface: 1.4mm (Mechanical Surface Detection)
- Electronics: DAE4 Sn1650; Calibrated: 2021.6.9
- Phantom: SAM Twin Phantom; Type: SAM Twin; Serial: TP-1697
- Measurement SW: DASY52, Version 52.10 (4); SEMCAD X Version 14.6.14 (7483)

**Area Scan (61x101x1):** Interpolated grid:  $dx=1.500 \text{ mm}$ ,  $dy=1.500 \text{ mm}$   
Maximum value of SAR (interpolated) = 0.732 W/kg

**Zoom Scan (5x5x7)/Cube 0:** Measurement grid:  $dx=8\text{mm}$ ,  $dy=8\text{mm}$ ,  $dz=5\text{mm}$   
Reference Value = 29.57 V/m; Power Drift = 0.01 dB  
Peak SAR (extrapolated) = 0.819 W/kg  
**SAR(1 g) = 0.595 W/kg; SAR(10 g) = 0.433 W/kg**  
Maximum value of SAR (measured) = 0.742 W/kg

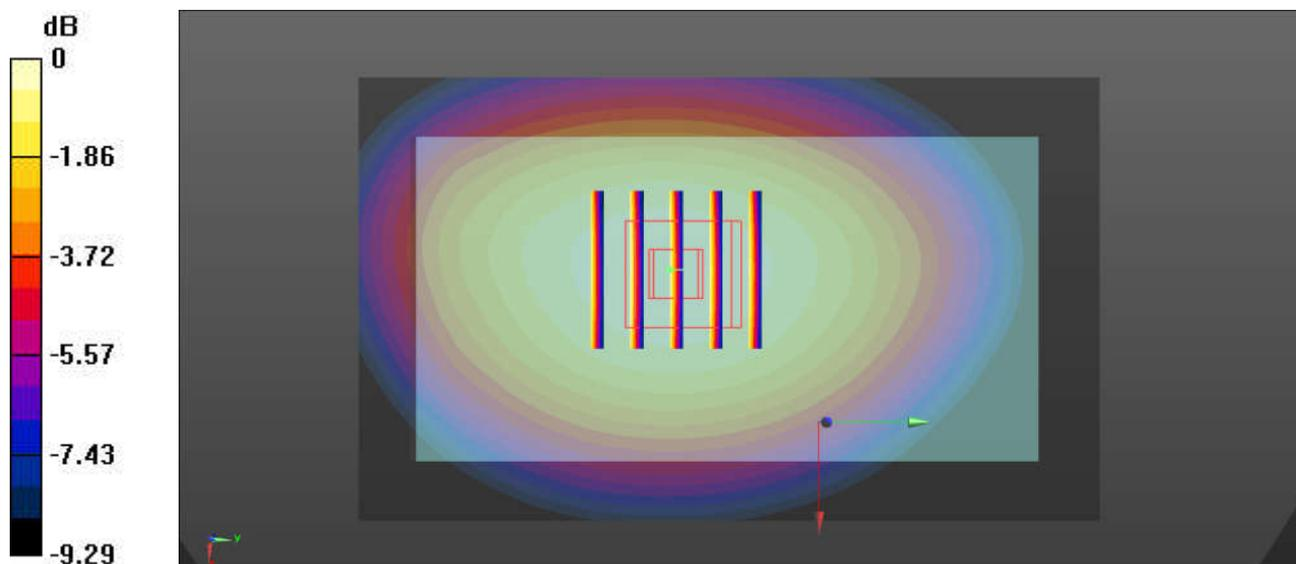

0 dB = 0.742 W/kg = -1.30 dBW/kg

### 04\_LTE Band 66\_20M\_QPSK\_1RB\_0Offset\_Left Side\_10mm\_Ch132322

Communication System: UID 0, LTE-FDD (0); Frequency: 1745 MHz; Duty Cycle: 1:1  
Medium: HSL\_1750 Medium parameters used:  $f = 1745$  MHz;  $\sigma = 1.348$  S/m;  $\epsilon_r = 40.023$ ;  $\rho = 1000$  kg/m<sup>3</sup>

Ambient Temperature : 23.4 °C; Liquid Temperature : 22.7 °C

#### DASY5 Configuration:

- Probe: EX3DV4 - SN3935; ConvF(8.9, 8.9, 8.9); Calibrated: 2021.4.29
- Sensor-Surface: 1.4mm (Mechanical Surface Detection)
- Electronics: DAE4 Sn1650; Calibrated: 2021.6.9
- Phantom: SAM Twin Phantom; Type: SAM Twin; Serial: TP-1697
- Measurement SW: DASY52, Version 52.10 (4); SEMCAD X Version 14.6.14 (7483)

**Area Scan (41x81x1):** Interpolated grid: dx=1.500 mm, dy=1.500 mm

Maximum value of SAR (interpolated) = 1.39 W/kg

**Zoom Scan (5x5x7)/Cube 0:** Measurement grid: dx=8mm, dy=8mm, dz=5mm

Reference Value = 3.029 V/m; Power Drift = 0.02 dB

Peak SAR (extrapolated) = 1.65 W/kg

**SAR(1 g) = 0.878 W/kg; SAR(10 g) = 0.456 W/kg**

Maximum value of SAR (measured) = 1.36 W/kg

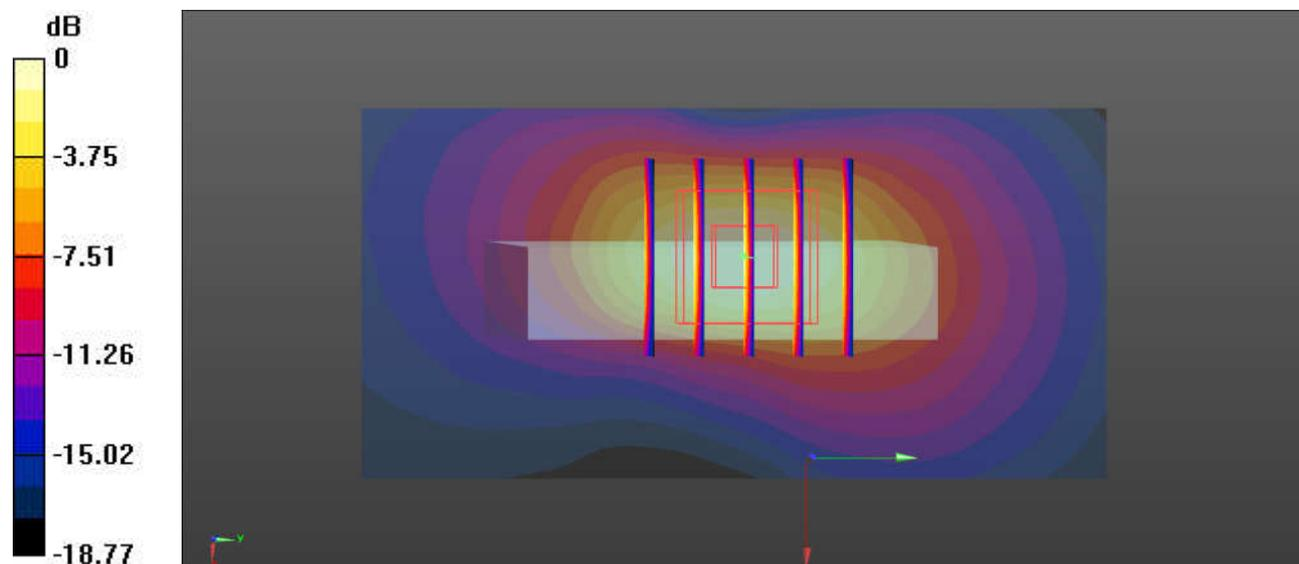

0 dB = 1.36 W/kg = 1.34 dBW/kg

**05\_LTE Band 48\_20M\_QPSK\_1RB\_0Offset\_Bottom Side\_10mm\_Ch55830**

Communication System: UID 0, LTE-TDD (0); Frequency: 3609 MHz; Duty Cycle: 1:1.59  
 Medium: HSL\_3700 Medium parameters used:  $f = 3609$  MHz;  $\sigma = 2.937$  S/m;  $\epsilon_r = 38.877$ ;  $\rho = 1000$  kg/m<sup>3</sup>  
 Ambient Temperature : 23.3 °C; Liquid Temperature : 22.7 °C

**DASY5 Configuration:**

- Probe: EX3DV4 - SN3935; ConvF(7.03, 7.03, 7.03); Calibrated: 2021.4.29
- Sensor-Surface: 1.4mm (Mechanical Surface Detection)
- Electronics: DAE4 Sn1650; Calibrated: 2021.6.9
- Phantom: SAM Twin Phantom; Type: SAM Twin; Serial: TP-1697
- Measurement SW: DASY52, Version 52.10 (4); SEMCAD X Version 14.6.14 (7483)

**Area Scan (51x151x1):** Interpolated grid: dx=1.000 mm, dy=1.000 mm  
 Maximum value of SAR (interpolated) = 0.717 W/kg

**Zoom Scan (7x7x7)/Cube 0:** Measurement grid: dx=4mm, dy=4mm, dz=1.4mm  
 Reference Value = 15.15 V/m; Power Drift = -0.02 dB  
 Peak SAR (extrapolated) = 0.980 W/kg  
**SAR(1 g) = 0.363 W/kg; SAR(10 g) = 0.140 W/kg**  
 Maximum value of SAR (measured) = 0.703 W/kg

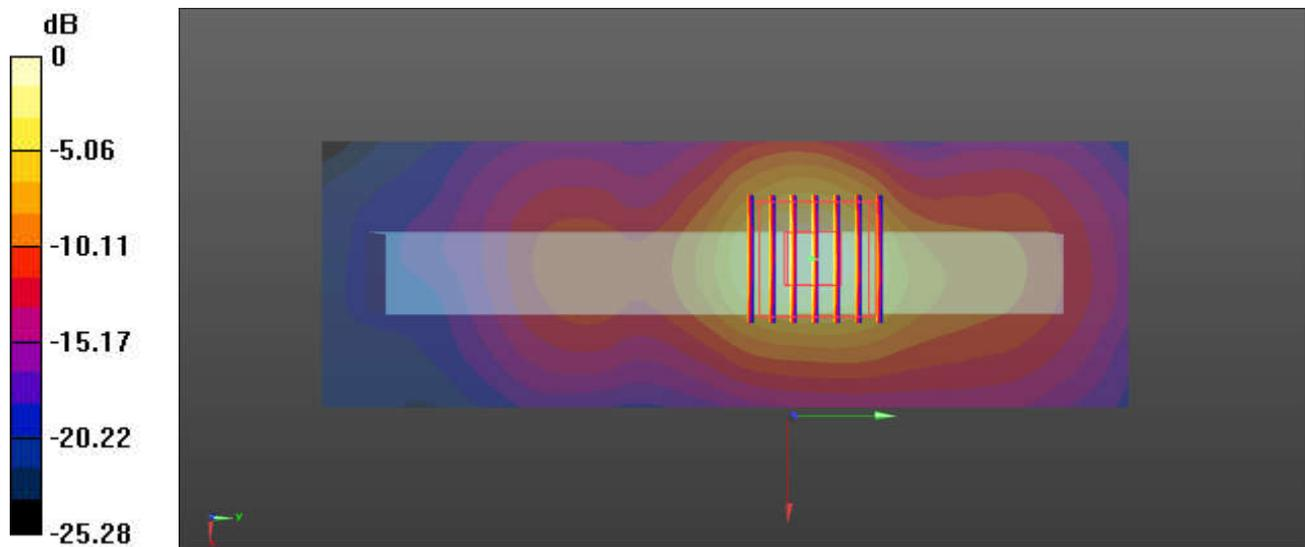

0 dB = 0.703 W/kg = -1.53 dBW/kg

**06\_FR1 N2\_20M\_QPSK\_1RB\_1Offset\_Left Side\_10mm\_Ch376000**

Communication System: UID 0, 5G NR (0); Frequency: 1880 MHz; Duty Cycle: 1:1  
Medium: HSL\_1900 Medium parameters used:  $f = 1880$  MHz;  $\sigma = 1.42$  S/m;  $\epsilon_r = 39.811$ ;  $\rho = 1000$  kg/m<sup>3</sup>

Ambient Temperature : 23.3 °C; Liquid Temperature : 22.9 °C

**DASY5 Configuration:**

- Probe: EX3DV4 - SN3935; ConvF(8.61, 8.61, 8.61); Calibrated: 2021.4.29
- Sensor-Surface: 1.4mm (Mechanical Surface Detection)
- Electronics: DAE4 Sn1650; Calibrated: 2021.6.9
- Phantom: SAM Twin Phantom; Type: SAM Twin; Serial: TP-1697
- Measurement SW: DASY52, Version 52.10 (4); SEMCAD X Version 14.6.14 (7483)

**Area Scan (41x81x1):** Interpolated grid: dx=1.500 mm, dy=1.500 mm

Maximum value of SAR (interpolated) = 1.40 W/kg

**Zoom Scan (5x5x7)/Cube 0:** Measurement grid: dx=8mm, dy=8mm, dz=5mm

Reference Value = 31.53 V/m; Power Drift = -0.04 dB

Peak SAR (extrapolated) = 1.68 W/kg

**SAR(1 g) = 0.894 W/kg; SAR(10 g) = 0.465 W/kg**

Maximum value of SAR (measured) = 1.38 W/kg

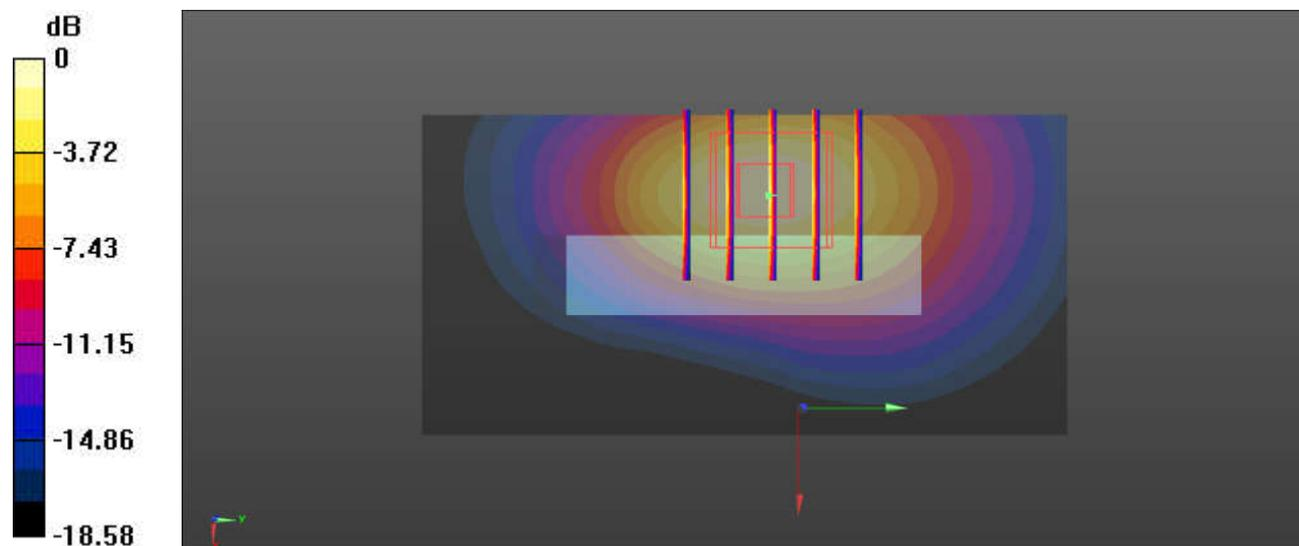

0 dB = 1.38 W/kg = 1.40 dBW/kg

**07\_FR1 N5\_20M\_QPSK\_1RB\_1Offset\_Front\_10mm\_Ch167300**

Communication System: UID 0, 5G NR (0); Frequency: 836.5 MHz; Duty Cycle: 1:1  
 Medium: HSL\_835 Medium parameters used:  $f = 836.5$  MHz;  $\sigma = 0.932$  S/m;  $\epsilon_r = 41.363$ ;  $\rho = 1000$  kg/m<sup>3</sup>  
 Ambient Temperature : 23.1 °C; Liquid Temperature : 22.7 °C

**DASY5 Configuration:**

- Probe: EX3DV4 - SN3935; ConvF(10.27, 10.27, 10.27); Calibrated: 2021.4.29
- Sensor-Surface: 1.4mm (Mechanical Surface Detection)
- Electronics: DAE4 Sn1650; Calibrated: 2021.6.9
- Phantom: SAM Twin Phantom; Type: SAM Twin; Serial: TP-1697
- Measurement SW: DASY52, Version 52.10 (4); SEMCAD X Version 14.6.14 (7483)

**Area Scan (61x101x1):** Interpolated grid: dx=1.500 mm, dy=1.500 mm  
 Maximum value of SAR (interpolated) = 1.04 W/kg

**Zoom Scan (5x5x7)/Cube 0:** Measurement grid: dx=8mm, dy=8mm, dz=5mm  
 Reference Value = 34.69 V/m; Power Drift = -0.03 dB  
 Peak SAR (extrapolated) = 1.15 W/kg  
**SAR(1 g) = 0.850 W/kg; SAR(10 g) = 0.623 W/kg**  
 Maximum value of SAR (measured) = 1.04 W/kg

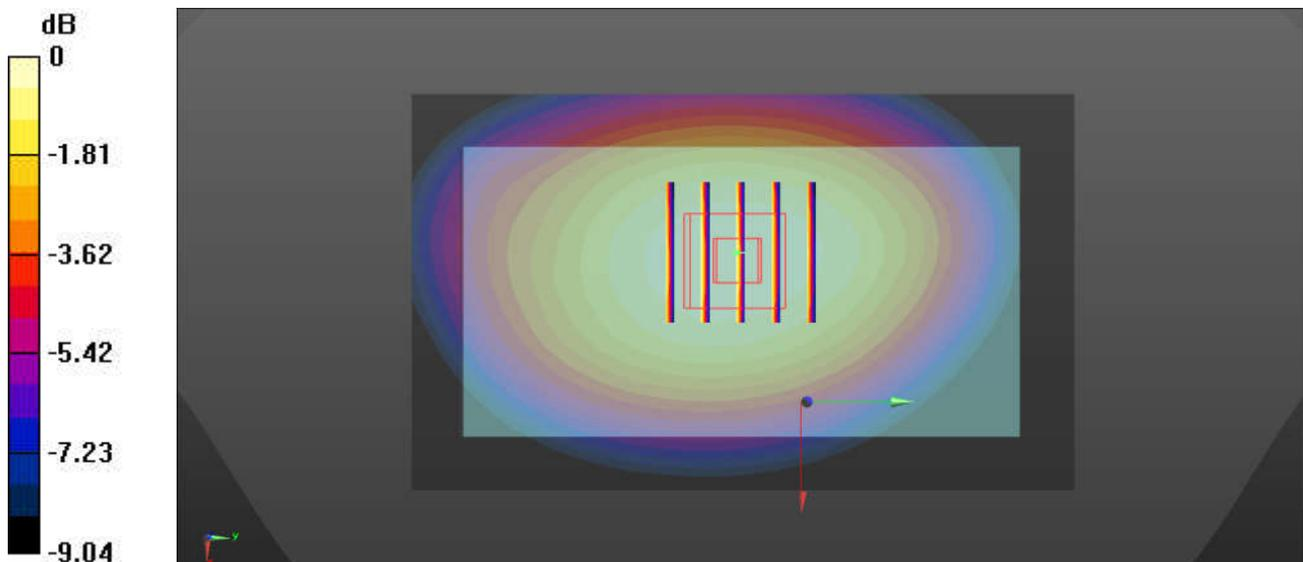

0 dB = 1.04 W/kg = 0.17 dBW/kg

### 08\_FR1 N66\_20M\_QPSK\_1RB\_1Offset\_Left Side\_10mm\_Ch349000

Communication System: UID 0, 5G NR (0); Frequency: 1745 MHz; Duty Cycle: 1:1  
Medium: HSL\_1750 Medium parameters used:  $f = 1745$  MHz;  $\sigma = 1.348$  S/m;  $\epsilon_r = 40.023$ ;  $\rho = 1000$  kg/m<sup>3</sup>

Ambient Temperature : 23.4 °C; Liquid Temperature : 22.7 °C

#### DASY5 Configuration:

- Probe: EX3DV4 - SN3935; ConvF(8.9, 8.9, 8.9); Calibrated: 2021.4.29
- Sensor-Surface: 1.4mm (Mechanical Surface Detection)
- Electronics: DAE4 Sn1650; Calibrated: 2021.6.9
- Phantom: SAM Twin Phantom; Type: SAM Twin; Serial: TP-1697
- Measurement SW: DASY52, Version 52.10 (4); SEMCAD X Version 14.6.14 (7483)

**Area Scan (41x81x1):** Interpolated grid: dx=1.500 mm, dy=1.500 mm

Maximum value of SAR (interpolated) = 1.40 W/kg

**Zoom Scan (5x5x7)/Cube 0:** Measurement grid: dx=8mm, dy=8mm, dz=5mm

Reference Value = 32.77 V/m; Power Drift = 0.04 dB

Peak SAR (extrapolated) = 1.67 W/kg

**SAR(1 g) = 0.911 W/kg; SAR(10 g) = 0.477 W/kg**

Maximum value of SAR (measured) = 1.38 W/kg

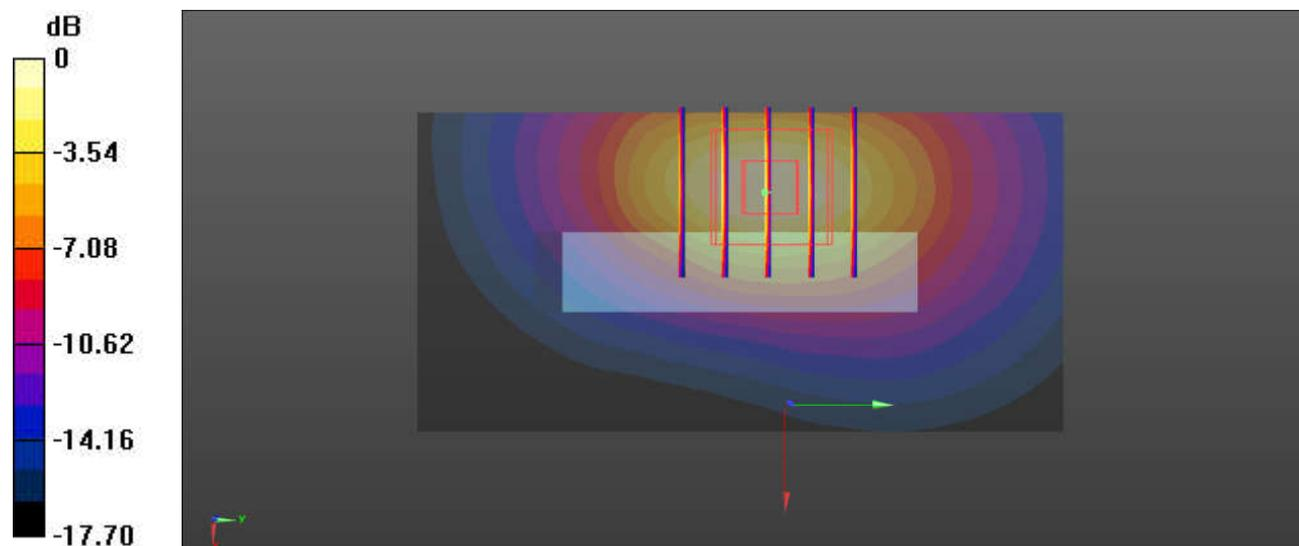

0 dB = 1.38 W/kg = 1.40 dBW/kg

**09\_FR1 N77\_100M\_QPSK\_1RB\_1Offset\_Bottom Side\_10mm\_Ch656000**

Communication System: UID 0, 5G NR (0); Frequency: 3840 MHz; Duty Cycle: 1:1  
Medium: HSL\_3900 Medium parameters used:  $f = 3840$  MHz;  $\sigma = 3.163$  S/m;  $\epsilon_r = 38.504$ ;  $\rho = 1000$  kg/m<sup>3</sup>  
Ambient Temperature : 23.3 °C; Liquid Temperature : 22.8 °C

**DASY5 Configuration:**

- Probe: EX3DV4 - SN3935; ConvF(6.99, 6.99, 6.99); Calibrated: 2021.4.29
- Sensor-Surface: 1.4mm (Mechanical Surface Detection)
- Electronics: DAE4 Sn1650; Calibrated: 2021.6.9
- Phantom: SAM Twin Phantom; Type: SAM Twin; Serial: TP-1697
- Measurement SW: DASY52, Version 52.10 (4); SEMCAD X Version 14.6.14 (7483)

**Area Scan (51x141x1):** Interpolated grid: dx=1.000 mm, dy=1.000 mm  
Maximum value of SAR (interpolated) = 0.621 W/kg

**Zoom Scan (7x7x7)/Cube 0:** Measurement grid: dx=4mm, dy=4mm, dz=1.4mm  
Reference Value = 11.36 V/m; Power Drift = -0.07 dB  
Peak SAR (extrapolated) = 0.821 W/kg  
**SAR(1 g) = 0.329 W/kg; SAR(10 g) = 0.146 W/kg**  
Maximum value of SAR (measured) = 0.598 W/kg

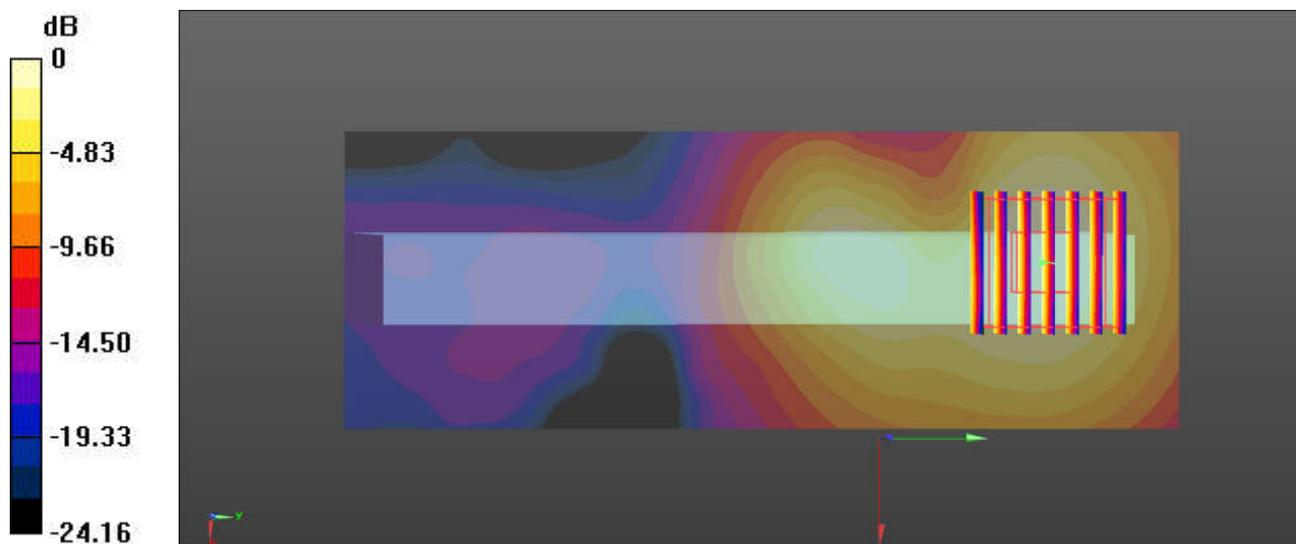

0 dB = 0.598 W/kg = -2.23 dBW/kg

### 10\_WLAN2.4GHz\_802.11b 1Mbps\_Bottom Side\_10mm\_Ch11

Communication System: UID 0, WLAN2.4GHz (0); Frequency: 2462 MHz; Duty Cycle: 1:1  
Medium: HSL\_2450 Medium parameters used:  $f = 2462$  MHz;  $\sigma = 1.816$  S/m;  $\epsilon_r = 40.549$ ;  $\rho = 1000$  kg/m<sup>3</sup>

Ambient Temperature : 23.2 °C; Liquid Temperature : 22.9 °C

#### DASY5 Configuration:

- Probe: EX3DV4 - SN3935; ConvF(7.86, 7.86, 7.86); Calibrated: 2021.4.29
- Sensor-Surface: 1.4mm (Mechanical Surface Detection)
- Electronics: DAE4 Sn1650; Calibrated: 2021.6.9
- Phantom: SAM Twin Phantom; Type: SAM Twin; Serial: TP-1697
- Measurement SW: DASY52, Version 52.10 (4); SEMCAD X Version 14.6.14 (7483)

**Area Scan (41x131x1):** Interpolated grid: dx=1.200 mm, dy=1.200 mm  
Maximum value of SAR (interpolated) = 0.475 W/kg

**Zoom Scan (7x7x7)/Cube 0:** Measurement grid: dx=5mm, dy=5mm, dz=5mm  
Reference Value = 16.45 V/m; Power Drift = -0.03 dB  
Peak SAR (extrapolated) = 0.565 W/kg  
**SAR(1 g) = 0.278 W/kg; SAR(10 g) = 0.133 W/kg**  
Maximum value of SAR (measured) = 0.451 W/kg

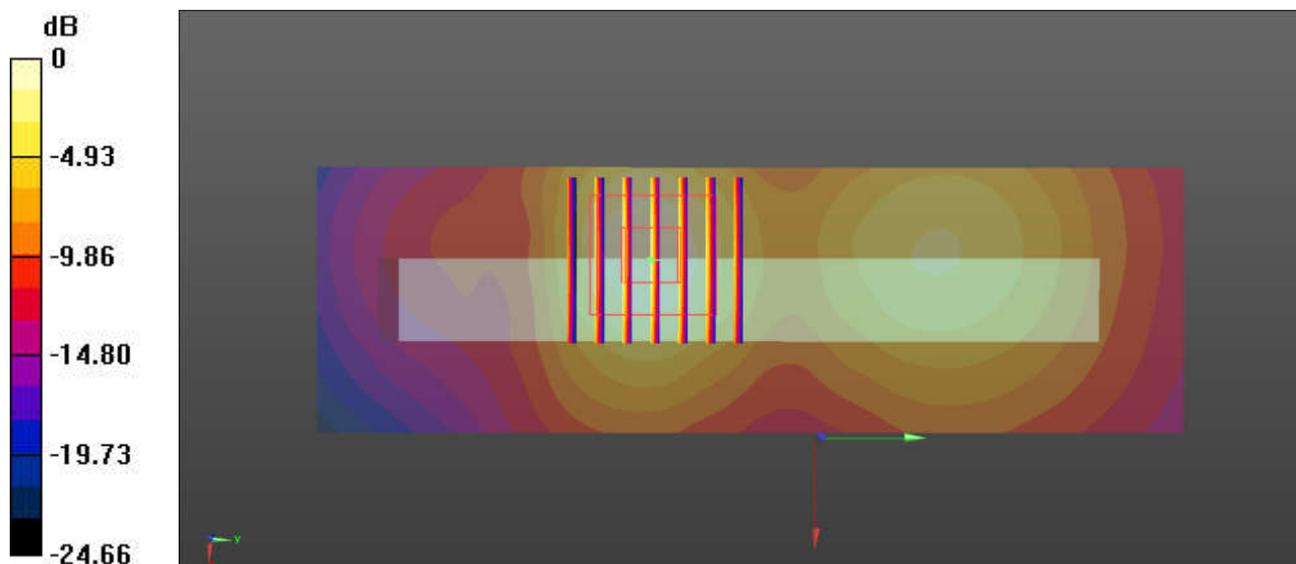

0 dB = 0.451 W/kg = -3.46 dBW/kg

### 11\_WLAN5GHz\_802.11n-HT40 MCS0\_Bottom Side\_10mm\_Ch38

Communication System: UID 0, WLAN5GHz (0); Frequency: 5190 MHz; Duty Cycle: 1:1  
Medium: HSL\_5000 Medium parameters used:  $f = 5190$  MHz;  $\sigma = 4.538$  S/m;  $\epsilon_r = 36.063$ ;  $\rho = 1000$  kg/m<sup>3</sup>

Ambient Temperature : 23.2 °C; Liquid Temperature : 22.7 °C

#### DASY5 Configuration:

- Probe: EX3DV4 - SN3935; ConvF(5.04, 5.04, 5.04); Calibrated: 2021.4.29
- Sensor-Surface: 1.4mm (Mechanical Surface Detection)
- Electronics: DAE4 Sn1650; Calibrated: 2021.6.9
- Phantom: SAM Twin Phantom; Type: SAM Twin; Serial: TP-1697
- Measurement SW: DASY52, Version 52.10 (4); SEMCAD X Version 14.6.14 (7483)

**Area Scan (61x151x1):** Interpolated grid: dx=1.000 mm, dy=1.000 mm

Maximum value of SAR (interpolated) = 0.596 W/kg

**Zoom Scan (9x9x7)/Cube 0:** Measurement grid: dx=4mm, dy=4mm, dz=1.4mm

Reference Value = 11.96 V/m; Power Drift = 0.04 dB

Peak SAR (extrapolated) = 0.906 W/kg

**SAR(1 g) = 0.248 W/kg; SAR(10 g) = 0.097 W/kg**

Maximum value of SAR (measured) = 0.587 W/kg

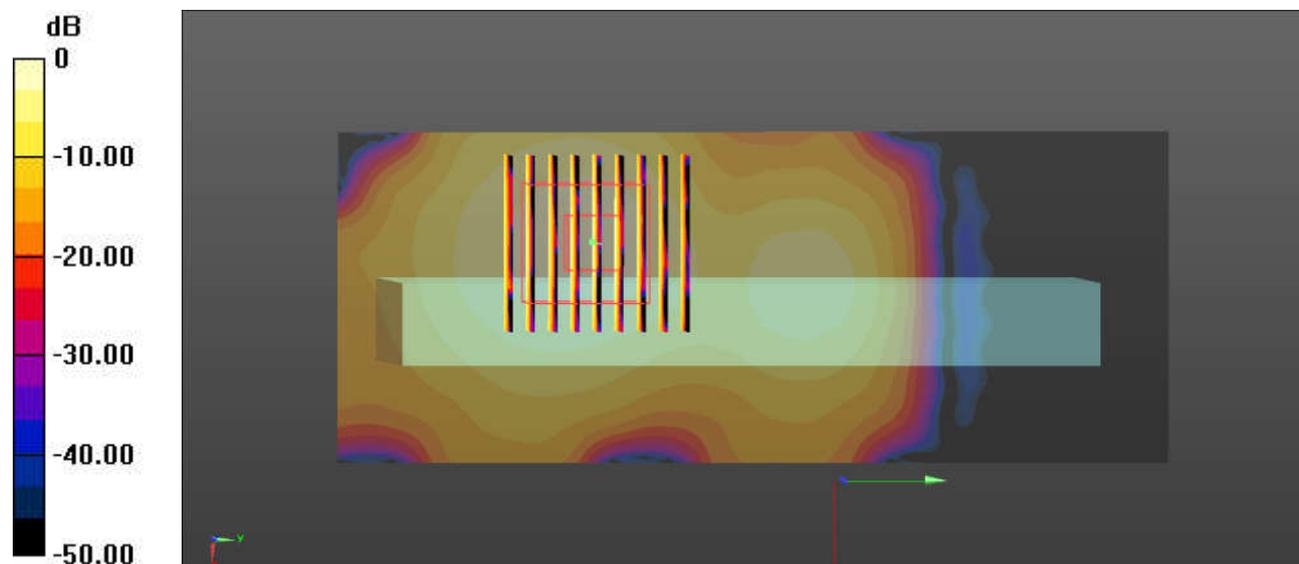

0 dB = 0.587 W/kg = -2.31 dBW/kg

### 12\_WLAN5GHz\_802.11n-HT40 MCS0\_Front\_10mm\_Ch159

Communication System: UID 0, WLAN5GHz (0); Frequency: 5795 MHz; Duty Cycle: 1:1  
Medium: HSL\_5000 Medium parameters used:  $f = 5795$  MHz;  $\sigma = 5.215$  S/m;  $\epsilon_r = 35.148$ ;  $\rho = 1000$  kg/m<sup>3</sup>

Ambient Temperature : 23.4 °C; Liquid Temperature : 22.6 °C

#### DASY5 Configuration:

- Probe: EX3DV4 - SN3935; ConvF(4.71, 4.71, 4.71); Calibrated: 2021.4.29
- Sensor-Surface: 1.4mm (Mechanical Surface Detection)
- Electronics: DAE4 Sn1650; Calibrated: 2021.6.9
- Phantom: SAM Twin Phantom; Type: SAM Twin; Serial: TP-1697
- Measurement SW: DASY52, Version 52.10 (4); SEMCAD X Version 14.6.14 (7483)

**Area Scan (91x81x1):** Interpolated grid: dx=1.000 mm, dy=1.000 mm

Maximum value of SAR (interpolated) = 0.348 W/kg

**Zoom Scan (9x9x7)/Cube 0:** Measurement grid: dx=4mm, dy=4mm, dz=1.4mm

Reference Value = 8.830 V/m; Power Drift = -0.04 dB

Peak SAR (extrapolated) = 0.607 W/kg

**SAR(1 g) = 0.144 W/kg; SAR(10 g) = 0.051 W/kg**

Maximum value of SAR (measured) = 0.349 W/kg

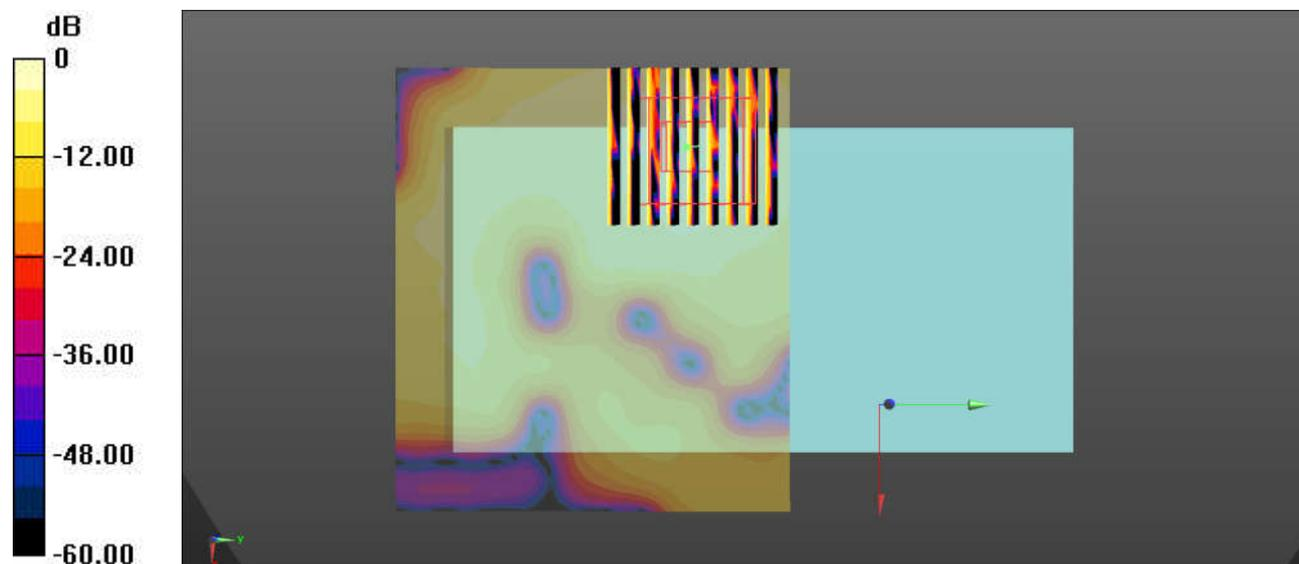

0 dB = 0.349 W/kg = -4.57 dBW/kg



**Appendix C. DAS Y Calibration Certificate**

The DAS Y calibration certificates are shown as follows.



In Collaboration with  
**s p e a g**  
CALIBRATION LABORATORY



中国认可  
国际互认  
校准  
CALIBRATION  
CNAS L0570

Add: No.51 Xueyuan Road, Haidian District, Beijing, 100191, China  
Tel: +86-10-62304633-2079 Fax: +86-10-62304633-2504  
E-mail: cttl@chinattl.com http://www.chinattl.cn

Client **Sporton**

Certificate No: **Z19-60081**

## CALIBRATION CERTIFICATE

Object **D750V3 - SN: 1087**

Calibration Procedure(s) **FF-Z11-003-01**  
**Calibration Procedures for dipole validation kits**

Calibration date: **March 27, 2019**

This calibration Certificate documents the traceability to national standards, which realize the physical units of measurements(SI). The measurements and the uncertainties with confidence probability are given on the following pages and are part of the certificate.

All calibrations have been conducted in the closed laboratory facility: environment temperature(22±3)°C and humidity<70%.

Calibration Equipment used (M&TE critical for calibration)

Primary Standards	ID #	Cal Date(Calibrated by, Certificate No.)	Scheduled Calibration
Power Meter NRP2	106277	20-Aug-18 (CTTL, No.J18X06862)	Aug-19
Power sensor NRP8S	104291	20-Aug-18 (CTTL, No.J18X06862)	Aug-19
Reference Probe EX3DV4	SN 3617	31-Jan-19(SPEAG,No.EX3-3617_Jan19)	Jan-20
DAE4	SN 1331	06-Feb-19(SPEAG,No.DAE4-1331_Feb19)	Feb-20
Secondary Standards	ID #	Cal Date(Calibrated by, Certificate No.)	Scheduled Calibration
Signal Generator E4438C	MY49071430	23-Jan-19 (CTTL, No.J19X00336)	Jan-20
NetworkAnalyzer E5071C	MY46110673	24-Jan-19 (CTTL, No.J19X00547)	Jan-20

	Name	Function	Signature
Calibrated by:	Zhao Jing	SAR Test Engineer	
Reviewed by:	Lin Hao	SAR Test Engineer	
Approved by:	Qi Dianyuan	SAR Project Leader	

Issued: March 29, 2019

This calibration certificate shall not be reproduced except in full without written approval of the laboratory.



In Collaboration with

**s p e a g**  
CALIBRATION LABORATORY

Add: No.51 Xueyuan Road, Haidian District, Beijing, 100191, China  
Tel: +86-10-62304633-2079 Fax: +86-10-62304633-2504  
E-mail: cttl@chinattl.com http://www.chinattl.cn

### Glossary:

TSL	tissue simulating liquid
ConvF	sensitivity in TSL / NORM <sub>x,y,z</sub>
N/A	not applicable or not measured

### Calibration is Performed According to the Following Standards:

- IEEE Std 1528-2013, "IEEE Recommended Practice for Determining the Peak Spatial-Averaged Specific Absorption Rate (SAR) in the Human Head from Wireless Communications Devices: Measurement Techniques", June 2013
- IEC 62209-1, "Measurement procedure for assessment of specific absorption rate of human exposure to radio frequency fields from hand-held and body-mounted wireless communication devices- Part 1: Device used next to the ear (Frequency range of 300MHz to 6GHz)", July 2016
- IEC 62209-2, "Procedure to measure the Specific Absorption Rate (SAR) For wireless communication devices used in close proximity to the human body (frequency range of 30MHz to 6GHz)", March 2010
- KDB865664, SAR Measurement Requirements for 100 MHz to 6 GHz

### Additional Documentation:

- DASY4/5 System Handbook

### Methods Applied and Interpretation of Parameters:

- Measurement Conditions:** Further details are available from the Validation Report at the end of the certificate. All figures stated in the certificate are valid at the frequency indicated.
- Antenna Parameters with TSL:** The dipole is mounted with the spacer to position its feed point exactly below the center marking of the flat phantom section, with the arms oriented parallel to the body axis.
- Feed Point Impedance and Return Loss:** These parameters are measured with the dipole positioned under the liquid filled phantom. The impedance stated is transformed from the measurement at the SMA connector to the feed point. The Return Loss ensures low reflected power. No uncertainty required.
- Electrical Delay:** One-way delay between the SMA connector and the antenna feed point. No uncertainty required.
- SAR measured:** SAR measured at the stated antenna input power.
- SAR normalized:** SAR as measured, normalized to an input power of 1 W at the antenna connector.
- SAR for nominal TSL parameters:** The measured TSL parameters are used to calculate the nominal SAR result.

The reported uncertainty of measurement is stated as the standard uncertainty of Measurement multiplied by the coverage factor  $k=2$ , which for a normal distribution Corresponds to a coverage probability of approximately 95%.



Add: No.51 Xueyuan Road, Haidian District, Beijing, 100191, China  
 Tel: +86-10-62304633-2079 Fax: +86-10-62304633-2504  
 E-mail: cttl@chinattl.com http://www.chinattl.cn

### Measurement Conditions

DASY system configuration, as far as not given on page 1.

DASY Version	DASY52	52.10.2.1495
Extrapolation	Advanced Extrapolation	
Phantom	Triple Flat Phantom 5.1C	
Distance Dipole Center - TSL	15 mm	with Spacer
Zoom Scan Resolution	dx, dy, dz = 5 mm	
Frequency	750 MHz ± 1 MHz	

### Head TSL parameters

The following parameters and calculations were applied.

	Temperature	Permittivity	Conductivity
Nominal Head TSL parameters	22.0 °C	41.9	0.89 mho/m
Measured Head TSL parameters	(22.0 ± 0.2) °C	43.0 ± 6 %	0.90 mho/m ± 6 %
Head TSL temperature change during test	<1.0 °C	----	----

### SAR result with Head TSL

SAR averaged over 1 cm <sup>3</sup> (1 g) of Head TSL	Condition	
SAR measured	250 mW input power	2.10 W/kg
SAR for nominal Head TSL parameters	normalized to 1W	<b>8.36 W/kg ± 18.8 % (k=2)</b>
SAR averaged over 10 cm <sup>3</sup> (10 g) of Head TSL	Condition	
SAR measured	250 mW input power	1.42 W/kg
SAR for nominal Head TSL parameters	normalized to 1W	<b>5.65 W/kg ± 18.7 % (k=2)</b>

### Body TSL parameters

The following parameters and calculations were applied.

	Temperature	Permittivity	Conductivity
Nominal Body TSL parameters	22.0 °C	55.5	0.96 mho/m
Measured Body TSL parameters	(22.0 ± 0.2) °C	56.9 ± 6 %	0.94 mho/m ± 6 %
Body TSL temperature change during test	<1.0 °C	----	----

### SAR result with Body TSL

SAR averaged over 1 cm <sup>3</sup> (1 g) of Body TSL	Condition	
SAR measured	250 mW input power	2.09 W/kg
SAR for nominal Body TSL parameters	normalized to 1W	<b>8.58 W/kg ± 18.8 % (k=2)</b>
SAR averaged over 10 cm <sup>3</sup> (10 g) of Body TSL	Condition	
SAR measured	250 mW input power	1.41 W/kg
SAR for nominal Body TSL parameters	normalized to 1W	<b>5.75 W/kg ± 18.7 % (k=2)</b>