

**SPECIFICATION FOR APPROVAL**

**CUSTOMER: Shenzhen Aodehong Electronic Technology Co., Ltd.**

---

**CUST P/N:**

---

**FINE P/N: G4511-6.5uH single-coil 0.08\*105P\*12TS**

---

**DESC:  $\Phi$  43.5MMX5.0MMX0.8MM dual slot**

---

**DATE: 2022/11/01**

---

**Version: A.0**

---

PREPARED BY	CHECKED BY	APPROVED BY	CUSTOMER APPROVE
黄燕铭	宁元安	黄锦华	

**Shenzhen Songdao Technology Co., Ltd.**

Factory Address: 8th Floor, Building 2, No. 123 Sanjia High tech Industrial Park, Junfa 3rd Road, Dongkeng Town, Dongguan

TEL: 13728755750

FAX: 0755-84526500

E-mail: [506388681@qq.com](mailto:506388681@qq.com)

Rev.	Before Change	After Change	Change Date	Approved By
A.0	New issue	----	2018/07/24	黄锦华

SPECIFICATION

DESC	Φ 13.5x39-6.5uH-0.08x105P-20mm-43.5C	Rev: A.0	CUST:	XXX
			CUST P/N:	

一、DIMENSION:(mm)

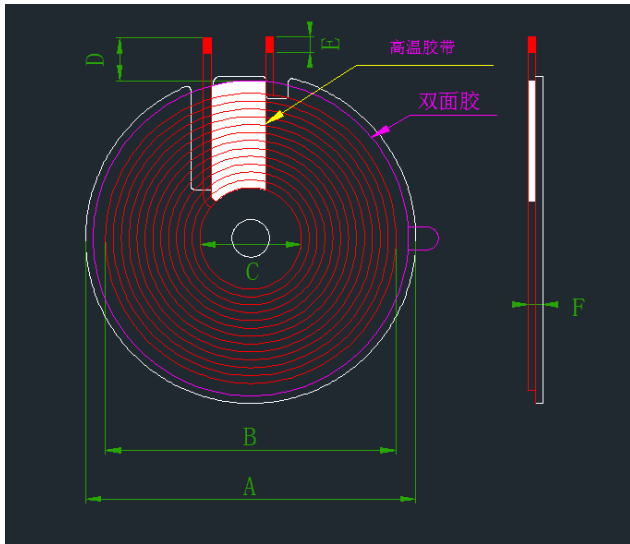

A	43.5.0±0.5
B	39±1
C	13.5±0.5
D	20±2
E	3±2
F	2±0.2

Remark:

- 1.Cross over outgoing line;
- 2.Outgoing line position wrapping 8mm(ref)width high-temperature adhesive paper 1-2Ts;
- 3.Coil with circular hard magnetic plate and slot, Magnetic plate size:43.5±0.5mm,Inner hole:5.3mm,Thickness:0.8±0.2 mm, Adhesive。

二、SCHEMATIC DIAGRAM:

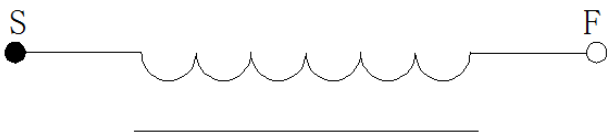

三、Winding Specification:

NO.	TERMINAL		WIRE	Turns	Winding Direction
1	S	F	Wrapped wire 0.08*105P	12Ts	CCW

四、ELECTRICAL CHARACTERISTICS:

TEMPERATURE:25±10°C, RELATIVE HUMIDITY:65±20%

NO.	ITEM	TERMINAL	SPECIFICATION	TEST FREQUENCY	TEST EQUIPMENTS
1	IND.	S-F	3.8uH ±20% Individual coil	100KHz/1.0V	LCZ METER 1062B
2	IND.	S-F	6.5uH ±10% add magnetic plate	100KHz/1.0V	LCZ METER 1062B
3	Q value	S-F	≥55		
4	DCR	S-F	≤48mΩ		LCZ METER 502B

PREPARED BY/DATE	CHECKED BY/DATE
黄燕铭 2022/11/01	黄锦华 2022/11/01