

SPECIFICATION FOR APPROVALCUSTOMER: **Dongguan Kafulle Electronics Co., Ltd.**

CUST P/N:

FINE P/N: **Apple watch transmit coil 8.1UH
0.08*24P*14Ts Soft magnetic plate**

DESC:

DATE: **2022/11/08**Version: **A.0**

PREPARED BY	CHECKED BY	APPROVED BY	CUSTOMER APPROVE
黄燕铭	宁元安	黄锦华	

Shenzhen Songdao Technology Co., Ltd.

Factory Address: 8th Floor, Building 2, No. 123 Sanjia High tech Industrial Park, Junfa
3rd Road, Dongkeng Town, Dongguan

TEL: 13728755750

FAX: 0755-84526500

E-mail: 506388681@qq.com

Version Change History

Rev.	Before Change	After Change	Change Date	Approved By
A.0	New issue	----	2018/03/09	黄锦华

SPECIFICATION

DESC	15*21.5-8.1UH-8MM-25C	Rev: A.0	CUST:	XXX
------	-----------------------	----------	-------	------------

CUST P/N:

一、尺寸 DIMENSION:(mm)

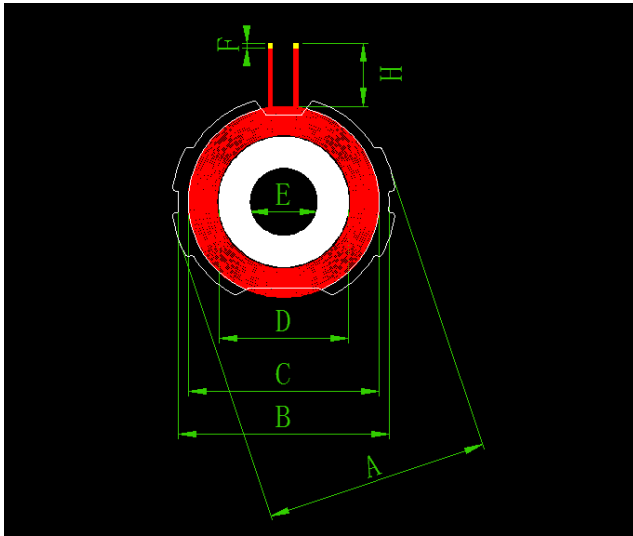

A	25±1
B	23.6±0.5
C	21.5±0.5
D	14.5±0.3
E	7.7±0.05
F	3±2
H	8±2

Remark:

- 1.Cross over outgoing line;
- 2.Outgoing line position wrapping mm(ref)width high-temperature adhesive paper Ts;
- 3.Coil with circular soft magnetic plate with notches at both ends, Magnetic plate size:25±1mm,Inner hole 7.7mm,Thickness:2.8±0.2mm。
- 4.Pack7.5*2.2mm, N52 magnet, with adhesive

二、SCHEMATIC DIAGRAM:

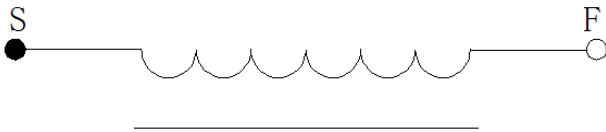

三、Winding Specification:

NO.	TERMINAL		WIRE	Turns	Winding Direction
1	S	F	Enamel-insulated wire0.08*24P	14Ts	CCW

四、ELECTRICAL CHARACTERISTICS:

TEMPERATURE:25±10°C, RELATIVE HUMIDITY:65±20%

NO.	ITEM	TERMINAL	SPECIFICATION	TEST FREQUENCY	TEST EQUIPMENTS
1	IND.	S-F	4.0uH ±10% Individual coil	1KHz/0.3V	LCZ METER 1062B
2	IND.	S-F	8.1uH ±10% Individual coil	1KHz/0.3V	LCZ METER 1062B
3	DCR	S-F	≤137mΩ	1KHz/0.3V	LCZ METER 502B
4	Q	S-F	≥25	1KHz/0.3V	LCZ METER 502B

PREPARED BY/DATE

CHECKED BY/DATE

黄燕铭 2022/11/08

黄锦华 2022/11/08