

样品承认书

sample approval sheet

客户名称customer name： 深圳市澳德鸿电子有限公司

客户料号Customer Material Number :EXQ-40MM00002

物料名称name of material： 无线充发射线圈Wireless charging transmitter coil

品牌名称 brand name： 捷利通科技

规格型号 specifications and models : T40*5.0*0.5 6.5uH 10%

版本 versions： 1

生产批号/料号Production lot/material number：

送样日期 datelanded： 2022-01-22

签样日期 Sample signing date：

客户承认： Customer recognition				供应商承认： Supplier recognition		
采购部 purchasing department	工程部 engineering department	审核 audit	批注 annotation	拟定 protocol	审核 audit	批准 ratify
				陈翠珠	李书坡	张军

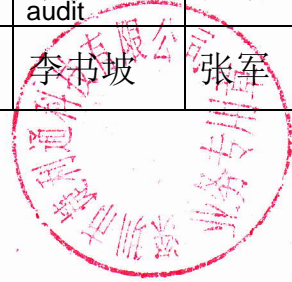

1. 基本规格

Basic specification

NO	产品名称 product name	型号/规格 type specification	适用机型 applicable models	制造商 manufacturer	备注 remark
1	Wireless charging transmitter coil	40*5.0*0.5			

2. 外型尺寸(单位:mm)

external dimension

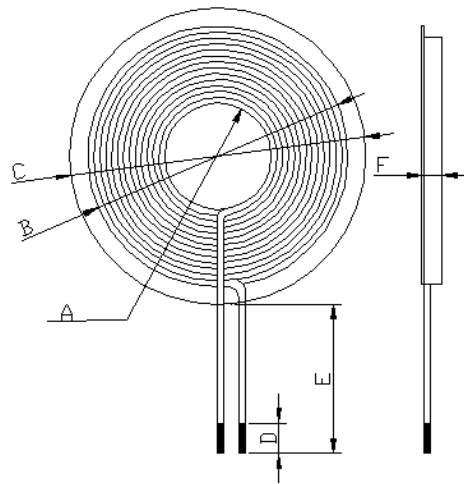

ITEM	A	B	C	D	E	F
SPEC.	20 ±0.5	38 ±0.5	40±0.5	2±2	30±2	2.0max

3. 原理图

schematic diagram

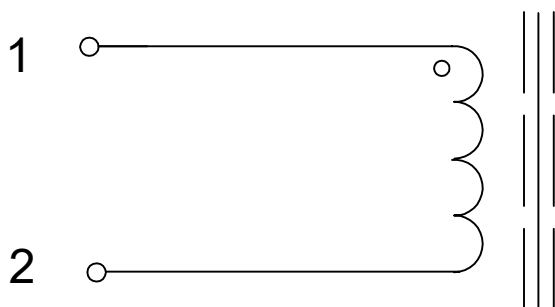

4. 绕制工艺

Winding process

N0	绕组 winding	线规 guage	起点 origin	尾点 tail point	匝数	包胶圈数 number of turns	绕线方式 way of winding
1	N1	0.08*24*2P	1	2	10Ts		
2							
3							
4							

5. 电性能参数

5.1 测试条件:环境湿度:65+20% 环境温度:25+5 °C

5.2 电感量:L=6.5uH± 10% at 100khz, 1v;(以圈数为准)。

5.3 DCR: 70m Ωmax

5.4 Max Current: 2.0A

5.5 Q值: 70 (min)

Electrical property parameter

5.1 Test conditions: Ambient humidity: 65+20% Ambient temperature: 25+5 °C

5.2 Inductance: L=6.5uH± 10%at 100khz, 1v; (based on the number of turns)

5.3 DCR:70M max

5.4 Max Current: 2.0A

5.5 Q value 70 (min)

六. Construction

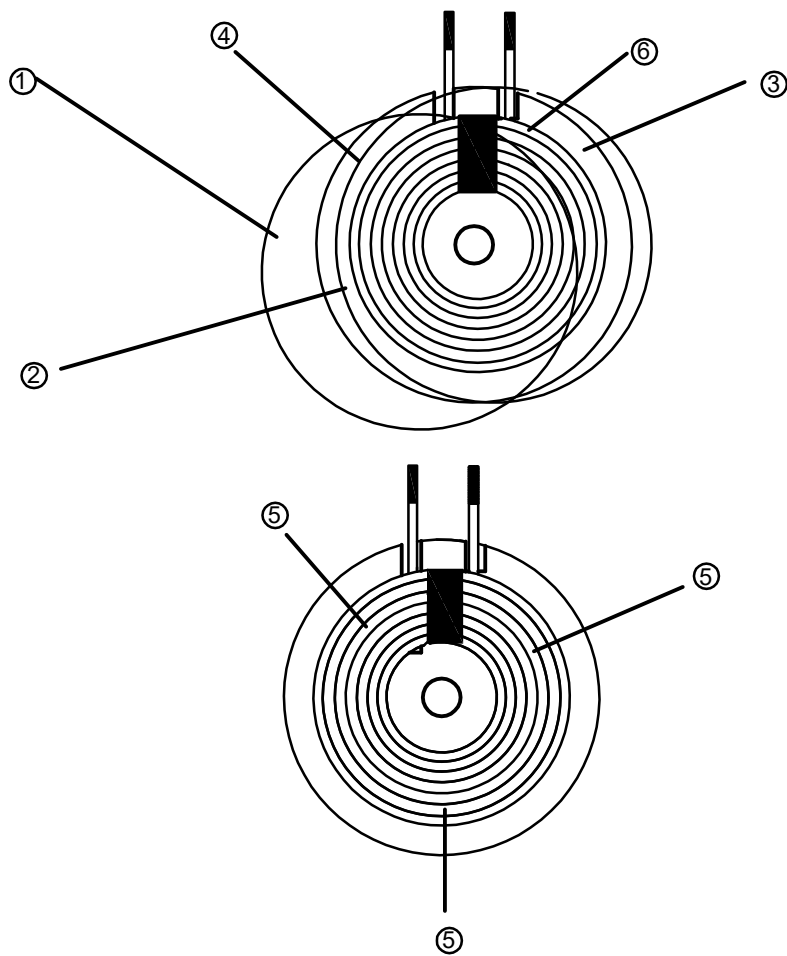

NO	Material Name
1	背胶 Adhesive
2	铁氧体片 ferrite sheet
3	线圈 coil
4	
5	胶水 glue
6	固定胶纸 Fixed adhesive paper