

SPECIFICATION FOR APPROVAL

CUSTOMER: **Shenzhen Aodehong Electronic Technology Co., LTD**

CUST P/N:

FINE P/N: **G4511-6.5uH single coil 0.08*105P*12TS**

DESC: **Φ43.5MMX5.0MMX0.8MM double-groove**

DATE: **November, 1,2022**

Version: **A.0**

PREPARED BY	CHECKED BY	APPROVED BY	CUSTOMER APPROVE
Yanming Huang	Yuanan Ning	Jinhua Huang	

Shenzhen Songdao Technology Co., LTD

Add: 8th Floor, Building 2, Sanjia High-tech Industrial Park, No.123 Junfa Third Road, Dongkeng Town, Dongguan City

TEL: 13728755750

FAX: 0755-84526500

E-mail: 506388681@qq.com

Rev.	Before Change	After Change	Change Date	Approved By
A.0	New issue	----	July,24,2018	Jinhua

SPECIFICATION

DESC	Φ 13.5x39-6.5uH-0.08x105P-20mm-43.5C	Rev: A.0	CUST:	XXX
			CUST P/N:	

一、DIMENSION:(mm)

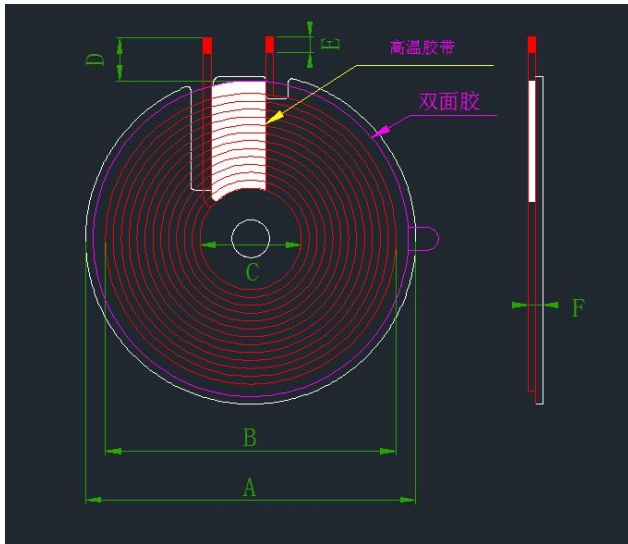

A	43.5.0±0.5
B	39±1
C	13.5±0.5
D	20±2
E	3±2
F	2±0.2

Notes:

1. Cross out the wire.
2. Wrap 8mm (ref) width high temperature adhesive paper 1-2Ts at the wire outlet position.
3. Coil paste round hard magnetic sheet with groove, magnetic sheet size 43.5±0.5mm, inner hole 5.3mm, thickness 0.8±0.2mm, adhesive backing.

For phone: 113kHz-205kHz

Antenna gain: 0dBi

二、SCHEMATIC DIAGRAM:

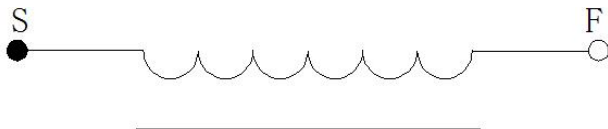

三、Winding Specification:

NO.	TERMINAL	WIRE	Turns	Winding Direction
1	S F	silk-covered wire 0.08*105P	12Ts	CCW

四、ELECTRICAL CHARACTERISTICS:

TEMPERATURE:25±10°C, RELATIVE HUMIDITY:65±20%

NO.	ITEM	TERMINAL	SPECIFICATION	TEST FREQUENCY	TEST EQUIPMENTS
1	IND.	S-F	3.8uH ±20% single coil	100KHz/1.0V	LCZ METER 1062B
2	IND.	S-F	6.5uH ±10% +	100KHz/1.0V	LCZ METER 1062B
3	Q	S-F	≥55		
4	DCR	S-F	≤48mΩ		LCZ METER 502B

PREPARED BY/DATE	CHECKED BY/DATE
------------------	-----------------

Yanming Huang November 1, 2022	Jinhua Huang November 1,2022
--------------------------------	------------------------------