FCC Test Report

Report No.: AGC14499230609FE06

FCC ID : 2APPZ-AP6221
APPLICATION PURPOSE : Original Equipment
PRODUCT DESIGNATION : IP Phone
BRAND NAME : **Fanvil**
MODEL NAME : X305
APPLICANT : Fanvil Technology Co., Ltd.
DATE OF ISSUE : Jul. 19, 2023
STANDARD(S) : FCC Part 15 Subpart E §15.407
REPORT VERSION : V1.0

Attestation of Global Compliance (Shenzhen) Co., Ltd



Any report having not been signed by authorized approver, or having been altered without authorization, or having not been stamped by the "Dedicated Testing/Inspection Stamp" is deemed to be invalid. Copying or excerpting portion of, or altering the content of the report is not permitted without the written authorization of AGC. The test results presented in the report apply only to the tested sample. Any objections to report issued by AGC should be submitted to AGC within 15days after the issuance of the test report. Further enquiry of validity or verification of the test report should be addressed to AGC by agc01@agccert.com.

Attestation of Global Compliance(Shenzhen)Co., Ltd
Attestation of Global Compliance(Shenzhen)Std & Tech Co., Ltd
Tel: +86-755 2523 4088 E-mail: agc@agccert.com Web: <http://www.agccert.com/>



REPORT REVISE RECORD

Report Version	Revise Time	Issued Date	Valid Version	Notes
V1.0	/	Jul. 19, 2023	Valid	Initial Release

Any report having not been signed by authorized approver, or having been altered without authorization, or having not been stamped by the "Dedicated Testing/Inspection Stamp" is deemed to be invalid. Copying or excerpting portion of, or altering the content of the report is not permitted without the written authorization of AGC. The test results presented in the report apply only to the tested sample. Any objections to report issued by AGC should be submitted to AGC within 15days after the issuance of the test report. Further enquiry of validity or verification of the test report should be addressed to AGC by agc01@agccert.com.

TABLE OF CONTENTS

1. VERIFICATION OF CONFORMITY..... 5

2. GENERAL INFORMATION 6

 2.1. PRODUCT DESCRIPTION..... 6

 2.2. TABLE OF CARRIER FREQUENCIES..... 7

 2.3. RELATED SUBMITTAL(S) / GRANT (S) 10

 2.4. TEST METHODOLOGY..... 10

 2.5. SPECIAL ACCESSORIES 10

 2.6. EQUIPMENT MODIFICATIONS 10

3. TEST ENVIRONMENT 11

 3.1 ADDRESS OF THE TEST LABORATORY 11

 3.2 TEST FACILITY..... 11

 3.3 ENVIRONMENTAL CONDITIONS..... 12

 3.4 MEASUREMENT UNCERTAINTY..... 12

 3.5 LIST OF EQUIPMENTS USED..... 13

4. DESCRIPTION OF TEST MODES 14

5. SYSTEM TEST CONFIGURATION 15

 5.1. CONFIGURATION OF EUT SYSTEM..... 15

 5.2. EQUIPMENT USED IN EUT SYSTEM..... 15

 5.3. SUMMARY OF TEST RESULTS 15

6. RF OUTPUT POWER MEASUREMENT..... 16

 6.1 MEASUREMENT LIMITS 16

 6.2 MEASUREMENT PROCEDURE 16

 6.3 MEASUREMENT SETUP (BLOCK DIAGRAM OF CONFIGURATION)..... 17

 6.4 MEASUREMENT RESULT 17

7. 6DB&26DB BANDWIDTH MEASUREMENT 21

 7.1 MEASUREMENT LIMITS 21

 7.2 MEASUREMENT PROCEDURE 21

 7.3 MEASUREMENT SETUP (BLOCK DIAGRAM OF CONFIGURATION)..... 21

 7.4 MEASUREMENT RESULTS..... 22

8. POWER SPECTRAL DENSITY MEASUREMENT 63

 8.1 MEASUREMENT LIMITS 63

 8.2 MEASUREMENT PROCEDURE 63

 8.3 MEASUREMENT SETUP (BLOCK DIAGRAM OF CONFIGURATION)..... 63

 8.4 MEASUREMENT RESULT 64

9. CONDUCTED SPURIOUS EMISSION..... 98

 9.1 MEASUREMENT LIMIT 98

Any report having not been signed by authorized approver, or having been altered without authorization, or having not been stamped by the “Dedicated Testing/Inspection Stamp” is deemed to be invalid. Copying or excerpting portion of, or altering the content of the report is not permitted without the written authorization of AGC. The test results presented in the report apply only to the tested sample. Any objections to report issued by AGC should be submitted to AGC within 15days after the issuance of the test report. Further enquiry of validity or verification of the test report should be addressed to AGC by agc01@agccert.com.

9.2 MEASUREMENT PROCEDURE	98
9.3 MEASUREMENT SETUP (BLOCK DIAGRAM OF CONFIGURATION)	98
9.4 MEASUREMENT RESULTS.....	99
10. RADIATED EMISSION	156
10.1 LIMITS OF RADIATED EMISSION TEST	156
10.2 MEASUREMENT PROCEDURE	157
10.3 MEASUREMENT SETUP (BLOCK DIAGRAM OF CONFIGURATION).....	159
10.4 MEASUREMENT RESULT	160
11. AC POWER LINE CONDUCTED EMISSION TEST	219
11.1. LIMITS OF LINE CONDUCTED EMISSION TEST	219
11.2. BLOCK DIAGRAM OF LINE CONDUCTED EMISSION TEST.....	219
11.3. PRELIMINARY PROCEDURE OF LINE CONDUCTED EMISSION TEST	220
11.4. FINAL PROCEDURE OF LINE CONDUCTED EMISSION TEST.....	220
11.5. TEST RESULT OF LINE CONDUCTED EMISSION TEST	220
APPENDIX I: PHOTOGRAPHS OF TEST SETUP	225
APPENDIX II: PHOTOGRAPHS OF EUT	225



Any report having not been signed by authorized approver, or having been altered without authorization, or having not been stamped by the “Dedicated Testing/Inspection Stamp” is deemed to be invalid. Copying or excerpting portion of, or altering the content of the report is not permitted without the written authorization of AGC. The test results presented in the report apply only to the tested sample. Any objections to report issued by AGC should be submitted to AGC within 15days after the issuance of the test report. Further enquiry of validity or verification of the test report should be addressed to AGC by agc01@agccert.com.

1. VERIFICATION OF CONFORMITY

Applicant	Fanvil Technology Co., Ltd.
Address	10/F Block A, Dualshine Global Science Innovation, Honglang North 2nd Road, Bao'an District, Shenzhen, China
Manufacturer	Fanvil Technology Co., Ltd.
Address	10/F Block A, Dualshine Global Science Innovation, Honglang North 2nd Road, Bao'an District, Shenzhen, China
Factory	Fanvil Technology Co., Ltd.
Address	10/F Block A, Dualshine Global Science Innovation, Honglang North 2nd Road, Bao'an District, Shenzhen, China
Product Designation	IP Phone
Brand Name	
Test Model	X305
Date of receipt of test item	Jun. 30, 2023
Date of test	Jun. 30, 2023~Jul. 19, 2023
Deviation	No any deviation from the test method
Condition of Test Sample	Normal
Test Result	Pass
Report Template	AGCRT-US-BGN/RF

We hereby certify that:

The above equipment was tested by Attestation of Global Compliance (Shenzhen) Co., Ltd. The test data, data evaluation, test procedures, and equipment configurations shown in this report were made in accordance with the procedures given in ANSI C63.10 (2013) and the energy emitted by the sample EUT tested as described in this report is in compliance with requirement of FCC Part 15 Rules requirement.

Prepared By		
	Bibo Zhang (Project Engineer)	Jul. 19, 2023
Reviewed By		
	Calvin Liu (Reviewer)	Jul. 19, 2023
Approved By		
	Max Zhang Authorized Officer	Jul. 19, 2023

Any report having not been signed by authorized approver, or having been altered without authorization, or having not been stamped by the "Dedicated Testing/Inspection Stamp" is deemed to be invalid. Copying or excerpting portion of, or altering the content of the report is not permitted without the written authorization of AGC. The test results presented in the report apply only to the tested sample. Any objections to report issued by AGC should be submitted to AGC within 15days after the issuance of the test report. Further enquiry of validity or verification of the test report should be addressed to AGC by agc01@agccert.com.

2. GENERAL INFORMATION

2.1. PRODUCT DESCRIPTION

Equipment Type	<input type="checkbox"/> Outdoor access points <input type="checkbox"/> Indoor access points <input type="checkbox"/> Fixed P2P access points <input checked="" type="checkbox"/> Client devices
Operation Frequency	<input checked="" type="checkbox"/> U-NII 1:5150MHz~5250MHz <input checked="" type="checkbox"/> U-NII 2A: 5250MHz~5350MHz <input checked="" type="checkbox"/> U-NII 2C:5470MHz~5725MHz <input checked="" type="checkbox"/> U-NII 3: 5725MHz~5850MHz
DFS Design Type	<input type="checkbox"/> Master <input type="checkbox"/> Slave with radar detection <input checked="" type="checkbox"/> Slave without radar detection
TPC Function	<input type="checkbox"/> Yes <input checked="" type="checkbox"/> No
Hardware Version	V1.0
Software Version	T2.12.0.11
Test Frequency Range	For 802.11a/n-HT20/ac-VHT20: 5180~5240MHz, 5260~5320MHz, 5500~5700MHz, 5745~5825MHz For 802.11n-HT40/ac-VHT40: 5190~5230MHz, 5270~5310MHz, 5510~5670MHz, 5755~5795MHz For 802.11ac-VHT80: 5210MHz, 5290MHz, 5530~5610MHz, 5775MHz
Output Power	IEEE 802.11a(HT20): 11.33dBm; IEEE 802.11n(HT20): 10.54dBm; IEEE802.11n(HT40): 10.78dBm; IEEE 802.11ac(VHT20): 10.97dBm; IEEE802.11ac(VHT40): 10.98dBm; IEEE802.11ac(VHT80):10.51dBm;
Modulation	802.11a/n:(64-QAM, 16-QAM, QPSK, BPSK) OFDM 802.11ac :(256-QAM, 64-QAM, 16-QAM, QPSK, BPSK) OFDM
Data Rate	802.11a:6/9/12/18/24/36/48/54Mbps; 802.11n:up to 300Mbps; 802.11ac:up to 866.6Mbps;
Number of channels	7 channels of U-NII-1 Band 7 channels of U- NII-2A Band 18 channels of U-NII-2C Band 8 channels of U- NII 3 Band
Antenna Designation	PIFA Antenna
Antenna Gain	U-NII-1 Band: 4.0dBi U- NII-2A Band: 3.9dBi U-NII-2C Band: 4.9dBi U- NII 3 Band: 4.9dBi
Power Supply	DC 5V by adapter or DC 48V by PoE

Any report having not been signed by authorized approver, or having been altered without authorization, or having not been stamped by the "Dedicated Testing/Inspection Stamp" is deemed to be invalid. Copying or excerpting portion of, or altering the content of the report is not permitted without the written authorization of AGC. The test results presented in the report apply only to the tested sample. Any objections to report issued by AGC should be submitted to AGC within 15days after the issuance of the test report. Further enquiry of validity or verification of the test report should be addressed to AGC by agc01@agccert.com.

2.2. TABLE OF CARRIER FREQUENCIES

For 5180~5240MHz:

4 channels are provided for 802.11a, 802.11n (HT20), 802.11ac (VHT20):

Channel	Frequency	Channel	Frequency
36	5180 MHz	44	5220 MHz
40	5200 MHz	48	5240 MHz

2 channels are provided for 802.11n (HT40), 802.11ac (VHT40):

Channel	Frequency	Channel	Frequency
38	5190 MHz	46	5230 MHz

1 channel is provided for 802.11ac (VHT80):

Channel	Frequency	Channel	Frequency
42	5210 MHz	--	--

For 5260~5320MHz:

5 channels are provided for 802.11a, 802.11n (HT20), 802.11ac (VHT20):

Channel	Frequency	Channel	Frequency
52	5260 MHz	60	5300 MHz
56	5280 MHz	64	5320 MHz

2 channels are provided for 802.11n (HT40), 802.11ac (VHT40):

Channel	Frequency	Channel	Frequency
54	5270 MHz	62	5310 MHz

1 channel is provided for 802.11ac (VHT80):

Channel	Frequency	Channel	Frequency
58	5290 MHz	--	--

Any report having not been signed by authorized approver, or having been altered without authorization, or having not been stamped by the "Dedicated Testing/Inspection Stamp" is deemed to be invalid. Copying or excerpting portion of, or altering the content of the report is not permitted without the written authorization of AGC. The test results presented in the report apply only to the tested sample. Any objections to report issued by AGC should be submitted to AGC within 15days after the issuance of the test report. Further enquiry of validity or verification of the test report should be addressed to AGC by agc01@agccert.com.

For 5500~5700MHz:

11 channels are provided for 802.11a, 802.11n (HT20), 802.11ac (VHT20):

Channel	Frequency	Channel	Frequency
100	5500 MHz	124	5620 MHz
104	5520 MHz	128	5640 MHz
108	5540 MHz	132	5660 MHz
112	5560 MHz	136	5680 MHz
116	5580 MHz	140	5700 MHz
120	5600 MHz	--	--

5 channels are provided for 802.11n (HT40), 802.11ac (VHT40):

Channel	Frequency	Channel	Frequency
102	5510 MHz	126	5630 MHz
110	5550 MHz	134	5670 MHz
118	5590 MHz	--	--

2 channels are provided for 802.11ac (VHT80):

Channel	Frequency	Channel	Frequency
106	5530 MHz	122	5610 MHz

Any report having not been signed by authorized approver, or having been altered without authorization, or having not been stamped by the "Dedicated Testing/Inspection Stamp" is deemed to be invalid. Copying or excerpting portion of, or altering the content of the report is not permitted without the written authorization of AGC. The test results presented in the report apply only to the tested sample. Any objections to report issued by AGC should be submitted to AGC within 15days after the issuance of the test report. Further enquiry of validity or verification of the test report should be addressed to AGC by agc01@agccert.com.

For 5745~5825MHz:

5 channels are provided for 802.11a, 802.11n (HT20), 802.11ac (VHT20):

Channel	Frequency	Channel	Frequency
149	5745 MHz	161	5805 MHz
153	5765 MHz	165	5825 MHz
157	5785 MHz	--	--

2 channels are provided for 802.11n (HT40), 802.11ac (VHT40):

Channel	Frequency	Channel	Frequency
151	5755 MHz	159	5795 MHz

1 channel is provided for 802.11ac (VHT80):

Channel	Frequency	Channel	Frequency
155	5775 MHz	--	--

Any report having not been signed by authorized approver, or having been altered without authorization, or having not been stamped by the "Dedicated Testing/Inspection Stamp" is deemed to be invalid. Copying or excerpting portion of, or altering the content of the report is not permitted without the written authorization of AGC. The test results presented in the report apply only to the tested sample. Any objections to report issued by AGC should be submitted to AGC within 15days after the issuance of the test report. Further enquiry of validity or verification of the test report should be addressed to AGC by agc01@agccert.com.

2.3. RELATED SUBMITTAL(S) / GRANT (S)

This submittal(s) (test report) is intended for **FCC ID: 2APPZ-AP6221** filing to comply with the FCC Part 15 requirements.

2.4. TEST METHODOLOGY

No.	Identity	Document Title
1	FCC 47 CFR Part 2	Frequency allocations and radio treaty matters; general rules and regulations
2	FCC 47 CFR Part 15	Radio Frequency Devices
3	ANSI C63.10-2013	American National Standard for Testing Unlicensed Wireless Devices
5	KDB 789033	789033 D02 General U-NII Test Procedures New Rules v02r01

2.5. SPECIAL ACCESSORIES

Refer to section 5.2.

2.6. EQUIPMENT MODIFICATIONS

Not available for this EUT intended for grant.

Any report having not been signed by authorized approver, or having been altered without authorization, or having not been stamped by the "Dedicated Testing/Inspection Stamp" is deemed to be invalid. Copying or excerpting portion of, or altering the content of the report is not permitted without the written authorization of AGC. The test results presented in the report apply only to the tested sample. Any objections to report issued by AGC should be submitted to AGC within 15days after the issuance of the test report. Further enquiry of validity or verification of the test report should be addressed to AGC by agc01@agccert.com.

3. TEST ENVIRONMENT

3.1 ADDRESS OF THE TEST LABORATORY

Laboratory: Attestation of Global Compliance (Shenzhen) Co., Ltd.

Address: 1-2/F, Building 19, Junfeng Industrial Park, Chongqing Road, Heping Community, Fuhai Street, Bao'an District, Shenzhen, Guangdong, China

3.2 TEST FACILITY

The test facility is recognized, certified, or accredited by the following organizations:

CNAS-Lab Code: L5488

Attestation of Global Compliance (Shenzhen) Co., Ltd. has been assessed and proved to be in compliance with CNAS-CL01 Accreditation Criteria for Testing and Calibration Laboratories (identical to ISO/IEC17025: 2017 General Requirements) for the Competence of Testing and Calibration Laboratories.

A2LA-Lab Cert. No.: 5054.02

Attestation of Global Compliance (Shenzhen) Co., Ltd. EMC Laboratory has been accredited by A2LA for technical competence in the field of electrical testing, and proved to be in compliance with ISO/IEC 17025: 2017 General Requirements for the Competence of Testing and Calibration Laboratories and any additional program requirements in the identified field of testing.

FCC-Registration No.: 975832

Attestation of Global Compliance (Shenzhen) Co., Ltd. EMC Laboratory has been registered and fully described in a report filed with the FCC (Federal Communications Commission). The acceptance letter from the FCC is maintained in our files with Registration 975832.

IC-Registration No.: 24842 (CAB identifier: CN0063)

Attestation of Global Compliance (Shenzhen) Co., Ltd. EMC Laboratory has been registered and fully described in a report filed with the Certification and Engineering Bureau of Industry Canada. The acceptance letter from the IC is maintained in our files with Registration 24842.

Any report having not been signed by authorized approver, or having been altered without authorization, or having not been stamped by the "Dedicated Testing/Inspection Stamp" is deemed to be invalid. Copying or excerpting portion of, or altering the content of the report is not permitted without the written authorization of AGC. The test results presented in the report apply only to the tested sample. Any objections to report issued by AGC should be submitted to AGC within 15days after the issuance of the test report. Further enquiry of validity or verification of the test report should be addressed to AGC by agc01@agccert.com.

3.3 ENVIRONMENTAL CONDITIONS

	NORMAL CONDITIONS	EXTREME CONDITIONS
Temperature range (°C)	15 - 35	-30 - 50
Relative humidity range	20 % - 75 %	20 % - 75 %
Pressure range (kPa)	86 - 106	86 - 106
Power supply	DC 5.0V	LV DC 4.25V/HV DC 5.75V
Note: The Extreme Temperature and Extreme Voltages declared by the manufacturer.		

3.4 MEASUREMENT UNCERTAINTY

The reported uncertainty of measurement $y \pm U$, where expanded uncertainty U is based on a standard uncertainty multiplied by a coverage factor of $k=2$, providing a level of confidence of approximately 95%.

Item	Measurement Uncertainty
Uncertainty of Conducted Emission for AC Port	$U_c = \pm 3.1$ dB
Uncertainty of Radiated Emission below 1GHz	$U_c = \pm 4.0$ dB
Uncertainty of Radiated Emission above 1GHz	$U_c = \pm 4.8$ dB
Uncertainty of total RF power, conducted	$U_c = \pm 0.8$ dB
Uncertainty of RF power density, conducted	$U_c = \pm 2.6$ dB
Uncertainty of spurious emissions, conducted	$U_c = \pm 2$ %
Uncertainty of Occupied Channel Bandwidth	$U_c = \pm 2.7$ %

Any report having not been signed by authorized approver, or having been altered without authorization, or having not been stamped by the "Dedicated Testing/Inspection Stamp" is deemed to be invalid. Copying or excerpting portion of, or altering the content of the report is not permitted without the written authorization of AGC. The test results presented in the report apply only to the tested sample. Any objections to report issued by AGC should be submitted to AGC within 15days after the issuance of the test report. Further enquiry of validity or verification of the test report should be addressed to AGC by agc01@agccert.com.

3.5 LIST OF EQUIPMENTS USED

TEST EQUIPMENT OF CONDUCTED EMISSION TEST

Equipment	Manufacturer	Model	S/N	Cal. Date	Cal. Due
TEST RECEIVER	R&S	ESPI	101206	Jun. 03, 2023	Jun. 02, 2024
LISN	R&S	ESH2-Z5	100086	Jun. 03, 2023	Jun. 02, 2024
Test software	R&S	ES-K1 (Ver.V1.71)	N/A	N/A	N/A

TEST EQUIPMENT OF RADIATED EMISSION TEST

Equipment	Manufacturer	Model	S/N	Cal. Date	Cal. Due
TEST RECEIVER	R&S	ESCI	10096	Feb. 18, 2023	Feb. 17, 2024
EXA Signal Analyzer	Aglient	N9010A	MY53470504	Aug. 04, 2022	Aug. 03, 2023
Power sensor	Aglient	U2021XA	MY54110007	Jun. 01, 2023	May 31, 2024
5GHz Fliter	EM Electronics	5150-5880MHz	N/A	N/A	N/A
USB Wideband Power Sensor	Agilent	U2021XA	MY54110007	Mar. 03, 2023	Mar. 02, 2024
Attenuator	ZHINAN	E-002	N/A	Sep. 01, 2022	Aug. 31, 2023
Horn antenna	SCHWARZBECK	BBHA 9170	#768	Oct. 31, 2021	Oct. 30, 2023
Active loop antenna (9K-30MHz)	ZHINAN	ZN30900C	18051	Mar. 12, 2022	Mar. 11, 2024
Double-Ridged Waveguide Horn	ETS LINDGREN	3117	00034609	Mar. 23, 2023	Mar. 22, 2024
Broadband Preamplifier	ETS LINDGREN	3117PA	00225134	N/A	N/A
ANTENNA	SCHWARZBECK	VULB9168	494	Jan. 05, 2023	Jan. 04, 2025
Test software	Tonscend	JS32-RE (Ver.2.5)	N/A	N/A	N/A

Any report having not been signed by authorized approver, or having been altered without authorization, or having not been stamped by the "Dedicated Testing/Inspection Stamp" is deemed to be invalid. Copying or excerpting portion of, or altering the content of the report is not permitted without the written authorization of AGC. The test results presented in the report apply only to the tested sample. Any objections to report issued by AGC should be submitted to AGC within 15days after the issuance of the test report. Further enquiry of validity or verification of the test report should be addressed to AGC by agc01@agccert.com.

4. DESCRIPTION OF TEST MODES

Mode	Available channel	Tested channel	Modulation	Date rate (Mbps)
802.11a/n/ac	Refer to Section 2.2	36,40,48,52,60,64,100 116,140,149,157,165	OFDM	6Mbps/MCS0
802.11n/ac		38,46,54,62,102 110,134,151,159	OFDM	MCS0
802.11ac		42,58,106,121,155	OFDM	MCS0

Note:

1. The EUT has been set to operate continuously on tested channel individually, and the EUT is operating at its maximum duty cycle>or equal 98%.
2. All modes under which configure applicable have been tested and the worst mode test data recording in the test report, if no other mode data.

Software Setting

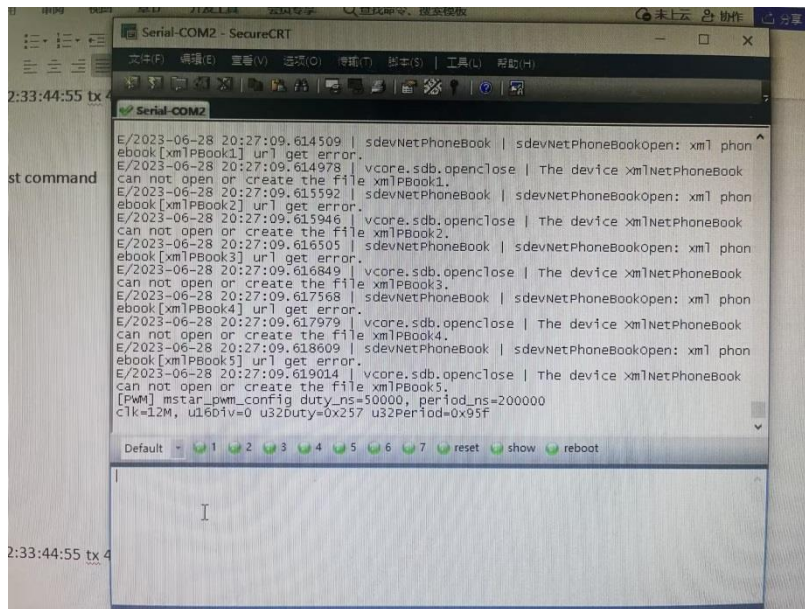

Any report having not been signed by authorized approver, or having been altered without authorization, or having not been stamped by the “Dedicated Testing/Inspection Stamp” is deemed to be invalid. Copying or excerpting portion of, or altering the content of the report is not permitted without the written authorization of AGC. The test results presented in the report apply only to the tested sample. Any objections to report issued by AGC should be submitted to AGC within 15days after the issuance of the test report. Further enquiry of validity or verification of the test report should be addressed to AGC by agc01@agccert.com.

5. SYSTEM TEST CONFIGURATION

5.1. CONFIGURATION OF EUT SYSTEM

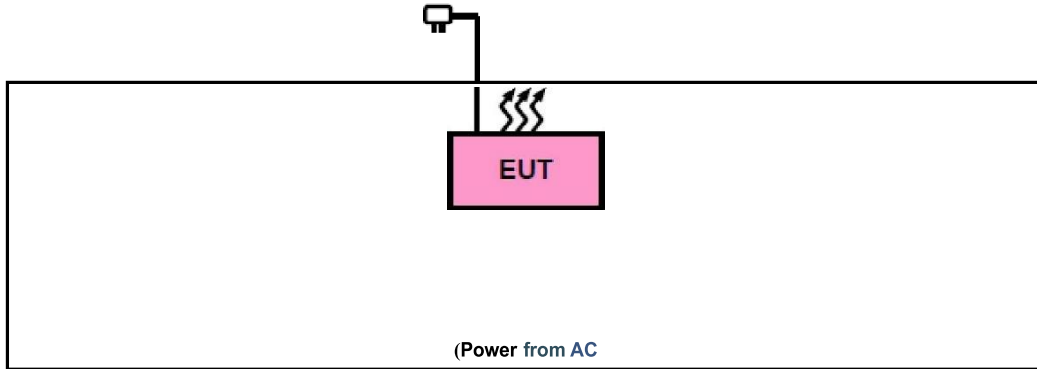

5.2. EQUIPMENT USED IN EUT SYSTEM

Item	Equipment	Model No.	ID or Specification	Remark
1	IP Phone	X305	FCC ID: 2APPZ-AP6221	EUT
2	Adapter	GQ12-050200-AU	Input: AC 100-240V 50/60Hz, 0.4A Output: DC 5.0V 2A	AE
3	Ethernet Cable	N/A	N/A	AE
4	Handset Wire	N/A	1.5m Unshielded	AE
5	Handset	N/A	N/A	AE
6	Wall Stand	N/A	N/A	AE
7	Stand	N/A	N/A	AE
8	PoE	ADS-120HK-48-1 520120E	DC 12V 1A (IEEE 802.3af)	AE

5.3. SUMMARY OF TEST RESULTS

Item	FCC Rules	Description Of Test	Result
1	§15.203	Antenna Equipment	Pass
2	§15.407(a/1/2/3)	RF Output Power	Pass
3	§15.407(e)	6dB Bandwidth Measurement	Pass
4	§2.1049	26dB bandwidth Measurement	Pass
5	§15.407(a/1/2/3)	Power Spectral Density	Pass
6	§15.407(b)(1/2/3/4)	Conducted Spurious Emission	Pass
7	§15.209, §15.407(b)(1/2/3/4)	Radiated Emission & Band Edge	Pass
8	§15.207	AC Power Line Conducted Emission	Pass

Any report having not been signed by authorized approver, or having been altered without authorization, or having not been stamped by the "Dedicated Testing/Inspection Stamp" is deemed to be invalid. Copying or excerpting portion of, or altering the content of the report is not permitted without the written authorization of AGC. The test results presented in the report apply only to the tested sample. Any objections to report issued by AGC should be submitted to AGC within 15 days after the issuance of the test report. Further enquiry of validity or verification of the test report should be addressed to AGC by agc01@agccert.com.

6. RF OUTPUT POWER MEASUREMENT

6.1 MEASUREMENT LIMITS

Operation Band	EUT Category		LIMIT
U-NII-1	<input type="checkbox"/>	Outdoor Access Point	1 Watt (30 dBm) (Max. e.i.r.p < 125mW(21 dBm) at any elevation angle above 30 degrees as measured from the horizon)
	<input type="checkbox"/>	Fixed point-to-point Access Point	1 Watt (30 dBm)
	<input type="checkbox"/>	Indoor Access Point	1 Watt (30 dBm)
	<input checked="" type="checkbox"/>	Client devices	250mW (23.98 dBm)
U-NII-2A	/		250mW (23.98 dBm) or 11 dBm+10 log B*
U-NII-2C	/		250mW (23.98 dBm) or 11 dBm+10 log B*
U-NII-3	/		1 Watt (30 dBm)

Note: Where B is the 26dB emission bandwidth in MHz.

6.2 MEASUREMENT PROCEDURE

Method PM is Measurement using an RF average power meter. The procedure for this method is as follows:

1. The testing follows the ANSI C63.10 Section 12.3.3.1
2. Measurements may be performed using a wideband RF power meter with a thermocouple detector or equivalent if all of the following conditions are satisfied:
3. The EUT is configured to transmit continuously, or to transmit with a constant duty cycle.
4. At all times when the EUT is transmitting, it shall be transmitting at its maximum power control level.
5. The integration period of the power meter exceeds the repetition period of the transmitted signal by at least a factor of five.
6. Determine according to the duty cycle of the equipment: when it is less than 98%, follow the steps below.
7. Measure the average power of the transmitter. This measurement is an average over both the ON and OFF periods of the transmitter.
8. Adjust the measurement in dBm by adding $[10 \log (1 / D)]$, where D is the duty cycle {e.g., $[10 \log (1 / 0.25)]$, if the duty cycle is 25%}.
9. Record the test results in the report.

Any report having not been signed by authorized approver, or having been altered without authorization, or having not been stamped by the "Dedicated Testing/Inspection Stamp" is deemed to be invalid. Copying or excerpting portion of, or altering the content of the report is not permitted without the written authorization of AGC. The test results presented in the report apply only to the tested sample. Any objections to report issued by AGC should be submitted to AGC within 15days after the issuance of the test report. Further enquiry of validity or verification of the test report should be addressed to AGC by agc01@agccert.com.

6.3 MEASUREMENT SETUP (BLOCK DIAGRAM OF CONFIGURATION)

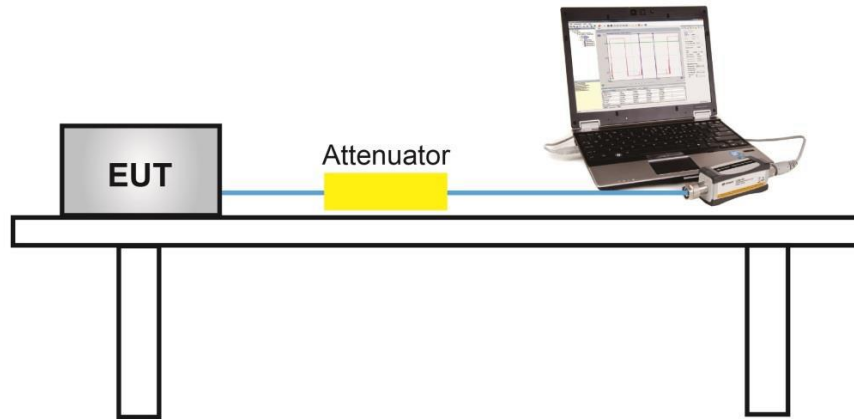

6.4 MEASUREMENT RESULT

Test Data of Conducted Output Power for band 5.15-5.25 GHz				
Test Mode	Test Channel (MHz)	Average Power (dBm)	Limits (dBm)	Pass or Fail
802.11a	5180	10.70	23.98	Pass
	5200	10.09	23.98	Pass
	5240	11.33	23.98	Pass
802.11n20	5180	9.77	23.98	Pass
	5200	10.37	23.98	Pass
	5240	10.54	23.98	Pass
802.11n40	5190	10.44	23.98	Pass
	5230	10.78	23.98	Pass
802.11ac20	5180	9.72	23.98	Pass
	5200	10.14	23.98	Pass
	5240	10.97	23.98	Pass
802.11ac40	5190	10.28	23.98	Pass
	5230	10.98	23.98	Pass
802.11ac80	5210	10.39	23.98	Pass

Any report having not been signed by authorized approver, or having been altered without authorization, or having not been stamped by the “Dedicated Testing/Inspection Stamp” is deemed to be invalid. Copying or excerpting portion of, or altering the content of the report is not permitted without the written authorization of AGC. The test results presented in the report apply only to the tested sample. Any objections to report issued by AGC should be submitted to AGC within 15days after the issuance of the test report. Further enquiry of validity or verification of the test report should be addressed to AGC by agc01@agccert.com.

Test Data of Conducted Output Power for band 5.25-5.35 GHz				
Test Mode	Test Channel (MHz)	Average Power (dBm)	Limits (dBm)	Pass or Fail
802.11a	5260	9.65	23.98	Pass
	5300	10.21	23.98	Pass
	5320	10.23	23.98	Pass
802.11n20	5260	8.62	23.98	Pass
	5300	9.29	23.98	Pass
	5320	9.40	23.98	Pass
802.11n40	5270	7.80	23.98	Pass
	5310	8.36	23.98	Pass
802.11ac20	5260	8.26	23.98	Pass
	5300	9.20	23.98	Pass
	5320	9.34	23.98	Pass
802.11ac40	5270	8.92	23.98	Pass
	5310	9.14	23.98	Pass
802.11ac80	5290	9.53	23.98	Pass

Any report having not been signed by authorized approver, or having been altered without authorization, or having not been stamped by the "Dedicated Testing/Inspection Stamp" is deemed to be invalid. Copying or excerpting portion of, or altering the content of the report is not permitted without the written authorization of AGC. The test results presented in the report apply only to the tested sample. Any objections to report issued by AGC should be submitted to AGC within 15days after the issuance of the test report. Further enquiry of validity or verification of the test report should be addressed to AGC by agc01@agccert.com.

Test Data of Conducted Output Power for band 5.470-5.725 GHz				
Test Mode	Test Channel (MHz)	Average Power (dBm)	Limits (dBm)	Pass or Fail
802.11a	5500	9.10	23.98	Pass
	5600	10.81	23.98	Pass
	5700	9.63	23.98	Pass
802.11n20	5500	8.38	23.98	Pass
	5600	10.16	23.98	Pass
	5700	9.38	23.98	Pass
802.11n40	5510	9.48	23.98	Pass
	5590	10.62	23.98	Pass
	5670	10.47	23.98	Pass
802.11ac20	5500	8.46	23.98	Pass
	5600	10.25	23.98	Pass
	5700	9.25	23.98	Pass
802.11ac40	5510	8.85	23.98	Pass
	5590	10.69	23.98	Pass
	5670	10.24	23.98	Pass
802.11ac80	5530	9.68	23.98	Pass
	5610	10.51	23.98	Pass

Any report having not been signed by authorized approver, or having been altered without authorization, or having not been stamped by the "Dedicated Testing/Inspection Stamp" is deemed to be invalid. Copying or excerpting portion of, or altering the content of the report is not permitted without the written authorization of AGC. The test results presented in the report apply only to the tested sample. Any objections to report issued by AGC should be submitted to AGC within 15days after the issuance of the test report. Further enquiry of validity or verification of the test report should be addressed to AGC by agc01@agccert.com.

Test Data of Conducted Output Power for band 5.725-5.850 GHz				
Test Mode	Test Channel (MHz)	Average Power (dBm)	Limits (dBm)	Pass or Fail
802.11a	5745	10.35	30	Pass
	5785	9.76	30	Pass
	5825	9.33	30	Pass
802.11n20	5745	9.99	30	Pass
	5785	9.40	30	Pass
	5825	8.55	30	Pass
802.11n40	5755	9.86	30	Pass
	5795	8.82	30	Pass
802.11ac20	5745	9.94	30	Pass
	5785	9.32	30	Pass
	5825	8.73	30	Pass
802.11ac40	5755	9.88	30	Pass
	5795	9.25	30	Pass
802.11ac80	5775	9.72	30	Pass

Any report having not been signed by authorized approver, or having been altered without authorization, or having not been stamped by the "Dedicated Testing/Inspection Stamp" is deemed to be invalid. Copying or excerpting portion of, or altering the content of the report is not permitted without the written authorization of AGC. The test results presented in the report apply only to the tested sample. Any objections to report issued by AGC should be submitted to AGC within 15days after the issuance of the test report. Further enquiry of validity or verification of the test report should be addressed to AGC by agc01@agccert.com.

7. 6DB&26DB BANDWIDTH MEASUREMENT

7.1 MEASUREMENT LIMITS

The minimum 6dB bandwidth shall be at least 500 kHz.

7.2 MEASUREMENT PROCEDURE

7.2.1 -6dB bandwidth (DTS bandwidth) Test setting:

1. Connect EUT RF output port to the Spectrum Analyzer through an RF attenuator
2. Set the EUT Work on operation frequency individually.
3. Set RBW = 100kHz.
4. Set the VBW $\geq 3 \times$ RBW. Detector = Peak. Trace mode = max hold.
5. Measure the maximum width of the emission that is 6 dB down from the peak of the emission.

7.2.2 99% occupied bandwidth test setting:

1. Connect EUT RF output port to the Spectrum Analyzer through an RF attenuator
2. Set the EUT Work on the top, the middle and the bottom operation frequency individually.
3. Set Span = approximately 1.5 to 5 times the OBW, centered on a nominal channel
The nominal IF filter bandwidth (3 dB RBW) shall be in the range of 1% to 5% of the OBW and video bandwidth (VBW) shall be approximately three times RBW; Sweep = auto; Detector function = peak
4. Set SPA Trace 1 Max hold, then View.

7.2.3 -26dB Bandwidth test setting:

1. Set RBW = approximately 1% of the emission bandwidth.
2. Set the VBW > RBW.
3. Detector = Peak.
4. Trace mode = max hold.
5. Measure the maximum width of the emission that is 26 dB down from the maximum of the emission.
Compare this with the RBW setting of the analyzer. Readjust RBW and repeat measurement as needed until the RBW/EBW ratio is approximately 1%.

Note: The EUT was tested according to KDB 789033 for compliance to FCC 47CFR 15.407 requirements.

7.3 MEASUREMENT SETUP (BLOCK DIAGRAM OF CONFIGURATION)

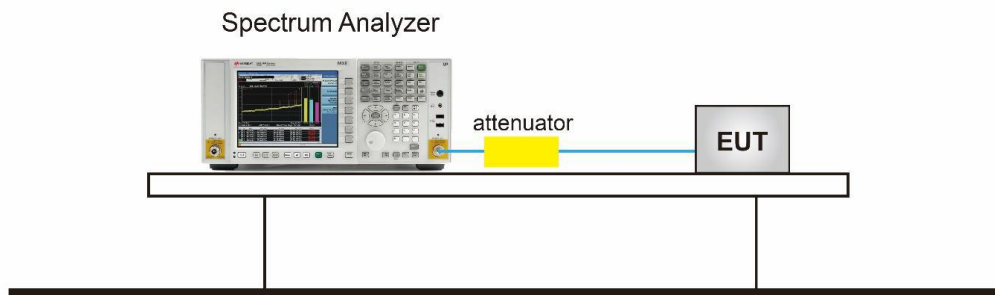

Any report having not been signed by authorized approver, or having been altered without authorization, or having not been stamped by the "Dedicated Testing/Inspection Stamp" is deemed to be invalid. Copying or excerpting portion of, or altering the content of the report is not permitted without the written authorization of AGC. The test results presented in the report apply only to the tested sample. Any objections to report issued by AGC should be submitted to AGC within 15days after the issuance of the test report. Further enquiry of validity or verification of the test report should be addressed to AGC by agc01@agccert.com.

7.4 MEASUREMENT RESULTS

Test Data of Occupied Bandwidth and -26dB Bandwidth for band 5.15-5.25 GHz					
Test Mode	Test Channel (MHz)	99% Occupied Bandwidth (MHz)	-26dB Bandwidth (MHz)	Limits (MHz)	Pass or Fail
802.11a	5180	16.657	23.229	N/A	Pass
	5200	16.661	21.626	N/A	Pass
	5240	16.885	29.197	N/A	Pass
802.11n20	5180	17.700	21.305	N/A	Pass
	5200	17.766	21.485	N/A	Pass
	5240	17.788	26.974	N/A	Pass
802.11n40	5190	36.313	43.288	N/A	Pass
	5230	36.450	55.202	N/A	Pass
802.11ac20	5180	17.721	21.187	N/A	Pass
	5200	17.760	21.129	N/A	Pass
	5240	17.862	28.750	N/A	Pass
802.11ac40	5190	36.336	48.606	N/A	Pass
	5230	36.379	50.416	N/A	Pass
802.11ac80	5210	75.869	85.632	N/A	Pass

Any report having not been signed by authorized approver, or having been altered without authorization, or having not been stamped by the "Dedicated Testing/Inspection Stamp" is deemed to be invalid. Copying or excerpting portion of, or altering the content of the report is not permitted without the written authorization of AGC. The test results presented in the report apply only to the tested sample. Any objections to report issued by AGC should be submitted to AGC within 15days after the issuance of the test report. Further enquiry of validity or verification of the test report should be addressed to AGC by agc01@agccert.com.

Test Data of Occupied Bandwidth and -26dB Bandwidth for band 5.25-5.35 GHz					
Test Mode	Test Channel (MHz)	99% Occupied Bandwidth (MHz)	-26dB Bandwidth (MHz)	Limits (MHz)	Pass or Fail
802.11a	5260	16.717	24.877	N/A	Pass
	5300	16.850	29.390	N/A	Pass
	5320	16.831	28.338	N/A	Pass
802.11n20	5260	17.752	29.283	N/A	Pass
	5300	17.810	26.118	N/A	Pass
	5320	17.835	24.188	N/A	Pass
802.11n40	5270	36.287	42.368	N/A	Pass
	5310	36.320	45.612	N/A	Pass
802.11ac20	5260	17.761	22.089	N/A	Pass
	5300	17.812	24.486	N/A	Pass
	5320	17.781	25.252	N/A	Pass
802.11ac40	5270	36.262	50.576	N/A	Pass
	5310	36.292	49.756	N/A	Pass
802.11ac80	5290	75.950	95.910	N/A	Pass

Any report having not been signed by authorized approver, or having been altered without authorization, or having not been stamped by the "Dedicated Testing/Inspection Stamp" is deemed to be invalid. Copying or excerpting portion of, or altering the content of the report is not permitted without the written authorization of AGC. The test results presented in the report apply only to the tested sample. Any objections to report issued by AGC should be submitted to AGC within 15days after the issuance of the test report. Further enquiry of validity or verification of the test report should be addressed to AGC by agc01@agccert.com.

Test Data of Occupied Bandwidth and -26dB Bandwidth for band 5.47-5.725 GHz					
Test Mode	Test Channel (MHz)	99% Occupied Bandwidth (MHz)	-26dB Bandwidth (MHz)	Limits (MHz)	Pass or Fail
802.11a	5500	16.610	20.564	N/A	Pass
	5600	16.645	21.085	N/A	Pass
	5700	16.596	20.788	N/A	Pass
802.11n20	5500	17.715	21.409	N/A	Pass
	5600	17.741	21.412	N/A	Pass
	5700	17.691	20.961	N/A	Pass
802.11n40	5510	36.287	42.288	N/A	Pass
	5590	36.266	42.117	N/A	Pass
	5670	36.268	42.323	N/A	Pass
802.11ac20	5500	17.712	21.125	N/A	Pass
	5600	17.681	21.147	N/A	Pass
	5700	17.661	20.989	N/A	Pass
802.11ac40	5510	36.255	42.786	N/A	Pass
	5590	36.314	41.997	N/A	Pass
	5670	36.272	41.809	N/A	Pass
802.11ac80	5530	75.771	82.120	N/A	Pass
	5610	75.885	82.848	N/A	Pass

Any report having not been signed by authorized approver, or having been altered without authorization, or having not been stamped by the "Dedicated Testing/Inspection Stamp" is deemed to be invalid. Copying or excerpting portion of, or altering the content of the report is not permitted without the written authorization of AGC. The test results presented in the report apply only to the tested sample. Any objections to report issued by AGC should be submitted to AGC within 15days after the issuance of the test report. Further enquiry of validity or verification of the test report should be addressed to AGC by agc01@agccert.com.

Test Data of Occupied Bandwidth and DTS Bandwidth for band 5.725-5.85 GHz					
Test Mode	Test Channel (MHz)	99% Occupied Bandwidth (MHz)	DTS Bandwidth (MHz)	Limits (MHz)	Pass or Fail
802.11a	5745	16.641	16.359	0.5	Pass
	5785	16.638	16.350	0.5	Pass
	5825	16.621	16.361	0.5	Pass
802.11n20	5745	17.758	17.561	0.5	Pass
	5785	17.707	17.289	0.5	Pass
	5825	17.824	17.560	0.5	Pass
802.11n40	5755	36.330	36.318	0.5	Pass
	5795	36.327	36.006	0.5	Pass
802.11ac20	5745	17.772	17.576	0.5	Pass
	5785	17.731	17.305	0.5	Pass
	5825	17.735	17.544	0.5	Pass
802.11ac40	5755	36.346	36.330	0.5	Pass
	5795	36.323	36.333	0.5	Pass
802.11ac80	5775	75.832	75.524	0.5	Pass

Any report having not been signed by authorized approver, or having been altered without authorization, or having not been stamped by the "Dedicated Testing/Inspection Stamp" is deemed to be invalid. Copying or excerpting portion of, or altering the content of the report is not permitted without the written authorization of AGC. The test results presented in the report apply only to the tested sample. Any objections to report issued by AGC should be submitted to AGC within 15days after the issuance of the test report. Further enquiry of validity or verification of the test report should be addressed to AGC by agc01@agccert.com.

Test Graphs of Occupied Bandwidth and -26dB Bandwidth for band 5.15-5.25 GHz

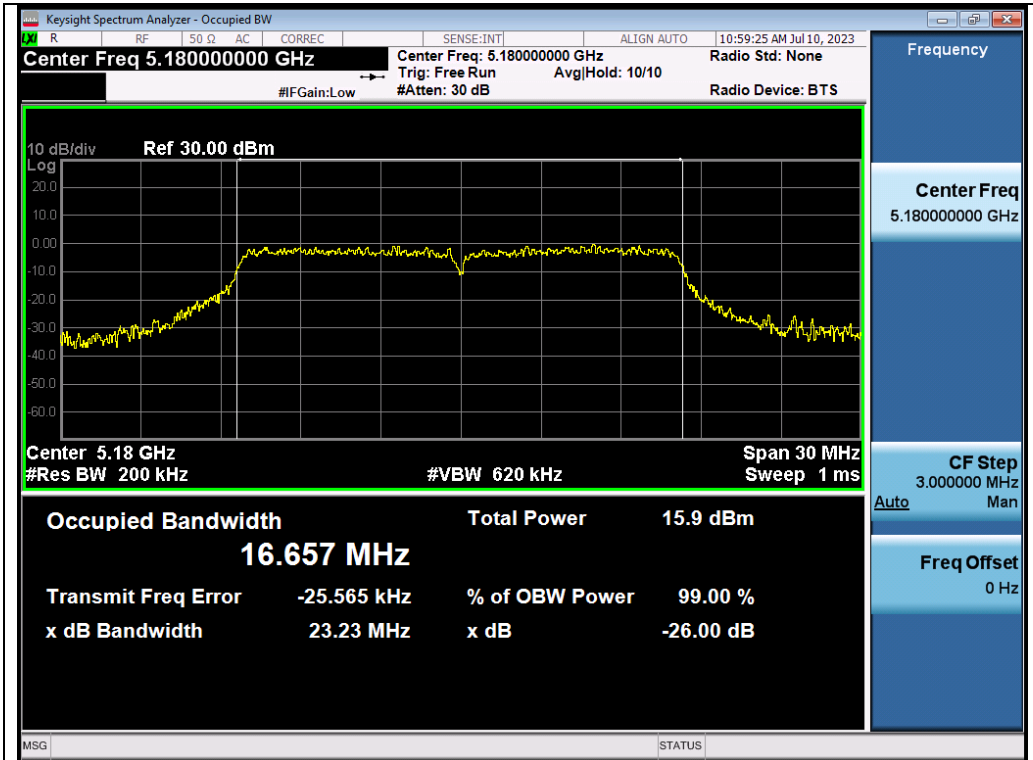

Test_Graph_802.11a_ANT1_5180_6Mbps_OBW

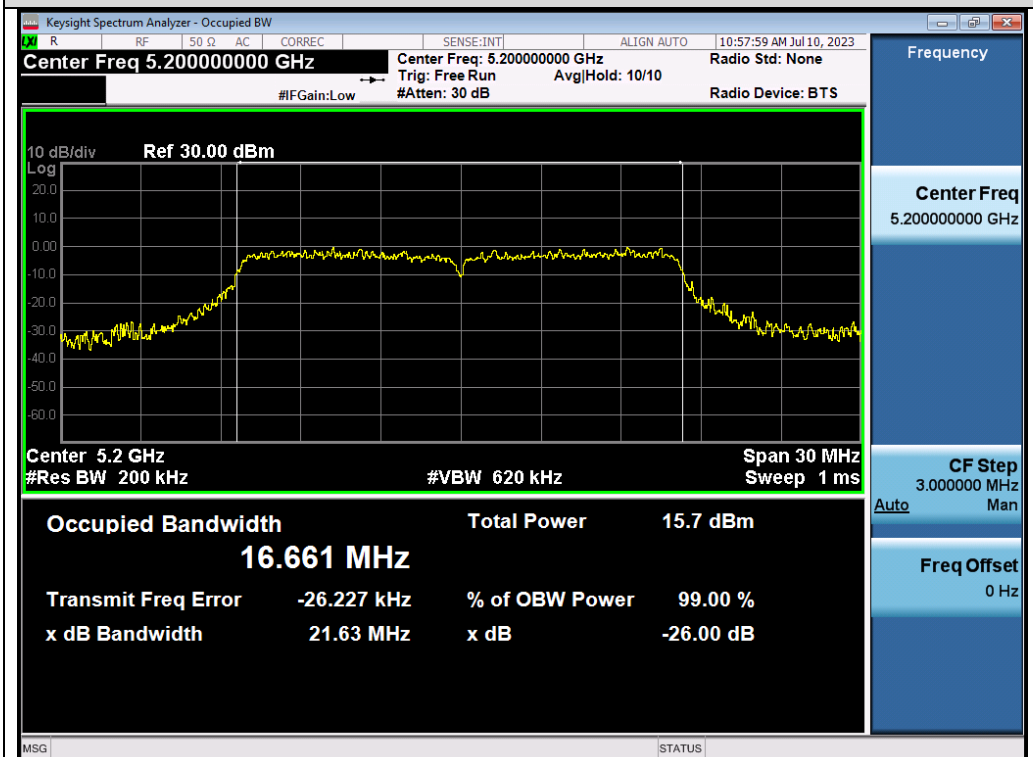

Test_Graph_802.11a_ANT1_5200_6Mbps_OBW

Any report having not been signed by authorized approver, or having been altered without authorization, or having not been stamped by the "Dedicated Testing/Inspection Stamp" is deemed to be invalid. Copying or excerpting portion of, or altering the content of the report is not permitted without the written authorization of AGC. The test results presented in the report apply only to the tested sample. Any objections to report issued by AGC should be submitted to AGC within 15days after the issuance of the test report. Further enquiry of validity or verification of the test report should be addressed to AGC by agc01@agccert.com.

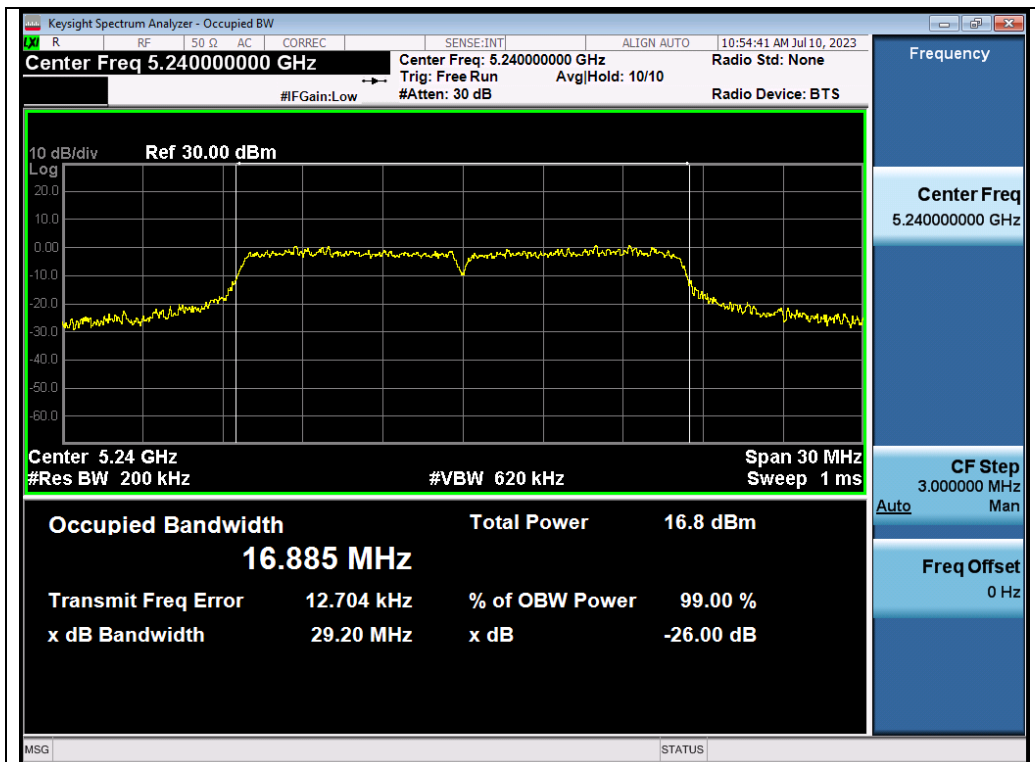

Test_Graph_802.11a_ANT1_5240_6Mbps_OBW

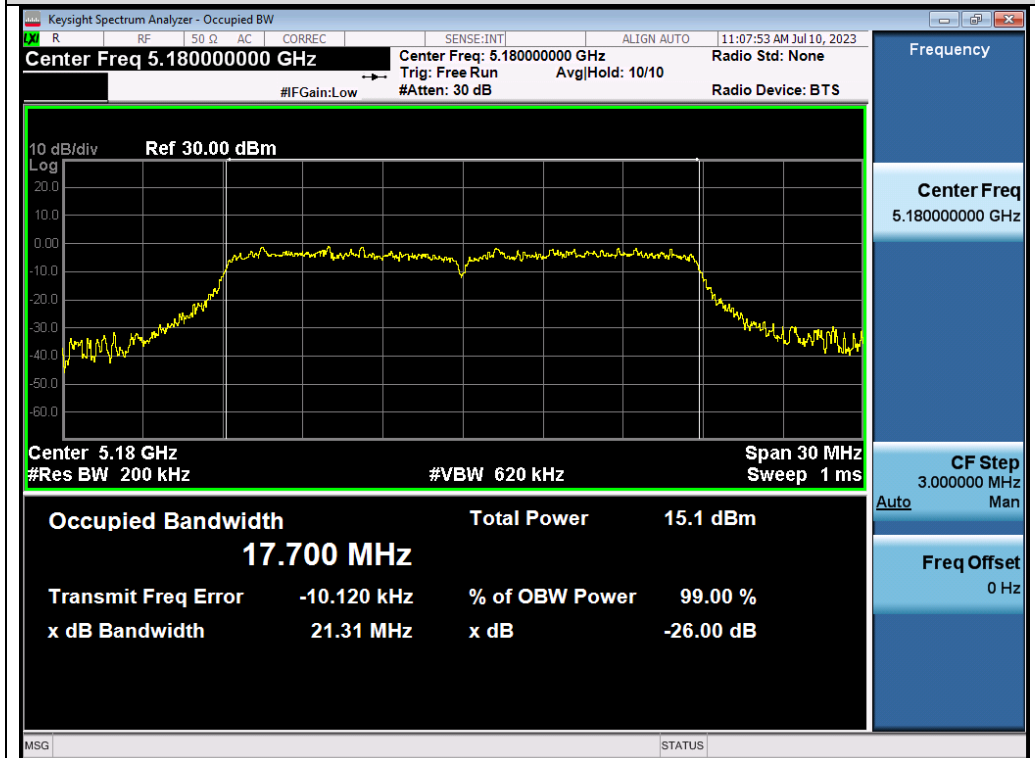

Test_Graph_802.11n20_ANT1_5180_MCS0_OBW

Any report having not been signed by authorized approver, or having been altered without authorization, or having not been stamped by the "Dedicated Testing/Inspection Stamp" is deemed to be invalid. Copying or excerpting portion of, or altering the content of the report is not permitted without the written authorization of AGC. The test results presented in the report apply only to the tested sample. Any objections to report issued by AGC should be submitted to AGC within 15days after the issuance of the test report. Further enquiry of validity or verification of the test report should be addressed to AGC by agc01@agccert.com.

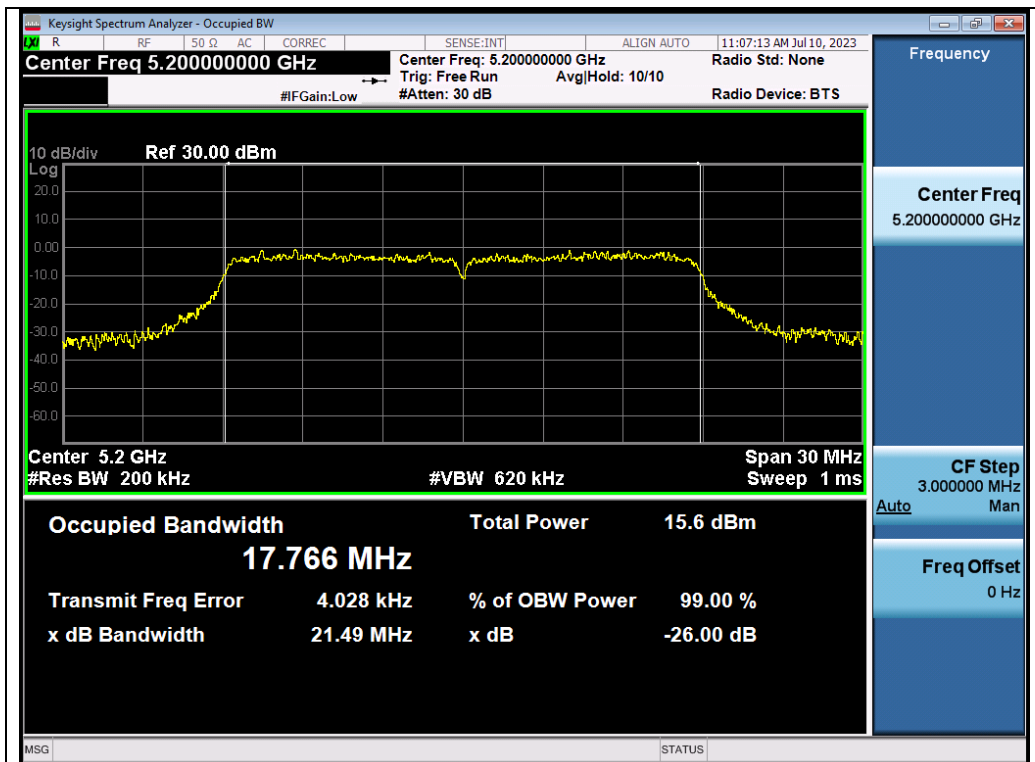

Test_Graph_802.11n20_ANT1_5200_MCS0_OBW

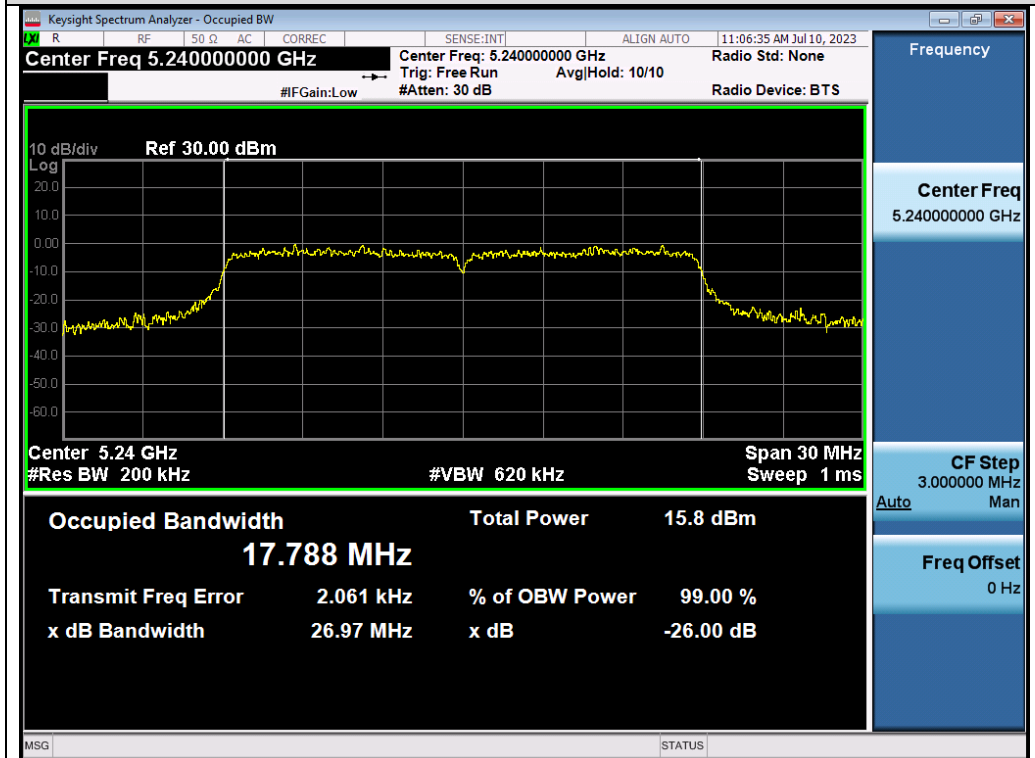

Test_Graph_802.11n20_ANT1_5240_MCS0_OBW

Any report having not been signed by authorized approver, or having been altered without authorization, or having not been stamped by the "Dedicated Testing/Inspection Stamp" is deemed to be invalid. Copying or excerpting portion of, or altering the content of the report is not permitted without the written authorization of AGC. The test results presented in the report apply only to the tested sample. Any objections to report issued by AGC should be submitted to AGC within 15days after the issuance of the test report. Further enquiry of validity or verification of the test report should be addressed to AGC by agc01@agccert.com.

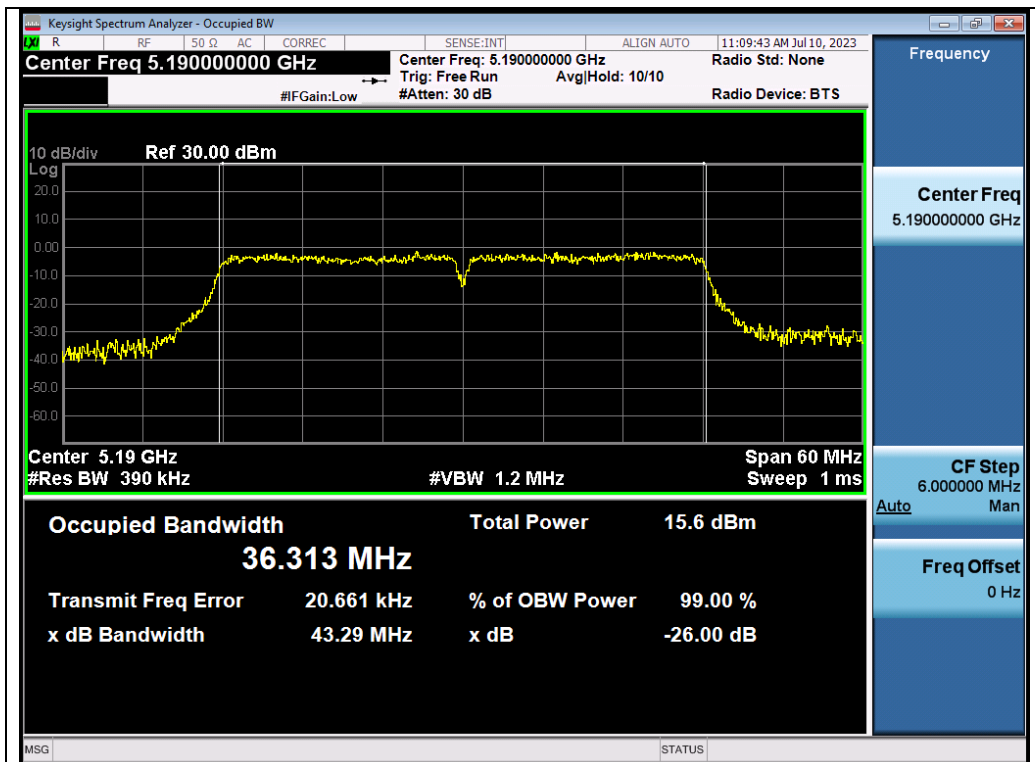

Test_Graph_802.11n40_ANT1_5190_MCS0_OBW

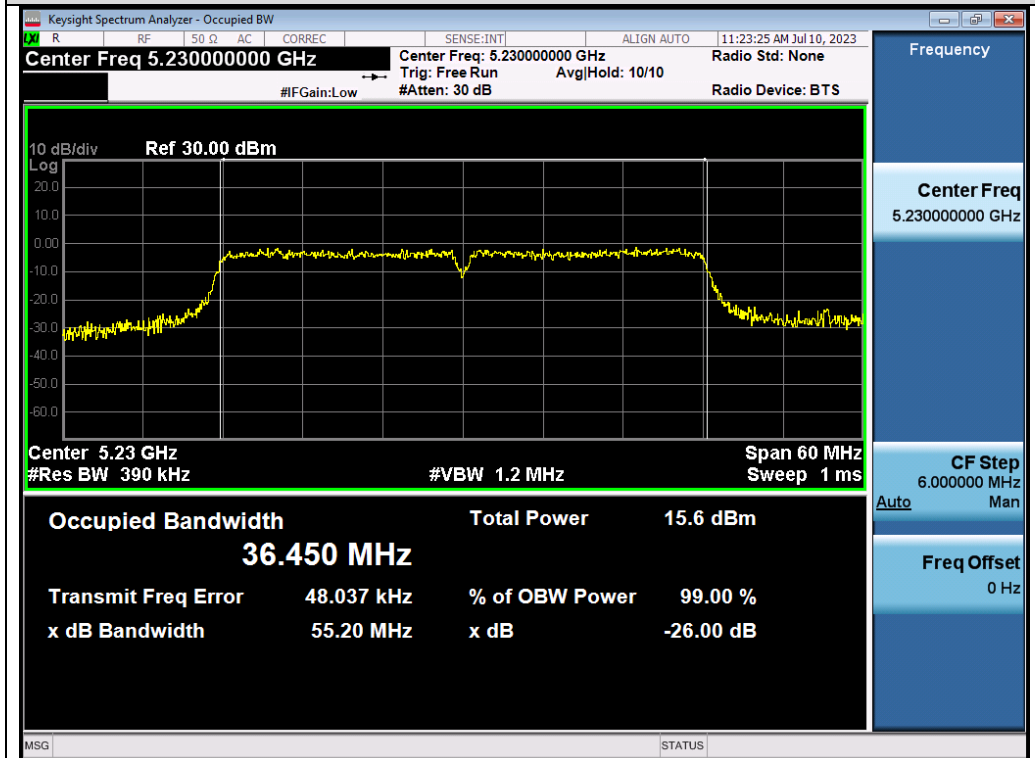

Test_Graph_802.11n40_ANT1_5230_MCS0_OBW

Any report having not been signed by authorized approver, or having been altered without authorization, or having not been stamped by the "Dedicated Testing/Inspection Stamp" is deemed to be invalid. Copying or excerpting portion of, or altering the content of the report is not permitted without the written authorization of AGC. The test results presented in the report apply only to the tested sample. Any objections to report issued by AGC should be submitted to AGC within 15days after the issuance of the test report. Further enquiry of validity or verification of the test report should be addressed to AGC by agc01@agccert.com.

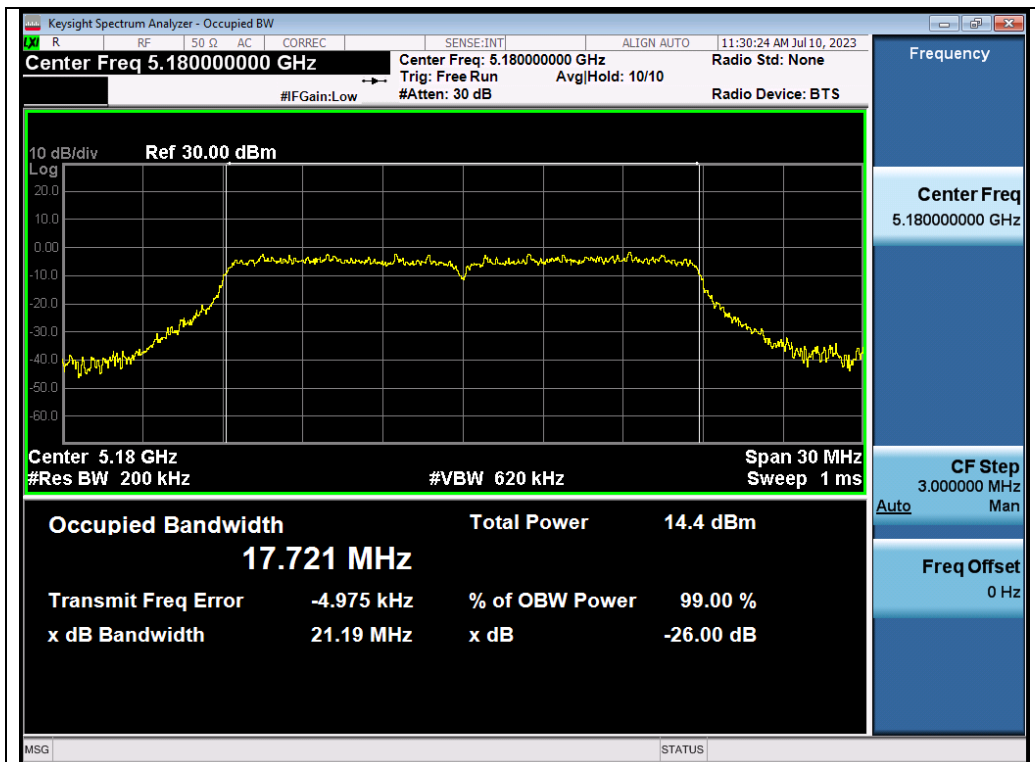

Test_Graph_802.11ac20_ANT1_5180_MCS0_OBW

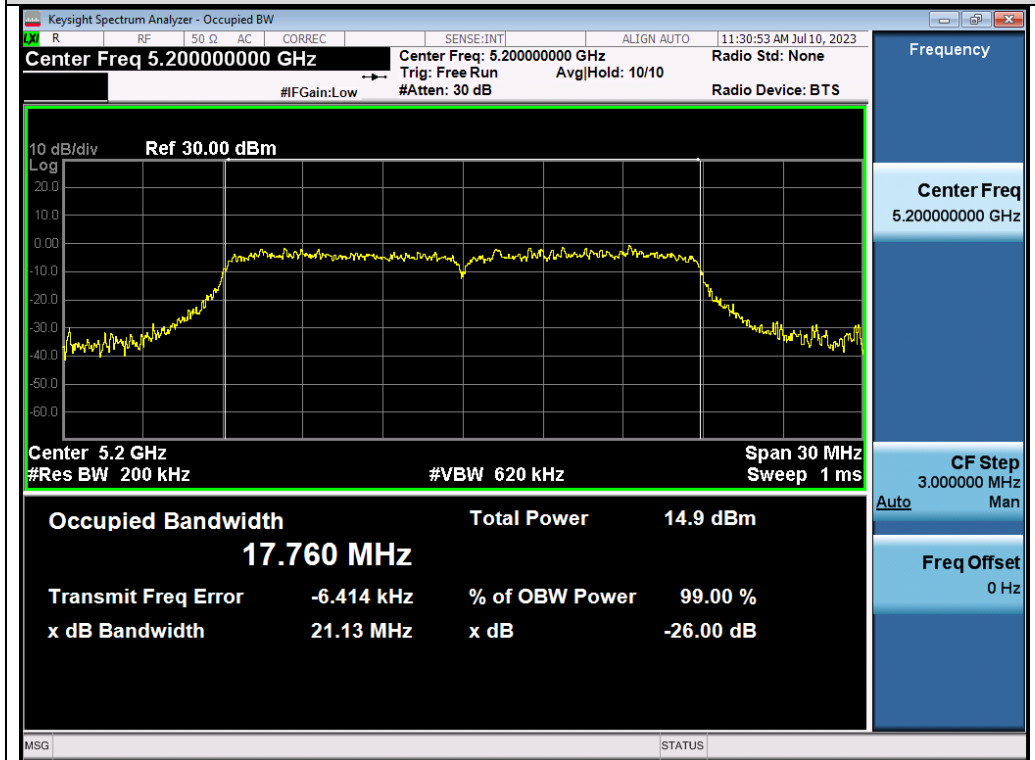

Test_Graph_802.11ac20_ANT1_5200_MCS0_OBW

Any report having not been signed by authorized approver, or having been altered without authorization, or having not been stamped by the "Dedicated Testing/Inspection Stamp" is deemed to be invalid. Copying or excerpting portion of, or altering the content of the report is not permitted without the written authorization of AGC. The test results presented in the report apply only to the tested sample. Any objections to report issued by AGC should be submitted to AGC within 15days after the issuance of the test report. Further enquiry of validity or verification of the test report should be addressed to AGC by agc01@agccert.com.

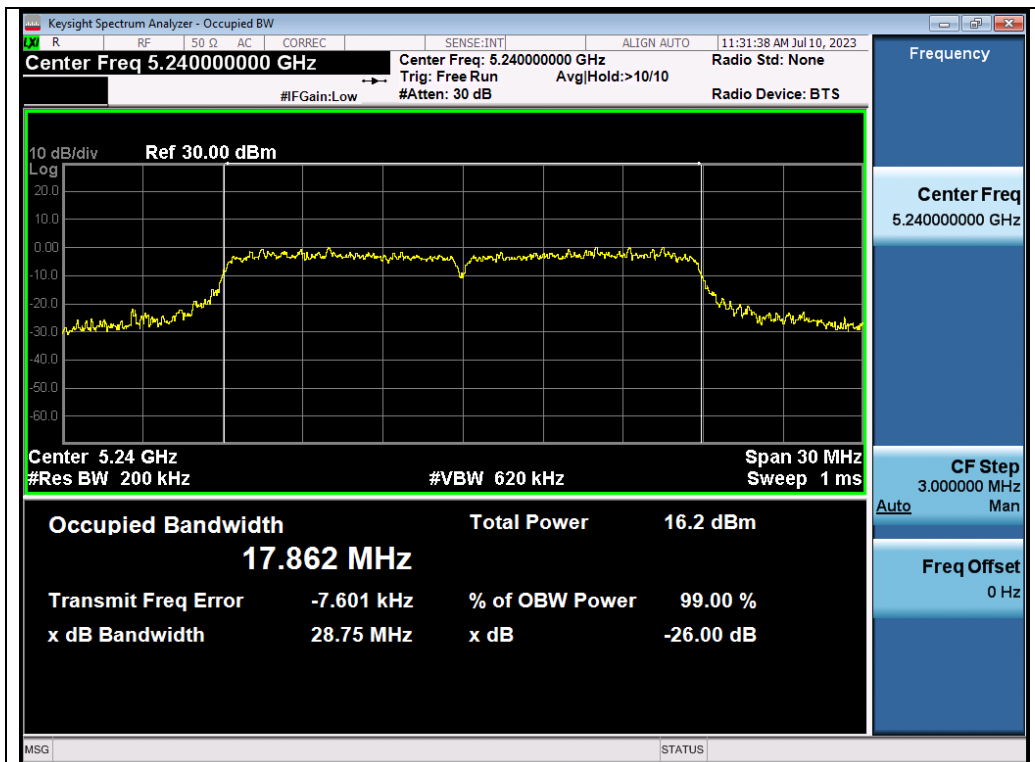

Test_Graph_802.11ac20_ANT1_5240_MCS9_OBW

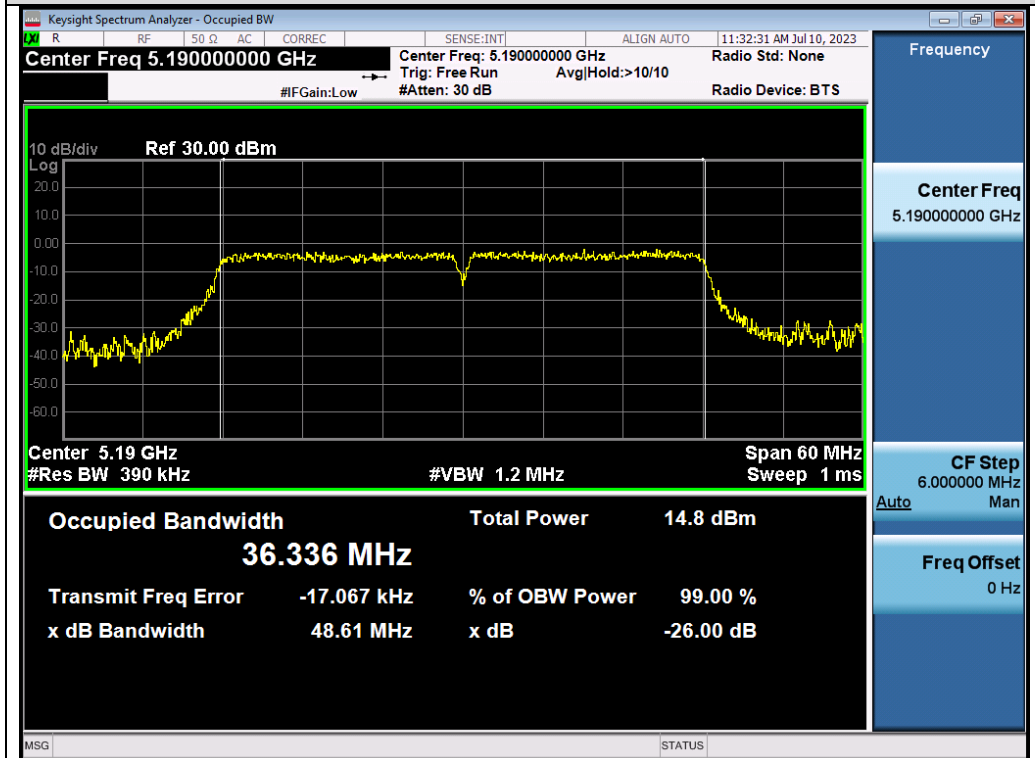

Test_Graph_802.11ac40_ANT1_5190_MCS9_OBW

Any report having not been signed by authorized approver, or having been altered without authorization, or having not been stamped by the "Dedicated Testing/Inspection Stamp" is deemed to be invalid. Copying or excerpting portion of, or altering the content of the report is not permitted without the written authorization of AGC. The test results presented in the report apply only to the tested sample. Any objections to report issued by AGC should be submitted to AGC within 15days after the issuance of the test report. Further enquiry of validity or verification of the test report should be addressed to AGC by agc01@agccert.com.

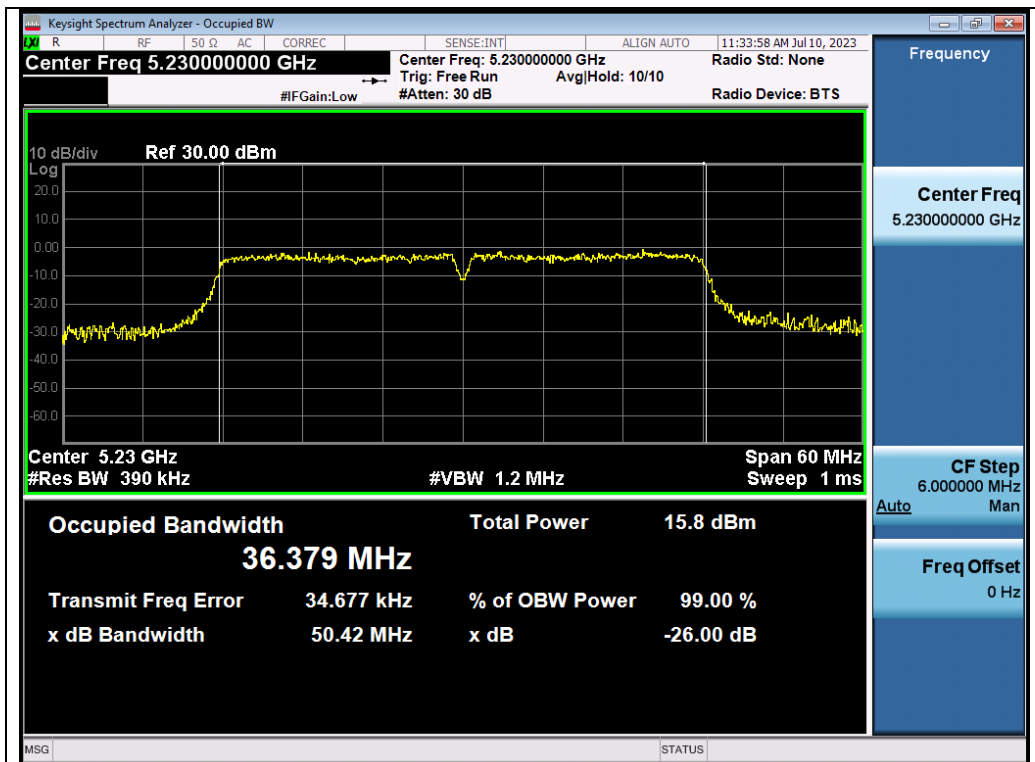

Test_Graph_802.11ac40_ANT1_5230_MCS9_OBW

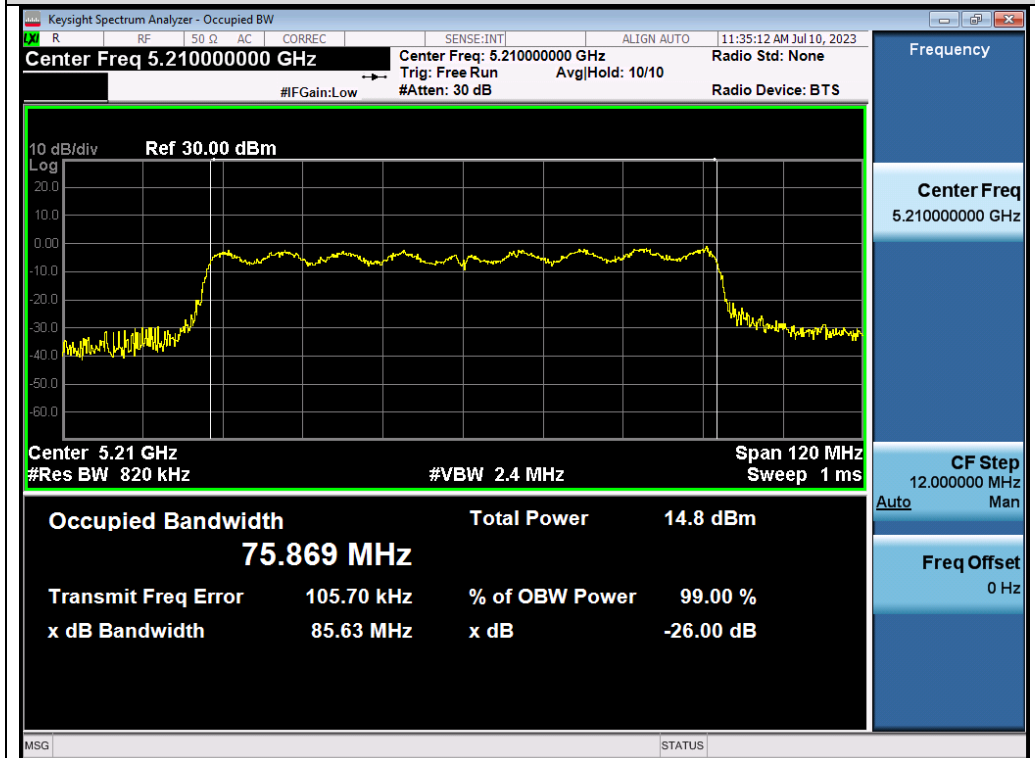

Test_Graph_802.11ac80_ANT1_5210_MCS9_OBW

Any report having not been signed by authorized approver, or having been altered without authorization, or having not been stamped by the "Dedicated Testing/Inspection Stamp" is deemed to be invalid. Copying or excerpting portion of, or altering the content of the report is not permitted without the written authorization of AGC. The test results presented in the report apply only to the tested sample. Any objections to report issued by AGC should be submitted to AGC within 15days after the issuance of the test report. Further enquiry of validity or verification of the test report should be addressed to AGC by agc01@agccert.com.

Test Graphs of Occupied Bandwidth for band 5.25-5.35 GHz

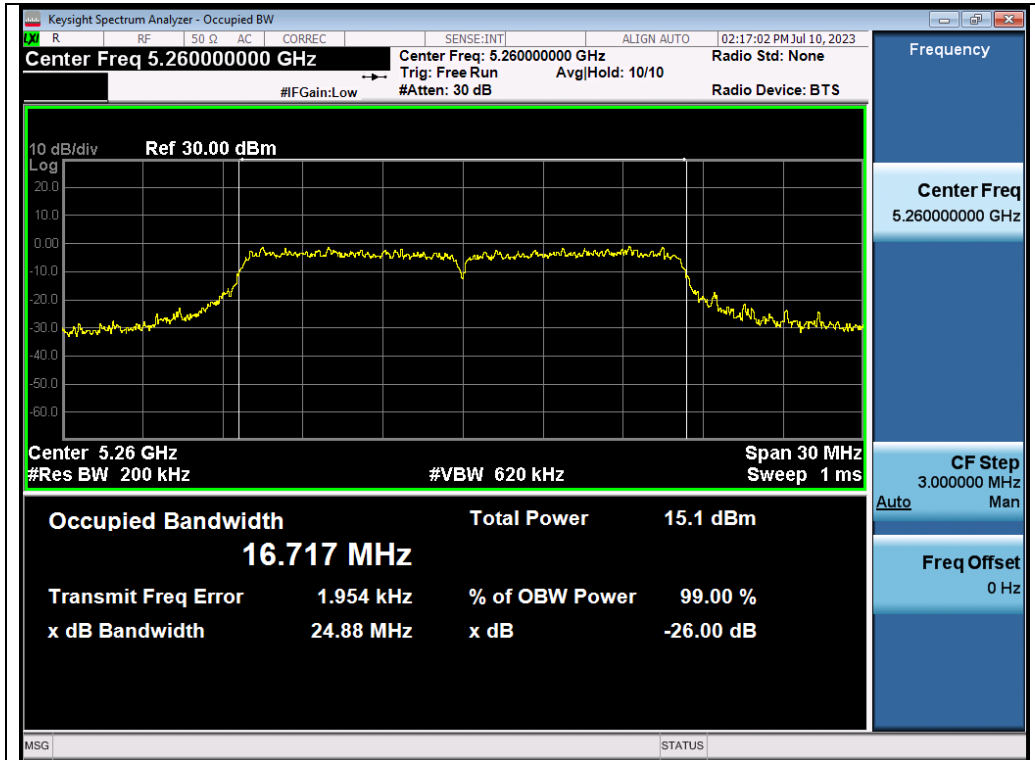

Test_Graph_802.11a_ANT1_5260_6Mbps_OBW

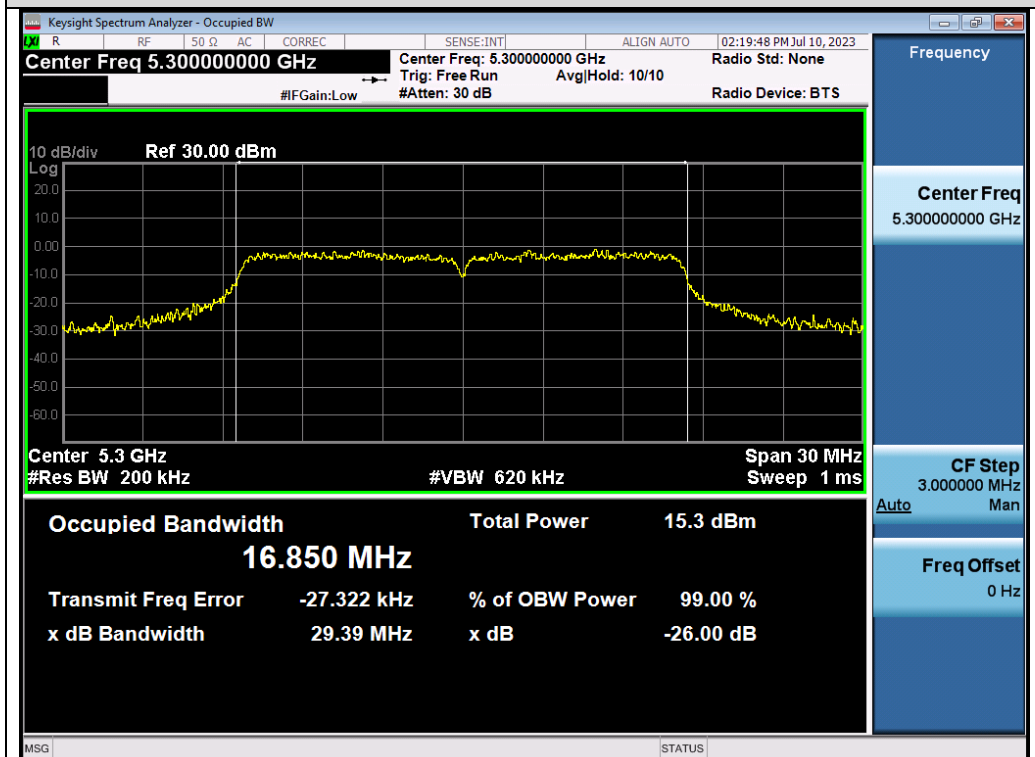

Test_Graph_802.11a_ANT1_5300_6Mbps_OBW

Any report having not been signed by authorized approver, or having been altered without authorization, or having not been stamped by the "Dedicated Testing/Inspection Stamp" is deemed to be invalid. Copying or excerpting portion of, or altering the content of the report is not permitted without the written authorization of AGC. The test results presented in the report apply only to the tested sample. Any objections to report issued by AGC should be submitted to AGC within 15days after the issuance of the test report. Further enquiry of validity or verification of the test report should be addressed to AGC by agc01@agccert.com.

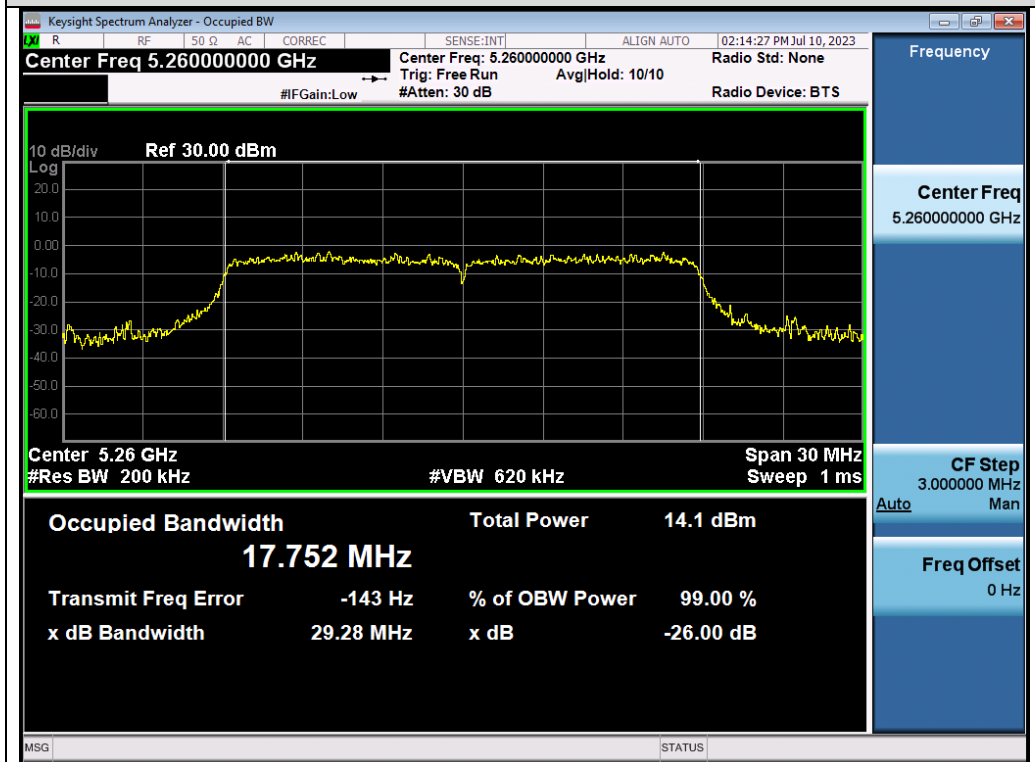
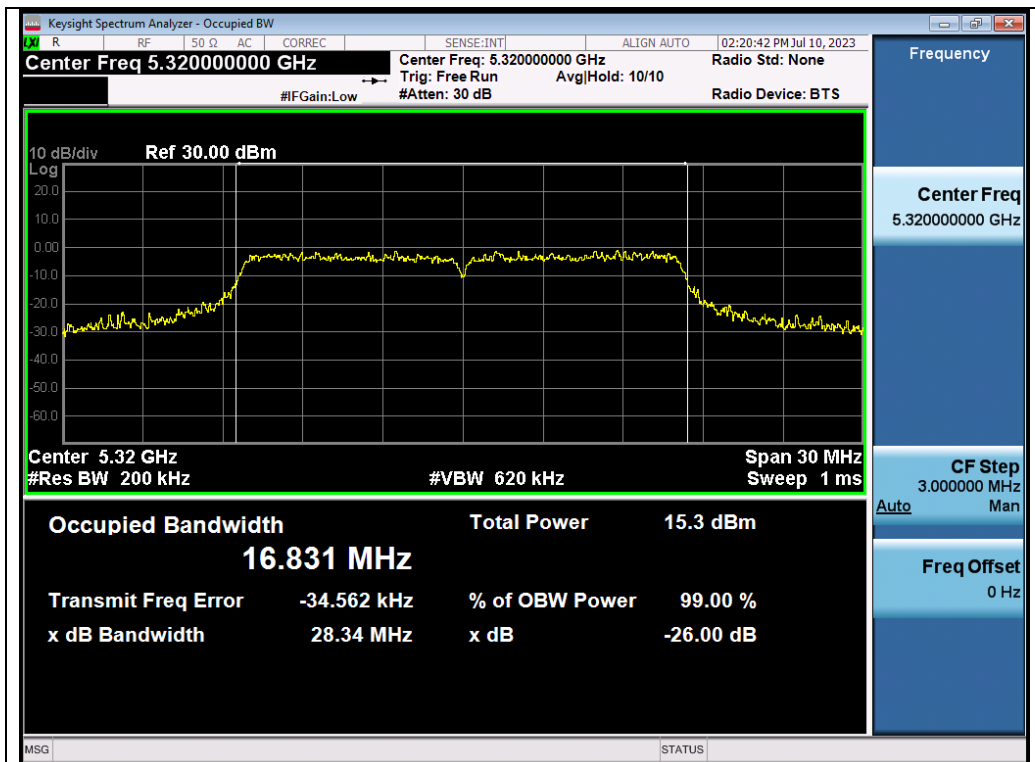

Any report having not been signed by authorized approver, or having been altered without authorization, or having not been stamped by the "Dedicated Testing/Inspection Stamp" is deemed to be invalid. Copying or excerpting portion of, or altering the content of the report is not permitted without the written authorization of AGC. The test results presented in the report apply only to the tested sample. Any objections to report issued by AGC should be submitted to AGC within 15days after the issuance of the test report. Further enquiry of validity or verification of the test report should be addressed to AGC by agc01@agccert.com.

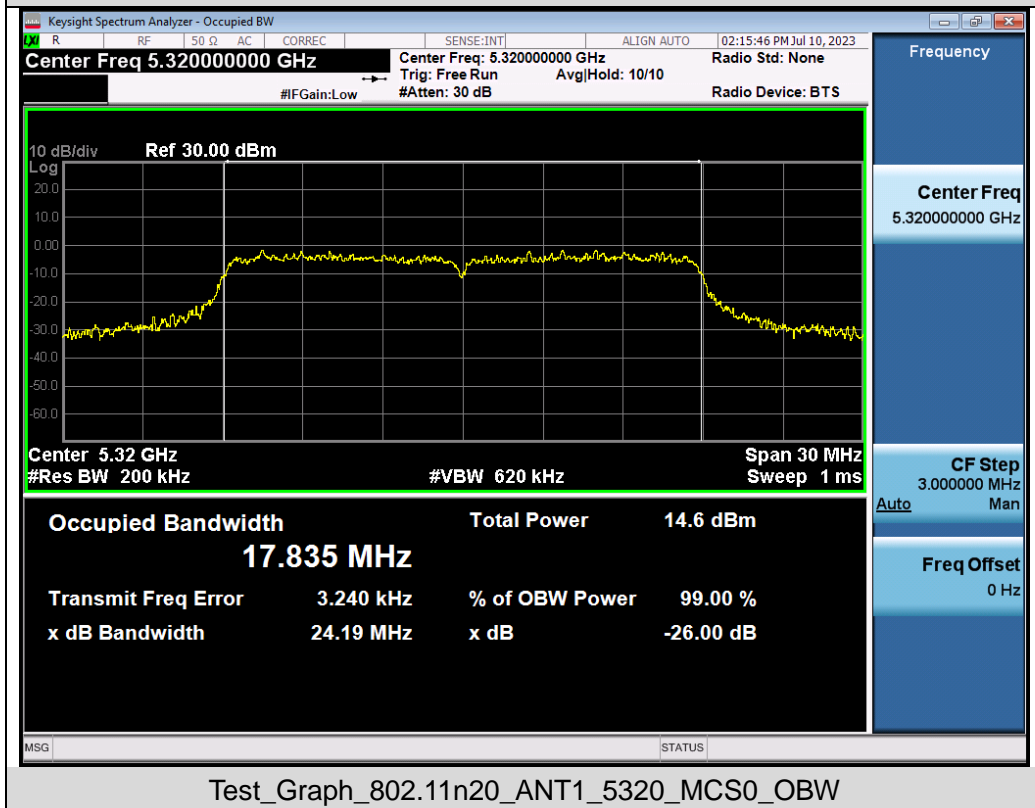
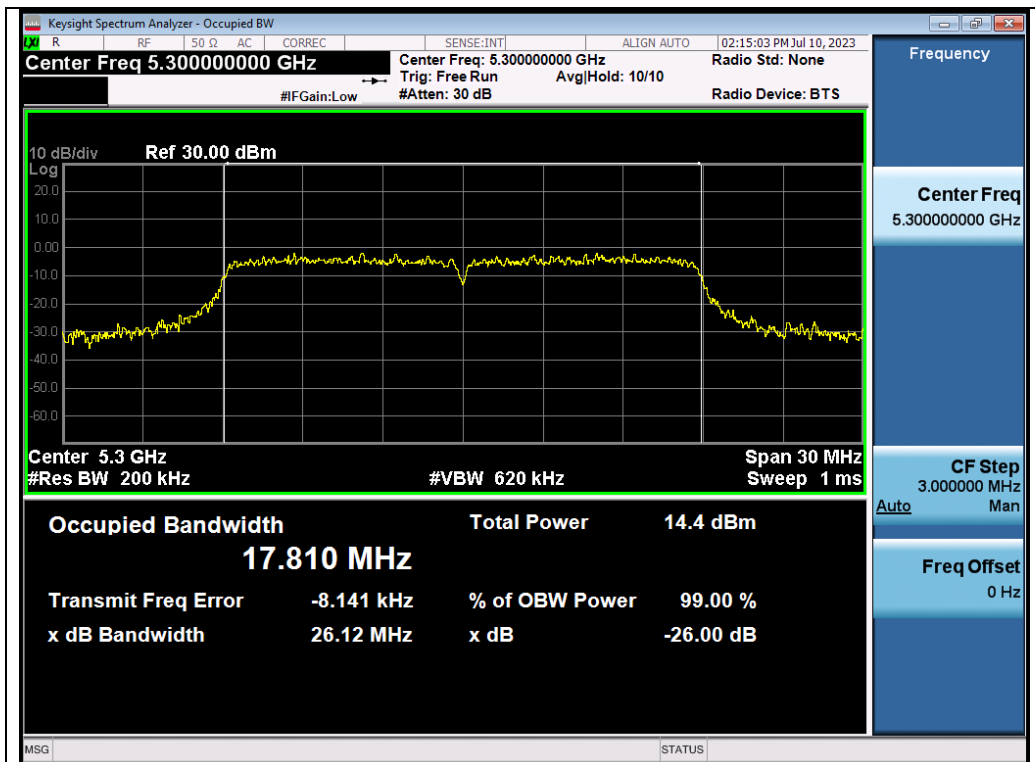

Any report having not been signed by authorized approver, or having been altered without authorization, or having not been stamped by the "Dedicated Testing/Inspection Stamp" is deemed to be invalid. Copying or excerpting portion of, or altering the content of the report is not permitted without the written authorization of AGC. The test results presented in the report apply only to the tested sample. Any objections to report issued by AGC should be submitted to AGC within 15days after the issuance of the test report. Further enquiry of validity or verification of the test report should be addressed to AGC by agc01@agccert.com.

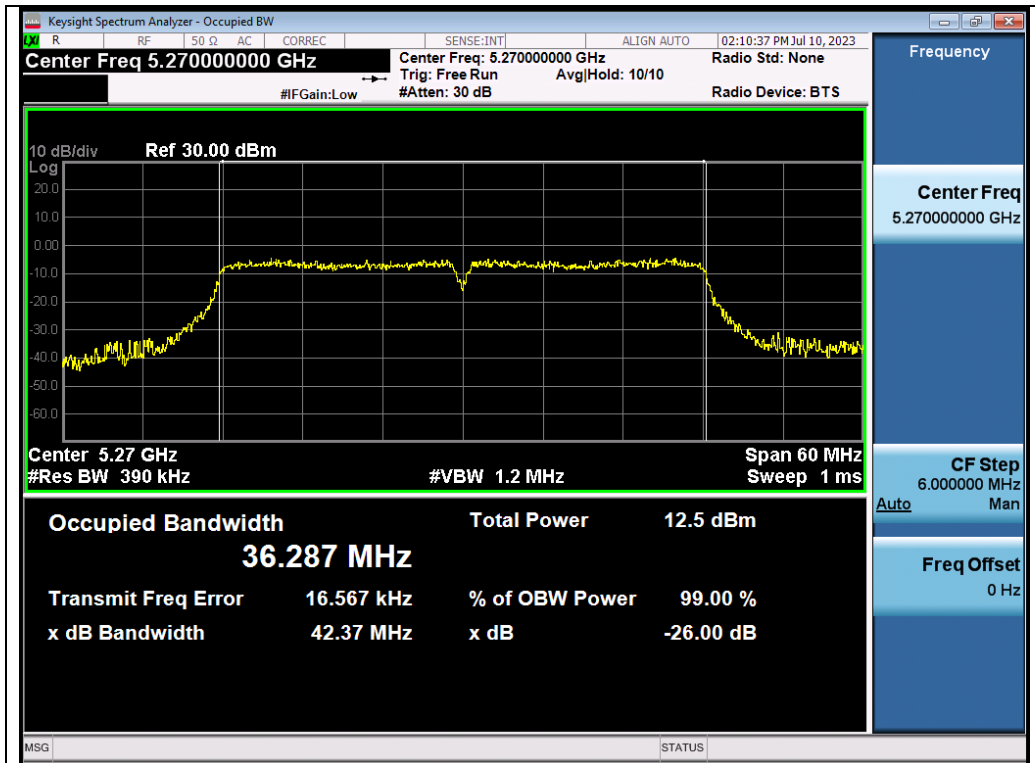

Test_Graph_802.11n40_ANT1_5270_MCS0_OBW

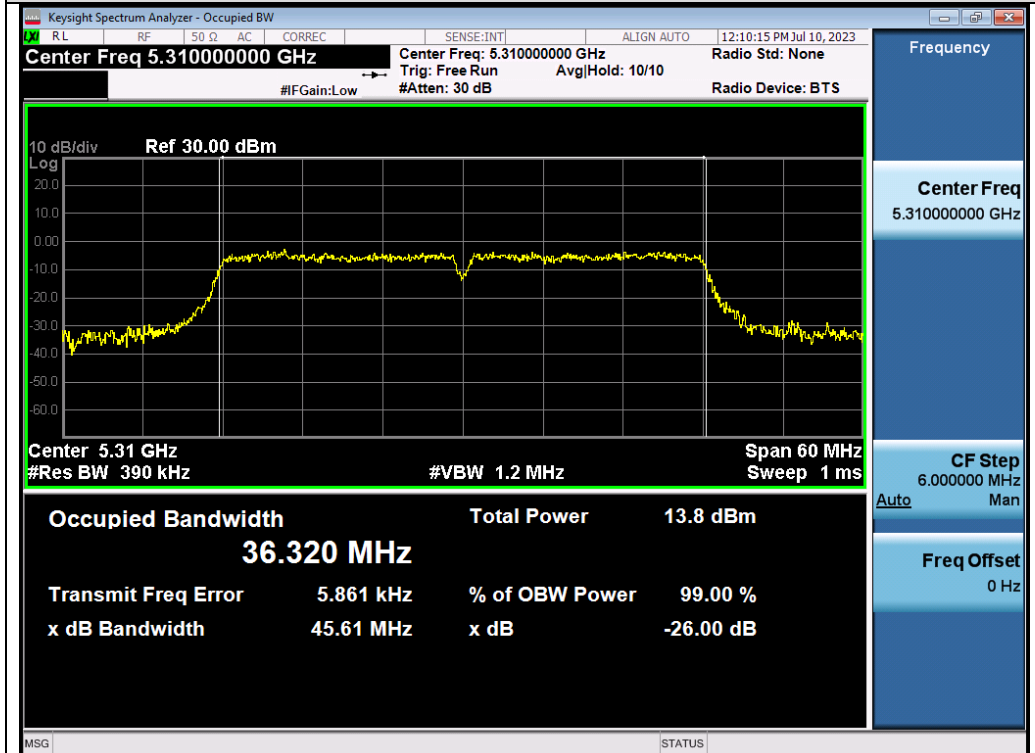

Test_Graph_802.11n40_ANT1_5310_MCS0_OBW

Any report having not been signed by authorized approver, or having been altered without authorization, or having not been stamped by the "Dedicated Testing/Inspection Stamp" is deemed to be invalid. Copying or excerpting portion of, or altering the content of the report is not permitted without the written authorization of AGC. The test results presented in the report apply only to the tested sample. Any objections to report issued by AGC should be submitted to AGC within 15days after the issuance of the test report. Further enquiry of validity or verification of the test report should be addressed to AGC by agc01@agccert.com.

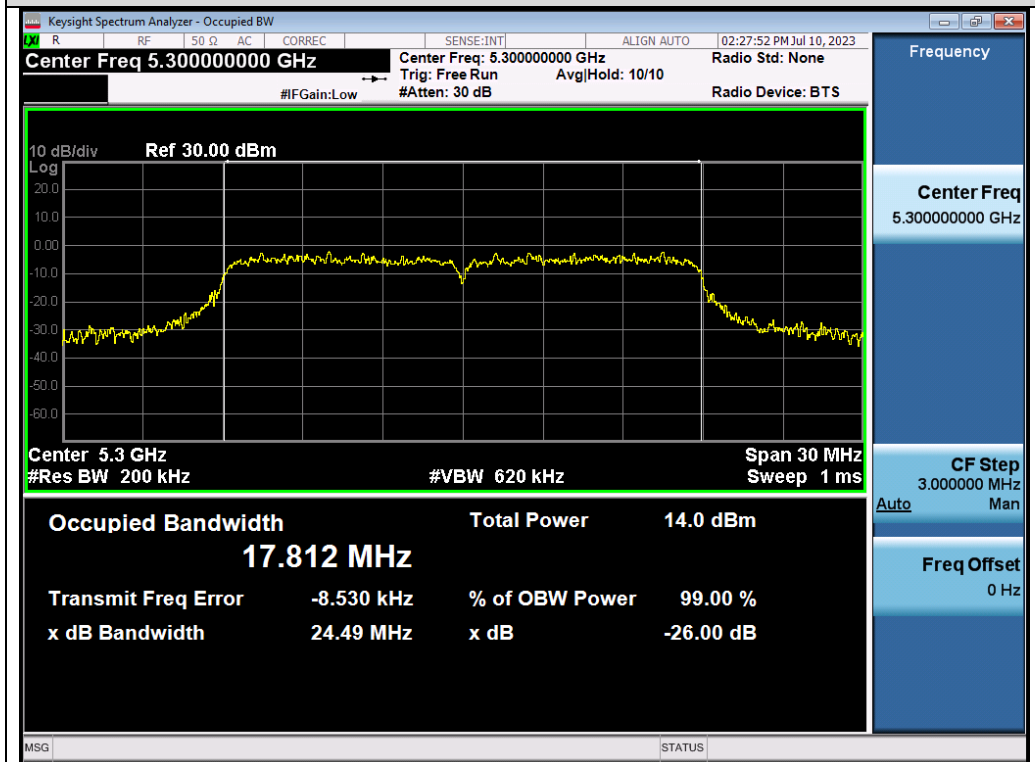
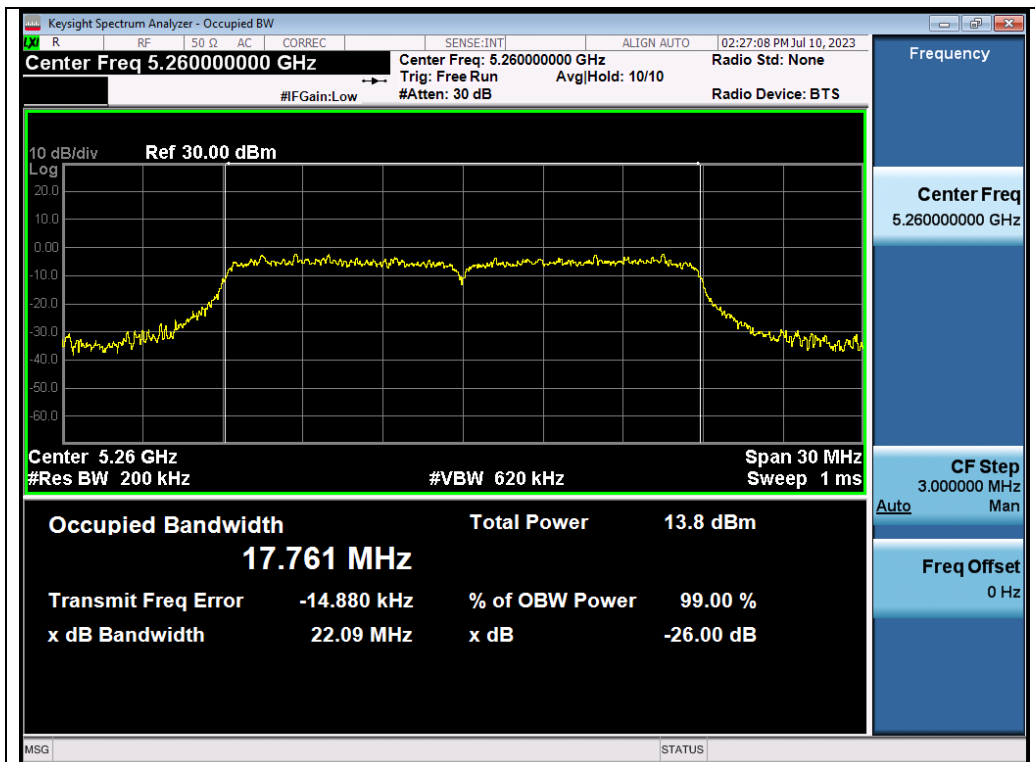

Any report having not been signed by authorized approver, or having been altered without authorization, or having not been stamped by the "Dedicated Testing/Inspection Stamp" is deemed to be invalid. Copying or excerpting portion of, or altering the content of the report is not permitted without the written authorization of AGC. The test results presented in the report apply only to the tested sample. Any objections to report issued by AGC should be submitted to AGC within 15days after the issuance of the test report. Further enquiry of validity or verification of the test report should be addressed to AGC by agc01@agccert.com.

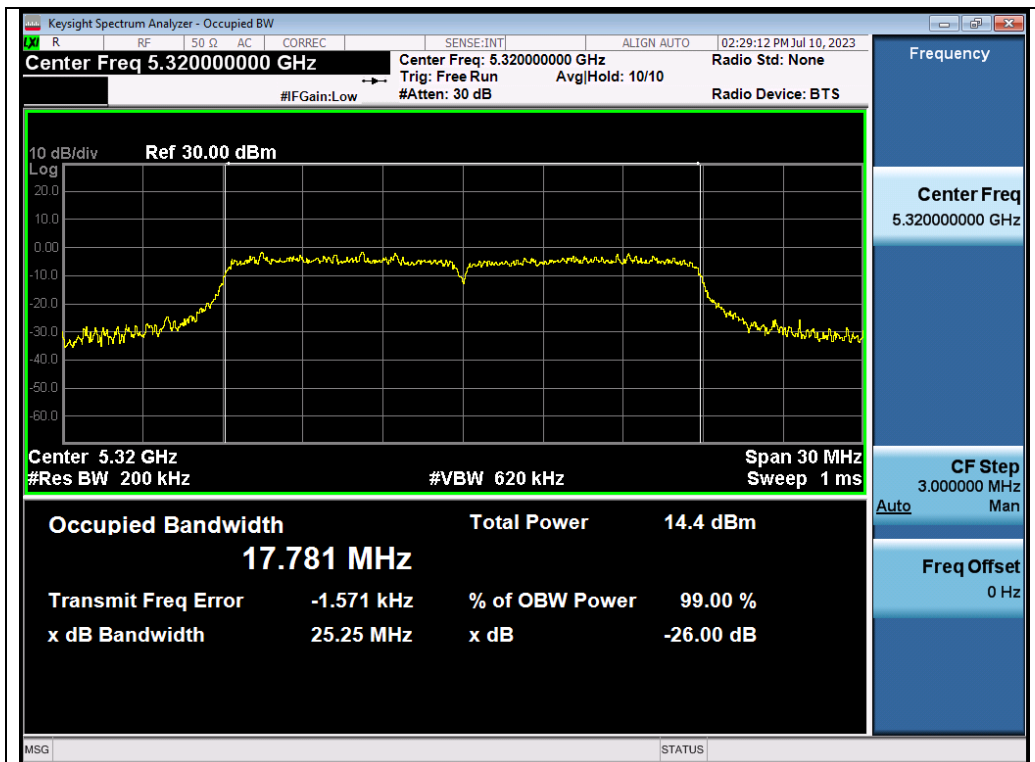

Test_Graph_802.11ac20_ANT1_5320_MCS9_OBW

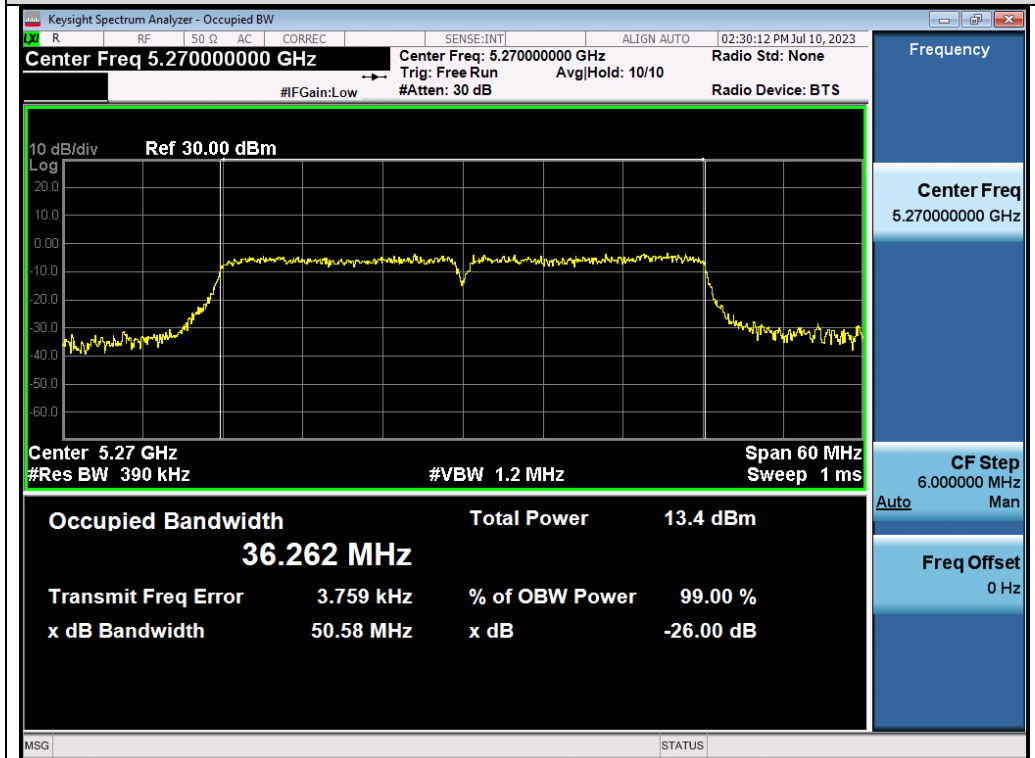

Test_Graph_802.11ac40_ANT1_5270_MCS9_OBW

Any report having not been signed by authorized approver, or having been altered without authorization, or having not been stamped by the "Dedicated Testing/Inspection Stamp" is deemed to be invalid. Copying or excerpting portion of, or altering the content of the report is not permitted without the written authorization of AGC. The test results presented in the report apply only to the tested sample. Any objections to report issued by AGC should be submitted to AGC within 15days after the issuance of the test report. Further enquiry of validity or verification of the test report should be addressed to AGC by agc01@agccert.com.

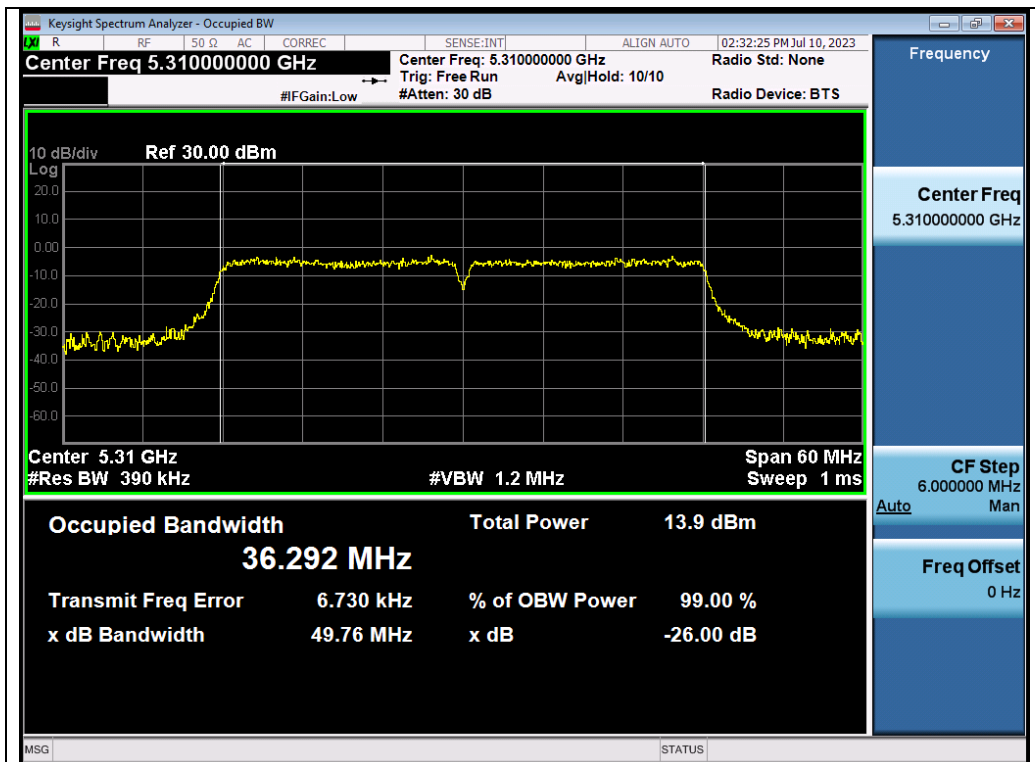

Test_Graph_802.11ac40_ANT1_5310_MCS9_OBW

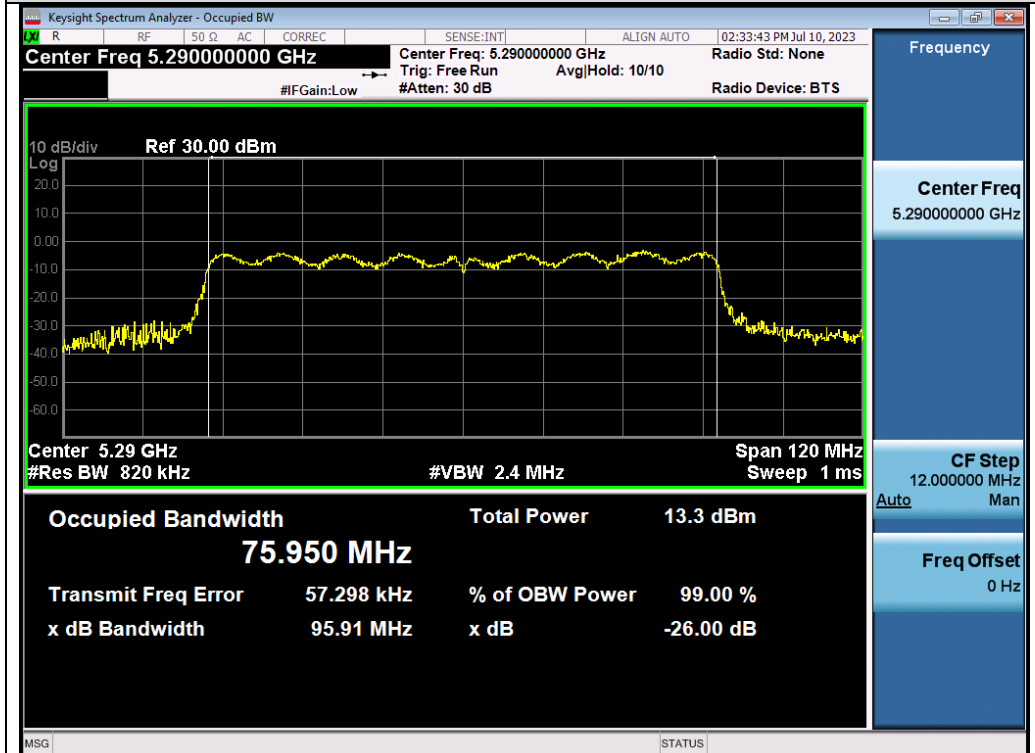

Test_Graph_802.11ac80_ANT1_5290_MCS9_OBW

Any report having not been signed by authorized approver, or having been altered without authorization, or having not been stamped by the "Dedicated Testing/Inspection Stamp" is deemed to be invalid. Copying or excerpting portion of, or altering the content of the report is not permitted without the written authorization of AGC. The test results presented in the report apply only to the tested sample. Any objections to report issued by AGC should be submitted to AGC within 15days after the issuance of the test report. Further enquiry of validity or verification of the test report should be addressed to AGC by agc01@agccert.com.

Test Graphs of Occupied Bandwidth and -26dB Bandwidth for band 5.470-5.725 GHz

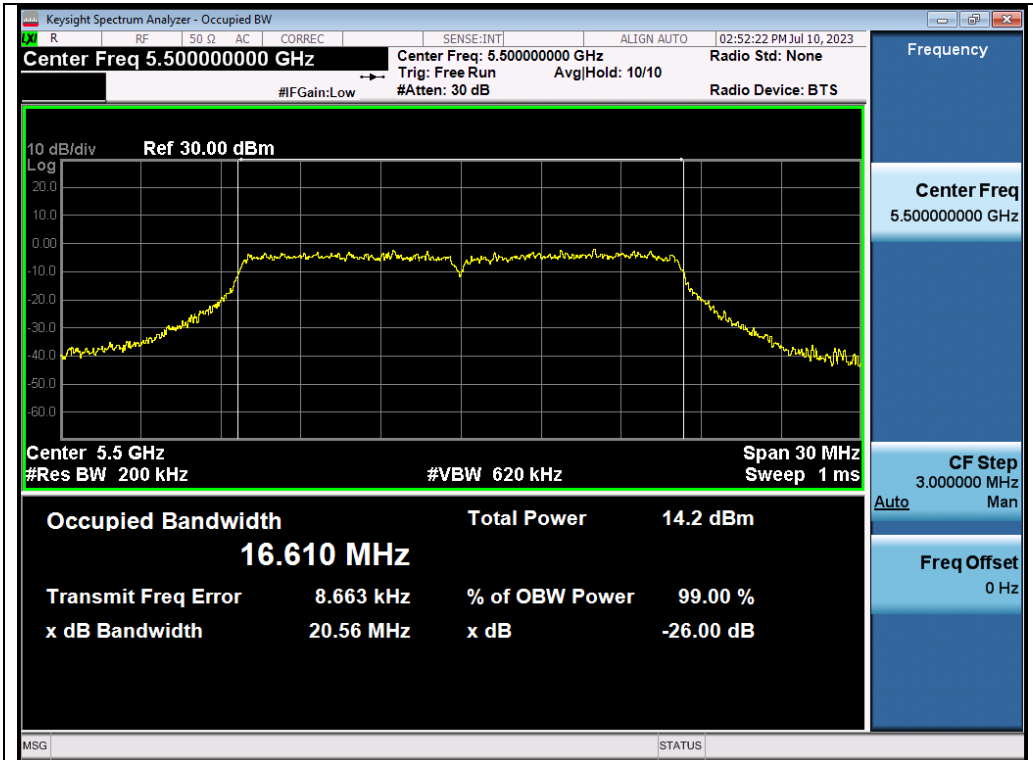

Test_Graph_802.11a_ANT1_5500_6Mbps_OBW

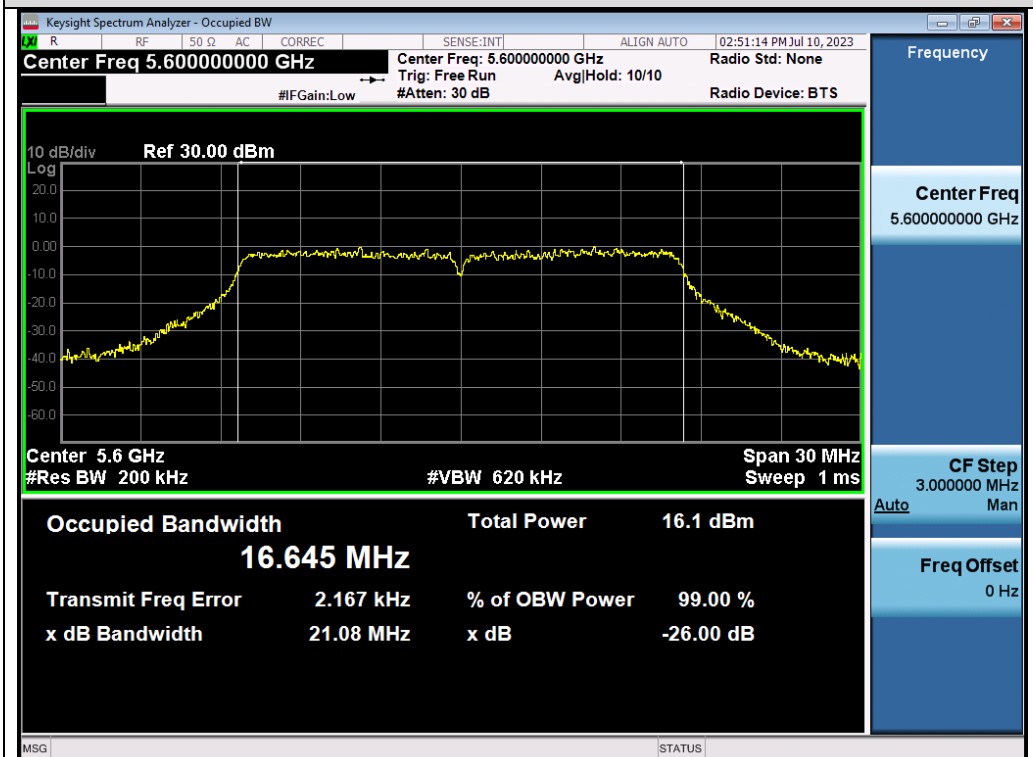

Test_Graph_802.11a_ANT1_5600_6Mbps_OBW

Any report having not been signed by authorized approver, or having been altered without authorization, or having not been stamped by the "Dedicated Testing/Inspection Stamp" is deemed to be invalid. Copying or excerpting portion of, or altering the content of the report is not permitted without the written authorization of AGC. The test results presented in the report apply only to the tested sample. Any objections to report issued by AGC should be submitted to AGC within 15days after the issuance of the test report. Further enquiry of validity or verification of the test report should be addressed to AGC by agc01@agccert.com.

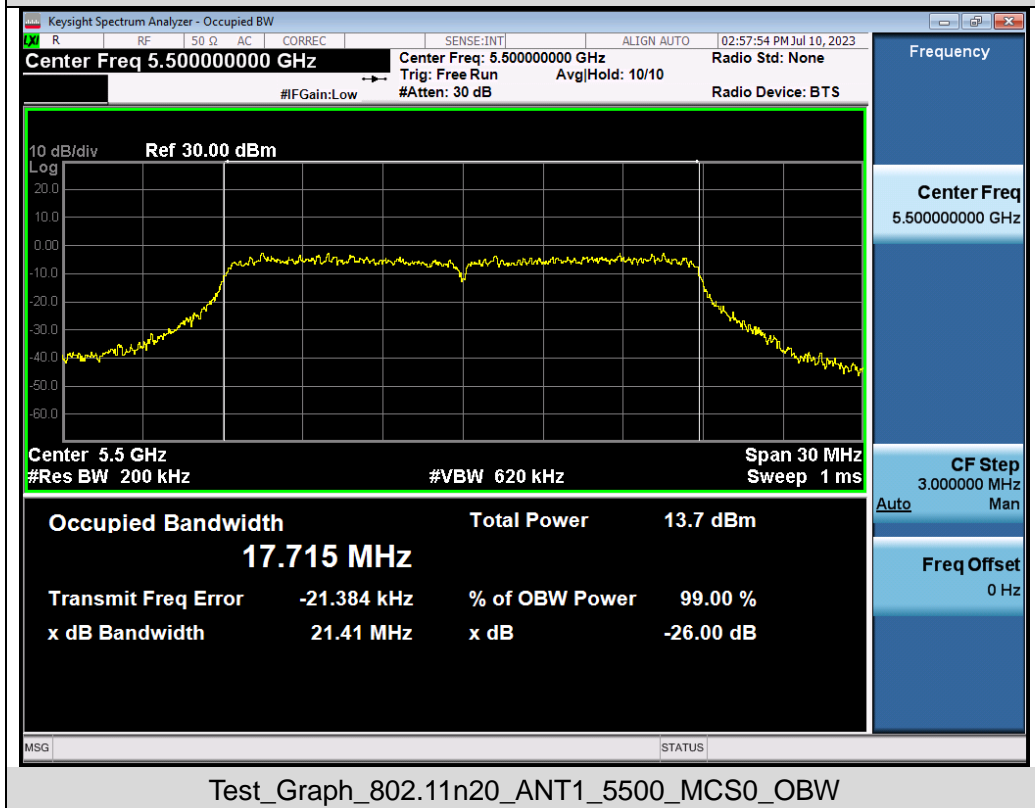
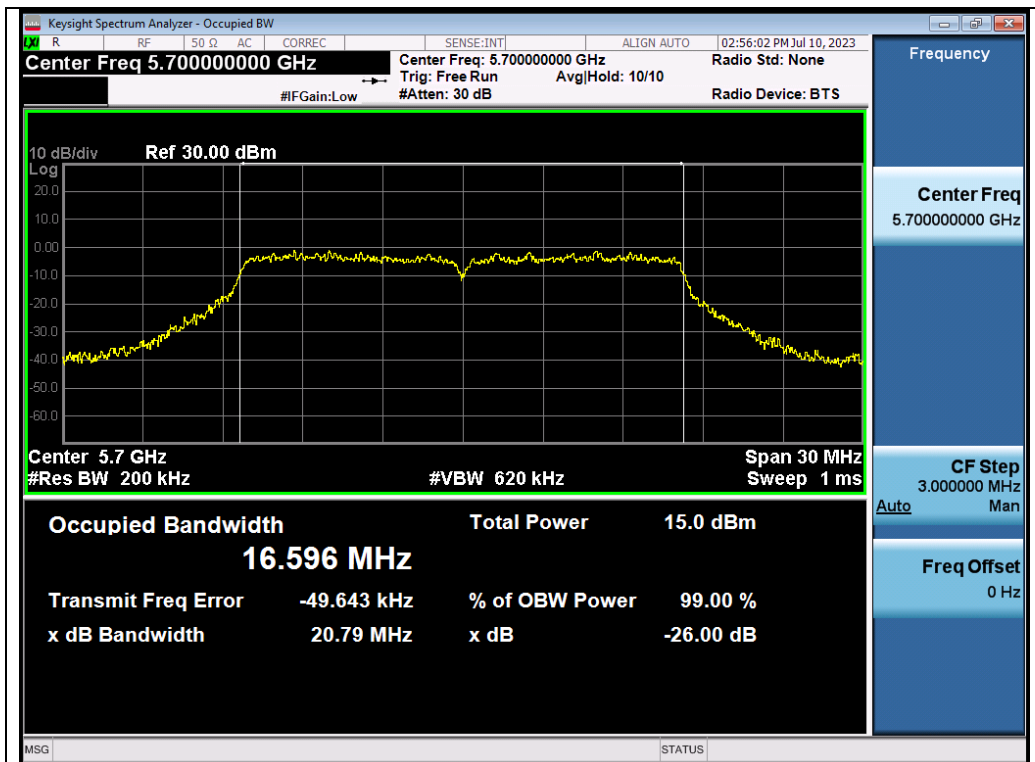

Any report having not been signed by authorized approver, or having been altered without authorization, or having not been stamped by the "Dedicated Testing/Inspection Stamp" is deemed to be invalid. Copying or excerpting portion of, or altering the content of the report is not permitted without the written authorization of AGC. The test results presented in the report apply only to the tested sample. Any objections to report issued by AGC should be submitted to AGC within 15days after the issuance of the test report. Further enquiry of validity or verification of the test report should be addressed to AGC by agc01@agccert.com.

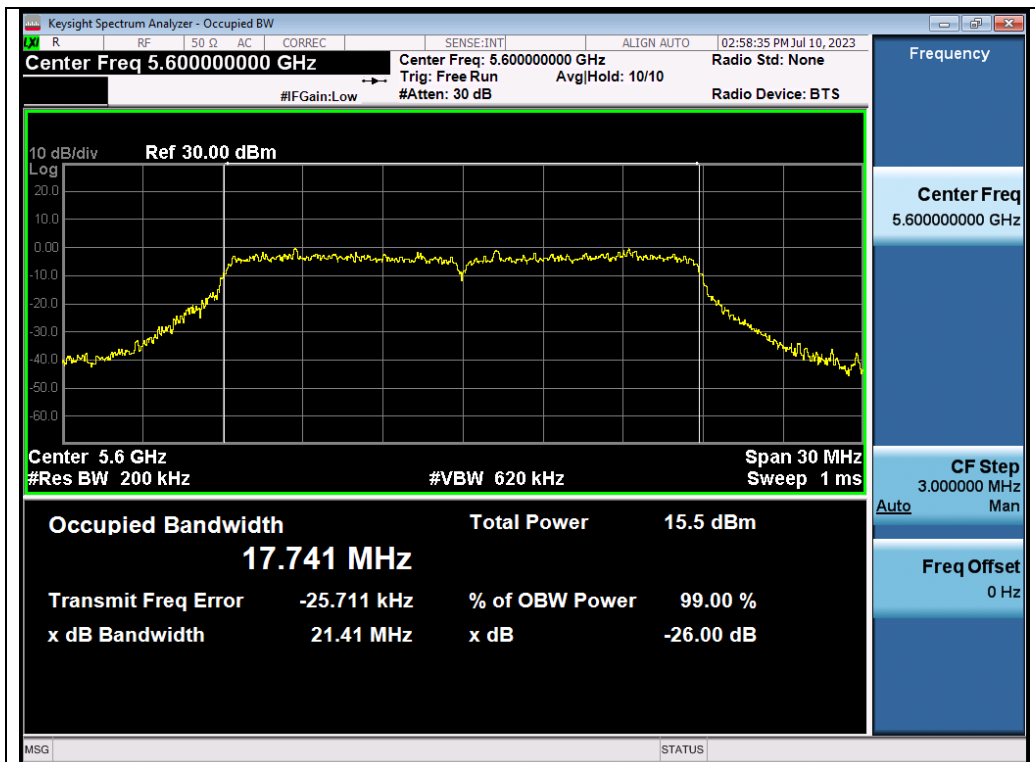

Test_Graph_802.11n20_ANT1_5600_MCS0_OBW

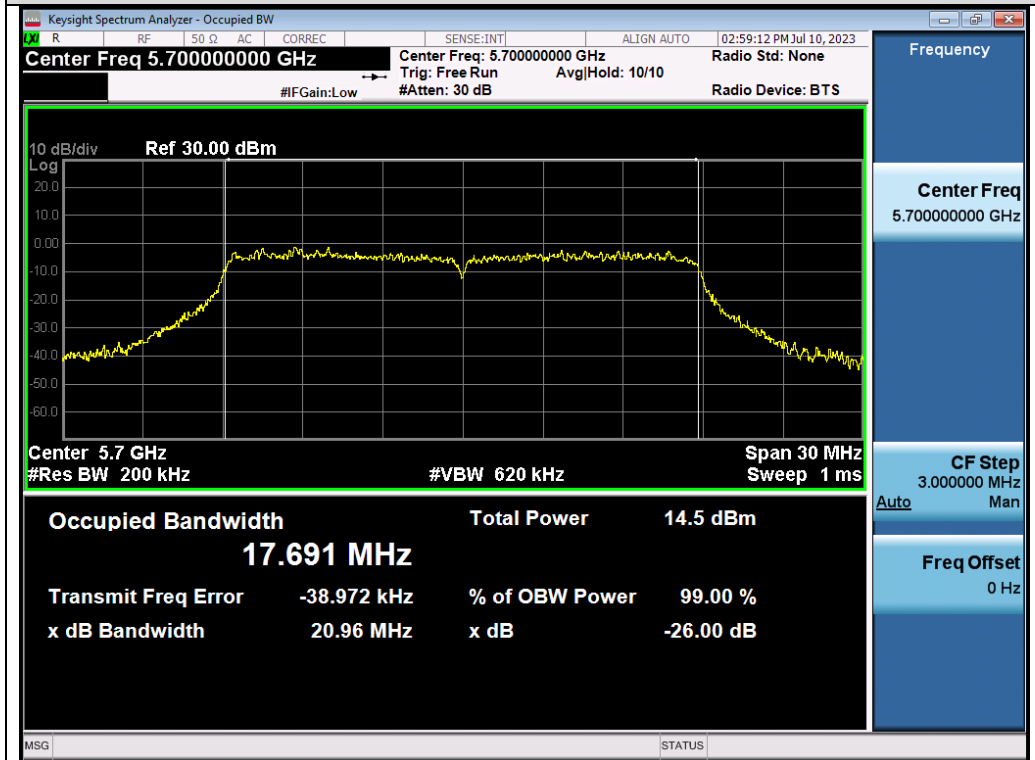

Test_Graph_802.11n20_ANT1_5700_MCS0_OBW

Any report having not been signed by authorized approver, or having been altered without authorization, or having not been stamped by the "Dedicated Testing/Inspection Stamp" is deemed to be invalid. Copying or excerpting portion of, or altering the content of the report is not permitted without the written authorization of AGC. The test results presented in the report apply only to the tested sample. Any objections to report issued by AGC should be submitted to AGC within 15days after the issuance of the test report. Further enquiry of validity or verification of the test report should be addressed to AGC by agc01@agccert.com.

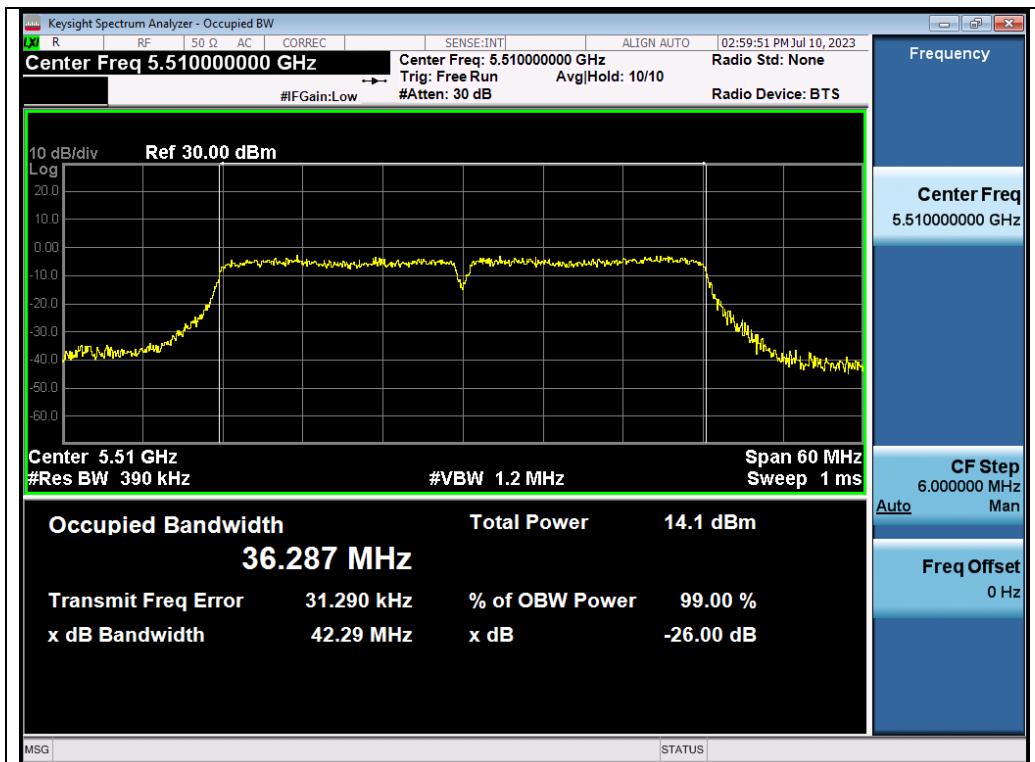

Test_Graph_802.11n40_ANT1_5510_MCS0_OBW

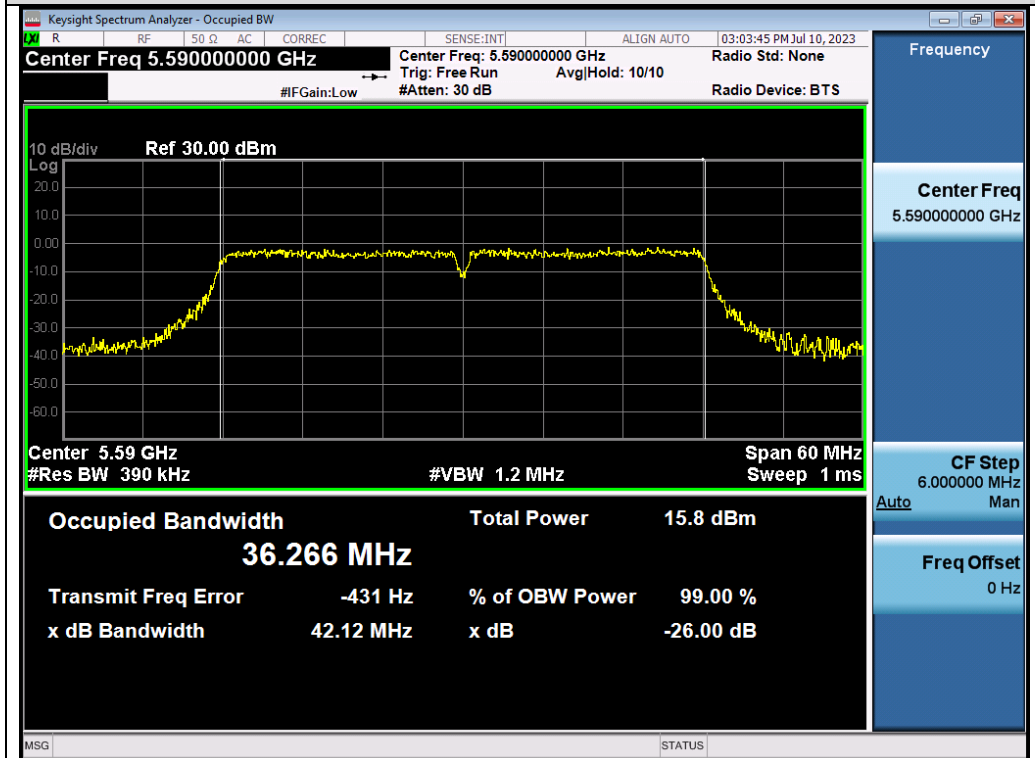

Test_Graph_802.11n40_ANT1_5590_MCS0_OBW

Any report having not been signed by authorized approver, or having been altered without authorization, or having not been stamped by the "Dedicated Testing/Inspection Stamp" is deemed to be invalid. Copying or excerpting portion of, or altering the content of the report is not permitted without the written authorization of AGC. The test results presented in the report apply only to the tested sample. Any objections to report issued by AGC should be submitted to AGC within 15days after the issuance of the test report. Further enquiry of validity or verification of the test report should be addressed to AGC by agc01@agccert.com.

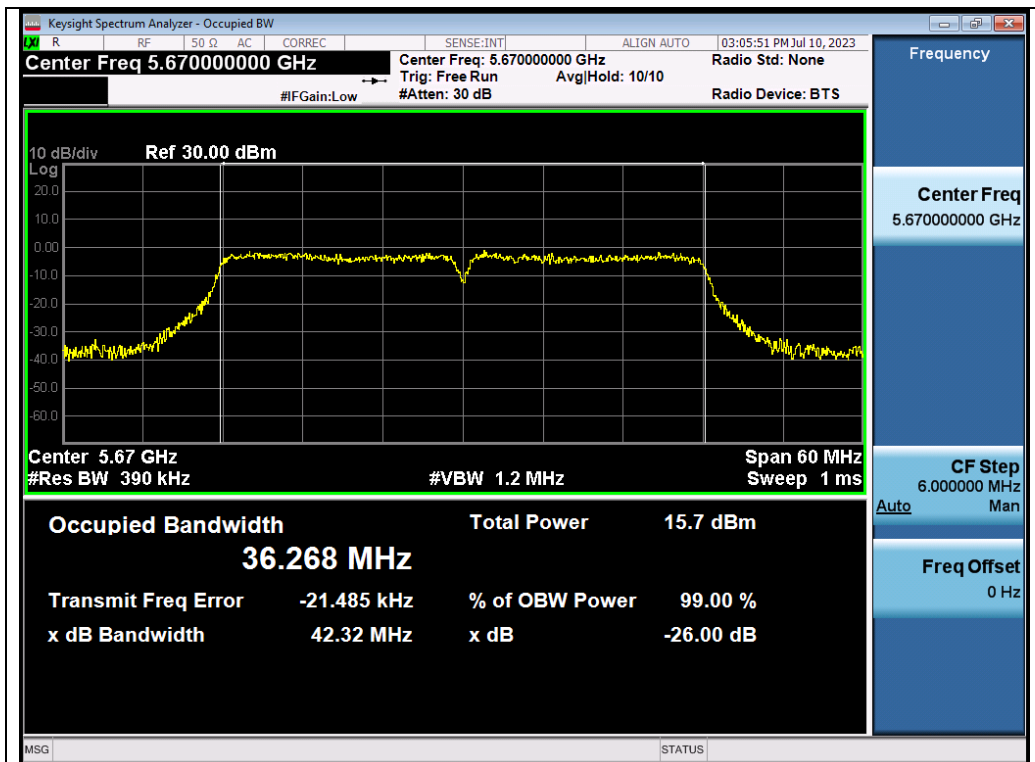

Test_Graph_802.11n40_ANT1_5670_MCS0_OBW

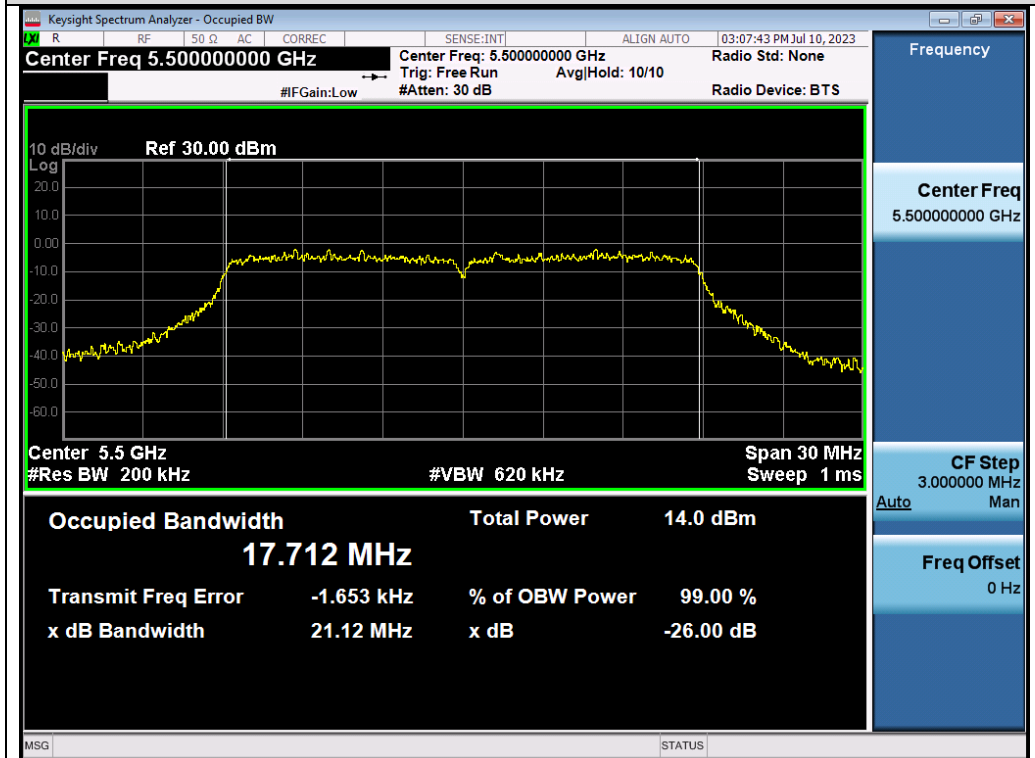

Test_Graph_802.11ac20_ANT1_5500_MCS0_OBW

Any report having not been signed by authorized approver, or having been altered without authorization, or having not been stamped by the "Dedicated Testing/Inspection Stamp" is deemed to be invalid. Copying or excerpting portion of, or altering the content of the report is not permitted without the written authorization of AGC. The test results presented in the report apply only to the tested sample. Any objections to report issued by AGC should be submitted to AGC within 15days after the issuance of the test report. Further enquiry of validity or verification of the test report should be addressed to AGC by agc01@agccert.com.

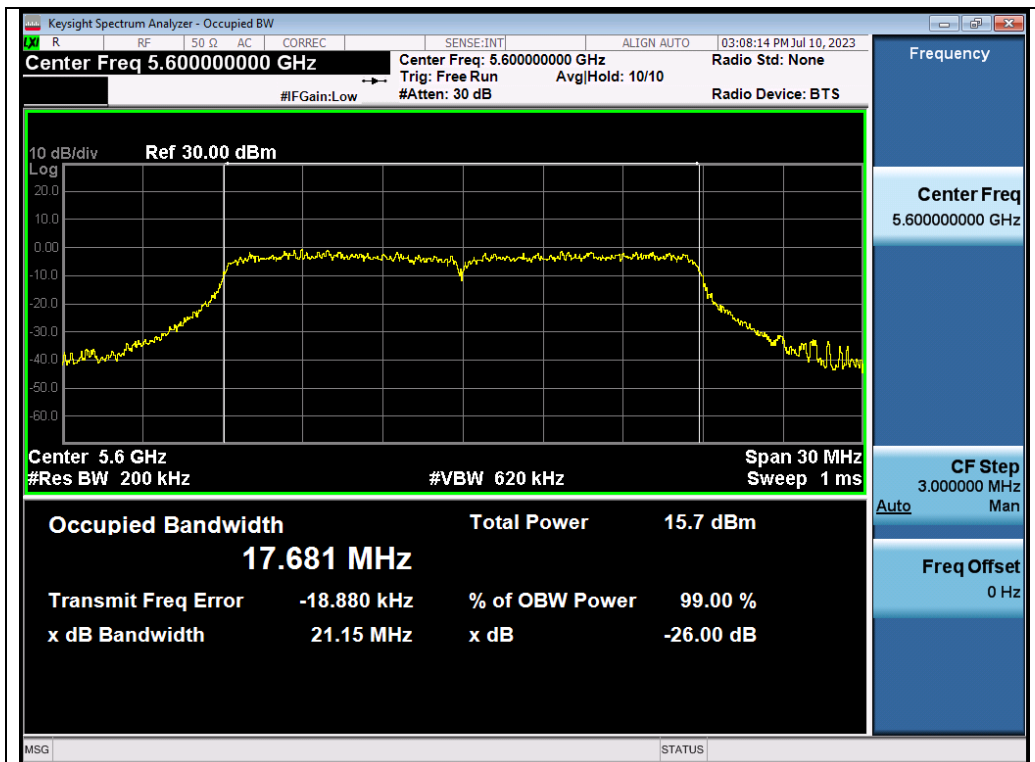

Test_Graph_802.11ac20_ANT1_5600_MCS0_OBW

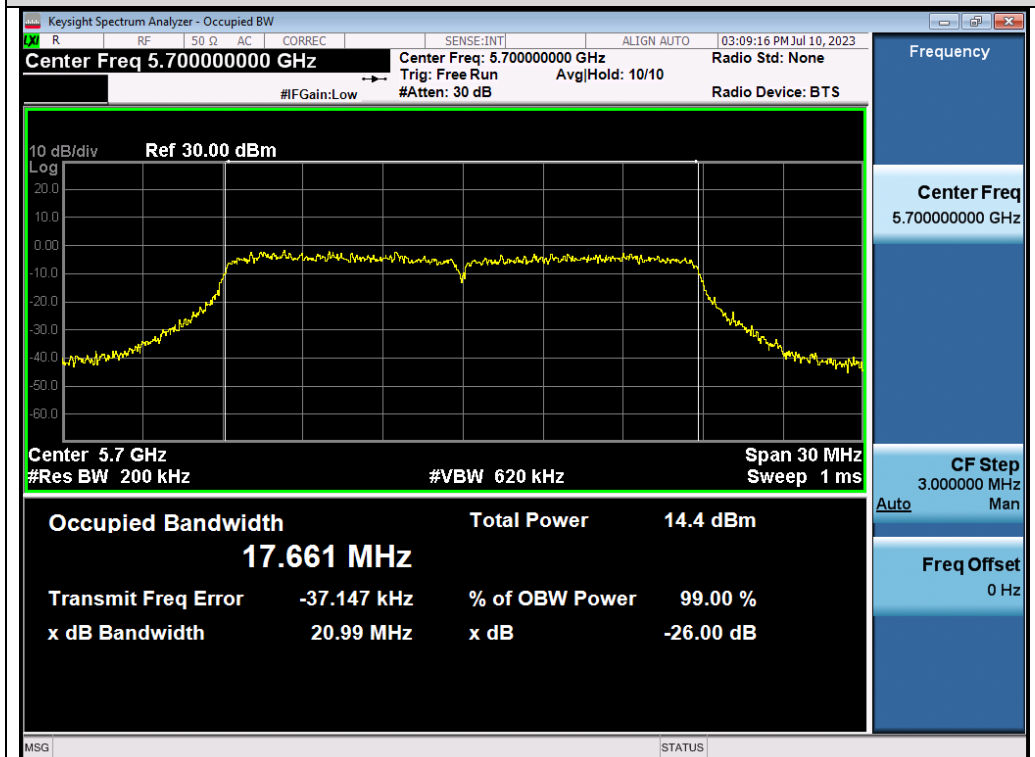

Test_Graph_802.11ac20_ANT1_5700_MCS9_OBW

Any report having not been signed by authorized approver, or having been altered without authorization, or having not been stamped by the "Dedicated Testing/Inspection Stamp" is deemed to be invalid. Copying or excerpting portion of, or altering the content of the report is not permitted without the written authorization of AGC. The test results presented in the report apply only to the tested sample. Any objections to report issued by AGC should be submitted to AGC within 15days after the issuance of the test report. Further enquiry of validity or verification of the test report should be addressed to AGC by agc01@agccert.com.

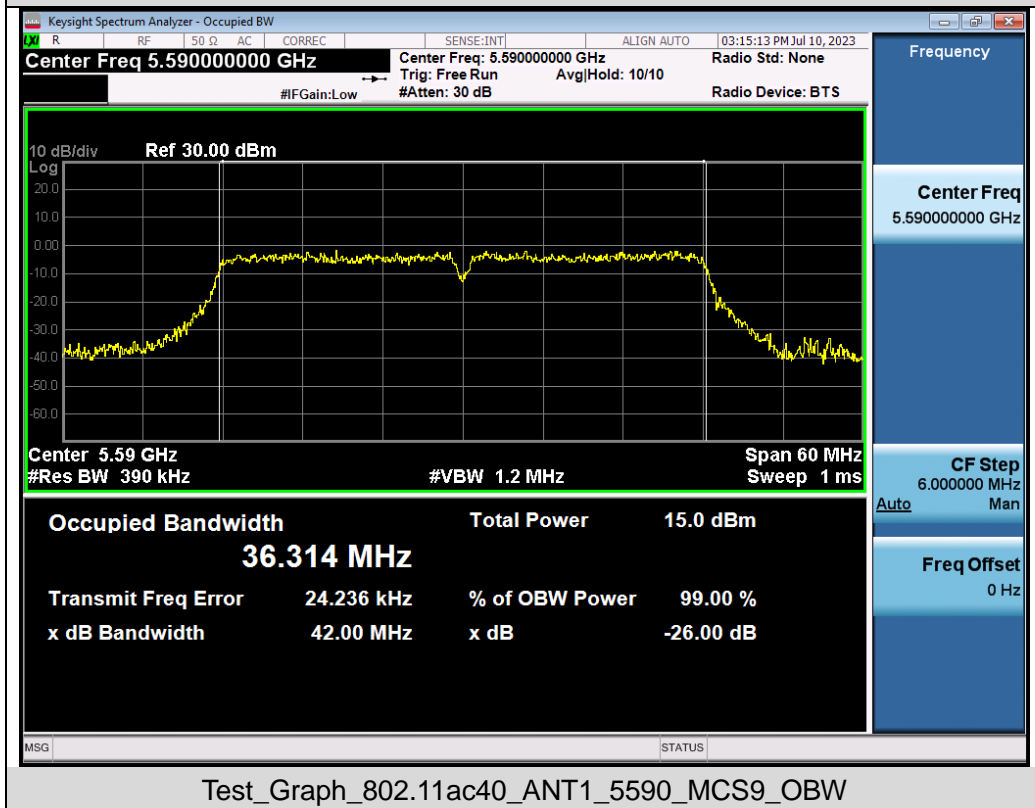
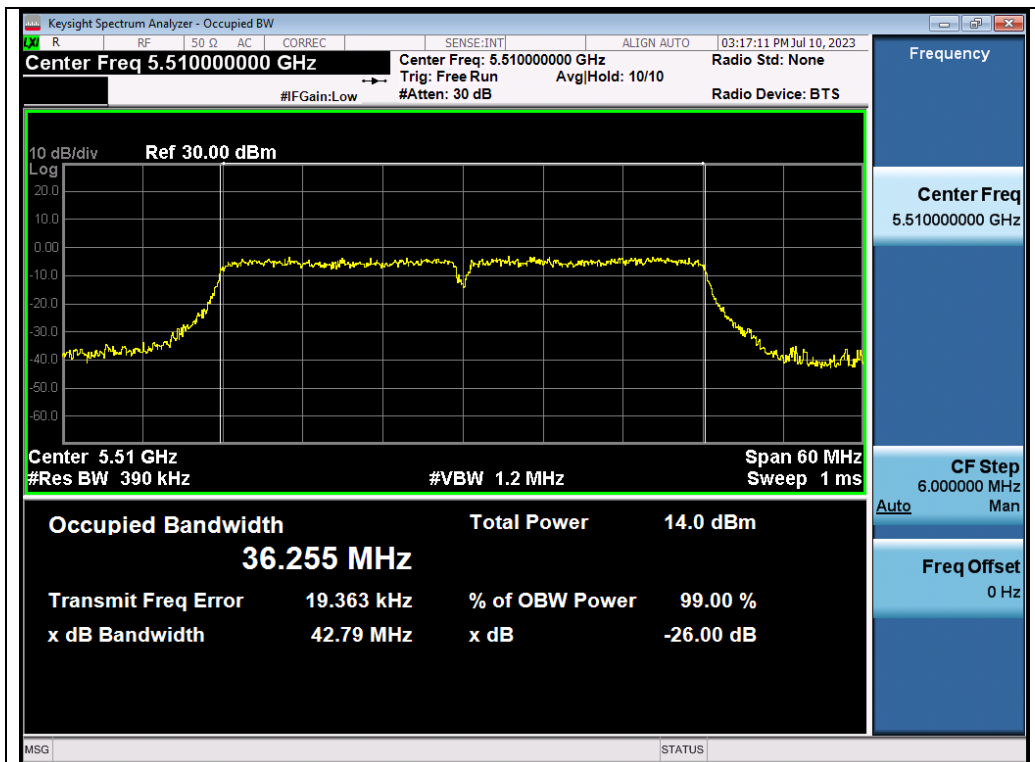

Any report having not been signed by authorized approver, or having been altered without authorization, or having not been stamped by the "Dedicated Testing/Inspection Stamp" is deemed to be invalid. Copying or excerpting portion of, or altering the content of the report is not permitted without the written authorization of AGC. The test results presented in the report apply only to the tested sample. Any objections to report issued by AGC should be submitted to AGC within 15days after the issuance of the test report. Further enquiry of validity or verification of the test report should be addressed to AGC by agc01@agccert.com.

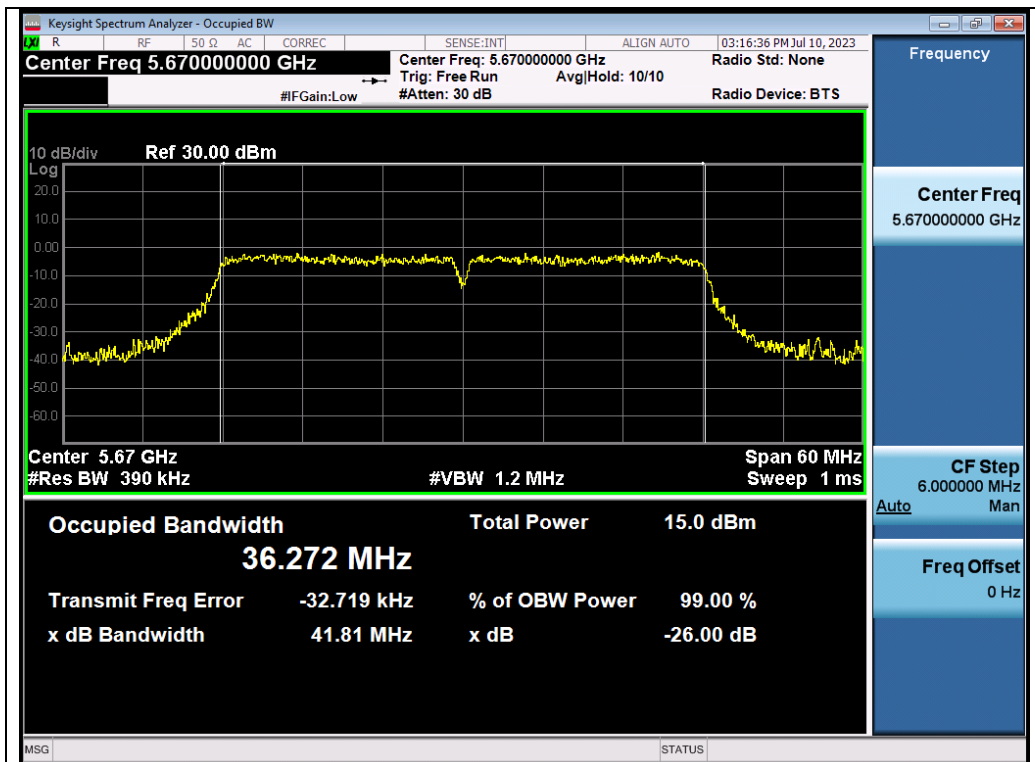

Test_Graph_802.11ac40_ANT1_5670_MCS9_OBW

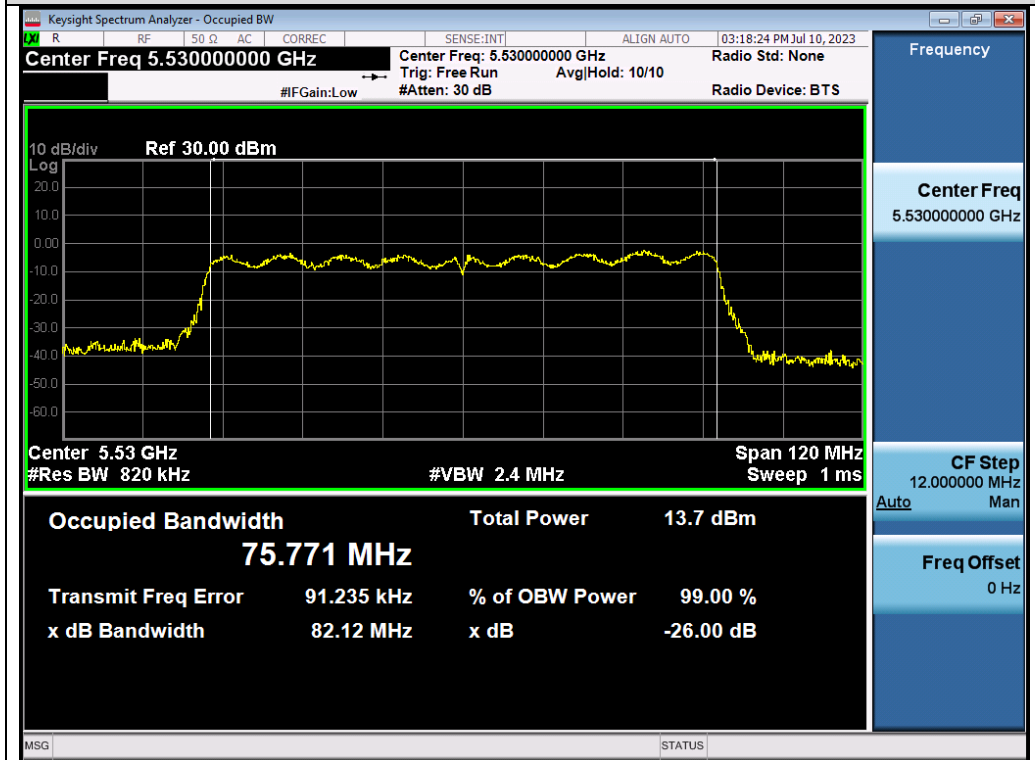

Test_Graph_802.11ac80_ANT1_5530_MCS9_OBW

Any report having not been signed by authorized approver, or having been altered without authorization, or having not been stamped by the "Dedicated Testing/Inspection Stamp" is deemed to be invalid. Copying or excerpting portion of, or altering the content of the report is not permitted without the written authorization of AGC. The test results presented in the report apply only to the tested sample. Any objections to report issued by AGC should be submitted to AGC within 15days after the issuance of the test report. Further enquiry of validity or verification of the test report should be addressed to AGC by agc01@agccert.com.

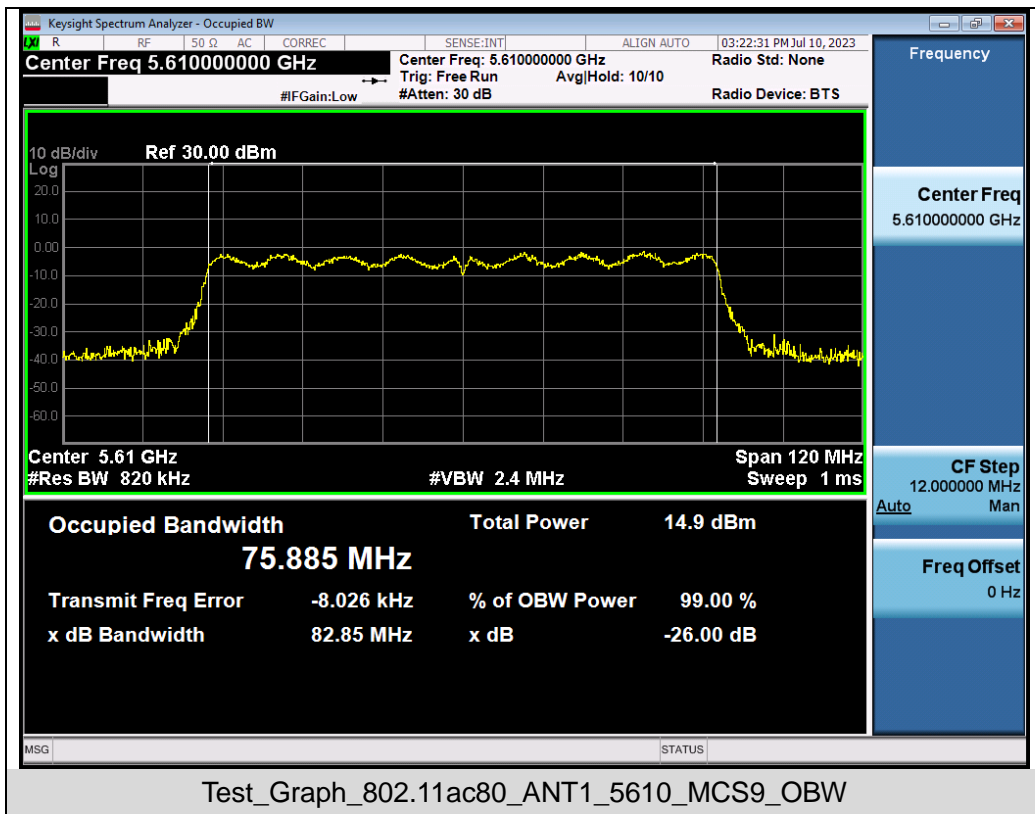

Test Graphs of Occupied Bandwidth and -26dB Bandwidth for band 5.725-5.825 GHz

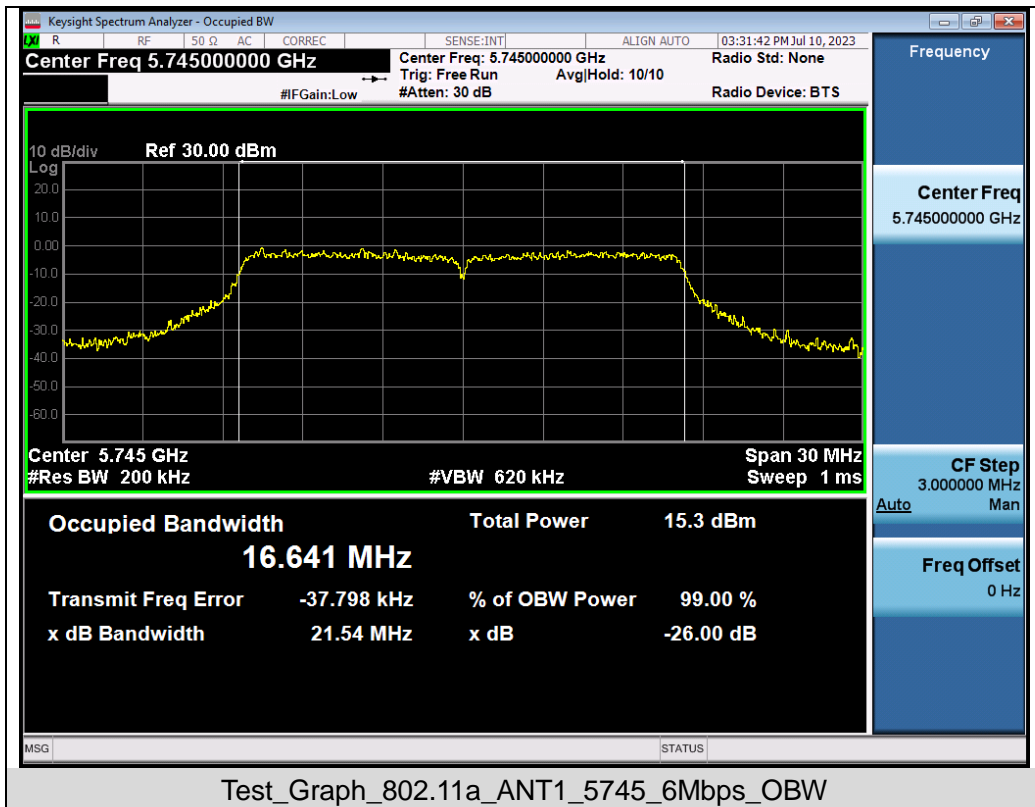

Any report having not been signed by authorized approver, or having been altered without authorization, or having not been stamped by the "Dedicated Testing/Inspection Stamp" is deemed to be invalid. Copying or excerpting portion of, or altering the content of the report is not permitted without the written authorization of AGC. The test results presented in the report apply only to the tested sample. Any objections to report issued by AGC should be submitted to AGC within 15days after the issuance of the test report. Further enquiry of validity or verification of the test report should be addressed to AGC by agc01@agccert.com.

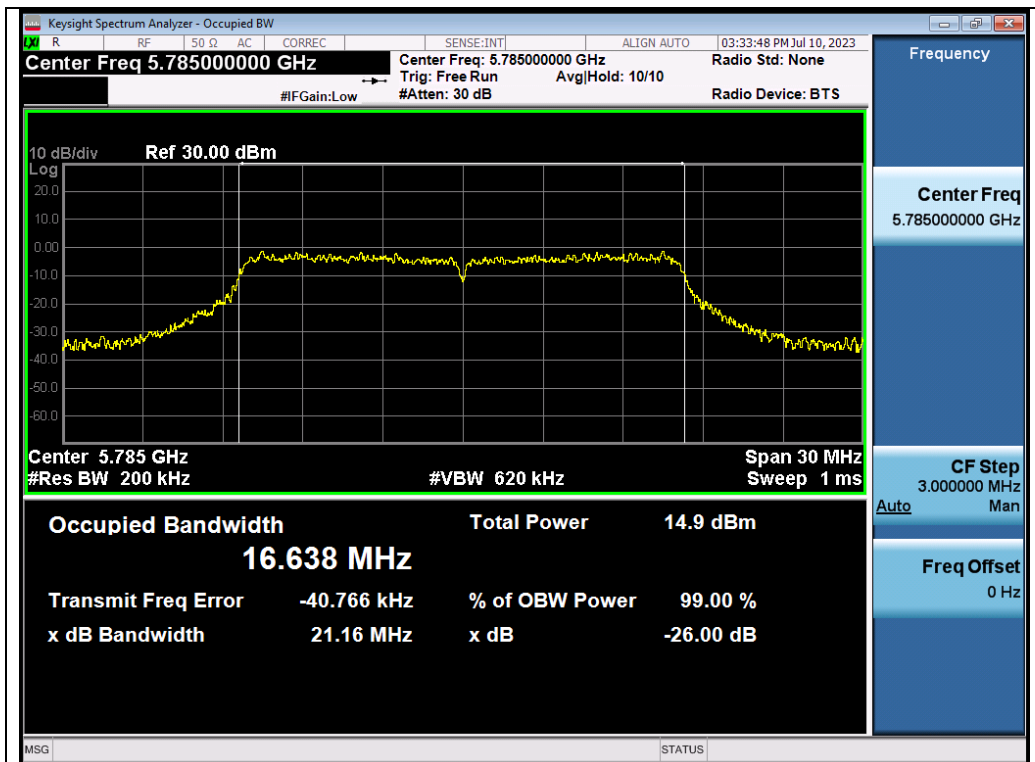

Test_Graph_802.11a_ANT1_5785_6Mbps_OBW

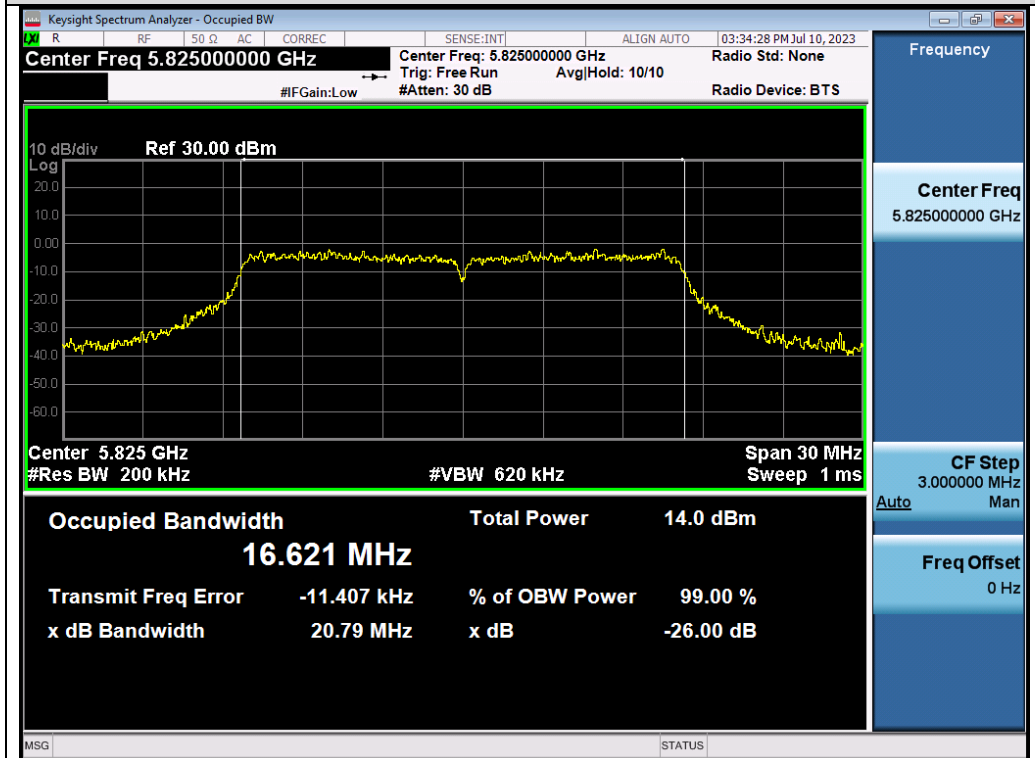

Test_Graph_802.11a_ANT1_5825_6Mbps_OBW

Any report having not been signed by authorized approver, or having been altered without authorization, or having not been stamped by the "Dedicated Testing/Inspection Stamp" is deemed to be invalid. Copying or excerpting portion of, or altering the content of the report is not permitted without the written authorization of AGC. The test results presented in the report apply only to the tested sample. Any objections to report issued by AGC should be submitted to AGC within 15days after the issuance of the test report. Further enquiry of validity or verification of the test report should be addressed to AGC by agc01@agccert.com.

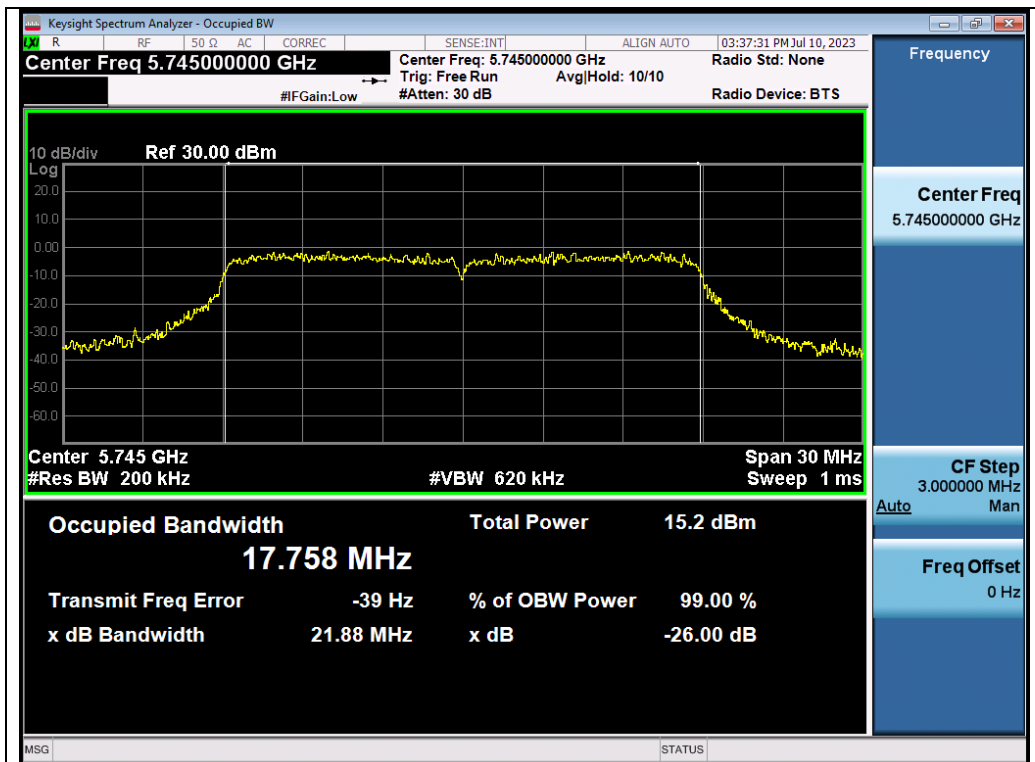

Test_Graph_802.11n20_ANT1_5745_MCS0_OBW

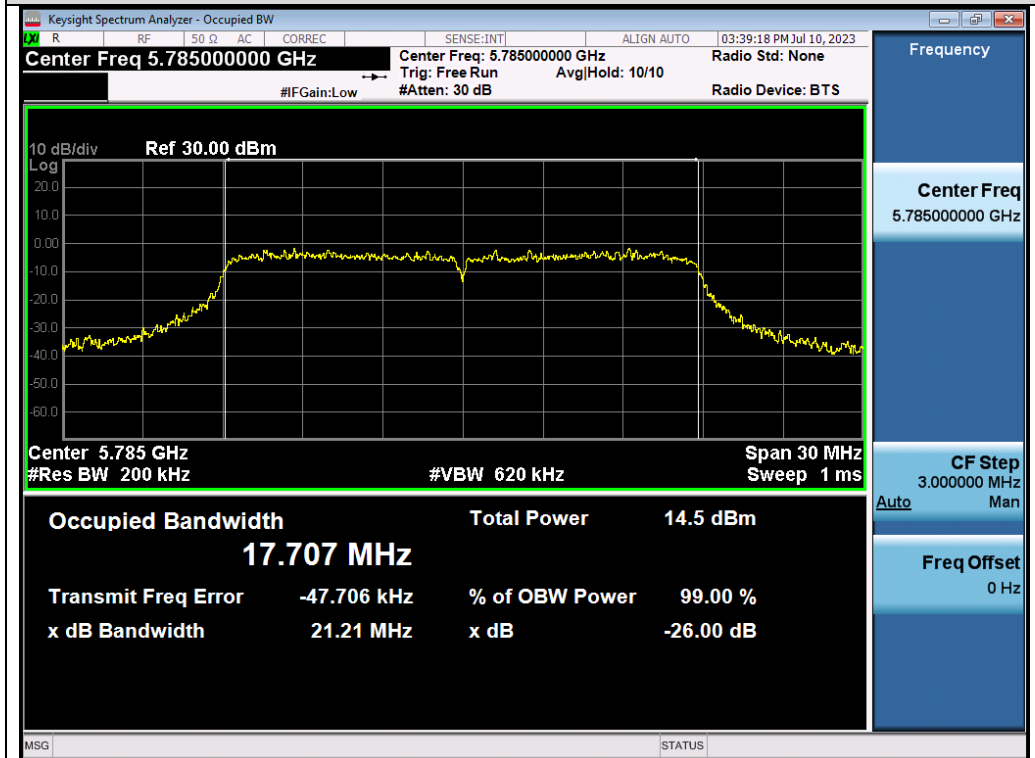

Test_Graph_802.11n20_ANT1_5785_MCS0_OBW

Any report having not been signed by authorized approver, or having been altered without authorization, or having not been stamped by the "Dedicated Testing/Inspection Stamp" is deemed to be invalid. Copying or excerpting portion of, or altering the content of the report is not permitted without the written authorization of AGC. The test results presented in the report apply only to the tested sample. Any objections to report issued by AGC should be submitted to AGC within 15days after the issuance of the test report. Further enquiry of validity or verification of the test report should be addressed to AGC by agc01@agccert.com.

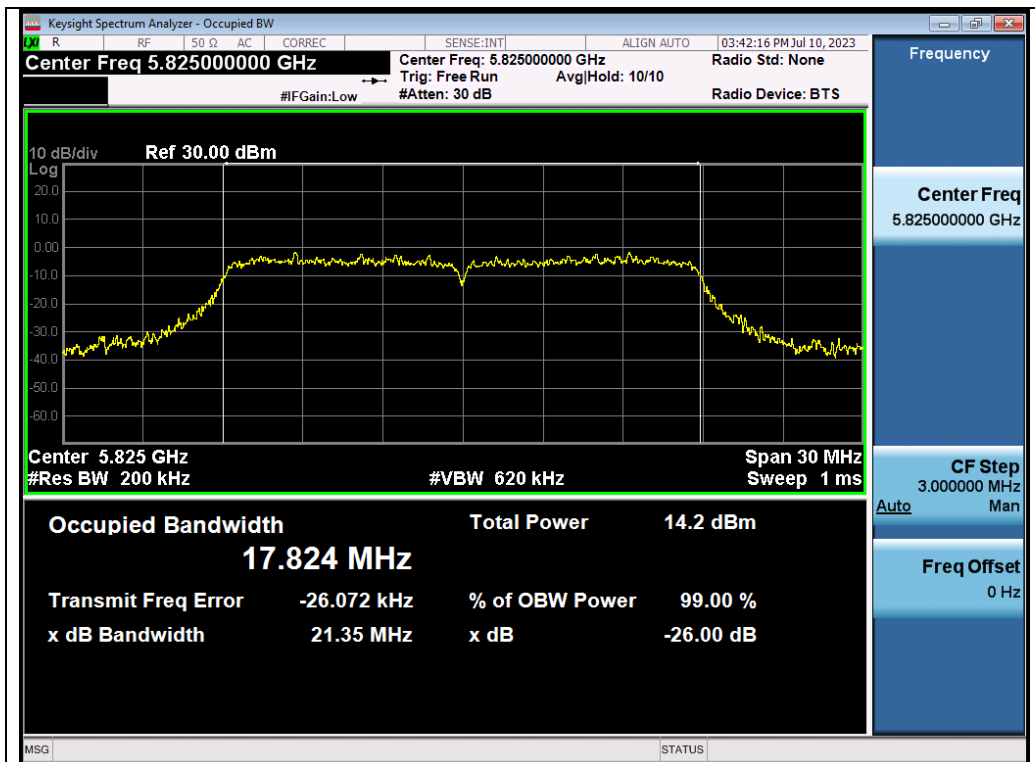

Test_Graph_802.11n20_ANT1_5825_MCS0_OBW

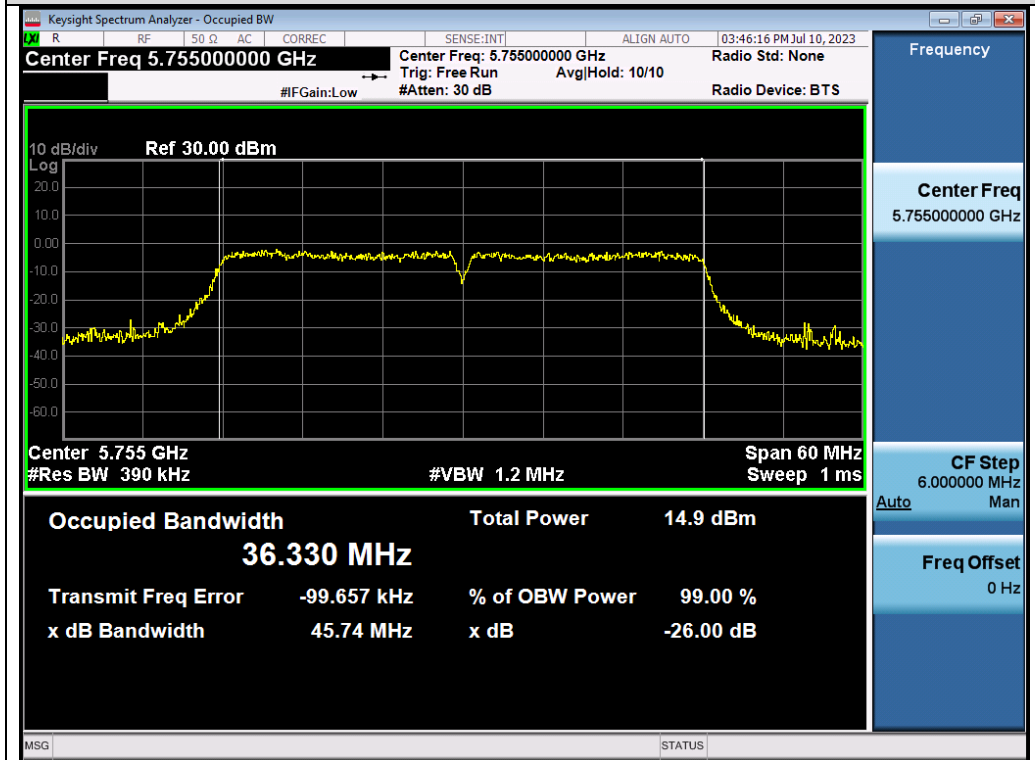

Test_Graph_802.11n40_ANT1_5755_MCS0_OBW

Any report having not been signed by authorized approver, or having been altered without authorization, or having not been stamped by the "Dedicated Testing/Inspection Stamp" is deemed to be invalid. Copying or excerpting portion of, or altering the content of the report is not permitted without the written authorization of AGC. The test results presented in the report apply only to the tested sample. Any objections to report issued by AGC should be submitted to AGC within 15days after the issuance of the test report. Further enquiry of validity or verification of the test report should be addressed to AGC by agc01@agccert.com.

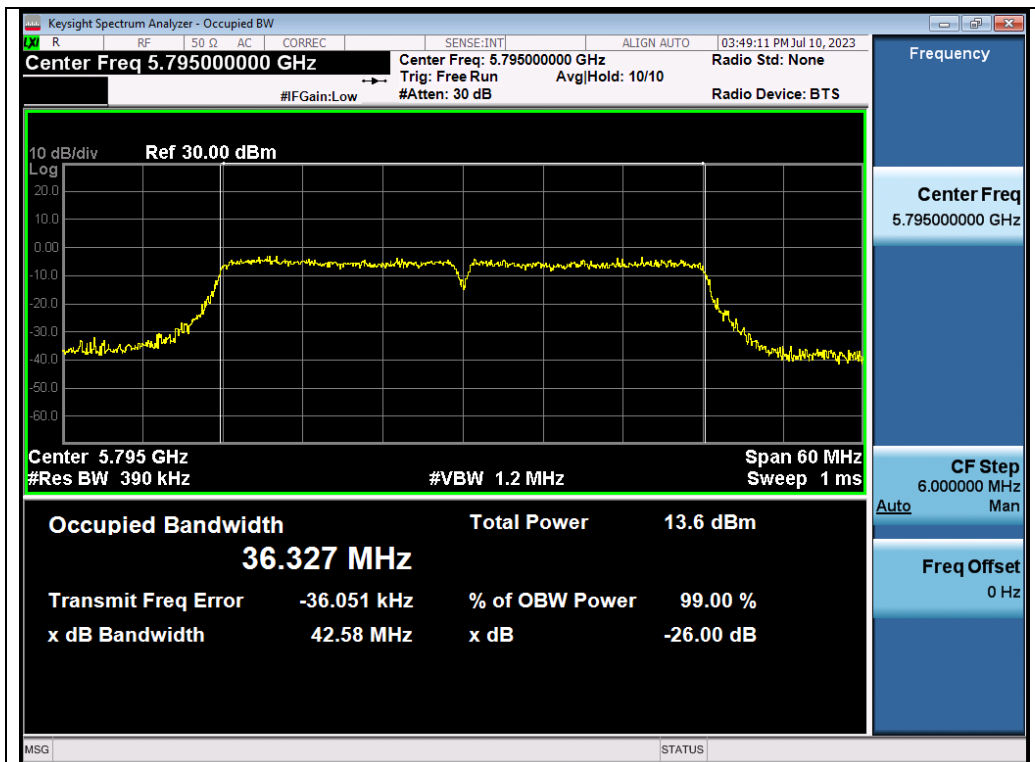

Test_Graph_802.11n40_ANT1_5795_MCS0_OBW

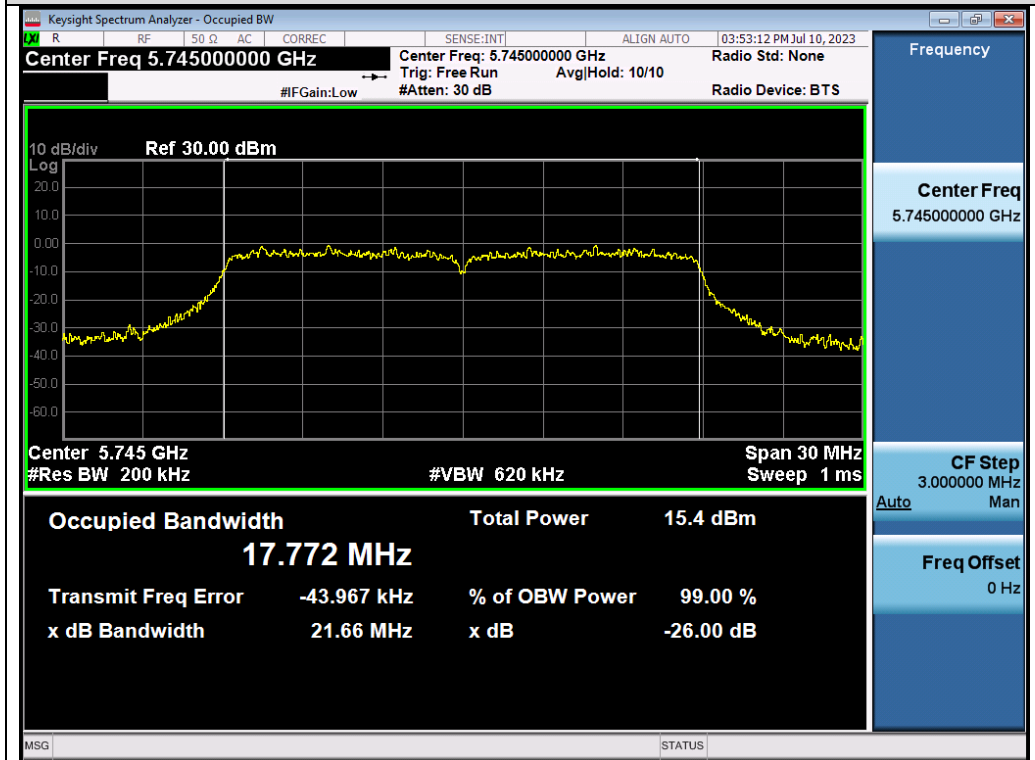

Test_Graph_802.11ac20_ANT1_5745_MCS0_OBW

Any report having not been signed by authorized approver, or having been altered without authorization, or having not been stamped by the "Dedicated Testing/Inspection Stamp" is deemed to be invalid. Copying or excerpting portion of, or altering the content of the report is not permitted without the written authorization of AGC. The test results presented in the report apply only to the tested sample. Any objections to report issued by AGC should be submitted to AGC within 15days after the issuance of the test report. Further enquiry of validity or verification of the test report should be addressed to AGC by agc01@agccert.com.

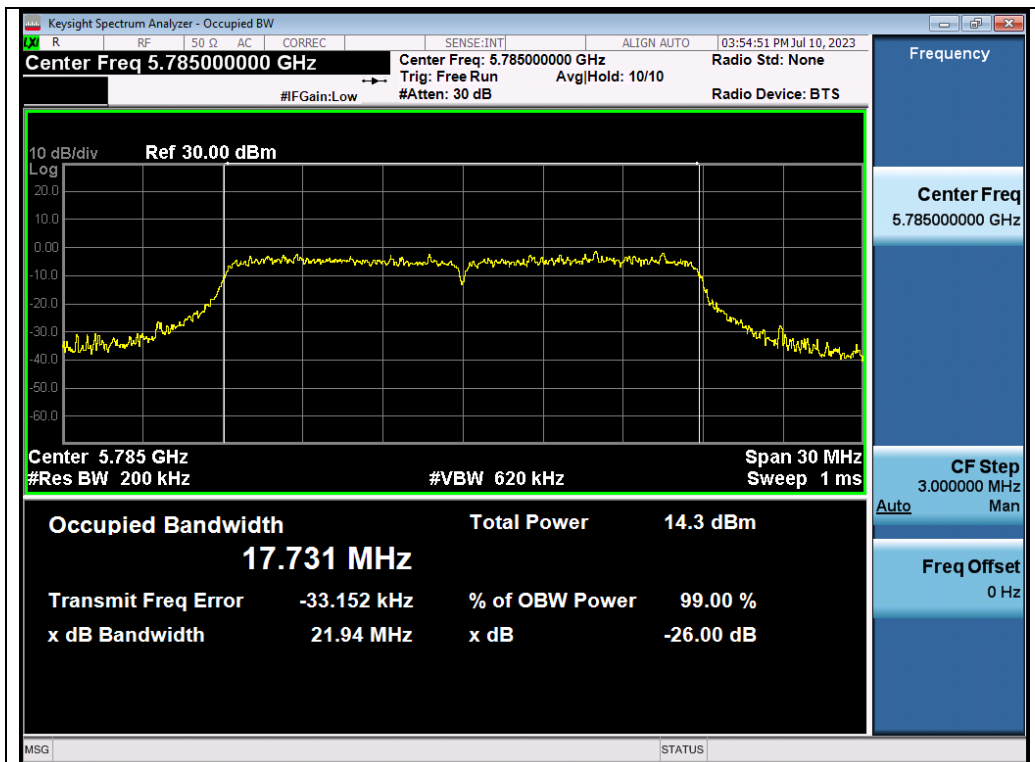

Test_Graph_802.11ac20_ANT1_5785_MCS0_OBW

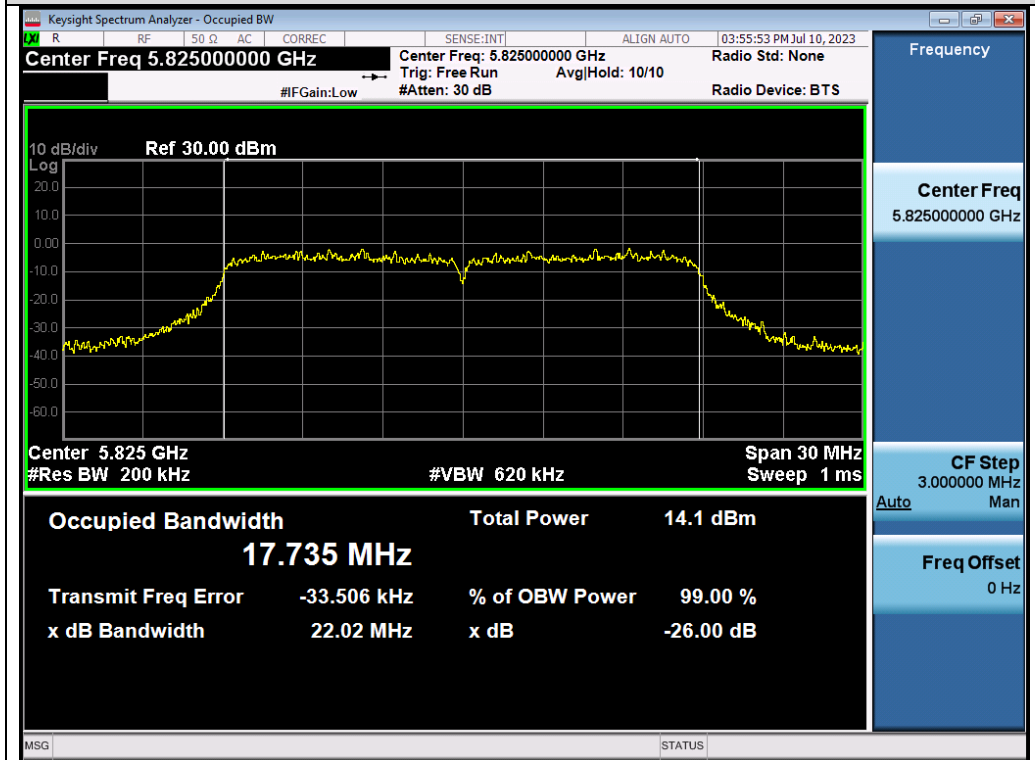

Test_Graph_802.11ac20_ANT1_5825_MCS9_OBW

Any report having not been signed by authorized approver, or having been altered without authorization, or having not been stamped by the "Dedicated Testing/Inspection Stamp" is deemed to be invalid. Copying or excerpting portion of, or altering the content of the report is not permitted without the written authorization of AGC. The test results presented in the report apply only to the tested sample. Any objections to report issued by AGC should be submitted to AGC within 15days after the issuance of the test report. Further enquiry of validity or verification of the test report should be addressed to AGC by agc01@agccert.com.

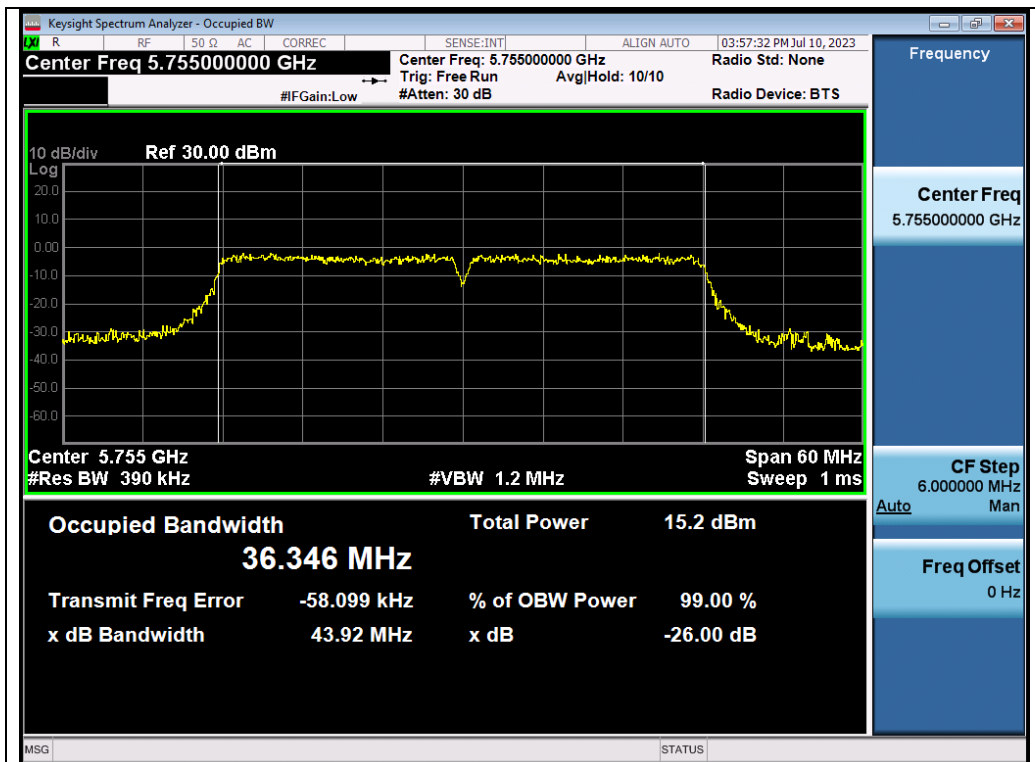

Test_Graph_802.11ac40_ANT1_5755_MCS9_OBW

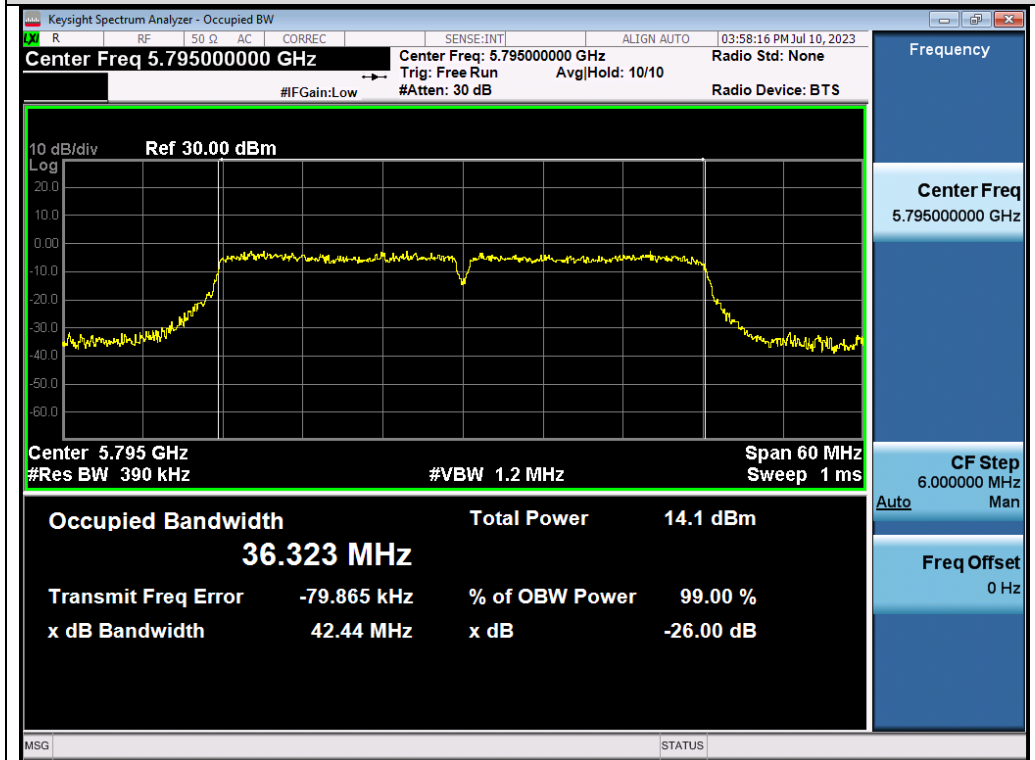

Test_Graph_802.11ac40_ANT1_5795_MCS9_OBW

Any report having not been signed by authorized approver, or having been altered without authorization, or having not been stamped by the "Dedicated Testing/Inspection Stamp" is deemed to be invalid. Copying or excerpting portion of, or altering the content of the report is not permitted without the written authorization of AGC. The test results presented in the report apply only to the tested sample. Any objections to report issued by AGC should be submitted to AGC within 15days after the issuance of the test report. Further enquiry of validity or verification of the test report should be addressed to AGC by agc01@agccert.com.

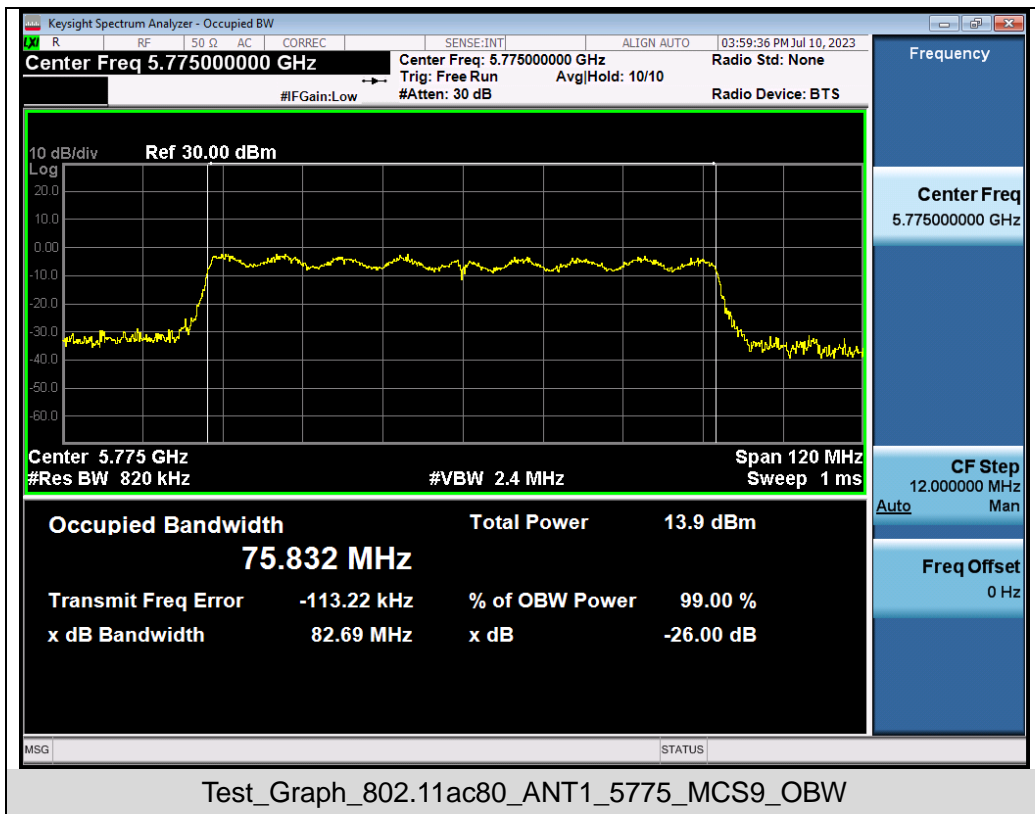

Test Graphs of DTS Bandwidth for band 5.725-5.85 GHz

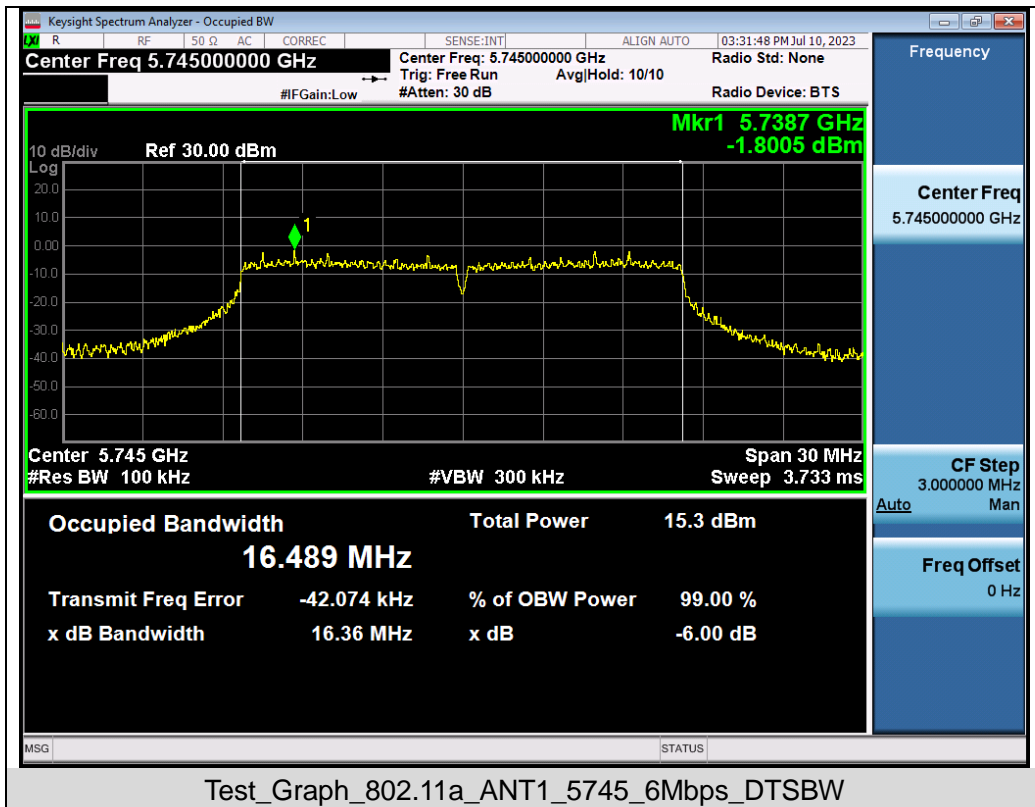

Any report having not been signed by authorized approver, or having been altered without authorization, or having not been stamped by the "Dedicated Testing/Inspection Stamp" is deemed to be invalid. Copying or excerpting portion of, or altering the content of the report is not permitted without the written authorization of AGC. The test results presented in the report apply only to the tested sample. Any objections to report issued by AGC should be submitted to AGC within 15days after the issuance of the test report. Further enquiry of validity or verification of the test report should be addressed to AGC by agc01@agccert.com.

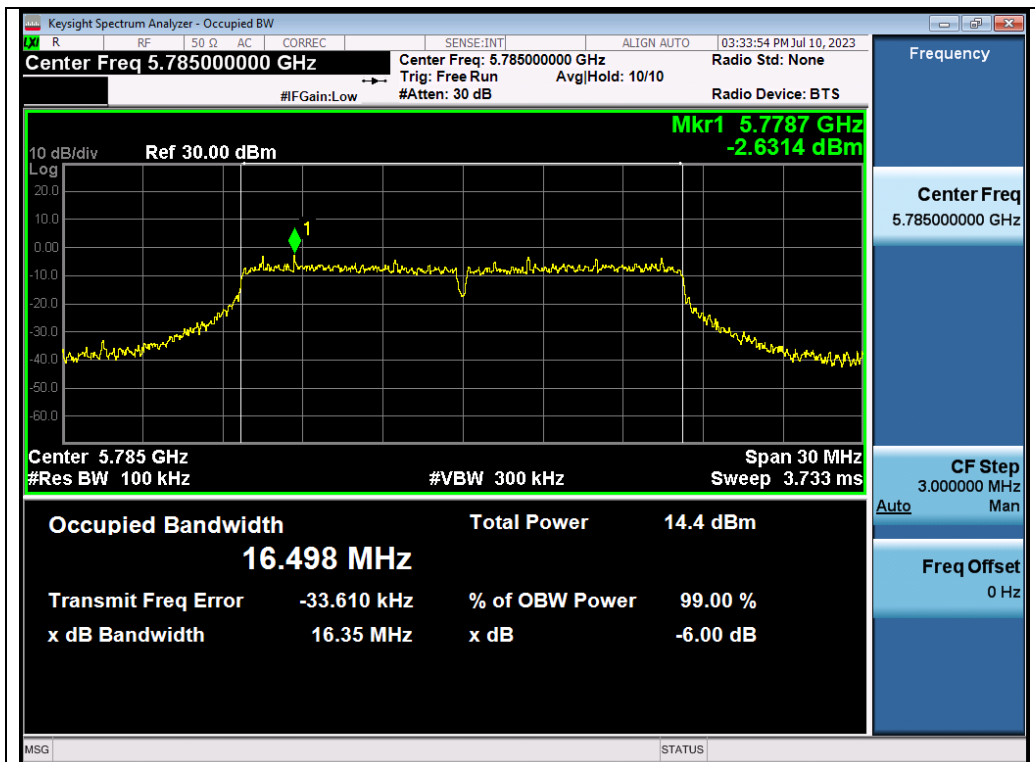

Test_Graph_802.11a_ANT1_5785_6Mbps_DTSBW

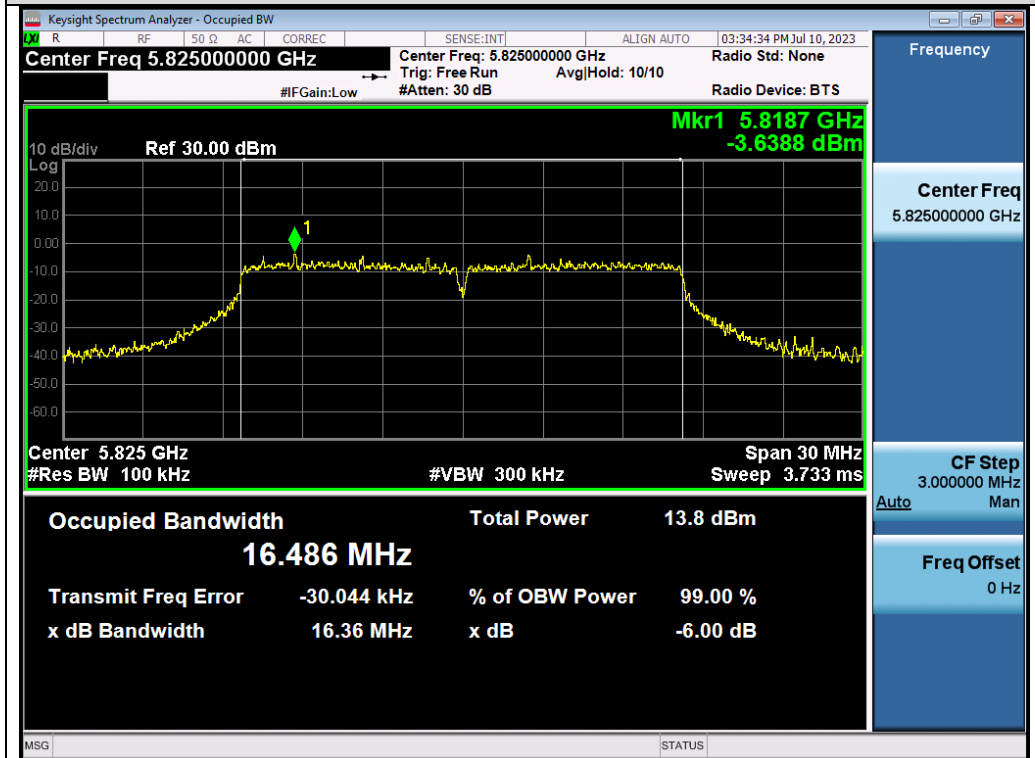

Test_Graph_802.11a_ANT1_5825_6Mbps_DTSBW

Any report having not been signed by authorized approver, or having been altered without authorization, or having not been stamped by the "Dedicated Testing/Inspection Stamp" is deemed to be invalid. Copying or excerpting portion of, or altering the content of the report is not permitted without the written authorization of AGC. The test results presented in the report apply only to the tested sample. Any objections to report issued by AGC should be submitted to AGC within 15days after the issuance of the test report. Further enquiry of validity or verification of the test report should be addressed to AGC by agc01@agccert.com.

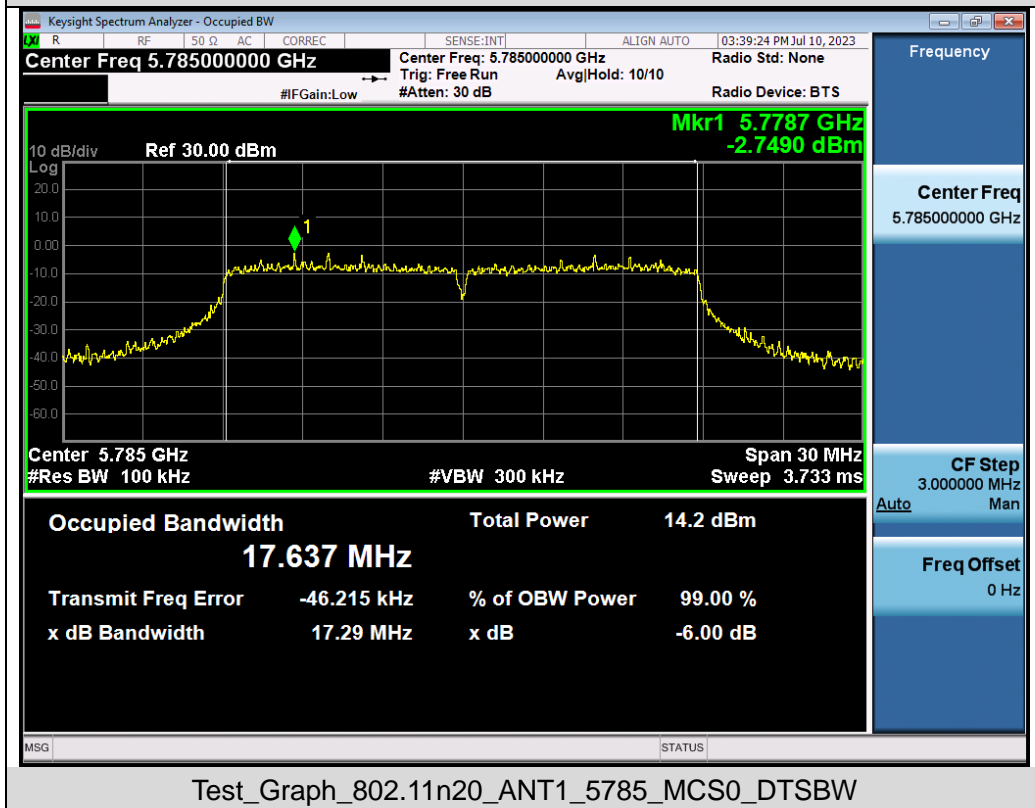
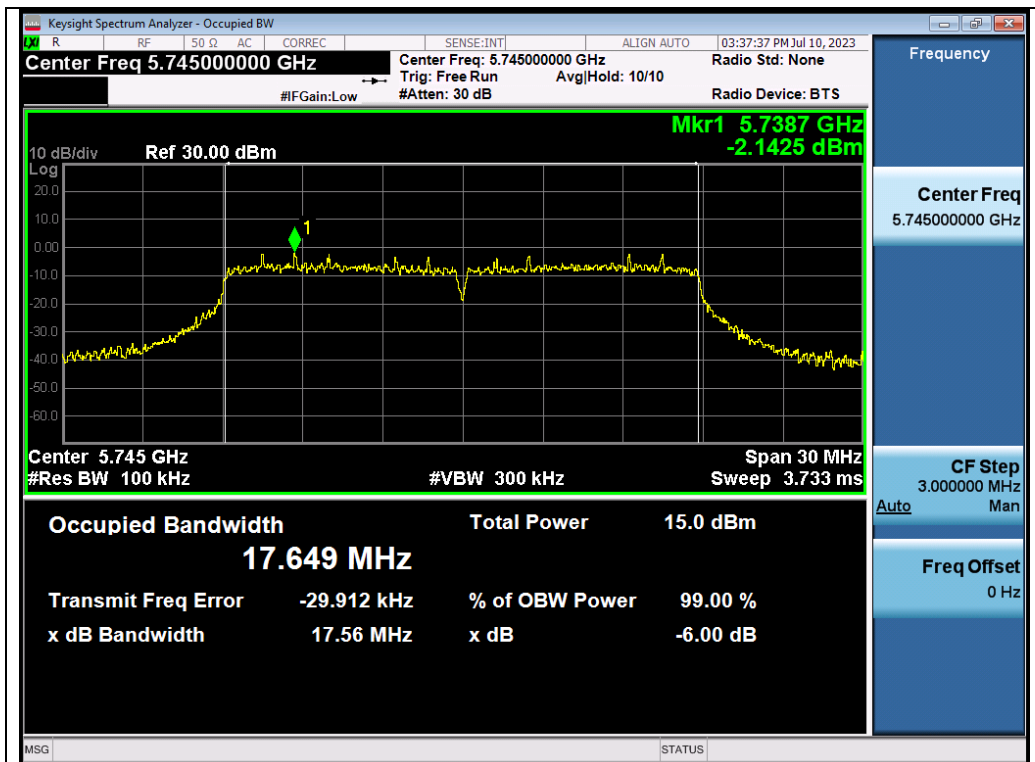

Any report having not been signed by authorized approver, or having been altered without authorization, or having not been stamped by the "Dedicated Testing/Inspection Stamp" is deemed to be invalid. Copying or excerpting portion of, or altering the content of the report is not permitted without the written authorization of AGC. The test results presented in the report apply only to the tested sample. Any objections to report issued by AGC should be submitted to AGC within 15days after the issuance of the test report. Further enquiry of validity or verification of the test report should be addressed to AGC by agc01@agccert.com.

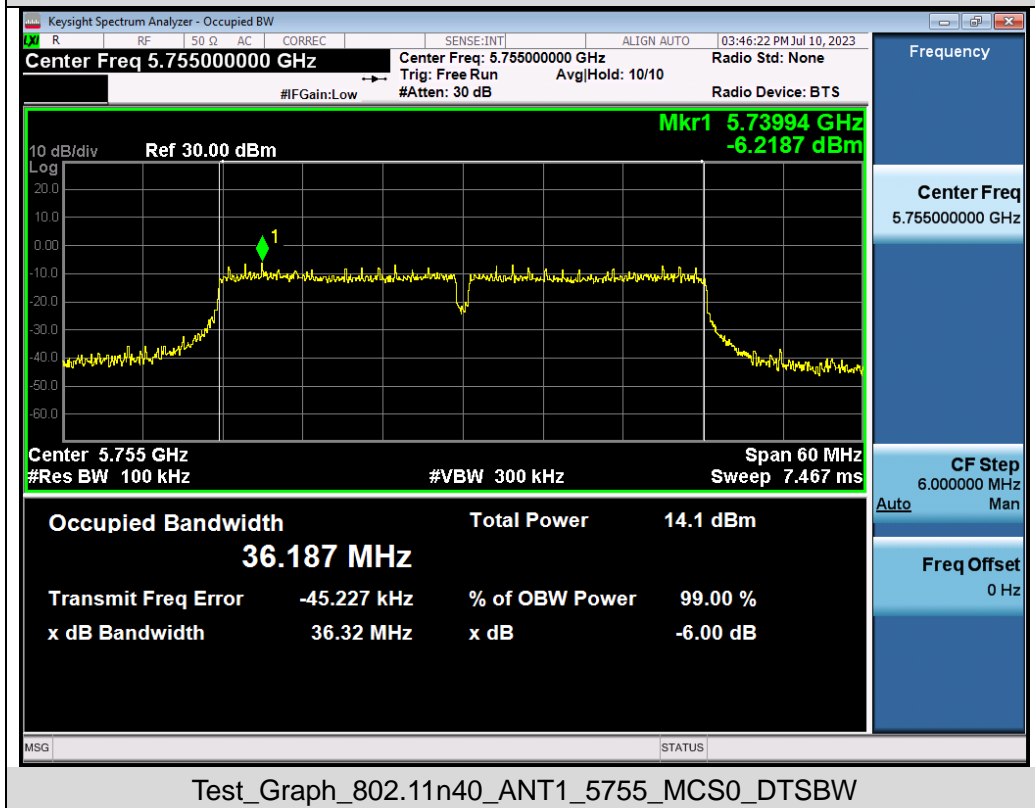
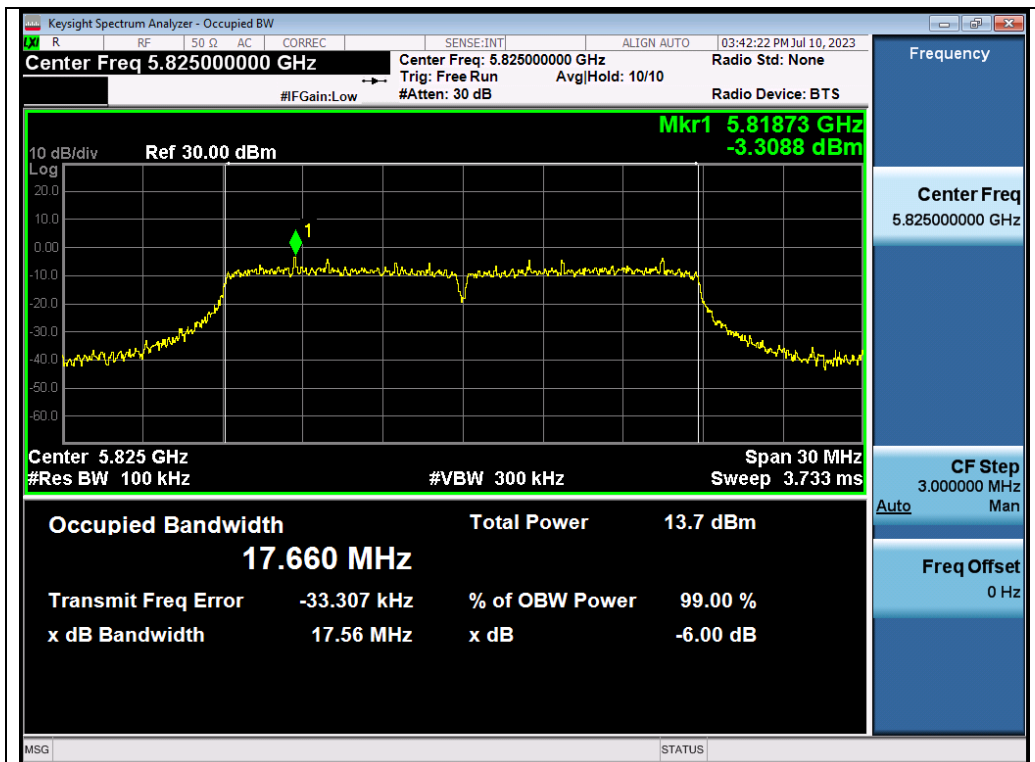

Any report having not been signed by authorized approver, or having been altered without authorization, or having not been stamped by the "Dedicated Testing/Inspection Stamp" is deemed to be invalid. Copying or excerpting portion of, or altering the content of the report is not permitted without the written authorization of AGC. The test results presented in the report apply only to the tested sample. Any objections to report issued by AGC should be submitted to AGC within 15days after the issuance of the test report. Further enquiry of validity or verification of the test report should be addressed to AGC by agc01@agccert.com.

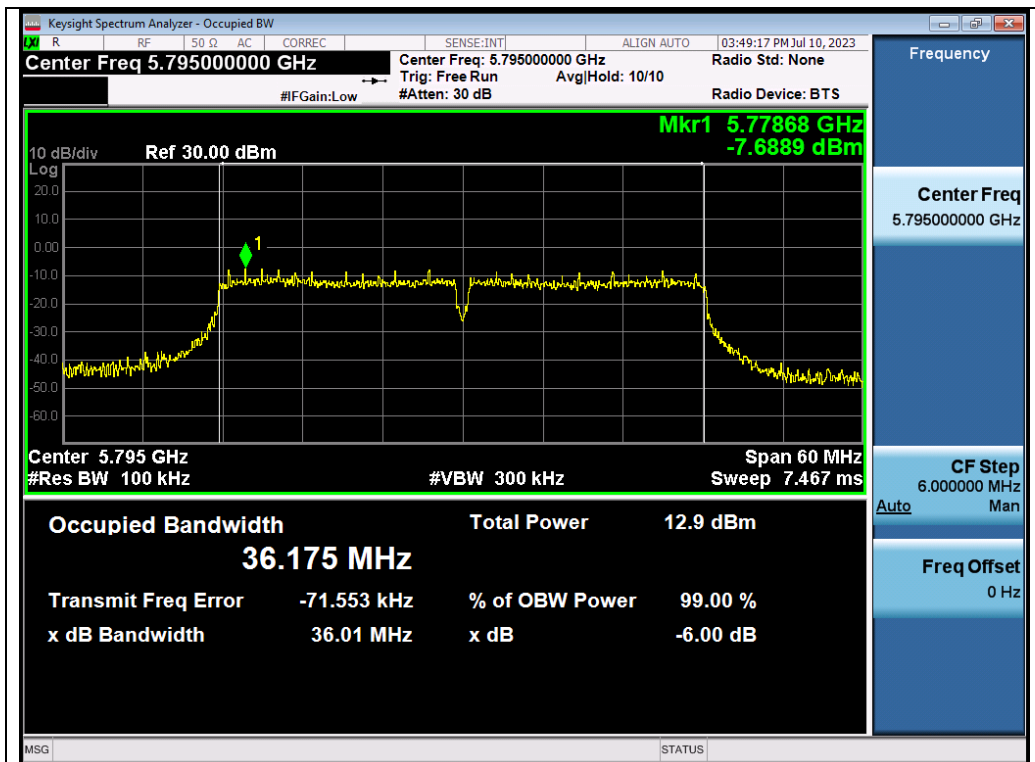

Test_Graph_802.11n40_ANT1_5795_MCS0_DTSBW

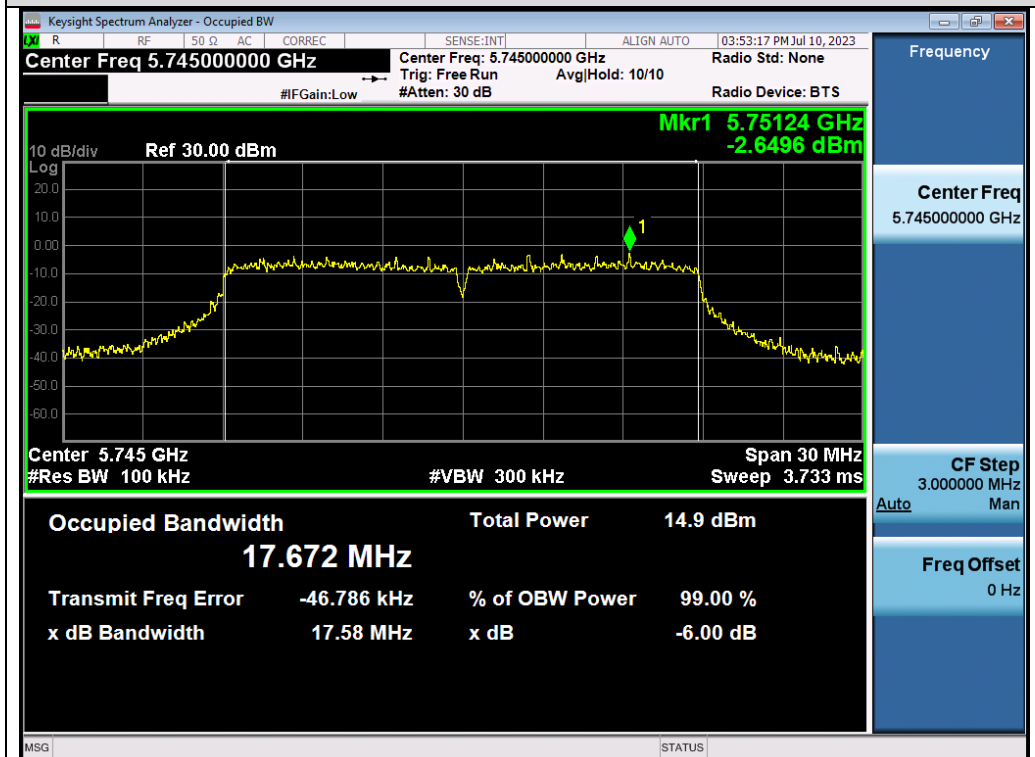

Test_Graph_802.11ac20_ANT1_5745_MCS0_DTSBW

Any report having not been signed by authorized approver, or having been altered without authorization, or having not been stamped by the "Dedicated Testing/Inspection Stamp" is deemed to be invalid. Copying or excerpting portion of, or altering the content of the report is not permitted without the written authorization of AGC. The test results presented in the report apply only to the tested sample. Any objections to report issued by AGC should be submitted to AGC within 15days after the issuance of the test report. Further enquiry of validity or verification of the test report should be addressed to AGC by agc01@agccert.com.

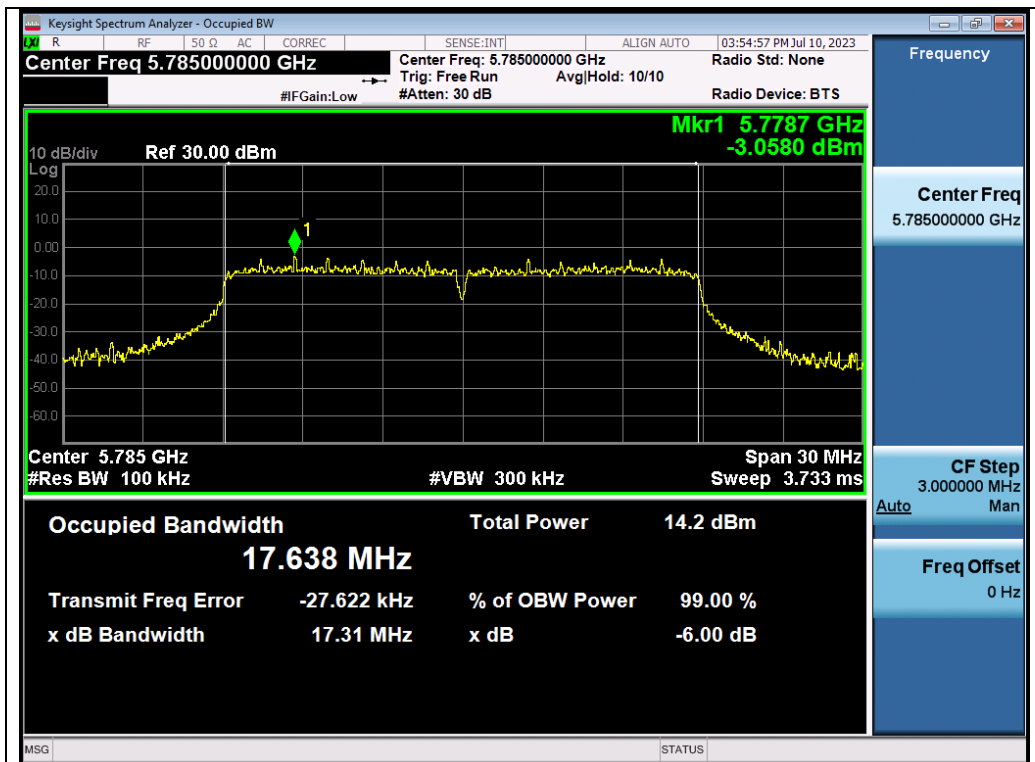

Test_Graph_802.11ac20_ANT1_5785_MCS0_DTSBW

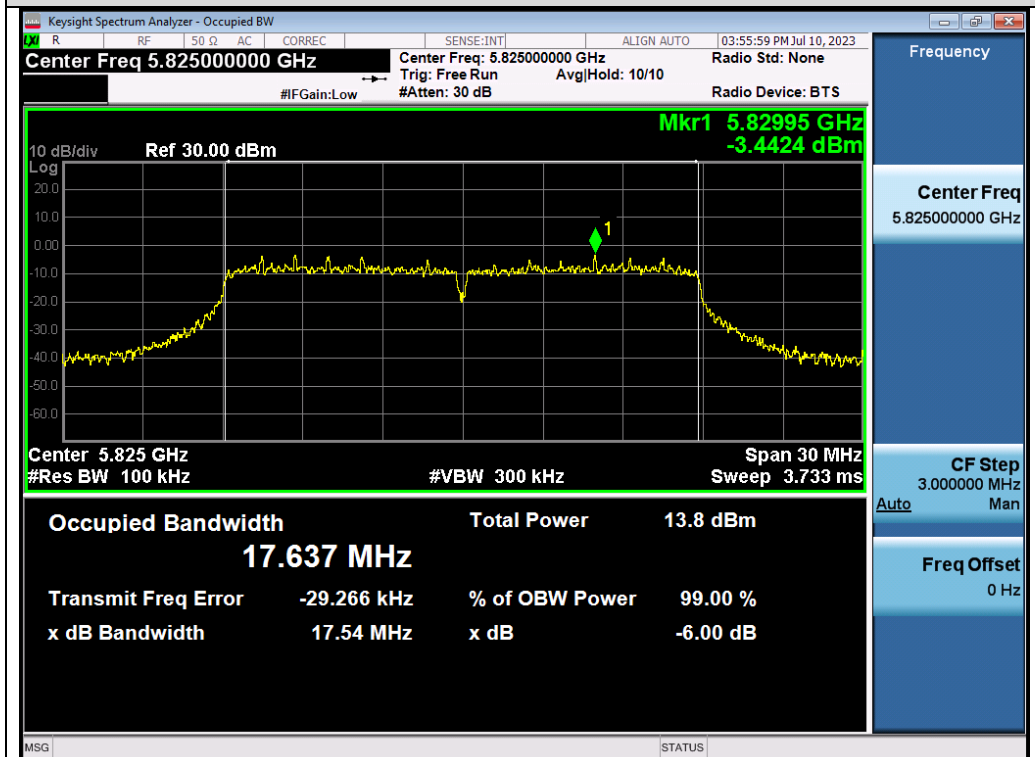

Test_Graph_802.11ac20_ANT1_5825_MCS9_DTSBW

Any report having not been signed by authorized approver, or having been altered without authorization, or having not been stamped by the "Dedicated Testing/Inspection Stamp" is deemed to be invalid. Copying or excerpting portion of, or altering the content of the report is not permitted without the written authorization of AGC. The test results presented in the report apply only to the tested sample. Any objections to report issued by AGC should be submitted to AGC within 15days after the issuance of the test report. Further enquiry of validity or verification of the test report should be addressed to AGC by agc01@agccert.com.

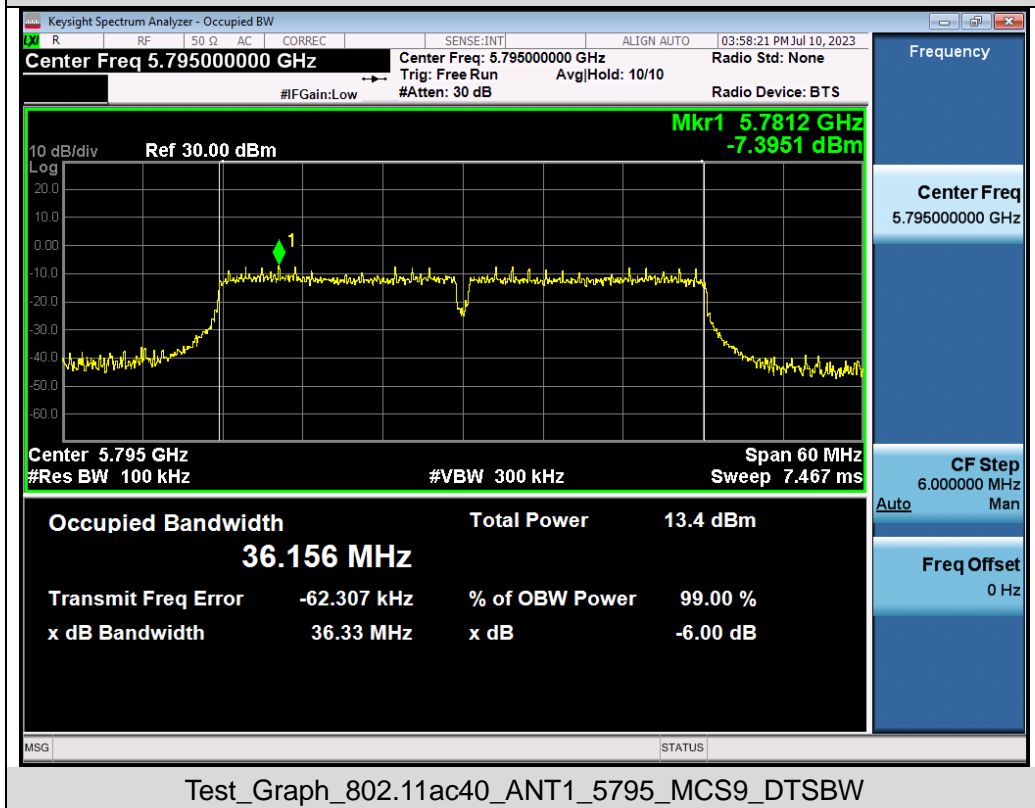
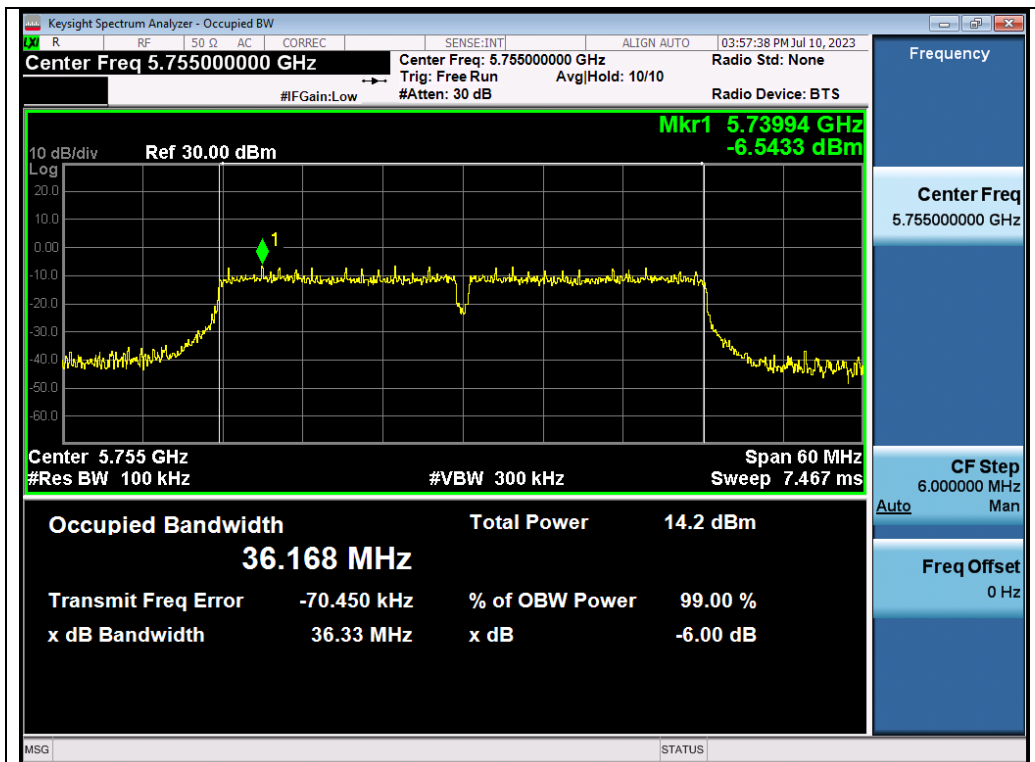

Any report having not been signed by authorized approver, or having been altered without authorization, or having not been stamped by the "Dedicated Testing/Inspection Stamp" is deemed to be invalid. Copying or excerpting portion of, or altering the content of the report is not permitted without the written authorization of AGC. The test results presented in the report apply only to the tested sample. Any objections to report issued by AGC should be submitted to AGC within 15days after the issuance of the test report. Further enquiry of validity or verification of the test report should be addressed to AGC by agc01@agccert.com.

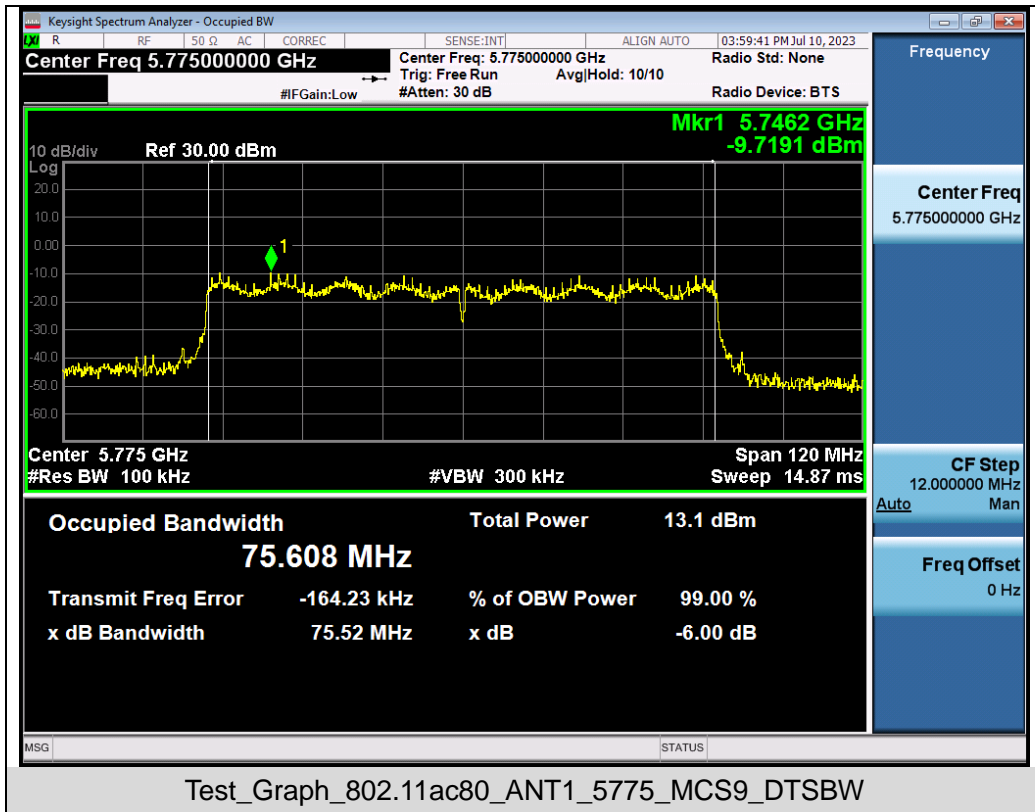

Any report having not been signed by authorized approver, or having been altered without authorization, or having not been stamped by the "Dedicated Testing/Inspection Stamp" is deemed to be invalid. Copying or excerpting portion of, or altering the content of the report is not permitted without the written authorization of AGC. The test results presented in the report apply only to the tested sample. Any objections to report issued by AGC should be submitted to AGC within 15days after the issuance of the test report. Further enquiry of validity or verification of the test report should be addressed to AGC by agc01@agccert.com.

Attestation of Global Compliance(Shenzhen)Co., Ltd
Attestation of Global Compliance(Shenzhen)Std & Tech Co., Ltd
Tel: +86-755 2523 4088 E-mail: agc@agccert.com Web: http://www.agccert.com/

8. POWER SPECTRAL DENSITY MEASUREMENT

8.1 MEASUREMENT LIMITS

Operation Band	EUT Category		LIMIT
U-NII-1	<input type="checkbox"/>	Outdoor Access Point	17dBm/ MHz
	<input type="checkbox"/>	Fixed point-to-point Access Point	17dBm/ MHz
	<input type="checkbox"/>	Indoor Access Point	17dBm/ MHz
	<input checked="" type="checkbox"/>	Client devices	11dBm/ MHz
U-NII-2A	/		11dBm/ MHz
U-NII-2C	/		11dBm/ MHz
U-NII-3	/		30 dBm/500kHz

8.2 MEASUREMENT PROCEDURE

For Average power spectral density test:

1. Connect EUT RF output port to the Spectrum Analyzer through an RF attenuator.
2. Span was set to encompass the entire 26dB EBW of the signal.
3. RBW = 1MHz.
4. If measurement bandwidth of Maximum PSD is specified in 500 kHz, RBW = 100KHz
5. Set VBW \geq [3 \times RBW].
6. Sweep Time=Auto couple.
7. Detector function=RMS (i.e., power averaging).
8. Trace average at least 100 traces in power averaging (rms) mode.
9. When the measurement bandwidth of Maximum PSD is specified in 100 kHz, add a constant factor $10 \times \log(500\text{kHz}/100\text{kHz}) = 6.99$ dB to the measured result.
10. Determine according to the duty cycle of the equipment: when it is less than 98%, follow the steps below.
11. Add [10 log (1/D)], where D is the duty cycle, to the measured power to compute the average power during the actual transmission times (because the measurement represents an average over both the ON and OFF times of the transmission). For example, add [10 log (1/0.25)] = 6 dB if the duty cycle is 25%.
12. Record the test results in the report.

8.3 MEASUREMENT SETUP (BLOCK DIAGRAM OF CONFIGURATION)

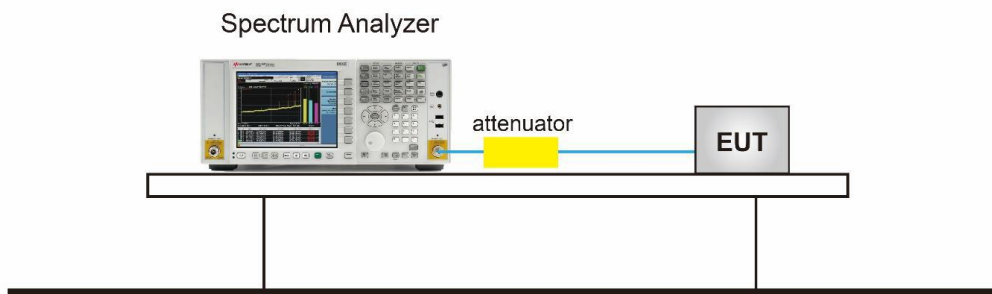

Any report having not been signed by authorized approver, or having been altered without authorization, or having not been stamped by the "Dedicated Testing/Inspection Stamp" is deemed to be invalid. Copying or excerpting portion of, or altering the content of the report is not permitted without the written authorization of AGC. The test results presented in the report apply only to the tested sample. Any objections to report issued by AGC should be submitted to AGC within 15days after the issuance of the test report. Further enquiry of validity or verification of the test report should be addressed to AGC by agc01@agccert.com.

8.4 MEASUREMENT RESULT

Test Data of Conducted Output Power Density for band 5.15-5.25 GHz				
Test Mode	Test Channel (MHz)	Average Power Density (dBm/MHz)	Limits (dBm/MHz)	Pass or Fail
802.11a	5180	-0.532	11	Pass
	5200	-0.336	11	Pass
	5240	0.420	11	Pass
802.11n20	5180	-1.219	11	Pass
	5200	-0.801	11	Pass
	5240	-0.234	11	Pass
802.11n40	5190	-3.603	11	Pass
	5230	-3.578	11	Pass
802.11ac20	5180	-1.515	11	Pass
	5200	-0.803	11	Pass
	5240	-0.163	11	Pass
802.11ac40	5190	-3.528	11	Pass
	5230	-3.108	11	Pass
802.11ac80	5210	-5.324	11	Pass

Any report having not been signed by authorized approver, or having been altered without authorization, or having not been stamped by the "Dedicated Testing/Inspection Stamp" is deemed to be invalid. Copying or excerpting portion of, or altering the content of the report is not permitted without the written authorization of AGC. The test results presented in the report apply only to the tested sample. Any objections to report issued by AGC should be submitted to AGC within 15days after the issuance of the test report. Further enquiry of validity or verification of the test report should be addressed to AGC by agc01@agccert.com.

Test Data of Conducted Output Power Density for band 5.25-5.35 GHz				
Test Mode	Test Channel (MHz)	Average Power Density (dBm/MHz)	Limits (dBm/MHz)	Pass or Fail
802.11a	5260	-1.331	11	Pass
	5300	-0.728	11	Pass
	5320	-0.990	11	Pass
802.11n20	5260	-2.421	11	Pass
	5300	-1.938	11	Pass
	5320	-1.954	11	Pass
802.11n40	5270	-6.516	11	Pass
	5310	-5.933	11	Pass
802.11ac20	5260	-2.937	11	Pass
	5300	-2.116	11	Pass
	5320	-2.023	11	Pass
802.11ac40	5270	-5.099	11	Pass
	5310	-5.287	11	Pass
802.11ac80	5290	-6.665	11	Pass

Any report having not been signed by authorized approver, or having been altered without authorization, or having not been stamped by the "Dedicated Testing/Inspection Stamp" is deemed to be invalid. Copying or excerpting portion of, or altering the content of the report is not permitted without the written authorization of AGC. The test results presented in the report apply only to the tested sample. Any objections to report issued by AGC should be submitted to AGC within 15days after the issuance of the test report. Further enquiry of validity or verification of the test report should be addressed to AGC by agc01@agccert.com.

Test Data of Conducted Output Power Density for band 5.470-5.725 GHz				
Test Mode	Test Channel (MHz)	Average Power Density (dBm/MHz)	Limits (dBm/MHz)	Pass or Fail
802.11a	5500	-1.856	11	Pass
	5600	-0.055	11	Pass
	5700	-1.121	11	Pass
802.11n20	5500	-2.706	11	Pass
	5600	-0.986	11	Pass
	5700	-1.712	11	Pass
802.11n40	5510	-4.659	11	Pass
	5590	-3.309	11	Pass
	5670	-3.668	11	Pass
802.11ac20	5500	-2.670	11	Pass
	5600	-0.969	11	Pass
	5700	-1.823	11	Pass
802.11ac40	5510	-5.198	11	Pass
	5590	-3.647	11	Pass
	5670	-3.829	11	Pass
802.11ac80	5530	-6.347	11	Pass
	5610	-5.818	11	Pass

Any report having not been signed by authorized approver, or having been altered without authorization, or having not been stamped by the "Dedicated Testing/Inspection Stamp" is deemed to be invalid. Copying or excerpting portion of, or altering the content of the report is not permitted without the written authorization of AGC. The test results presented in the report apply only to the tested sample. Any objections to report issued by AGC should be submitted to AGC within 15days after the issuance of the test report. Further enquiry of validity or verification of the test report should be addressed to AGC by agc01@agccert.com.

Test Data of Conducted Output Power Density for band 5.725-5.85 GHz					
Test Mode	Test Channel (MHz)	Average Power Density (dBm/100kHz)	Average Power Density (dBm/500kHz)	Limits (dBm/500kHz)	Pass or Fail
802.11a	5745	-9.488	-2.498	30	Pass
	5785	-10.337	-3.347	30	Pass
	5825	-10.469	-3.479	30	Pass
802.11n20	5745	-9.753	-2.763	30	Pass
	5785	-10.513	-3.523	30	Pass
	5825	-11.25	-4.260	30	Pass
802.11n40	5755	-12.953	-5.963	30	Pass
	5795	-14.982	-7.992	30	Pass
802.11ac20	5745	-10.114	-3.124	30	Pass
	5785	-10.64	-3.650	30	Pass
	5825	-11.509	-4.519	30	Pass
802.11ac40	5755	-13.251	-6.261	30	Pass
	5795	-13.782	-6.792	30	Pass
802.11ac80	5775	-15.159	-8.169	30	Pass

Any report having not been signed by authorized approver, or having been altered without authorization, or having not been stamped by the "Dedicated Testing/Inspection Stamp" is deemed to be invalid. Copying or excerpting portion of, or altering the content of the report is not permitted without the written authorization of AGC. The test results presented in the report apply only to the tested sample. Any objections to report issued by AGC should be submitted to AGC within 15days after the issuance of the test report. Further enquiry of validity or verification of the test report should be addressed to AGC by agc01@agccert.com.

Test Graphs of Conducted Output Power Spectral Density for band 5.15-5.25 GHz



Test_Graph_802.11a_ANT1_5180_6Mbps_PSD

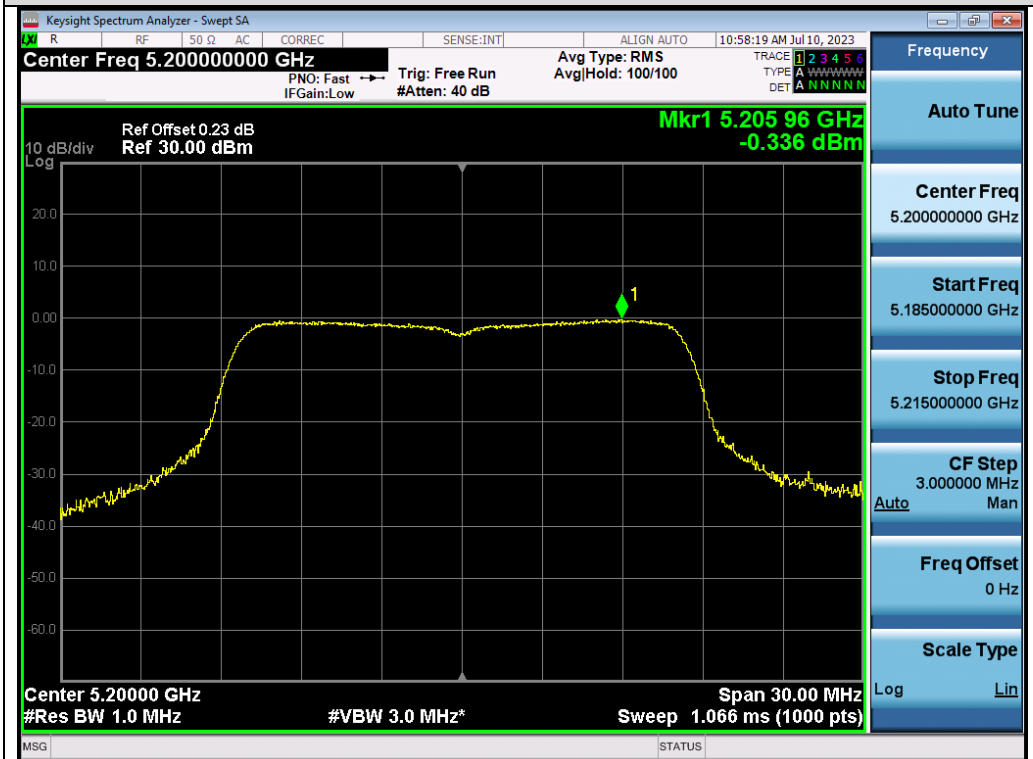

Test_Graph_802.11a_ANT1_5200_6Mbps_PSD

Any report having not been signed by authorized approver, or having been altered without authorization, or having not been stamped by the "Dedicated Testing/Inspection Stamp" is deemed to be invalid. Copying or excerpting portion of, or altering the content of the report is not permitted without the written authorization of AGC. The test results presented in the report apply only to the tested sample. Any objections to report issued by AGC should be submitted to AGC within 15days after the issuance of the test report. Further enquiry of validity or verification of the test report should be addressed to AGC by agc01@agccert.com.



Test_Graph_802.11a_ANT1_5240_6Mbps_PSD

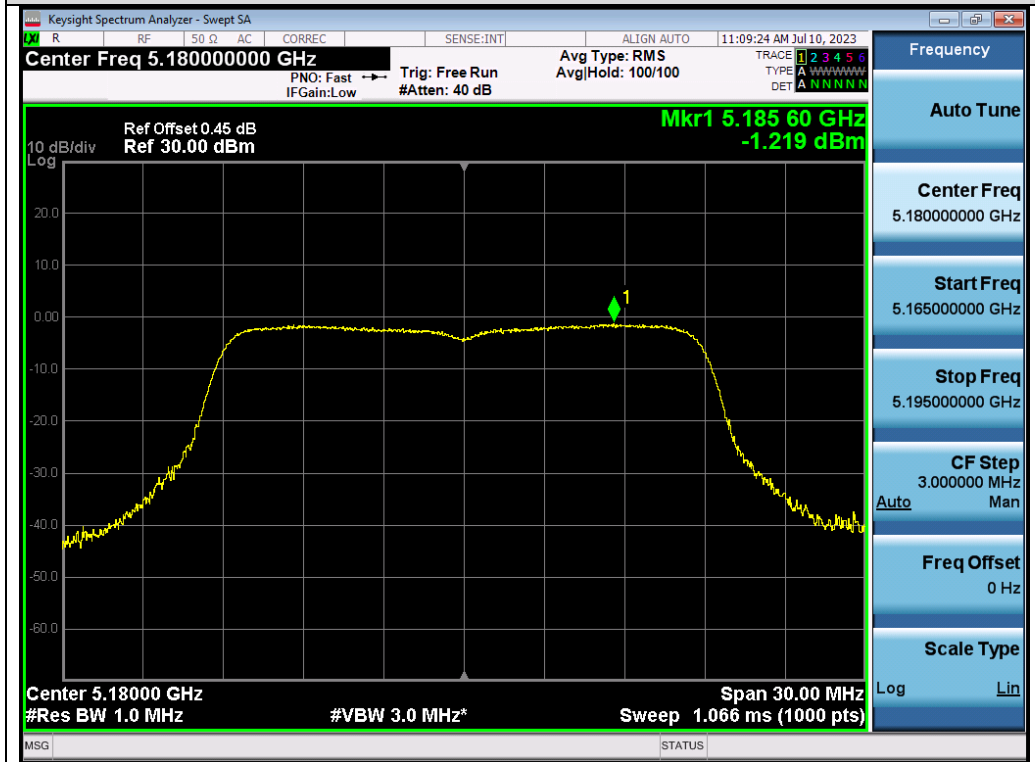

Test_Graph_802.11n20_ANT1_5180_MCS0_PSD

Any report having not been signed by authorized approver, or having been altered without authorization, or having not been stamped by the "Dedicated Testing/Inspection Stamp" is deemed to be invalid. Copying or excerpting portion of, or altering the content of the report is not permitted without the written authorization of AGC. The test results presented in the report apply only to the tested sample. Any objections to report issued by AGC should be submitted to AGC within 15days after the issuance of the test report. Further enquiry of validity or verification of the test report should be addressed to AGC by agc01@agccert.com.

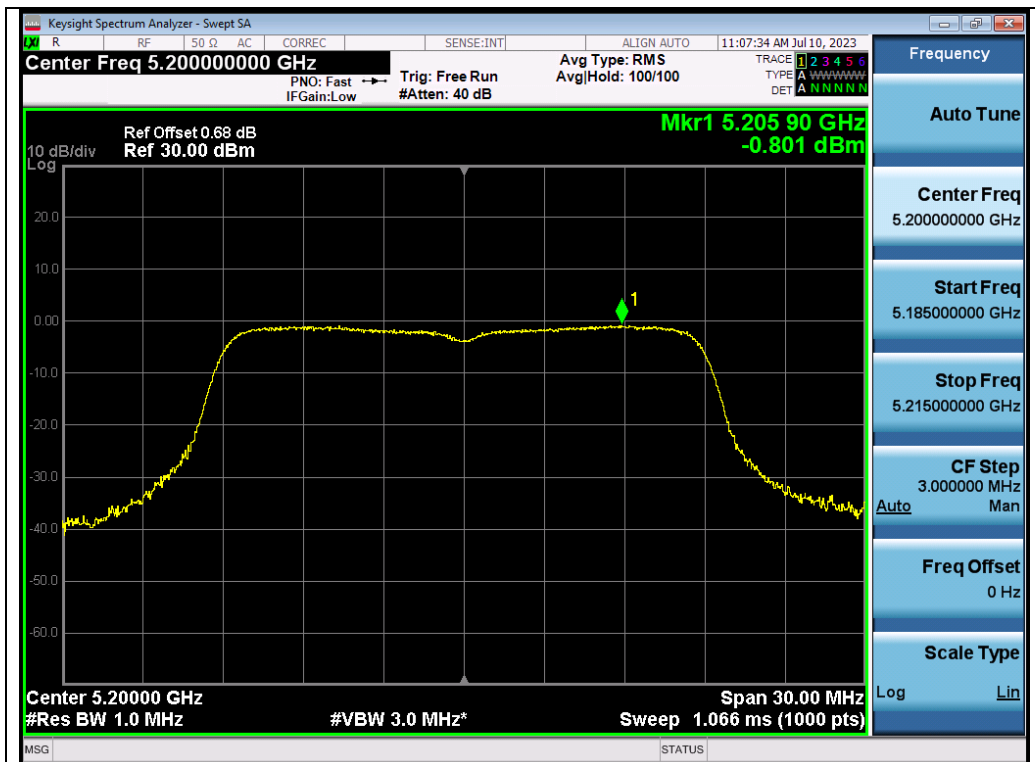

Test_Graph_802.11n20_ANT1_5200_MCS0_PSD



Test_Graph_802.11n20_ANT1_5240_MCS0_PSD

Any report having not been signed by authorized approver, or having been altered without authorization, or having not been stamped by the "Dedicated Testing/Inspection Stamp" is deemed to be invalid. Copying or excerpting portion of, or altering the content of the report is not permitted without the written authorization of AGC. The test results presented in the report apply only to the tested sample. Any objections to report issued by AGC should be submitted to AGC within 15days after the issuance of the test report. Further enquiry of validity or verification of the test report should be addressed to AGC by agc01@agccert.com.

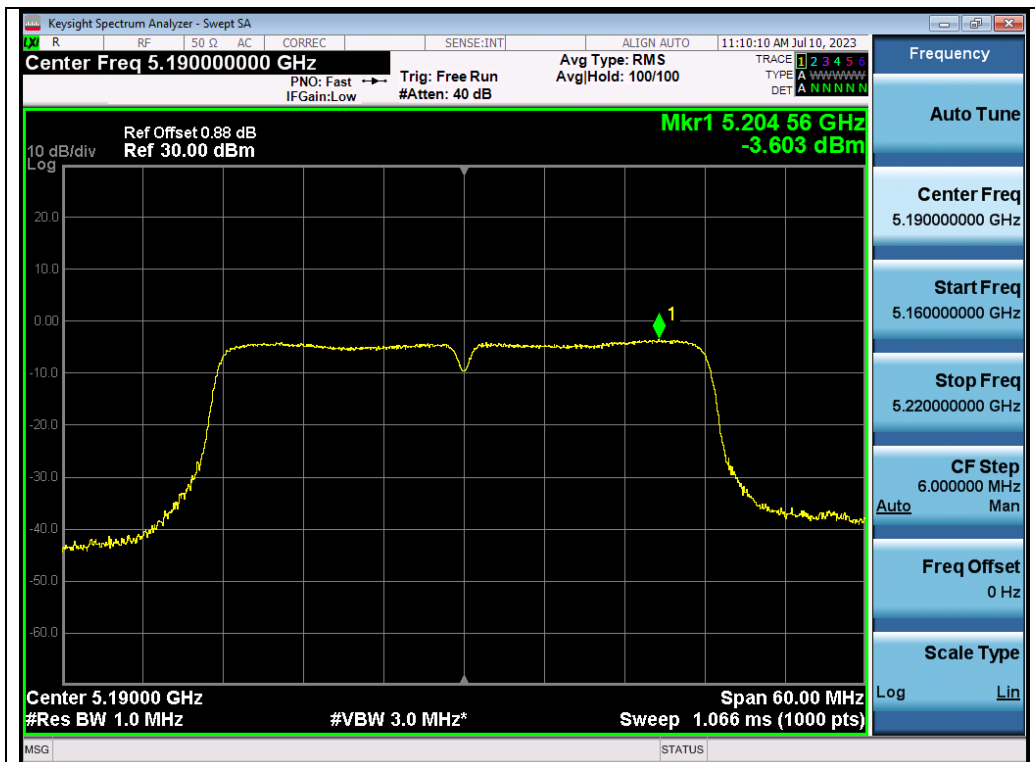

Test_Graph_802.11n40_ANT1_5190_MCS0_PSD

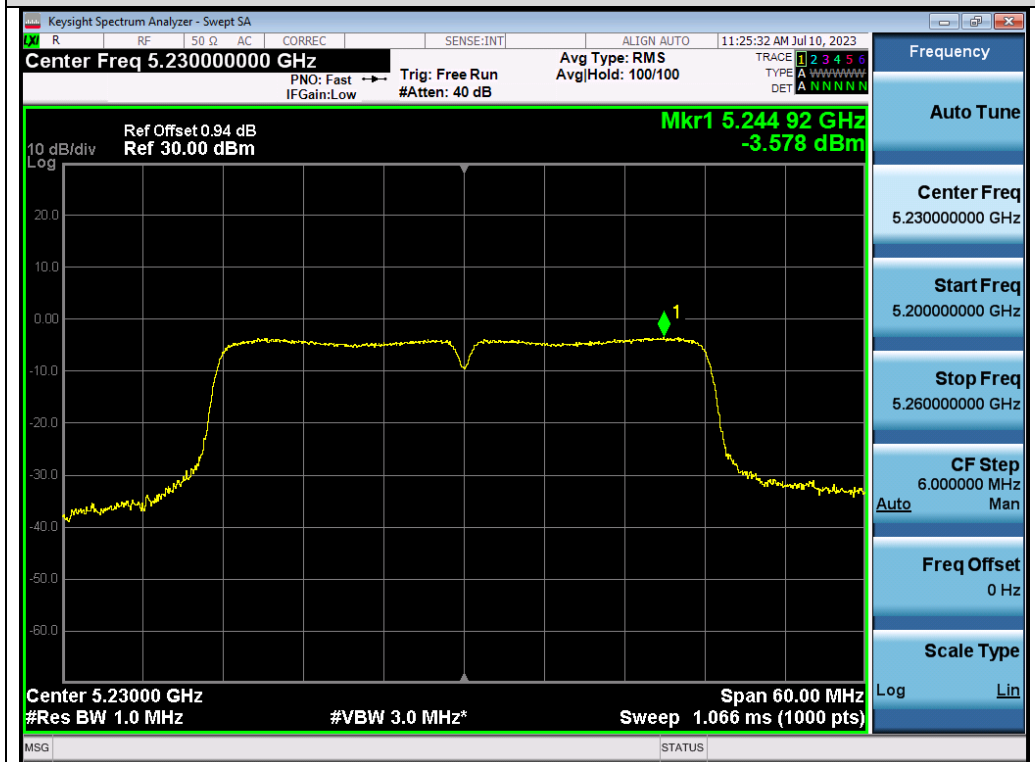

Test_Graph_802.11n40_ANT1_5230_MCS0_PSD

Any report having not been signed by authorized approver, or having been altered without authorization, or having not been stamped by the "Dedicated Testing/Inspection Stamp" is deemed to be invalid. Copying or excerpting portion of, or altering the content of the report is not permitted without the written authorization of AGC. The test results presented in the report apply only to the tested sample. Any objections to report issued by AGC should be submitted to AGC within 15days after the issuance of the test report. Further enquiry of validity or verification of the test report should be addressed to AGC by agc01@agccert.com.