



TEST REPORT

FCC PART 15 SUBPART C 15.247

Report Reference No.: **CTL1803164011-WF01**

Compiled by:
(position+printed name+signature)

Allen Wang
(File administrators)

Allen Wang

Tested by:
(position+printed name+signature)

Nice Nong
(Test Engineer)

Nice Nong

Approved by:
(position+printed name+signature)

Ivan Xie
(Manager)

Ivan Xie

Product Name.....: LoRa Platinum Temperature Sensor

Model/Type reference: 100-00159

Trade Mark: Lansitec

FCC ID: 2APPL-100-00159

Applicant's name: **Nanjing Lansitec Information Technology Co., LTD**

Address of applicant: First Floor, No. 8 Huashen Avenue, Yuhuatai District, Nanjing ,
Jiangsu Province, China

Test Firm: **Shenzhen CTL Testing Technology Co., Ltd.**

Address of Test Firm: Floor 1-A, Baisha Technology Park, No.3011, Shahexi Road,
Nanshan District, Shenzhen, China 518055

Test specification

Standard.....: **47 CFR FCC Part 15 Subpart C 15.247**

TRF Originator: Shenzhen CTL Testing Technology Co., Ltd.

Master TRF: Dated 2011-01

Date of Receipt.....: Mar. 26, 2018

Date of Test Date.....: Mar. 26, 2018–Apr. 27, 2018

Data of Issue.....: Apr. 27, 2018

Result.....: **Pass**

Shenzhen CTL Testing Technology Co., Ltd. All rights reserved.

This publication may be reproduced in whole or in part for non-commercial purposes as long as the Shenzhen CTL Testing Technology Co., Ltd. is acknowledged as copyright owner and source of the material. Shenzhen CTL Testing Technology Co., Ltd. takes no responsibility for and will not assume liability for damages resulting from the reader's interpretation of the reproduced material due to its placement and context.

TEST REPORT

Test Report No. :	CTL1803164011-WF01	Apr. 27, 2018 Date of issue
--------------------------	---------------------------	--------------------------------

Equipment under Test : LoRa Platinum Temperature Sensor

Model /Type : 100-00159

Applicant : **Nanjing Lansitec Information Technology Co., LTD**

Address : First Floor, No. 8 Huashen Avenue, Yuhuatai District, Nanjing ,
Jiangsu Province, China

Manufacturer : **Nanjing Lansitec Information Technology Co., LTD**

Address : First Floor, No. 8 Huashen Avenue, Yuhuatai District, Nanjing ,
Jiangsu Province, China

Test result	Pass *
--------------------	---------------

* In the configuration tested, the EUT complied with the standards specified page 5.

The test report merely corresponds to the test sample.

It is not permitted to copy extracts of these test result without the written permission of the test laboratory.

**** Modified History ****

Revisions	Description	Issued Data	Report No.	Remark
Version 1.0	Initial Test Report Release	2018-4-27	CTL1803164011-WF01	Tracy Qi



Table of Contents

Page

1. SUMMARY.....	5
1.1. TEST STANDARDS.....	5
1.2. TEST DESCRIPTION.....	5
1.3. TEST FACILITY.....	6
1.4. STATEMENT OF THE MEASUREMENT UNCERTAINTY.....	6
2. GENERAL INFORMATION.....	7
2.1. ENVIRONMENTAL CONDITIONS.....	7
2.2. GENERAL DESCRIPTION OF EUT.....	7
2.3. DESCRIPTION OF TEST MODES AND TEST FREQUENCY.....	7
2.4. EQUIPMENTS USED DURING THE TEST.....	9
2.5. RELATED SUBMITTAL(S) / GRANT (S).....	9
2.6. MODIFICATIONS.....	9
3. TEST CONDITIONS AND RESULTS.....	10
3.1. CONDUCTED EMISSIONS TEST.....	10
3.2. RADIATED EMISSIONS AND BAND EDGE.....	11
3.3. MAXIMUM PEAK OUTPUT POWER.....	17
3.4. 20dB BANDWIDTH.....	19
3.5. FREQUENCY SEPARATION.....	21
3.6. NUMBER OF HOPPING FREQUENCY.....	22
3.7. TIME OF OCCUPANCY (DWELL TIME).....	23
3.8. OUT-OF-BAND EMISSIONS.....	24
3.9. PSEUDORANDOM FREQUENCY HOPPING SEQUENCE.....	27
3.10. ANTENNA REQUIREMENT.....	28
4. TEST SETUP PHOTOS OF THE EUT.....	29
5. PHOTOS OF THE EUT.....	30

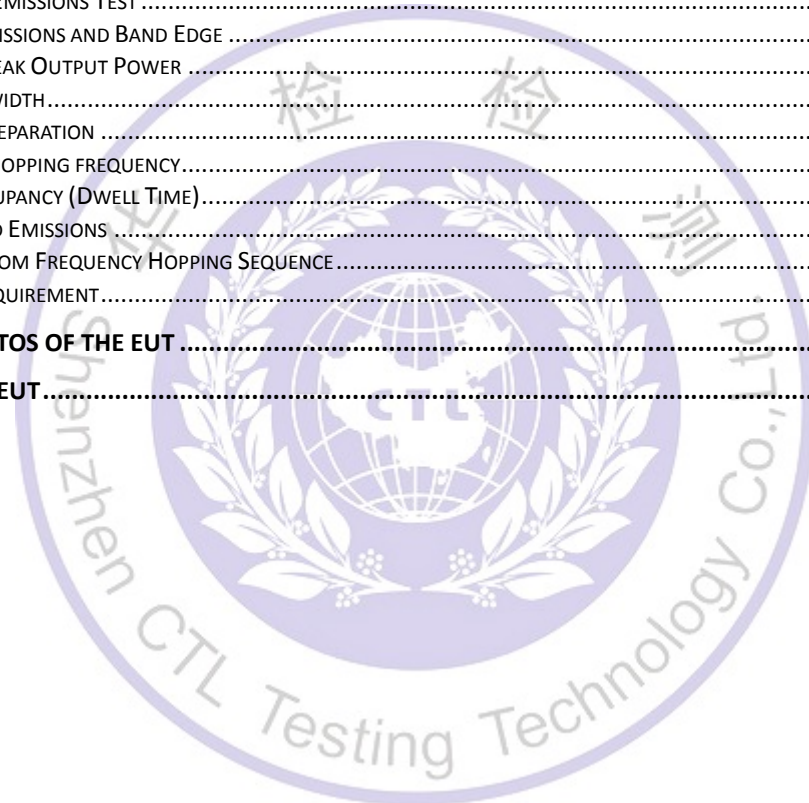

1. SUMMARY

1.1. TEST STANDARDS

The tests were performed according to following standards:

[FCC Rules Part 15.247](#): Frequency Hopping, Direct Spread Spectrum and Hybrid Systems that are in operation within the bands of 902-928 MHz, 2400-2483.5 MHz, and 5725-5850 MHz

[ANSI C63.10:2013](#) : American National Standard for Testing Unlicensed Wireless Devices

1.2. Test Description

FCC PART 15.247		
FCC Part 15.207	AC Power Conducted Emission	N/A
FCC Part 15.247(a)(1)(i)	20dB Bandwidth & 99% Bandwidth	PASS
FCC Part 15.247(d)	Spurious RF Conducted Emission	PASS
FCC Part 15.247(b)(2)	Maximum Peak Output Power	PASS
FCC Part 15.247(b)	Pseudorandom Frequency Hopping Sequence	PASS
FCC Part 15.247(a)(1)(i)	Number of hopping frequency& Time of Occupancy	PASS
FCC Part 15.247(a)(1)	Frequency Separation	PASS
FCC Part 15.205/15.209	Radiated Emissions	PASS
FCC Part 15.247(d)	Band Edge Compliance of RF Emission	PASS



1.3. Test Facility

1.3.1 Address of the test laboratory

Shenzhen CTL Testing Technology Co., Ltd.

Floor 1-A, Baisha Technology Park, No. 3011, Shahexi Road, Nanshan, Shenzhen 518055 China

There is one 3m semi-anechoic chamber and two line conducted labs for final test. The Test Sites meet the requirements in documents ANSI C63.4 and CISPR 32/EN 55032 requirements.

1.3.2 Laboratory accreditation

The test facility is recognized, certified, or accredited by the following organizations:

IC Registration No.: 9618B

The 3m alternate test site of Shenzhen CTL Testing Technology Co., Ltd. EMC Laboratory has been registered by Certification and Engineer Bureau of Industry Canada for the performance of with Registration No.: 9618B on November 13, 2013.

FCC-Registration No.: 399832

Shenzhen CTL Testing Technology Co., Ltd. EMC Laboratory has been registered and fully described in a report filed with the (FCC) Federal Communications Commission. The acceptance letter from the FCC is maintained in our files. Registration 399832, December 08, 2017.

1.4. Statement of the measurement uncertainty

The data and results referenced in this document are true and accurate. The reader is cautioned that there may be errors within the calibration limits of the equipment and facilities. The measurement uncertainty was calculated for all measurements listed in this test report acc. to CISPR 16 - 4 "Specification for radio disturbance and immunity measuring apparatus and methods – Part 4: Uncertainty in EMC Measurements" and is documented in the Shenzhen CTL Testing Technology Co., Ltd. quality system acc. to DIN EN ISO/IEC 17025. Furthermore, component and process variability of devices similar to that tested may result in additional deviation. The manufacturer has the sole responsibility of continued compliance of the device.

Hereafter the best measurement capability for CTL laboratory is reported:

Test	Measurement Uncertainty	Notes
Transmitter power conducted	±0.57 dB	(1)
Transmitter power Radiated	±2.20 dB	(1)
Conducted spurious emission 9KHz-40 GHz	±2.20 dB	(1)
Occupied Bandwidth	±0.01ppm	(1)
Radiated Emission 30~1000MHz	±4.10dB	(1)
Radiated Emission Above 1GHz	±4.32dB	(1)
Conducted Disturbance0.15~30MHz	±3.20dB	(1)

- (1) This uncertainty represents an expanded uncertainty expressed at approximately the 95% confidence level using a coverage factor of k=2.

2. GENERAL INFORMATION

2.1. Environmental conditions

During the measurement the environmental conditions were within the listed ranges:

Normal Temperature:	25°C
Relative Humidity:	55 %
Air Pressure:	101 kPa

2.2. General Description of EUT

Product Name:	LoRa Platinum Temperature Sensor
Model/Type reference:	100-00159
Power supply:	DC 3.6V
900MHz ISM Band wireless	
Operation frequency:	902.3MHz~914.9MHz
Modulation:	LoRa
Channel number:	64
Channel separation:	200KHz
Antenna type:	External Antenna
Antenna gain:	1.0dBi

Note: For more details, refer to the user's manual of the EUT.

2.3. Description of Test Modes and Test Frequency

The Applicant provides communication tools software to control the EUT for staying in continuous transmitting and receiving mode for testing.

Operation Frequency :

Channel number	Freq. (MHz)	Channel number	Freq. (MHz)	Channel number	Freq. (MHz)	Channel number	Freq. (MHz)
0	902.3	20	906.3	40	910.3	60	914.3
1	902.5	21	906.5	41	910.5	61	914.5
2	902.7	22	906.7	42	910.7	62	914.7
3	902.9	23	906.9	43	910.9	63	914.9
4	903.1	24	907.1	44	911.1	-	-
5	903.3	25	907.3	45	911.3	-	-
6	903.5	26	907.5	46	911.5	-	-
7	903.7	27	907.7	47	911.7	-	-
8	903.9	28	907.9	48	911.9	-	-
9	904.1	29	908.1	49	912.1	-	-
10	904.3	30	908.3	50	912.3	-	-
11	904.5	31	908.5	51	912.5	-	-
12	904.7	32	908.7	52	912.7	-	-
13	904.9	33	908.9	53	912.9	-	-
14	905.1	34	909.1	54	913.1	-	-
15	905.3	35	909.3	55	913.3	-	-
16	905.5	36	909.5	56	913.5	-	-
17	905.7	37	909.7	57	913.7	-	-
18	905.9	38	909.9	58	913.9	-	-
19	906.1	39	910.1	59	914.1	-	-

Note: We choose channel 0, channel 32, channel 63 for testing.



2.4. Equipments Used during the Test

Test Equipment	Manufacturer	Model No.	Serial No.	Calibration Date	Calibration Due Date
LISN	R&S	ENV216	3560.6550.12	2017/06/02	2018/06/01
LISN	R&S	ESH2-Z5	860014/010	2017/06/02	2018/06/01
Bilog Antenna	Sunol Sciences Corp.	JB1	A061713	2017/06/02	2018/06/01
EMI Test Receiver	R&S	ESCI	103710	2017/06/02	2018/06/01
Spectrum Analyzer	Agilent	E4407B	MY41440676	2017/05/21	2018/05/20
Spectrum Analyzer	Agilent	N9020	US46220290	2018/01/16	2019/01/15
Power Meter	Anritsu	ML2487B	110553	2017/06/02	2018/06/01
Power Sensor	Anritsu	MA2411B	100345	2017/05/21	2018/05/20
Controller	EM Electronics	Controller EM 1000	N/A	2017/05/21	2018/05/20
Horn Antenna	Sunol Sciences Corp.	DRH-118	A062013	2017/05/19	2018/05/18
Active Loop Antenna	SCHWARZBECK	FMZB1519	1519-037	2017/05/19	2018/05/18
Amplifier	Agilent	8449B	3008A02306	2017/05/19	2018/05/18
Amplifier	Agilent	8447D	2944A10176	2017/05/19	2018/05/18
Temperature/Humidity Meter	Gangxing	CTH-608	02	2017/05/20	2018/05/19
High-Pass Filter	K&L	9SH10-2700/X 12750-O/O	N/A	2017/05/20	2018/05/19
High-Pass Filter	K&L	41H10-1375/U 12750-O/O	N/A	2017/05/20	2018/05/19
Coaxial Cables	HUBER+SUHNER	SUCOFLEX 104PEA-10M	10m	2017/06/02	2018/06/01
Coaxial Cables	HUBER+SUHNER	SUCOFLEX 104PEA-3M	3m	2017/06/02	2018/06/01
Coaxial Cables	HUBER+SUHNER	SUCOFLEX 104PEA-3M	3m	2017/06/02	2018/06/01
RF Cable	Megalon	RF-A303	N/A	2017/06/02	2018/06/01

The calibration interval was one year

2.5. Related Submittal(s) / Grant (s)

This submittal(s) (test report) is intended to comply with Section 15.247 of the FCC Part 15 Subpart C Rules.

2.6. Modifications

No modifications were implemented to meet testing criteria.

3. TEST CONDITIONS AND RESULTS

3.1. Conducted Emissions Test

LIMIT

According to FCC CFR Title 47 Part 15 Subpart C Section 15.207, AC Power Line Conducted Emissions Limits for Licence-Exempt Radio Apparatus as below:

Frequency range (MHz)	Limit (dBuV)	
	Quasi-peak	Average
0.15-0.5	66 to 56*	56 to 46*
0.5-5	56	46
5-30	60	50

* Decreases with the logarithm of the frequency.

TEST CONFIGURATION

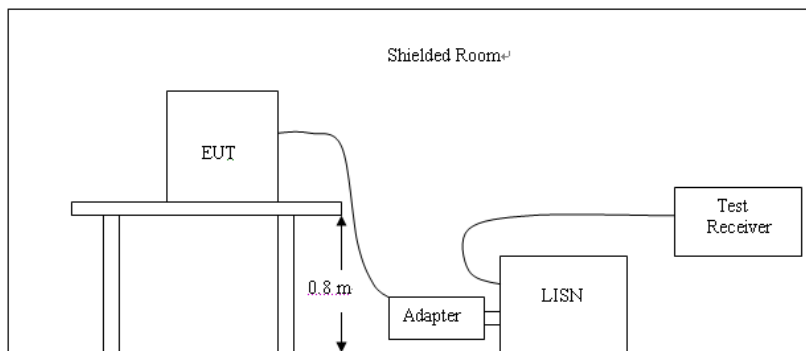

TEST PROCEDURE

1. The equipment was set up as per the test configuration to simulate typical actual usage per the user's manual. The EUT is a tabletop system; a wooden table with a height of 0.8 meters is used and is placed on the ground plane as per ANSI C63.10:2013.
2. Support equipment, if needed, was placed as per ANSI C63.10:2013
3. All I/O cables were positioned to simulate typical actual usage as per ANSI C63.10:2013.
4. The adapter received AC120V/60Hz power through a Line Impedance Stabilization Network (LISN) which supplied power source and was grounded to the ground plane.
5. All support equipments received AC power from a second LISN, if any.
6. The EUT test program was started. Emissions were measured on each current carrying line of the EUT using a spectrum Analyzer / Receiver connected to the LISN powering the EUT. The LISN has two monitoring points: Line 1 (Hot Side) and Line 2 (Neutral Side). Two scans were taken: one with Line 1 connected to Analyzer / Receiver and Line 2 connected to a 50 ohm load; the second scan had Line 1 connected to a 50 ohm load and Line 2 connected to the Analyzer / Receiver.
7. Analyzer / Receiver scanned from 150 KHz to 30MHz for emissions in each of the test modes.
8. During the above scans, the emissions were maximized by cable manipulation.

TEST RESULTS

Not applicable to this device.

3.2. Radiated Emissions and Band Edge

Limit

For intentional device, according to § 15.209(a), the general requirement of field strength of radiated emission out of authorized band shall not exceed the following table at a 3 meters measurement distance.

In addition, radiated emissions which fall in the restricted bands, as defined in §15.205(a), must also comply with the radiated emission limits specified in §15.209(a)

Except when the requirements applicable to a given device state otherwise, emissions from licence-exempt transmitters shall comply with the field strength limits shown in table below. Additionally, the level of any transmitter emission shall not exceed the level of the transmitter’s fundamental emission

Unwanted emissions that fall into restricted bands shall comply with the limits specified in RSS-Gen; and Unwanted emissions that do not fall within the restricted frequency bands shall comply either with the limits specified in the applicable RSS or with those specified in this RSS-Gen.

Radiated emission limits

Frequency (MHz)	Distance (Meters)	Radiated (dBµV/m)	Radiated (µV/m)
0.009-0.49	3	$20\log(2400/F(\text{KHz}))+40\log(300/3)$	$2400/F(\text{KHz})$
0.49-1.705	3	$20\log(24000/F(\text{KHz}))+40\log(30/3)$	$24000/F(\text{KHz})$
1.705-30	3	$20\log(30)+40\log(30/3)$	30
30-88	3	40.0	100
88-216	3	43.5	150
216-960	3	46.0	200
Above 960	3	54.0	500

TEST CONFIGURATION

(A) Radiated Emission Test Set-Up, Frequency Below 30MHz

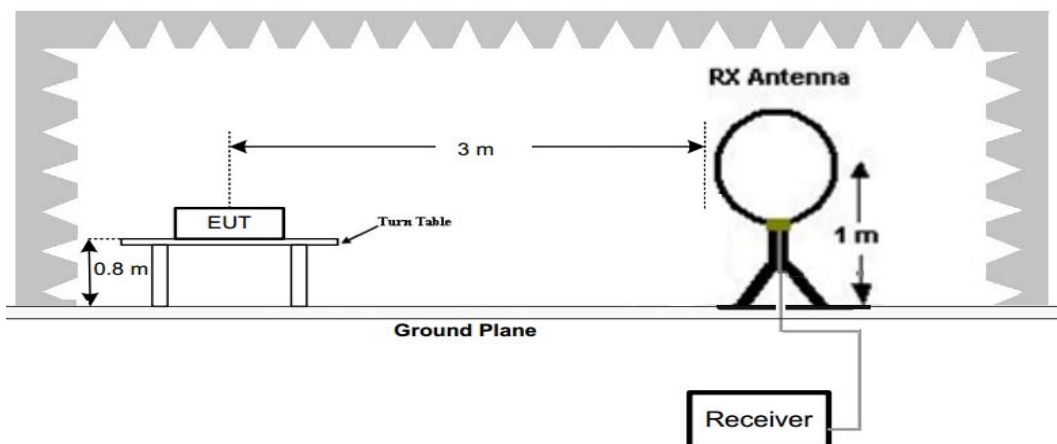

(B) Radiated Emission Test Set-Up, Frequency below 1000MHz

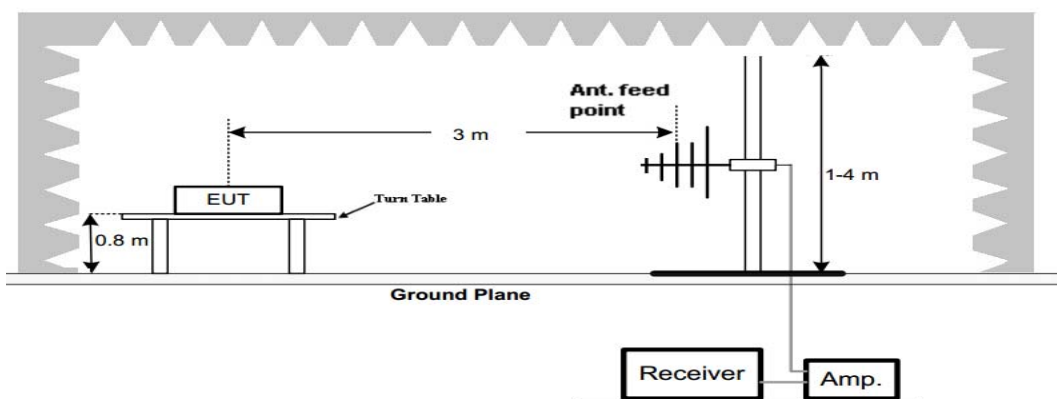

(C) Radiated Emission Test Set-Up, Frequency above 1000MHz

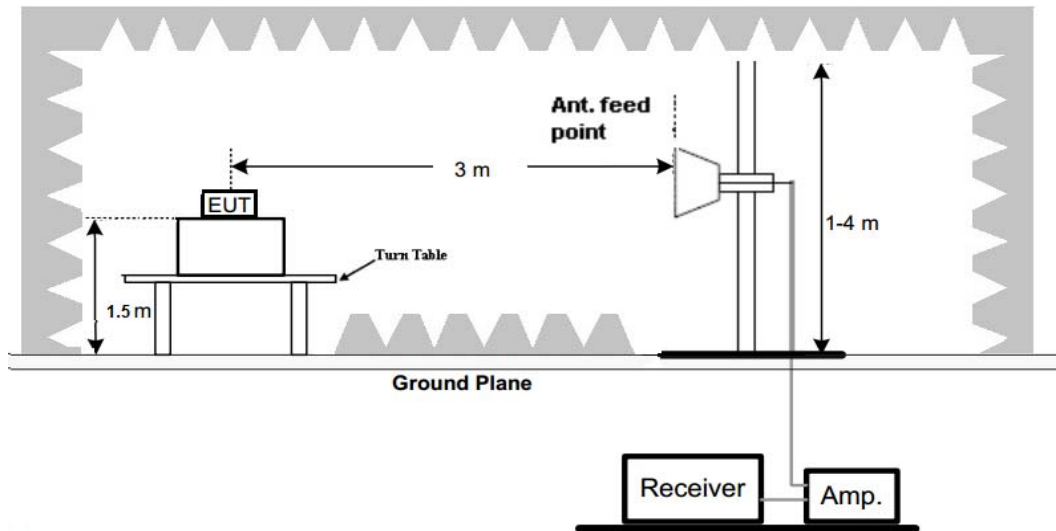

Test Procedure

1. The EUT was placed on turn table which is 0.8m above ground plane for below 1GHz test, and on a low permittivity and low loss tangent turn table which is 1.5m above ground plane for above 1GHz test.
2. Maximum procedure was performed by raising the receiving antenna from 1m to 4m and rotating the turn table from 0° to 360° to acquire the highest emissions from EUT
3. And also, each emission was to be maximized by changing the polarization of receiving antenna both horizontal and vertical.
4. Repeat above procedures until all frequency measurements have been completed.

TEST RESULTS

Remark:

1. Radiated Emission measured from 9 KHz to 10th harmonic of fundamental and only worst point recorded in this report.
2. By preliminary testing and verifying three axis (X, Y and Z) position of EUT transmitted status, it was found that "Z axis" position was the worst, and test data recorded in this report.

H:

SWEEP TABLE: "test (30M-1G)"

Short Description:		Field Strength			
Start	Stop	Detector	Meas. Time	IF Bandw.	Transducer
Frequency	Frequency				
30.0 MHz	1.0 GHz	MaxPeak	300.0 ms	120 kHz	VULB 9168

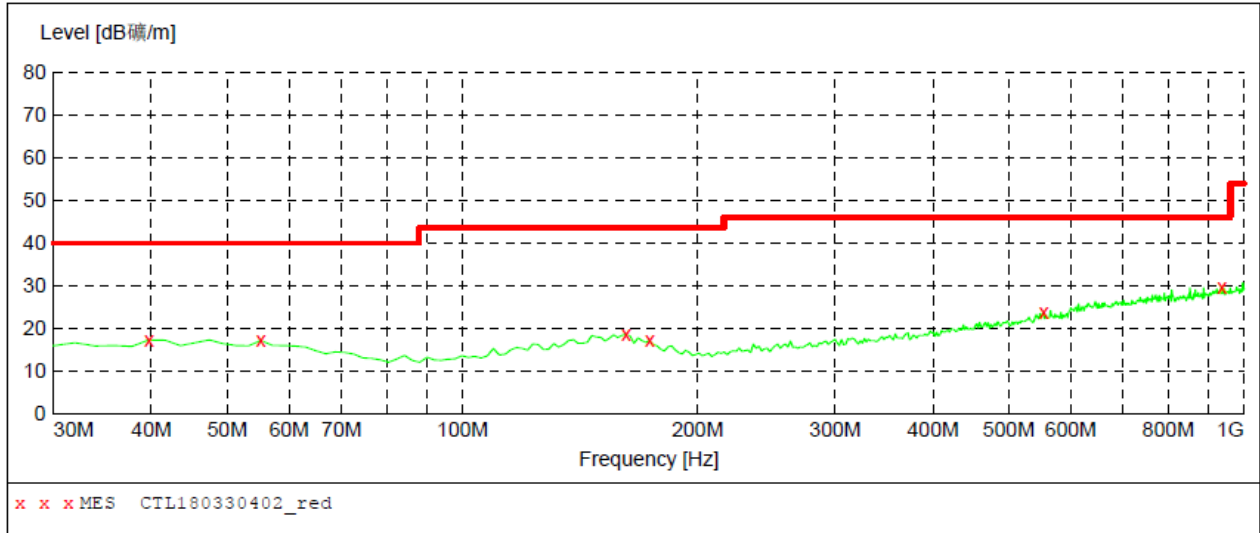

V:

SWEEP TABLE: "test (30M-1G)"

Short Description:		Field Strength			
Start	Stop	Detector	Meas. Time	IF Bandw.	Transducer
30.0 MHz	1.0 GHz	MaxPeak	300.0 ms	120 kHz	VULB 9168

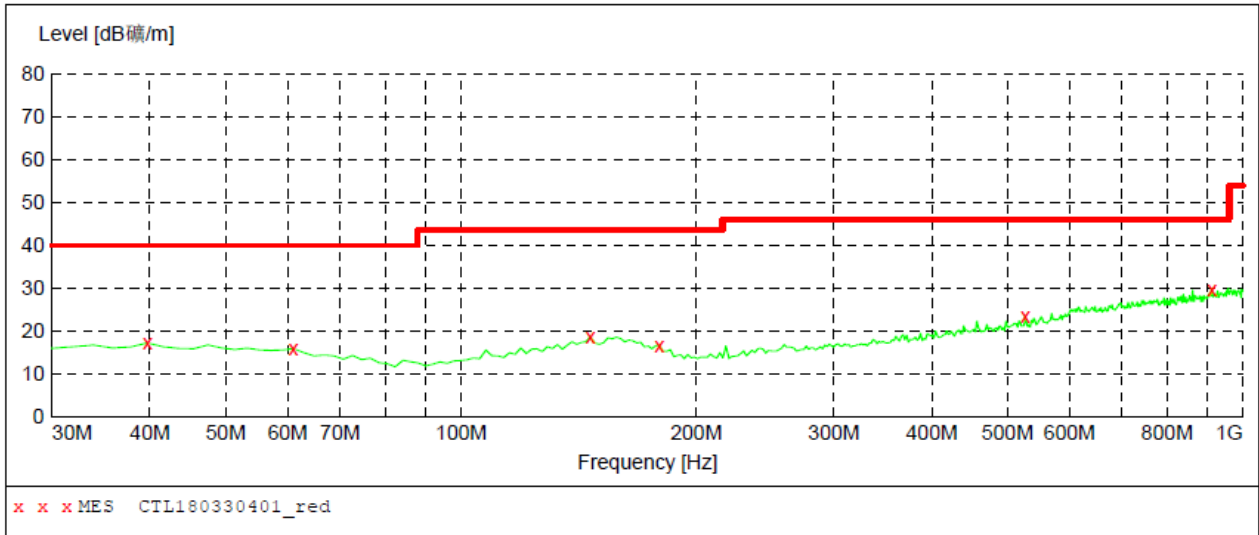

CH	Antenna	Frequency (MHz)	Reading Level (dBuV/m)	Factor (dB)	Measure Level (dBuV/m)	Limit (dBuV/m)	Margin (dB)	Detector
0	V	1804.60	57.44	-0.40	57.04	74.00	16.96	PK
	V	1804.60	49.62	-0.40	49.22	54.00	4.78	AV
	V	2706.90	53.68	2.10	55.78	74.00	18.22	PK
	V	2706.90	45.85	2.10	47.95	54.00	6.05	AV
	V	3609.20	48.67	3.50	52.17	74.00	21.83	PK
	V	3609.20	42.54	3.50	46.04	54.00	7.96	AV
	V	10000.00	31.41	18.90	50.31	54(Note 4)	3.69	PK
32	V	1817.40	57.17	-0.30	56.87	74.00	17.13	PK
	V	1817.40	49.55	-0.30	49.25	54.00	4.75	AV
	V	2726.10	51.81	2.80	54.61	74.00	19.39	PK
	V	2726.10	46.26	2.10	48.36	54.00	5.64	AV
	V	3634.80	49.52	3.50	53.02	74.00	20.98	PK
	V	3634.80	43.64	3.50	47.14	54.00	6.86	AV
	V	10000.00	32.36	18.90	51.26	54(Note 4)	2.74	PK
63	V	1829.80	56.24	-0.30	55.94	74.00	18.06	PK
	V	1829.80	48.37	-0.30	48.07	54.00	5.93	AV
	V	2744.70	51.48	2.30	53.78	74.00	20.22	PK
	V	2744.70	43.78	2.30	46.08	54.00	7.92	AV
	V	3659.60	48.44	3.80	52.24	74.00	21.76	PK
	V	3659.60	42.21	3.80	46.01	54.00	7.99	AV
	V	10000.00	31.86	18.90	50.76	54(Note 4)	3.24	PK

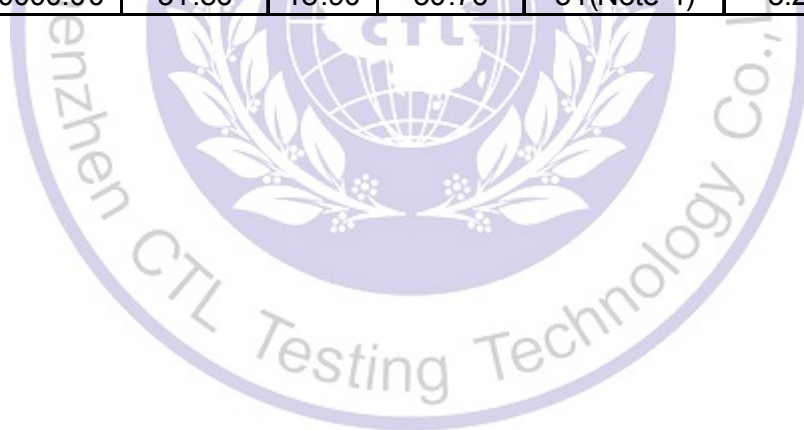

CH	Antenna	Frequency (MHz)	Reading Level (dBuV/m)	Factor (dB)	Measure Level (dBuV/m)	Limit (dBuV/m)	Margin (dB)	Detector
0	H	1804.60	56.54	-0.40	56.14	74.00	17.86	PK
	H	1804.60	49.72	-0.40	49.32	54.00	4.68	AV
	H	2706.90	52.65	2.10	54.75	74.00	19.25	PK
	H	2706.90	45.91	2.10	48.01	54.00	5.99	AV
	H	3609.20	47.74	3.50	51.24	74.00	22.76	PK
	H	3609.20	44.12	3.50	47.62	54.00	6.38	AV
	H	10000.00	31.83	18.90	50.73	54(Note 4)	3.27	PK
32	H	1817.40	57.58	-0.30	57.28	74.00	16.72	PK
	H	1817.40	50.91	-0.30	50.61	54.00	3.39	AV
	H	2726.10	52.47	2.80	55.27	74.00	18.73	PK
	H	2726.10	45.99	2.10	48.09	54.00	5.91	AV
	H	3634.80	48.76	3.50	52.26	74.00	21.74	PK
	H	3634.80	42.61	3.50	46.11	54.00	7.89	AV
	H	10000.00	31.84	18.90	50.74	54(Note 4)	3.26	PK
63	H	1829.80	56.72	-0.30	56.42	74.00	17.58	PK
	H	1829.80	49.21	-0.30	48.91	54.00	5.09	AV
	H	2744.70	50.78	2.30	53.08	74.00	20.92	PK
	H	2744.70	45.25	2.30	47.55	54.00	6.45	AV
	H	3659.60	48.14	3.80	51.94	74.00	22.06	PK
	H	3659.60	43.02	3.80	46.82	54.00	7.18	AV
	H	10000.00	32.33	18.90	51.23	54(Note 4)	2.77	PK

REMARKS:

1. Emission level (dBuV/m) =Raw Value (dBuV)+Correction Factor (dB/m)
2. Correction Factor (dB/m) = Antenna Factor (dB/m)+Cable Factor (dB)-Pre-amplifier Factor
3. Margin value = Limit value- Emission level.
4. -- Mean the PK detector measured value is below QP/AV limit.
5. The other emission levels were very low against the limit.
6. RBW100KHz VBW300KHz for test at below 1GHz; RBW1MHz VBW3MHz Peak detector is for PK value, RBW 1MHz VBW10Hz Peak detector is for AV value for test at above 1GHz.

3.3. Maximum Peak Output Power

Limit

The Maximum Peak Output Power Measurement is 30dBm.

Test Procedure

Remove the antenna from the EUT and then connect a low loss RF cable from the antenna port to the power sensor.

Test Configuration

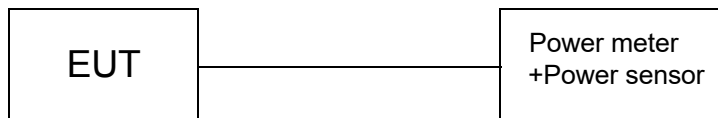

Test Results

Channel	Output power (dBm)	Limit (dBm)	Result
00	14.941	30.00	Pass
32	14.913		
64	14.925		

Note: 1.The test results including the cable lose.

3.4. 20dB Bandwidth

Limit

For frequency hopping systems operating in the 902-928 MHz band. The maximum allowed 20 dB bandwidth of the hopping channel is 500 kHz.

Test Procedure

The transmitter output was connected to the spectrum analyzer through an attenuator. The bandwidth of the fundamental frequency was measured by spectrum analyzer with 30 KHz RBW and 100 KHz VBW.

The 20dB bandwidth is defined as the total spectrum the power of which is higher than peak power minus 20dB.

The occupied bandwidth is the frequency bandwidth such that, below its lower and above its upper frequency limits, the mean powers are each equal to 0.5% of the total mean power of the given emission. The following procedure shall be used for measuring 99% power bandwidth:

RBW=1% to 5% of the OBW

VBW=approximately 3 X RBW

Detector=Peak

Trace Mode: Max Hold

Use the 99% power bandwidth function of the instrument to measure the Occupied Bandwidth and recorded.

Test Configuration



Test Results

Channel	20dB bandwidth (KHz)	99% OBW(KHz)	Result
00	133.6	114.05	Pass
32	133.4	114.02	
64	133.1	114.03	

Test plot as follows:

Normal Modulation

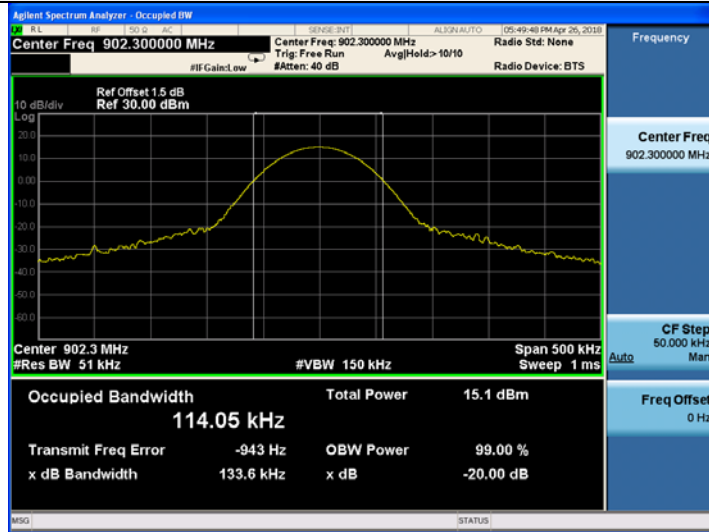

CH00

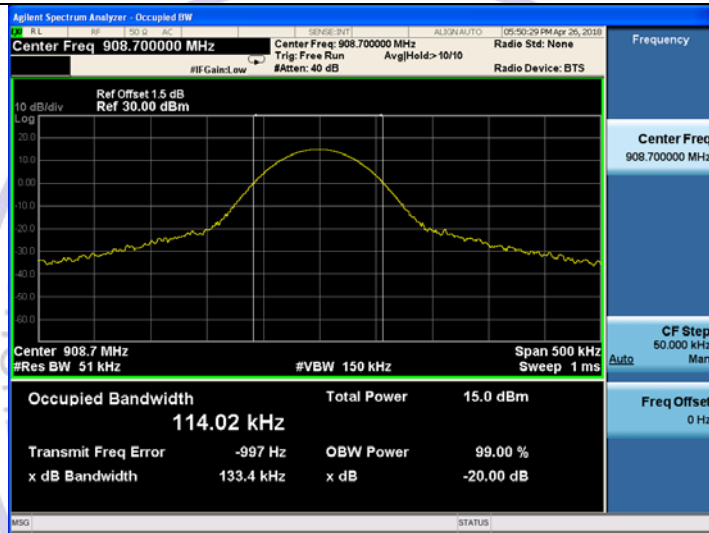

CH32

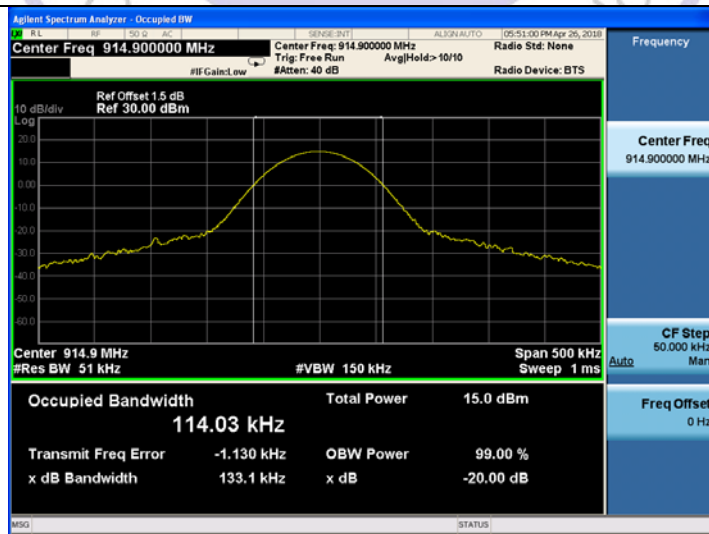

CH64

3.5. Frequency Separation

LIMIT

FHSs shall have hopping channel carrier frequencies separated by a minimum of 25 kHz or the 20 dB bandwidth of the hopping channel, whichever is greater.

TEST PROCEDURE

The transmitter output was connected to the spectrum analyzer through an attenuator. The bandwidth of the fundamental frequency was measured by spectrum analyzer with 100 KHz RBW and 300 KHz VBW.

TEST CONFIGURATION



TEST RESULTS

Channel	Channel Separation (MHz)	Limit	Result
CH00	0.200	25KHz or 20dB bandwidth	Pass
CH01			

Note: We have tested all mode at high, middle and low channel, and recorded worst case at low channel

Test plot as follows:

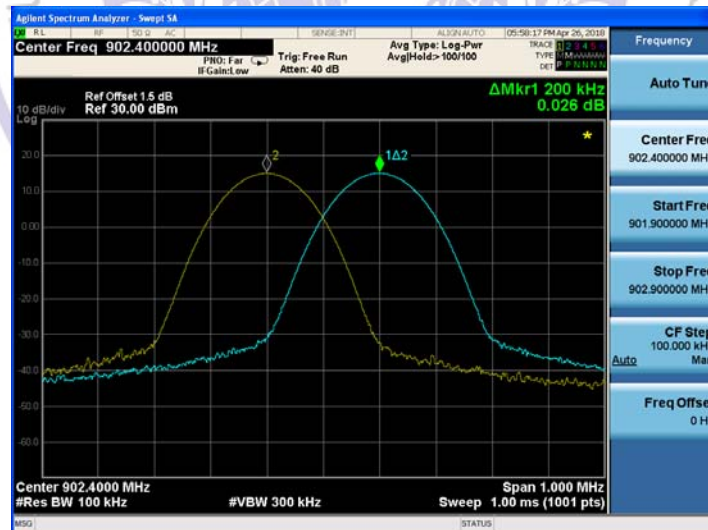

3.6. Number of hopping frequency

Limit

For FHSs in the band 902-928 MHz: if the 20 dB bandwidth of the hopping channel is less than 250 kHz, the system shall use at least 50 hopping channels and the average time of occupancy on any channel shall not be greater than 0.4 seconds within a 20-second period. If the 20 dB bandwidth of the hopping channel is 250 kHz or greater, the system shall use at least 25 hopping channels and the average time of occupancy on any channel shall not be greater than 0.4 seconds within a 10-second period.

Test Procedure

The transmitter output was connected to the spectrum analyzer through an attenuator. Set spectrum analyzer start 902MHz to 928MHz.

Test Configuration



Test Results

Modulation	Number of Hopping Channel	Limit	Result
FHSS	64	≥50	Pass

Test plot as follows:

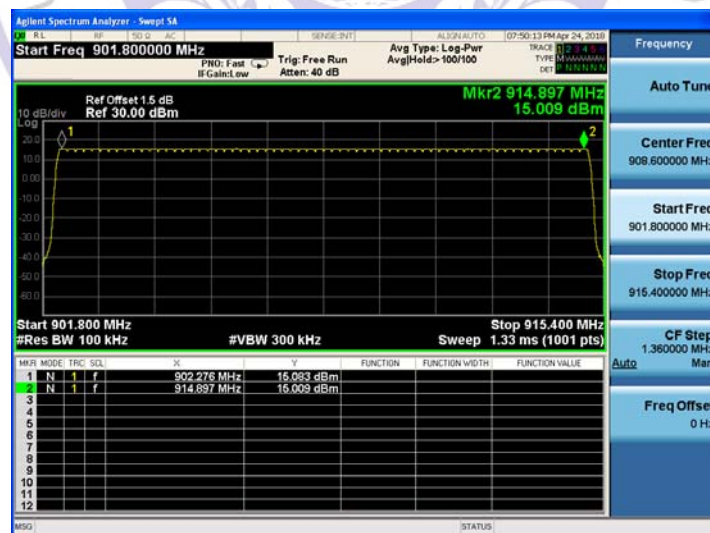

3.7. Time of Occupancy (Dwell Time)

Limit

For FHSs in the band 902-928 MHz: if the 20 dB bandwidth of the hopping channel is less than 250 kHz, the system shall use at least 50 hopping channels and the average time of occupancy on any channel shall not be greater than 0.4 seconds within a 20-second period. If the 20 dB bandwidth of the hopping channel is 250 kHz or greater, the system shall use at least 25 hopping channels and the average time of occupancy on any channel shall not be greater than 0.4 seconds within a 10-second period.

Test Procedure

The transmitter output was connected to the spectrum analyzer through an attenuator. Set center frequency of spectrum analyzer=operating frequency with 1MHz RBW and 1MHz VBW, Span 0Hz.

Test Configuration



Test Results

Total Dwell time(ms)	Limit(ms)	Result
358.4	400	PASS

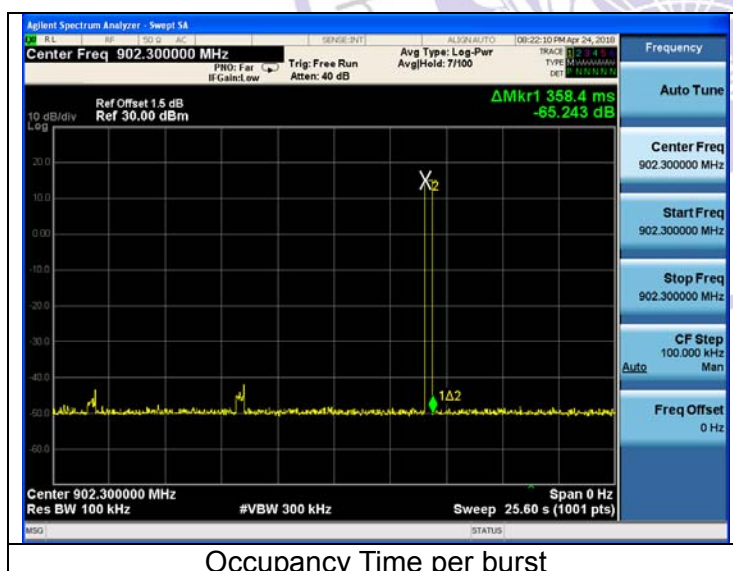

Occupancy Time per burst

3.8. Out-of-band Emissions

Limit

In any 100 kHz bandwidth outside the frequency band in which the spread spectrum or digitally modulated intentional radiator is operating, the radio frequency power that is produced by the intentional radiator shall be at least 20 dB below that in the 100 kHz bandwidth within the band that contains the highest level of the desired power, based on either an RF conducted or a radiated measurement, provided the transmitter demonstrates compliance with the peak conducted power limits. If the transmitter complies with the conducted power limits based on the use of RMS averaging over a time interval, as permitted under paragraph (b)(3) of this section, the attenuation required under this paragraph shall be 30 dB instead of 20 dB. Attenuation below the general limits specified in §15.209(a) is not required.

Test Procedure

Connect the transmitter output to spectrum analyzer using a low loss RF cable, and set the spectrum analyzer to RBW=100 kHz, VBW= 300 kHz, peak detector, and max hold. Measurements utilizing these settings are made of the in-band reference level, band-edge and out-of-band emissions.

Test Configuration



Test Results

Remark: The measurement frequency range is from 30MHz to the 10th harmonic of the fundamental frequency. The lowest, middle and highest channels are tested to verify the spurious emissions and band-edge measurement data.

Test plot as follows:

Normal modulation

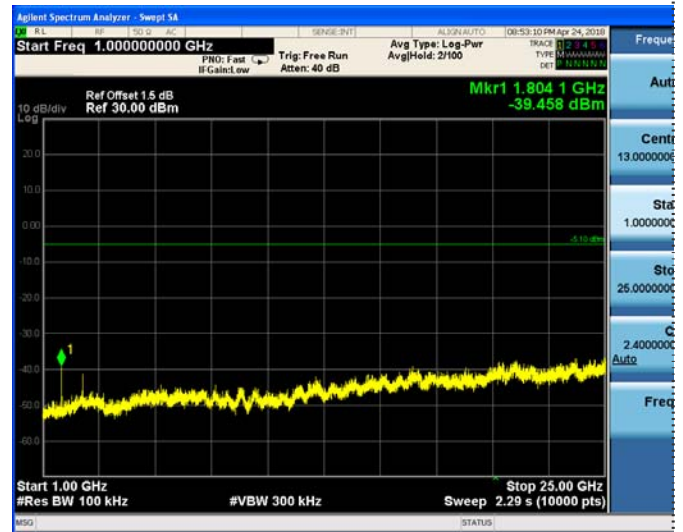
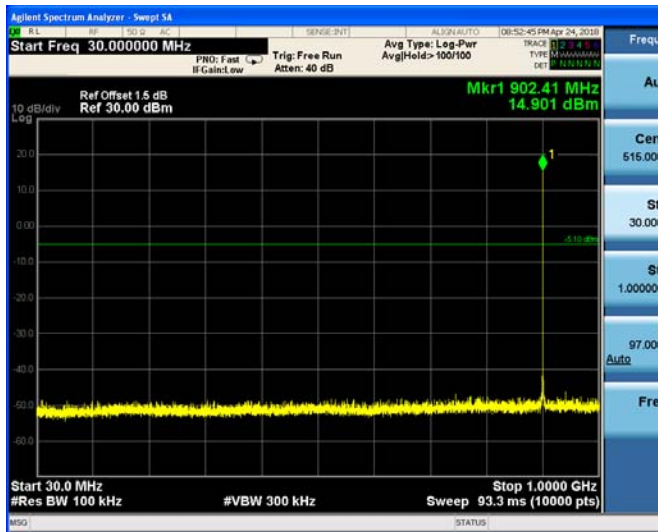

CH00

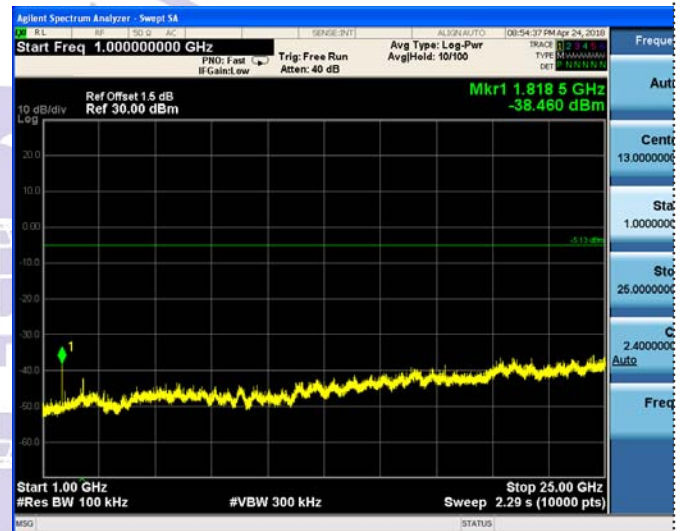
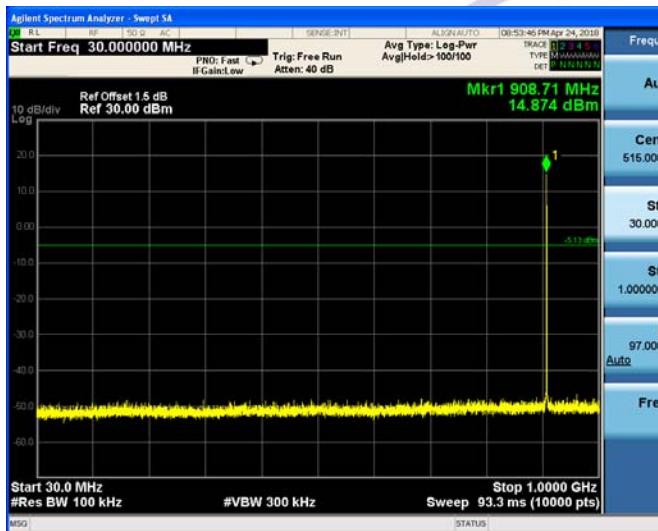

CH32

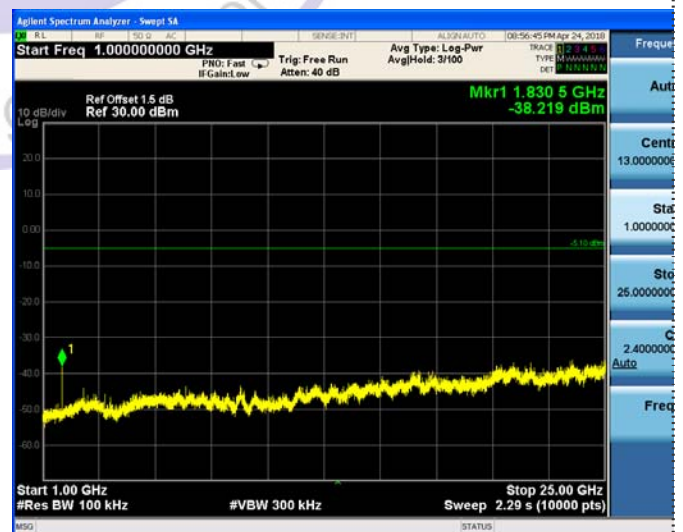
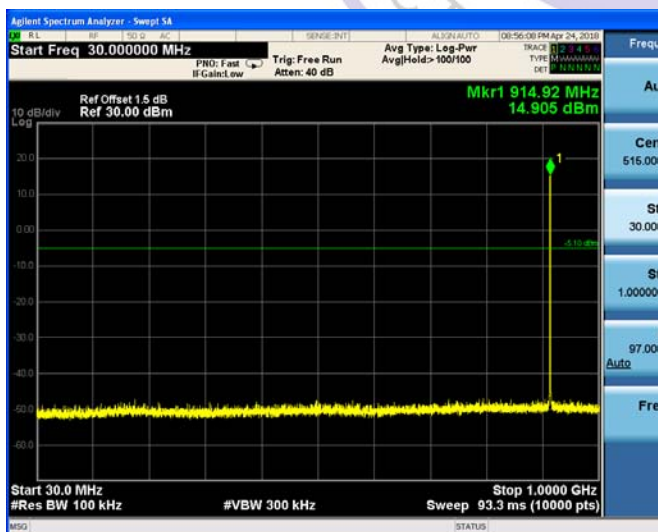

CH63

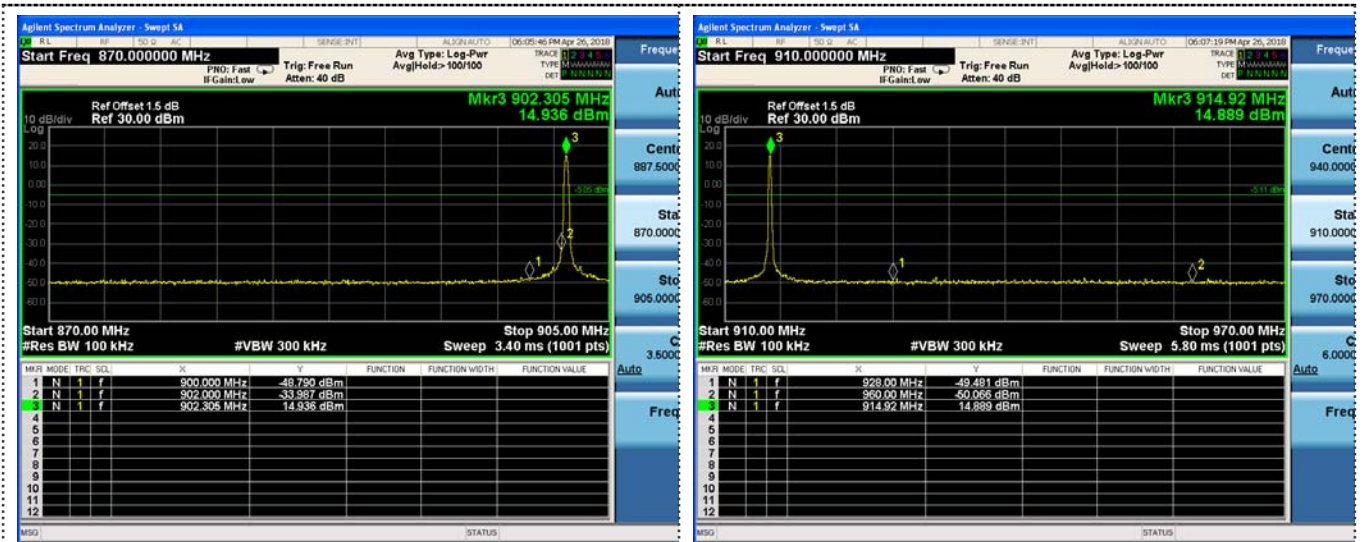

Left Band edge hopping off

Right Band edge hopping off

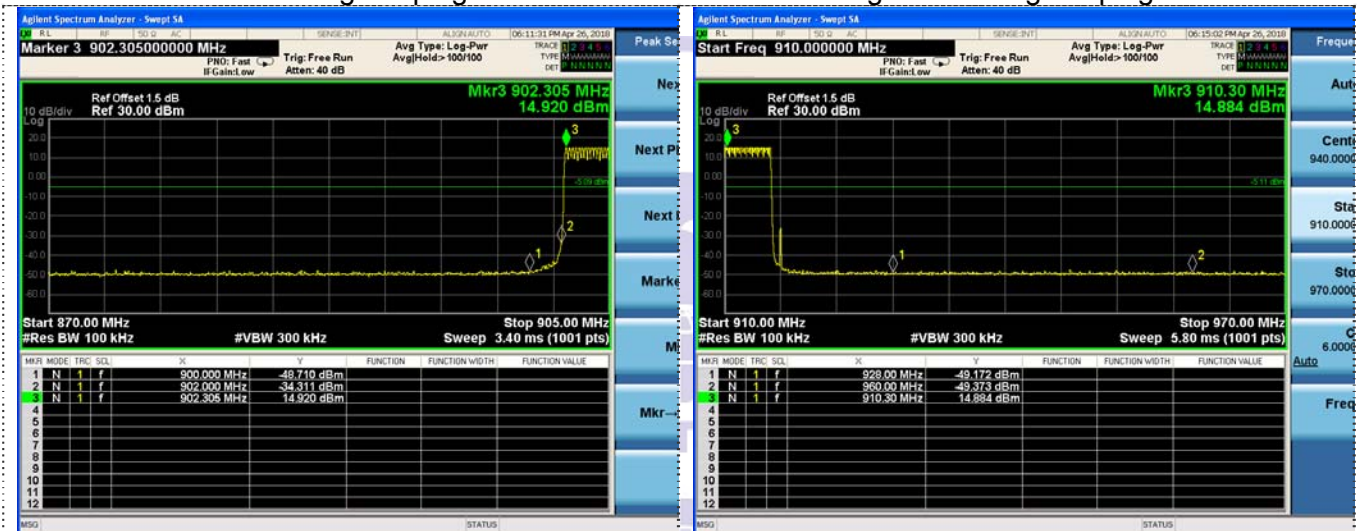

Left Band edge hopping on

Right Band edge hopping on



3.9. Pseudorandom Frequency Hopping Sequence

TEST APPLICABLE

For 47 CFR Part 15C section 15.247 (a) (1) & RSS 247 requirement:

The system shall hop to channel frequencies that are selected at the system hopping rate from a pseudo randomly ordered list of hopping frequencies. Each frequency must be used equally on the average by each transmitter. The system receivers shall have input bandwidths that match the hop-ping channel bandwidths of their corresponding transmitters and shall shift frequencies in synchronization with the transmitted signals.

Test result

Conforms

The device hops on 64 channel frequencies that are selected in a pseudo random order.

An example of the order is:

{48, 25,53,17, 20, 41, 37, 36, 10, 52,15, 44, 30, 6, 54, 42, 33, 5,55, 8, 28, 56, 1,58, 57, 23, 49, 16, 3, 19, 29, 21,59, 43, 31, 9,60, 18, 27, 22, 45, 61, 13, 0, 2, 32, 11, 14, 62, 46, 12, 24, 4, 7, 38, 47, 35, 40, 50, 34, 39, 26, 51,63}

where Channel 0 is 902.3 MHz and Channel 63 is 914.90 MHz.

The dwell time of the hopping is 350ms. Each channel is used equally on average.

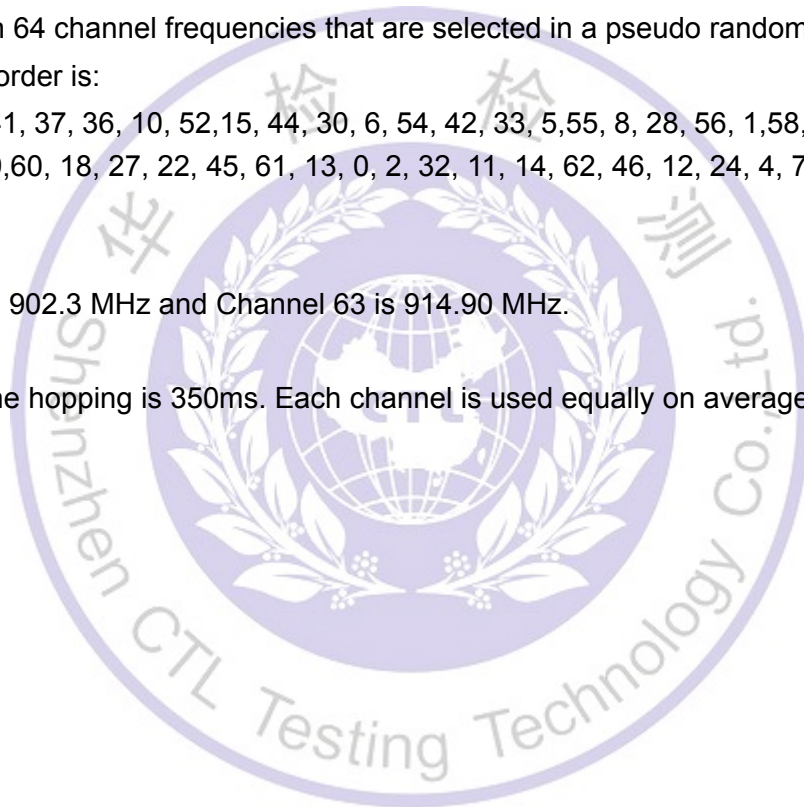

3.10. Antenna Requirement

Standard Applicable

For intentional device, according to FCC 47 CFR Section 15.203:

An intentional radiator shall be designed to ensure that no antenna other than that furnished by the responsible party shall be used with the device. The use of a permanently attached antenna or of an antenna that uses a unique coupling to the intentional radiator, the manufacturer may design the unit so that a broken antenna can be replaced by the user, but the use of a standard antenna jack or electrical connector is prohibited

FCC CFR Title 47 Part 15 Subpart C Section 15.247(c) (1) (I):

(i) Systems operating in the 2400-2483.5 MHz band that is used exclusively for fixed. Point-to-point operations may employ transmitting antennas with directional gain greater than 6dBi provided the maximum conducted output power of the intentional radiator is reduced by 1 dB for every 3 dB that the directional gain of the antenna exceeds 6dBi.

Test Result:

The gains of antenna used for transmitting is 1 dBi, and the antenna connector is designed with permanent attachment and no consideration of replacement. Please see EUT photo for details.

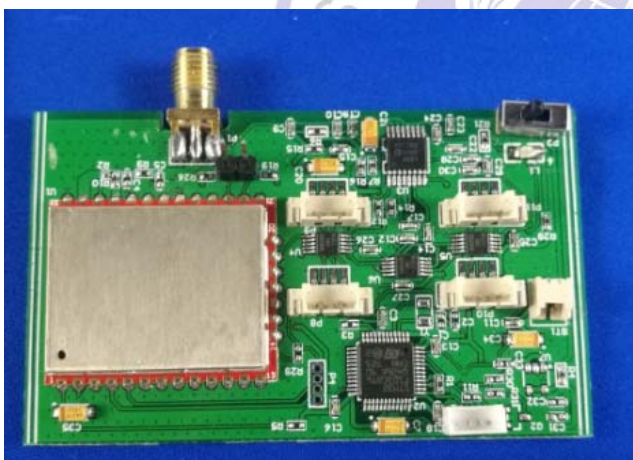

4. Test Setup Photos of the EUT

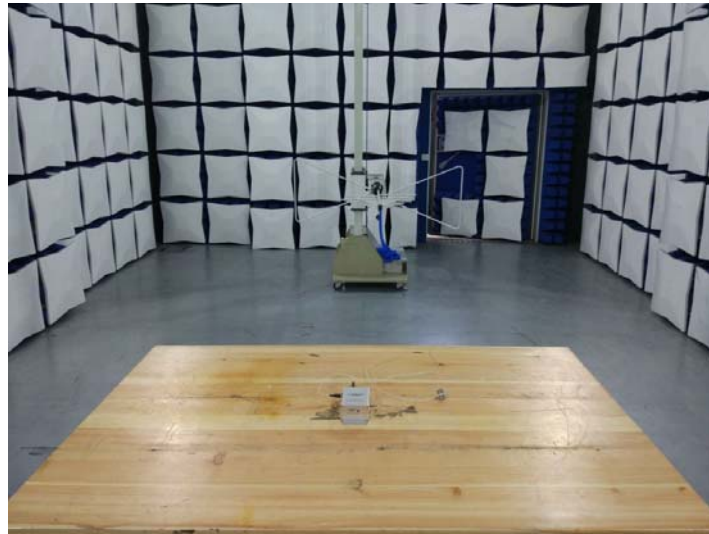

5. Photos of the EUT

External Photos of EUT



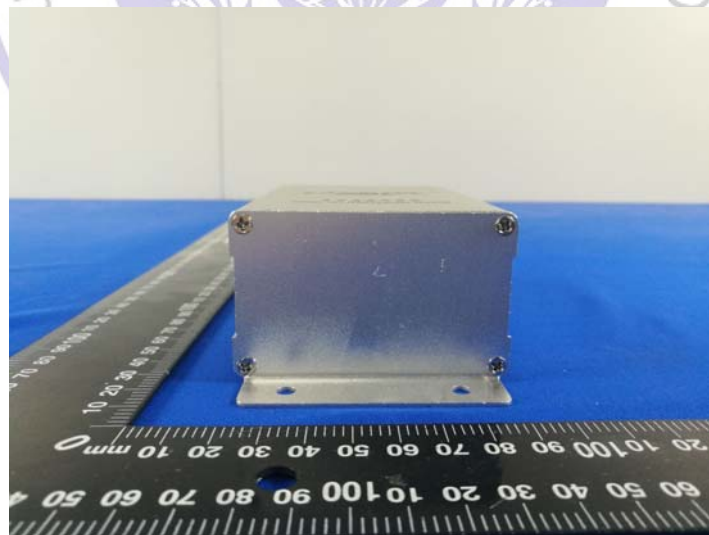
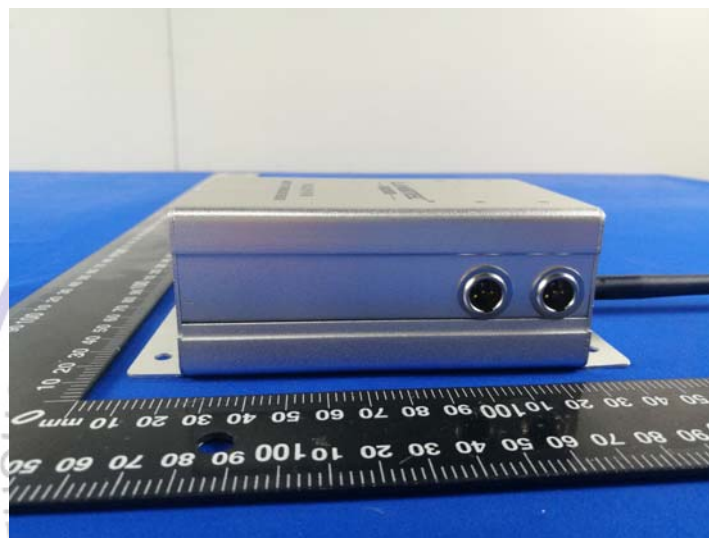
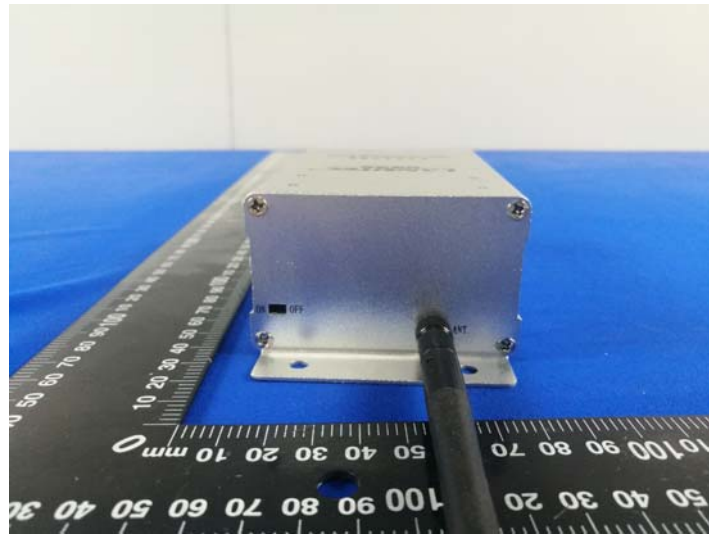

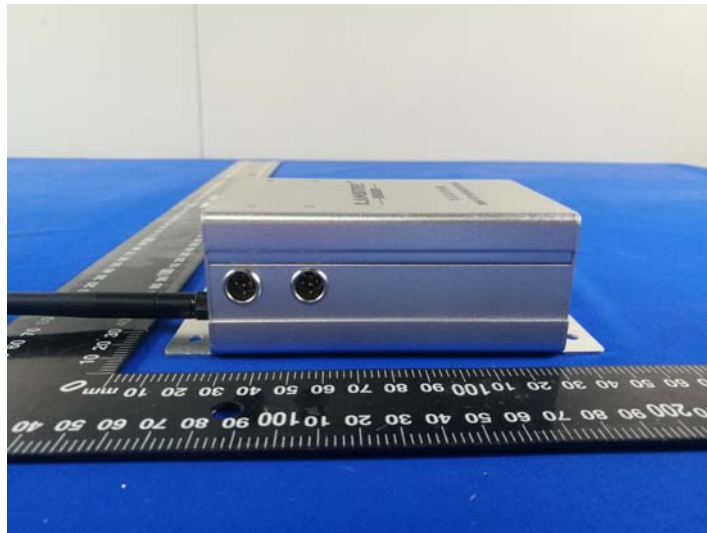

Internal Photos of EUT

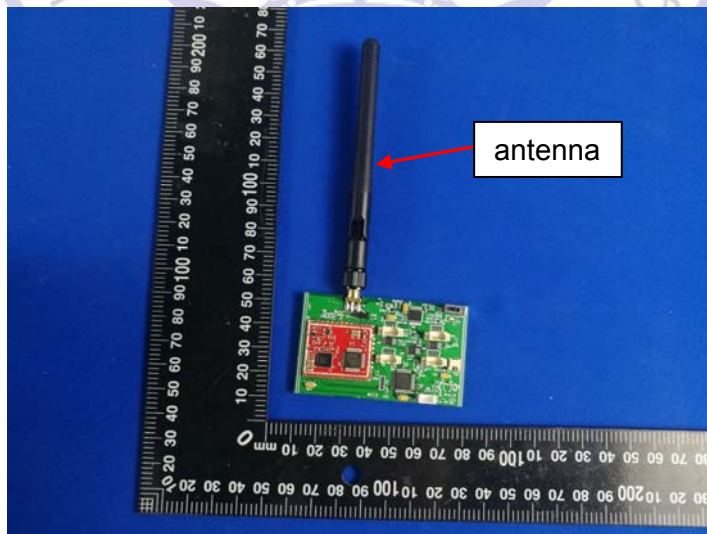

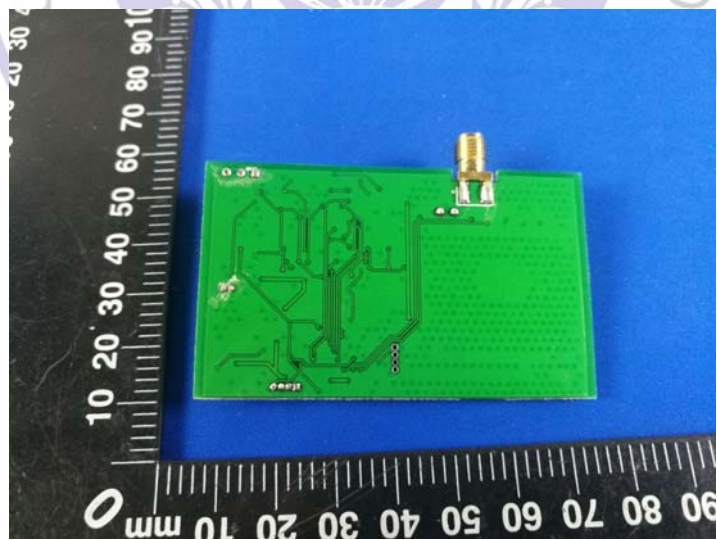
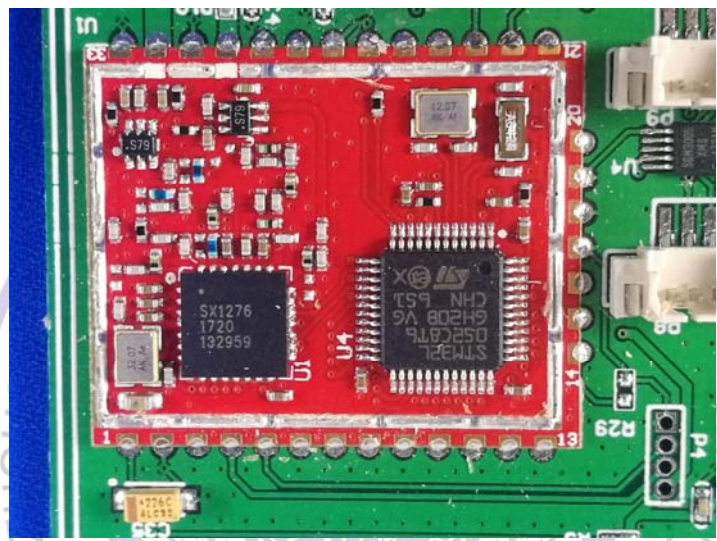
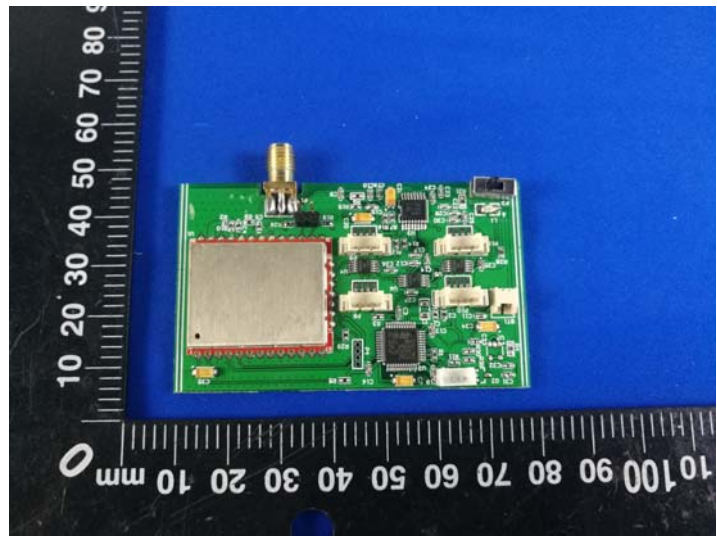

***** End of Report *****