



Test Report No.: RF180205W003-6

FCC TEST REPORT (PART 27)

Applicant:	Gosuncn Technology Group Co., Ltd.
Address:	6F, 2819 KaiChuang Blvd., Science Town, Huangpu District, Guangzhou City, Guangdong, China.

Manufacturer or Supplier:	Gosuncn Technology Group Co., Ltd.
Address:	6F, 2819 KaiChuang Blvd., Science Town, Huangpu District, Guangzhou City, Guangdong, China.
Product:	LTE OBDII Hotspot
Brand Name:	GOSUNCN
Model Name:	GD500
FCC ID:	2APNR-GD500
Date of tests:	Aug. 01, 2018 ~ Aug. 22, 2018

The tests have been carried out according to the requirements of the following standard:

- FCC Part 27, Subpart C, N ANSI/TIA/EIA-603- D
- FCC Part 2 ANSI/TIA/EIA-603-E ANSI C63.26-2015

CONCLUSION: The submitted sample was found to COMPLY with the test requirement

Prepared by Roger Li Engineer / Mobile Department	Approved by Sam Tung Manager / Mobile Department
 Date: Aug. 23, 2018	 Date: Aug. 23, 2018

This report is governed by, and incorporates by reference, CPS Conditions of Service as posted at the date of issuance of this report at <http://www.bureauveritas.com/home/about-us/our-business/cps/about-us/terms-conditions> and is intended for your exclusive use. Any copying or replication of this report to or for any other person or entity, or use of our name or trademark, is permitted only with our prior written permission. This report sets forth our findings solely with respect to the test samples identified herein. The results set forth in this report are not indicative or representative of the quality or characteristics of the lot from which a test sample was taken or any similar or identical product unless specifically and expressly noted. Our report includes all of the tests requested by you and the results thereof based upon the information that you provided to us. Measurement uncertainty is only provided upon request for accredited tests. You have 60 days from date of issuance of this report to notify us of any material error or omission caused by our negligence or if you require measurement uncertainty; provided, however, that such notice shall be in writing and shall specifically address the issue you wish to raise. A failure to raise such issue within the prescribed time shall constitute your unqualified acceptance of the completeness of this report, the tests conducted and the correctness of the report contents.



TABLE OF CONTENTS

RELEASE CONTROL RECORD	4
1 SUMMARY OF TEST RESULTS	5
1.1 MEASUREMENT UNCERTAINTY	5
1.2 TEST SITE AND INSTRUMENTS	7
2 GENERAL INFORMATION.....	9
2.1 GENERAL DESCRIPTION OF EUT.....	9
2.2 CONFIGURATION OF SYSTEM UNDER TEST	11
2.3 DESCRIPTION OF SUPPORT UNITS	12
2.4 DESCRIPTION OF TEST MODES.....	12
2.5 GENERAL DESCRIPTION OF APPLIED STANDARDS.....	15
3 TEST TYPES AND RESULTS	16
3.1 OUTPUT POWER MEASUREMENT	16
3.1.1 LIMITS OF OUTPUT POWER MEASUREMENT	16
3.1.2 TEST PROCEDURES	16
3.1.3 TEST SETUP.....	17
3.1.4 TEST RESULTS	18
3.2 FREQUENCY STABILITY MEASUREMENT	23
3.2.1 LIMITS OF FREQUENCY STABILITY MEASUREMENT	23
3.2.2 TEST PROCEDURE	23
3.2.3 TEST SETUP.....	23
3.2.4 TEST RESULTS	24
3.3 OCCUPIED BANDWIDTH MEASUREMENT	28
3.3.1 LIMITS OF OCCUPIED BANDWIDTH MEASUREMENT	28
3.3.2 TEST SETUP.....	28
3.3.3 TEST PROCEDURES	28
3.3.4 TEST RESULTS	29
3.4 PEAK TO AVERAGE RATIO	33
3.4.1 LIMITS OF PEAK TO AVERAGE RATIO MEASUREMENT.....	33
3.4.2 TEST SETUP.....	33
3.4.3 TEST PROCEDURES	33
3.4.4 TEST RESULTS	34
3.5 BAND EDGE MEASUREMENT	36
3.5.1 LIMITS OF BAND EDGE MEASUREMENT	36
3.5.2 TEST SETUP.....	36
3.5.3 TEST PROCEDURES	37
3.5.4 TEST RESULTS	38
3.6 CONDUCTED SPURIOUS EMISSIONS.....	42
3.6.1 LIMITS OF CONDUCTED SPURIOUS EMISSIONS MEASUREMENT	42
3.6.2 TEST PROCEDURE	42
3.6.3 TEST SETUP.....	42
3.6.4 TEST RESULTS	43
3.7 RADIATED EMISSION MEASUREMENT.....	47
3.7.1 LIMITS OF RADIATED EMISSION MEASUREMENT	47
3.7.2 TEST PROCEDURES	47
3.7.3 DEVIATION FROM TEST STANDARD	47
3.7.4 TEST SETUP.....	48
3.7.5 TEST RESULTS	50



Test Report No.: RF180205W003-6

4	INFORMATION ON THE TESTING LABORATORIES	62
5	APPENDIX A – MODIFICATIONS RECORDERS FOR ENGINEERING CHANGES TO THE EUT BY THE LAB	63



Test Report No.: RF180205W003-6

RELEASE CONTROL RECORD

ISSUE NO.	REASON FOR CHANGE	DATE ISSUED
RF180205W003-6	Original release	Aug. 23, 2018



Test Report No.: RF180523W002-7

1 SUMMARY OF TEST RESULTS

The EUT has been tested according to the following specifications:

APPLIED STANDARD: FCC Part 27 & Part 2				
STANDARD SECTION	TEST TYPE AND LIMIT	RESULT	REMARK	TEST LAB*
2.1046 27.50(c)(10)	Maximum Peak Output Power	PASS	Meet the requirement of limit.	B
2.1055 27.54	Frequency Stability	PASS	Meet the requirement of limit.	A
2.1049 27.53(g)	Occupied Bandwidth	PASS	Meet the requirement of limit.	A
27.50(d)(5)	Peak to average ratio	PASS	Meet the requirement of limit.	A
27.53(g)	Band Edge Measurements	PASS	Meet the requirement of limit.	A
2.1051 27.53(g)	Conducted Spurious Emissions	PASS	Meet the requirement of limit.	A
2.1053 27.53(g)	Radiated Spurious Emissions	PASS	Meet the requirement of limit. Minimum passing margin is -23.75dB at 32.43MHz.	B

*Test Lab Information Reference

Lab A:

BV 7Layers Communications Technology (Shenzhen) Co. Ltd

Lab Address:

No.B102, Dazu Chuangxin Mansion, North of Beihuan Avenue, North Area, Hi-Tech Industrial Park, Nanshan District, Shenzhen, Guangdong, China

Accredited Test Lab Cert 3939.01

Lab B:

Bureau Veritas Consumer Products Services (H.K.) Ltd., Taoyuan Branch

Lab Address:

No. 47-2, 14th Ling, Chia Pau Vil., Lin Kou Dist., New Taipei City, Taiwan, R.O.C.

FCC Registration/Designation Number: 788550/TW0003



1.1 MEASUREMENT UNCERTAINTY

Where relevant, the following measurement uncertainty levels have been estimated for tests performed on the EUT as specified in CISPR 16-4-2:

MEASUREMENT	FREQUENCY	UNCERTAINTY
Conducted emissions	9kHz~30MHz	2.66dB
Radiated emissions	9KHz ~ 30MHz	2.68dB
	30MHz ~ 1GMHz	3.26dB
	1GHz ~ 18GHz	4.48dB
	18GHz ~ 40GHz	4.12dB

This uncertainty represents an expanded uncertainty expressed at approximately the 95% confidence level using a coverage factor of k=2.



1.2 TEST SITE AND INSTRUMENTS

Equipment	Manufacturer	Model No.	Serial No.	Last Cal.	Next Cal.
MXE EMI Receiver	KEYSIGHT	N9038A-544	MY54450026	Mar. 16,18	Mar. 15,19
EXA Signal Analyzer	KEYSIGHT	N9010A-526	MY54510322	Mar. 16,18	Mar. 15,19
Bilog Antenna 1	ETS-LINDGREN	3143B	00161964	Nov. 26,16	Nov. 25,18
Bilog Antenna 2	ETS-LINDGREN	3143B	00161965	Nov. 26,16	Nov. 25,18
Horn Antenna 1	ETS-LINDGREN	3117	00168728	Nov. 26,16	Nov. 25,18
Horn Antenna 2	ETS-LINDGREN	3117	00168692	Nov. 26,16	Nov. 25,18
Loop antenna	Daze	ZN30900A	0708	Nov. 20,17	Nov. 19,18
Horn Antenna (18GHz-40GHz)	N/A	QWH-SL-18-40-K-SG/QMS-00361	15433	Dec. 16,16	Dec. 15,18
Radio Communication Analyzer	ANRITSU	MT8820C	6201465426	Mar. 02,18	Mar. 01,19
Signal Pre-Amplifier	EMSI	EMC 9135	980249	Jul. 09,18	Jul. 08,19
Signal Pre-Amplifier	EMSI	EMC 012645B	980257	Jul. 09,18	Jul. 08,19
Signal Pre-Amplifier	EMSI	EMC 184045B	980259	Jul. 09,18	Jul. 08,19
3m Semi-anechoic Chamber	ETS-LINDGREN	9m*6m*6m	Euroshieldpn-CT0001143-1216	Apr. 21,18	Apr. 20,19
Test Software	E3	V 9.160323	N/A	N/A	N/A
Test Software	ADT	ADT_Radiated_V7.6.15.9.2	N/A	N/A	N/A
10dB Attenuator	JFW/USA	50HF-010-SMA	1505	Jul. 09,18	Jul. 08,19
Power Meter	Anritsu	ML2495A	1506002	Mar. 02,18	Mar. 01,19
Power Sensor	Anritsu	MA2411B	1339352	Mar. 16,18	Mar. 15,19
Humid & Temp Programmable Tester	Juyi	ITH-120-45-CP-AR	IAA1504-001	Jul. 09,18	Jul. 08,19
MXG Analog Microwave Signal Generator	KEYSIGHT	N5183A	MY50143024	Mar. 13,18	Mar. 12,19

- NOTE:**
1. The calibration interval of the above test instruments is 12 months or 24 months and the calibrations are traceable to CEPREI/CHINA, GRGT/CHINA and NIM/CHINA.
 2. The test was performed in 3m Semi-anechoic Chamber and RF Oven Room.
 3. The horn antenna is used only for the measurement of emission frequency above 1GHz if tested.
 4. The FCC Site Registration No. is 525120.



Test Report No.: RF180523W002-7

- NOTE:**
1. The calibration interval of the above test instruments is 12 months and the calibrations are traceable to NML/ROC and NIST/USA.
 2. The calibration interval of the loop antenna is 24 months and the calibrations are traceable to NML/ROC and NIST/USA.
 3. The test was performed in 3m Semi-anechoic Chamber and RF Oven Room.
 4. The FCC Site Registration No. is 788550.



2 GENERAL INFORMATION

2.1 GENERAL DESCRIPTION OF EUT

PRODUCT	LTE OBDII Hotspot	
MODEL NAME	GD500	
POWER SUPPLY	12/24Vdc (adapter or host equipment) 3.7Vdc (Li-ion, battery)	
MODULATION TECHNOLOGY	LTE	QPSK, 16QAM
FREQUENCY RANGE	LTE Band 71 Channel Bandwidth: 5MHz	665.5MHz ~ 695.5MHz
	LTE Band 71 Channel Bandwidth: 10MHz	668MHz ~ 693MHz
	LTE Band 71 Channel Bandwidth: 15MHz	670.5MHz ~ 690.5MHz
	LTE Band 71 Channel Bandwidth: 20MHz	673MHz ~ 688MHz
EMISSION DESIGNATOR	LTE Band 71 Channel Bandwidth: 5MHz	QPSK: 4M49G7D
		16QAM: 4M47W7D
	LTE Band 71 Channel Bandwidth: 10MHz	QPSK: 8M94G7D
		16QAM: 8M93W7D
	LTE Band 71 Channel Bandwidth: 15MHz	QPSK: 13M4G7D
		16QAM: 13M4W7D
	LTE Band 71 Channel Bandwidth: 20MHz	QPSK: 17M9G7D
		16QAM: 17M9W7D
MAX. ERP/EIRP POWER	LTE Band 71 Channel Bandwidth: 5MHz	190mW
	LTE Band 71 Channel Bandwidth: 10MHz	228mW
	LTE Band 71 Channel Bandwidth: 15MHz	242mW
	LTE Band 71 Channel Bandwidth: 20MHz	248mW
ANTENNA TYPE	Fixed Internal Antenna with -0.2dBi	
HW VERSION	SD6500.H03	
SW VERSION	EN_SD6500V1.0.0B01	
ACCESSORY DEVICE	Refer to note as below	
DATA CABLE	N/A	



Test Report No.: RF180523W002-7

NOTE:

1. For a more detailed features description, please refer to the manufacturer's specifications or the user's manual.
2. There were two configurations for this project:

EUT	Configurations
EUT 1	SIM
EUT 2	E-SIM + Battery

3. For the test results, the EUT had been tested with all conditions. But only the worst case was shown in test report.

2.2 CONFIGURATION OF SYSTEM UNDER TEST

FOR RADIATION EMISSION TEST

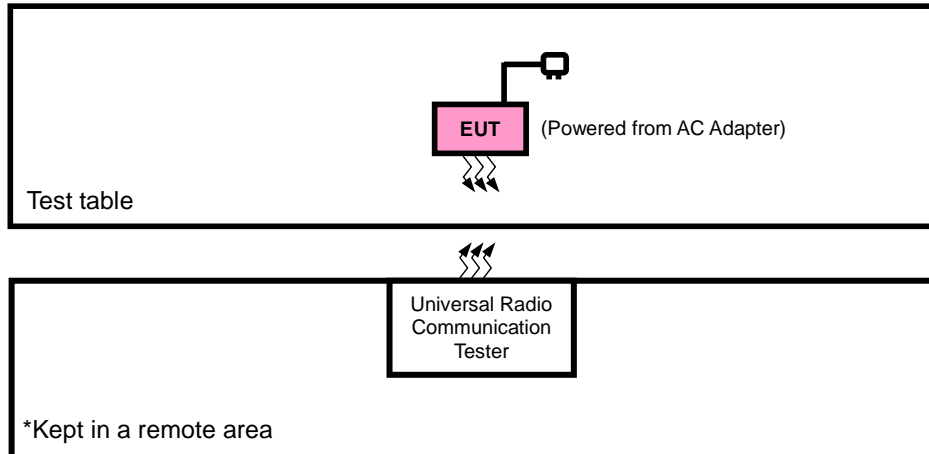

FOR CONDUCTED & E.I.R.P TEST

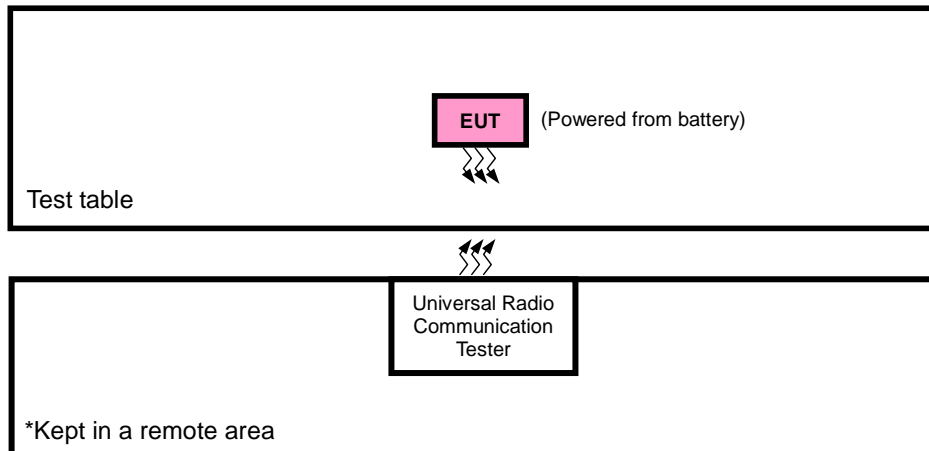



2.3 DESCRIPTION OF SUPPORT UNITS

The EUT has been tested as an independent unit together with other necessary accessories or support units. The following support units or accessories were used to form a representative test configuration during the tests.

NO.	PRODUCT	BRAND	MODEL NO.	SERIAL NO.	FCC ID
1	DC source	LONG WEI	PS-6403D	010934269	N/A
2	PC	HP	A6608CN	3CR83825X3	N/A

NO.	SIGNAL CABLE DESCRIPTION OF THE ABOVE SUPPORT UNITS
1	DC Line: Unshielded, Detachable 1.0m
2	AC Line: Unshielded, Detachable 1.5m

NOTE:

- 1. All power cords of the above support units are non shielded (1.8m).

2.4 DESCRIPTION OF TEST MODES

Pre-Scan has been conducted to determine the worst-case mode from all possible combinations between available modulations, data rates, XYZ axis and antenna ports. The worst case in ERP/EIRP and radiated emission was found when positioned on X-plane for LTE. Following channel(s) was (were) selected for the final test as listed below:

EUT CONFIGURE MODE	DESCRIPTION
A	EUT + Adapter + USB Cable + with LTE link
B	EUT + Battery with LTE link



Test Report No.: RF180523W002-7

LTE BAND 71

EUT CONFIGURE MODE	TEST ITEM	AVAILABLE CHANNEL	TESTED CHANNEL	CHANNEL BANDWIDTH	MODULATION	MODE
B	EIRP	133147 to 133447	133147, 133297, 133447	5MHz	QPSK, 16QAM	1 RB / 0 RB Offset
		133172 to 133422	133172, 133297, 133422	10MHz	QPSK, 16QAM	1 RB / 0 RB Offset
		133197 to 133397	133197, 133297, 133397	15MHz	QPSK, 16QAM	1 RB / 0 RB Offset
		133222 to 133372	133222, 133297, 133372	20MHz	QPSK, 16QAM	1 RB / 0 RB Offset
B	FREQUENCY STABILITY	133147 to 133447	133147 133447	5MHz	QPSK	1 RB / 0 RB Offset
		133172 to 133422	133172 133422	10MHz	QPSK	1 RB / 0 RB Offset
		133197 to 133397	133197 133397	15MHz	QPSK	1 RB / 0 RB Offset
		133222 to 133372	133222 133372	20MHz	QPSK	1 RB / 0 RB Offset
B	OCCUPIED BANDWIDTH	133147 to 133447	133147, 133297, 133447	5MHz	QPSK, 16QAM	6 RB / 0 RB Offset
		133172 to 133422	133172, 133297, 133422	10MHz	QPSK, 16QAM	15 RB / 0 RB Offset
		133197 to 133397	133197, 133297, 133397	15MHz	QPSK, 16QAM	25 RB / 0 RB Offset
		133222 to 133372	133222, 133297, 133372	20MHz	QPSK, 16QAM	50 RB / 0 RB Offset
B	PEAK TO AVERAGE RATIO	133147 to 133447	133147, 133297, 133447	5MHz	QPSK, 16QAM	1 RB / 0 RB Offset
		133172 to 133422	133172, 133297, 133422	10MHz	QPSK, 16QAM	1 RB / 0 RB Offset
		133197 to 133397	133197, 133297, 133397	15MHz	QPSK, 16QAM	1 RB / 0 RB Offset
		133222 to 133372	133222, 133297, 133372	20MHz	QPSK, 16QAM	1 RB / 0 RB Offset
B	BAND EDGE	133147 to 133447	133147	5MHz	QPSK	1 RB / 0 RB Offset 6 RB / 0 RB Offset
			133447	5MHz	QPSK	1 RB / 5 RB Offset 6 RB / 0 RB Offset
		133172 to 133422	133172	10MHz	QPSK	1 RB / 0 RB Offset 15 RB / 0 RB Offset
			1334227	10MHz	QPSK	1 RB / 14 RB Offset 15 RB / 0 RB Offset
		133197 to 133397	133197	15MHz	QPSK	1 RB / 0 RB Offset 25 RB / 0 RB Offset
			133397	15MHz	QPSK	1 RB / 24 RB Offset 25 RB / 0 RB Offset
		133222 to 133372	133222	20MHz	QPSK	1 RB / 0 RB Offset 50 RB / 0 RB Offset
			133372	20MHz	QPSK	1 RB / 49 RB Offset 50 RB / 0 RB Offset



Test Report No.: RF180523W002-7

B	CONDCUDET ED EMISSION	133147 to 133447	133147, 133297, 133447	5MHz	QPSK	1 RB / 0 RB Offset
		133172 to 133422	133172, 133297, 133422	10MHz	QPSK	1 RB / 0 RB Offset
		133197 to 133397	133197, 133297, 133397	15MHz	QPSK	1 RB / 0 RB Offset
		133222 to 133372	133222, 133297, 133372	20MHz	QPSK	1 RB / 0 RB Offset
A	RADIATED EMISSION	131979 to 132665	133147, 133297, 133447	5MHz	QPSK	1 RB / 0 RB Offset
		133172 to 133442	133172, 133297, 133442	20MHz	QPSK	1 RB / 0 RB Offset

Note: This device was tested under all bandwidths, RB configurations and modulations. The worst case was found in QPSK modulation.

TEST CONDITION:

TEST ITEM	ENVIRONMENTAL CONDITIONS	INPUT POWER	TESTED BY
EIRP(ERP)	24deg. C, 60%RH	DC 12V from adaptor	Getaz Yang
FREQUENCY STABILITY	24deg. C, 61%RH	DC 12V from adaptor	Bert Ma
OCCUPIED BANDWIDTH	24deg. C, 61%RH	DC 12V from adaptor	Bert Ma
PEAK TO AVERAGE RATIO	24deg. C, 61%RH	DC 12V from adaptor	Bert Ma
BAND EDGE	24deg. C, 61%RH	DC 12V from adaptor	Bert Ma
CONDCUDETED EMISSION	24deg. C, 61%RH	DC 12V from adaptor	Bert Ma
RADIATED EMISSION	24deg. C, 60%RH	DC 12V from adaptor	Getaz Yang



Test Report No.: RF180523W002-7

2.5 GENERAL DESCRIPTION OF APPLIED STANDARDS

The EUT is a RF product. According to the specifications of the manufacturer, it must comply with the requirements of the following standards:

FCC 47 CFR Part 2

FCC 47 CFR Part 27

KDB 971168 D01 Power Meas License Digital Systems v03r01

ANSI/TIA/EIA-603-D

ANSI/TIA/EIA-603-E

ANSI C63.26-2015

NOTE: All test items have been performed and recorded as per the above standards.



3 TEST TYPES AND RESULTS

3.1 OUTPUT POWER MEASUREMENT

3.1.1 LIMITS OF OUTPUT POWER MEASUREMENT

Portable stations (hand-held devices) in the 600 MHz uplink band and the 698-746 MHz band, and fixed and mobile stations in the 600 MHz uplink band are limited to 3 watts ERP

3.1.2 TEST PROCEDURES

EIRP / ERP MEASUREMENT:

- a. The EUT was set up for the maximum power with LTE link data modulation. The power was measured with R&S Spectrum Analyzer. All measurements were done at 3 channels (low, middle and high operational frequency range). RBW and VBW is 10MHz for LTE.
- b. E.I.R.P power measurement. In the semi-anechoic chamber, EUT placed on the 0.8m height of Turn Table, rotated the table around 360 degrees to search the maximum radiation power and receiver antenna shall be rotated vertical and horizontal polarization and moved height from 1m to 4m to find the maximum polar radiated power. The "Read Value" is the spectrum reading the maximum power value.
- c. The substitution horn antenna is substituted for EUT at the same position and signals generator export the CW signal to the substitution antenna via a TX cable. Rotated the Turn Table and moved receiving antenna to find the maximum radiation power. Adjust output power level of S.G to get a Value of spectrum reading equal to "Read Value" of step a. Record the power level of S.G
- d. $EIRP = \text{Output power level of S.G} - \text{TX cable loss} + \text{Antenna gain of substitution horn}$
- e. $E.R.P = E.I.R.P - 2.15 \text{ dB}$

CONDUCTED POWER MEASUREMENT:

- a. The EUT was set up for the maximum power with LTE link data modulation and link up with simulator.
- b. Set the EUT to transmit under low, middle and high channel and record the power level shown on simulator.

3.1.3 TEST SETUP

ERP MEASUREMENT:

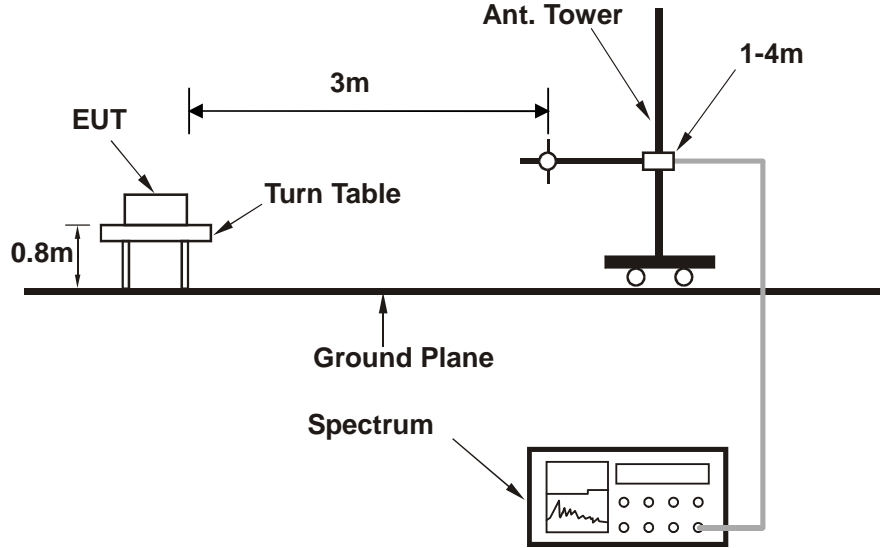

EIRP MEASUREMENT:

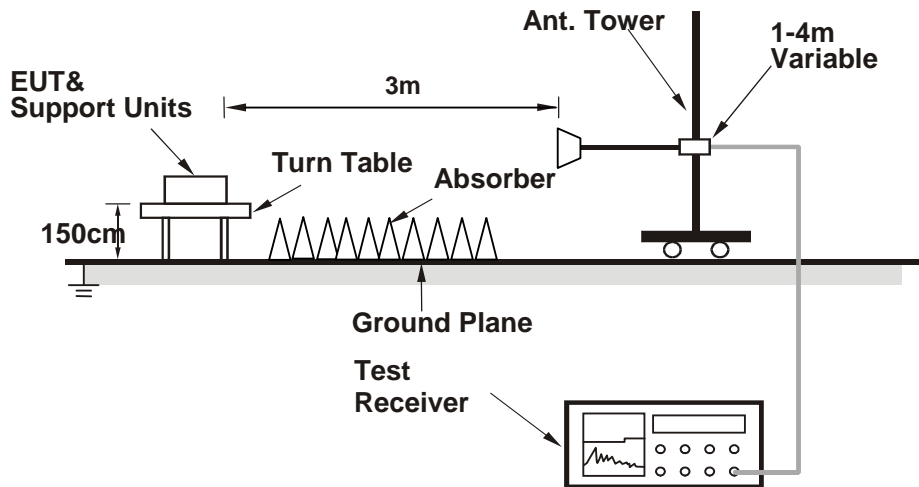

For the actual test configuration, please refer to the attached file (Test Setup Photo).

CONDUCTED POWER MEASUREMENT:

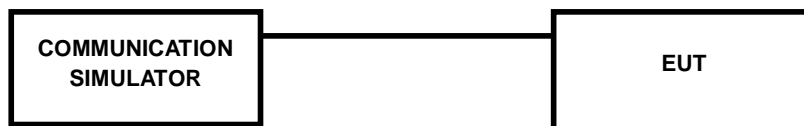

For the actual test configuration, please refer to the attached file (Test Setup Photo).



3.1.4 TEST RESULTS

AVERAGE CONDUCTED OUTPUT POWER (dBm)

LTE Band 71							
BW	Modulation	RB Size	RB Offset	Low CH 133147	Mid CH 133297	High CH 133447	MPR
				Frequency 665.5 MHz	Frequency 680.5 MHz	Frequency 695.5 MHz	
5 MHz	QPSK	1	0	23.99	24.05	24.02	0
		1	12	23.79	23.85	23.82	0
		1	24	23.73	23.79	23.76	0
		12	0	22.77	22.83	22.80	1
		12	6	22.68	22.74	22.71	1
		12	13	22.63	22.69	22.66	1
		25	0	22.68	22.74	22.71	1
	16QAM	1	0	23.29	23.35	23.32	1
		1	12	23.25	23.31	23.28	1
		1	24	23.21	23.27	23.24	1
		12	0	22.19	22.25	22.22	2
		12	6	22.25	22.31	22.28	2
		12	13	22.22	22.28	22.25	2
		25	0	22.16	22.22	22.19	2
BW	Modulation	RB Size	RB Offset	Low CH 133172	Mid CH 133297	High CH 133442	MPR
				Frequency 668 MHz	Frequency 680.5 MHz	Frequency 693 MHz	
10 MHz	QPSK	1	0	24.01	24.07	24.04	0
		1	24	23.81	23.87	23.84	0
		1	49	23.75	23.81	23.78	0
		25	0	22.79	22.85	22.82	1
		25	12	22.70	22.76	22.73	1
		25	25	22.65	22.71	22.68	1
		50	0	22.70	22.76	22.73	1
	16QAM	1	0	23.31	23.37	23.34	1
		1	24	23.27	23.33	23.30	1
		1	49	23.23	23.29	23.26	1
		25	0	22.21	22.27	22.24	2
		25	12	22.27	22.33	22.30	2
		25	25	22.24	22.30	22.27	2
		50	0	22.18	22.24	22.21	2



Test Report No.: RF180523W002-7

LTE Band 71							
BW	Modulation	RB Size	RB Offset	Low CH 133197	Mid CH 133297	High CH 133397	MPR
				Frequency 670.5 MHz	Frequency 680.5 MHz	Frequency 690.5 MHz	
15 MHz	QPSK	1	0	24.04	24.10	24.07	0
		1	37	23.84	23.90	23.87	0
		1	74	23.78	23.84	23.81	0
		36	0	22.82	22.88	22.85	1
		36	19	22.73	22.79	22.76	1
		36	39	22.68	22.74	22.71	1
		75	0	22.73	22.79	22.76	1
	16QAM	1	0	23.34	23.40	23.37	1
		1	37	23.30	23.36	23.33	1
		1	74	23.26	23.32	23.29	1
		36	0	22.24	22.30	22.27	2
		36	19	22.30	22.36	22.33	2
		36	39	22.27	22.33	22.30	2
		75	0	22.21	22.27	22.24	2
BW	Modulation	RB Size	RB Offset	Low CH 133222	Mid CH 133297	High CH 133372	MPR
				Frequency 673 MHz	Frequency 680.5 MHz	Frequency 688 MHz	
20 MHz	QPSK	1	0	24.09	24.15	24.12	0
		1	50	23.89	23.95	23.92	0
		1	99	23.83	23.89	23.86	0
		50	0	22.87	22.93	22.90	1
		50	25	22.78	22.84	22.81	1
		50	50	22.73	22.79	22.76	1
		100	0	22.78	22.84	22.81	1
	16QAM	1	0	23.39	23.45	23.42	1
		1	50	23.35	23.41	23.38	1
		1	99	23.31	23.37	23.34	1
		50	0	22.29	22.35	22.32	2
		50	25	22.35	22.41	22.38	2
		50	50	22.32	22.38	22.35	2
		100	0	22.26	22.32	22.29	2



Test Report No.: RF180523W002-7

EIRP

LTE BAND 71

CHANNEL BANDWIDTH: 5MHz QPSK

Channel	Frequency (MHz)	SPA LVL (dBm)	Correction Factor(dB)	EIRP(dBm)	EIRP(mW)	Polarization (H/V)	LIMIT (W)
133147	665.5	-5.43	30.36	22.78	189.67	H	3
133297	680.5	-5.35	30.17	22.67	184.93	H	3
133447	695.5	-5.57	30.17	22.45	175.79	H	3
133147	665.5	-13.07	32.03	16.81	47.97	V	3
133297	680.5	-13.22	31.98	16.61	45.81	V	3
133447	695.5	-13.48	32.06	16.43	43.95	V	3

CHANNEL BANDWIDTH: 5MHz 16QAM

Channel	Frequency (MHz)	SPA LVL (dBm)	Correction Factor(dB)	EIRP(dBm)	EIRP(mW)	Polarization (H/V)	LIMIT (W)
133147	665.5	-6.46	30.36	21.75	149.62	H	3
133297	680.5	-6.42	30.17	21.60	144.54	H	3
133447	695.5	-6.58	30.17	21.44	139.32	H	3
133147	665.5	-14.08	32.03	15.80	38.02	V	3
133297	680.5	-14.24	31.98	15.59	36.22	V	3
133447	695.5	-14.54	32.06	15.37	34.43	V	3

LTE BAND 71

CHANNEL BANDWIDTH: 10MHz QPSK

Channel	Frequency (MHz)	SPA LVL (dBm)	Correction Factor(dB)	EIRP(dBm)	EIRP(mW)	Polarization (H/V)	LIMIT (W)
133172	668	-4.44	30.17	23.58	228.03	H	3
133297	680.5	-4.63	30.17	23.39	218.27	H	3
133442	693	-4.83	30.18	23.20	208.93	H	3
133172	668	-12.14	31.96	17.67	58.48	V	3
133297	680.5	-12.33	31.98	17.50	56.23	V	3
133442	693	-12.72	32.03	17.16	52.00	V	3



Test Report No.: RF180523W002-7

CHANNEL BANDWIDTH: 10MHz 16QAM

Channel	Frequency (MHz)	SPA LVL (dBm)	Correction Factor(dB)	EIRP(dBm)	EIRP(mW)	Polarization (H/V)	LIMIT (W)
133172	668	-5.50	30.17	22.52	178.65	H	3
133297	680.5	-5.67	30.17	22.35	171.79	H	3
133442	693	-5.84	30.18	22.19	165.58	H	3
133172	668	-13.19	31.96	16.62	45.92	V	3
133297	680.5	-13.42	31.98	16.41	43.75	V	3
133442	693	-13.75	32.03	16.13	41.02	V	3

LTE BAND 71

CHANNEL BANDWIDTH: 15MHz QPSK

Channel	Frequency (MHz)	SPA LVL (dBm)	Correction Factor(dB)	EIRP(dBm)	EIRP(mW)	Polarization (H/V)	LIMIT (W)
133197	670.5	-4.19	30.17	23.83	241.55	H	3
133297	680.5	-4.42	30.17	23.60	229.09	H	3
133397	690.5	-4.61	30.18	23.42	219.79	H	3
133197	670.5	-11.98	31.96	17.83	60.67	V	3
133297	680.5	-12.18	31.98	17.65	58.21	V	3
133397	690.5	-12.48	32.03	17.40	54.95	V	3

CHANNEL BANDWIDTH: 15MHz 16QAM

Channel	Frequency (MHz)	SPA LVL (dBm)	Correction Factor(dB)	EIRP(dBm)	EIRP(mW)	Polarization (H/V)	LIMIT (W)
133197	670.5	-5.25	30.17	22.77	189.23	H	3
133297	680.5	-5.46	30.17	22.56	180.30	H	3
133397	690.5	-5.70	30.18	22.33	171.00	H	3
133197	670.5	-12.99	31.96	16.82	48.08	V	3
133297	680.5	-13.24	31.98	16.59	45.60	V	3
133397	690.5	-13.53	32.03	16.35	43.15	V	3



Test Report No.: RF180523W002-7

LTE BAND 71

CHANNEL BANDWIDTH: 20MHz QPSK

Channel	Frequency (MHz)	SPA LVL (dBm)	Correction Factor(dB)	EIRP(dBm)	EIRP(mW)	Polarization (H/V)	LIMIT (W)
133222	673	-4.08	30.17	23.94	247.74	H	3
133297	680.5	-4.28	30.17	23.74	236.59	H	3
133372	688	-4.48	30.18	23.55	226.46	H	3
133222	673	-11.87	31.96	17.94	62.23	V	3
133297	680.5	-12.11	31.98	17.72	59.16	V	3
133372	688	-12.33	32.03	17.55	56.89	V	3

CHANNEL BANDWIDTH: 20MHz 16QAM

Channel	Frequency (MHz)	SPA LVL (dBm)	Correction Factor(dB)	EIRP(dBm)	EIRP(mW)	Polarization (H/V)	LIMIT (W)
133222	673	-5.14	30.17	22.88	194.09	H	3
133297	680.5	-5.33	30.17	22.69	185.78	H	3
133372	688	-5.56	30.18	22.47	176.60	H	3
133222	673	-12.91	31.96	16.90	48.98	V	3
133297	680.5	-13.15	31.98	16.68	46.56	V	3
133372	688	-13.40	32.03	16.48	44.46	V	3

REMARKS: 1. EIRP Output Power (dBm) = SPA LVL (dBm) + Correction Factor (dB).
2. Correction factor (dB) = Free Space Loss + Antenna Factor + Cable Loss

Note: EIRP Power Test was performed by **Bureau Veritas Consumer Products Services (H.K.) Ltd., Taoyuan Branch**

3.2 FREQUENCY STABILITY MEASUREMENT

3.2.1 LIMITS OF FREQUENCY STABILITY MEASUREMENT

The frequency stability shall be sufficient to ensure that the fundamental emissions stay within the authorized bands of operation.

3.2.2 TEST PROCEDURE

- a. Device is placed at the oven room. The oven room could control the temperatures and humidity. Power warm up is at least 15 min and power applied should perform before recording frequency error.
- b. EUT is connected the external power supply to control the DC input power. The test voltage range is from minimum to maximum working voltage. Each step shall be record the frequency error rate.
- c. The temperature range step is 10 degrees in this test items. All temperature levels shall be hold the $\pm 0.5^{\circ}\text{C}$ during the measurement testing. The each temperature step shall be at least 0.5 hours, consider the EUT could be test under the stability condition.

NOTE: The frequency error was recorded frequency error from the communication simulator.

3.2.3 TEST SETUP

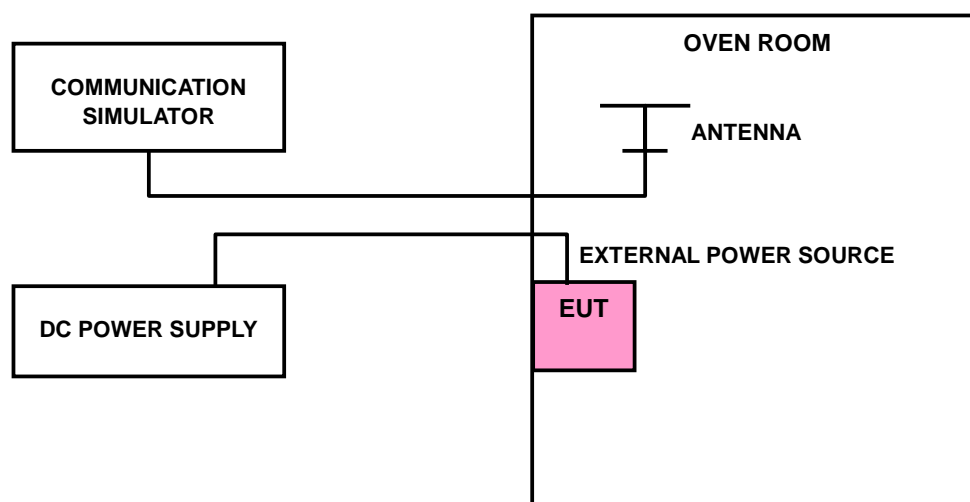



3.2.4 TEST RESULTS

LTE BAND 71

FREQUENCY ERROR VS. VOLTAGE

VOLTAGE (Volts)	5MHz		LIMIT (ppm)
	FREQUENCY ERROR (ppm)		
	Low Channel	High Channel	
12/24	0.0005	0.0005	2.5
9	-0.0007	-0.0006	2.5
32	0.0005	0.0005	2.5

NOTE: The applicant defined the normal working voltage of the battery is from 9Vdc to 32Vdc.

FREQUENCY ERROR vs. TEMPERATURE.

TEMP. (°C)	5MHz		LIMIT (ppm)
	FREQUENCY ERROR (ppm)		
	Low Channel	High Channel	
-30	-0.0038	-0.0038	2.5
-20	-0.0033	-0.0034	2.5
-10	-0.0029	-0.0029	2.5
0	-0.0027	-0.0027	2.5
10	-0.0021	-0.0021	2.5
20	-0.0017	-0.0017	2.5
30	-0.0013	-0.0013	2.5
40	-0.0008	-0.0008	2.5
50	-0.0003	-0.0003	2.5



Test Report No.: RF180523W002-7

FREQUENCY ERROR VS. VOLTAGE

VOLTAGE (Volts)	10MHz		LIMIT (ppm)
	FREQUENCY ERROR (ppm)		
	Low Channel	High Channel	
12/24	0.0006	0.0006	2.5
9	-0.0006	-0.0007	2.5
32	0.0006	0.0005	2.5

NOTE: The applicant defined the normal working voltage of the battery is from 9Vdc to 32Vdc.

FREQUENCY ERROR vs. TEMPERATURE.

TEMP. (°C)	10MHz		LIMIT (ppm)
	FREQUENCY ERROR (ppm)		
	Low Channel	High Channel	
-30	-0.0039	-0.0040	2.5
-20	-0.0034	-0.0034	2.5
-10	-0.0025	-0.0026	2.5
0	-0.0021	-0.0021	2.5
10	-0.0019	-0.0019	2.5
20	-0.0013	-0.0013	2.5
30	-0.0011	-0.0011	2.5
40	-0.0006	-0.0006	2.5
50	-0.0004	-0.0004	2.5



Test Report No.: RF180523W002-7

FREQUENCY ERROR VS. VOLTAGE

VOLTAGE (Volts)	15MHz		LIMIT (ppm)
	FREQUENCY ERROR (ppm)		
	Low Channel	High Channel	
12/24	0.0006	0.0006	2.5
9	-0.0007	-0.0006	2.5
32	0.0005	0.0005	2.5

NOTE: The applicant defined the normal working voltage of the battery is from 9Vdc to 32Vdc.

FREQUENCY ERROR vs. TEMPERATURE.

TEMP. (°C)	15MHz		LIMIT (ppm)
	FREQUENCY ERROR (ppm)		
	Low Channel	High Channel	
-30	-0.0041	-0.0041	2.5
-20	-0.0038	-0.0039	2.5
-10	-0.0030	-0.0030	2.5
0	-0.0026	-0.0026	2.5
10	-0.0021	-0.0021	2.5
20	-0.0017	-0.0017	2.5
30	-0.0011	-0.0011	2.5
40	-0.0006	-0.0006	2.5
50	-0.0001	-0.0001	2.5



Test Report No.: RF180523W002-7

FREQUENCY ERROR VS. VOLTAGE

VOLTAGE (Volts)	20MHz		LIMIT (ppm)
	FREQUENCY ERROR (ppm)		
	Low Channel	High Channel	
12/24	0.0006	0.0005	2.5
9	-0.0005	-0.0006	2.5
32	0.0005	0.0005	2.5

NOTE: The applicant defined the normal working voltage of the battery is from 9Vdc to 32Vdc.

FREQUENCY ERROR vs. TEMPERATURE.

TEMP. (°C)	20MHz		LIMIT (ppm)
	FREQUENCY ERROR (ppm)		
	Low Channel	High Channel	
-30	-0.0042	-0.0043	2.5
-20	-0.0038	-0.0038	2.5
-10	-0.0032	-0.0033	2.5
0	-0.0030	-0.0031	2.5
10	-0.0021	-0.0021	2.5
20	-0.0017	-0.0018	2.5
30	-0.0013	-0.0013	2.5
40	-0.0011	-0.0011	2.5
50	-0.0003	-0.0003	2.5

3.3 OCCUPIED BANDWIDTH MEASUREMENT

3.3.1 LIMITS OF OCCUPIED BANDWIDTH MEASUREMENT

The width of a frequency band such that, below the lower and above the upper frequency limits, the mean powers emitted are each equal to a specified percentage 0.5 % of the total mean power of a given emission.

3.3.2 TEST SETUP

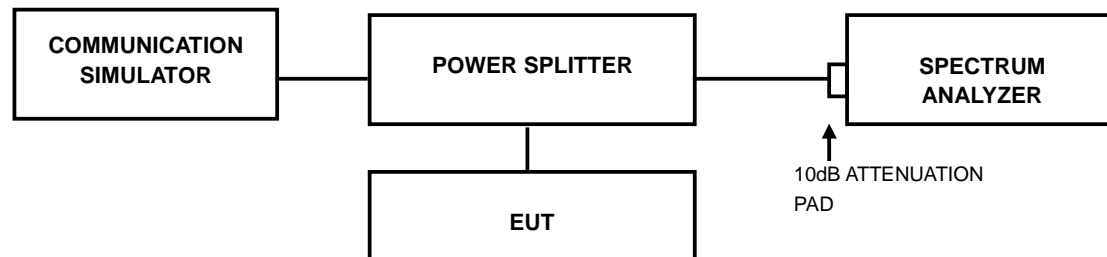

3.3.3 TEST PROCEDURES

- a. The conducted occupied bandwidth used the power splitter via EUT RF power connector between simulation base station and spectrum analyzer.
- b. Use OBW measurement function of Spectrum analyzer to measure 99 % occupied bandwidth.



3.3.4 TEST RESULTS

LTE BAND 71

Channel Bandwidth : 5MHz							
Channel	Frequency (MHz)	99% Occupied bandwidth (MHz)		Channel	Frequency (MHz)	26dB bandwidth (MHz)	
		QPSK	16QAM			QPSK	16QAM
133147	665.5	4.49	4.46	133147	665.5	4.93	4.88
133297	680.5	4.46	4.47	133297	680.5	4.92	4.93
133447	695.5	4.48	4.46	133447	695.5	4.90	4.88

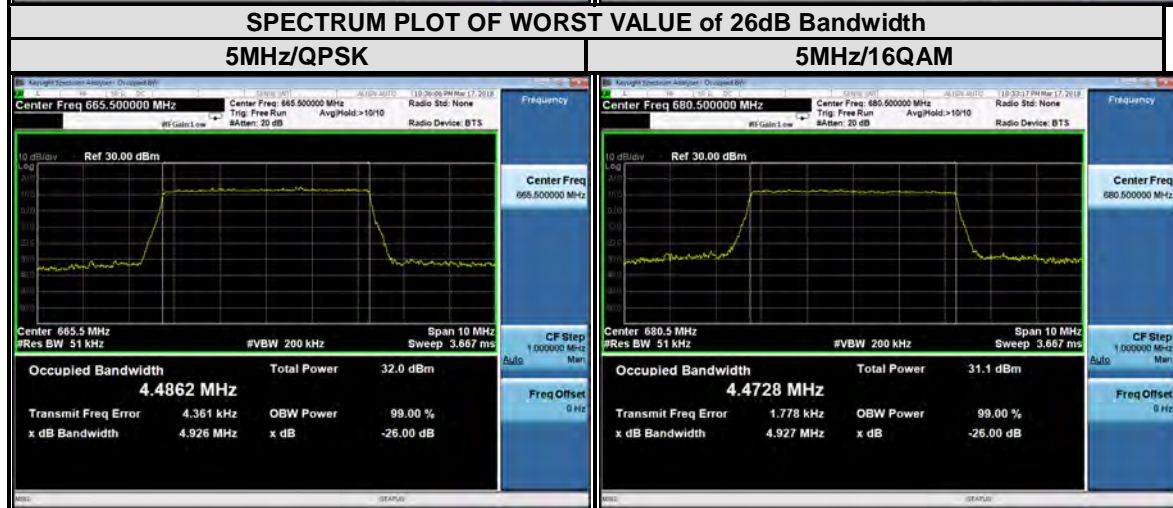
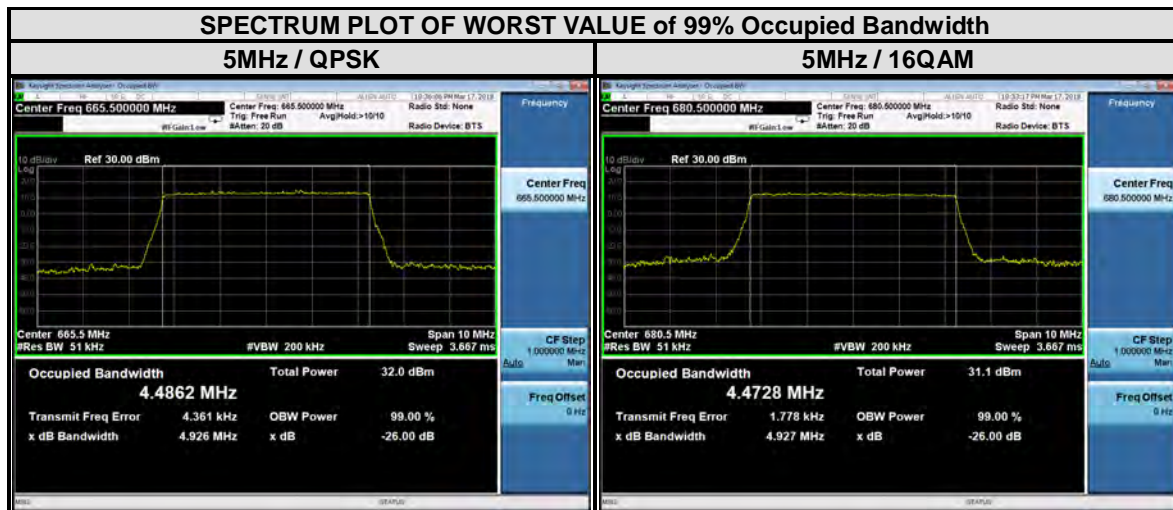



Test Report No.: RF180523W002-7

Channel Bandwidth : 10MHz							
Channel	Frequency (MHz)	99% Occupied bandwidth (MHz)		Channel	Frequency (MHz)	26dB bandwidth (MHz)	
		QPSK	16QAM			QPSK	16QAM
133172	1715	8.94	8.92	133172	1715	9.79	9.60
133297	680.5	8.94	8.93	133297	680.5	9.76	9.67
133442	1775	8.91	8.93	133442	1775	9.66	9.61

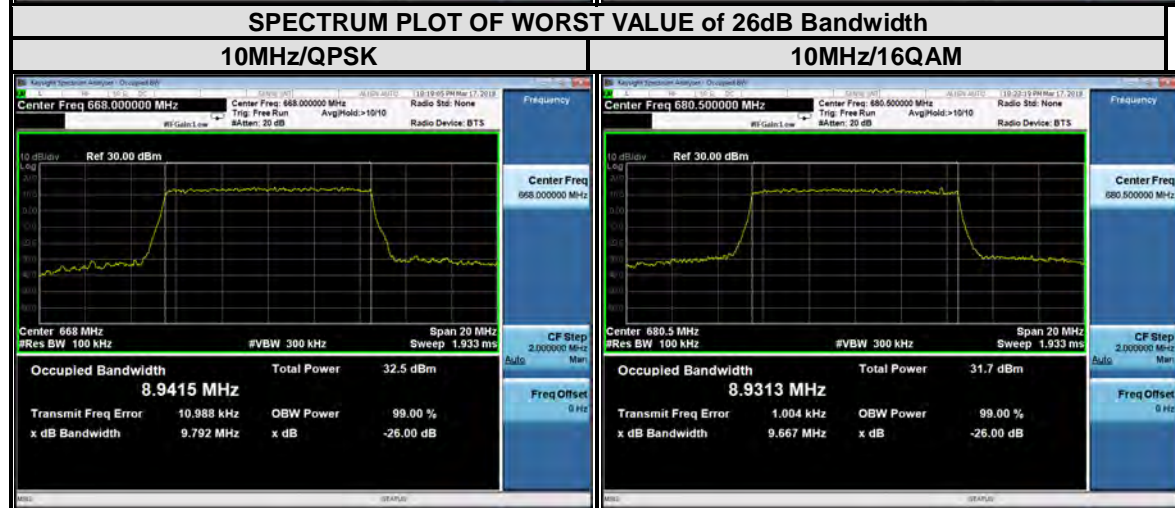
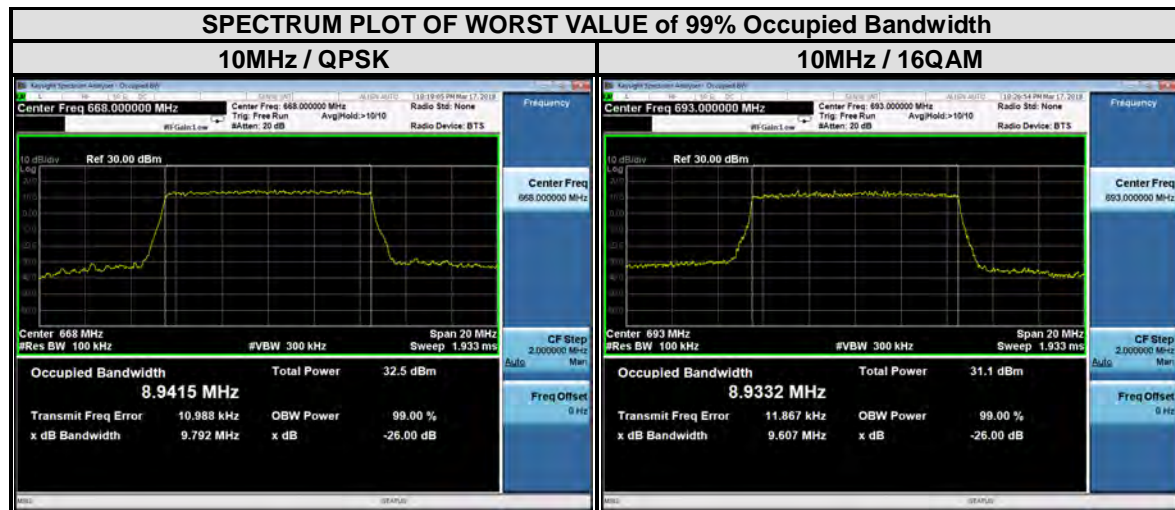



Test Report No.: RF180523W002-7

Channel Bandwidth : 15MHz							
Channel	Frequency (MHz)	99% Occupied bandwidth (MHz)		Channel	Frequency (MHz)	26dB bandwidth (MHz)	
		QPSK	16QAM			QPSK	16QAM
133197	670.5	13.39	13.42	133197	670.5	14.53	14.39
133297	680.5	13.36	13.38	133297	680.5	14.32	14.40
133397	690.5	13.41	13.42	133397	690.5	14.49	14.43

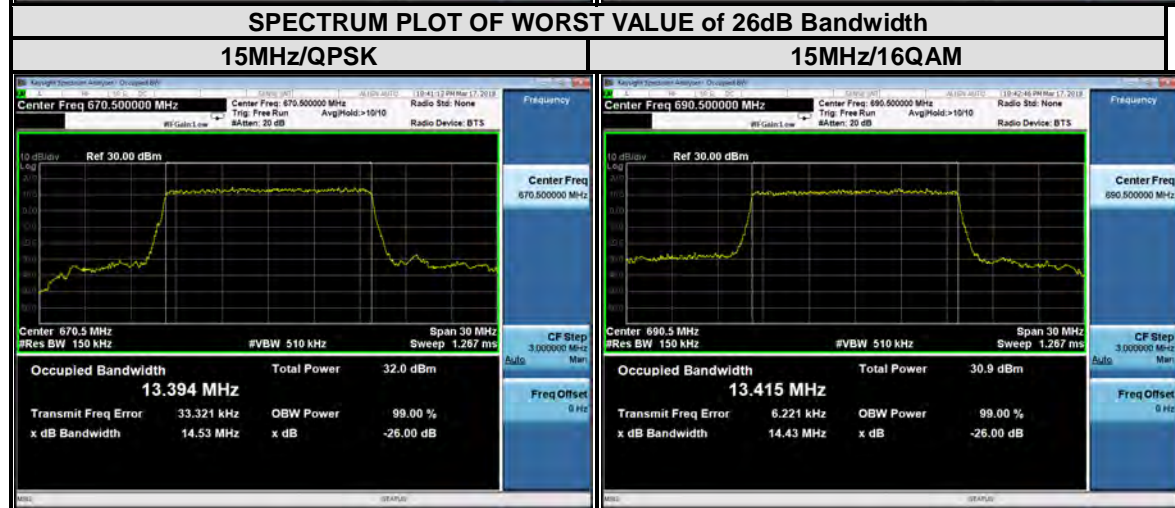
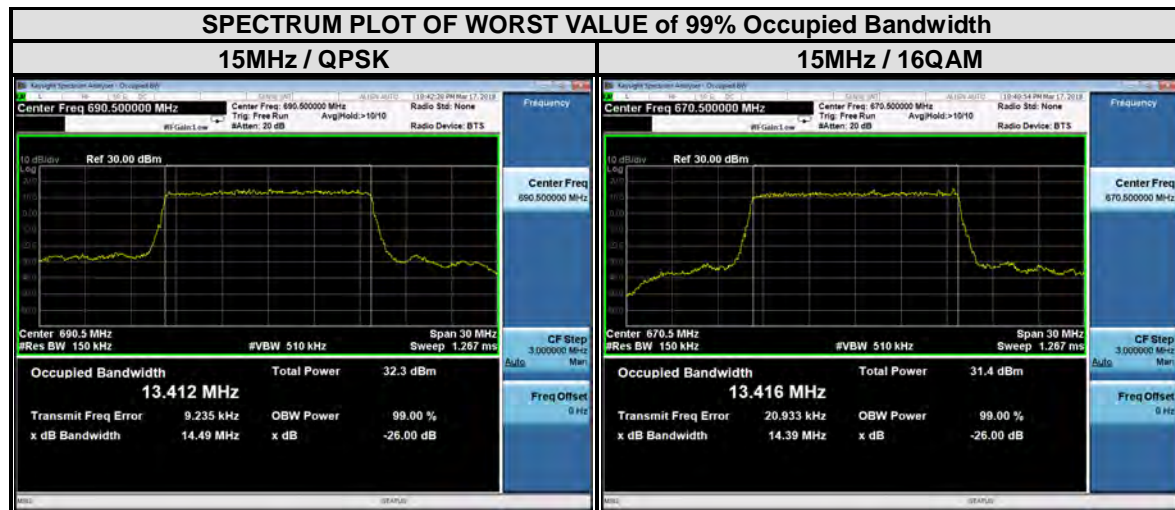



Test Report No.: RF180523W002-7

Channel Bandwidth : 20MHz							
Channel	Frequency (MHz)	99% Occupied bandwidth (MHz)		Channel	Frequency (MHz)	26dB bandwidth (MHz)	
		QPSK	16QAM			QPSK	16QAM
133222	1720	17.81	17.83	133222	1720	18.92	19.27
133297	680.5	17.86	17.85	133297	680.5	19.05	19.17
133372	1770	17.86	17.91	133372	1770	19.17	19.24

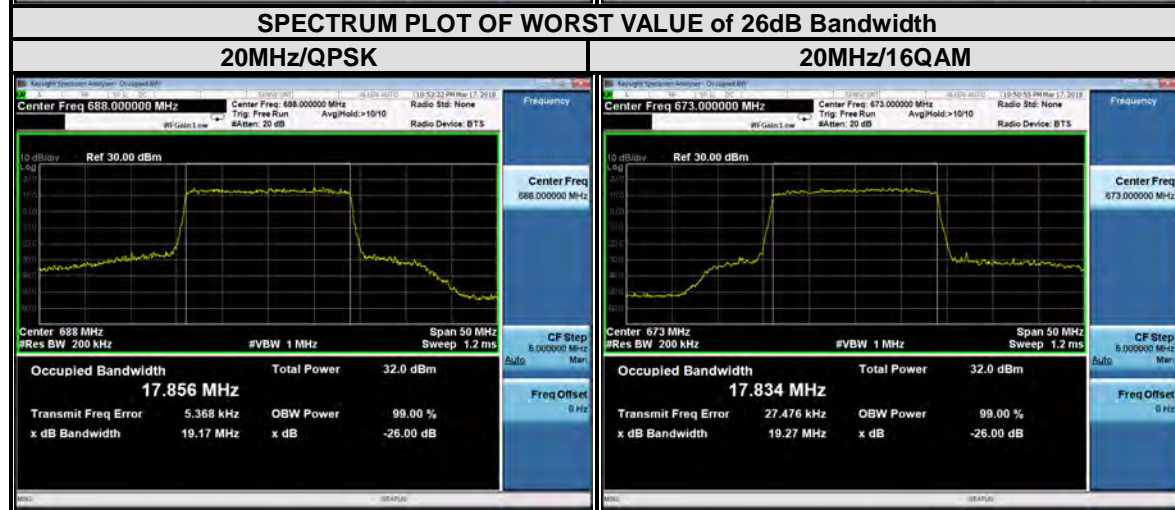
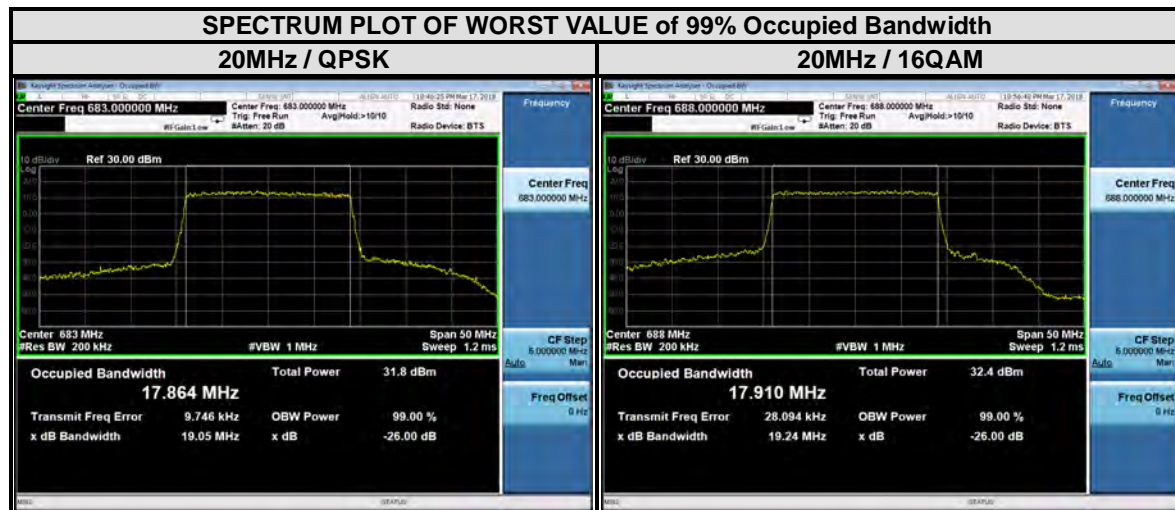

3.4 PEAK TO AVERAGE RATIO

3.4.1 LIMITS OF PEAK TO AVERAGE RATIO MEASUREMENT

In measuring transmissions in this band using an average power technique, the peak to-average ratio (PAR) of the transmission may not exceed 13 dB

3.4.2 TEST SETUP

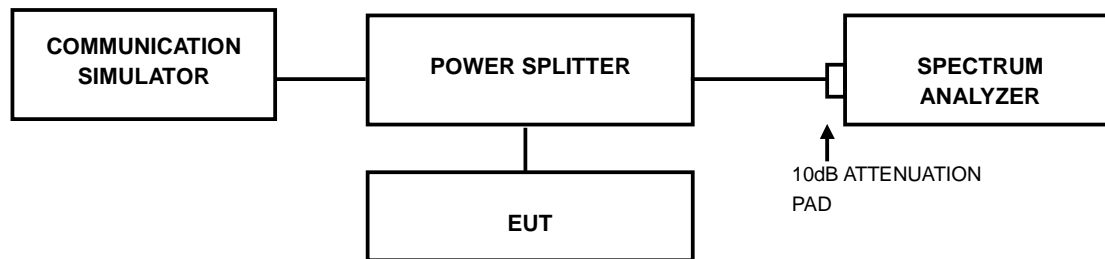

3.4.3 TEST PROCEDURES

1. Set resolution/measurement bandwidth \geq signal's occupied bandwidth;
2. Set the number of counts to a value that stabilizes the measured CCDF curve;
3. Record the maximum PAPR level associated with a probability of 0.1%.



3.4.4 TEST RESULTS

LTE BAND 71

CHANNEL BANDWIDTH: 5MHz				CHANNEL BANDWIDTH: 10MHz			
CHANNEL	FREQUENCY (MHz)	PEAK TO AVERAGE RATIO (dB)		CHANNEL	FREQUENCY (MHz)	PEAK TO AVERAGE RATIO (dB)	
		QPSK	16QAM			QPSK	16QAM
133147	665.5	4.96	5.79	133172	1715	4.91	5.75
133297	680.5	4.86	5.65	133297	680.5	4.66	5.55
133447	695.5	5.08	5.90	133442	1775	4.93	5.81

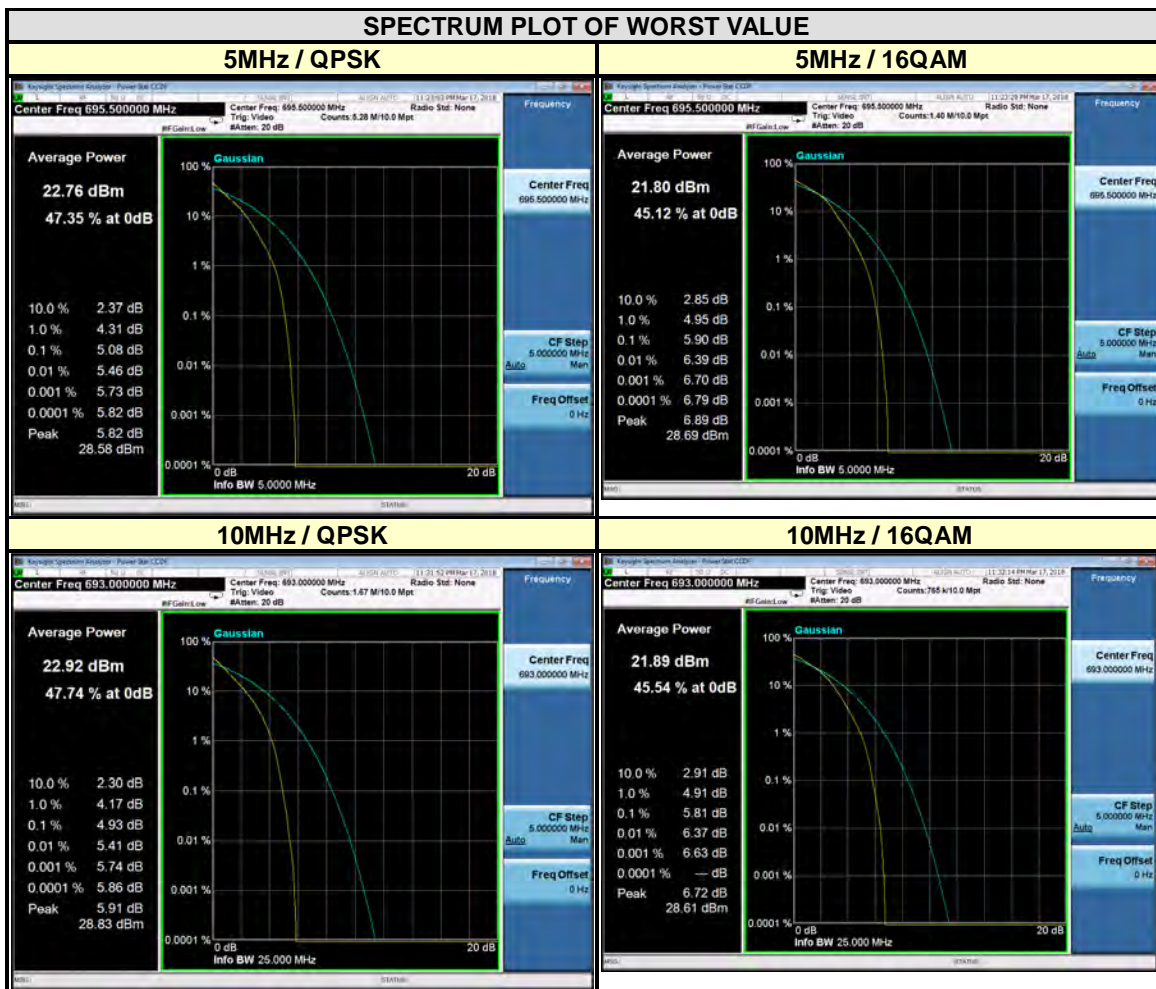



Test Report No.: RF180523W002-7

CHANNEL BANDWIDTH: 15MHz				CHANNEL BANDWIDTH: 20MHz			
CHANNEL	FREQUENCY (MHz)	PEAK TO AVERAGE RATIO (dB)		CHANNEL	FREQUENCY (MHz)	PEAK TO AVERAGE RATIO (dB)	
		QPSK	16QAM			QPSK	16QAM
133197	670.5	5.20	5.92	133222	1720	4.92	5.79
133297	680.5	4.94	5.73	133297	680.5	4.96	5.78
133397	690.5	5.08	5.84	133372	1770	5.12	5.87

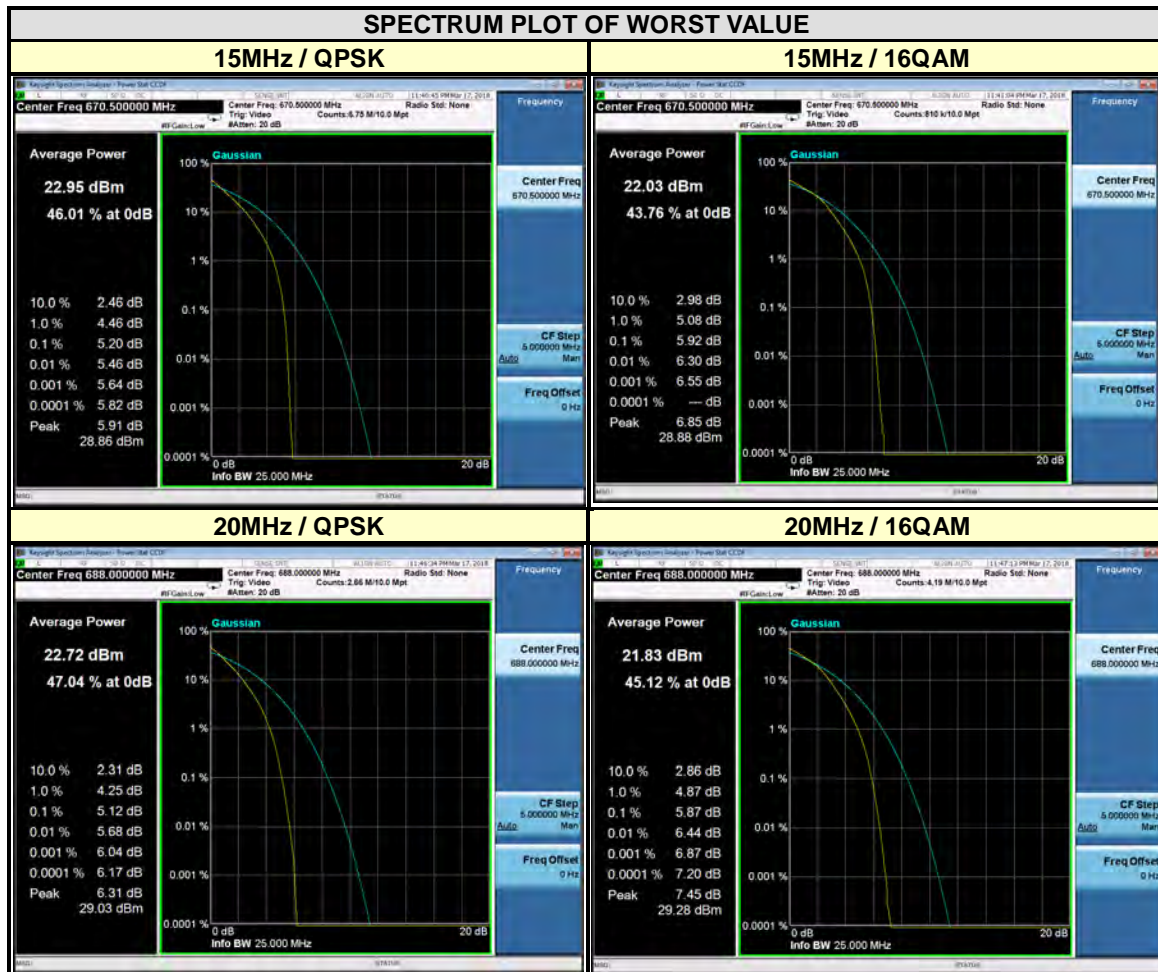

3.5 BAND EDGE MEASUREMENT

3.5.1 LIMITS OF BAND EDGE MEASUREMENT

The power of any emission outside a licensee's frequency band(s) of operation shall be attenuated below the transmitter power (P) within the licensed band(s) of operation, measured in watts, by at least $43 + 10 \log (P)$ dB. Compliance with this provision is based on the use of measurement instrumentation employing a resolution bandwidth of 100 kilohertz or greater.

However, in the 100 kilohertz bands immediately outside and adjacent to a licensee's frequency block, a resolution bandwidth of at least 30 kHz may be employed.

3.5.2 TEST SETUP

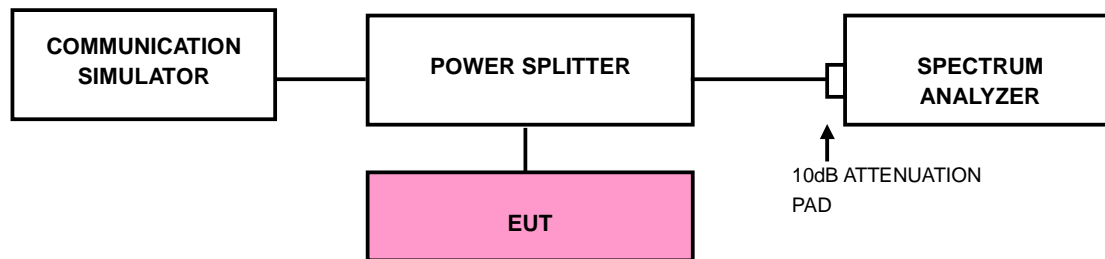



Test Report No.: RF180523W002-7

3.5.3 TEST PROCEDURES

- a. The EUT was set up for the maximum peak power with LTE link data modulation. The power was measured with R&S Spectrum Analyzer. All measurements were done at 2 channels (low and high operational frequency range.).
- b. The band edge measurement used the power splitter via EUT RF power connector between simulation base station and spectrum analyzer.
- c. The center frequency of spectrum is the band edge frequency and span is 1~5 MHz. RBW of the spectrum is 50kHz and VBW of the spectrum is 200kHz. (LTE bandwidth 5MHz)
- d. The center frequency of spectrum is the band edge frequency and span is 1~5 MHz. RBW of the spectrum is 100kHz and VBW of the spectrum is 300kHz. (LTE bandwidth 10MHz)
- e. The center frequency of spectrum is the band edge frequency and span is 1~5 MHz. RBW of the spectrum is 200kHz and VBW of the spectrum is 1MHz. (LTE bandwidth 15MHz)
- f. The center frequency of spectrum is the band edge frequency and span is 1~5 MHz. RBW of the spectrum is 200kHz and VBW of the spectrum is 1MHz. (LTE bandwidth 20MHz)
- g. Record the max trace plot into the test report.



Test Report No.: RF180523W002-7

3.5.4 TEST RESULTS

LTE BAND 71

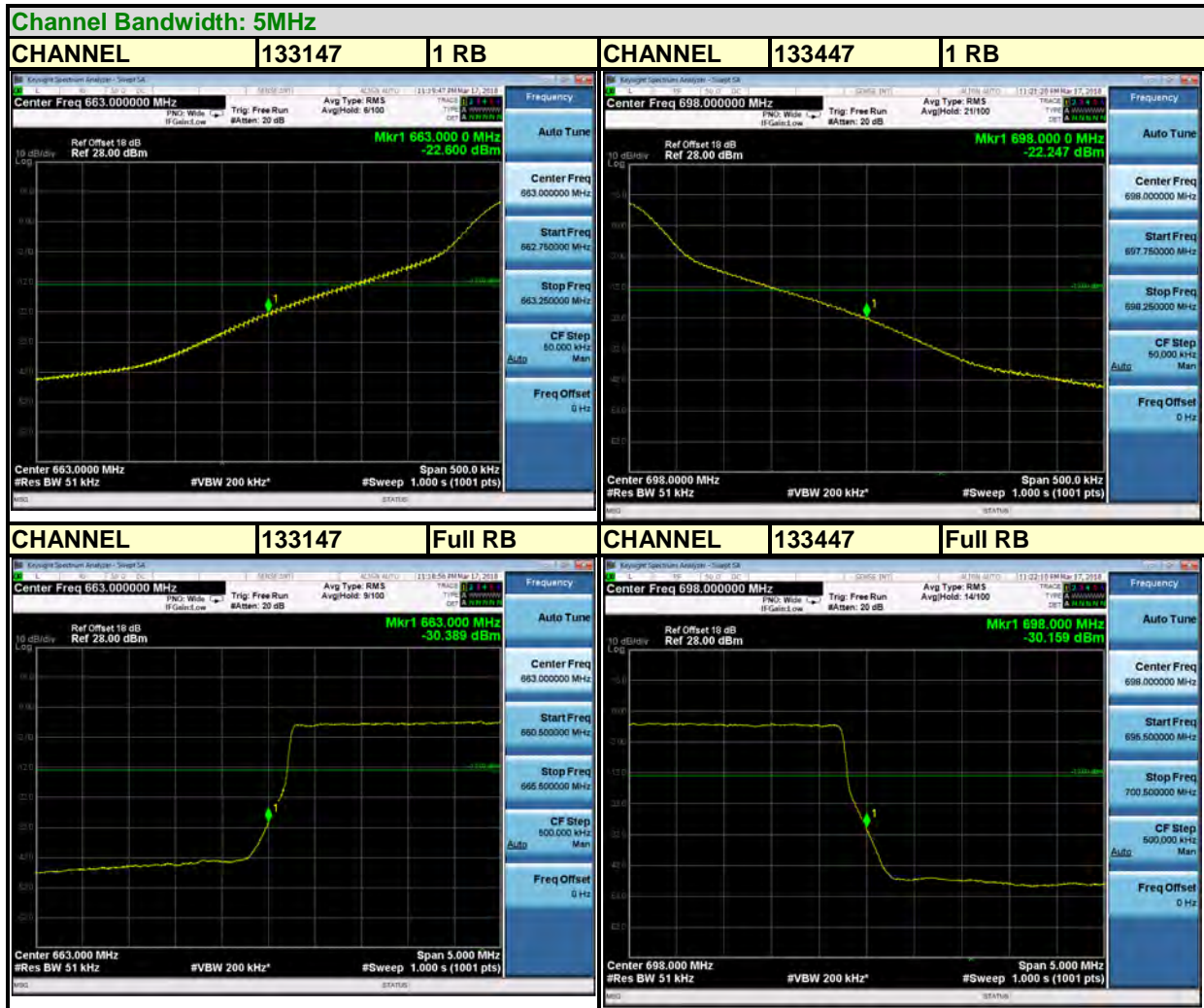



Test Report No.: RF180523W002-7

LTE BAND 71

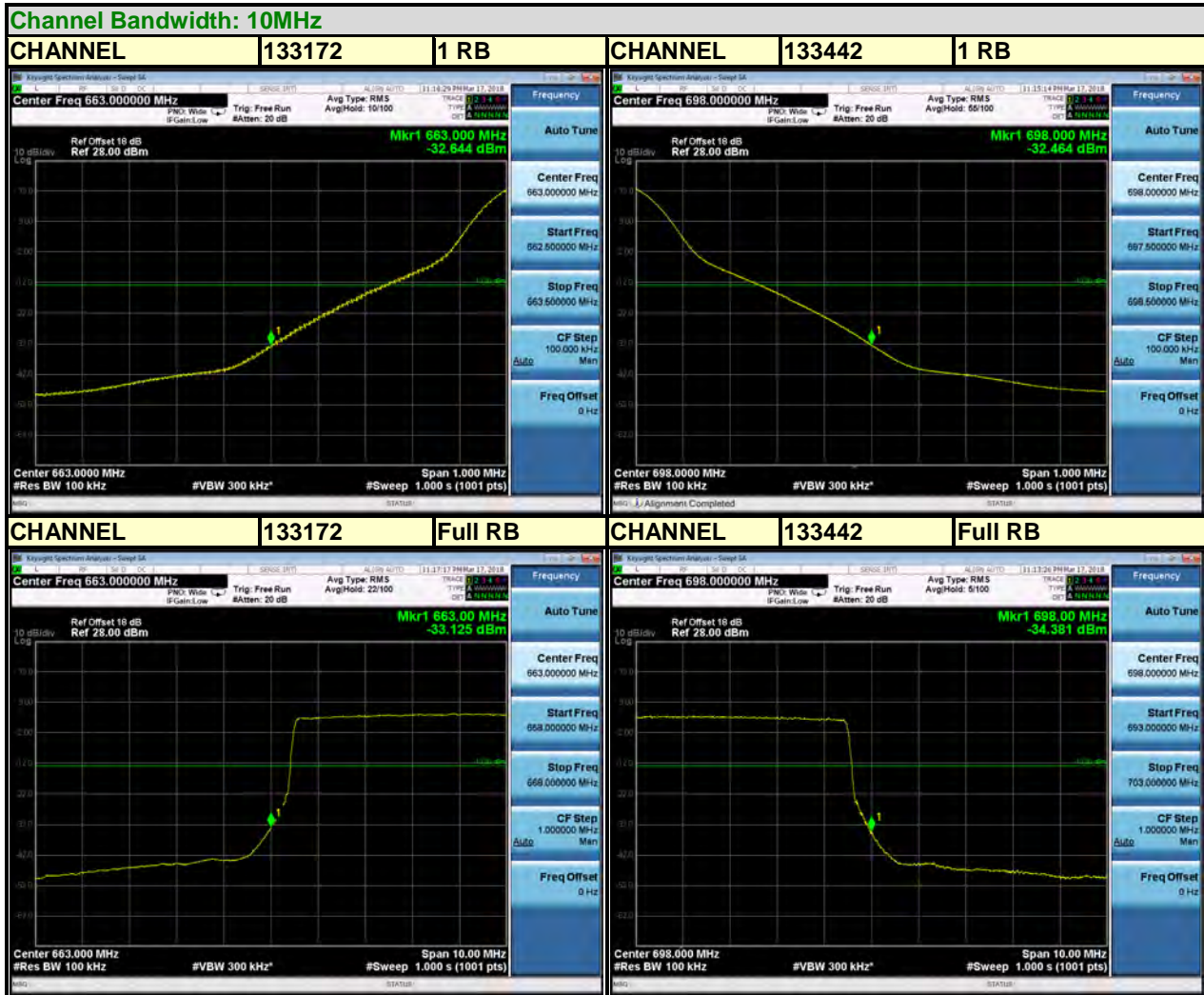



Test Report No.: RF180523W002-7

LTE BAND 71

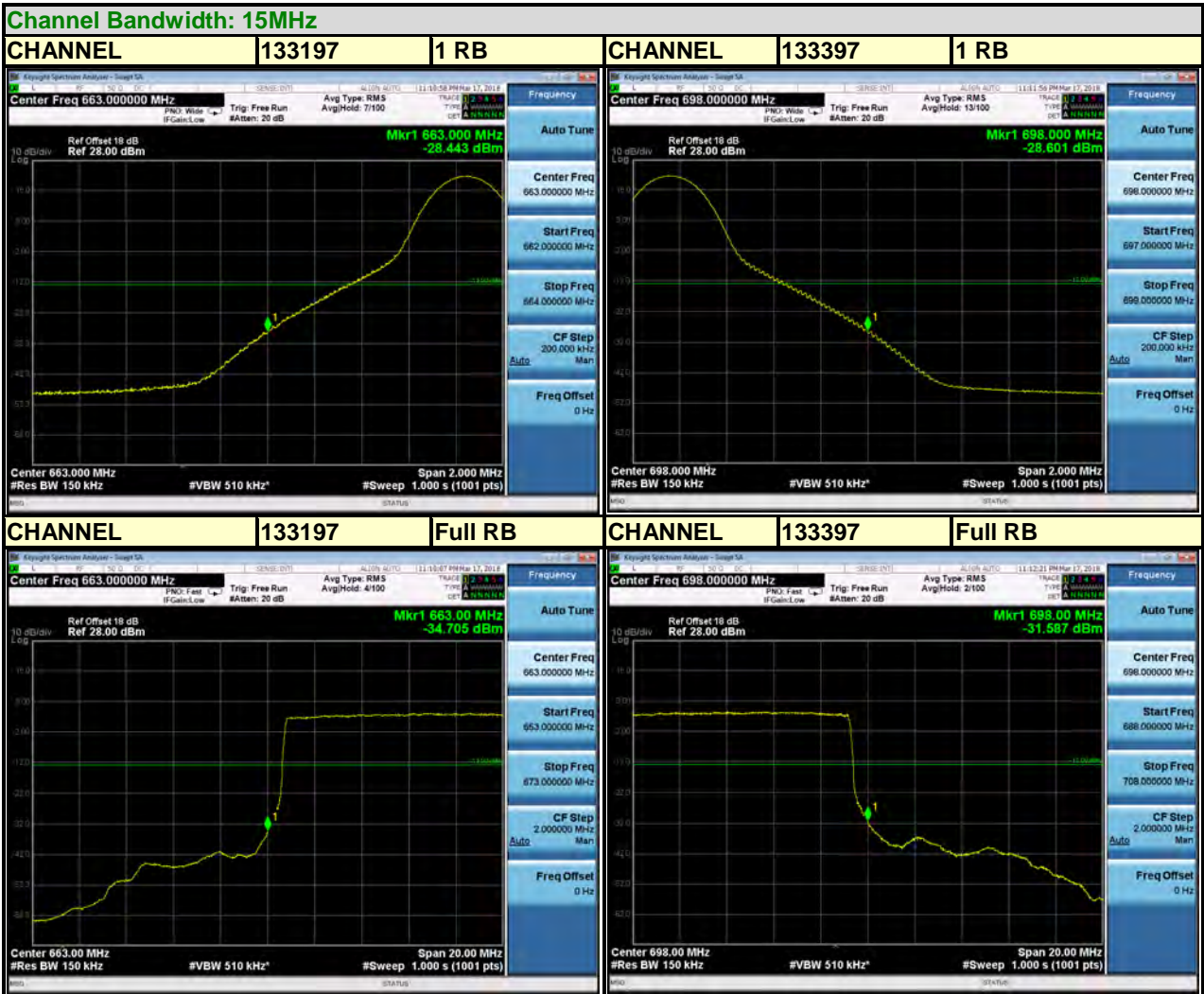



Test Report No.: RF180523W002-7

LTE BAND 71

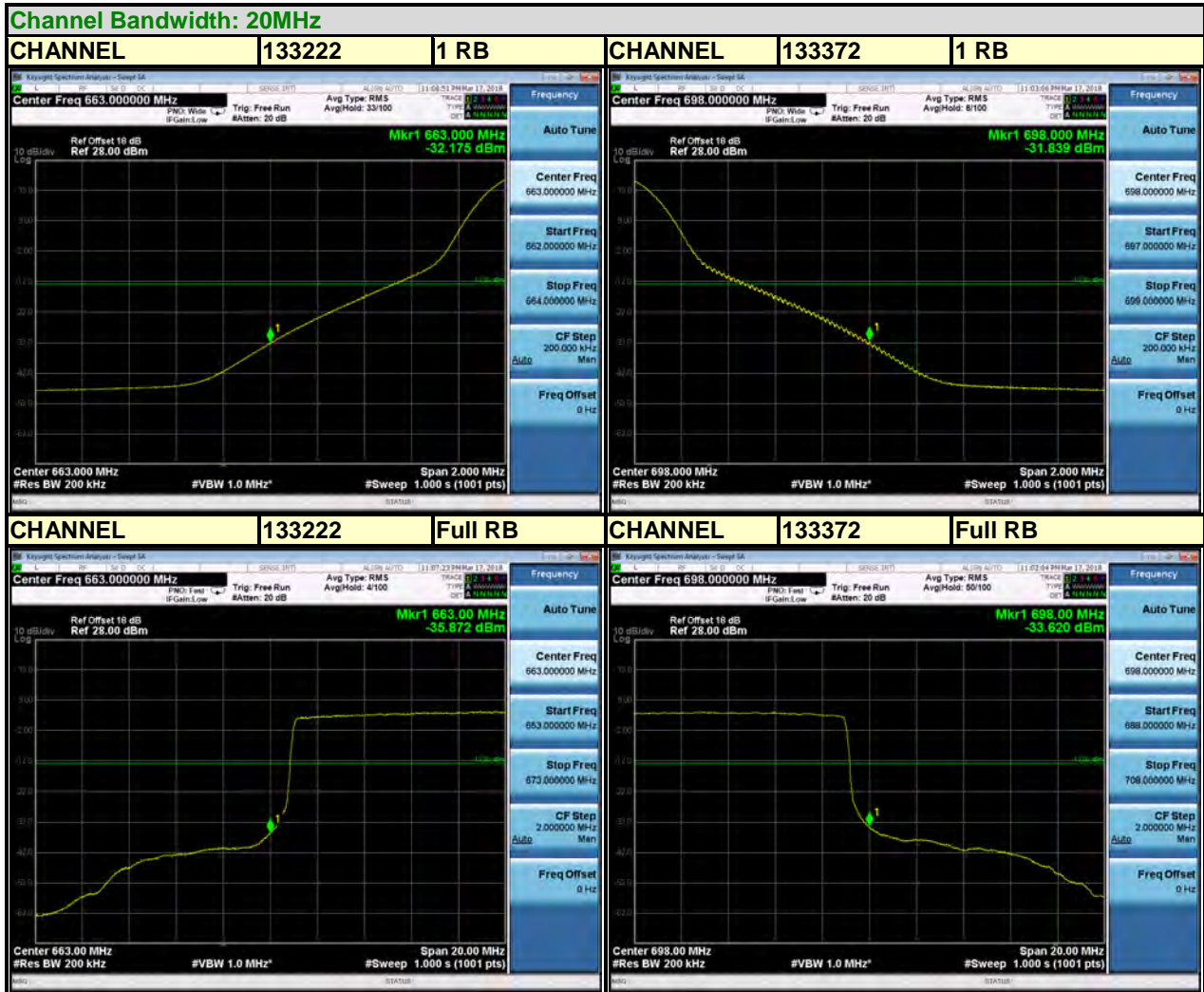

3.6 CONDUCTED SPURIOUS EMISSIONS

3.6.1 LIMITS OF CONDUCTED SPURIOUS EMISSIONS MEASUREMENT

The power of any emission outside a licensee's frequency block shall be attenuated below the transmitter power (P) by at least $43 + 10 \log_{10}(P)$ dB. The limit of emission equal to -13dBm

3.6.2 TEST PROCEDURE

- a. The EUT makes a phone call to the communication simulator. All measurements were done at middle operational frequency range.
- b. Measuring frequency range is from 30 MHz to 6.96GHz for LTE Band 71. 10dB attenuation pad is connected with spectrum. RBW=1MHz and VBW=3MHz are used for conducted emission measurement.

3.6.3 TEST SETUP

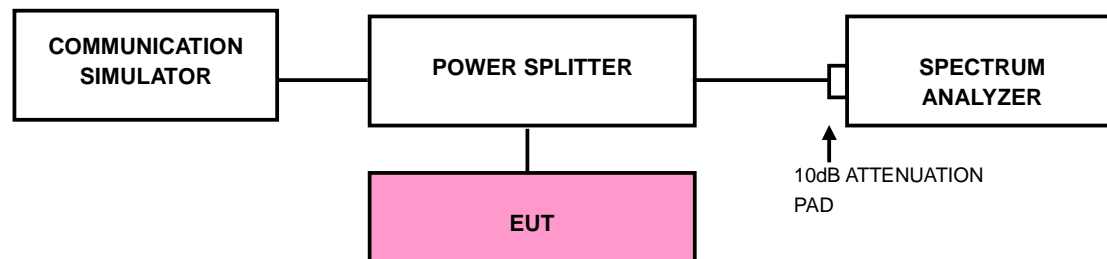



3.6.4 TEST RESULTS

LTE BAND 71

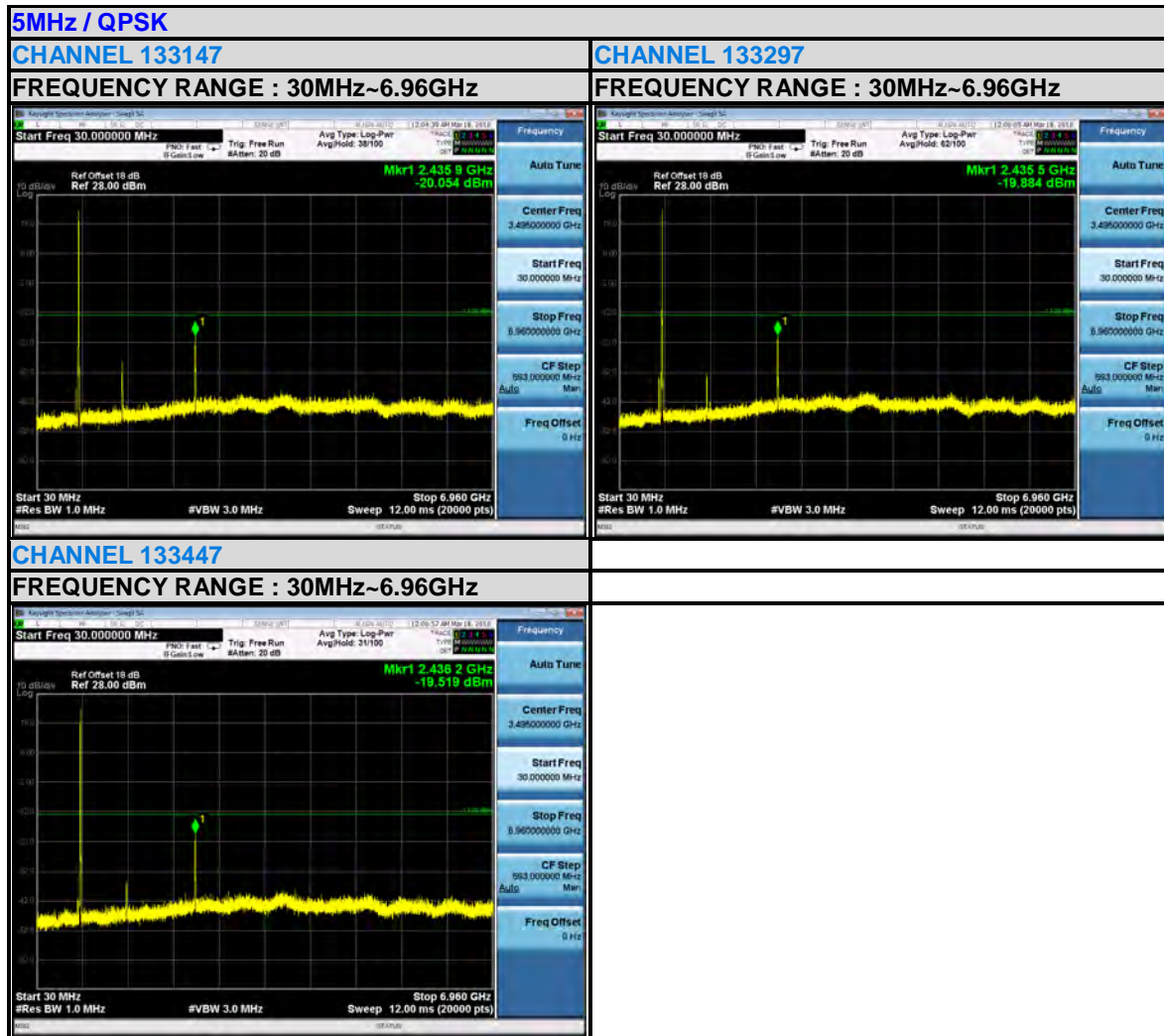



Test Report No.: RF180523W002-7





Test Report No.: RF180523W002-7

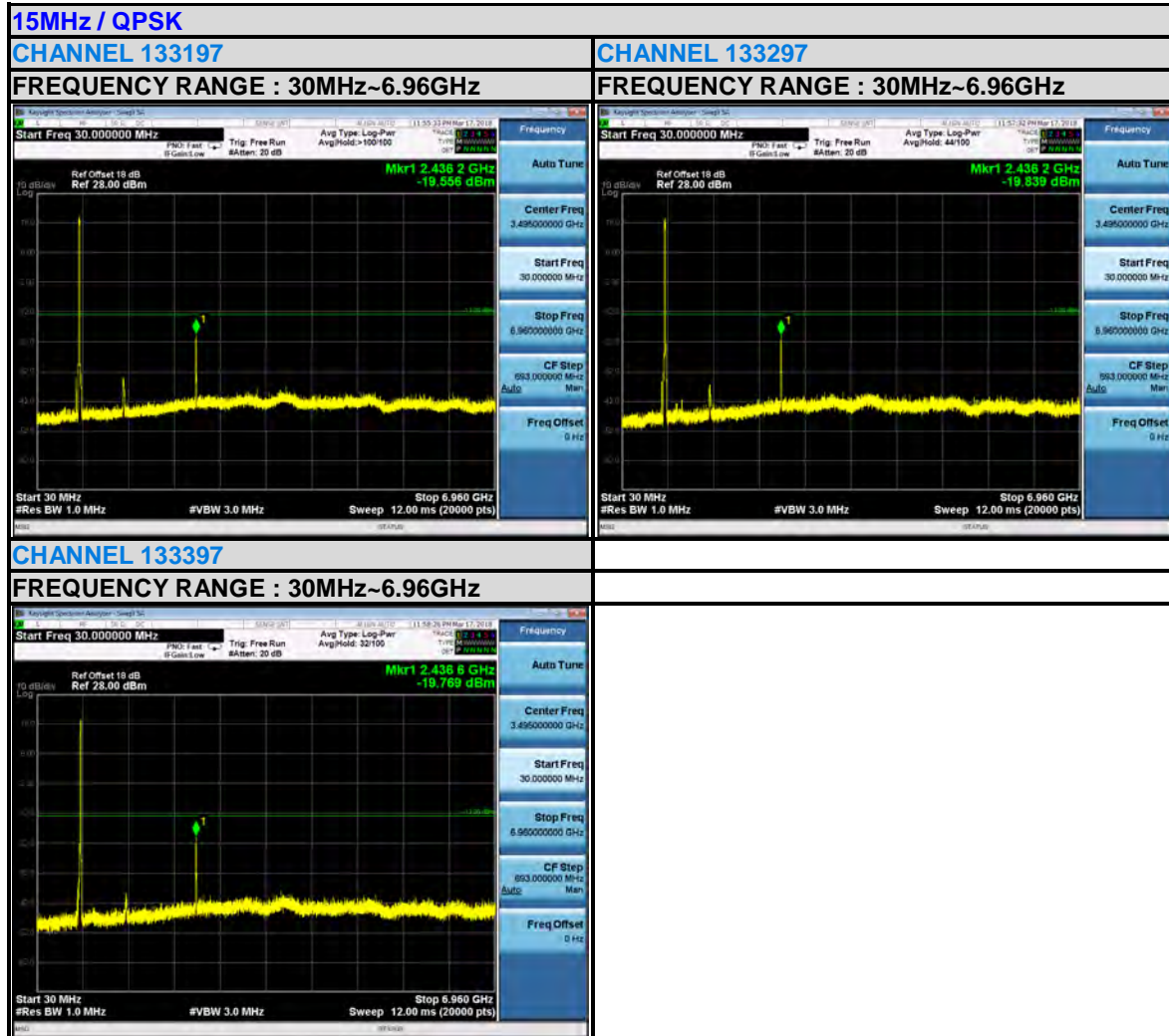



Test Report No.: RF180523W002-7

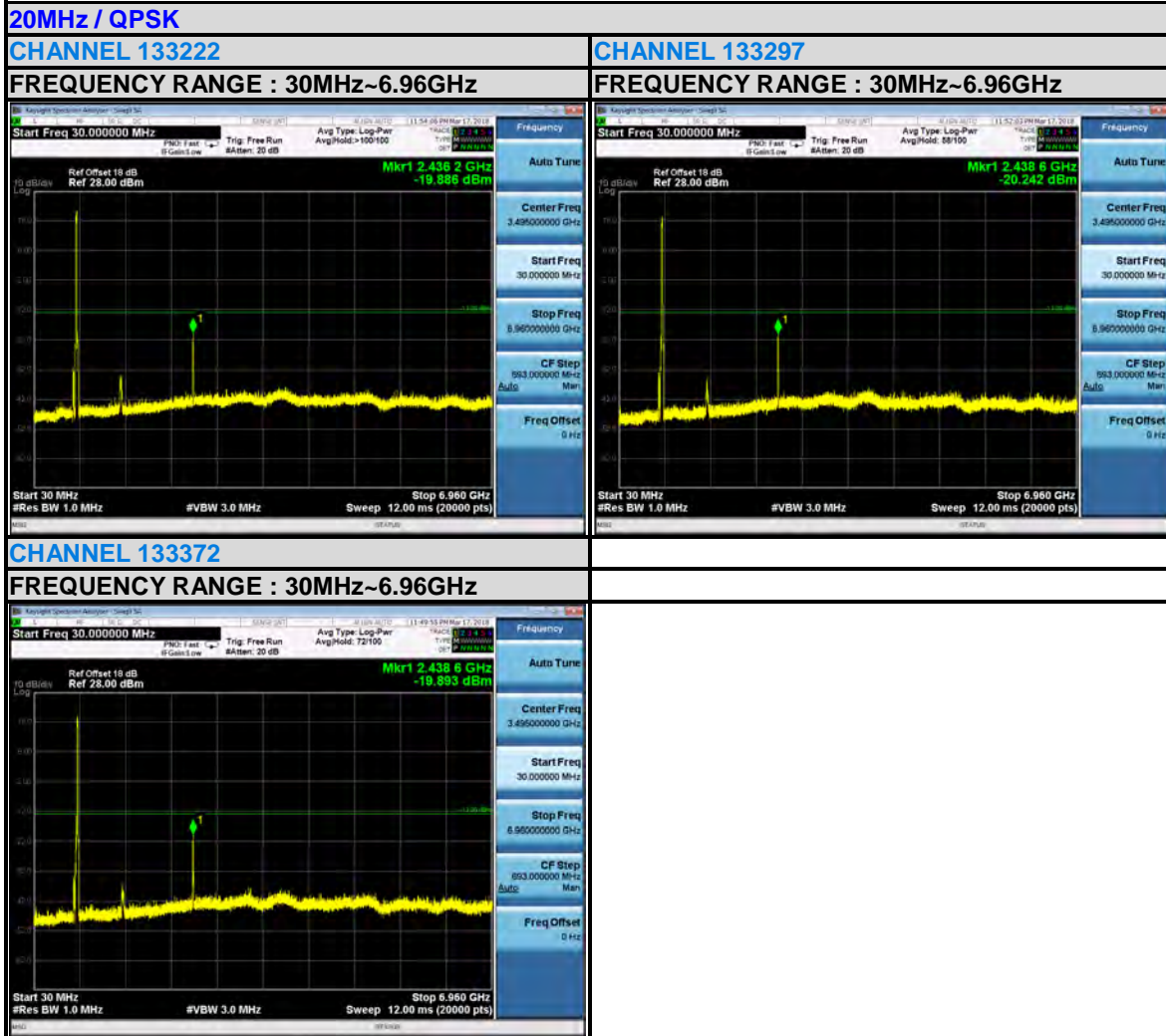



3.7 RADIATED EMISSION MEASUREMENT

3.7.1 LIMITS OF RADIATED EMISSION MEASUREMENT

The power of any emission outside a licensee's frequency block shall be attenuated below the transmitter power (P) by at least $43 + 10 \log_{10}(P)$ dB. The limit of emission equal to -13dBm

3.7.2 TEST PROCEDURES

- a. Substitution method is used for E.I.R.P measurement. In the semi-anechoic chamber, EUT placed on the 0.8m height of Turn Table, rotated the table around 360 degrees to search the maximum radiation power and receiver antenna shall be rotated vertical and horizontal polarization and moved height from 1m to 4m to find the maximum polar radiated power. The "Read Value" is the spectrum reading the maximum power value.
- b. The substitution horn antenna is substituted for EUT at the same position and signals generator export the CW signal to the substitution antenna via a TX cable. Rotated the Turn Table and moved receiving antenna to find the maximum radiation power. Adjust output power level of S.G to get a Value of spectrum reading equal to "Read Value" of step a. Record the power level of S.G
- c. $\text{EIRP} = \text{Output power level of S.G} - \text{TX cable loss} + \text{Antenna gain of substitution horn.}$
- d. E.R.P power can be calculated form E.I.R.P power by subtracting the gain of dipole, $\text{E.R.P power} = \text{E.I.P.R power} - 2.15\text{dBi.}$

NOTE: The resolution bandwidth of spectrum analyzer is 1 MHz and the video bandwidth is 3 MHz.

3.7.3 DEVIATION FROM TEST STANDARD

No deviation

3.7.4 TEST SETUP

<Below 30MHz>

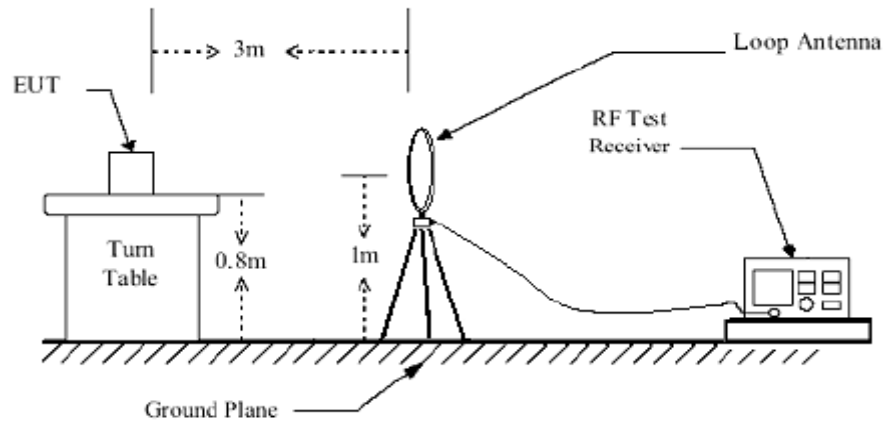

< Frequency Range 30MHz~1GHz >

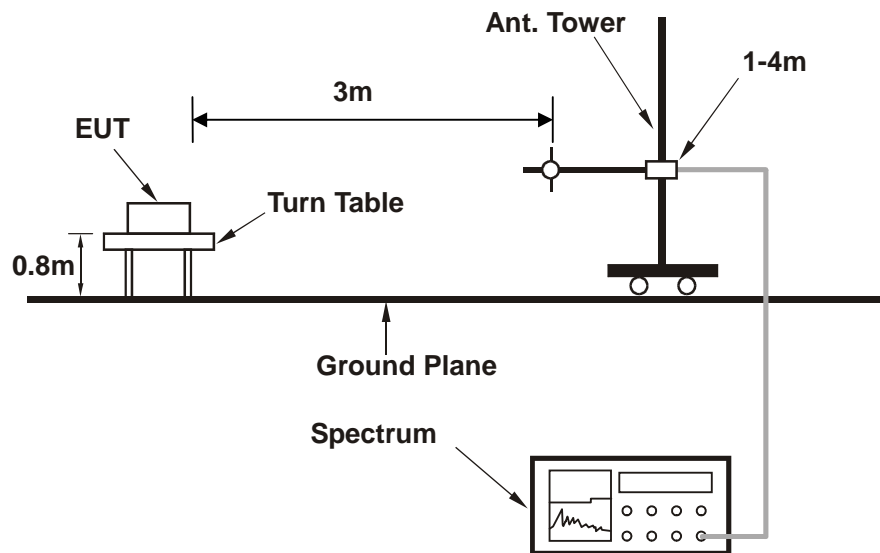

< Frequency Range above 1GHz >

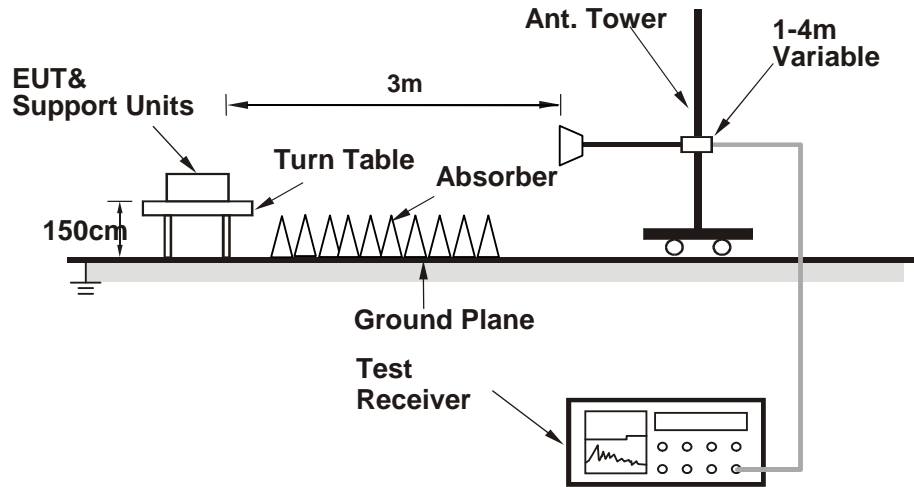

For the actual test configuration, please refer to the attached file (Test Setup Photo).



Test Report No.: RF180523W002-7

3.7.5 TEST RESULTS

LTE BAND 71

CHANNEL BANDWIDTH: 5MHz / QPSK

GH133147

MODE	TX channel 133147	FREQUENCY RANGE	Above 1000MHz
ENVIRONMENTAL CONDITIONS	23deg. C, 70%RH	INPUT POWER	DC 5V from adapter
TESTED BY	Getaz Yang		
ANTENNA POLARITY & TEST DISTANCE: HORIZONTAL AT 3 M			

	Freq	Level	Read Level	Limit Line	Over Limit	Factor	Remark
	MHz	dBm	dBm	dBm	dB	dB	
1	pp	1331.00	-49.12	-37.02	-13.00	-36.12	-12.10 Peak

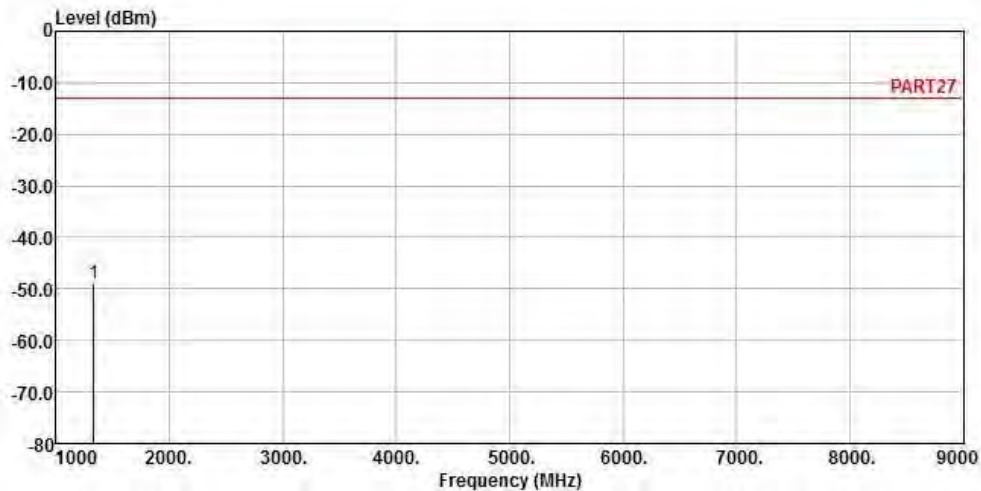



Test Report No.: RF180523W002-7

MODE	TX channel 133147	FREQUENCY RANGE	Above 1000MHz
ENVIRONMENTAL CONDITIONS	23deg. C, 70%RH	INPUT POWER	DC 5V from adapter
TESTED BY	Getaz Yang		
ANTENNA POLARITY & TEST DISTANCE: VERTICAL AT 3 M			

	Freq	Level	Read Level	Limit Line	Over Limit	Factor	Remark
	MHz	dBm	dBm	dBm	dB	dB	
1	pp	1331.00	-46.41	-34.31	-13.00	-33.41	-12.10 Peak

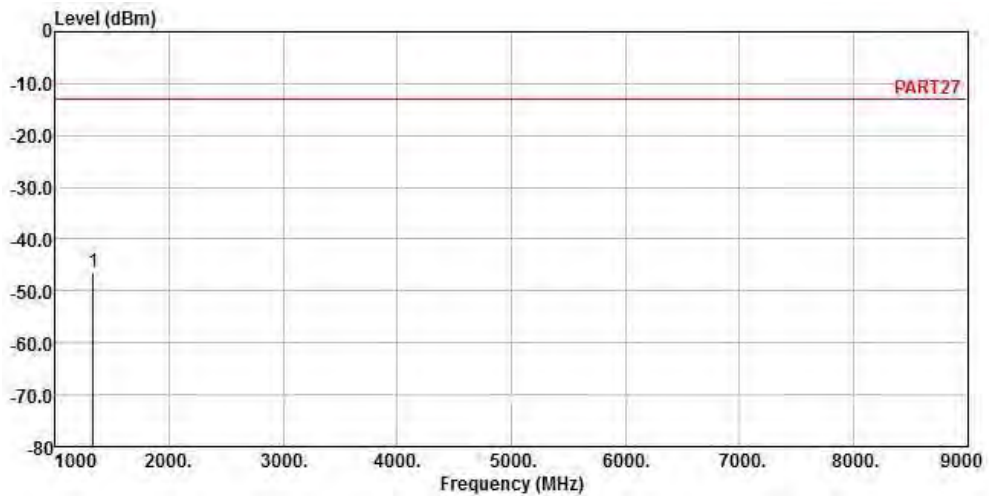



Test Report No.: RF180523W002-7

GH133297

MODE	TX channel 133297	FREQUENCY RANGE	Above 1000MHz
ENVIRONMENTAL CONDITIONS	23deg. C, 70%RH	INPUT POWER	DC 5V from adapter
TESTED BY	Getaz Yang		
ANTENNA POLARITY & TEST DISTANCE: HORIZONTAL AT 3 M			

Freq	Level	Read Level	Limit Line	Over Limit	Factor	Remark
MHz	dBm	dBm	dBm	dB	dB	
1 pp 1361.00	-47.63	-35.65	-13.00	-34.63	-11.98	Peak

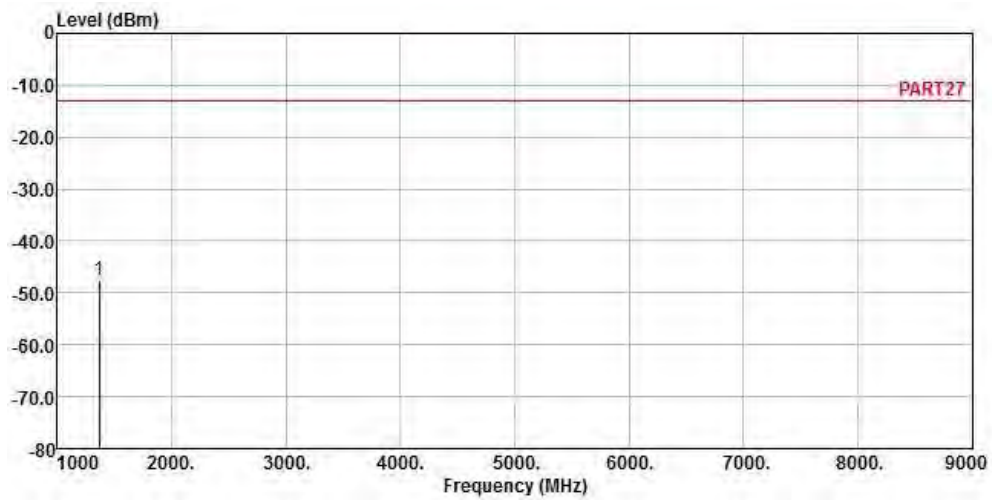



Test Report No.: RF180523W002-7

MODE	TX channel 133297	FREQUENCY RANGE	Above 1000MHz
ENVIRONMENTAL CONDITIONS	23deg. C, 70%RH	INPUT POWER	DC 5V from adapter
TESTED BY	Getaz Yang		
ANTENNA POLARITY & TEST DISTANCE: VERTICAL AT 3 M			

	Read	Limit	Over			
Freq	Level	Level	Line	Limit	Factor	Remark
MHz	dBm	dBm	dBm	dB	dB	
1 pp 1361.00	-45.63	-33.65	-13.00	-32.63	-11.98	Peak

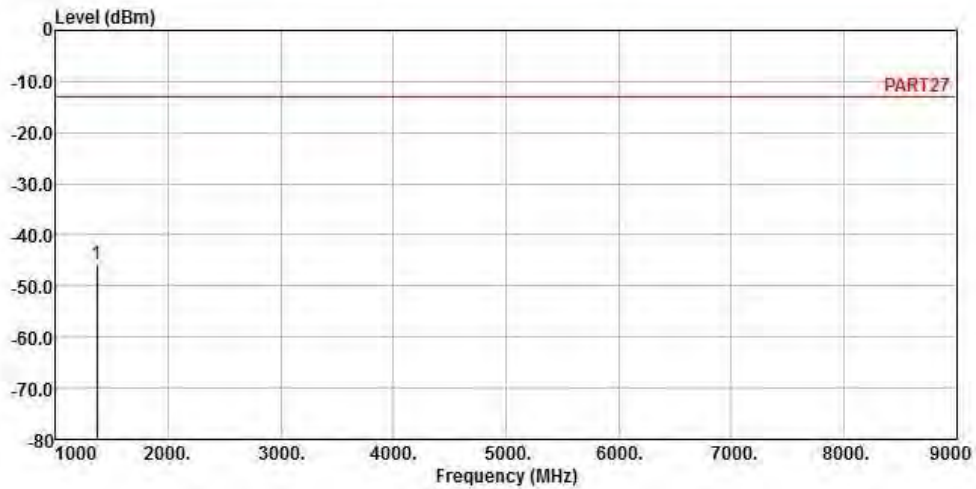



Test Report No.: RF180523W002-7

GH133447

MODE	TX channel 133447	FREQUENCY RANGE	Above 1000MHz
ENVIRONMENTAL CONDITIONS	23deg. C, 70%RH	INPUT POWER	DC 5V from adapter
TESTED BY	Getaz Yang		
ANTENNA POLARITY & TEST DISTANCE: HORIZONTAL AT 3 M			

Freq	Level	Read Level	Limit Line	Over Limit	Factor	Remark
MHz	dBm	dBm	dBm	dB	dB	
1 pp 1391.00	-49.19	-37.31	-13.00	-36.19	-11.88	Peak

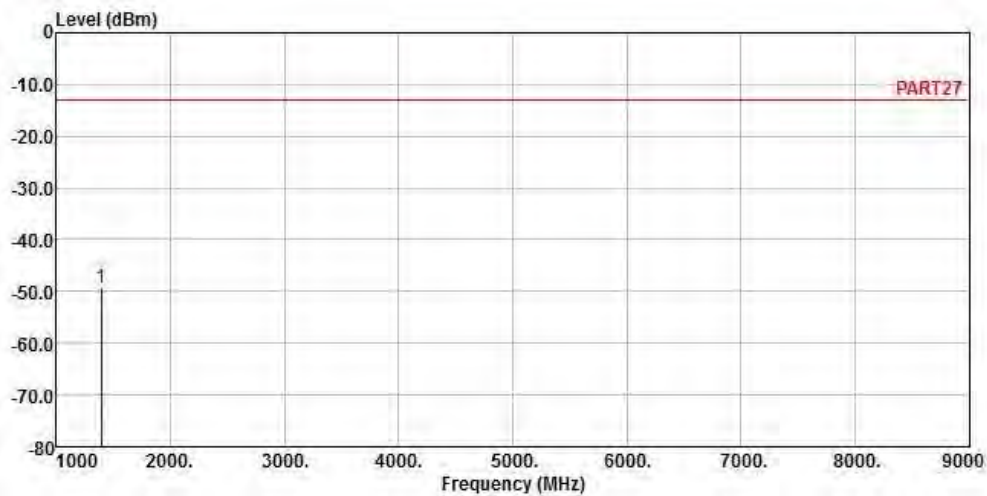



Test Report No.: RF180523W002-7

MODE	TX channel 133447	FREQUENCY RANGE	Above 1000MHz
ENVIRONMENTAL CONDITIONS	23deg. C, 70%RH	INPUT POWER	DC 5V from adapter
TESTED BY	Getaz Yang		
ANTENNA POLARITY & TEST DISTANCE: VERTICAL AT 3 M			

Read	Limit	Over				
Freq	Level	Level	Line	Limit	Factor	Remark
MHz	dBm	dBm	dBm	dB	dB	
1 pp 1391.00	-45.07	-33.19	-13.00	-32.07	-11.88	Peak

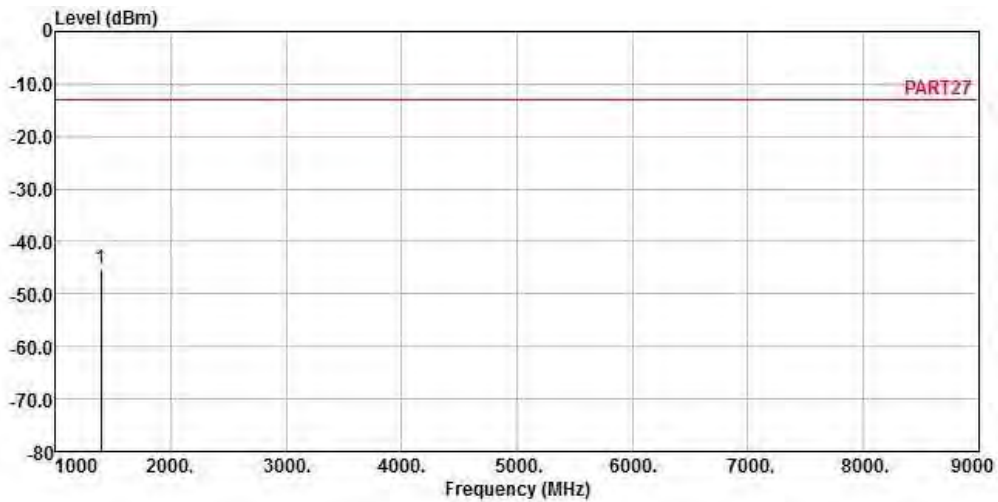



Test Report No.: RF180523W002-7

CHANNEL BANDWIDTH: 20MHz / QPSK

CH133222

MODE	TX channel 133222	FREQUENCY RANGE	Above 1000MHz
ENVIRONMENTAL CONDITIONS	23deg. C, 70%RH	INPUT POWER	DC 5V from adapter
TESTED BY	Getaz Yang		
ANTENNA POLARITY & TEST DISTANCE: HORIZONTAL AT 3 M			

Freq	Level	Read Level	Limit Line	Over Limit	Factor	Remark
MHz	dBm	dBm	dBm	dB	dB	
1 pp 1346.00	-46.93	-34.89	-13.00	-33.93	-12.04	Peak

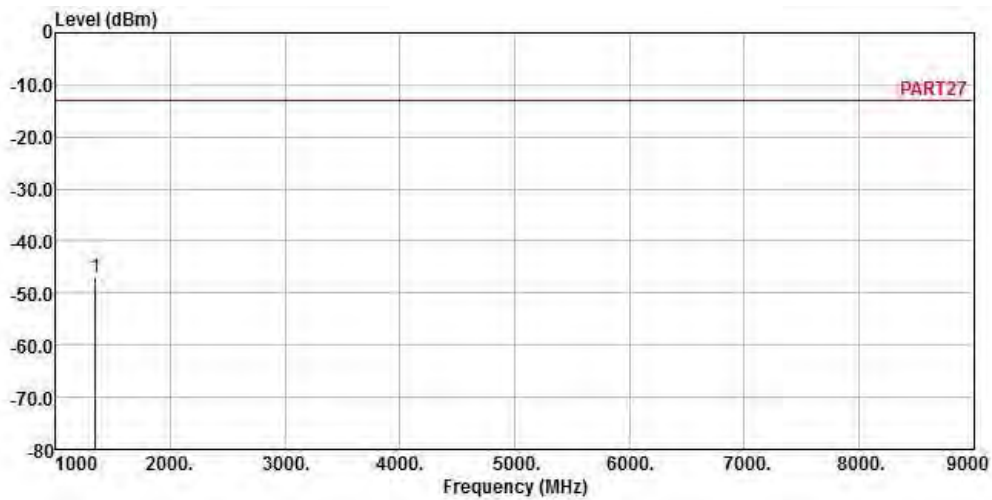



Test Report No.: RF180523W002-7

MODE	TX channel 133222	FREQUENCY RANGE	Above 1000MHz
ENVIRONMENTAL CONDITIONS	23deg. C, 70%RH	INPUT POWER	DC 5V from adapter
TESTED BY	Getaz Yang		
ANTENNA POLARITY & TEST DISTANCE: VERTICAL AT 3 M			

1	Freq	Level	Read Level	Limit Line	Over Limit	Factor	Remark
	MHz	dBm	dBm	dBm	dB	dB	
1	pp 1346.00	-44.45	-32.41	-13.00	-31.45	-12.04	Peak

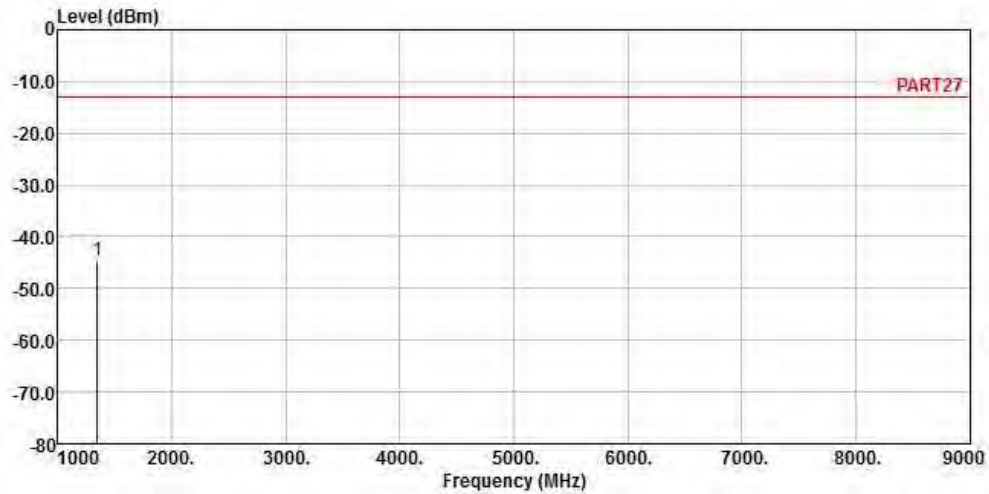



Test Report No.: RF180523W002-7

CH133297

MODE	TX channel 133297	FREQUENCY RANGE	Above 1000MHz
ENVIRONMENTAL CONDITIONS	23deg. C, 70%RH	INPUT POWER	DC 5V from adapter
TESTED BY	Getaz Yang		
ANTENNA POLARITY & TEST DISTANCE: HORIZONTAL AT 3 M			

	Freq	Level	Read Level	Limit Line	Over Limit	Factor	Remark
	MHz	dBm	dBm	dBm	dB	dB	
1	pp	30.00	-44.52	-44.90	-13.00	-31.52	0.38 Peak
2		43.50	-54.14	-52.67	-13.00	-41.14	-1.47 Peak
3		91.29	-53.29	-42.24	-13.00	-40.29	-11.05 Peak
4		168.24	-62.73	-57.27	-13.00	-49.73	-5.46 Peak
5		281.10	-63.08	-56.45	-13.00	-50.08	-6.63 Peak
6		741.00	-59.48	-60.19	-13.00	-46.48	0.71 Peak
7		1361.00	-45.89	-33.91	-13.00	-32.89	-11.98 Peak

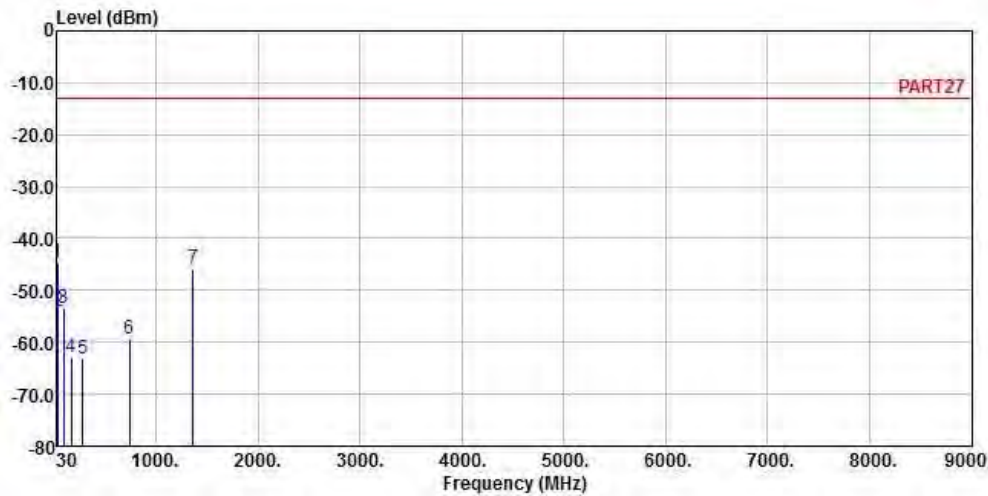



Test Report No.: RF180523W002-7

MODE	TX channel 133297	FREQUENCY RANGE	Above 1000MHz
ENVIRONMENTAL CONDITIONS	23deg. C, 70%RH	INPUT POWER	DC 5V from adapter
TESTED BY	Getaz Yang		
ANTENNA POLARITY & TEST DISTANCE: VERTICAL AT 3 M			

	Freq	Level	Read Level	Limit Line	Over Limit	Factor	Remark
	MHz	dBm	dBm	dBm	dB	dB	
1 pp	32.43	-36.75	-35.66	-13.00	-23.75	-1.09	Peak
2	43.50	-43.47	-42.00	-13.00	-30.47	-1.47	Peak
3	84.81	-55.37	-44.37	-13.00	-42.37	-11.00	Peak
4	169.86	-68.21	-62.68	-13.00	-55.21	-5.53	Peak
5	473.60	-68.33	-63.21	-13.00	-55.33	-5.12	Peak
6	754.30	-63.06	-63.93	-13.00	-50.06	0.87	Peak
7	1361.00	-42.51	-30.53	-13.00	-29.51	-11.98	Peak

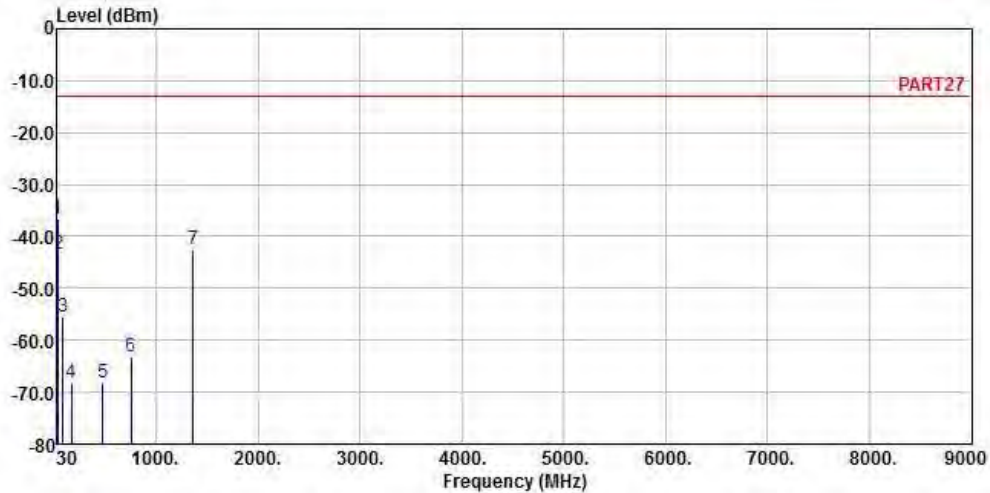



Test Report No.: RF180523W002-7

CH133372

MODE	TX channel 133372	FREQUENCY RANGE	Above 1000MHz
ENVIRONMENTAL CONDITIONS	23deg. C, 70%RH	INPUT POWER	DC 5V from adapter
TESTED BY	Getaz Yang		
ANTENNA POLARITY & TEST DISTANCE: HORIZONTAL AT 3 M			

	Read	Limit	Over			
Freq	Level	Level	Line	Limit	Factor	Remark
MHz	dBm	dBm	dBm	dB	dB	
1 pp	1376.00	-49.18	-37.26	-13.00	-36.18	-11.92 Peak

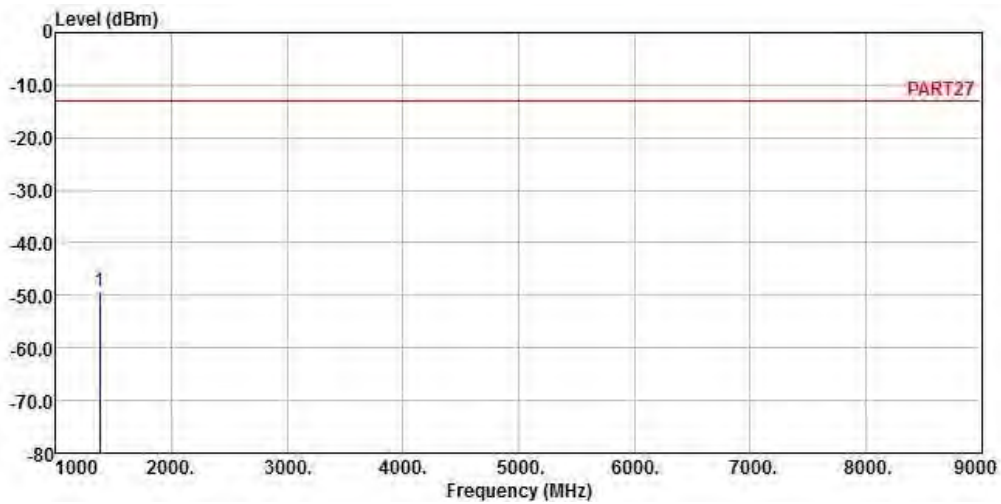



Test Report No.: RF180523W002-7

MODE	TX channel 133372	FREQUENCY RANGE	Above 1000MHz
ENVIRONMENTAL CONDITIONS	23deg. C, 70%RH	INPUT POWER	DC 5V from adapter
TESTED BY	Getaz Yang		
ANTENNA POLARITY & TEST DISTANCE: VERTICAL AT 3 M			

	Read	Limit	Over		
Freq	Level	Level	Line	Limit	Factor
MHz	dBm	dBm	dBm	dB	dB
1 pp 1376.00	-47.53	-35.61	-13.00	-34.53	-11.92 Peak

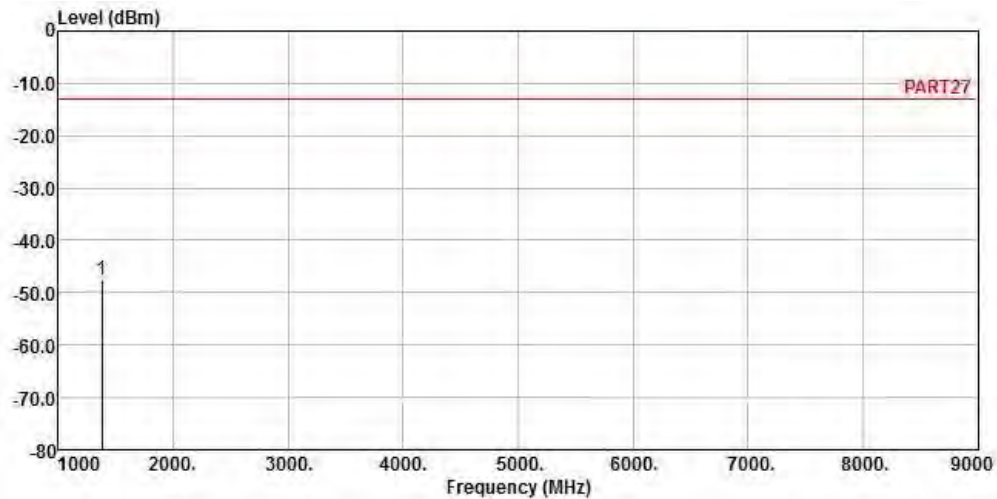

Note: Radiated Spurious Emissions Test was performed by **Bureau Veritas Consumer Products Services (H.K.) Ltd., Taoyuan Branch**



Test Report No.: RF180523W002-7

4 INFORMATION ON THE TESTING LABORATORIES

We, BV 7LAYERS COMMUNICATIONS TECHNOLOGY (SHENZHEN) CO. LTD., were founded in 2015 to provide our best service in EMC, Radio, Telecom and Safety consultation. Our laboratories are accredited and approved according to ISO/IEC 17025.

If you have any comments, please feel free to contact us at the following:

Shenzhen EMC/RF Lab:

Tel: +86-755-88696566

Fax: +86-755-88696577

Email: customerservice.dg@cn.bureauveritas.com

Web Site: www.adt.com.tw

The address and road map of all our labs can be found in our web site also.



Test Report No.: RF180523W002-7

5 APPENDIX A – MODIFICATIONS RECORDERS FOR ENGINEERING CHANGES TO THE EUT BY THE LAB

No modifications were made to the EUT by the lab during the test.

---END---