

FCC TEST REPORT

Client Name : EPSILON ELECTRONICS,INC
Address : 1550 South Maple Ave. Montebello, CA 90640, U.S.A
Product Name : Sound Table
Date : Apr. 01, 2019

Shenzhen Anbotek Compliance Laboratory Limited

Contents

1. General Information.....	5
1.1. Client Information.....	5
1.2. Description of Device (EUT).....	5
1.3. Auxiliary Equipment Used During Test.....	6
1.4. Description of Test Modes.....	6
1.5. List of channels.....	7
1.7. Test Equipment List.....	9
1.8. Measurement Uncertainty.....	10
1.9. Description of Test Facility.....	10
2. Summary of Test Results.....	11
3. Conducted Emission Test.....	12
3.1. Test Standard and Limit.....	12
3.2. Test Setup.....	12
3.3. Test Procedure.....	12
3.4. Test Data.....	13
4. Radiation Spurious Emission and Band Edge.....	22
4.1. Test Standard and Limit.....	22
4.2. Test Setup.....	22
4.3. Test Procedure.....	23
4.4. Test Data.....	24
5. Maximum Peak Output Power Test.....	38
5.1. Test Standard and Limit.....	38
5.2. Test Setup.....	38
5.3. Test Procedure.....	38
5.4. Test Data.....	38
6. 6DB Occupy Bandwidth Test.....	41
6.1. Test Standard and Limit.....	41
6.2. Test Setup.....	41
6.3. Test Procedure.....	41
6.4. Test Data.....	41
7. Power Spectral Density Test.....	44
7.1. Test Standard and Limit.....	44
7.2. Test Setup.....	44
7.3. Test Procedure.....	44
7.4. Test Data.....	44
8. 100kHz Bandwidth of Frequency Band Edge Requirement.....	47
8.1. Test Standard and Limit.....	47

8.2. Test Setup.....	47
8.3. Test Procedure.....	47
8.4. Test Data.....	47
9. Antenna Requirement.....	51
9.1. Test Standard and Requirement.....	51
9.2. Antenna Connected Construction.....	51
APPENDIX I -- TEST SETUP PHOTOGRAPH.....	52
APPENDIX II -- EXTERNAL PHOTOGRAPH.....	53
APPENDIX III -- INTERNAL PHOTOGRAPH.....	54

TEST REPORT

Applicant : EPSILON ELECTRONICS,INC
Manufacturer : DONGGUAN CITY BLUEMAN ELECTRONIC TECHNOLOGY CO., LTD.
Product Name : Sound Table
 ST-180MCM-G, ST-180MCM-B, ST-360MCM-G, ST-180TRD-G,
Model No. : ST-180TRD-B, ST-180AMA-G, ST-180AMA-B, ST-180ARTD-G,
 ST-180ARTD-B, ST-180RET-G, ST-180RET-B, ST-180MOD-G,
 ST-180MOD-B
Trade Mark : SOUNDSTREAM
 Input: DC 18V, 3.5A(via adapter input:AC 100~240V,50/60Hz ,1.5A)
Rating(s) : Wireless Output: 5W
 USB output: DC 5V, 2.4A

Test Standard(s) : FCC Part15 Subpart C 2018, Section 15.247

Test Method(s) : ANSI C63.10: 2013, KDB558074 D01 DTS Meas Guidance v05

The device described above is tested by Shenzhen Anbotek Compliance Laboratory Limited to determine the maximum emission levels emanating from the device and the severe levels of the device can endure and its performance criterion. The measurement results are contained in this test report and Shenzhen Anbotek Compliance Laboratory Limited is assumed full of responsibility for the accuracy and completeness of these measurements. Also, this report shows that the EUT (Equipment Under Test) is technically compliant with the FCC Part 15 Subpart C requirements.

This report applies to above tested sample only and shall not be reproduced in part without written approval of Shenzhen Anbotek Compliance Laboratory Limited.

Date of Receipt

Feb. 12, 2019

Date of Test

Feb. 12~Apr. 01, 2019

Prepared By



Oliay Yang

(Engineer / Oliay Yang)

Reviewer

Snowy Meng

(Supervisor / Snowy Meng)

Approved & Authorized Signer

Sally Zhang

(Manager / Sally Zhang)



1. General Information

1.1. Client Information

Applicant	:	EPSILON ELECTRONICS,INC
Address	:	1550 South Maple Ave. Montebello, CA 90640, U.S.A
Manufacturer	:	DONGGUAN CITY BLUEMAN ELECTRONIC TECHNOLOGY CO., LTD.
Address	:	Building B, No.5, Shunxing Five Road, Dajingtou Community, Dalang Town, Dongguan City, Guangdong Province
Factory	:	DONGGUAN CITY BLUEMAN ELECTRONIC TECHNOLOGY CO., LTD.
Address	:	Building B, No.5, Shunxing Five Road, Dajingtou Community, Dalang Town, Dongguan City, Guangdong Province

1.2. Description of Device (EUT)

Product Name	:	Sound Table
Model No.	:	ST-180MCM-G, ST-180MCM-B, ST-360MCM-G, ST-180TRD-G, ST-180TRD-B, ST-180AMA-G, ST-180AMA-B, ST-180ARTD-G, ST-180ARTD-B, ST-180RET-G, ST-180RET-B, ST-180MOD-G, ST-180MOD-B (Note: All samples are the same except the color, material and appearance, so we prepare "ST-180MCM-G " for test only.)
Trade Mark	:	SOUNDSTREAM
Test Power Supply	:	AC 120V, 60Hz for adapter / AC 240V, 60Hz for adapter
Test Sample No.	:	S1(Normal Sample), S2(Engineering Sample)
Product Description	Operation Frequency:	2402MHz~2480MHz
	Transfer Rate:	1 Mbits/s
	Number of Channel:	40 Channels
	Modulation Type:	GFSK
	Antenna Type:	PCB Antenna
	Antenna Gain(Peak):	0.5 dBi
<p>Remark: 1) For a more detailed features description, please refer to the manufacturer's specifications or the User's Manual. 2)This report is for BT 4.2 BLE module.</p>		

1.3. Auxiliary Equipment Used During Test

Adapter 1	:	Model: A653-1803500D Input: 100-240V~50/60Hz 1.5A Output: DC 18V, 3500mA
Adapter 2	:	Model: QX72W180350D2 Input: 100-240V~50/60Hz 1.5A Output: DC 18V, 3500mA

1.4. Description of Test Modes

To investigate the maximum EMI emission characteristics generates from EUT, the test system was pre-scanning tested base on the consideration of following EUT operation mode or test configuration mode which possible have effect on EMI emission level. Each of these EUT operation mode(s) or test configuration mode(s) mentioned above was evaluated respectively.

Pretest Mode	Description
Mode 1	CH00
Mode 2	CH19
Mode 3	CH39

Note:

(1) The measurements are performed at the highest, middle, lowest available channels.

1.5. List of channels

Channel	Freq. (MHz)	Channel	Freq. (MHz)	Channel	Freq. (MHz)	Channel	Freq. (MHz)	Channel	Freq. (MHz)
00	2402	09	2420	18	2438	27	2456	36	2474
01	2404	10	2422	19	2440	28	2458	37	2476
02	2406	11	2424	20	2442	29	2460	38	2478
03	2408	12	2426	21	2444	30	2462	39	2480
04	2410	13	2428	22	2446	31	2464		
05	2412	14	2430	23	2448	32	2466		
06	2414	15	2432	24	2450	33	2468		
07	2416	16	2434	25	2452	34	2470		
08	2418	17	2436	26	2454	35	2472		

Note:

1. The engineering test program was provided and the EUT was programmed to be in continuously transmitting mode.

1.6. Description Of Test Setup

CE

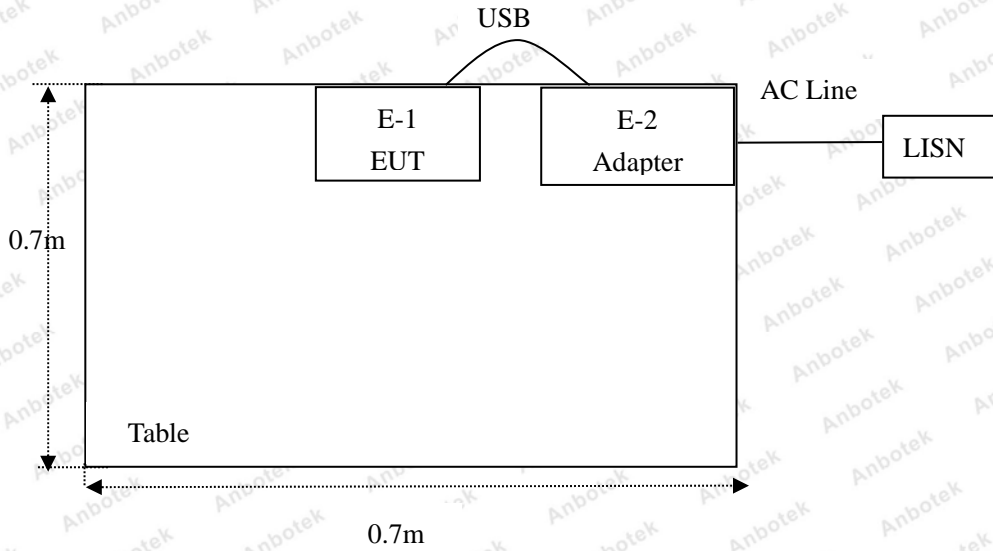

RE

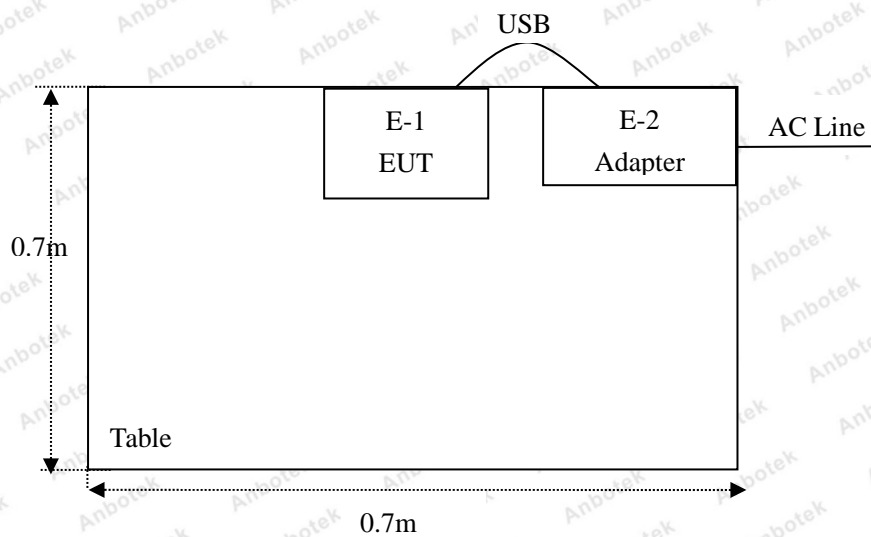

1.7. Test Equipment List

Item	Equipment	Manufacturer	Model No.	Serial No.	Last Cal.	Cal. Interval
1.	L.I.S.N. Artificial Mains Network	Rohde & Schwarz	ENV216	100055	Nov. 05, 2018	1 Year
2.	EMI Test Receiver	Rohde & Schwarz	ESPI3	101604	Nov. 05, 2018	1 Year
3.	RF Switching Unit	Compliance Direction	RSU-M2	38303	Nov. 05, 2018	1 Year
4.	Spectrum Analysis	Agilent	E4407B	US39390582	Nov. 05, 2018	1 Year
5.	MAX Spectrum Analysis	Agilent	N9020A	MY51170037	Nov. 05, 2018	1 Year
6.	Preamplifier	SKET Electronic	BK1G18G30 D	KD17503	Nov. 05, 2018	1 Year
7.	Double Ridged Horn Antenna	Instruments corporation	GTH-0118	351600	Nov. 20, 2018	1 Year
8.	Bilog Broadband Antenna	Schwarzbeck	VULB9163	VULB 9163-289	Nov. 19, 2018	1 Year
9.	Loop Antenna	Schwarzbeck	FMZB1519B	00053	Nov. 20, 2018	1 Year
10.	Horn Antenna	A-INFO	LB-180400-K F	J211060628	Nov. 20, 2018	1 Year
11.	Pre-amplifier	SONOMA	310N	186860	Nov. 05, 2018	1 Year
12.	EMI Test Software EZ-EMC	SHURPLE	N/A	N/A	N/A	N/A
13.	RF Test Control System	YIHENG	YH3000	2017430	Nov. 05, 2018	1 Year
14.	Power Sensor	DAER	RPR3006W	15I00041SN045	Nov. 05, 2018	1 Year
15.	Power Sensor	DAER	RPR3006W	15I00041SN046	Nov. 05, 2018	1 Year
16.	MXA Spectrum Analysis	Agilent	N9020A	MY51170037	Nov. 05, 2018	1 Year
17.	MXG RF Vector Signal Generator	Agilent	N5182A	MY48180656	Nov. 05, 2018	1 Year
18.	Signal Generator	Agilent	E4421B	MY41000743	Nov. 05, 2018	1 Year
19.	DC Power Supply	IVYTECH	IV3605	1804D360510	Apr. 02, 2018	1 Year
20.	Constant Temperature Humidity Chamber	ZHONGJIAN	ZJ-KHWS80 B	N/A	Nov. 01, 2018	1 Year

1.8. Measurement Uncertainty

Radiation Uncertainty	:	Ur = 3.9 dB (Horizontal)
		Ur = 3.8 dB (Vertical)
Conduction Uncertainty	:	Uc = 3.4 dB

1.9. Description of Test Facility

The test facility is recognized, certified, or accredited by the following organizations:

FCC-Registration No.: 184111

Shenzhen Anbotek Compliance Laboratory Limited, EMC Laboratory has been registered and fully described in a report filed with the (FCC) Federal Communications Commission. The acceptance letter from the FCC is maintained in our files. Registration No. 184111, July 31, 2017.

ISED-Registration No.: 8058A-1

Shenzhen Anbotek Compliance Laboratory Limited, EMC Laboratory has been registered and fully described in a report filed with the (ISED) Innovation, Science and Economic Development Canada. The acceptance letter from the ISED is maintained in our files. Registration 8058A-1, June 13, 2016.

Test Location

Shenzhen Anbotek Compliance Laboratory Limited.

1/F, Building D, Sogood Science and Technology Park, Sanwei community, Hangcheng Street, Bao'an District, Shenzhen, Guangdong, China.518102

2. Summary of Test Results

Standard Section	Test Item	Result
15.203/15.247(c)	Antenna Requirement	PASS
15.207	Conducted Emission	PASS
15.205/15.209	Spurious Emission	PASS
15.247(b)(3)	Conducted Peak Output Power	PASS
15.247(a)(2)	6dB Occupied Bandwidth	PASS
15.247(e)	Power Spectral Density	PASS
15.247(d)	Band Edge	PASS
Remark: "N/A" is an abbreviation for Not Applicable.		

3. Conducted Emission Test

3.1. Test Standard and Limit

Test Standard	FCC Part15 Section 15.207		
Test Limit	Frequency	Maximum RF Line Voltage (dBuV)	
		Quasi-peak Level	Average Level
	150kHz~500kHz	66 ~ 56 *	56 ~ 46 *
	500kHz~5MHz	56	46
5MHz~30MHz	60	50	

Remark: (1) *Decreasing linearly with logarithm of the frequency.
(2) The lower limit shall apply at the transition frequency.

3.2. Test Setup

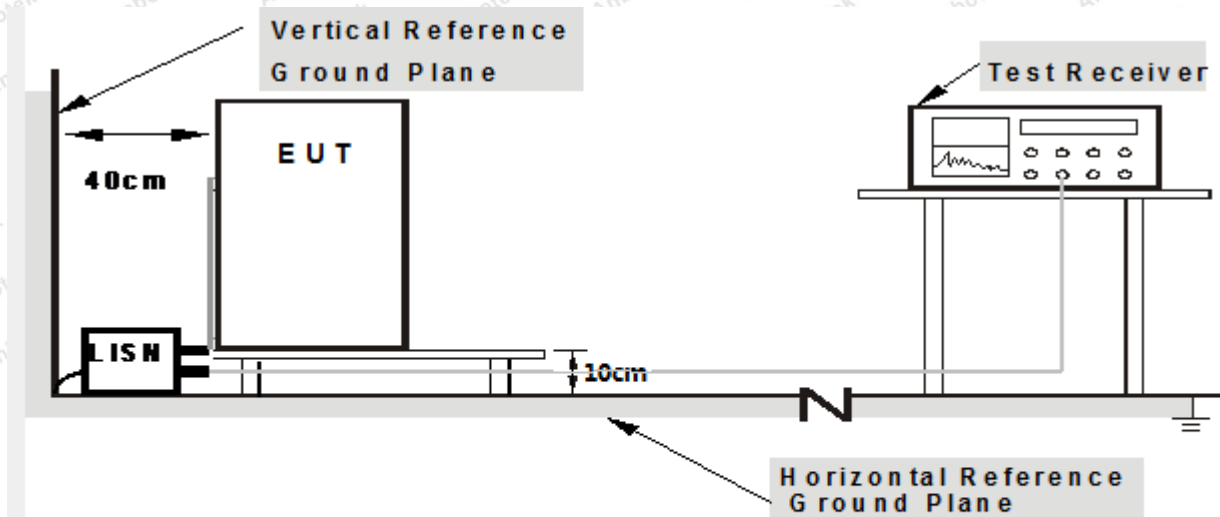

Note: 1.Support units were connected to second LISN.
2.Both of LISNs (AMN) are 80 cm from EUT and at least 80 from other units and other metal planes

3.3. Test Procedure

The EUT system is connected to the power mains through a line impedance stabilization network (L.I.S.N.). This provides a 50ohm coupling impedance for the EUT system. Please refer the block diagram of the test setup and photographs. Both sides of AC line are checked to find out the maximum conducted emission. In order to find the maximum emission levels, the relative positions of equipment and all of the interface cables shall be changed according to FCC ANSI C63.10-2013 on Conducted Emission Measurement.

The bandwidth of test receiver (ESCI) set at 9kHz.

The frequency range from 150kHz to 30MHz is checked.

3.4. Test Data

Please to see the following pages.

During the test, all the modes have been tested, and only the worst case is recorded in the report



Conducted Emission Test Data

Test Site: 1# Shielded Room
 Operating Condition: CH00
 Test Specification: AC 240V, 60Hz for adapter
 Comment: Live Line
 Tem.: 22.6°C Hum.: 42%
 Note: Adapter 1

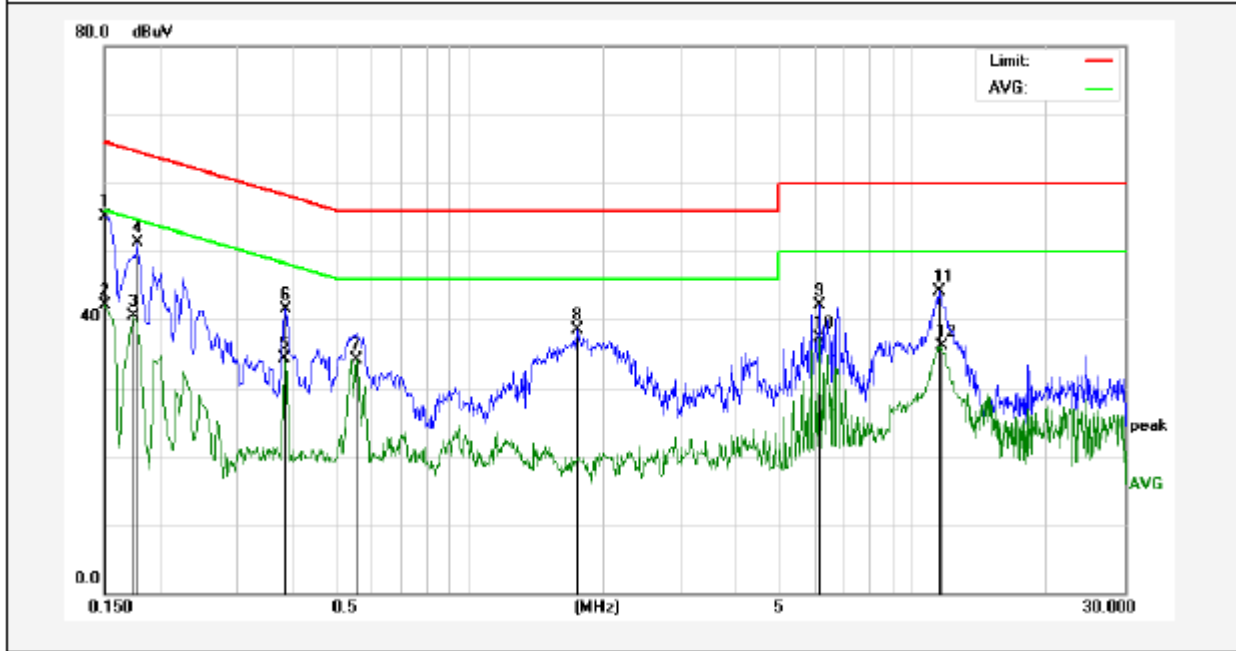

No.	Freq. (MHz)	Reading (dBuV)	Factor (dB)	Result (dBuV)	Limit dBuV	Over Limit (dB)	Detector	Remark
1	0.1499	35.25	19.90	55.15	66.00	-10.85	QP	
2	0.1499	22.23	19.90	42.13	56.00	-13.87	AVG	
3	0.1739	20.67	19.90	40.57	54.77	-14.20	AVG	
4	0.1779	31.46	19.90	51.36	64.58	-13.22	QP	
5	0.3820	14.30	19.93	34.23	48.23	-14.00	AVG	
6	0.3860	21.60	19.93	41.53	58.15	-16.62	QP	
7	0.5580	14.13	20.00	34.13	46.00	-11.87	AVG	
8	1.7459	18.45	20.13	38.58	56.00	-17.42	QP	
9	6.1379	21.78	20.24	42.02	60.00	-17.98	QP	
10	6.1379	17.01	20.24	37.25	50.00	-12.75	AVG	
11	11.4778	23.78	20.32	44.10	60.00	-15.90	QP	
12	11.5739	15.74	20.31	36.05	50.00	-13.95	AVG	

Conducted Emission Test Data

Test Site: 1# Shielded Room
 Operating Condition: CH00
 Test Specification: AC 240V, 60Hz for adapter
 Comment: Neutral Line
 Tem.: 22.6°C Hum.: 42%
 Note: Adapter 1

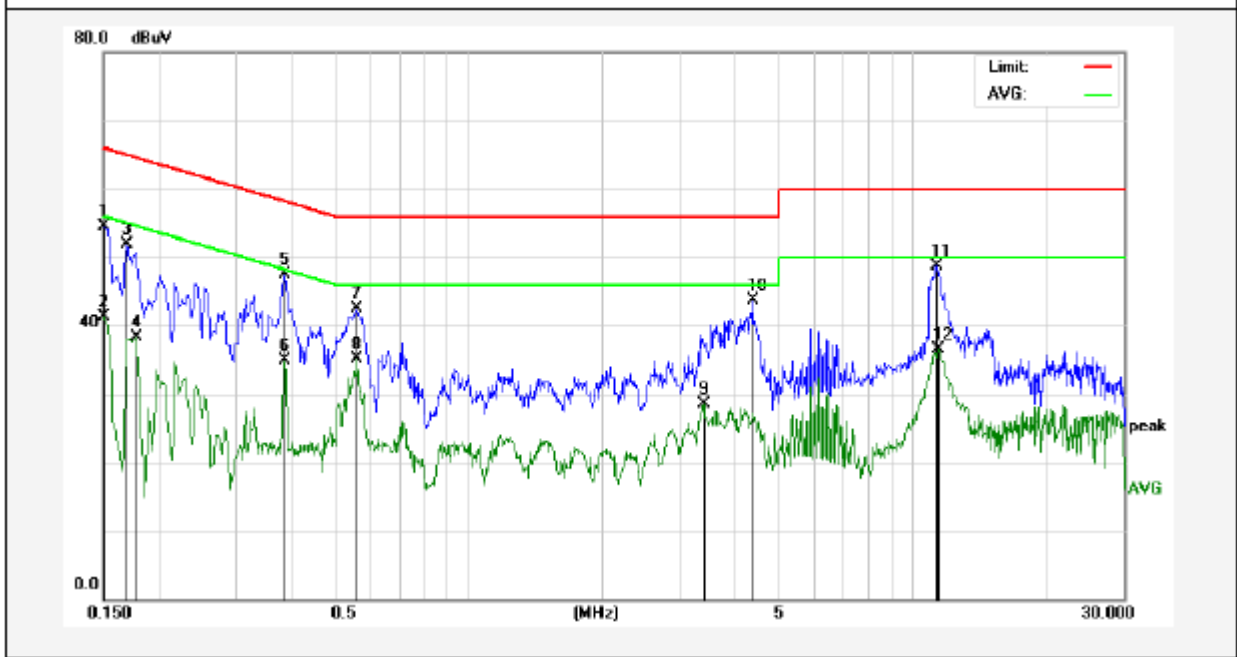

No.	Freq. (MHz)	Reading (dBuV)	Factor (dB)	Result (dBuV)	Limit dBuV	Over Limit (dB)	Detector	Remark
1	0.1499	34.64	19.90	54.54	66.00	-11.46	QP	
2	0.1499	21.47	19.90	41.37	56.00	-14.63	AVG	
3	0.1700	32.01	19.90	51.91	64.96	-13.05	QP	
4	0.1779	18.47	19.90	38.37	54.58	-16.21	AVG	
5	0.3860	27.58	19.93	47.51	58.15	-10.64	QP	
6	0.3860	15.01	19.93	34.94	48.15	-13.21	AVG	
7	0.5620	22.44	20.00	42.44	56.00	-13.56	QP	
8	0.5620	15.03	20.00	35.03	46.00	-10.97	AVG	
9	3.3820	8.38	20.17	28.55	46.00	-17.45	AVG	
10	4.3778	23.50	20.19	43.69	56.00	-12.31	QP	
11	11.3698	28.41	20.32	48.73	60.00	-11.27	QP	
12	11.4419	16.13	20.32	36.45	50.00	-13.55	AVG	

Conducted Emission Test Data

Test Site: 1# Shielded Room
 Operating Condition: CH00
 Test Specification: AC 120V, 60Hz for adapter
 Comment: Live Line
 Tem.: 22.6°C Hum.: 42%
 Note: Adapter 1

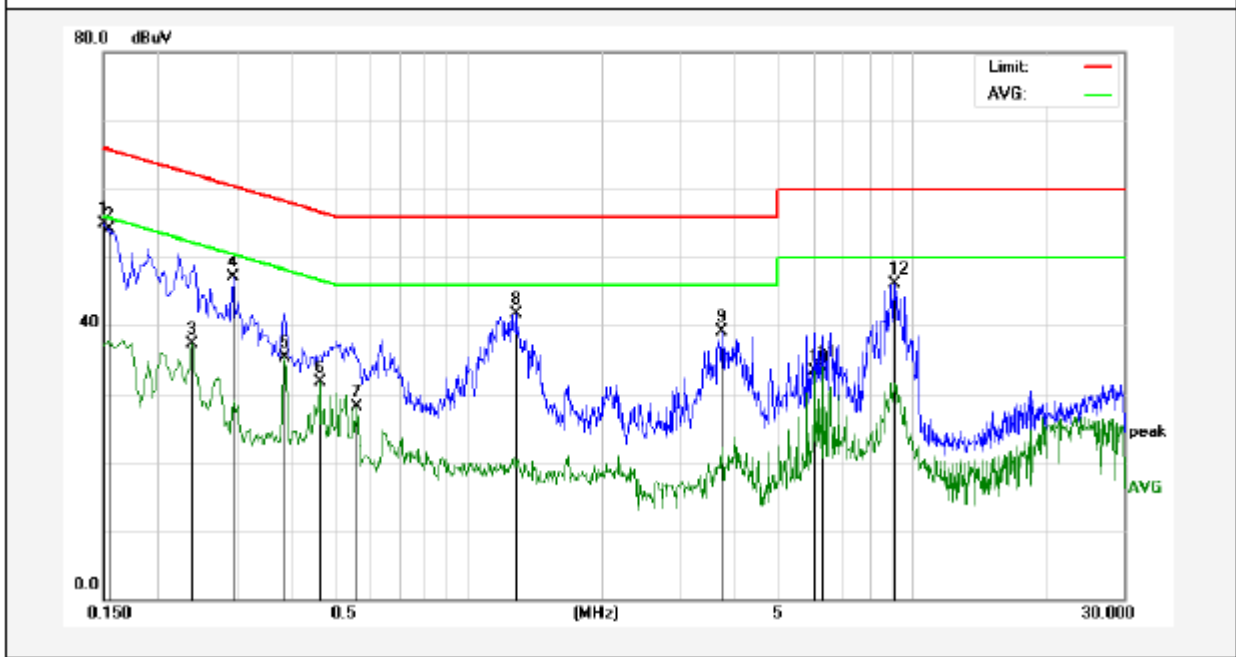

No.	Freq. (MHz)	Reading (dBuV)	Factor (dB)	Result (dBuV)	Limit dBuV	Over Limit (dB)	Detector	Remark
1	0.1499	35.08	19.90	54.98	66.00	-11.02	QP	
2	0.1547	34.23	19.90	54.13	65.74	-11.61	QP	
3	0.2379	17.51	19.89	37.40	52.17	-14.77	AVG	
4	0.2939	27.13	19.89	47.02	60.41	-13.39	QP	
5	0.3860	15.43	19.93	35.36	48.15	-12.79	AVG	
6	0.4620	11.70	19.96	31.66	46.66	-15.00	AVG	
7	0.5620	8.04	20.00	28.04	46.00	-17.96	AVG	
8	1.2820	21.61	20.13	41.74	56.00	-14.26	QP	
9	3.7259	18.93	20.17	39.10	56.00	-16.90	QP	
10	6.0458	13.11	20.23	33.34	50.00	-16.66	AVG	
11	6.3018	13.73	20.24	33.97	50.00	-16.03	AVG	
12	9.1178	25.77	20.32	46.09	60.00	-13.91	QP	

Conducted Emission Test Data

Test Site: 1# Shielded Room
 Operating Condition: CH00
 Test Specification: AC 120V, 60Hz for adapter
 Comment: Neutral Line
 Tem.: 22.6°C Hum.: 42%
 Note: Adapter 1

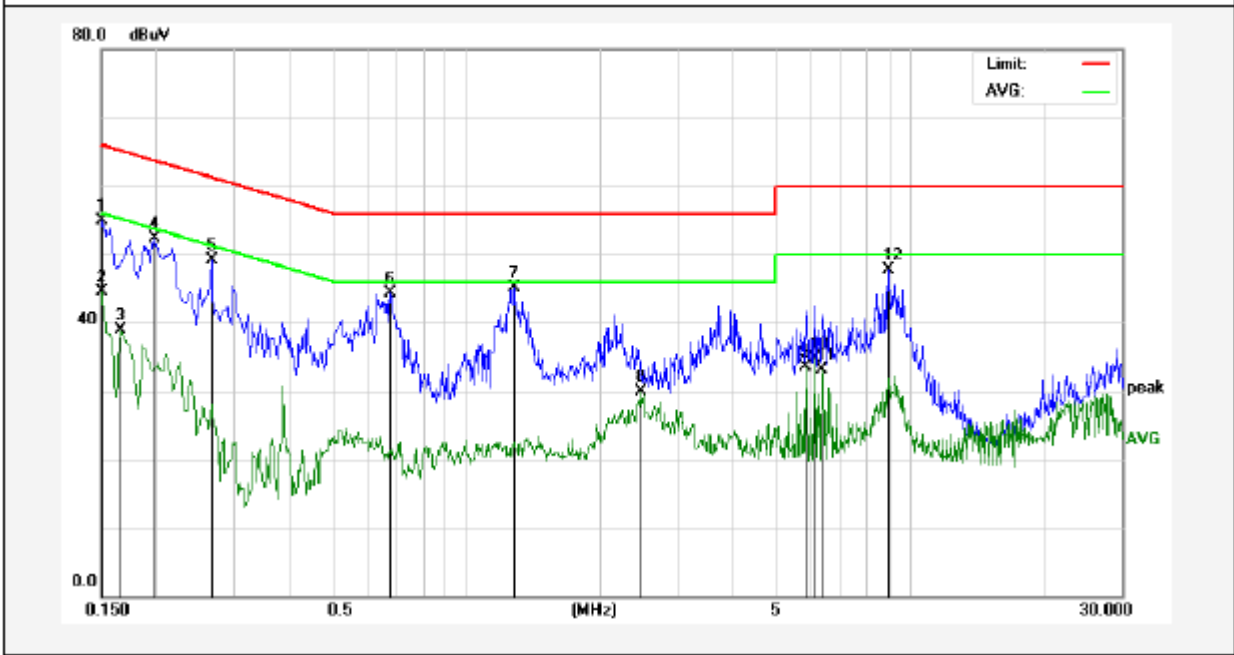

No.	Freq. (MHz)	Reading (dBUV)	Factor (dB)	Result (dBUV)	Limit dBUV	Over Limit (dB)	Detector	Remark
1	0.1499	35.09	19.90	54.99	66.00	-11.01	QP	
2	0.1499	24.52	19.90	44.42	56.00	-11.58	AVG	
3	0.1660	19.00	19.90	38.90	55.15	-16.25	AVG	
4	0.1980	32.41	19.90	52.31	63.69	-11.38	QP	
5	0.2660	29.25	19.89	49.14	61.24	-12.10	QP	
6	0.6740	24.20	20.03	44.23	56.00	-11.77	QP	
7	1.2820	24.96	20.13	45.09	56.00	-10.91	QP	
8	2.4620	9.68	20.15	29.83	46.00	-16.17	AVG	
9	5.8338	13.27	20.23	33.50	50.00	-16.50	AVG	
10	6.0938	14.40	20.24	34.64	50.00	-15.36	AVG	
11	6.3498	12.83	20.24	33.07	50.00	-16.93	AVG	
12	8.9539	27.42	20.31	47.73	60.00	-12.27	QP	

Conducted Emission Test Data

Test Site: 1# Shielded Room
 Operating Condition: CH00
 Test Specification: AC 240V, 60Hz for adapter
 Comment: Live Line
 Tem.: 22.6°C Hum.: 42%
 Note: Adapter 2

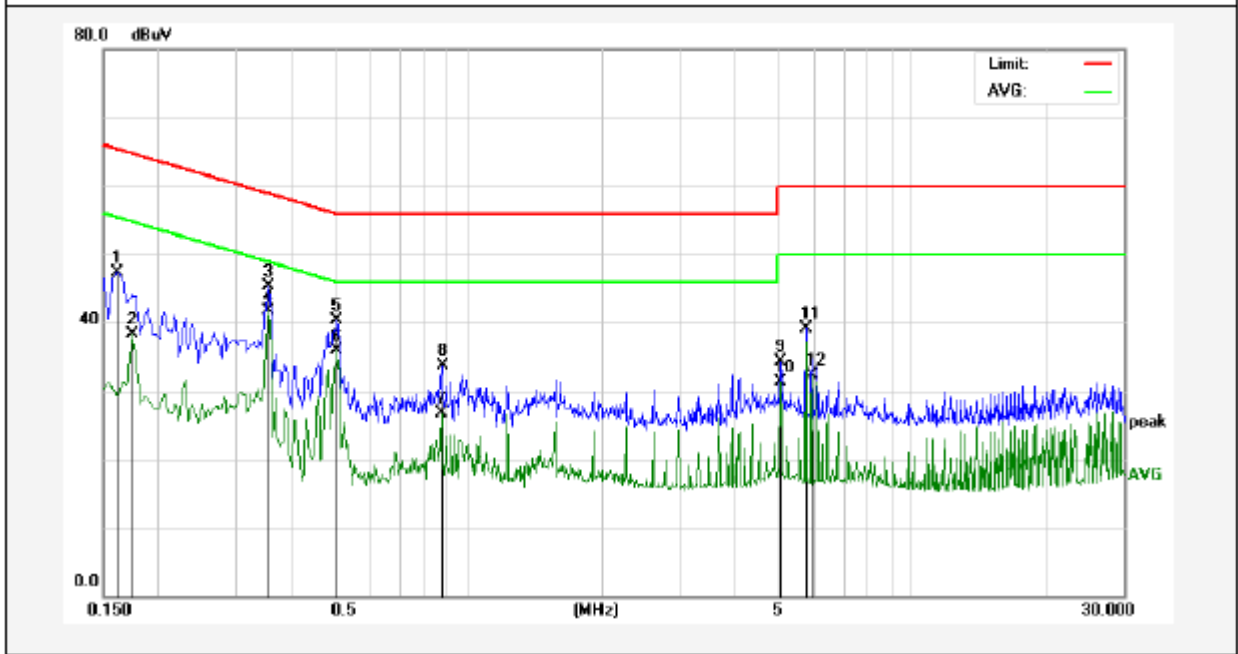

No.	Freq. (MHz)	Reading (dBuV)	Factor (dB)	Result (dBuV)	Limit dBuV	Over Limit (dB)	Detector	Remark
1	0.1620	27.49	19.90	47.39	65.36	-17.97	QP	
2	0.1737	18.47	19.90	38.37	54.78	-16.41	AVG	
3	0.3537	25.31	19.91	45.22	58.87	-13.65	QP	
4	0.3537	21.88	19.91	41.79	48.87	-7.08	AVG	
5	0.5060	20.25	19.98	40.23	56.00	-15.77	QP	
6	0.5060	15.84	19.98	35.82	46.00	-10.18	AVG	
7	0.8699	6.63	20.09	26.72	46.00	-19.28	AVG	
8	0.8739	13.67	20.09	33.76	56.00	-22.24	QP	
9	5.0579	14.05	20.21	34.26	60.00	-25.74	QP	
10	5.0579	11.00	20.21	31.21	50.00	-18.79	AVG	
11	5.7538	18.97	20.23	39.20	60.00	-20.80	QP	
12	5.9298	12.12	20.23	32.35	50.00	-17.65	AVG	

Conducted Emission Test Data

Test Site: 1# Shielded Room
 Operating Condition: CH00
 Test Specification: AC 240V, 60Hz for adapter
 Comment: Neutral Line
 Tem.: 22.6°C Hum.: 42%
 Note: Adapter 2

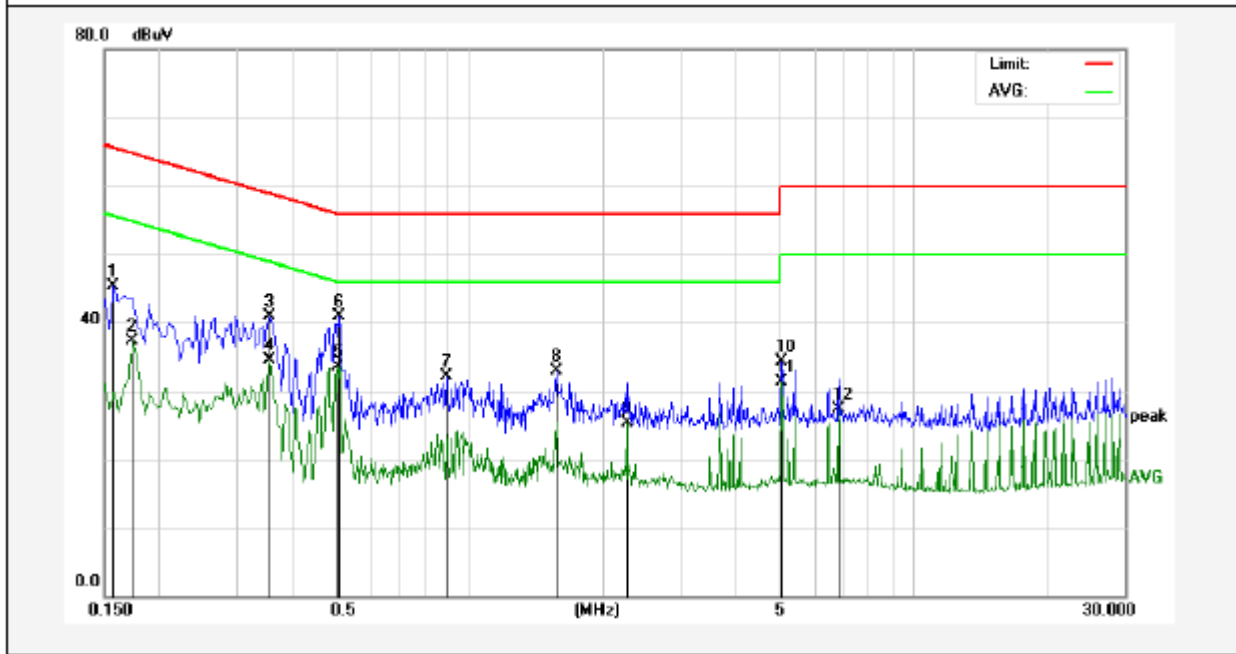

No.	Freq. (MHz)	Reading (dBuV)	Factor (dB)	Result (dBuV)	Limit dBuV	Over Limit (dB)	Detector	Remark
1	0.1580	25.43	19.90	45.33	65.56	-20.23	QP	
2	0.1737	17.50	19.90	37.40	54.78	-17.38	AVG	
3	0.3537	20.99	19.91	40.90	58.87	-17.97	QP	
4	0.3537	14.67	19.91	34.58	48.87	-14.29	AVG	
5	0.5020	13.60	19.98	33.58	46.00	-12.42	AVG	
6	0.5100	20.87	19.98	40.85	56.00	-15.15	QP	
7	0.8860	12.01	20.09	32.10	56.00	-23.90	QP	
8	1.5700	12.79	20.13	32.92	56.00	-23.08	QP	
9	2.2659	5.21	20.15	25.36	46.00	-20.64	AVG	
10	5.0579	14.17	20.21	34.38	60.00	-25.62	QP	
11	5.0579	11.02	20.21	31.23	50.00	-18.77	AVG	
12	6.8018	6.96	20.25	27.21	50.00	-22.79	AVG	

Conducted Emission Test Data

Test Site: 1# Shielded Room
 Operating Condition: CH00
 Test Specification: AC 120V, 60Hz for adapter
 Comment: Live Line
 Tem.: 22.6°C Hum.: 42%
 Note: Adapter 2

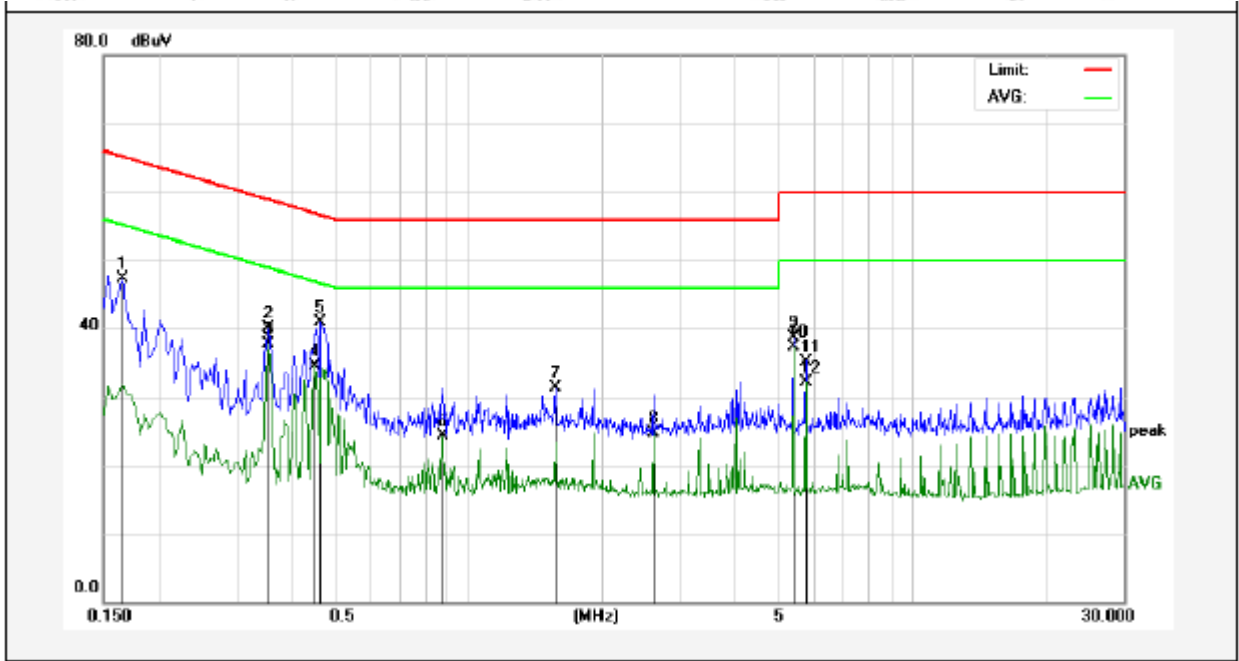

No.	Freq. (MHz)	Reading (dBuV)	Factor (dB)	Result (dBuV)	Limit dBuV	Over Limit (dB)	Detector	Remark
1	0.1660	27.31	19.90	47.21	65.15	-17.94	QP	
2	0.3537	20.14	19.91	40.05	58.87	-18.82	QP	
3	0.3537	17.83	19.91	37.74	48.87	-11.13	AVG	
4	0.4500	14.46	19.96	34.42	46.87	-12.45	AVG	
5	0.4660	20.87	19.96	40.83	56.58	-15.75	QP	
6	0.8739	4.25	20.09	24.34	46.00	-21.66	AVG	
7	1.5700	11.23	20.13	31.36	56.00	-24.64	QP	
8	2.6139	4.65	20.15	24.80	46.00	-21.20	AVG	
9	5.4058	18.46	20.22	38.68	60.00	-21.32	QP	
10	5.4058	17.07	20.22	37.29	50.00	-12.71	AVG	
11	5.7579	14.97	20.23	35.20	60.00	-24.80	QP	
12	5.7579	11.90	20.23	32.13	50.00	-17.87	AVG	

Conducted Emission Test Data

Test Site: 1# Shielded Room
 Operating Condition: CH00
 Test Specification: AC 120V, 60Hz for adapter
 Comment: Neutral Line
 Tem.: 22.6°C Hum.: 42%
 Note: Adapter 2

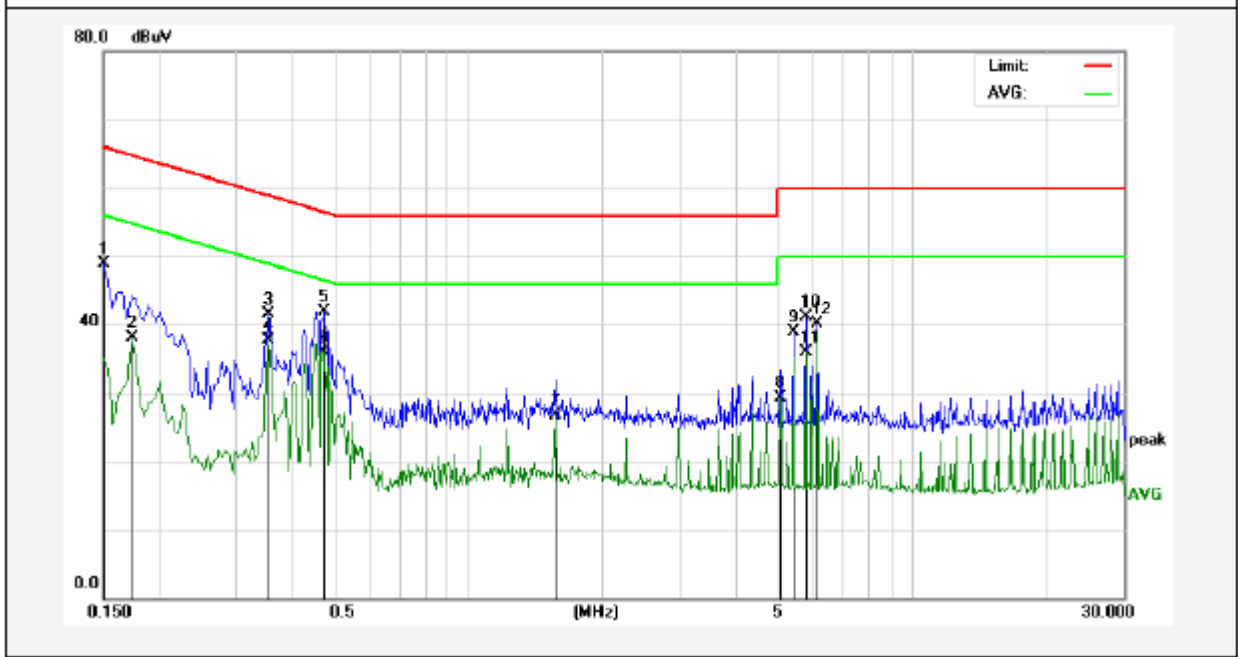

No.	Freq. (MHz)	Reading (dBuV)	Factor (dB)	Result (dBuV)	Limit dBuV	Over Limit (dB)	Detector	Remark
1	0.1499	29.10	19.90	49.00	66.00	-17.00	QP	
2	0.1737	18.23	19.90	38.13	54.78	-16.65	AVG	
3	0.3537	21.61	19.91	41.52	58.87	-17.35	QP	
4	0.3537	17.82	19.91	37.73	48.87	-11.14	AVG	
5	0.4737	22.03	19.97	42.00	56.45	-14.45	QP	
6	0.4737	15.98	19.97	35.95	46.45	-10.50	AVG	
7	1.5700	6.53	20.13	26.66	46.00	-19.34	AVG	
8	5.0579	9.12	20.21	29.33	50.00	-20.67	AVG	
9	5.4058	18.61	20.22	38.83	60.00	-21.17	QP	
10	5.7538	20.91	20.23	41.14	60.00	-18.86	QP	
11	5.7538	15.67	20.23	35.90	50.00	-14.10	AVG	
12	6.1059	19.92	20.24	40.16	60.00	-19.84	QP	

4. Radiation Spurious Emission and Band Edge

4.1. Test Standard and Limit

Test Standard	FCC Part15 C Section 15.209 and 15.205				
Test Limit	Frequency (MHz)	Field strength (microvolt/meter)	Limit (dBuV/m)	Remark	Measurement distance (m)
	0.009MHz~0.490MHz	2400/F(kHz)	-	-	300
	0.490MHz-1.705MHz	24000/F(kHz)	-	-	30
	1.705MHz-30MHz	30	-	-	30
	30MHz~88MHz	100	40.0	Quasi-peak	3
	88MHz~216MHz	150	43.5	Quasi-peak	3
	216MHz~960MHz	200	46.0	Quasi-peak	3
	960MHz~1000MHz	500	54.0	Quasi-peak	3
	Above 1000MHz	500	54.0	Average	3
-		74.0	Peak	3	

Remark:

- (1)The lower limit shall apply at the transition frequency.
- (2) 15.35(b), Unless otherwise specified, the limit on peak radio frequency emissions is 20dB above the maximum permitted average emission limit applicable to the equipment under test. This peak limit applies to the total peak emission level radiated by the device.

4.2. Test Setup

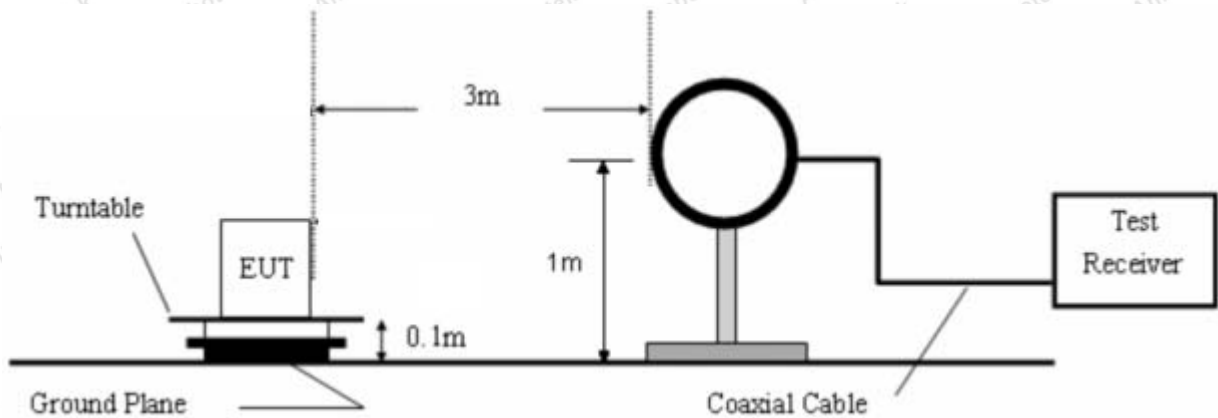

Figure 1. Below 30MHz

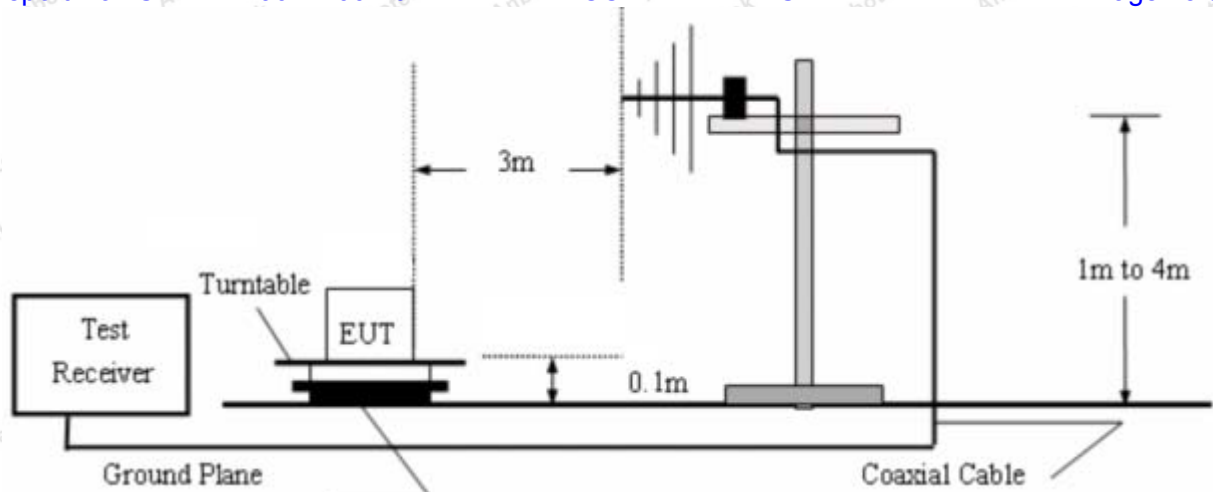

Figure 2. 30MHz to 1GHz

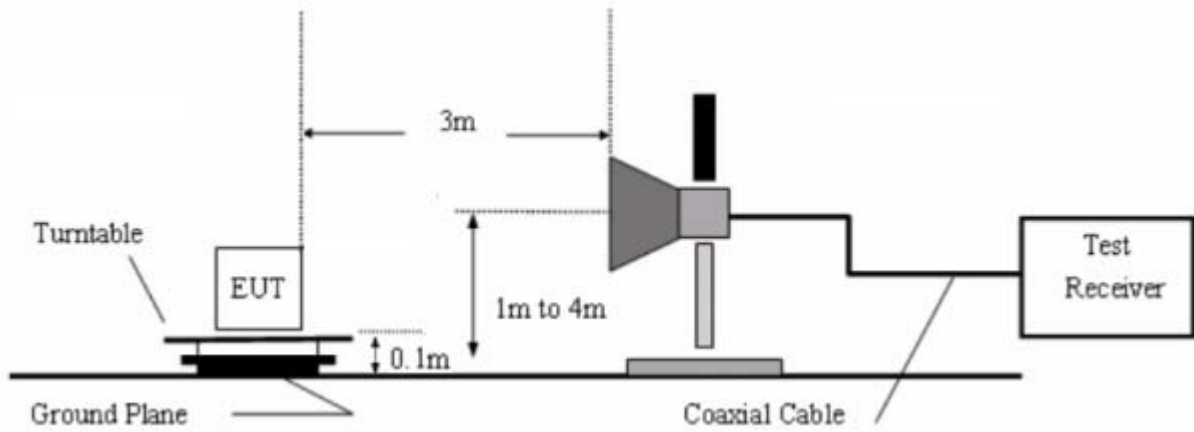

Figure 3. Above 1 GHz

4.3. Test Procedure

For below 1GHz: The EUT is placed on a turntable, which is 0.1m above the ground plane.

For above 1GHz: The EUT is placed on a turntable, which is 0.1m above the ground plane.

The turn table can rotate 360 degrees to determine the position of the maximum emission level. The EUT is set 3 meters away from the receiving antenna which is mounted on a antenna tower. The antenna can be moved up and down from 1 to 4 meters to find out the maximum emission level. Rotated the EUT through three orthogonal axes to determine the maximum emissions, both horizontal and vertical polarization of the antenna are set on test. The EUT is tested in 9*6*6 Chamber. The device is evaluated in xyz orientation.

For the radiated emission test above 1GHz:

Place the measurement antenna away from each area of the EUT determined to be a source of emissions at the specified measurement distance, while keeping the measurement antenna aimed at the source of emissions at each frequency of significant emissions, with polarization oriented for maximum response. The measurement antenna may have to be higher or lower than the EUT, depending on the radiation pattern of the emission and staying aimed at the emission source for receiving the maximum signal. The final measurement antenna elevation shall be that which maximizes the emissions. The

measurement antenna elevation for maximum emissions shall be restricted to a range of heights of from 1 m to 4 m above the ground or reference ground plane.

For 9kHz to 150kHz, Set the spectrum analyzer as:

RBW = 200Hz, VBW = 1kHz, Detector= Quasi-Peak, Trace mode= Max hold, Sweep- auto couple.

For 150kHz to 30MHz, Set the spectrum analyzer as:

RBW = 9kHz, VBW = 30kHz, Detector= Quasi-Peak, Trace mode= Max hold, Sweep- auto couple.

For 30MHz to 1000MHz, Set the spectrum analyzer as:

RBW = 100kHz, VBW = 300kHz, Detector= Quasi-Peak, Trace mode= Max hold, Sweep- auto couple.

For above 1GHz, Set the spectrum analyzer as:

RBW = 1MHz, VBW = 1MHz, Detector= Peak, Trace mode= Max hold, Sweep- auto couple.

RBW = 1MHz, VBW = 10Hz, Detector= Average, Trace mode= Max hold, Sweep- auto couple.

4.4. Test Data

PASS

During the test, pre-scan the GFSK modulation, and found the GFSK modulation Middle channel which is the worst case, only the worst case is recorded in the report.

The test results of 9kHz-30MHz was attenuated more than 20dB below the permissible limits, so the results don't record in the report.

Test Results (30~1000MHz)

Job No.: SZAWW190212001-02

Temp.(°C)/Hum.(%RH): 23.8°C/54%RH

Standard: FCC PART 15C

Power Source: AC 120V, 60Hz for adapter

Test Mode: Mode 2

Polarization: Horizontal

Note: Adapter 1

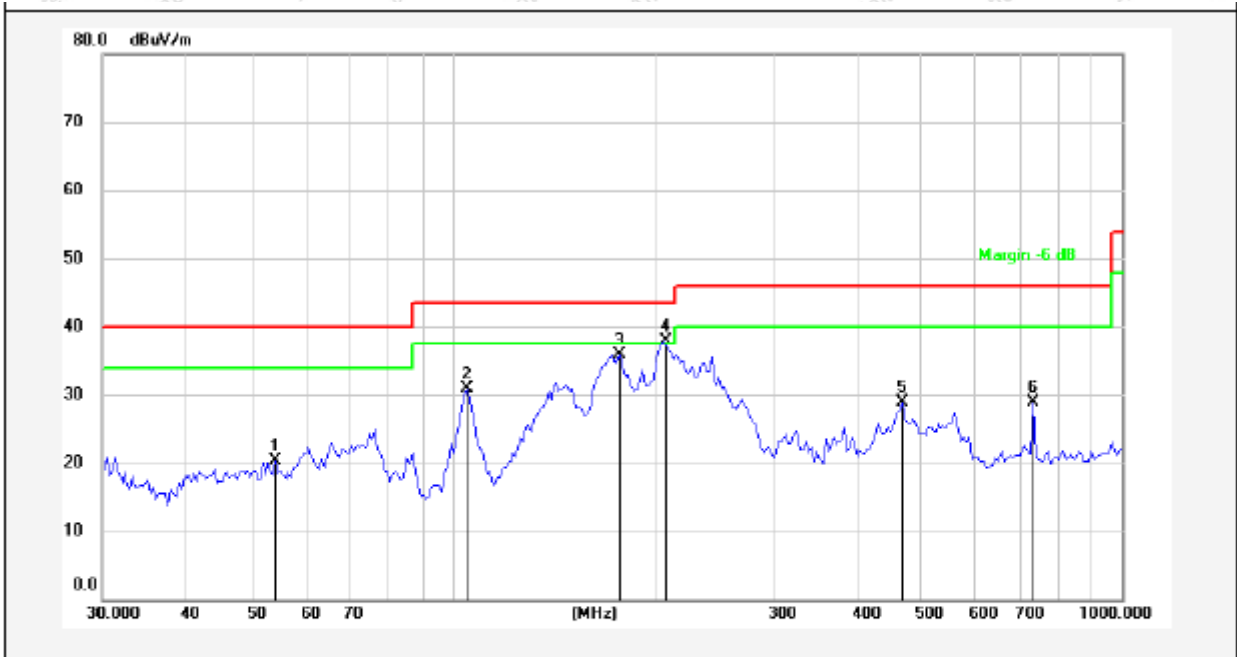

No.	Freq. (MHz)	Reading (dBuV)	Factor (dB/m)	Result (dBuV/m)	Limit (dBuV/m)	Over Limit (dB)	Detector	Height (cm)	degree (deg)	Remark
1	54.4515	36.18	-15.95	20.23	40.00	-19.77	QP	300	215	
2	105.0871	51.91	-20.93	30.98	43.50	-12.52	QP	300	67	
3	177.8206	57.22	-21.35	35.87	43.50	-7.63	QP	300	169	
4	206.3976	58.54	-20.62	37.92	43.50	-5.58	QP	300	354	
5	470.5230	42.69	-13.88	28.81	46.00	-17.19	QP	300	95	
6	735.7802	38.78	-9.78	29.00	46.00	-17.00	QP	300	249	

Test Results (30~1000MHz)

Job No.: SZAWW190212001-02 Temp.(°C)/Hum.(%RH): 23.8°C/54%RH
 Standard: FCC PART 15C Power Source: AC 120V, 60Hz for adapter
 Test Mode: Mode 2 Polarization: Vertical
 Note: Adapter 1

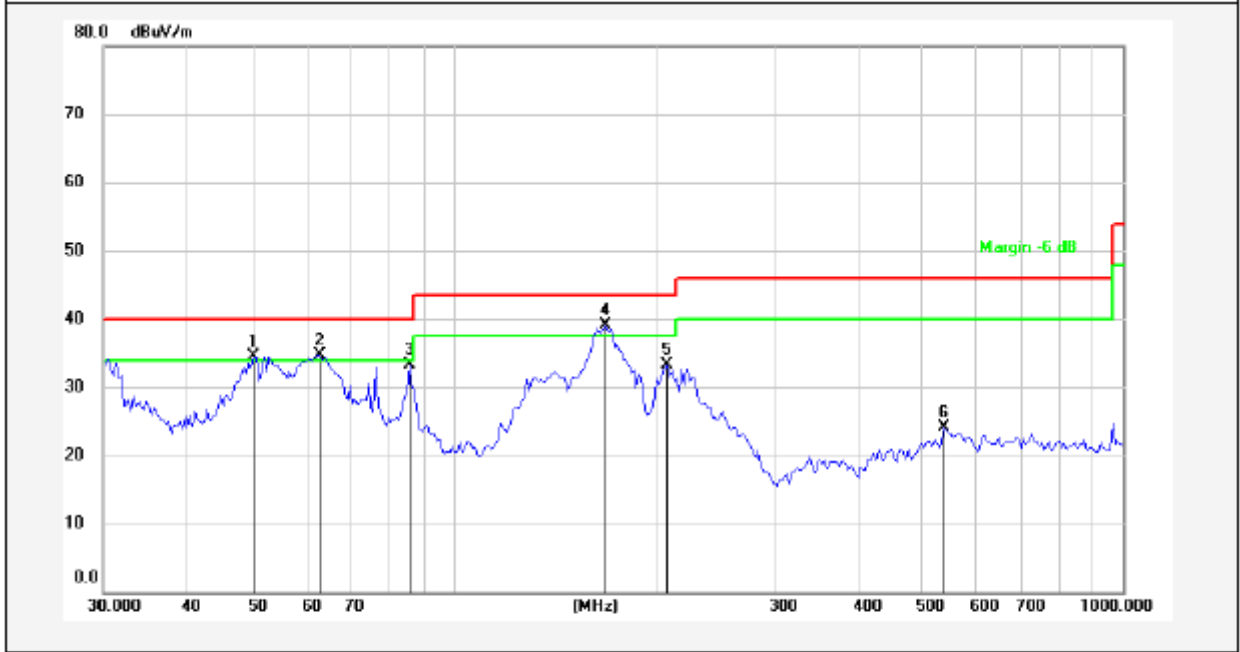

No.	Freq. (MHz)	Reading (dBuV)	Factor (dB/m)	Result (dBuV/m)	Limit (dBuV/m)	Over Limit (dB)	Detector	Height (cm)	degree (deg)	Remark
1	50.3205	49.44	-14.86	34.58	40.00	-5.42	QP	300	136	
2	62.6507	50.86	-16.22	34.64	40.00	-5.36	QP	300	55	
3	85.8983	50.59	-17.29	33.30	40.00	-6.70	QP	300	69	
4	168.7093	57.36	-18.21	39.15	43.50	-4.35	QP	300	248	
5	208.2148	49.57	-16.23	33.34	43.50	-10.16	QP	300	351	
6	541.3724	36.28	-12.12	24.16	46.00	-21.84	QP	300	274	

Test Results (30~1000MHz)

Job No.: SZAWW190212001-02

Temp.(°C)/Hum.(%RH): 23.8°C/54%RH

Standard: FCC PART 15C

Power Source: AC 240V, 60Hz for adapter

Test Mode: Mode 2

Polarization: Horizontal

Note: Adapter 1

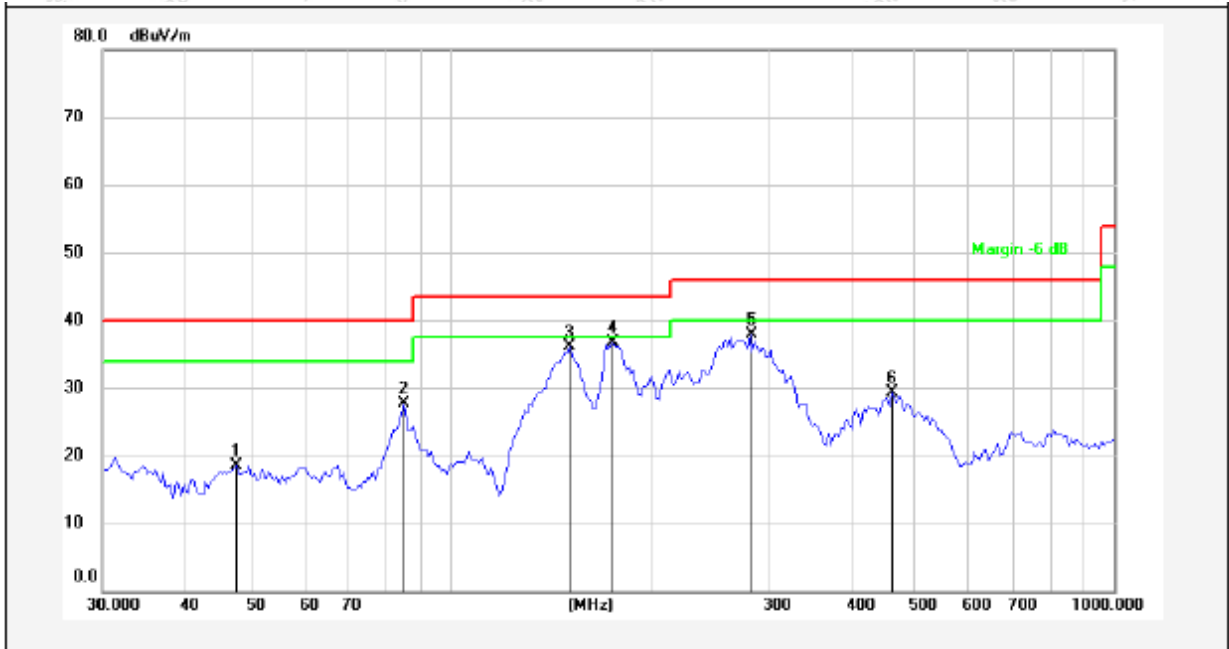

No.	Freq. (MHz)	Reading (dBuV)	Factor (dB/m)	Result (dBuV/m)	Limit (dBuV/m)	Over Limit (dB)	Detector	Height (cm)	degree (deg)	Remark
1	47.7421	34.17	-15.73	18.44	40.00	-21.56	QP	300	119	
2	85.1486	48.13	-20.48	27.65	40.00	-12.35	QP	300	186	
3	151.8632	58.96	-22.94	36.02	43.50	-7.48	QP	300	348	
4	176.2684	57.93	-21.31	36.62	43.50	-6.88	QP	300	249	
5	282.9852	57.01	-19.07	37.94	46.00	-8.06	QP	300	52	
6	462.3455	43.35	-14.09	29.26	46.00	-16.74	QP	300	177	

Test Results (30~1000MHz)

Job No.: SZAWW190212001-02

Temp.(°C)/Hum.(%RH): 23.8°C/54%RH

Standard: FCC PART 15C

Power Source: AC 240V, 60Hz for adapter

Test Mode: Mode 2

Polarization: Vertical

Note: Adapter 1

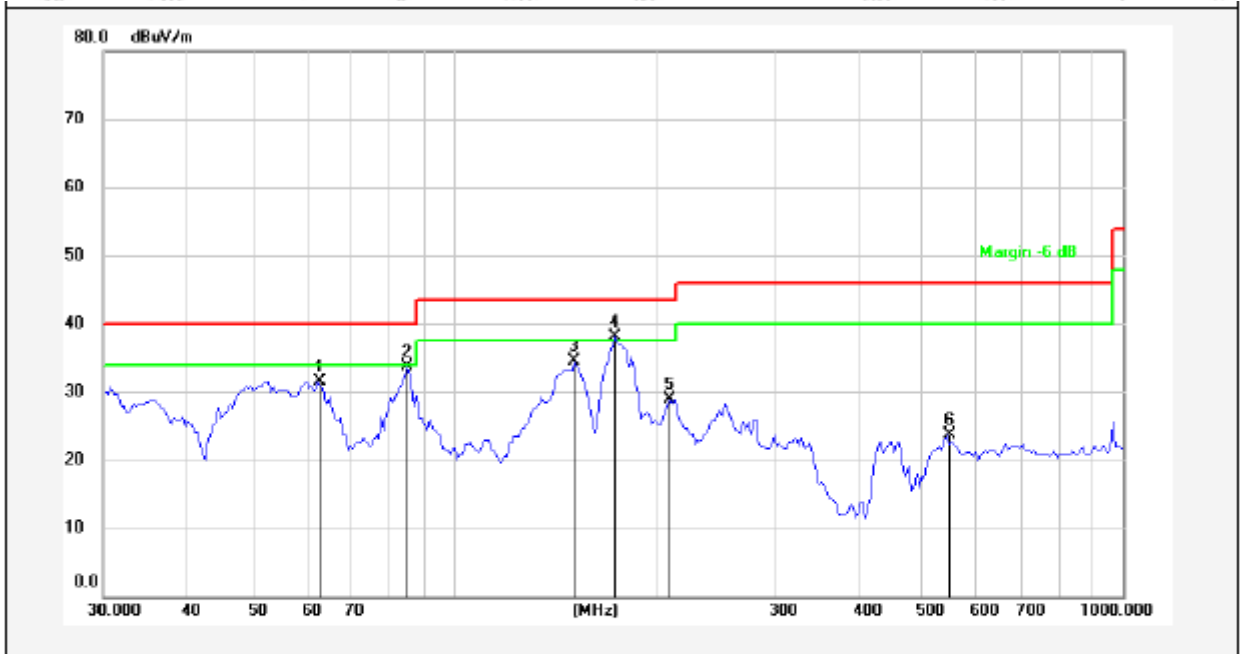

No.	Freq. (MHz)	Reading (dBuV)	Factor (dB/m)	Result (dBuV/m)	Limit (dBuV/m)	Over Limit (dB)	Detector	Height (cm)	degree (deg)	Remark
1	62.6507	47.69	-16.22	31.47	40.00	-8.53	QP	300	137	
2	85.1486	51.09	-17.39	33.70	40.00	-6.30	QP	300	65	
3	151.8632	53.42	-18.94	34.48	43.50	-9.02	QP	300	249	
4	174.7300	55.92	-17.80	38.12	43.50	-5.38	QP	300	63	
5	210.0482	45.11	-16.16	28.95	43.50	-14.55	QP	300	259	
6	546.1393	35.70	-12.00	23.70	46.00	-22.30	QP	300	346	

Test Results (30~1000MHz)

Job No.: SZAWW190212001-02
Standard: FCC PART 15C
Test Mode: Mode 2
Note: Adapter 2

Temp.(°C)/Hum.(%RH): 23.8°C/54%RH
Power Source: AC 120V, 60Hz for adapter
Polarization: Horizontal

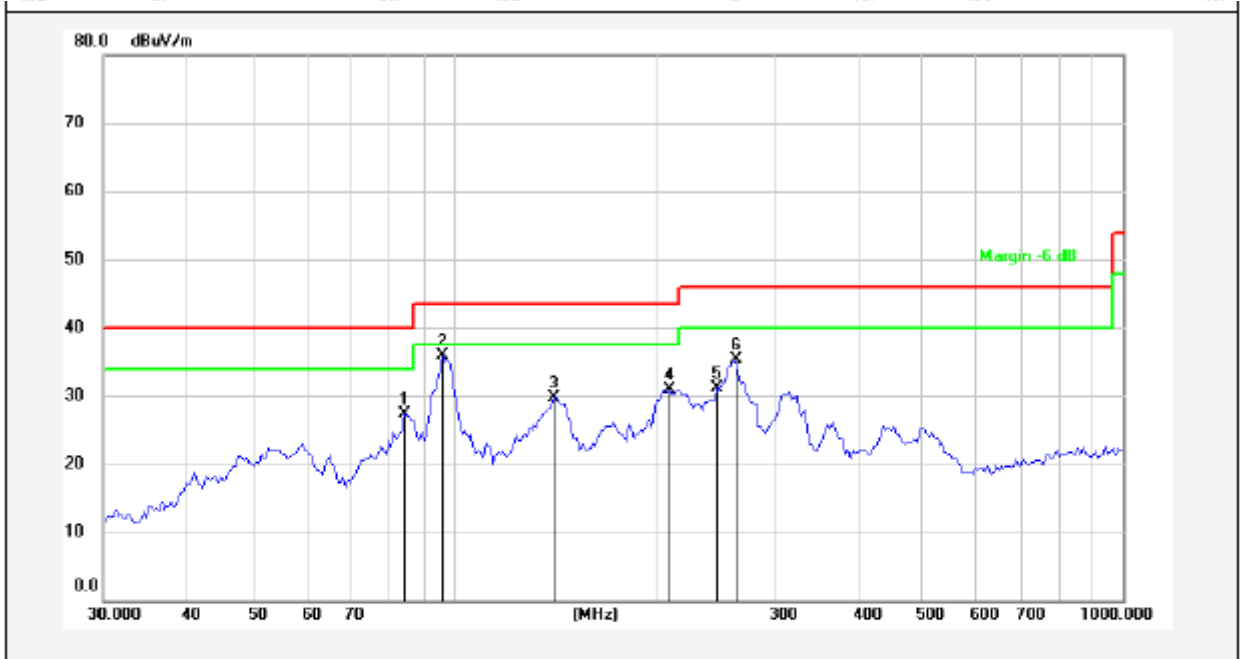

No.	Freq. (MHz)	Reading (dBuV)	Factor (dB/m)	Result (dBuV/m)	Limit (dBuV/m)	Over Limit (dB)	Detector	Height (cm)	degree (deg)	Remark
1	84.4054	48.00	-20.62	27.38	40.00	-12.62	QP	300	0	
2	96.2672	56.72	-20.75	35.97	43.50	-7.53	QP	300	74	
3	141.5777	53.00	-23.20	29.80	43.50	-13.70	QP	300	152	
4	210.0482	51.61	-20.67	30.94	43.50	-12.56	QP	300	214	
5	248.1165	50.33	-19.13	31.20	46.00	-14.80	QP	300	296	
6	261.5164	55.03	-19.70	35.33	46.00	-10.67	QP	300	360	

Test Results (30~1000MHz)

Job No.: SZAWW190212001-02 Temp.(°C)/Hum.(%RH): 23.8°C/54%RH
 Standard: FCC PART 15C Power Source: AC 120V, 60Hz for adapter
 Test Mode: Mode 2 Polarization: Vertical
 Note: Adapter 2

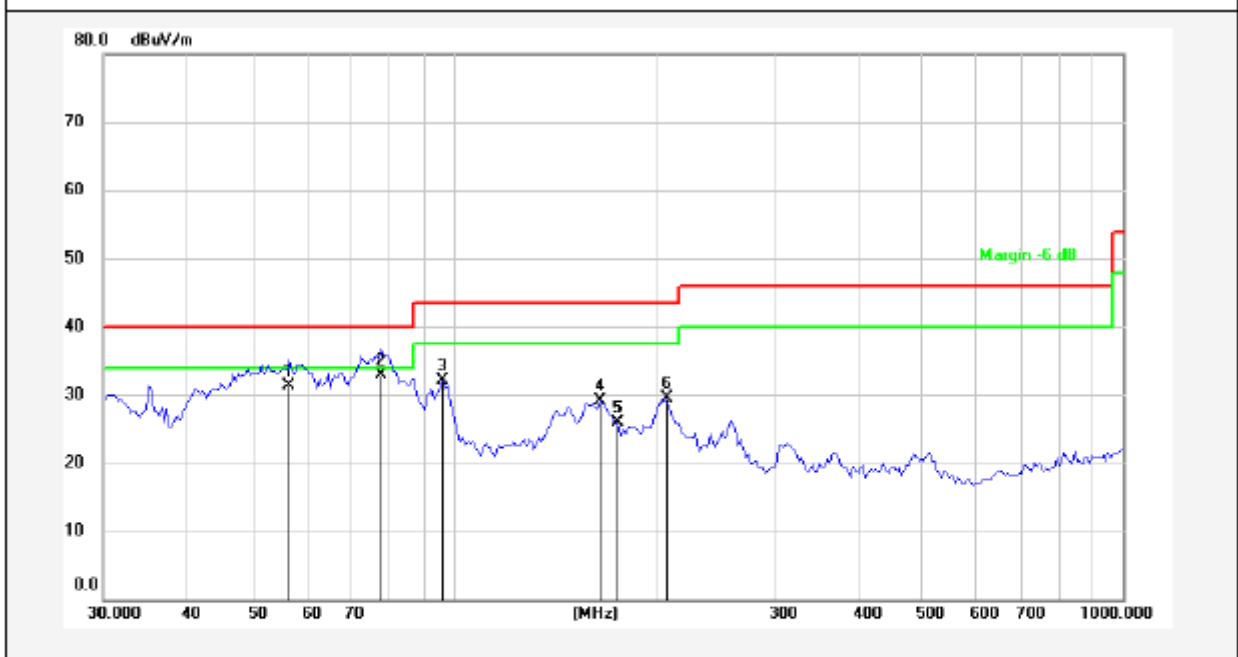

No.	Freq. (MHz)	Reading (dBuV)	Factor (dB/m)	Result (dBuV/m)	Limit (dBuV/m)	Over Limit (dB)	Detector	Height (cm)	degree (deg)	Remark
1	56.8914	46.35	-15.08	31.27	40.00	-8.73	QP	300	0	
2	78.0020	52.46	-19.51	32.95	40.00	-7.05	QP	300	74	
3	96.2672	46.87	-14.75	32.12	43.50	-11.38	QP	300	152	
4	165.7771	47.41	-18.31	29.10	43.50	-14.40	QP	300	211	
5	176.2686	43.59	-17.69	25.90	43.50	-17.60	QP	300	279	
6	206.3976	45.90	-16.30	29.60	43.50	-13.90	QP	300	360	

Test Results (30~1000MHz)

Job No.: SZAWW190212001-02

Temp.(°C)/Hum.(%RH): 23.8°C/54%RH

Standard: FCC PART 15C

Power Source: AC 240V, 60Hz for adapter

Test Mode: Mode 2

Polarization: Horizontal

Note: Adapter 2

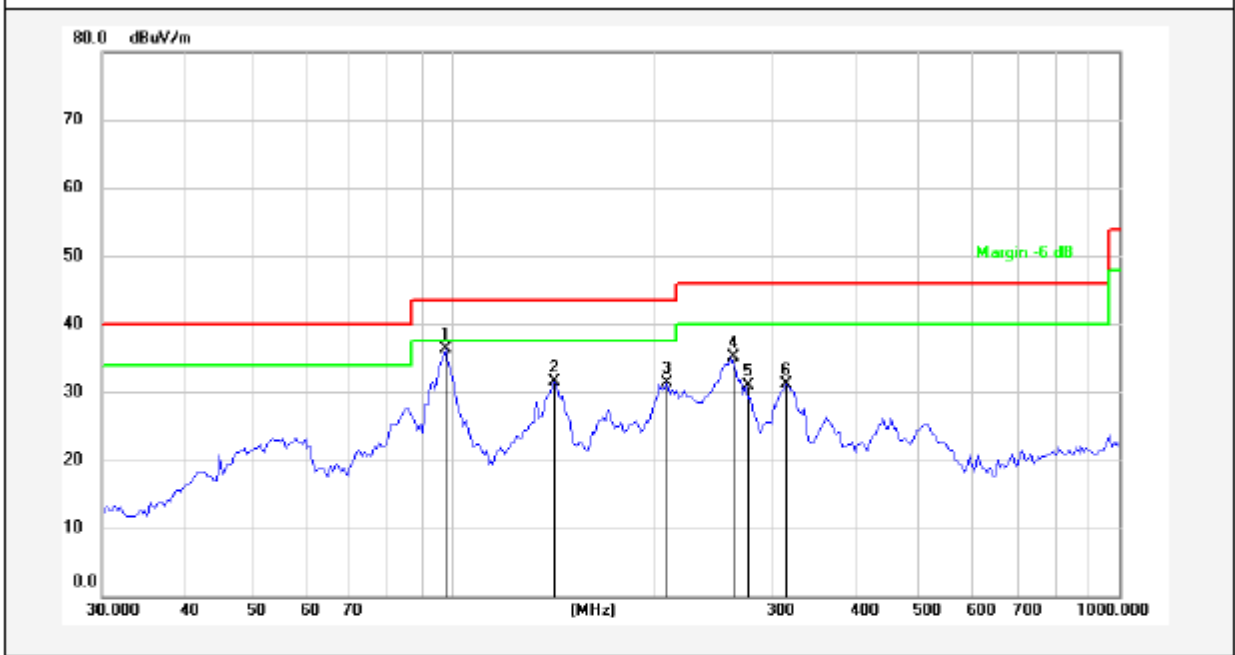

No.	Freq. (MHz)	Reading (dBuV)	Factor (dB/m)	Result (dBuV/m)	Limit (dBuV/m)	Over Limit (dB)	Detector	Height (cm)	degree (deg)	Remark
1	97.9699	56.85	-20.64	36.21	43.50	-7.29	QP	300	0	
2	142.8243	54.67	-23.18	31.49	43.50	-12.01	QP	300	74	
3	210.0482	52.01	-20.67	31.34	43.50	-12.16	QP	300	151	
4	261.5164	54.85	-19.70	35.15	46.00	-10.85	QP	300	211	
5	275.6399	50.14	-19.27	30.87	46.00	-15.13	QP	300	295	
6	317.1445	47.88	-16.80	31.08	46.00	-14.92	QP	300	360	

Test Results (30~1000MHz)

Job No.: SZAWW190212001-02 Temp.(°C)/Hum.(%RH): 23.8°C/54%RH
 Standard: FCC PART 15C Power Source: AC 240V, 60Hz for adapter
 Test Mode: Mode 2 Polarization: Vertical
 Note: Adapter 2

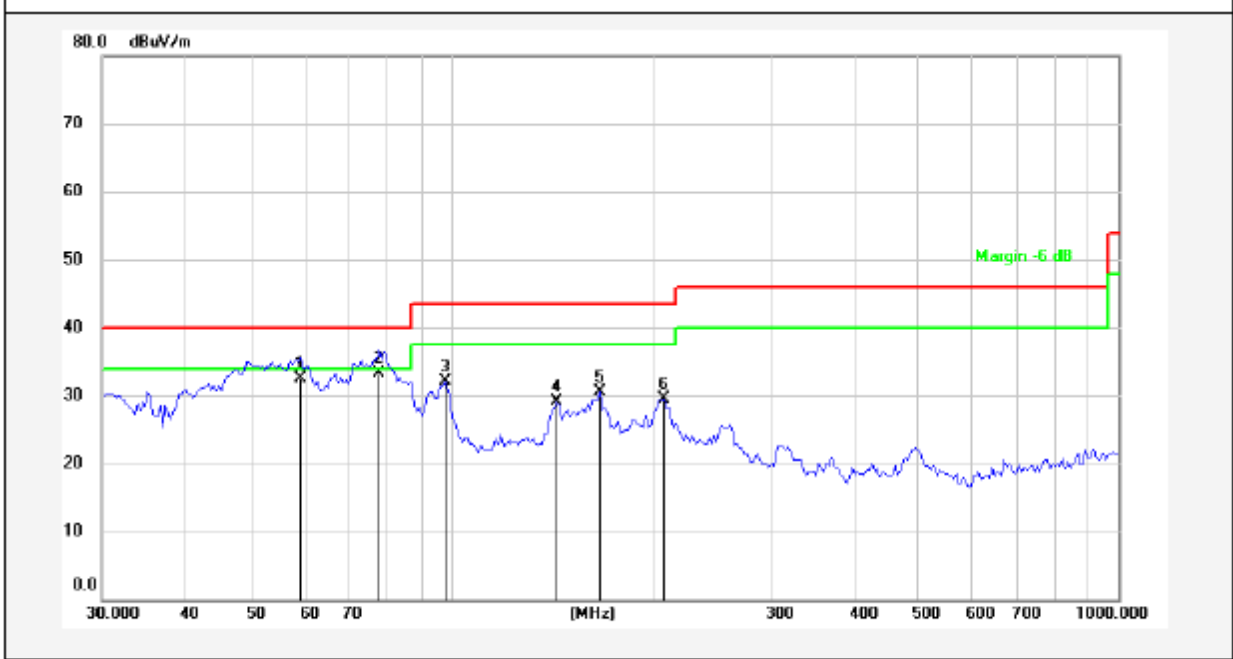

No.	Freq. (MHz)	Reading (dBuV)	Factor (dB/m)	Result (dBuV/m)	Limit (dBuV/m)	Over Limit (dB)	Detector	Height (cm)	degree (deg)	Remark
1	59.4405	47.74	-15.20	32.54	40.00	-7.46	QP	300	0	
2	78.0020	52.76	-19.51	33.25	40.00	-6.75	QP	300	74	
3	97.9699	46.82	-14.64	32.18	43.50	-11.32	QP	300	152	
4	144.0819	48.30	-19.15	29.15	43.50	-14.35	QP	300	254	
5	167.2368	48.69	-18.26	30.43	43.50	-13.07	QP	300	306	
6	208.2148	45.69	-16.23	29.46	43.50	-14.04	QP	300	360	

Test Results (1GHz-25GHz)

Test Mode: CH00					Test channel: Lowest			
Peak Value								
Frequency (MHz)	Read Level (dBuV)	Antenna Factor (dB/m)	Cable Loss (dB)	Preamp Factor (dB)	Level (dBuV/m)	Limit (dBuV/m)	Over Limit (dB)	Pol.
4804.00	38.81	34.04	6.58	34.09	45.34	74.00	-28.66	V
7206.00	32.83	37.11	7.73	34.50	43.17	74.00	-30.83	V
9608.00	32.36	39.31	9.23	34.79	46.11	74.00	-27.89	V
12010.00	*					74.00		V
14412.00	*					74.00		V
4804.00	43.40	34.04	6.58	34.09	49.93	74.00	-24.07	H
7206.00	34.71	37.11	7.73	34.50	45.05	74.00	-28.95	H
9608.00	31.92	39.31	9.23	34.79	45.67	74.00	-28.33	H
12010.00	*					74.00		H
14412.00	*					74.00		H
Average Value								
Frequency (MHz)	Read Level (dBuV)	Antenna Factor (dB/m)	Cable Loss (dB)	Preamp Factor (dB)	Level (dBuV/m)	Limit (dBuV/m)	Over Limit (dB)	Pol.
4804.00	27.34	34.04	6.58	34.09	33.87	54.00	-20.13	V
7206.00	21.34	37.11	7.73	34.50	31.68	54.00	-22.32	V
9608.00	20.33	39.31	9.23	34.79	34.08	54.00	-19.92	V
12010.00	*					54.00		V
14412.00	*					54.00		V
4804.00	31.73	34.04	6.58	34.09	38.26	54.00	-15.74	H
7206.00	23.62	37.11	7.73	34.50	33.96	54.00	-20.04	H
9608.00	20.18	39.31	9.23	34.79	33.93	54.00	-20.07	H
12010.00	*					54.00		H
14412.00	*					54.00		H

Test Results (1GHz-25GHz)

Test Mode: CH19					Test channel: Middle			
Peak Value								
Frequency (MHz)	Read Level (dBuV)	Antenna Factor (dB/m)	Cable Loss (dB)	Preamp Factor (dB)	Level (dBuV/m)	Limit (dBuV/m)	Over Limit (dB)	Pol.
4880.00	37.72	34.38	6.69	34.09	44.70	74.00	-29.30	V
7320.00	32.11	37.22	7.78	34.53	42.58	74.00	-31.42	V
9760.00	31.71	39.46	9.35	34.80	45.72	74.00	-28.28	V
12200.00	*					74.00		V
14640.00	*					74.00		V
4880.00	42.09	34.38	6.69	34.09	49.07	74.00	-24.93	H
7320.00	33.90	37.22	7.78	34.53	44.37	74.00	-29.63	H
9760.00	31.18	39.46	9.35	34.80	45.19	74.00	-28.81	H
12200.00	*					74.00		H
14640.00	*					74.00		H
Average Value								
Frequency (MHz)	Read Level (dBuV)	Antenna Factor (dB/m)	Cable Loss (dB)	Preamp Factor (dB)	Level (dBuV/m)	Limit (dBuV/m)	Over Limit (dB)	Pol.
4880.00	26.47	34.38	6.69	34.09	33.45	54.00	-20.55	V
7320.00	20.76	37.22	7.78	34.53	31.23	54.00	-22.77	V
9760.00	19.81	39.46	9.35	34.80	33.82	54.00	-20.18	V
12200.00	*					54.00		V
14640.00	*					54.00		V
4880.00	30.75	34.38	6.69	34.09	37.73	54.00	-16.27	H
7320.00	22.96	37.22	7.78	34.53	33.43	54.00	-20.57	H
9760.00	19.57	39.46	9.35	34.80	33.58	54.00	-20.42	H
12200.00	*					54.00		H
14640.00	*					54.00		H

Test Results (1GHz-25GHz)

Test Mode: CH39					Test channel: Highest			
Peak Value								
Frequency (MHz)	Read Level (dBuV)	Antenna Factor (dB/m)	Cable Loss (dB)	Preamp Factor (dB)	Level (dBuV/m)	Limit (dBuV/m)	Over Limit (dB)	Pol.
4960.00	36.89	34.72	6.79	34.09	44.31	74.00	-29.69	V
7440.00	31.55	37.34	7.82	34.57	42.14	74.00	-31.86	V
9920.00	31.22	39.62	9.46	34.81	45.49	74.00	-28.51	V
12400.00	*					74.00		V
14880.00	*					74.00		V
4960.00	41.09	34.72	6.79	34.09	48.51	74.00	-25.49	H
7440.00	33.27	37.34	7.82	34.57	43.86	74.00	-30.14	H
9920.00	30.61	39.62	9.46	34.81	44.88	74.00	-29.12	H
12400.00	*					74.00		H
14880.00	*					74.00		H
Average Value								
Frequency (MHz)	Read Level (dBuV)	Antenna Factor (dB/m)	Cable Loss (dB)	Preamp Factor (dB)	Level (dBuV/m)	Limit (dBuV/m)	Over Limit (dB)	Pol.
4960.00	25.86	34.72	6.79	34.09	33.28	54.00	-20.72	V
7440.00	20.34	37.34	7.82	34.57	30.93	54.00	-23.07	V
9920.00	19.44	39.62	9.46	34.81	33.71	54.00	-20.29	V
12400.00	*					54.00		V
14880.00	*					54.00		V
4960.00	30.05	34.72	6.79	34.09	37.47	54.00	-16.53	H
7440.00	22.49	37.34	7.82	34.57	33.08	54.00	-20.92	H
9920.00	19.14	39.62	9.46	34.81	33.41	54.00	-20.59	H
12400.00	*					54.00		H
14880.00	*					54.00		H

Remark:

1. Level =Receiver Read level + Antenna Factor + Cable Loss – Preamplifier Factor
2. “*” means the test results were attenuated more than 20dB below the permissible limits, so the results don't record in the report.

Radiated Band Edge:



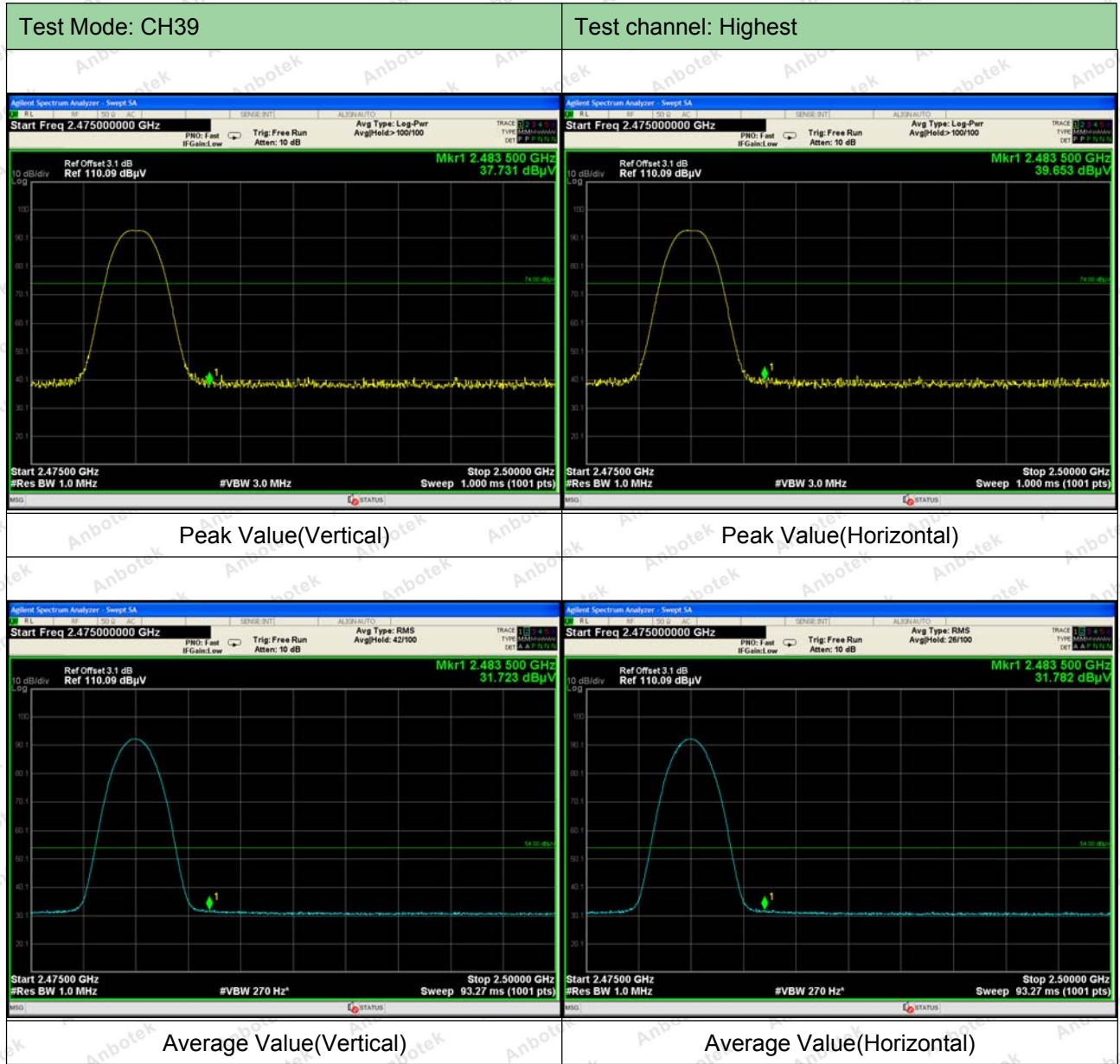

Remark:

1. Level = Receiver Read level + Antenna Factor + Cable Loss – Preamplifier Factor

5. Maximum Peak Output Power Test

5.1. Test Standard and Limit

Test Standard	FCC Part15 C Section 15.247 (b)(3)
Test Limit	30dBm

5.2. Test Setup

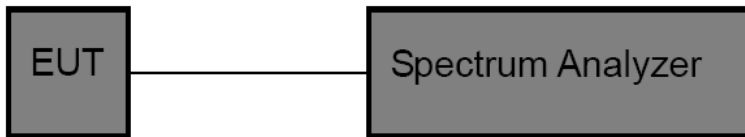

5.3. Test Procedure

This procedure shall be used when the measurement instrument has available a resolution bandwidth that is greater than the DTS bandwidth.

1. Set the RBW \geq DTS bandwidth.
2. Set the VBW $\geq 3 \times$ RBW.
3. Set the span $\geq 3 \times$ RBW.
4. Detector = peak.
5. Sweep time = auto couple.
6. Trace mode = max hold.
7. Allow trace to fully stabilize.
8. Use peak marker function to determine the peak amplitude level.

5.4. Test Data

Test Item	: Max. peak output power	Test Mode	: CH Low ~ CH High
Test Voltage	: AC 120V, 60Hz for adapter	Temperature	: 24.1°C
Test Result	: PASS	Humidity	: 53%RH

Channel Frequency (MHz)	Peak Power output (dBm)	Limit (dBm)	Results
2402	-2.303	30	PASS
2440	-2.149	30	PASS
2480	-0.557	30	PASS

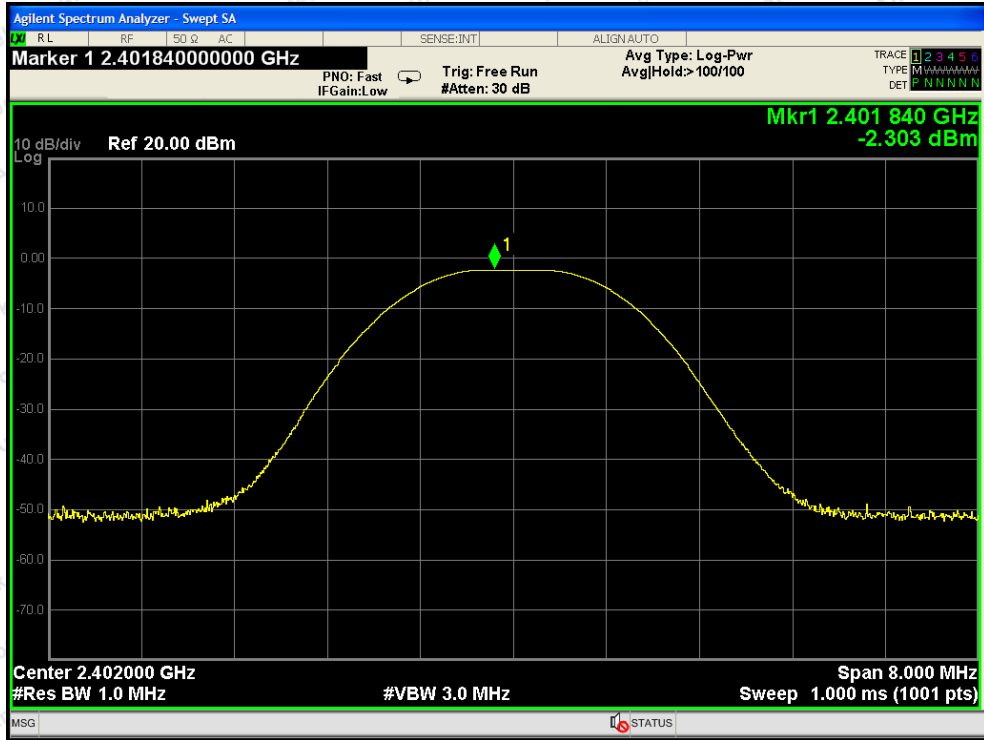

CH: Low

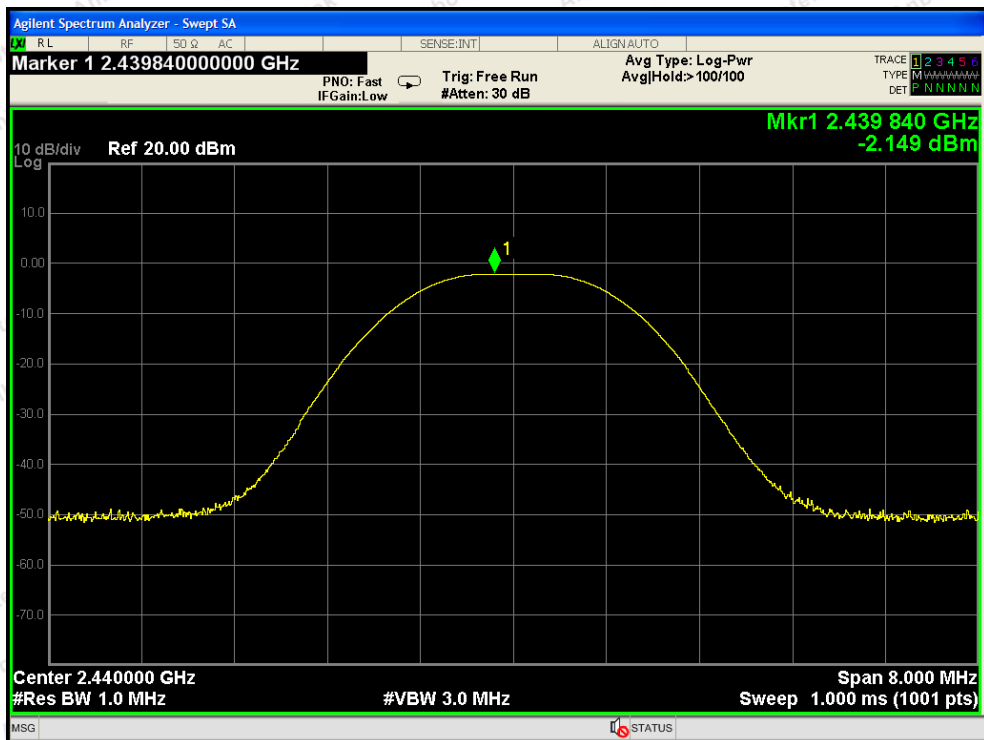

CH: Middle

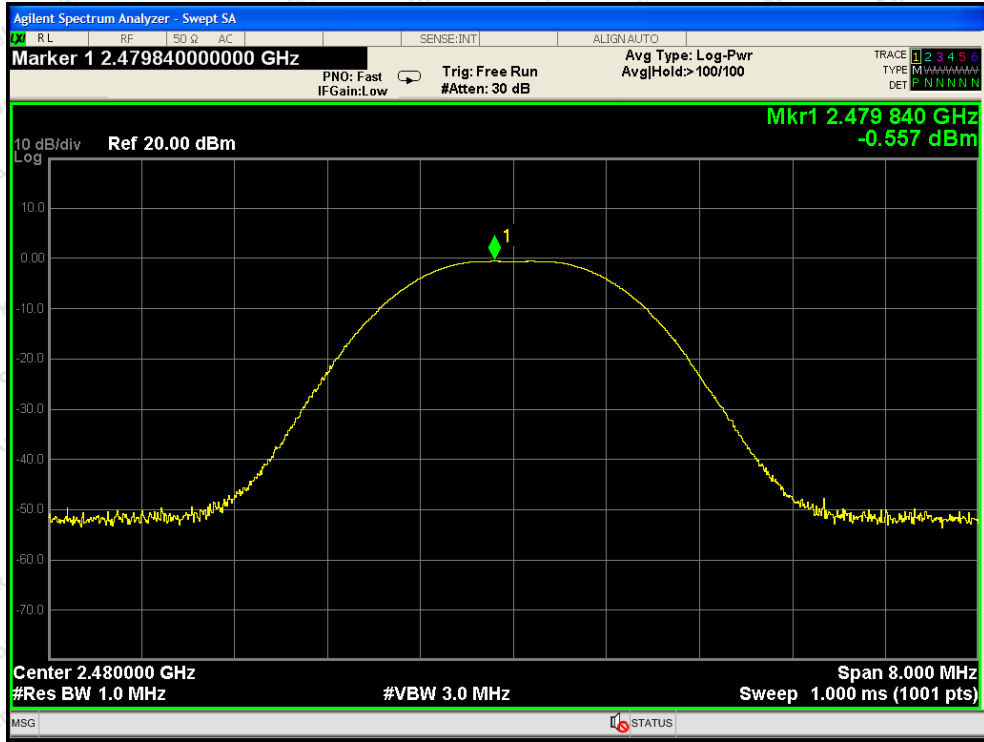

CH: High

6. 6DB Occupy Bandwidth Test

6.1. Test Standard and Limit

Test Standard	FCC Part15 C Section 15.247 (a)(2)
Test Limit	>500kHz

6.2. Test Setup

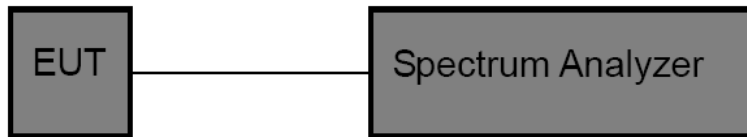

6.3. Test Procedure

1. Place the EUT on the table and set it in the transmitting mode.
2. Remove the antenna from the EUT and then connect a low loss RF cable from the antenna port to the spectrum analyzer.
3. Set the spectrum analyzer as:
RBW = 100kHz, VBW \geq 3*RBW =300kHz,
Detector= Peak
Trace mode= Max hold.
Sweep- auto couple.
4. Mark the peak frequency and -6dB (upper and lower) frequency.
5. Repeat until all the rest channels are investigated.

6.4. Test Data

Test Item	: 6dB Bandwidth	Test Mode	: CH Low ~ CH High
Test Voltage	: AC 120V, 60Hz for adapter	Temperature	: 24.1°C
Test Result	: PASS	Humidity	: 53%RH

Channel	Frequency(MHz)	Bandwidth (kHz)	Limit (kHz)	Results
Low	2402	698.8	>500	PASS
Middle	2440	695.9		PASS
High	2480	698.5		PASS

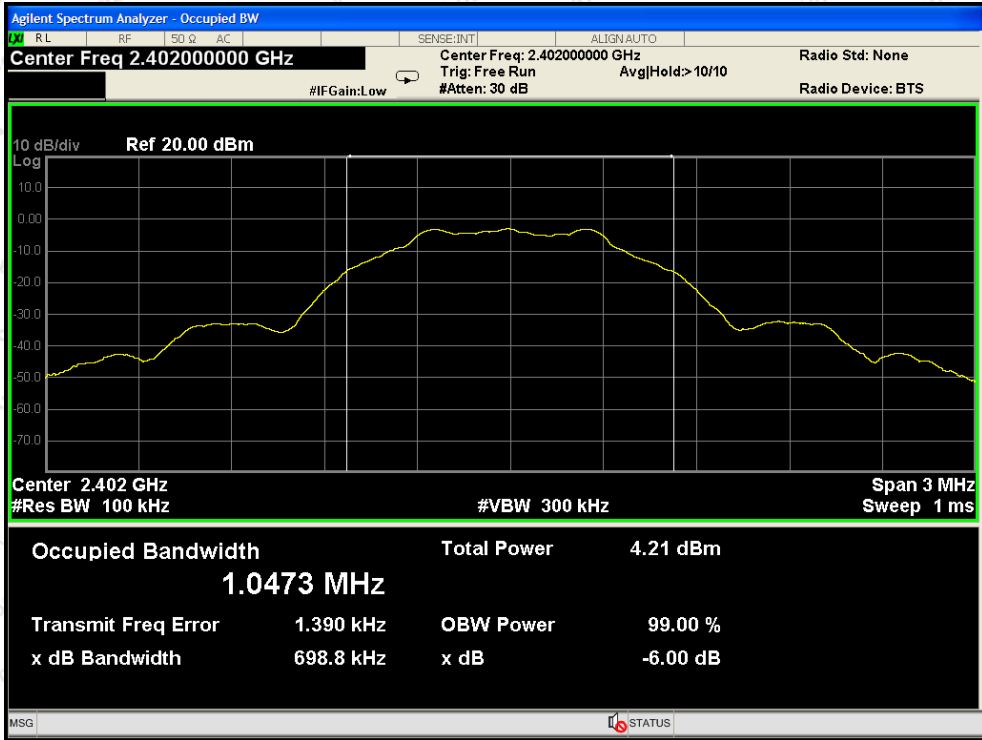

CH: Low

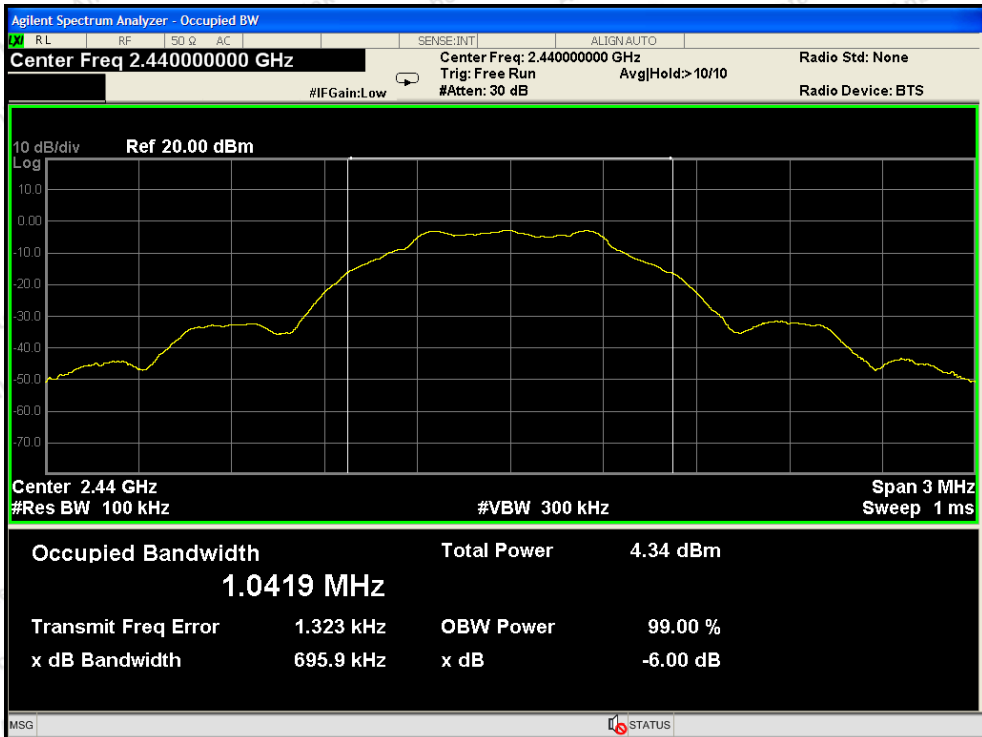

CH: Middle

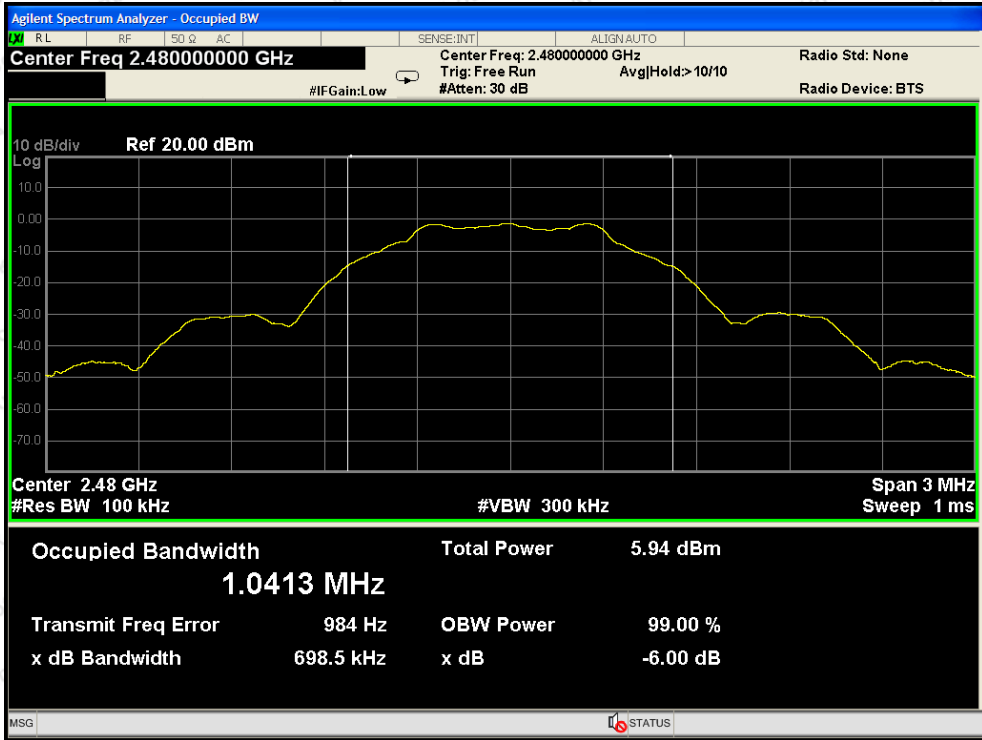

CH: High

7. Power Spectral Density Test

7.1. Test Standard and Limit

Test Standard	FCC Part15 C Section 15.247 (e)
Test Limit	8dBm

7.2. Test Setup

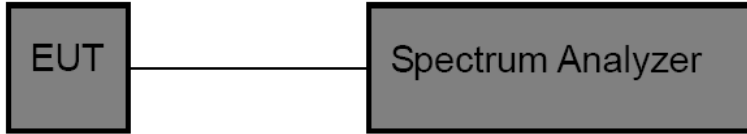

7.3. Test Procedure

1. Place the EUT on the table and set it in transmitting mode. Remove the antenna from the EUT and then connect a low loss RF cable from the antenna port to the spectrum analyzer.
2. Set the spectrum analyzer as RBW = 3kHz, VBW = 10kHz, Span = 1.5xDTS BW
3. Record the max. reading.
4. Repeat the above procedure until the measurements for all frequencies are completed.

7.4. Test Data

Test Item	: Power Spectral Density	Test Mode	: CH Low ~ CH High
Test Voltage	: AC 120V, 60Hz for adapter	Temperature	: 24.1°C
Test Result	: PASS	Humidity	: 53%RH

Channel	Frequency (MHz)	PSD (dBm/3KHz)	Limit (dBm/3KHz)	Results
Low	2402	-17.217	8.00	PASS
Middle	2440	-17.042	8.00	PASS
High	2480	-15.472	8.00	PASS

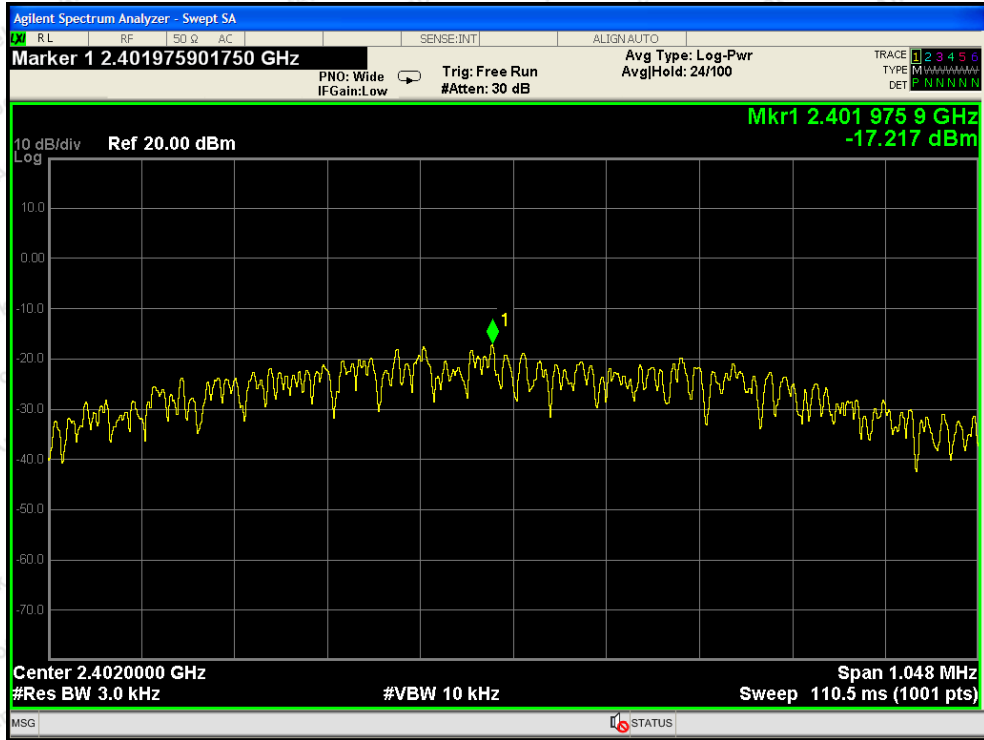

CH: Low

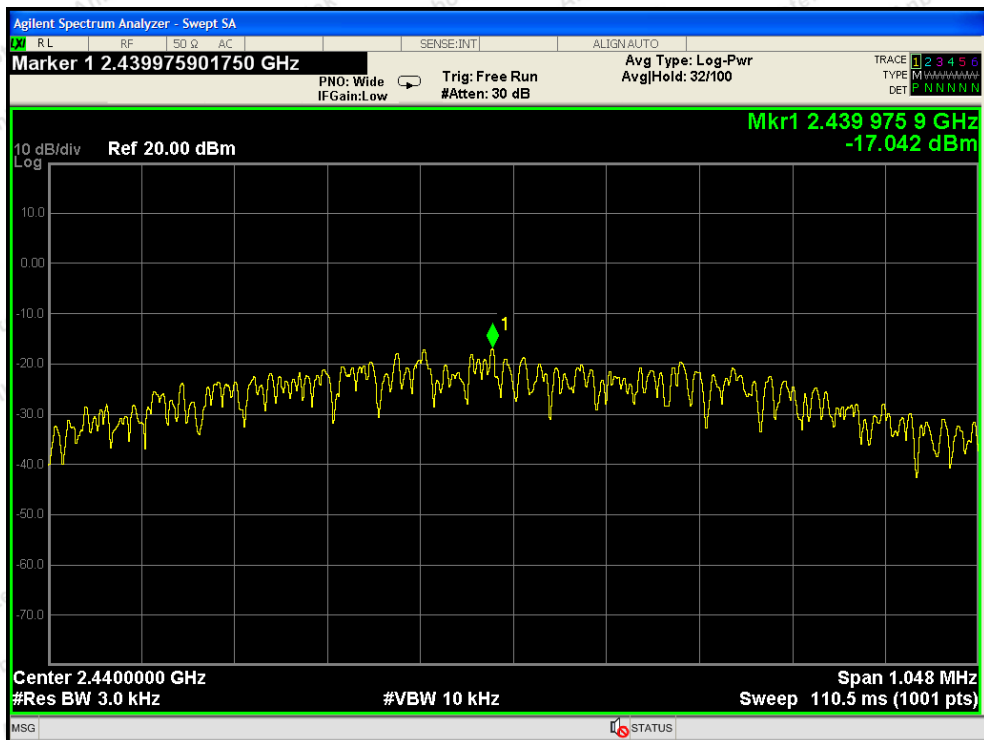

CH: Middle

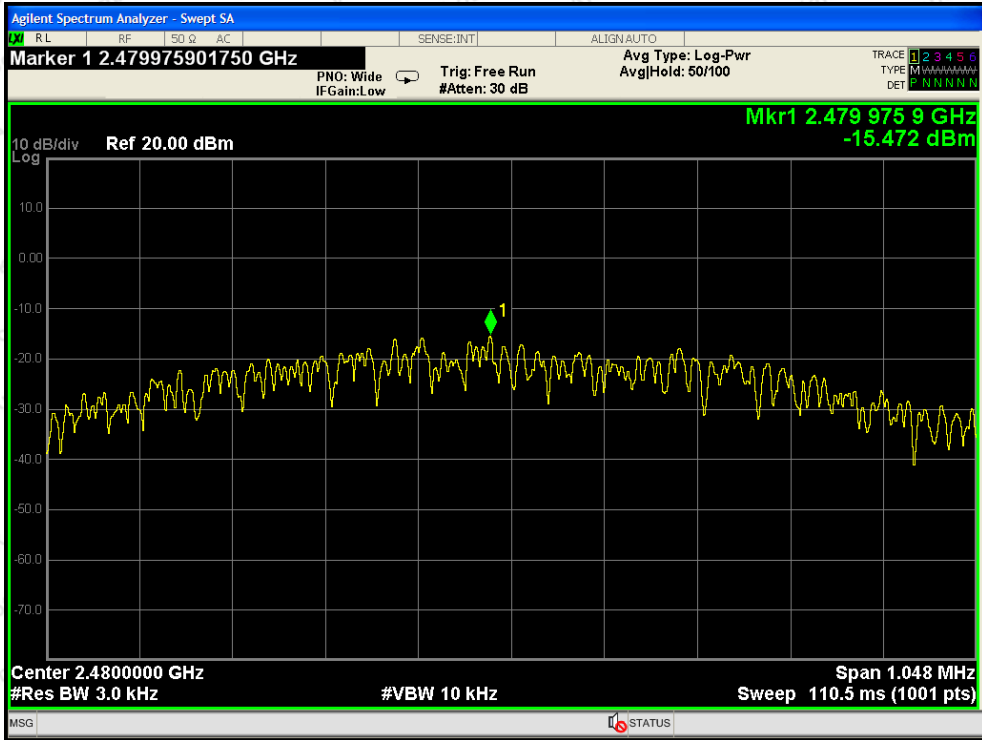

CH: High

8. 100kHz Bandwidth of Frequency Band Edge Requirement

8.1. Test Standard and Limit

Test Standard	FCC Part15 C Section 15.247 (d)
Test Limit	in any 100 kHz bandwidth outside the frequency bands in which the spread spectrum intentional radiator in operating, the radio frequency power that is produced by the intentional radiator shall be at least 20dB below that in the 100kHz bandwidth within the band that contains the highest level of the desired power, In addition, radiated emissions which fall in the restricted bands, as defined in §15.205(a), must also comply with the radiated emission

8.2. Test Setup

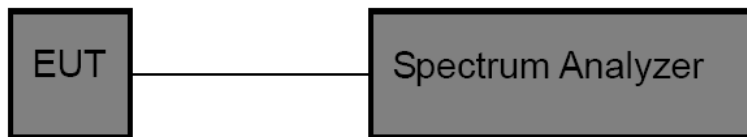

8.3. Test Procedure

Using the following spectrum analyzer setting:

1. Set the RBW = 100KHz.
2. Set the VBW = 300KHz.
3. Sweep time = auto couple.
4. Detector function = peak.
5. Trace mode = max hold.
6. Allow trace to fully stabilize.

8.4. Test Data

Test Item	: Band edge	Test Mode	: CH Low ~ CH High
Test Voltage	: AC 120V, 60Hz for adapter	Temperature	: 24.1°C
Test Result	: PASS	Humidity	: 53%RH

Frequency Band (MHz)	Delta Peak to Band Emission (dBc)	Limit (dBc)	Results
2400	55.511	>20	PASS
2483.5	60.568	>20	PASS

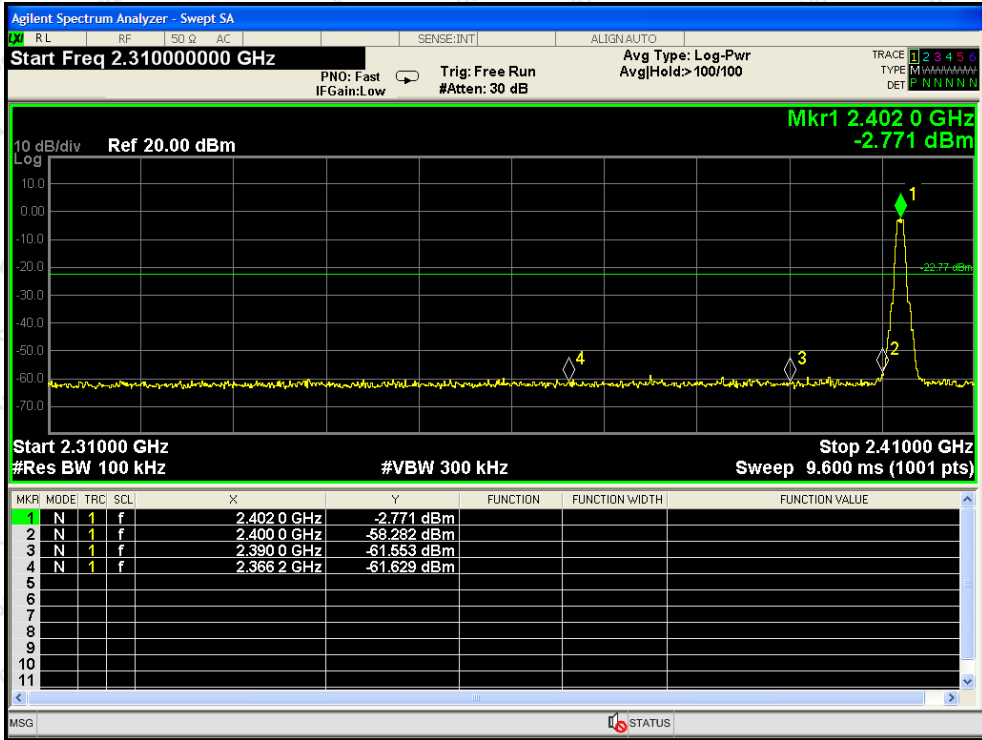

CH: Low

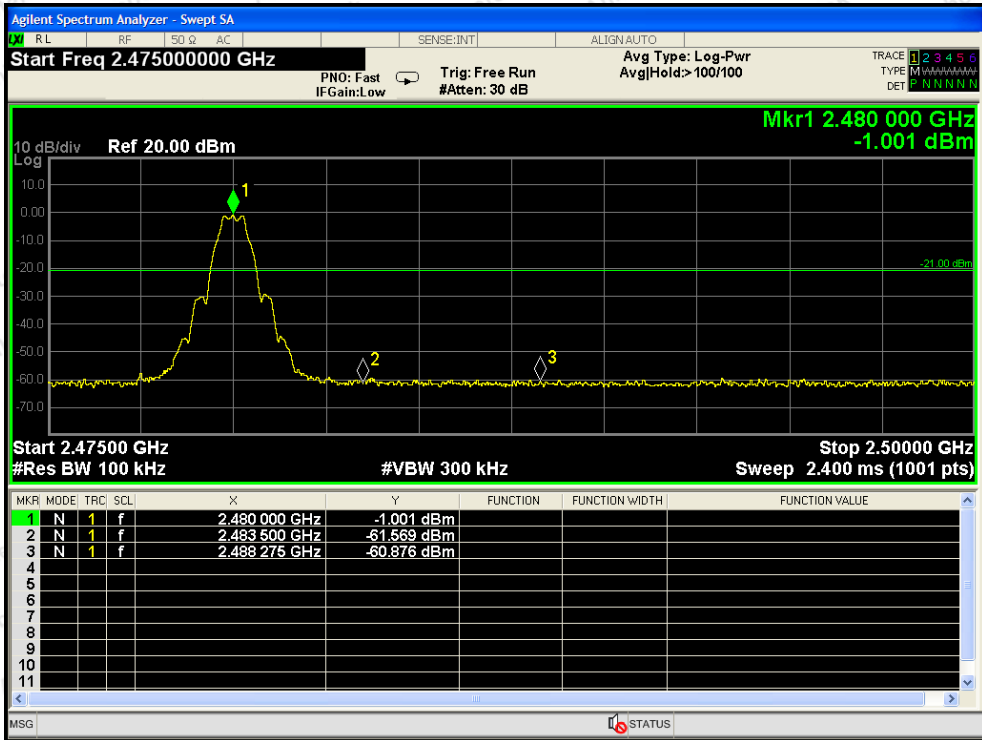

CH: High

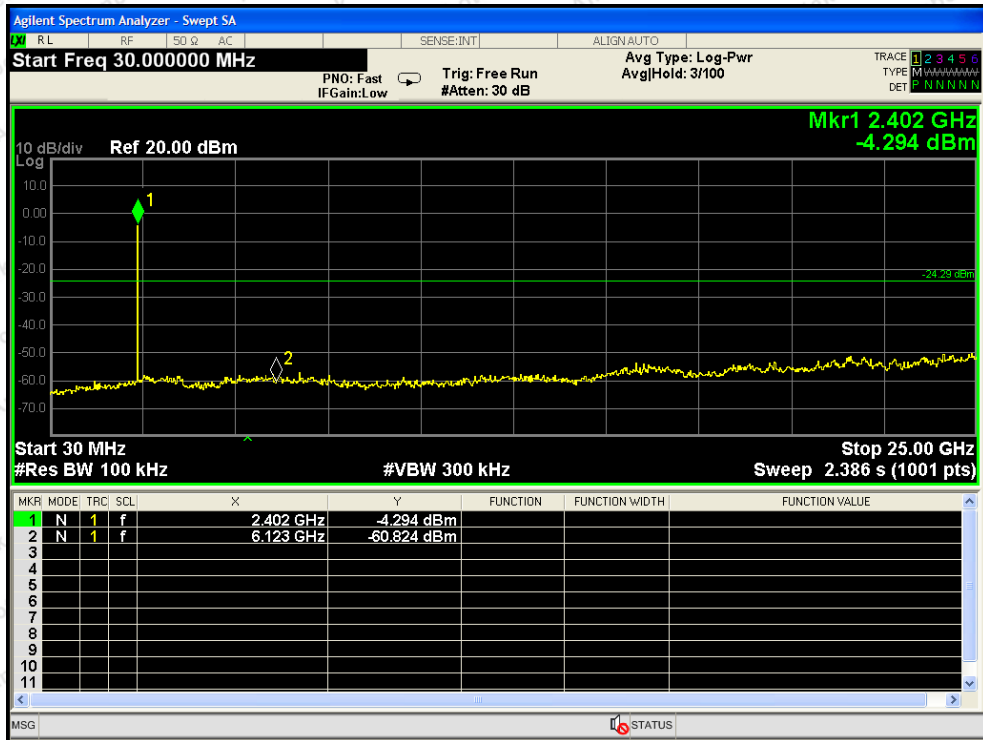

CH: Low

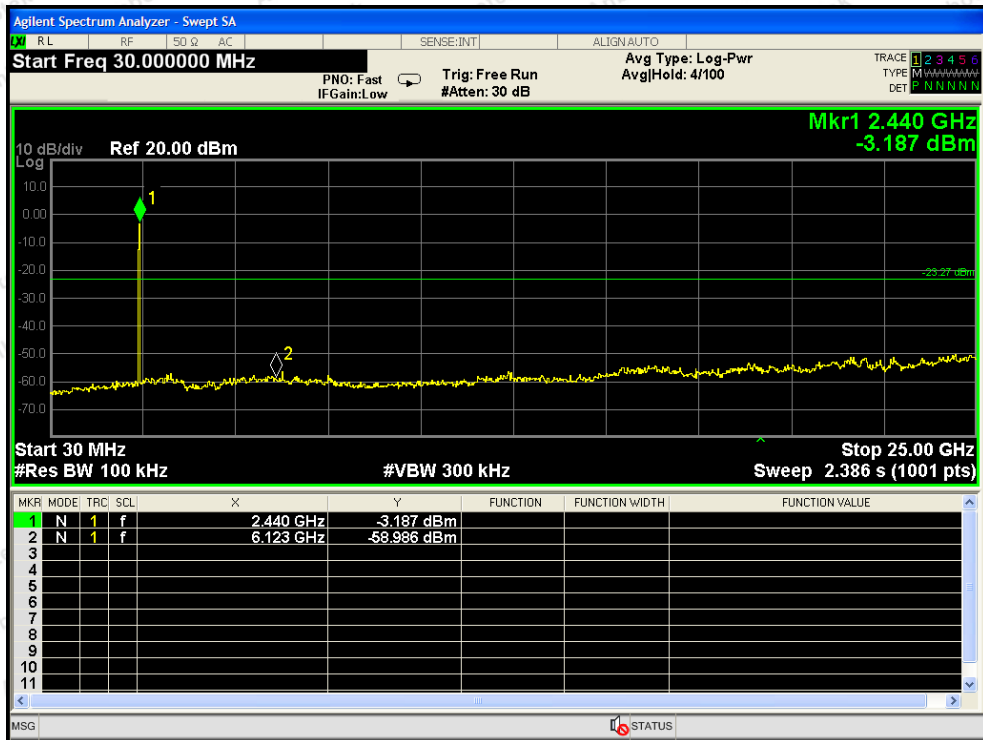

CH: Middle

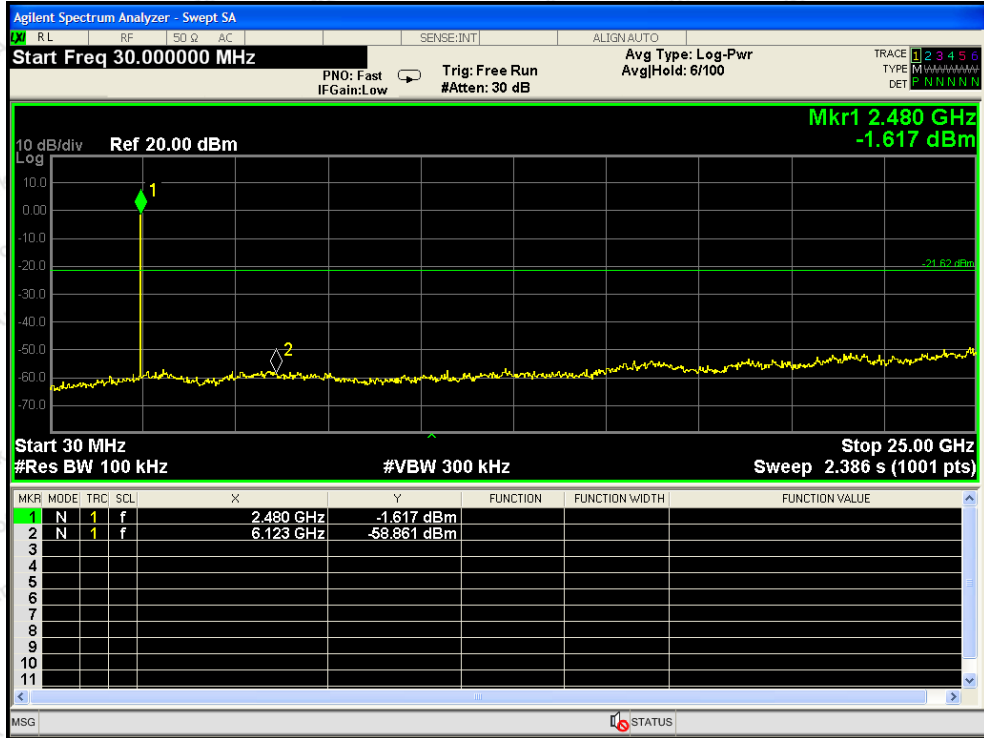

CH: High

9. Antenna Requirement

9.1. Test Standard and Requirement

Test Standard	FCC Part15 Section 15.203 /247(c)
Requirement	<p>1) 15.203 requirement: An intentional radiator shall be designed to ensure that no antenna other than that furnished by the responsible party shall be used with the device. The use of a permanently attached antenna or of an antenna that uses a unique coupling to the intentional radiator, the manufacturer may design the unit so that a broken antenna can be replaced by the user, but the use of a standard antenna jack or electrical connector is prohibited.</p> <p>2) 15.247(c) (1)(i) requirement: Systems operating in the 2400-2483.5 MHz band that is used exclusively for fixed. Point-to-point operations may employ transmitting antennas with directional gain greater than 6dBi provided the maximum conducted output power of the intentional radiator is reduced by 1 dB for every 3 dB that the directional gain of the antenna</p>

9.2. Antenna Connected Construction

The antenna is a PCB Antenna which permanently attached, and the best case gain of the antenna is 0.5 dBi. It complies with the standard requirement.

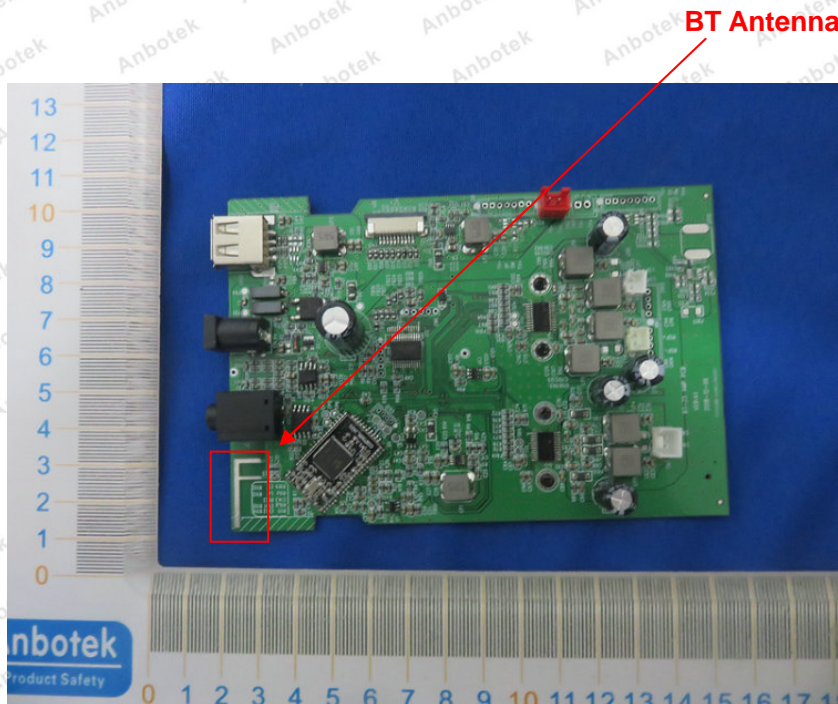

APPENDIX I -- TEST SETUP PHOTOGRAPH

Please refer to the test report SZAWW190212001-01.



APPENDIX II -- EXTERNAL PHOTOGRAPH

Please refer to the test report SZAWW190212001-01.

APPENDIX III -- INTERNAL PHOTOGRAPH

Please refer to the test report SZAWW190212001-01.

----- End of Report -----

Shenzhen Anbotek Compliance Laboratory Limited

Code:AB-RF-05-a

Address: 1/F, Building D, Sogood Science and Technology Park, Sanwei Community,
Hangcheng Street, Bao'an District, Shenzhen, Guangdong, China.

Tel:(86)755-26066440 Fax:(86)755-26014772 Email:service@anbotek.com



Hotline
400-003-0500

www.anbotek.com