

## MAKING THE ELECTRIC CONNECTIONS

1. Connect the black (hot) wire from the ceiling to the black wire marked “AC in L” from the receiver.
2. Connect the white (neutral) from the ceiling to the white wire marked “AC in N” from the receiver.

Wall transmitter to wall outlet box electrical connections: (Fig. 01)

1. Connect the white wire from the transmitter to the white (neutral) wire from the wall outlet box.
2. Connect the red wire from the transmitter to the black wire from the wall outlet box that feeds up to the fan.
3. Connect the black wire marked “LINE IN” from the transmitter to the black LINE VOLTAGE wire from the outlet box that feeds back to the main fuse box.
4. Connect ground wires - Important for proper control function.

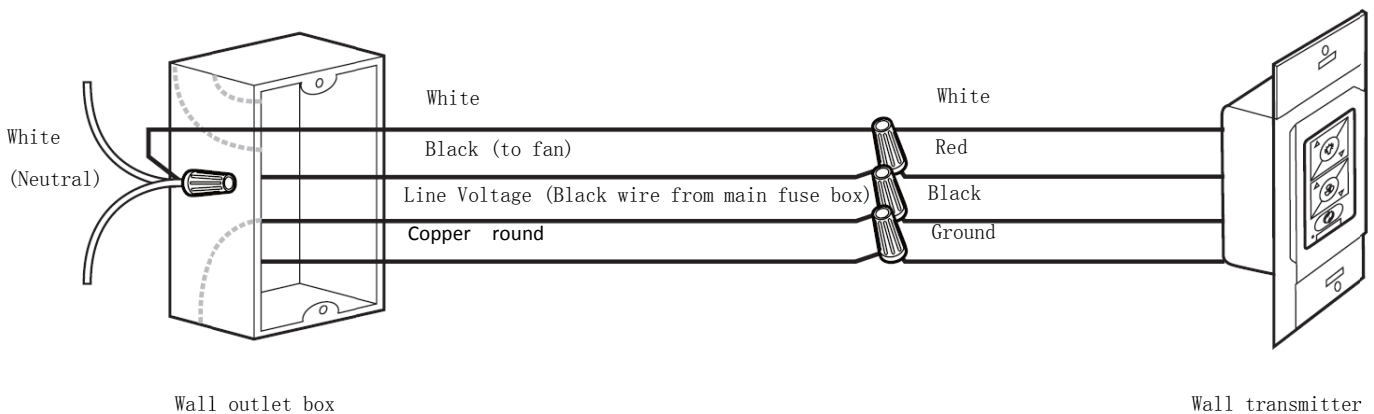

Fig.01

## INSTALLING THE WALL TRANSMITTER

**WARNING:** Remember to shut the power off at the circuit breaker or fuse box.

1. Carefully tuck the wire connections inside the junction box.
- Secure the wall transmitter with the two wall transmitter screws provided. (Fig. 02)
2. Attach the wall mounting plate over the wall switch and secure with the two wall mounting plate screws provided.
3. Fasten the wall plate to the wall mounting plate.

**NOTE:** Maximum of 4 fans can operate on a circuit through the wall transmitter. Maximum of 12 fans can operate on a circuit through an on/off switch or breaker when utilizing the app for the fan control (without the wall transmitter in the circuit).

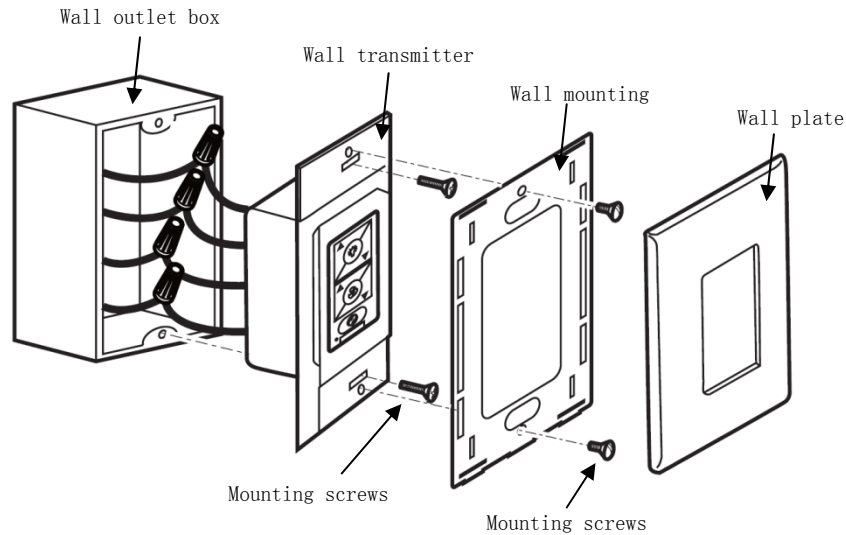

Fig.02

## WALL TRANSMITTER OPERATING INSTRUCTIONS

Your DC motor is equipped with an automatically learned type wall control. Restore power to ceiling fan and test the wall control as below for proper operation.

### Pairing the Remote Control to Your Fan

Your fan is pre-paired at the factory, NO pairing is necessary.

### Remote Control Button Definitions

These seven buttons are used to set the fan speed as follows:



Button: turns the light ON or OFF and also controls the brightness setting.

Press  to increase the desired light level.

Press  to decrease the desired light level.



Button: Controls fan direction.

Pressing and holding the button  will increase the fan speed automatically through the speed settings.

Pressing and holding the button  will decrease the fan speed automatically through the speed settings.



Button: Switch between summer mode and winter mode.

### Pairing the Remote Control to Your Fan

Your fan is pre-paired at the factory, NO pairing is necessary.

## Remote Control Button Definitions

These seven buttons are used to set the fan speed as follows:

**ON-OFF** Button: To power for emergency use. Not necessary for normal fan operation.

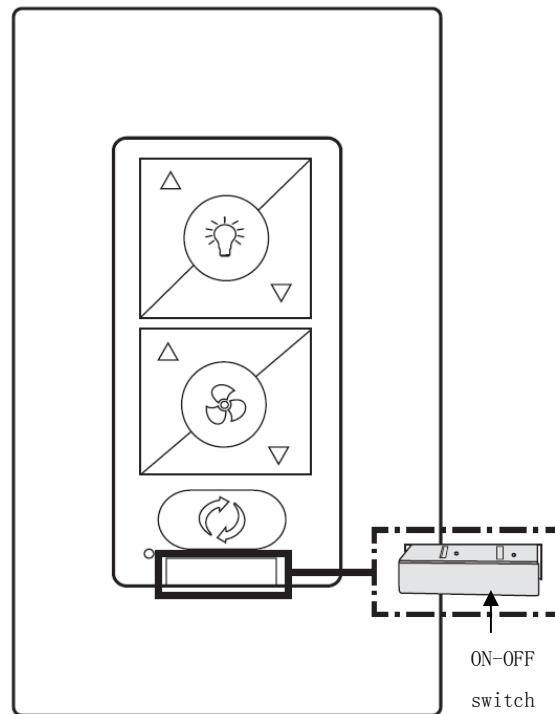

Fig.03

Any Changes expressly or modifications not approved by the party responsible for compliance could void the user's authority to operate the equipment.

This device complies with part 15 of the FCC Rules. Operation is subject to the following two conditions: (1) This device may not cause harmful interference, and (2) this device must accept any interference received, including interference that may cause undesired operation.

Note: This equipment has been tested and found to comply with the limits for a Class B digital device, pursuant to part 15 of the FCC Rules. These limits are designed to provide reasonable protection against harmful interference in a residential installation. This equipment generates, uses and can radiate radio frequency energy and, if not installed and used in accordance with the instructions, may cause harmful interference to radio communications. However, there is no guarantee that interference will not occur in a particular installation. If this equipment does cause harmful interference to radio or television reception, which can be determined by turning the equipment off and on, the user is encouraged to try to correct the interference by one or more of the following measures:

- Reorient or relocate the receiving antenna.
- Increase the separation between the equipment and receiver.
- Connect the equipment into an outlet on a circuit different from that to which the receiver is connected.
- Consult the dealer or an experienced radio/TV technician for help.