

---

## Part 1 – How to install the Wall Light

### Warnings and cautions

- (1) All parts must be used as indicated in these instructions. This product is designed for use only with the supplied parts and/or accessories designated for use by manufacturer. Substitution of parts or accessories not designated for use with this product by manufacturer could result in personal injury or property damage, and will void the warranty. Contact an authorized dealer or the manufacturer if any parts are damaged or missing.
- (2) Make sure to cut off power before installation
- (3) If there is any damage to the cord, Please cut off the power and stop using it immediately
- (4) Suitable for general outdoor use.
- (5) Do not submerge in water.
- (6) This product is not a toy and is not designed for use by children.
- (7) For safety reasons and under the terms of the warranty, the enclosed device should not be opened
- (8) In case of explosion. Please keep the light away from fire and high temperature.

#### FCC Radiation Exposure Statement:

This equipment complies with FCC radiation exposure limits set forth for an uncontrolled environment . This transmitter must not be co-located or operating in conjunction with any other antenna or transmitter. Any Changes expressly or modifications not approved by the party responsible for compliance could void the user's authority to operate the equipment. This device complies with part 15 of the FCC Rules.

Operation is subject to the following two conditions:

- (1) This device may not cause harmful interference,
- and (2) this device must accept any interference received, including interference that may cause undesired operation.

### Specification

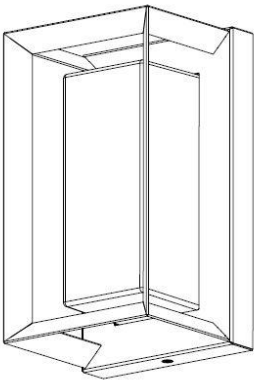
SKU	WSW R1	
Input Voltage	120V	
Input Wattage	12-watt	
Output Wattage	RGB, 4-watt of each color. W, 12-watt	
Color	RGBW, W=2700K	
Light output	810 Lumen at 2700K, 80+CRI	
Wireless type	BLE 5.0 (2.4G)	
IP rating	Wet Location	
Use temperature	-20~40°C	
Warranty	2-year	

**Components**

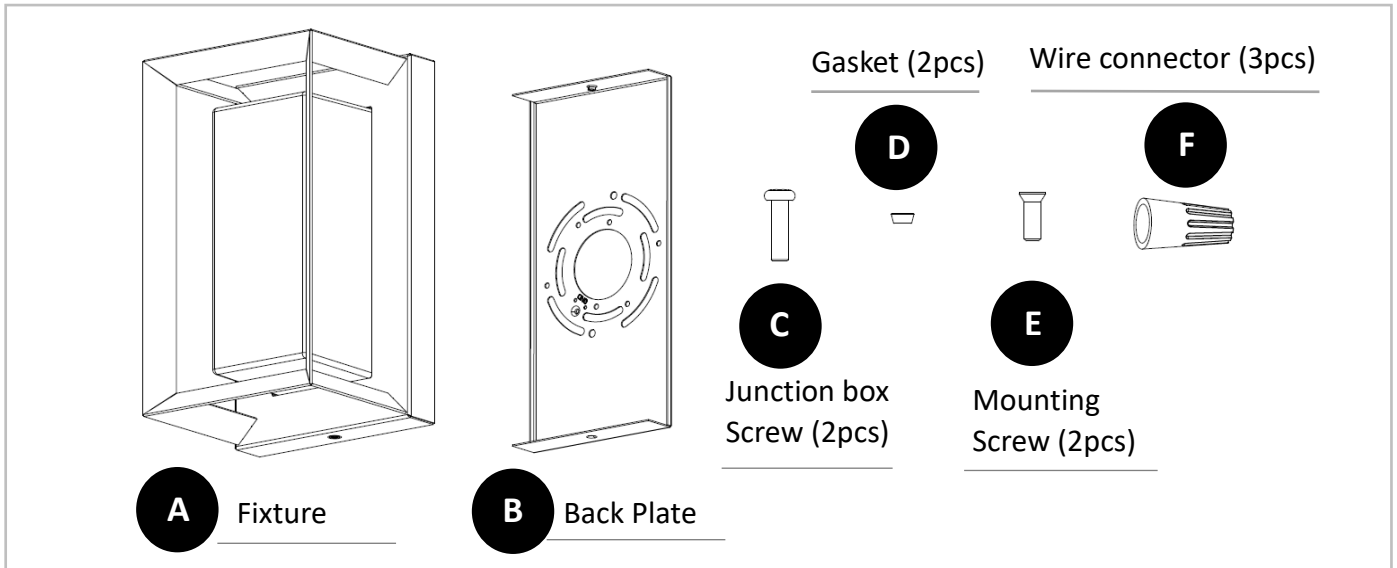

**Installation**

**Step 1, Mount the fixture**

- (1) Secure the back plate (B) to the junction box with junction box screw (C).
- (2) Do the wiring connection with wire connector (F) and following the indication of fig.1 and fig.2.
- (3) Put the gasket(D) over the mounting screw(E), and fasten the lamp(A) to back plate via mounting screw.
- (4) To prevent moisture/water from entering the outlet box and causing a short, use clear caulking (i.e. outdoor silicone sealant) to outline the outside of lamp canopy where it meets the wall. Leave a space at the bottom to allow moisture to escape (Fig.4).

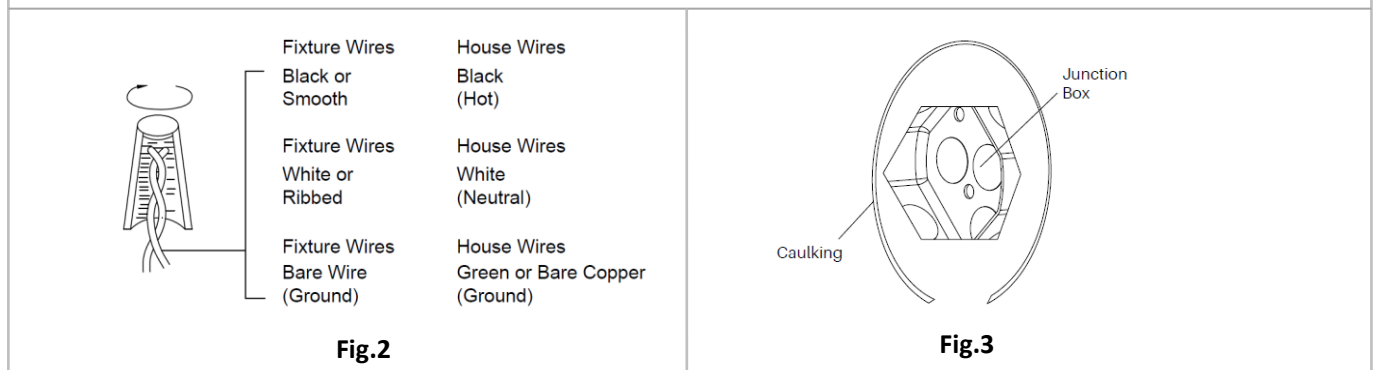
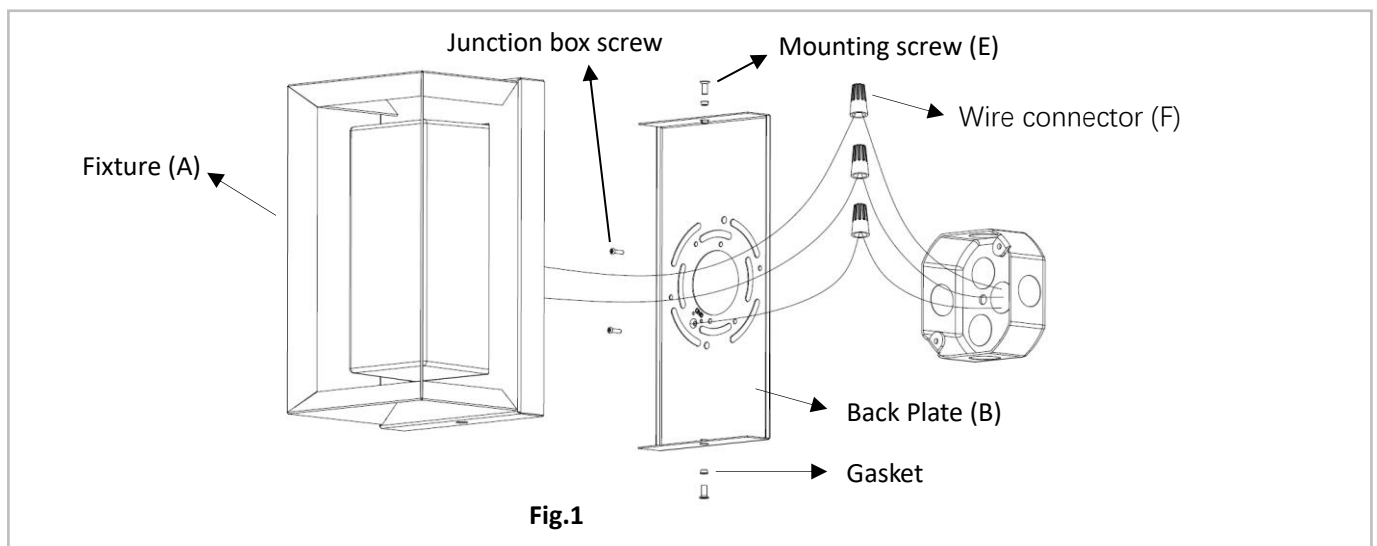

# User Manual

## Smart Wall Light

WSW R

---

### Part 2 – How to Pair the light to smart life app?

Important notes before starting -

- (1) Ihomehome bridge (Sold separately) is required working with Alexa, Google assistant or do the non-local control. Bridge is not required using as a Bluetooth light.
- (2) Please make sure the WiFi signal strength is strong enough for the wall light.
- (3) We strongly recommend that the distance between the wall light and the bridge is kept within 65ft/20m, that the distance between the bridge and your WiFi router is kept within 65ft/20m.
- (4) Before starting the paring, please make sure to turn on the Bluetooth and WiFi on your phone.
- (5) The smart light only support 2.4GHz WiFi network, not 5.0GHz. Please make sure the working network is 2.4G, and your phone is connected to it. If your WiFi router supports both 2.4G and 5.0GHz, please separate the two frequency bands in the router settings, and select the 2.4GHz for connection.

Step 1, Smart Life app installation.

Please choose either way below to download and install the app.

- (1) As per your phone system, choose the QR code to scan.



iOS



Android

- (2) Search keyword 'Smart Life' in Apple Store or Google Play.

Step 2, Create an account on Smart life and login

Note: Please keep your account and password in mind for Alexa or Google Assistant App pairing later.

Step3, Add the light to smart life App

- (1) Find the device of ihomehome bridge, see the manual of ihomehome bridge, Tap 'the bridge', click the button of 'Add new device'.
- (2) Power on the light with your own switch, if you find the light breathe in white light, Tap '+' button on top right corner to add devices. then find the light device and click 'add'. If you find the light did not breathe when turn on the power. Reset the device that repeatedly turn on-off-on-off-on-off-on switch (3 times), the light breathe that mean it's ready for the connection, Tap '+' button on top right corner to add device. To find the light device and click 'Add'.
- (3) Choose your WiFi network, enter your password, and tap the 'Next' button. Then give a name to the light and tap the 'Done' button.

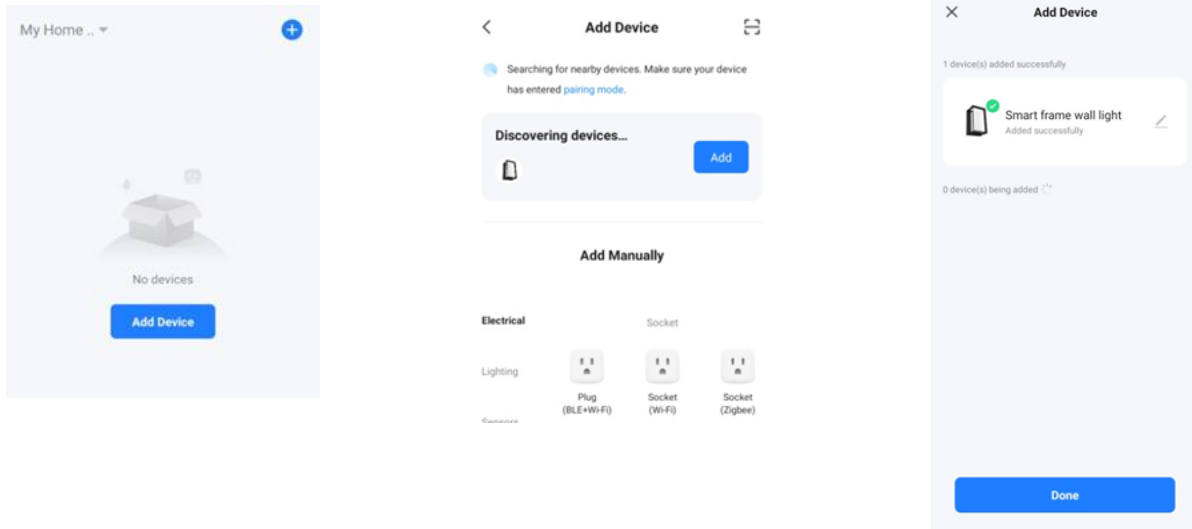

#### Step 4, Give a name to the light

- (1) A simple name is recommended for easier voice recognition with Alexa or Google Assistant.
- (2) The name given to the light will be the same for voice control on Alexa or google assistant.

#### Step 5, Control the light

The named light will be shown on the app homepage. Now you can control the light (turn on/off, change colors, adjust brightness ect) with Smart life on the setting page.

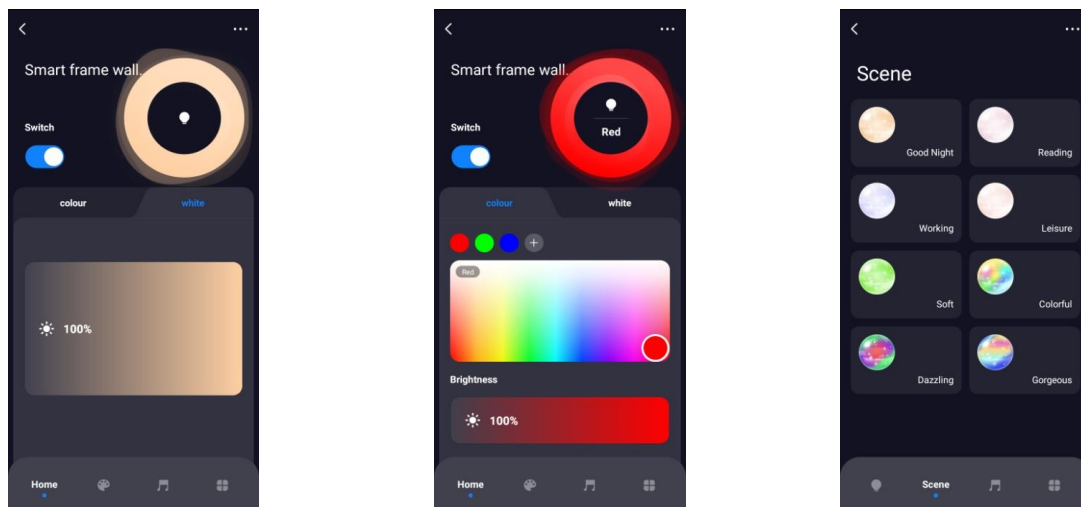

#### Step 6, How to group the wall light

Note, all the light need to be the same model and already paired to smart life APP before create a group.

- (1), Choose any wall light on the app, click the edit button on the top right corner, then click 'create group'.
- (2), Choose the wall lights you want to group from the device list and rename the group.

Now you can control the wall lights and sync with the music, the colors will be synchronized in the group.

## Part 3 – How to control the light with Amazon Alexa?

Please make sure that your Alexa app is connected to Echo, and both work well under your WiFi network.

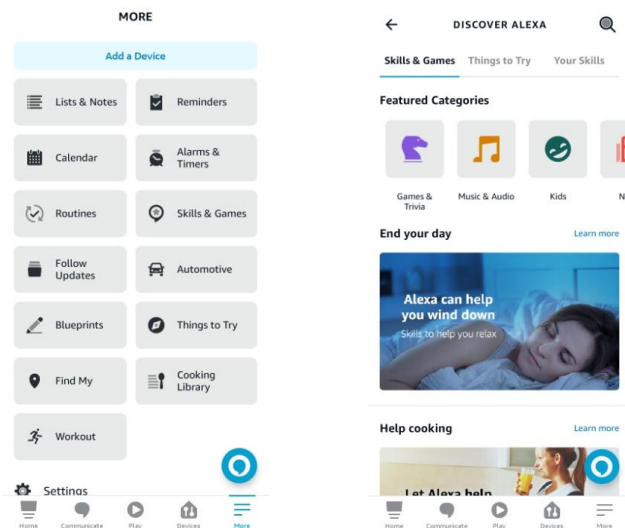

Step 1, Log in your Alexa App, tap top left corner, and tap 'Skills'.

Step 2, Type 'Smart Life', find 'Smart Life' from the search result and tap it to enable the skill.

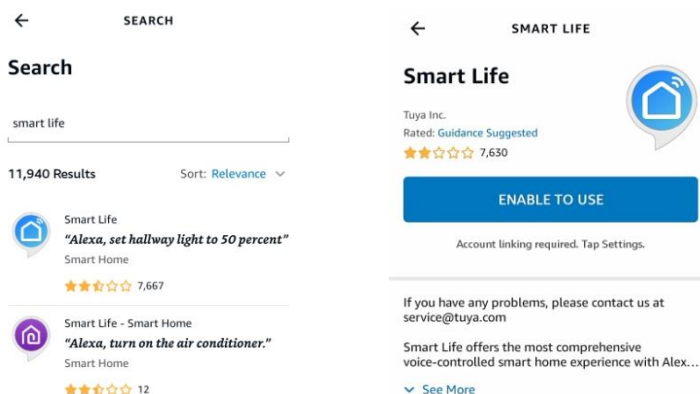

Step 3, Enter your smart life APP account and password. Tap 'Link Now', then tap 'Authorize' on the next page to bind Smart life account to Alexa.

Step 4, When your smart life account is bound to Alexa, Tap 'Discover Devices' to detect the light.

Step 5, When the named light is paired to Alexa from Smart Life, it will show on the device page (see the 'smart light' example).

Step 6, Now you can control the light with Alexa App on the setting page, To turn on or off the light, simply tap the bulb icon.

Step 7, You can also voice control the light with Alexa by giving these commands: "Alexa, Turn on 'Device name'", "Alexa, set 'device name' to 'color'", "Alexa, set 'device name' to 'number' ". Device name is the one you give to the light. The light is named 'Smart Light' in this user guide. For example, "Alexa, turn on 'smart life' ", "Alexa, Set 'smart light' to 'blue'" etc.

Note: To control the light with Google Assistant, please continue to read Part Four.

This device complies with Part 15 of the FCC Rules. Operation is subject to the following two conditions: (1) this device may not cause harmful interference, and (2) this device must accept any interference received, including interference that may cause undesired operation

NOTE: This equipment has been tested and found to comply with the limits for a Class B digital device, pursuant to Part 15 of the FCC Rules. These limits are designed to provide reasonable protection against harmful interference in a residential installation. This equipment generates, uses and can radiate radio frequency energy and, if not installed and used in accordance with the instructions, may cause harmful interference to radio communications. However, there is no guarantee that interference will not occur in a particular installation.

If this equipment does cause harmful interference to radio or television reception, which can be determined by turning the equipment off and on, the user is encouraged to try to correct the interference by one or more of the following measures:

- Reorient or relocate the receiving antenna.
- Increase the separation between the equipment and receiver.
- Connect the equipment into an outlet on a circuit different from that to which the receiver is connected.
- Consult the dealer or an experienced radio/TV technician for help.

Warning: changes or modifications not expressly approved by the party responsible for compliance could void the user's authority to operate the equipment

#### Radiation Exposure Statement

This equipment complies with FCC radiation exposure limits set forth for an uncontrolled environment.

This equipment should be installed and operated with minimum distance 20cm between the radiator and your body.