

# GROW & STOW™ CHRISTMAS TREE



ASSEMBLY INSTRUCTIONS

## IMPORTANT SAFETY INSTRUCTIONS

When using electrical products, basic precautions should always be followed including the following:

- a) **READ AND FOLLOW ALL SAFETY INSTRUCTIONS.**
- b) Do not use seasonal products outdoors unless marked suitable for indoor and outdoor use. When products are used in outdoor applications, connect the product to a Ground Fault Circuit Interrupting (GFCI) outlet. If one is not provided, contact a qualified electrician for proper installation.
- c) This seasonal use product is not intended for permanent installation or use.
- d) Do not mount or place near gas or electric heaters, fireplace, candles or other similar sources of heat.
- e) Do not secure the wiring of the product with staples or nails, or place on sharp hooks or nails.
- f) Do not let lamps rest on the supply cord or on any wire.
- g) Unplug the product when leaving the house, when retiring for the night, or if left unattended.
- h) This is an electric product-not a toy! To avoid risk of fire burns, personal injury and electric shock it should not be played with or placed where small children can reach it.
- i) Do not use this product for other than its intended use.
- j) Do not hang ornaments or other objects from cord, wire, or light string.
- k) Do not close doors or windows on the product or extension cords as this may damage the wire insulation.
- l) Do not cover the product with cloth, paper or any material not part of the product when in use.
- m) This product is equipped with push-in type lamps. Do not twist lamps.
- n) Read and follow all instructions that are on the product or provided with the product.

o) **SAVE THESE INSTRUCTIONS**

MADE IN CHINA

## Use and Care Instructions

- Before using or reusing, inspect product carefully. Discard any products that have cut, damaged, or frayed wire insulation or cords, cracks in the lampholders or enclosures, loose connections or exposed copper wire.
- When storing the product, carefully remove the product from wherever it is placed, including trees, branches, or bushes, to avoid any undue strain or stress on the product conductors, connections, and wires.
- When not in use, store neatly in a cool, dry location protected from sunlight.

## USER SERVICING INSTRUCTIONS

### Lamp Replacement:

**Step 1:** Grasp plug and remove from the receptacle or other outlet device. Do not unplug by pulling on cord.

**Step 2:** Lift up to unsnap locking tab, then pull lamp and plastic base straight out of lampholder.

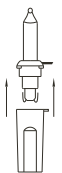

**Step 3:** Replace lamp with only 3.6 Volt, 0.072 watt or 2.4 Volt, 0.048 Watt LED type lamps provided with this product.

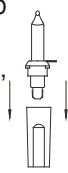

(Reference figure only)

If the new lamp base does not fit in lamp holder, follow the step below before Step 3.

- Remove the base or burned out lamp by straightening lamp leads and gently pull lamp out.
- Thread leads of new lamp through holes in old base with one lead in each hole.
- After lamp is fully inserted into base, bend each lead up, like other lamps in the light set so that the leads will touch the contacts inside the lampholder.

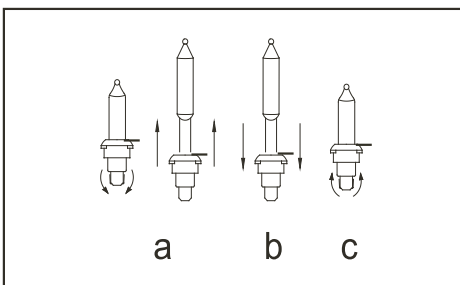

## CAUTION:

- Risk of fire. This product does not contain lamp shunts, which allow the product to operate if one lamp burns out. Replace lamps only with the spare lamps provided with this product.
- To reduce the risk of fire and electric shock: a) Do not install on trees having needles, leaves or branch coverings of metal or materials which look like metal, and b) Do not mount or support strings in a manner that can cut or damage wire insulation.

## PRODUCT SPECIFICATION

### Description

Grow and Stow tree is an indoor Christmas Tree provided with a electromechanical system for multiple height adjustment. Powered by a switching power supply (adaptor), It can be control by a foot pedal and a RF remote control unit. This controller commands the mechanism for stow and deploy, as well as the lighting functions. The full lower section of the motorized tree is provided with quick set connectors, and this entire tree easily storages within a compact bag for convenient storage.

<b>Switching Power Supply (adaptor):</b>	Input AC110-240V, 50/60Hz, Output DC 29V/2A
<b>7.5ft Tree Grow Range (Vertical Stroke):</b>	Minimum: 6ft Maximum: 7.5ft Stroke: 1.5ft
<b>9ft Tree Grow Range (Vertical Stroke):</b>	Minimum: 7ft Maximum 9ft Stroke: 2ft
<b>Tree Life Cycle:</b>	3000 Cycles Max.
<b>Remote Controller Range:</b>	33 ft (10m)
<b>Remote Controller Power</b>	DC 3V
<b>Operational Temperature:</b>	0°C to 40°C, 85% Humidity, indoor use
<b>Storage Temperature:</b>	-5°C to 60°C, 85% Humidity

### Accessories Included:

Foot Pedal, Remote hand set, adaptor, power cord, owner manual

# Grow And Stow Tree Part Table

Drawing No.	Description	Qty
1	AC Power Cord	1
2	AC/DC Power Adaptor	1
3	Adaptor AC input jacks	
4	Adaptor DC output jacks	
5	Tree trunk base	1
6	Tree control male 4 pin connector, to foot pedal	1
7	Light string male 2 pin connector, to foot pedal	1
8	Tree stand with fixed wheels and swiveling casters	1
9	Caster locks	
10	Tree foliage, lower section	
11	Light strings connectors set	1
12	Quick set guide funnel and female socket	1
13	Quick set male connector	
14	Tree top section	1

Key	Description	Qty
15	Foot Pedal unit	1
16	Foot pedal - Light Functions Push button	
17	Foot pedal - Grow / Pause/ Stow Push button	
18	Foot pedal - Safety Lock Switch	
19	Foot pedal - 2pin male connector to power adaptor DC jack	
20	Foot pedal - 4pin female connector to tree control	
21	Foot pedal - 2pin female connector to light string	

Key	Description	Qty
22	Remote Control handset	1
23	Remote LED indicator	
24	Remote light functions button	
25	Remote grow (Up and Pause) button	
26	Remote stow (Down and Pause) button	
27	Remote battery compartment and lid	

Key	Description	Qty
	Tree bag/pouch - Accessories (small)	1
	Tree bag - tree head	1
	Tree bag - tree Main	1

# ASSEMBLY INSTRUCTIONS

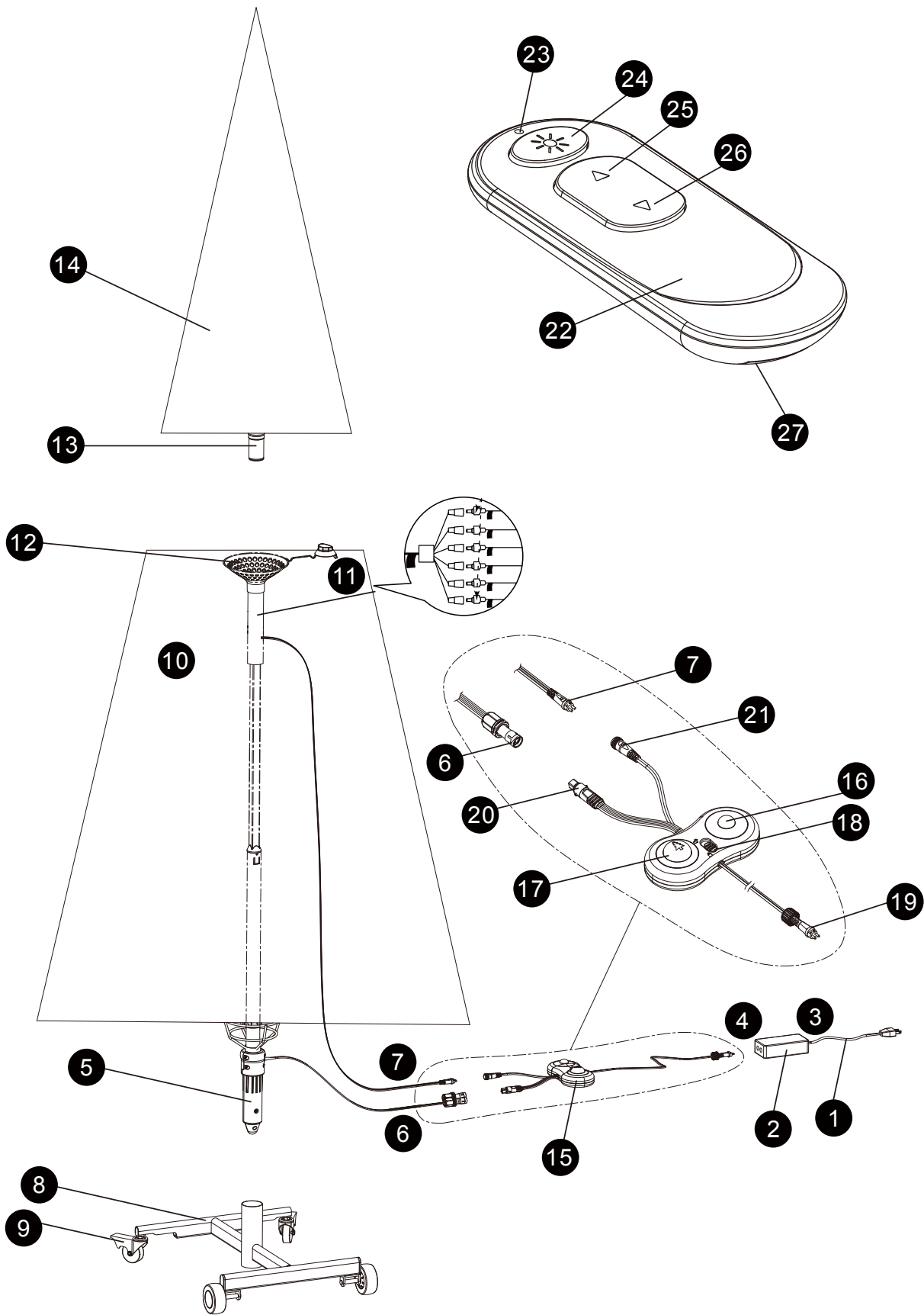

Main Diagram

# SET UP INSTRUCTION

## Unpack Carton box

- 1.1 Place the tree box on an upright position (long side along the vertical direction). See the arrows marked on the box for reference.
- 1.2 Untie the wrap string around the carton box, knife or cutter may be required (not included).
- 1.3 Pull up the top carton cover by the side hole handles (one on each side of carton box).
- 1.4 Remove the tree head section out of the box and open the tree head bag.
- 1.5 Remove the foam pads under the front wheels of the stand (swiveling casters Fig 1). The hard board under the stand will tip down creating a slight slope.
- 1.6 Pull the tree out of the carton box carefully.
- 1.7 Unlock the buckles on the tree bag, and loose the tree bag rope.
- 1.8 Open the tree bag wide and pull it up from the top of the tree.

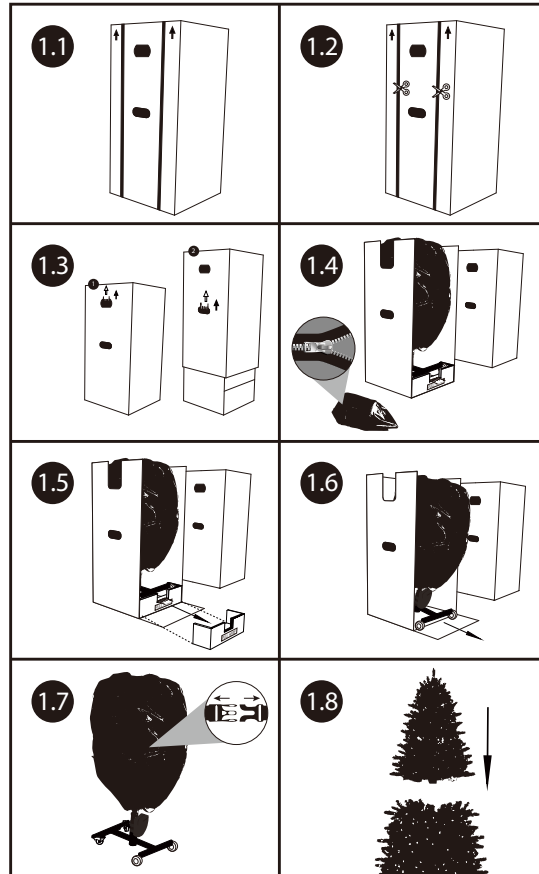
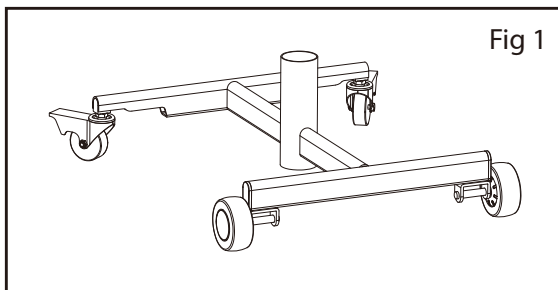

## Tree Assembly

- 2.1 Open and remove the protective cap from the top of the funnel guide 12 before inserting the tree top section 14.
- 2.2 Inserts the tree top section 14 into top funnel guide 12 of main section (see Fig 2)

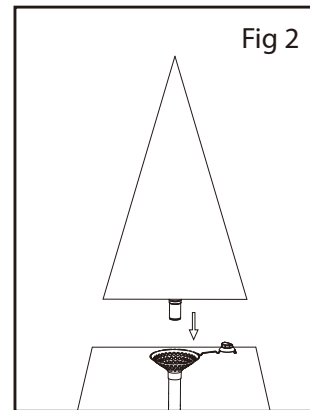

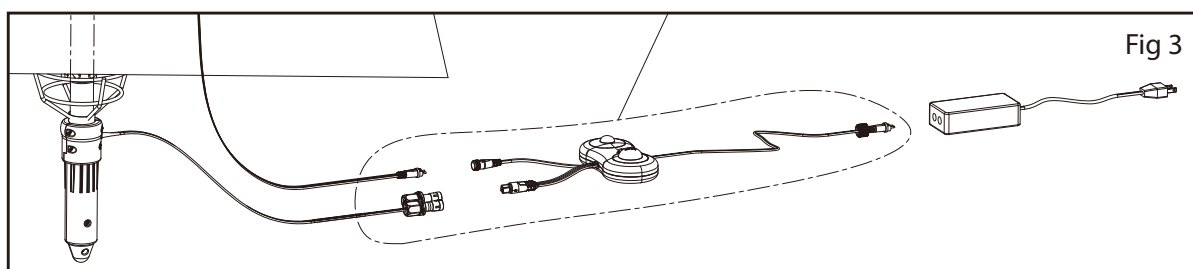

## Wire Connection

- 3.1 All accessories are stored in a small pouch 28, attached near the tree wheel stand. Open the pouch and put all accessories ready for use. (all wires display as seen on fig 3)
- 3.2 Connect the 2pin and 4pin connectors coming from the base of the tree to their counterpart connectors on the foot pedal (As shown on fig. 3). Make sure to lock them by turning the sockets.
- 3.3 Plug the pedal 2 pin connector 19 into the DC Power Adaptor output jack 4. Turn and lock with the socket.
- 3.4 Plug the Power adaptor AC cord 1 into an AC outlet.
- 3.5 The tree is energized and ready to be operated.



## Tree Operation by Foot Pedal (Fig 4)

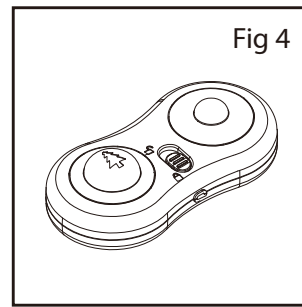

- 4.1 Double check all connections are properly and securely done **19** **20** **21** (see fig 3), and make sure the lock switch **18** is on "unlock"  position .
- 4.2 Push the tree logo button **17** on foot pedal to start toggling between Grow, Pause, and Stow functions.
- 4.3 Push the light button **16** on foot pedal to navigate the light string functions.
- 4.4 Note:  
 If your foot pedal is 3 flashing mode model, your remote handset can control light flash with 3 kind modes (clear steady, multi steady, clear multi alternating )  
 If your foot pedal is the 8 flashing modes model, your tree will cycle between 8 flashing modes (clear multi fading, clear fading, clear multi alternating, steady clear, clear multi slow fading, multi steady, multi fading, and combination )  
 If your foot pedal is the 10 flashing modes model, your tree will cycle between 10 flashing modes (clear steady/ clear fading/ multi steady/ multi fading/ clear multi fading/ clear multi alternating / pastel steady/ pastel fading/ clear pastel multi alternating/ clear pastel multi fading)
- 4.5 Slide lock switch **18** on foot pedal to function lock or unlock. Grow and stow function is lock for foot pedal and remote when in "lock"  position.



## Tree Shaping and Final Touches

- 5.1 After growing the tree to a desired height, allow all branches to fall into place. Additionally, gently pull them up and out until in place. For aesthetical purposes, make sure that all branches are tilted down and unfolded.
- 5.2 Continue to shape up the branches and tips working from the top down. Start with tips farthest from the trunk, and move towards the inner ones.
- 5.3 After shaping the entire tree as previously recommended, slightly upsweep all branch tips for a uniform look. Shift branches to fill any gaps. Your Christmas tree is now complete and ready to be decorated.  
 NOTE: It is highly recommended to operate the grow and stow functions ONLY when the tree is free of any ornament or decoration.

## Remote Hand Set Batteries Installation

- 6.1 Remove the battery lid **27** at the back of remote control, install the two AAA/UM4/LR03 batteries( not included) properly as indicated on the battery compartment. Make sure to match the (+) and (-) ends of the batteries . (see fig 5)
- 6.2 Buttons on the remote handset buttons are non-functional when the foot pedal lock switch **18** is set to "lock"  position. Make sure the switch is set to "unlock"  position. (see Fig 4)
- 6.3 Press light mode button **24** to navigate the light functions.

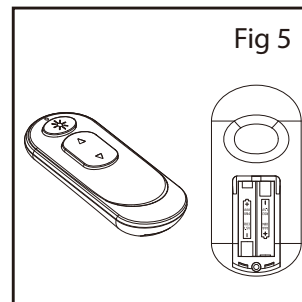

- Note:  
 If your foot pedal is 3 flashing mode model, your remote handset can control light flash with 3 kind modes (clear steady, multi steady, clear multi alternating )  
 If your foot pedal is the 8 flashing modes model, your tree will cycle between 8 flashing modes (clear multi fading, clear fading, clear multi alternating, steady clear, clear multi slow fading, multi steady, multi fading, and combination )  
 If your foot pedal is the 10 flashing modes model, your tree will cycle between 10 flashing modes (clear steady/ clear fading/ multi steady/ multi fading/ clear multi fading/ clear multi alternating / pastel steady/ pastel fading/ clear pastel multi alternating/ clear pastel multi fading)
- 6.4 Press UP button **25** on remote hand set to control tree Grow or Pause functions (toggle).
- 6.5 Press DOWN button **26** on remote to controls Stow or Pause functions (toggle).

## Storage Instructions

- 7.1 **IMPORTANT:** Remove all ornaments and decorations.
- 7.2 Set the Grow and Stow tree to its minimum size. (fig 6)
- 7.3 Detach the AC power cord ❶ from AC outlet, and put all accessories parts into the accessories stow pouch ❷.
- 7.4 Collect all wires, controllers and accessories inside the stow pouch. And attach it to the trunk near wheel stand ❸. (Recommended)
- 7.5 Remove the tree top section ❹ from top funnel guide. Fold all branches towards the pole and stow it inside the tree top bag ❺.
- 7.6 Gently fold up main section branches if needed.
- 7.7 Place the main tree bag ❻ around the tree main section, warping the tree from top to bottom. Zip it until fully closed.
- 7.8 Cinch tight the nylon rope on the bottom side of the main tree bag, the strap will hold its position once you release the spring clamp.
- 7.9 Buckle the straps until you hear a firm click. Then cinch the straps tightly by pulling at the end of the loose strap.
- 7.10 When not in use, store the tree in a cool, dry place away from sunlight. Exposing the tree to excessive heat or humidity may damage the tree.

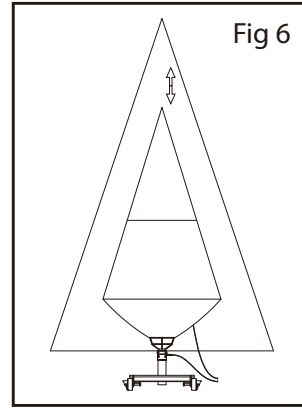

## REPLACEMENT PARTS ORDERING INFORMATION

No	DESCRIPTION	Drawing No.	PART No.	qty
1	AC power cord	1		x1
2	AC/DC adaptor	2		x1
3	Rolling wheel tree stand	8		x1
4	quick set funnel	12		x1
5	Tree head section	14		x1
6	Foot Pedal unit	15		x1
7	Remote control handset	22		x1
8	Tree bag - Accessories (small)	28		x1
9	Tree bag - tree head	29		x1
10	Tree bag - tree Main	30		x1
11	hinge pins and washers			x1
12	LED light bulb			?

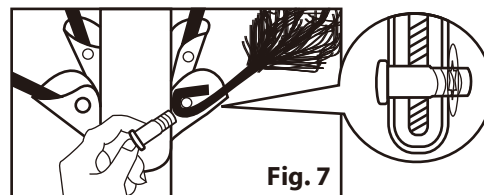

SPARE PARTS ?	
hinge pins and washers	
LED light bulb	





# TROUBLESHOOTING GUIDE

**WARNING:** UNPLUG THE POWER CORD BEFORE TROUBLESHOOTING THE GROW & STOW TREE.

SYMPTOM		CAUSE	SOLUTION
1	No power on	A. Adaptor is not plugged In	A. Adaptor must be plugged into an AC outlet.
		B. Foot pedal wires not connected	B. Foot pedal wire must be plugged into a DC jack of adaptor, and other wires to tree
		C. Low voltage	C. Check line voltage - must be 105 to 240 AC volts.
2	Tree mechanism does not works	A. Foot pedal set on "LOCK"  position	A. Set the lock switch to "UNLOCK"  position
		B. wires no connected	B. Make sure all wires are properly connected and locked. (see fig.3)
3	Remote control no work	A. Batteries out of power	A. Replace a brand new AAA/UM4/LR03 batteries
		B. Batteries install wrong polarity	B. Check batteries polarity diagram inside the batteries case. (see fig 5)
		C. You may out of effective range	C. Ensure the remote is operated within the range (10 meters)
4	No light on	A. LED light string connector no connected	A. Check all connectors of light string (plugs and jacks) are connected on trunk (see main diagram point ①)
		B. LED light bulb missing or damage	B. Extra LED light bulb are included for replace an spare LED light bulb
		C. Light string cord no connected to Foot pedal	C. Make sure the light string cord is connected to foot paddle and lock with ring screw.(see fig.3)
5	Tree tilts	A. Wheel stand set on unflat ground	A. Adjust the whole tree to flat ground surface.
6	The tree not complete up or down	A. Tree branches and Tips make jam each other	A. Adjust pull the branches and tips up and out direction. Prevent they cross jam together.
		B. remote or foot pedal was pressed PAUSE function	B. Press the button again on remote or foot pedal to release PAUSE (see fig. 4)
7	Loose Hinge Pin		A. Extra hinge pins are included for repairing the hinges. Insert a new hinge pin through the hold and secure using the retainer washer (see fig. 7 )

## FCC VERIFICATION USER MANUAL

This device complies with Part 15 of the FCC Rules. Operation is subject to the following two conditions: (1) this device may not cause harmful interference, and (2) this device must accept any interference received, including interference that may cause undesired operation.

**WARNING:** Changes or modifications to this unit not expressly approved by the party responsible for compliance could void the user's authority to operate the equipment.

**NOTE:** This equipment has been tested and found to comply with the limits for a Class B digital device, pursuant to Part 15 of the FCC Rules. These limits are designed to provide reasonable protection against harmful interference in a residential installation. This equipment generates, uses and can radiate radio frequency energy and, if not installed and used in accordance with the instructions, may cause harmful interference to radio communications.

However, there is no guarantee that interference will not occur in a particular installation. If this equipment does cause harmful interference to radio or television reception, which can be determined by turning the equipment off and on, the user is encouraged to try to correct the interference by one or more of the following measures:

- Reorient or relocate the receiving antenna.
- Increase the separation between the equipment and receiver.
- Connect the equipment into an outlet on a circuit different from that to which the receiver is connected.
- Consult the dealer or an experienced radio/TV technician for help.



IC Caution.

RSS-Gen Issue 4 November 2014" & "CNR-Gen 4e édition November 2014:

- English:

This device complies with Industry Canada licence-exempt RSS standard(s).

Operation is subject to the following two conditions: (1) This device may not cause interference, and (2) This device must accept any interference, including interference that may cause undesired operation of the device.

- French:

Le présent appareil est conforme aux CNR d'Industrie Canada applicables aux appareils radio exempts de licence. L'exploitation est autorisée aux deux conditions suivantes:

(1) l'appareil ne doit pas produire de brouillage, et

(2) l'utilisateur de l'appareil doit accepter tout brouillage radioélectrique subi, même si le brouillage est susceptible d'en compromettre le fonctionnement.