

RF Test Report

Applicant : OpenPath Security, Inc.
Product Type : Single Door Controller
Trade Name : openpath
Model Number : OP-2ESH-POE
Applicable Standard : FCC 47 CFR PART 15 SUBPART C
ANSI C63.10:2013
Received Date : Dec. 27, 2019
Test Period : Jan. 20 ~ Feb. 03, 2020
Issued Date : Feb. 07, 2020

Issued by

A Test Lab Techno Corp.
No. 140-1, Changan Street, Bade District,
Taoyuan City 33465, Taiwan (R.O.C.)
Tel : +886-3-2710188 / Fax : +886-3-2710190



Taiwan Accreditation Foundation accreditation number: 1330

Test Firm MRA designation number: TW0010

Note:

- 1.The test results are valid only for samples provided by customers and under the test conditions described in this report.
- 2.This report shall not be reproduced except in full, without the written approval of A Test Lab Technology Corporation.
- 3.The relevant information is provided by customers in this test report. According to the correctness, appropriateness or completeness of the information provided by the customer, if there is any doubt or error in the information which affects the validity of the test results, the laboratory does not take the responsibility.



Revision History

Rev.	Issued Date	Revisions	Revised By
00	Feb. 07, 2020	Initial Issue	Yu Chiang

Verification of Compliance

Issued Date: Feb. 07, 2020

Applicant : OpenPath Security, Inc.
Product Type : Single Door Controller
Trade Name : openpath
Model Number : OP-2ESH-POE
FCC ID : 2APJV2ESH
EUT Rated Voltage : DC Input : DC 24/12 V, 1.1/2.2 A
PoE Input : DC 48 V, 0.55 A
Test Voltage : 120 Vac / 60 Hz
Applicable Standard : FCC 47 CFR PART 15 SUBPART C
ANSI C63.10:2013
Test Result : Complied
Performing Lab. : A Test Lab Techno Corp.
No. 140-1, Changan Street, Bade District,
Taoyuan City 33465, Taiwan (R.O.C.)
Tel : +886-3-2710188 / Fax : +886-3-2710190
Taiwan Accreditation Foundation accreditation number: 1330
<http://www.atl-lab.com.tw/e-index.htm>



A Test Lab Techno Corp. tested the above equipment in accordance with the requirements set forth in the above standards. All indications of Pass/Fail in this report are opinions expressed by A Test Lab Techno Corp. based on interpretations and/or observations of test results. The test results show that the equipment tested is capable of demonstrating compliance with the requirements as documented in this report.

Approved By



(Manager)

(Fly Lu)



TABLE OF CONTENTS

1	General Information	5
1.1.	Summary of Test Result	5
1.2.	Measurement Uncertainty	6
2	EUT Description.....	6
3	Test Methodology.....	7
3.1.	Mode of Operation.....	7
3.2.	EUT Test Step.....	7
3.3.	Configuration of Test System Details.....	8
3.4.	Test Instruments	10
3.5.	Test Site Environment.....	11
4	Measurement Procedure.....	12
4.1.	AC Power Line Conducted Emission Measurement.....	12
4.2.	Radiated Emission Measurement.....	14
4.3.	Maximum Conducted Output Power Measurement.....	18
4.4.	6 dB RF Bandwidth Measurement.....	19
4.5.	Maximum Power Density Measurement.....	20
4.6.	Out of Band Conducted Emissions Measurement.....	21
4.7.	Antenna Measurement	21
5	Test Results	22
Annex A.	Conducted Emission	22
Annex B.	Conducted Test Results	24
Annex C.	Radiated Emission Measurement.....	31



1 General Information

1.1. Summary of Test Result

Standard	Item	Result	Remark
15.207	AC Power Conducted Emission	PASS	-----
15.247(d)	Transmitter Radiated Emissions	PASS	-----
15.247(b)(3)	Max. Output Power	PASS	-----
15.247(a)(2)	6 dB RF Bandwidth	PASS	-----
15.247(e)	Maximum Power Spectral Density	PASS	-----
15.247(d)	Out of Band Conducted Spurious Emission	PASS	-----
15.203	Antenna Requirement	PASS	-----

Standard	Description
CFR47, Part 15, Subpart C	Intentional Radiators
ANSI C63. 10: 2013	American National Standard of Procedures for Compliance Testing of Unlicensed Wireless Devices
KDB 558074 D01 15.247 Meas Guidance v05r02	GUIDANCE FOR COMPLIANCE MEASUREMENTS ON DIGITAL TRANSMISSION SYSTEM, FREQUENCY HOPPING SPREAD SPECTRUM SYSTEM, AND HYBRID SYSTEM DEVICES OPERATING UNDER SECTION 15.247 OF THE FCC RULES



1.2. Measurement Uncertainty

Test Item	Frequency Range	Uncertainty (dB)
Conducted Emission	150 kHz ~ 30 MHz	2.68
Radiated Emission	9 kHz ~ 30 MHz	2.14
	30 MHz ~ 1000 MHz	4.99
	1000 MHz ~ 18000 MHz	4.99
	18000 MHz ~ 26500 MHz	4.23
	26500 MHz ~ 40000 MHz	4.39
Conducted Output Power	0.92 dB	
RF Bandwidth	4.79 %	
Power Spectral Density	0.92 dB	

Decision Rule

- Uncertainty is not included.
- Uncertainty is included.

2 EUT Description

Applicant	OpenPath Security, Inc. 13428 Maxella Ave, #866, Marina Del Rey, CA 90292	
Manufacturer	OpenPath Security, Inc. 13428 Maxella Ave, #866, Marina Del Rey, CA 90292	
Product Type	Single Door Controller	
Trade Name	openpath	
Model No.	OP-2ESH-POE	
FCC ID	2APJV2ESH	
Frequency Range	2402 ~ 2480 MHz	
Modulation Type	GFSK	
Operate Temp. Range	0 ~ 50 °C	
Antenna information	Type	Max. Gain (dBi)
	Embedded Antenna	2.7
RF Output Power	0.00367 W	

3 Test Methodology

3.1. Mode of Operation

Decision of Test ATL has verified the construction and function in typical operation. All the test modes were carried out with the EUT in normal operation, which was shown in this test report and defined as:

Test Mode
Mode 1: Transmit mode
Mode 2: LE, GFSK Continuous TX Mode

Software used to control the EUT for staying in continuous transmitting mode was programmed.

After verification, all tests were carried out with the worst case test modes.

By preliminary testing and verifying three axis (X, Y and Z) position of EUT transmitted status, it was found that "X axis" position was the worst, then the final test was executed the worst condition and test data were recorded in this report.

Note: The EUT was programmed to be in continuously transmitting mode and the transmit duty cycle is not less than 98 %.

3.2. EUT Test Step

1	Setup the EUT shown on "Configuration of Test System Details".
2	Turn on the power of all equipment.
3	Turn on TX function.
4	EUT run test program.

Measurement Software			
No.	Description	Software	Version
1	Conducted Emission	EZ EMC	1.1.4.3
2	Radiated Emission	EZ EMC	1.1.4.4

3.3. Configuration of Test System Details

Conducted Emission

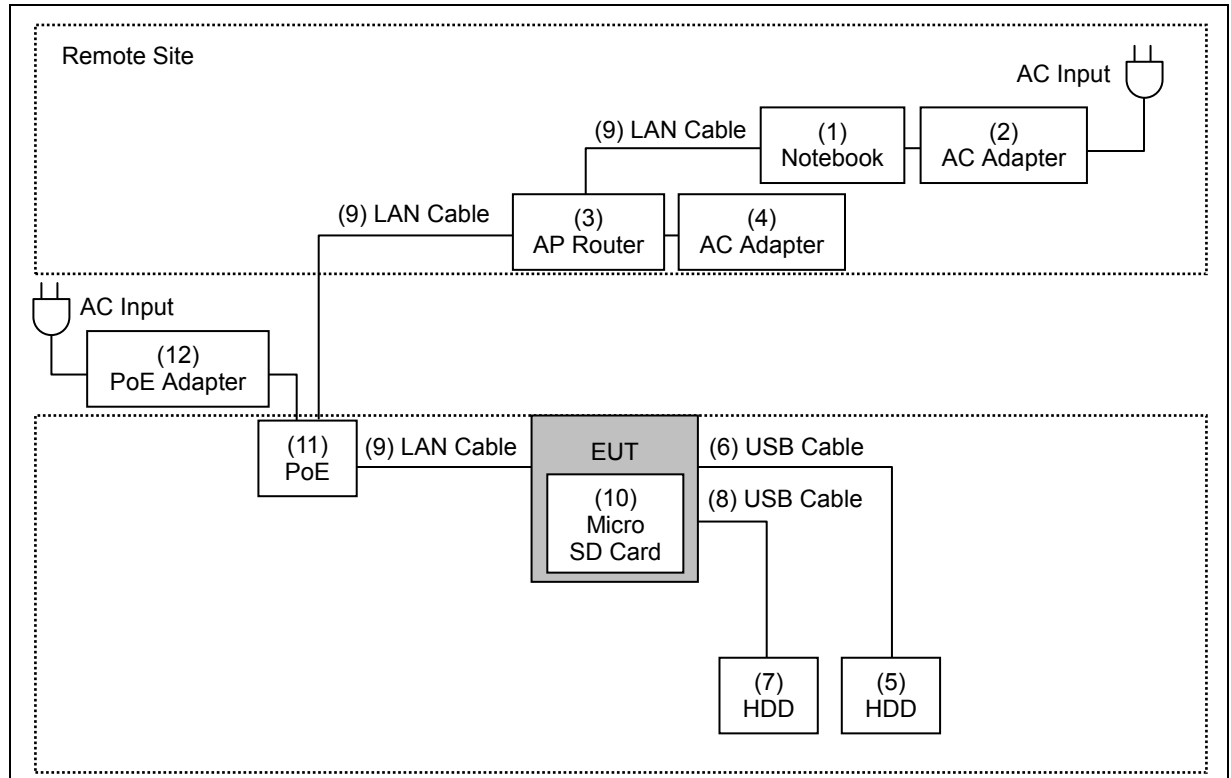

Radiated Emission

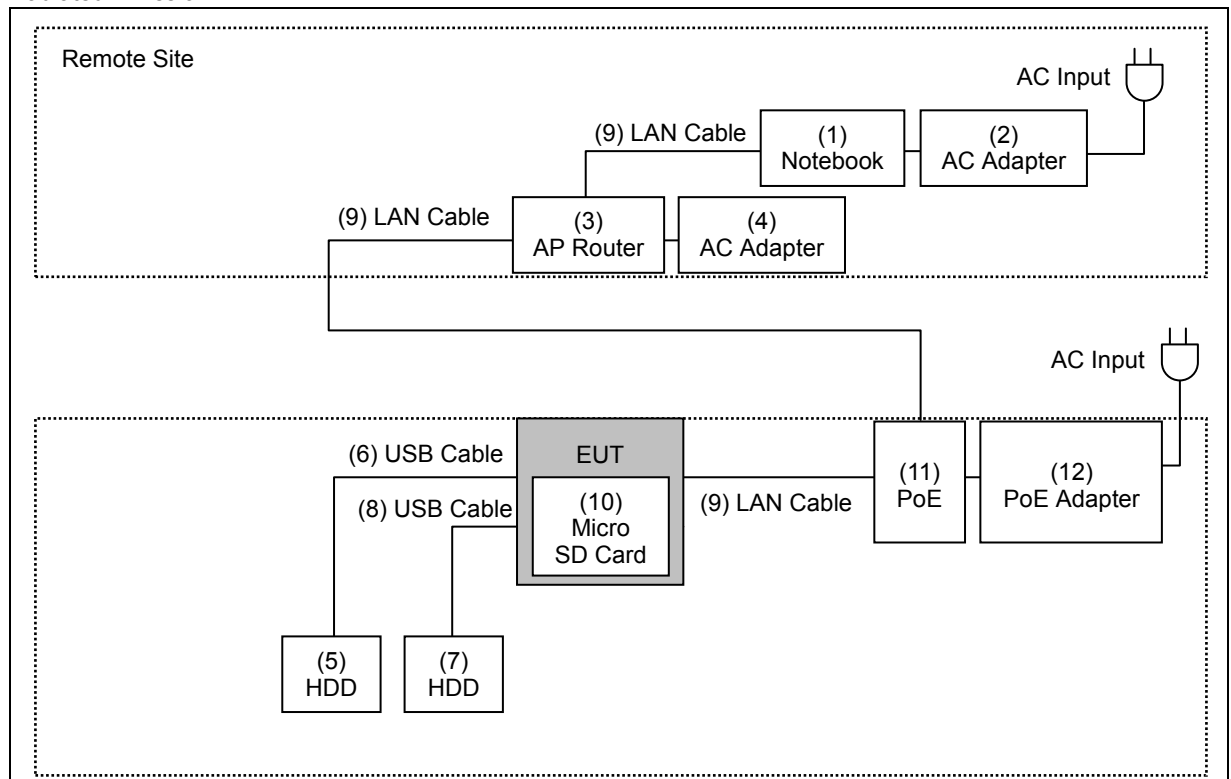



Devices Description					
Product		Manufacturer	Model Number	Serial Number	Power Cord
(1)	Notebook	ASUS	P2430U	GANXCV04H86940A	---
(2)	AC Adapter	ASUS	ADP-65GD B	---	Non-Shielded, 0.8 m
(3)	AP Router	NETGEAR	R7800	4H726754008FC	---
(4)	AC Adapter	NETGEAR	2AAF042F	332-10622-01	Non-Shielded, 1.8 m
(5)	HDD	Transend	TS1TSJ25A3K-RU	E40246-0203	---
(6)	USB Cable	Transend	TS1TSJ25A3K-RU	E40246-0203	No-Shielded, 0.8 m
(7)	HDD	Transend	TS1TSJ25A3K-RU	E40246-0204	---
(8)	USB Cable	Transend	TS1TSJ25A3K-RU	E40246-0204	No-Shielded, 0.8 m
(9)	LAN Cable	HUAWEI	UL2464	---	---
(10)	Micro SD Card	Transcend	UHS-I U1	---	---
(11)	POE	EDIMAX	PE-1000IPB	---	---
(12)	POE Adapter	JUNCTION GLOBAL TECHNOLOGY CO., LTD	ZZU1588-060540	---	Non-Shielded, 1.5 m



3.4. Test Instruments

For Conducted Emission

Test Period: Feb. 03, 2020

Testing Engineer: Louis Shen

Equipment	Manufacturer	Model Number	Serial Number	Cal. Date	Cal. Period
Test Receiver	R&S	ESCI	100367	05/23/2019	1 year
LISN	R&S	ENV216	101040	04/03/2019	1 year
LISN	R&S	ENV216	101041	03/28/2019	1 year
RF Cable	Woken	00100D1380194M	TE-02-03	05/23/2019	1 year

For Radiated Emissions

Test Period: Jan. 22 ~ Jan. 30, 2020

Testing Engineer: Ricky Liu

Equipment	Manufacturer	Model Number	Serial Number	Cal. Date	Cal. Period
Spectrum Analyzer (10 Hz~44 GHz)	Keysight	N9010A	MY52221312	01/13/2020	1 year
Pre Amplifier (1~26.5 GHz)	Agilent	8449B	3008A02237	10/18/2019	1 year
Pre Amplifier (100 kHz~1.3 GHz)	Agilent	8447D	2944A11119	01/15/2020	1 year
Pre Amplifier (26.5~40 GHz)	EMCI	EMC2654045	980028	08/23/2019	1 year
Broadband Antenna	Schwarzbeck	VULB9168	416	10/23/2019	1 year
Horn Antenna (1~18 GHz)	SCHWARZBECK MESS-ELEKTRONIK	BBHA9120D	9120D-550	08/22/2019	1 year
RF Cable	EMCI	EMC104-N-N-6000	TE01-1	02/20/2019	1 year
Microwave Cable	EMCI	EMC104-SM-SM-1 3000	170814	10/29/2019	1 year
Microwave Cable	EMCI	EMC102-KM-KM-1 4000	151001	02/20/2019	1 year

For Conducted

Test Period: Jan. 20 ~ Jan. 31, 2020

Testing Engineer: Negi.Chiu

Equipment	Manufacturer	Model Number	Serial Number	Cal. Date	Cal. Period
Spectrum Analyzer (20 Hz~26.5 GHz)	Agilent	N9020A	US47520902	09/18/2019	1 year
Power Sensor	Anritsu	MA2411B	1126022	09/03/2019	1 year
Power Meter	Anritsu	ML2495A	1135009	09/03/2019	1 year



3.5. Test Site Environment

Items	Required (IEC 60068-1)	Actual
Temperature (°C)	15-35	20-30
Humidity (%RH)	25-75	45-75
Barometric pressure (mbar)	860-1060	990-1005

4 Measurement Procedure

4.1. AC Power Line Conducted Emission Measurement

■ Limit

Frequency (MHz)	Quasi-peak	Average
0.15 - 0.5	66 to 56	56 to 46
0.50 - 5.0	56	46
5.0 - 30.0	60	50

■ Test Setup

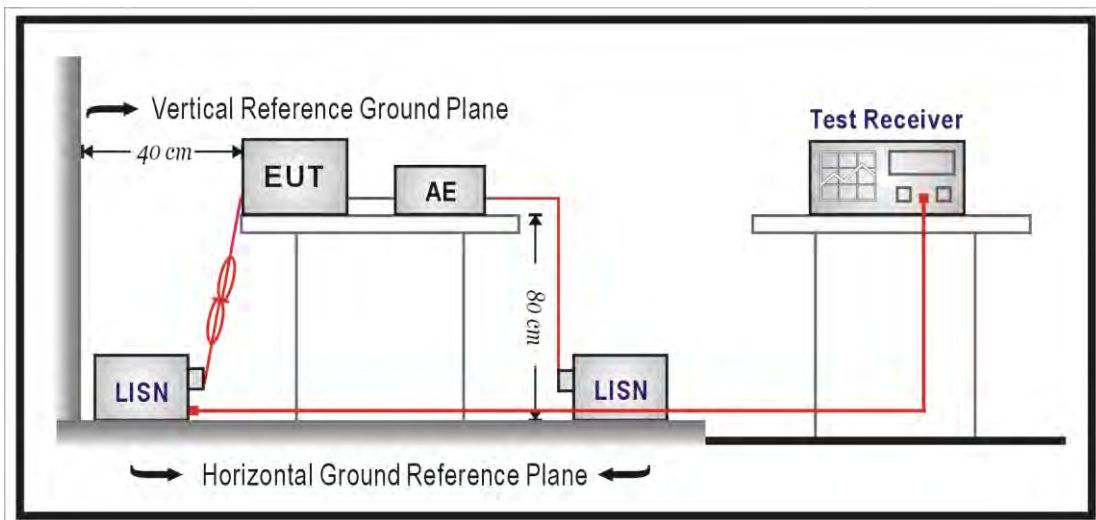

■ Test Procedure

The EUT and simulators are connected to the main power through a line impedance stabilization network (L.I.S.N.). This provides a $50 \Omega // 50 \mu\text{H}$ coupling impedance for the measuring equipment. The peripheral devices are also connected to the main power through a LISN that provides a $50 \Omega // 50 \mu\text{H}$ coupling impedance with 50 ohm termination.

Tabletop device shall be placed on a non-conducting platform, of nominal size 1 m by 1.5 m, raised 80 cm above the reference ground plane. The wall of screened room shall be located 40 cm to the rear of the EUT. Other surfaces of tabletop or floor standing EUT shall be at least 80 cm from any other ground conducting surface including one or more LISNs. For floor-standing device shall be placed under the EUT with a 12 mm insulating material.

Conducted emissions were investigated over the frequency range from 0.15 MHz to 30 MHz using a resolution bandwidth of 9 kHz. The equipment under test (EUT) shall be meet the limits in section 4.1, as applicable, including the average limit and the quasi-peak limit when using respectively, an average detector and quasi-peak detector measured in accordance with the methods described of related standard. When all of peak value were complied with quasi-peak and average limit from 150 kHz to 30 MHz then quasi-peak and average measurement was unnecessary.

The AMN shall be placed 0.8 m from the boundary of the unit under test and bonded to a ground reference plane for AMNs mounted on top of the ground reference plane. This distance is between the closest points of the AMN and the EUT. All other units of the EUT and associated equipment shall be at least 0.8 m from the AMN. If the mains power cable is longer than 1 m then the cable shall be folded back and forth at the centre of the lead to form a bundle no longer than 0.4 m. All of interconnecting cables that hang closer than 40 cm to the ground plane shall be folded back and forth in the center forming a bundle 30 cm to 40 cm long. All of EUT and AE shall be separate place more than 0.1 m. All 50 Ω ports of the LISN shall be resistively terminated into 50 Ω loads when not connected to the measuring instrument.

If the reading of the measuring receiver shows fluctuations close to the limit, the reading shall be observed for at least 15 s at each measurement frequency; the higher reading shall be recorded with the exception of any brief isolated high reading which shall be ignored.

4.2. Radiated Emission Measurement

■ Limit

According to §15.209(a), except as provided elsewhere in this subpart, the emissions from an intentional radiator shall not exceed the field strength levels specified in the following table:

Frequency (MHz)	Field Strength ($\mu\text{V}/\text{m}$ at meter)	Measurement Distance (meters)
0.009 – 0.490	$2400 / F$ (kHz)	300
0.490 – 1.705	$24000 / F$ (kHz)	30
1.705 – 30.0	30	30
30 - 88	100**	3
88-216	150**	3
216-960	200**	3
Above 960	500	3

** Except as provided in paragraph (g), fundamental emissions from intentional radiators operating under this Section shall not be located in the frequency bands 54-72 MHz, 76-88 MHz, 174-216 MHz or 470-806 MHz. However, operation within these frequency bands is permitted under other sections of this Part, e.g., Sections 15.231 and 15.241.

■ Setup

9 kHz ~ 30 MHz

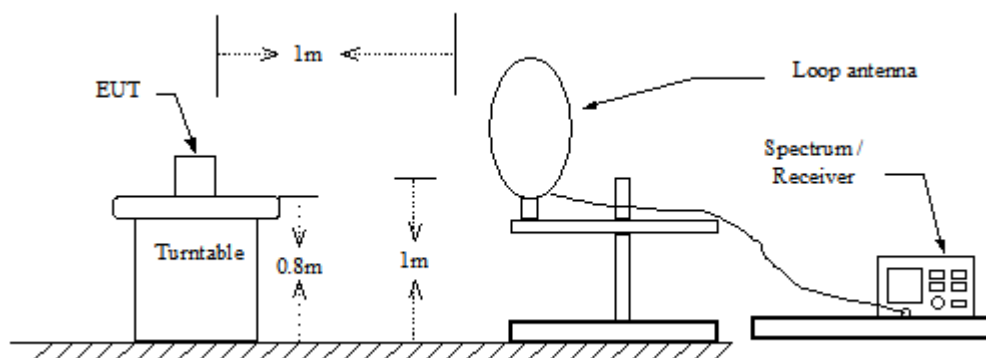

Below 1 GHz

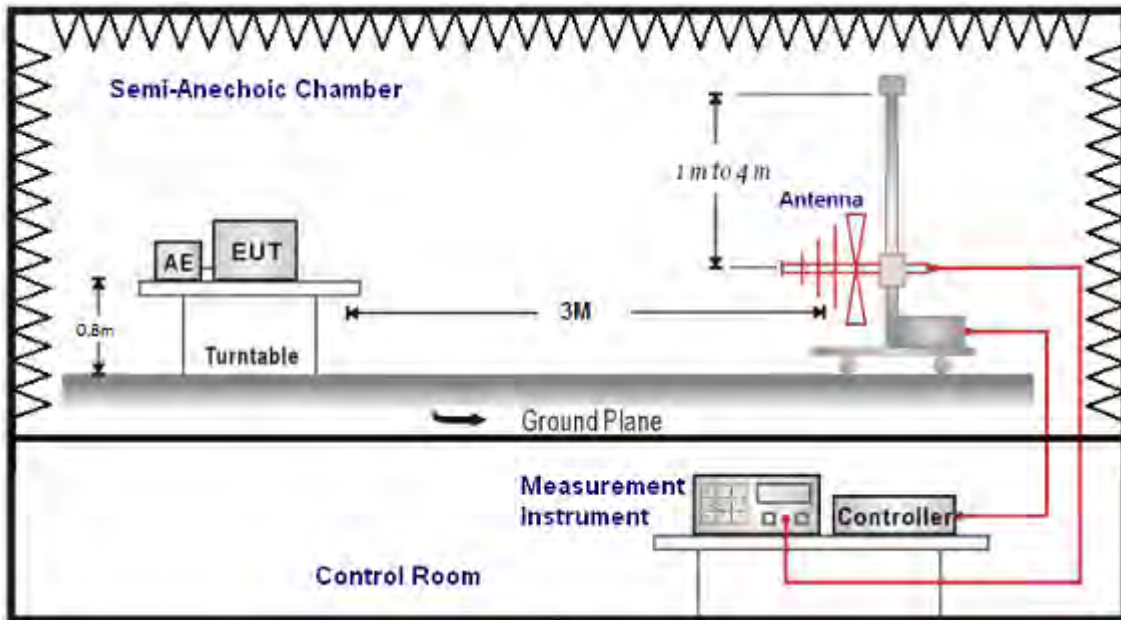

Above 1 GHz

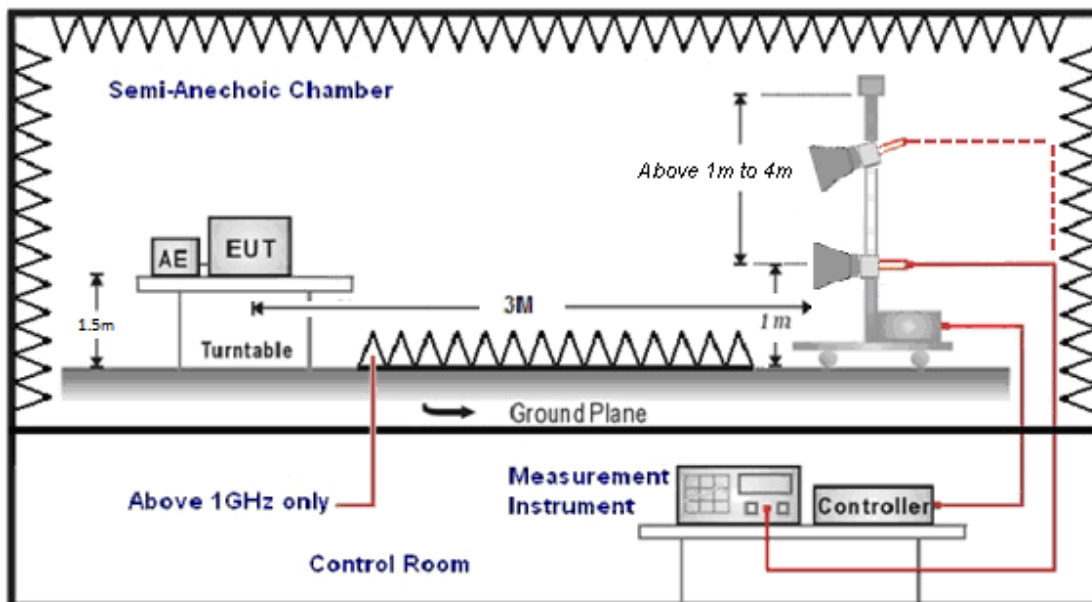

■ Test Procedure

Final radiation measurements were made on a three-meter, Semi Anechoic Chamber. The EUT system was placed on a nonconductive turntable which is 0.8 or 1.5 meters height, top surface 1.0 x 1.5 meter. The spectrum was examined from 250 MHz to 2.5 GHz in order to cover the whole spectrum below 10th harmonic which could generate from the EUT. During the test, EUT was set to transmit continuously & Measurements spectrum range from 9 kHz to 26.5 GHz is investigated.

For measurements below 1 GHz the resolution bandwidth is set to 100 kHz for peak detection measurements or 120 kHz for quasi-peak detection measurements. Peak detection is used unless otherwise noted as quasi-peak.

For measurements above 1 GHz the resolution bandwidth is set to 1 MHz, and then the video bandwidth is set to 3 MHz for peak measurements and 10 Hz for average measurements when Duty cycle >0.98 / $1/T$ for average measurements when Duty cycle <0.98 . A nonconductive material surrounded the EUT to supporting the EUT for standing on three orthogonal planes. At each condition, the EUT was rotated 360 degrees, and the antenna was raised and lowered from one to four meters to find the maximum emission levels. Measurements were taken using both horizontal and vertical antenna polarization.

SCHWARZBECK MESS-ELEKTRONIK Biconilog Antenna at 3 Meter and the SCHWARZBECK Double Ridged Guide Antenna was used in frequencies 1 –26.5 GHz at a distance of 3 meter. The antenna at an angle toward the source of the emission. All test results were extrapolated to equivalent signal at 3 meters utilizing an inverse linear distance extrapolation Factor (20 dB/decade).

For testing above 1 GHz, the emission level of the EUT in peak mode was 20 dB lower than average limit (that means the emission level in peak mode also complies with the limit in average mode), then testing will be stopped and peak values of EUT will be reported, otherwise, the emissions will be measured in average mode again and reported.

Appropriate preamplifiers were used for improving sensitivity and precautions were taken to avoid overloading or desensitizing the spectrum analyzer. No post – detector video filters were used in the test.

The spectrum analyzer's 6 dB bandwidth was set to 1 MHz, and the analyzer was operated in the peak detection mode, for frequencies both below and up 1 GHz. The average levels were obtained by subtracting the duty cycle correction factor from the peak readings.

The following procedures were used to convert the emission levels measured in decibels referenced to 1 microvolt (dBuV) into field intensity in micro volts pre meter ($\mu\text{V}/\text{m}$).

The actual field intensity in decibels referenced to 1 microvolt in to field intensity in micro volts per meter (dBuV/m).



The actual field intensity in referenced to 1 microvolt per meter (dBuV/m) is determined by algebraically adding the measured reading in dBuV, the antenna factor (dB), and cable loss (dB) and Subtracting the gain of preamplifier (dB) is auto calculate in spectrum analyzer.

$$(1) \text{ Amplitude (dBuV/m) = FI (dBuV) +AF (dBuV) +CL (dBuV)-Gain (dB)}$$

FI= Reading of the field intensity.

AF= Antenna factor.

CL= Cable loss.

P.S Amplitude is auto calculate in spectrum analyzer.

$$(2) \text{ Actual Amplitude (dBuV/m) = Amplitude (dBuV)-Dis(dB)}$$

The FCC specified emission limits were calculated according the EUT operating frequency and by following linear interpolation equations:

(a) For fundamental frequency : Transmitter Output < +30 dBm

(b) For spurious frequency : Spurious emission limits = fundamental emission limit /10

Data of measurement within this frequency range without mark in the table above means the reading of emissions are attenuated more than 20 dB below the permissible limits or the field strength is too small to be measured.

4.3. Maximum Conducted Output Power Measurement

■ Limit

For systems using digital modulation in the 2400-2483.5 MHz, the limit for peak output power is 30 dBm.

■ Test Setup

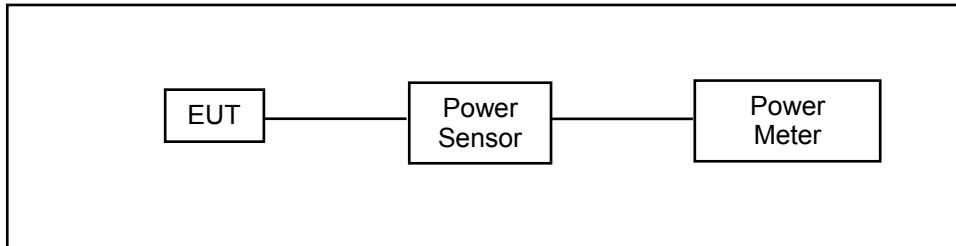

■ Test Procedure

The testing follows the Measurement Procedure of ANSI C63.10:2013 section 11.9.2.3.2 Method AVGPM.

The tests below are run with the EUT's transmitter set at high power in TX mode. The EUT is needed to force selection of output power level and channel number. While testing, EUT was set to transmit continuously. Remove the Subjective device's antenna and connect the RF output port to power sensor..

4.4. 6 dB RF Bandwidth Measurement

■ **Limit**

6 dB RF Bandwidth: Systems using digital modulation techniques may operate in the 2400–2483.5 MHz bands. The minimum 6 dB band-width shall be at least 500 kHz.

99 % Occupied Bandwidth: N/A

■ **Test Setup**

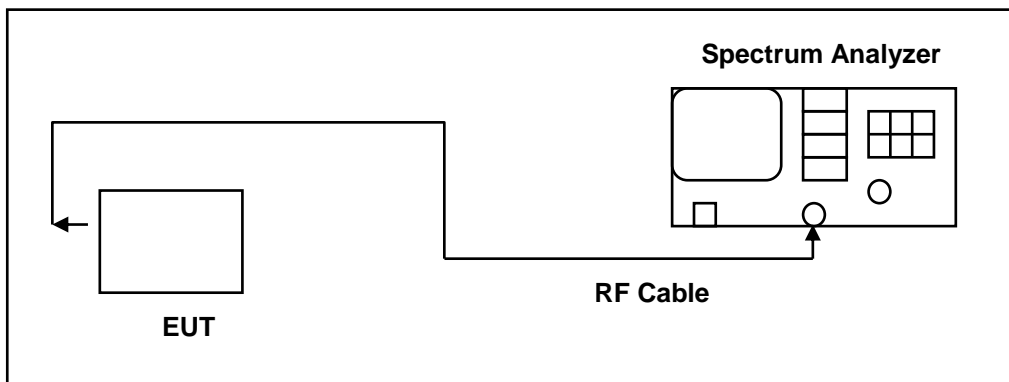

■ **Test Procedure**

The EUT tested to DTS test procedure of ANSI C63.10-2013 section 11.8.2 option2 for compliance to FCC 47CFR 15.247 requirements.

6 dB RF Bandwidth: The antenna port of the EUT was connected to the input of a spectrum analyzer. Analyzer RBW was set to 100 kHz. For each RF output channel investigated, the spectrum analyzer center frequency was set to the channel carrier. A peak output reading was taken, a DISPLAY line was drawn 6 dB lower than peak level. The 6 dB bandwidth was determined from where the channel output spectrum intersected the display line.

The test was performed at 3 channels (Channel low, middle, high)

4.5. Maximum Power Density Measurement

■ Limit

For digitally modulated systems, the power spectral density conducted from the intentional radiator to the antenna shall not be greater than 8 dBm in any 3 kHz band during any time interval of continuous transmission.

■ Test Setup

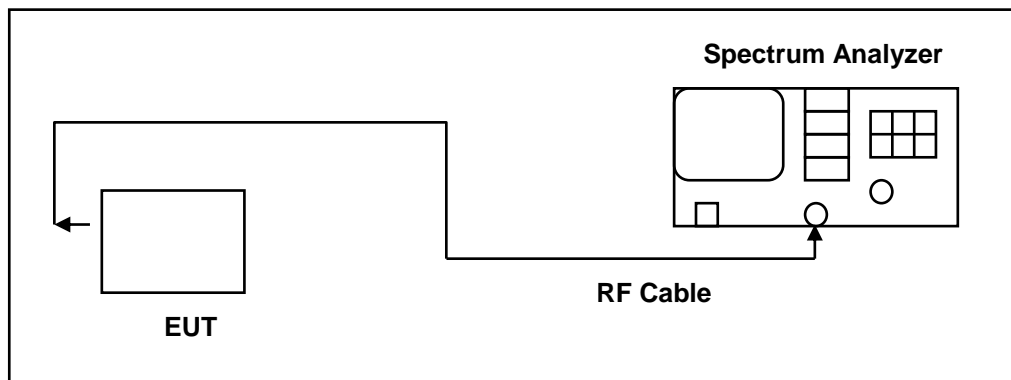

■ Test Procedure

The EUT tested to DTS test procedure of ANSI C63.10:2013 section 11.10.2 Method PKPSD.

1. Set analyzer center frequency to DTS channel center frequency.
2. Set the span to 1.5 times the DTS bandwidth.
3. Set the RBW to: $3 \text{ kHz} \leq \text{RBW} \leq 100 \text{ kHz}$.
4. Set the VBW $\geq 3 \times \text{RBW}$.
5. Detector = peak.
6. Sweep time = auto couple.
7. Trace mode = max hold.
8. Allow trace to fully stabilize.
9. Use the peak marker function to determine the maximum amplitude level within the RBW.
10. If measured value exceeds limit, reduce RBW (no less than 3 kHz) and repeat.

4.6. Out of Band Conducted Emissions Measurement

■ Limit

In any 100 kHz bandwidth outside the frequency band in which the spread spectrum or digitally modulated intentional radiator is operating, the radio frequency power that is produced by the intentional radiator shall be at least 30 dB below that in the 100 kHz bandwidth within the band that contains the highest level of the desired power

■ Test Setup

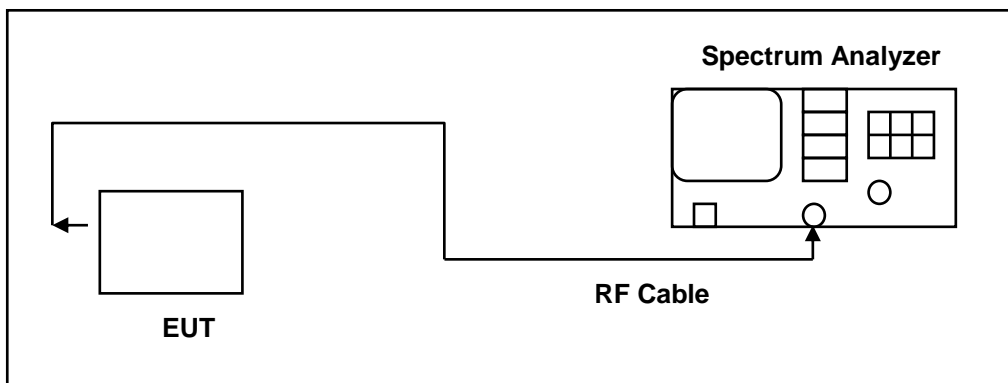

■ Test Procedure

In any 100 kHz bandwidth outside the EUT pass band, the RF power produced by the modulation products of the spreading sequence, the information sequence, and the carrier frequency shall be at least 30 dB below that of the maximum in-band 100 kHz emission, antenna output of the EUT was coupled directly to spectrum analyzer; if an external attenuator and/or cable was used, these losses are compensated for with the analyzer OFFSET function.

All other types of emissions from the EUT shall meet the general limits for radiated frequencies outside the pass band. The test was performed at 3 channels.

4.7. Antenna Measurement

■ Limit

For intentional device, according to 15.203, an intentional radiator shall be designed to ensure that no antenna other than that furnished by the responsible party shall be used with the device.

And According to 15.247 (b), if transmitting antennas of directional gain greater than 6 dBi are used, the power shall be reduced by the amount in dB that the directional gain of the antenna exceeds 6 dBi.

■ Antenna Connector Construction

See section 2 – antenna information.

5 Test Results

Annex A. Conducted Emission

Standard:	FCC Part 15.247	Line:	L1
Test item:	Conducted Emission	Power:	AC 120 V/60 Hz
Mode:	Mode 1	Temp.(°C)/Hum.(%RH):	26(°C)/60 %RH
Description:			

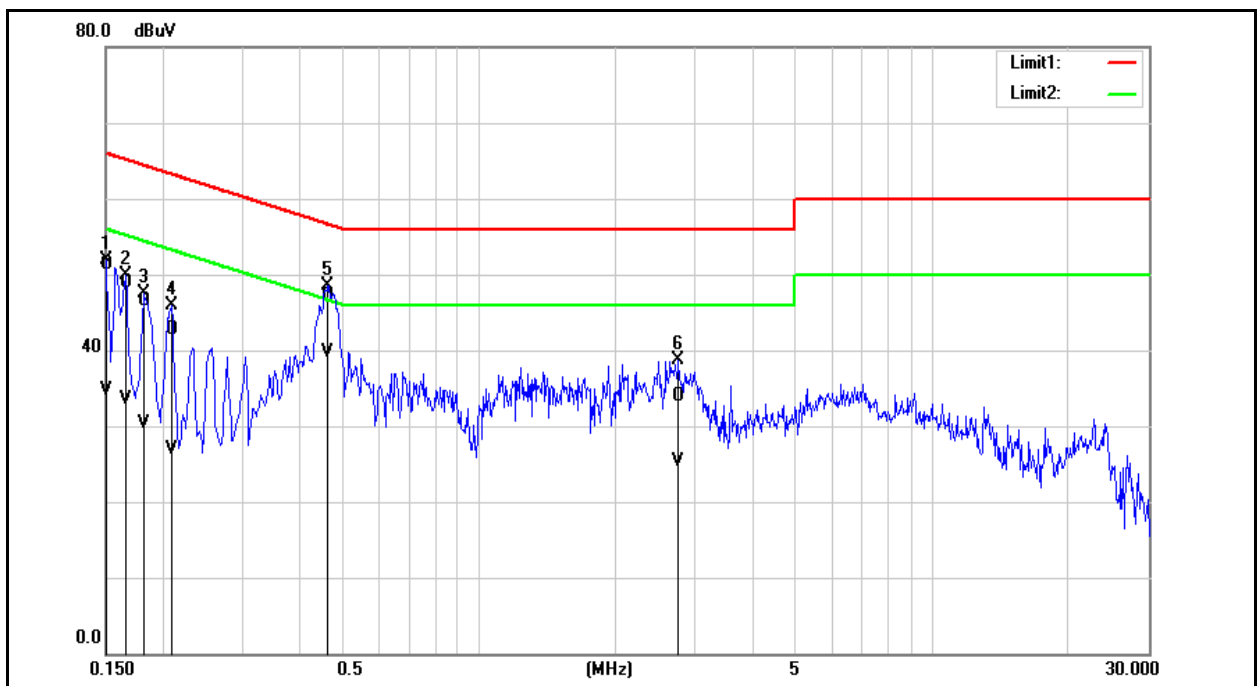

No.	Frequency (MHz)	QP reading (dBuV)	AVG reading (dBuV)	Correction factor (dB)	QP result (dBuV)	AVG result (dBuV)	QP limit (dBuV)	AVG limit (dBuV)	QP margin (dB)	AVG margin (dB)	Remark
1	0.1500	41.59	25.02	9.65	51.24	34.67	66.00	56.00	-14.76	-21.33	Pass
2	0.1660	39.26	23.76	9.65	48.91	33.41	65.16	55.16	-16.25	-21.75	Pass
3	0.1820	36.92	20.68	9.64	46.56	30.32	64.39	54.39	-17.83	-24.07	Pass
4	0.2100	33.03	17.32	9.64	42.67	26.96	63.21	53.21	-20.54	-26.25	Pass
5	0.4660	37.54	30.00	9.66	47.20	39.66	56.58	46.58	-9.38	-6.92	Pass
6	2.7540	24.25	15.55	9.74	33.99	25.29	56.00	46.00	-22.01	-20.71	Pass

Note: 1. Result (dBuV) = Correction factor (dB) + Reading(dBuV).

2. Correction factor (dB) = Cable loss (dB) + L.I.S.N. factor (dB).



Standard:	FCC Part 15.247	Line:	N
Test item:	Conducted Emission	Power:	AC 120 V/60 Hz
Mode:	Mode 1	Temp.(°C)/Hum.(%RH):	26(°C)/60 %RH
Description:			

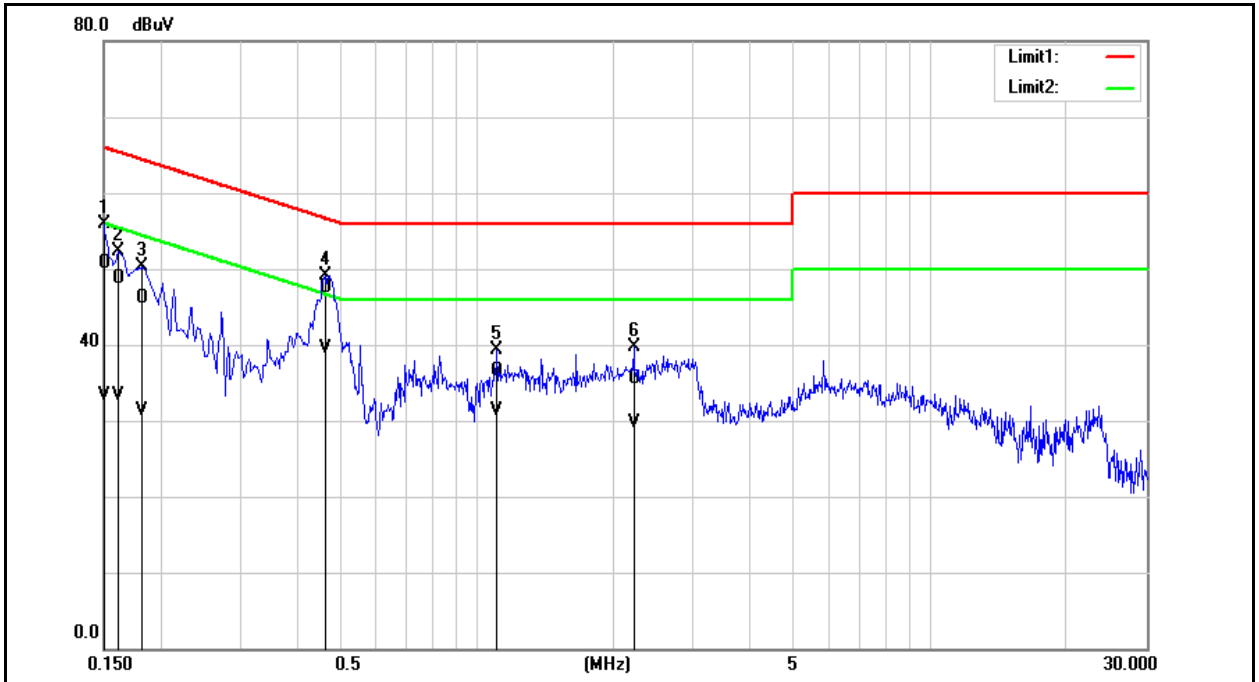

No.	Frequency (MHz)	QP reading (dBuV)	AVG reading (dBuV)	Correction factor (dB)	QP result (dBuV)	AVG result (dBuV)	QP limit (dBuV)	AVG limit (dBuV)	QP margin (dB)	AVG margin (dB)	Remark
1	0.1500	40.93	23.61	9.68	50.61	33.29	66.00	56.00	-15.39	-22.71	Pass
2	0.1620	39.04	23.53	9.68	48.72	33.21	65.36	55.36	-16.64	-22.15	Pass
3	0.1820	36.34	21.64	9.67	46.01	31.31	64.39	54.39	-18.38	-23.08	Pass
4	0.4620	37.82	29.87	9.69	47.51	39.56	56.66	46.66	-9.15	-7.10	Pass
5	1.1060	26.73	21.51	9.70	36.43	31.21	56.00	46.00	-19.57	-14.79	Pass
6	2.2140	25.85	19.98	9.75	35.60	29.73	56.00	46.00	-20.40	-16.27	Pass

Note: 1. Result (dBuV) = Correction factor (dB) + Reading(dBuV).
2. Correction factor (dB) = Cable loss (dB) + L.I.S.N. factor (dB).



Annex B. Conducted Test Results

Maximum Conducted Output Power Measurement

Test Mode	Mode 2		
Frequency (MHz)	Average Power		Limit (dBm)
	(dBm)	(W)	
2402	5.65	0.00367	≤ 30
2440	5.34	0.00342	≤ 30
2480	4.35	0.00272	≤ 30

Note: The relevant measured result has the offset with cable loss already.

6 dB RF Bandwidth Measurement

Test Mode	Mode 2	
Frequency (MHz)	Measurement Results (kHz)	Limit (kHz)
2402	720.600	≥ 500
2440	719.700	≥ 500
2480	720.000	≥ 500



■ Test Graphs

Mode 2	
2402 MHz	<p>Agilent Spectrum Analyzer - Occupied BW</p> <p>Center Freq: 2.402000000 GHz Trig: Free Run #Atten: 20 dB Avg/Hold: 1/1 Radio Device: BTS</p> <p>Ref Offset 1 dB Ref 20.00 dBm</p> <p>Center 2.402 GHz #Res BW 100 kHz #VBW 300 kHz Span 3 MHz Sweep 1 ms</p> <p>Occupied Bandwidth 1.0900 MHz Total Power 12.6 dBm</p> <p>Transmit Freq Error -22.207 kHz OBW Power 99.00 % x dB Bandwidth 720.6 kHz x dB -6.00 dB</p> <p>Frequency Center Freq 2.402000000 GHz CF Step 300.000 kHz Freq Offset 0 Hz</p>
2440 MHz	<p>Agilent Spectrum Analyzer - Occupied BW</p> <p>Center Freq: 2.440000000 GHz Trig: Free Run #Atten: 20 dB Avg/Hold: 1/1 Radio Device: BTS</p> <p>Ref Offset 1 dB Ref 20.00 dBm</p> <p>Center 2.44 GHz #Res BW 100 kHz #VBW 300 kHz Span 3 MHz Sweep 1 ms</p> <p>Occupied Bandwidth 1.0875 MHz Total Power 12.4 dBm</p> <p>Transmit Freq Error -18.134 kHz OBW Power 99.00 % x dB Bandwidth 719.7 kHz x dB -6.00 dB</p> <p>Frequency Center Freq 2.440000000 GHz CF Step 300.000 kHz Freq Offset 0 Hz</p>
2480 MHz	<p>Agilent Spectrum Analyzer - Occupied BW</p> <p>Center Freq: 2.480000000 GHz Trig: Free Run #Atten: 20 dB Avg/Hold: 1/1 Radio Device: BTS</p> <p>Ref Offset 1 dB Ref 20.00 dBm</p> <p>Center 2.48 GHz #Res BW 100 kHz #VBW 300 kHz Span 3 MHz Sweep 1 ms</p> <p>Occupied Bandwidth 1.0900 MHz Total Power 11.2 dBm</p> <p>Transmit Freq Error -14.087 kHz OBW Power 99.00 % x dB Bandwidth 720.0 kHz x dB -6.00 dB</p> <p>Frequency Center Freq 2.480000000 GHz CF Step 300.000 kHz Freq Offset 0 Hz</p>



Maximum Power Density Measurement

Test Mode	Mode 2	
Frequency (MHz)	Measurement Results (dBm/ 3kHz)	Limit (dBm)
2402	-8.149	≤ 8
2440	-8.249	≤ 8
2480	-9.481	≤ 8





■ Test Graphs

Mode 2	
2402 MHz	<p>Agilent Spectrum Analyzer - Swept SA</p> <p>Ref Offset: 1 dB Ref: 11.00 dBm</p> <p>Mkr1 2.401 952 4 GHz -8.149 dBm</p> <p>Center 2.4020000 GHz #Res BW 3.0 kHz #VBW 10 kHz Sweep 114.0 ms (1001 pts)</p> <p>Frequency</p> <p>Auto Tune</p> <p>Center Freq 2.40200000 GHz</p> <p>Start Freq 2.401456500 GHz</p> <p>Stop Freq 2.402540500 GHz</p> <p>CF Step 108.100 kHz Auto Man</p> <p>Freq Offset 0 Hz</p>
2440 MHz	<p>Agilent Spectrum Analyzer - Swept SA</p> <p>Ref Offset: 1 dB Ref: 11.00 dBm</p> <p>Mkr1 2.439 956 80 GHz -8.249 dBm</p> <p>Center 2.4400000 GHz #Res BW 3.0 kHz #VBW 10 kHz Sweep 113.9 ms (1001 pts)</p> <p>Frequency</p> <p>Auto Tune</p> <p>Center Freq 2.44000000 GHz</p> <p>Start Freq 2.439460000 GHz</p> <p>Stop Freq 2.440540000 GHz</p> <p>CF Step 108.000 kHz Auto Man</p> <p>Freq Offset 0 Hz</p>
2480 MHz	<p>Agilent Spectrum Analyzer - Swept SA</p> <p>Ref Offset: 1 dB Ref: 11.00 dBm</p> <p>Mkr1 2.479 961 12 GHz -9.481 dBm</p> <p>Center 2.4800000 GHz #Res BW 3.0 kHz #VBW 10 kHz Sweep 113.9 ms (1001 pts)</p> <p>Frequency</p> <p>Auto Tune</p> <p>Center Freq 2.48000000 GHz</p> <p>Start Freq 2.479460000 GHz</p> <p>Stop Freq 2.480540000 GHz</p> <p>CF Step 108.000 kHz Auto Man</p> <p>Freq Offset 0 Hz</p>

Out of Band Conducted Emissions Measurement

■ Test Graphs

Reference level

Mode 2	
2402 MHz	
2440 MHz	
2480 MHz	

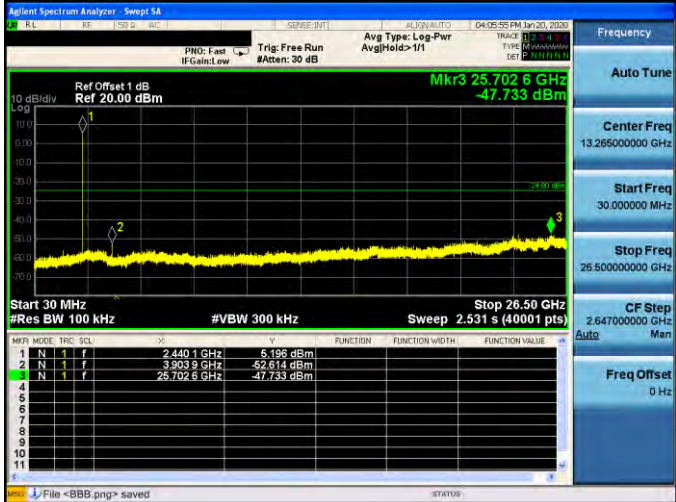
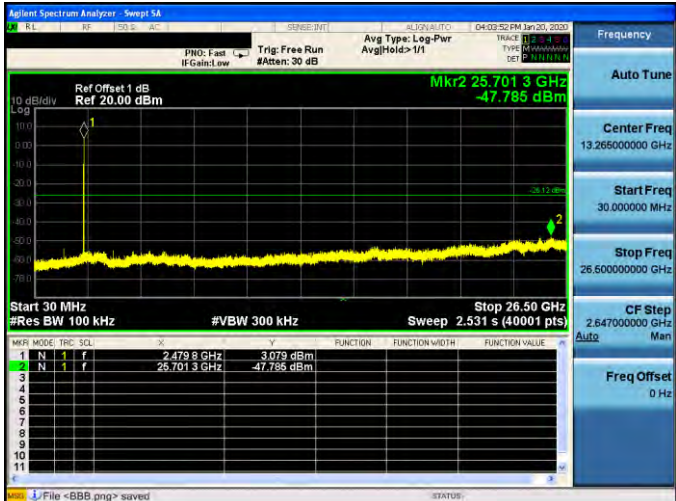

Out of Band Conducted Emissions

Mode 2																																					
<p>2402 MHz</p>	 <table border="1" data-bbox="646 772 1220 929"> <thead> <tr> <th>MKR</th> <th>MODE</th> <th>TRIG</th> <th>SQ</th> <th>F</th> <th>Y</th> <th>FUNCTION</th> <th>FUNCTION WIDTH</th> <th>FUNCTION VALUE</th> </tr> </thead> <tbody> <tr> <td>1</td> <td>N</td> <td>1</td> <td>f</td> <td>2.4017 GHz</td> <td>6.288 dBm</td> <td></td> <td></td> <td></td> </tr> <tr> <td>2</td> <td>N</td> <td>1</td> <td>f</td> <td>3.8430 GHz</td> <td>-52.221 dBm</td> <td></td> <td></td> <td></td> </tr> <tr> <td>3</td> <td>N</td> <td>1</td> <td>f</td> <td>25.7277 GHz</td> <td>-47.744 dBm</td> <td></td> <td></td> <td></td> </tr> </tbody> </table>	MKR	MODE	TRIG	SQ	F	Y	FUNCTION	FUNCTION WIDTH	FUNCTION VALUE	1	N	1	f	2.4017 GHz	6.288 dBm				2	N	1	f	3.8430 GHz	-52.221 dBm				3	N	1	f	25.7277 GHz	-47.744 dBm			
MKR	MODE	TRIG	SQ	F	Y	FUNCTION	FUNCTION WIDTH	FUNCTION VALUE																													
1	N	1	f	2.4017 GHz	6.288 dBm																																
2	N	1	f	3.8430 GHz	-52.221 dBm																																
3	N	1	f	25.7277 GHz	-47.744 dBm																																
<p>2440 MHz</p>	 <table border="1" data-bbox="646 1301 1220 1458"> <thead> <tr> <th>MKR</th> <th>MODE</th> <th>TRIG</th> <th>SQ</th> <th>F</th> <th>Y</th> <th>FUNCTION</th> <th>FUNCTION WIDTH</th> <th>FUNCTION VALUE</th> </tr> </thead> <tbody> <tr> <td>1</td> <td>N</td> <td>1</td> <td>f</td> <td>2.4401 GHz</td> <td>6.196 dBm</td> <td></td> <td></td> <td></td> </tr> <tr> <td>2</td> <td>N</td> <td>1</td> <td>f</td> <td>3.9039 GHz</td> <td>-52.614 dBm</td> <td></td> <td></td> <td></td> </tr> <tr> <td>3</td> <td>N</td> <td>1</td> <td>f</td> <td>25.7026 GHz</td> <td>-47.733 dBm</td> <td></td> <td></td> <td></td> </tr> </tbody> </table>	MKR	MODE	TRIG	SQ	F	Y	FUNCTION	FUNCTION WIDTH	FUNCTION VALUE	1	N	1	f	2.4401 GHz	6.196 dBm				2	N	1	f	3.9039 GHz	-52.614 dBm				3	N	1	f	25.7026 GHz	-47.733 dBm			
MKR	MODE	TRIG	SQ	F	Y	FUNCTION	FUNCTION WIDTH	FUNCTION VALUE																													
1	N	1	f	2.4401 GHz	6.196 dBm																																
2	N	1	f	3.9039 GHz	-52.614 dBm																																
3	N	1	f	25.7026 GHz	-47.733 dBm																																
<p>2480 MHz</p>	 <table border="1" data-bbox="646 1827 1220 1984"> <thead> <tr> <th>MKR</th> <th>MODE</th> <th>TRIG</th> <th>SQ</th> <th>F</th> <th>Y</th> <th>FUNCTION</th> <th>FUNCTION WIDTH</th> <th>FUNCTION VALUE</th> </tr> </thead> <tbody> <tr> <td>1</td> <td>N</td> <td>1</td> <td>f</td> <td>2.4798 GHz</td> <td>3.079 dBm</td> <td></td> <td></td> <td></td> </tr> <tr> <td>2</td> <td>N</td> <td>1</td> <td>f</td> <td>25.7013 GHz</td> <td>-47.785 dBm</td> <td></td> <td></td> <td></td> </tr> </tbody> </table>	MKR	MODE	TRIG	SQ	F	Y	FUNCTION	FUNCTION WIDTH	FUNCTION VALUE	1	N	1	f	2.4798 GHz	3.079 dBm				2	N	1	f	25.7013 GHz	-47.785 dBm												
MKR	MODE	TRIG	SQ	F	Y	FUNCTION	FUNCTION WIDTH	FUNCTION VALUE																													
1	N	1	f	2.4798 GHz	3.079 dBm																																
2	N	1	f	25.7013 GHz	-47.785 dBm																																

Conducted Band Edge

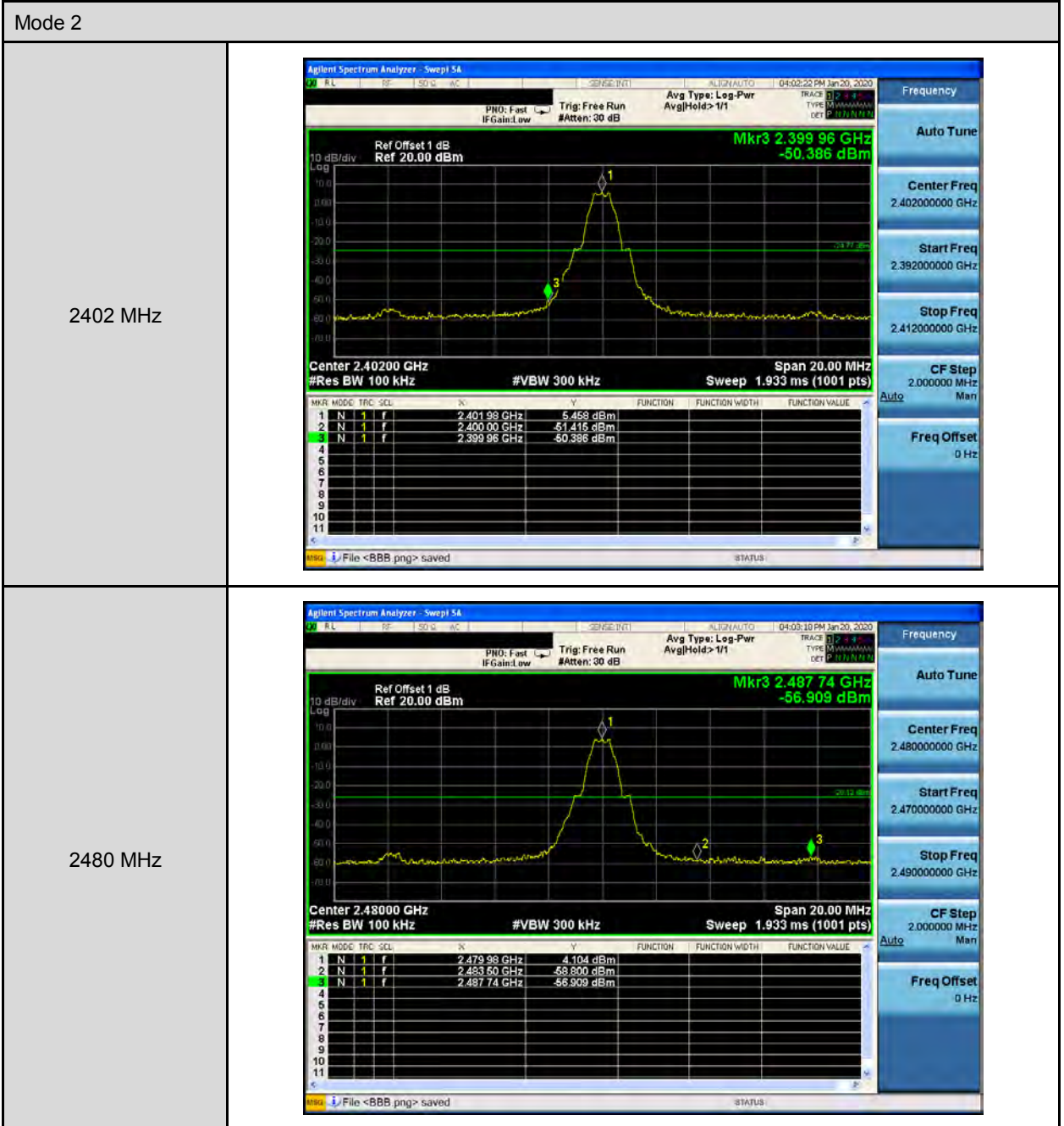



Annex C. Radiated Emission Measurement

Below 1 GHz

Standard:	FCC Part 15.247	Test Distance:	3 m				
Test item:	Radiated Emission	Power:	AC 120 V/60 Hz				
Mode:	Mode 1	Temp.(°C)/Hum.(%RH):	26(°C)/60 %RH				
Frequency (MHz)	Reading (dBuV)	Correct Factor (dB/m)	Result (dBuV/m)	Limit (dBuV/m)	Margin (dB)	Remark	Ant.Polar. H / V
175.5000	34.72	-6.52	28.20	43.50	-15.30	QP	H
340.4000	29.98	-3.32	26.66	46.00	-19.34	QP	H
500.4500	32.65	-0.36	32.29	46.00	-13.71	QP	H
625.5800	30.73	2.53	33.26	46.00	-12.74	QP	H
822.4900	26.54	5.96	32.50	46.00	-13.50	QP	H
893.3000	26.20	7.32	33.52	46.00	-12.48	QP	H
91.1100	43.26	-12.11	31.15	43.50	-12.35	QP	V
152.2200	32.72	-5.86	26.86	43.50	-16.64	QP	V
375.3200	31.94	-2.70	29.24	46.00	-16.76	QP	V
523.7300	33.07	0.13	33.20	46.00	-12.80	QP	V
695.4200	27.20	3.48	30.68	46.00	-15.32	QP	V
872.9300	27.15	6.85	34.00	46.00	-12.00	QP	V

Note:1.Result (dBuV/m) = Correct Factor (dB/m) + Reading(dBuV).

Example: 28.20 = -6.52+34.72

2.Correction factor (dB/m) = Antenna Factor (dB/m) + Cable loss (dB) – Pre-Amplifier gain (dB).

3.When the peak results are less than average limit, so not need to evaluate the average.



Harmonic

Above 1 GHz

Standard:	FCC Part 15.247	Test Distance:	3 m
Test item:	Harmonic	Power:	AC 120 V/60 Hz
Frequency:	2402 MHz	Temp.(°C)/Hum.(%RH):	25(°C)/60 %RH
Mode:	Mode 2		
Ant.Polar.:	Horizontal		

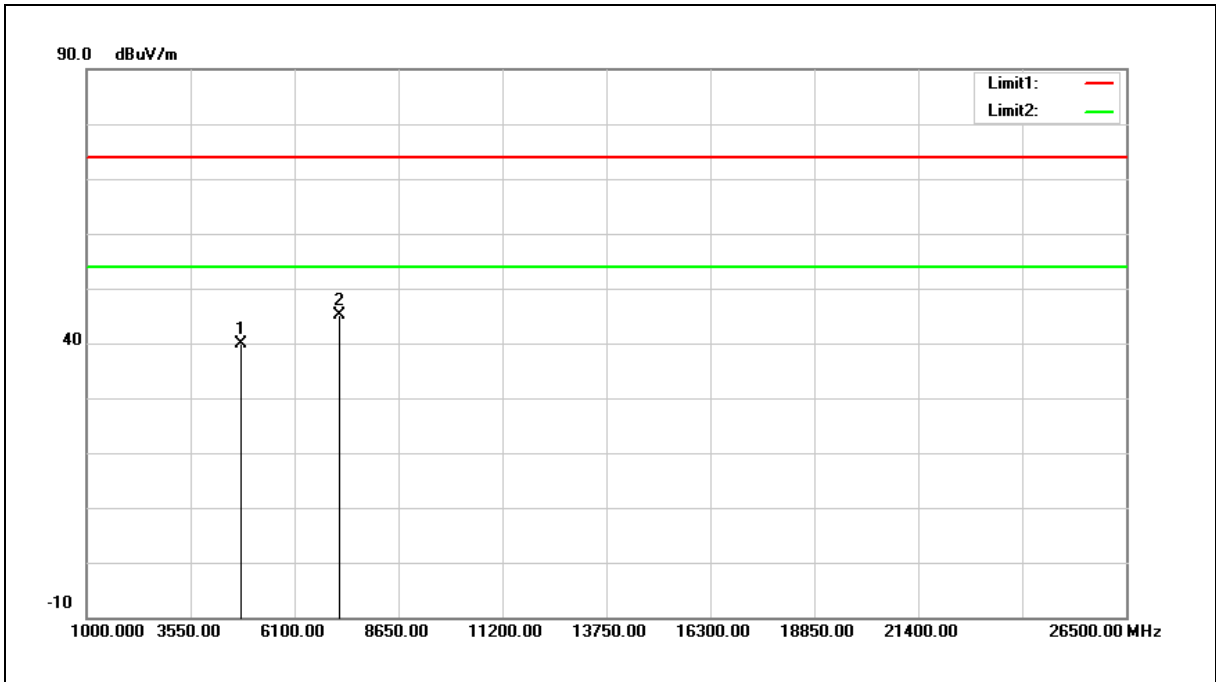

No.	Frequency (MHz)	Reading (dBuV)	Correct Factor (dB/m)	Result (dBuV/m)	Limit (dBuV/m)	Margin (dB)	Remark
1	4804.000	33.97	5.83	39.80	74.00	-34.20	peak
2	7206.000	32.76	12.32	45.08	74.00	-28.92	peak

Note: 1.Result (dBuV/m) = Correct Factor (dB/m) + Reading(dBuV).

Example: 39.80 = 5.83+33.97

2.Correction factor (dB/m) = Antenna Factor (dB/m) + Cable loss (dB) – Pre-Amplifier gain (dB).

3.When the peak results are less than average limit, so not need to evaluate the average.



Standard:	FCC Part 15.247	Test Distance:	3 m
Test item:	Harmonic	Power:	AC 120 V/60 Hz
Frequency:	2402 MHz	Temp.(°C)/Hum.(%RH):	25(°C)/60 %RH
Mode:	Mode 2		
Ant.Polar.:	Vertical		

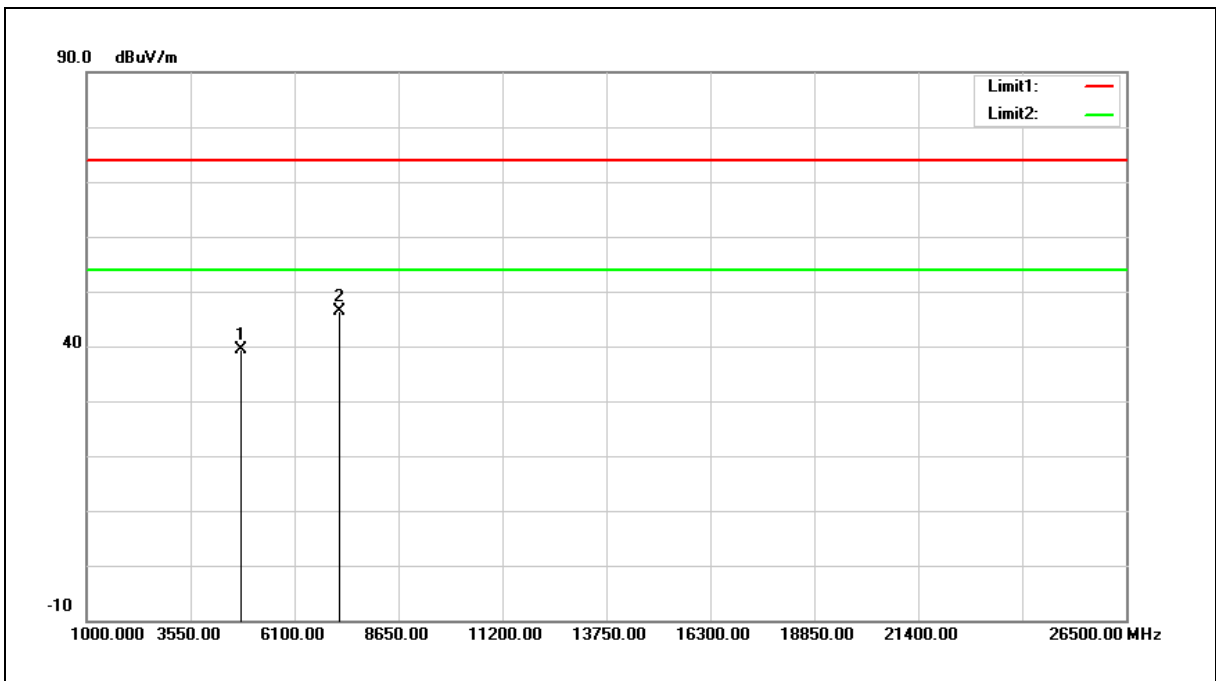

No.	Frequency (MHz)	Reading (dBuV)	Correct Factor (dB/m)	Result (dBuV/m)	Limit (dBuV/m)	Margin (dB)	Remark
1	4804.000	33.45	5.83	39.28	74.00	-34.72	peak
2	7206.000	34.17	12.32	46.49	74.00	-27.51	peak

Note: 1.Result (dBuV/m) = Correct Factor (dB/m) + Reading(dBuV).

Example: 39.28 = 5.83+33.45

2.Correction factor (dB/m) = Antenna Factor (dB/m) + Cable loss (dB) – Pre-Amplifier gain (dB).

3.When the peak results are less than average limit, so not need to evaluate the average.



Standard:	FCC Part 15.247	Test Distance:	3 m
Test item:	Harmonic	Power:	AC 120 V/60 Hz
Frequency:	2440 MHz	Temp.(°C)/Hum.(%RH):	25(°C)/60 %RH
Mode:	Mode 2		
Ant.Polar.:	Horizontal		

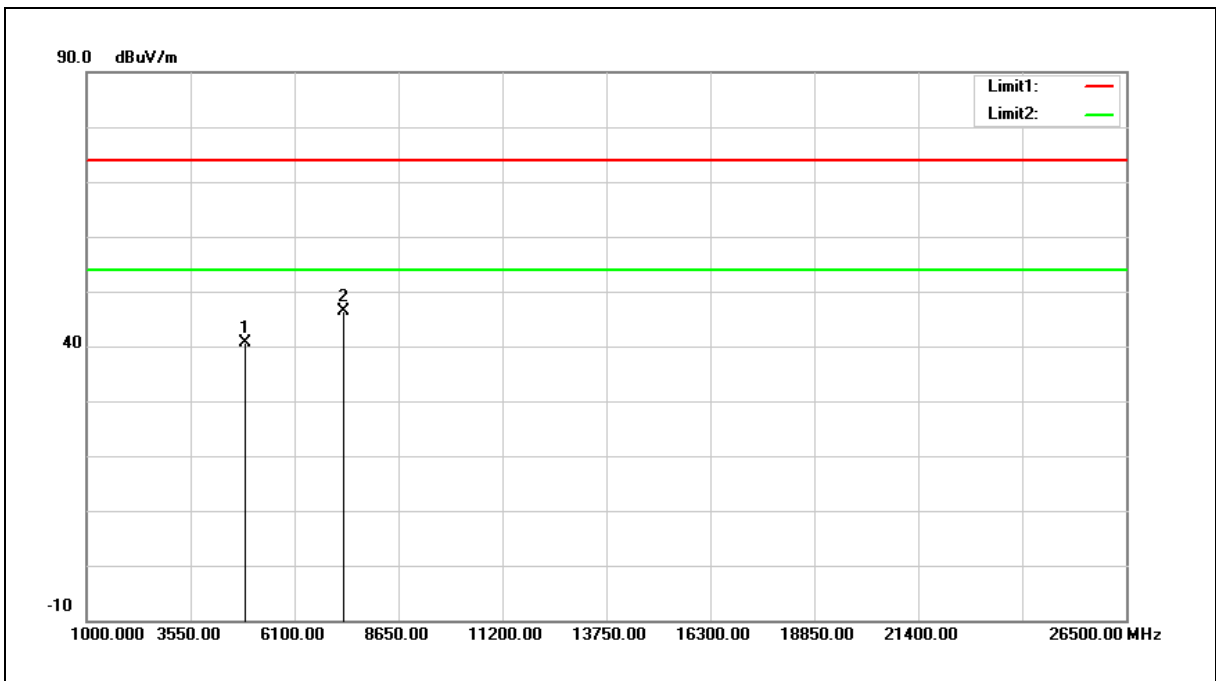

No.	Frequency (MHz)	Reading (dBuV)	Correct Factor (dB/m)	Result (dBuV/m)	Limit (dBuV/m)	Margin (dB)	Remark
1	4880.000	34.47	6.05	40.52	74.00	-33.48	peak
2	7320.000	33.66	12.71	46.37	74.00	-27.63	peak

- Note: 1.Result (dBuV/m) = Correct Factor (dB/m) + Reading(dBuV).
 2.Correction factor (dB/m) = Antenna Factor (dB/m) + Cable loss (dB) – Pre-Amplifier gain (dB).
 3.When the peak results are less than average limit, so not need to evaluate the average.



Standard:	FCC Part 15.247	Test Distance:	3 m
Test item:	Harmonic	Power:	AC 120 V/60 Hz
Frequency:	2440 MHz	Temp.(°C)/Hum.(%RH):	25(°C)/60 %RH
Mode:	Mode 2		
Ant.Polar.:	Vertical		

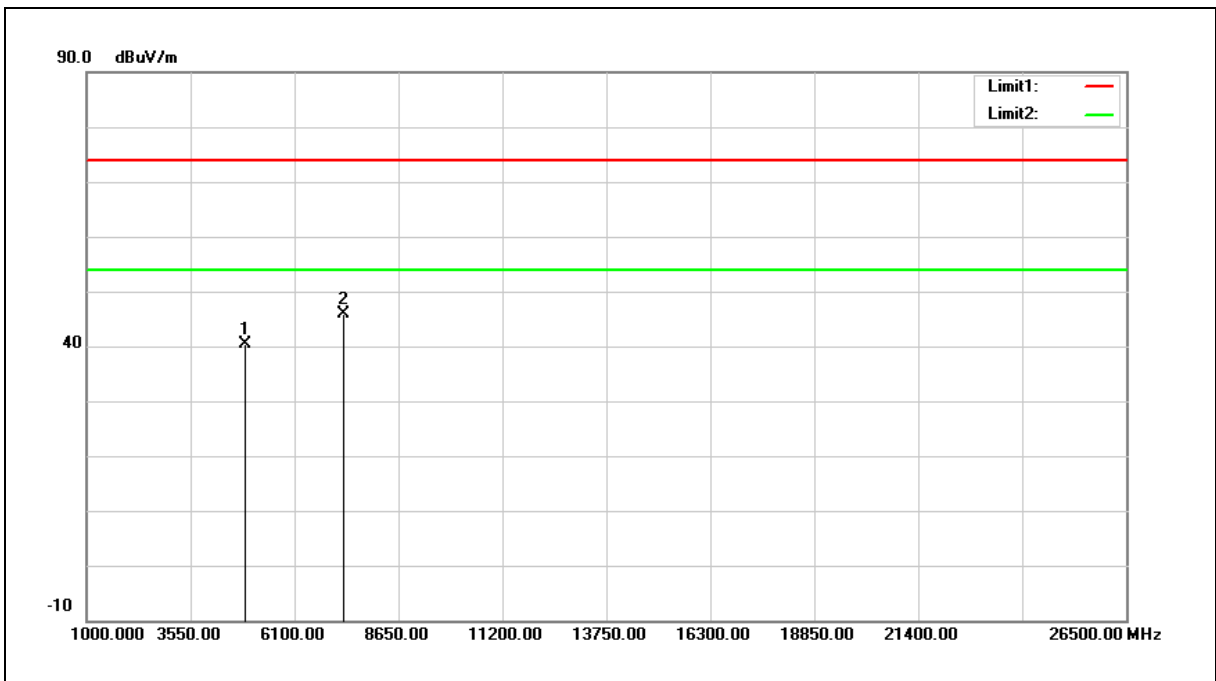

No.	Frequency (MHz)	Reading (dBuV)	Correct Factor (dB/m)	Result (dBuV/m)	Limit (dBuV/m)	Margin (dB)	Remark
1	4880.000	34.35	6.05	40.40	74.00	-33.60	peak
2	7320.000	33.09	12.71	45.80	74.00	-28.20	peak

Note: 1. Result (dBuV/m) = Correct Factor (dB/m) + Reading(dBuV).

2. Correction factor (dB/m) = Antenna Factor (dB/m) + Cable loss (dB) – Pre-Amplifier gain (dB).

3. When the peak results are less than average limit, so not need to evaluate the average.



Standard:	FCC Part 15.247	Test Distance:	3 m
Test item:	Harmonic	Power:	AC 120 V/60 Hz
Frequency:	2480 MHz	Temp.(°C)/Hum.(%RH):	25(°C)/60 %RH
Mode:	Mode 2		
Ant.Polar.:	Horizontal		

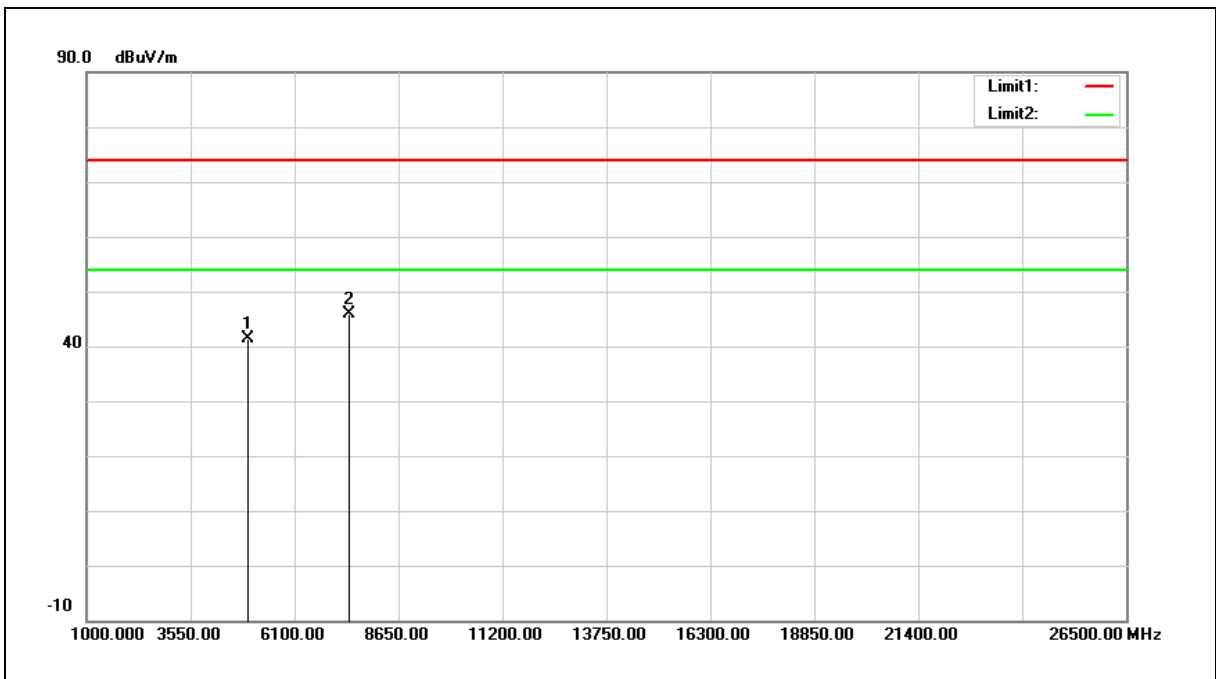

No.	Frequency (MHz)	Reading (dBuV)	Correct Factor (dB/m)	Result (dBuV/m)	Limit (dBuV/m)	Margin (dB)	Remark
1	4960.000	35.17	6.28	41.45	74.00	-32.55	peak
2	7440.000	32.75	13.13	45.88	74.00	-28.12	peak

- Note: 1.Result (dBuV/m) = Correct Factor (dB/m) + Reading(dBuV).
 2.Correction factor (dB/m) = Antenna Factor (dB/m) + Cable loss (dB) – Pre-Amplifier gain (dB).
 3.When the peak results are less than average limit, so not need to evaluate the average.



Standard:	FCC Part 15.247	Test Distance:	3 m
Test item:	Harmonic	Power:	AC 120 V/60 Hz
Frequency:	2480 MHz	Temp.(°C)/Hum.(%RH):	25(°C)/60 %RH
Mode:	Mode 2		
Ant.Polar.:	Vertical		

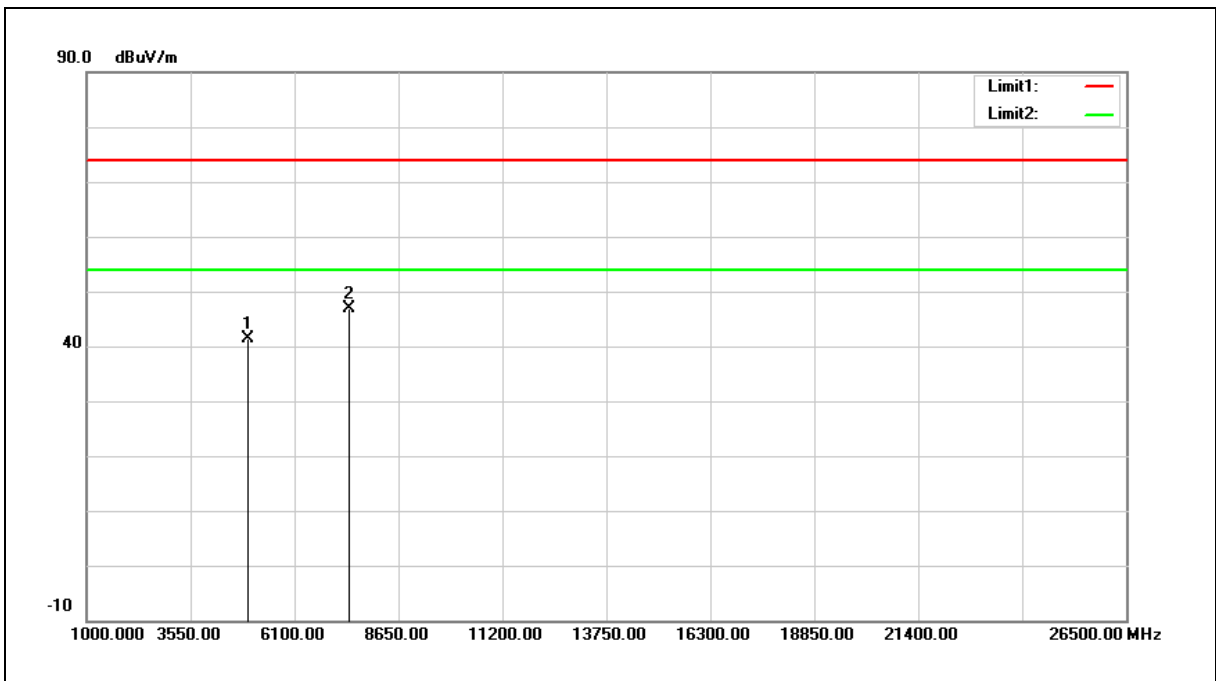

No.	Frequency (MHz)	Reading (dBuV)	Correct Factor (dB/m)	Result (dBuV/m)	Limit (dBuV/m)	Margin (dB)	Remark
1	4960.000	35.08	6.28	41.36	74.00	-32.64	peak
2	7440.000	33.82	13.13	46.95	74.00	-27.05	peak

- Note: 1.Result (dBuV/m) = Correct Factor (dB/m) + Reading(dBuV).
 2.Correction factor (dB/m) = Antenna Factor (dB/m) + Cable loss (dB) – Pre-Amplifier gain (dB).
 3.When the peak results are less than average limit, so not need to evaluate the average.



Band Edge

Standard:	FCC Part 15.247	Test Distance:	3 m
Test item:	Band edge	Power:	AC 120 V/60 Hz
Frequency:	2402 MHz	Temp.(°C)/Hum.(%RH):	25(°C)/60 %RH
Mode:	Mode 2		
Ant.Polar.:	Horizontal		

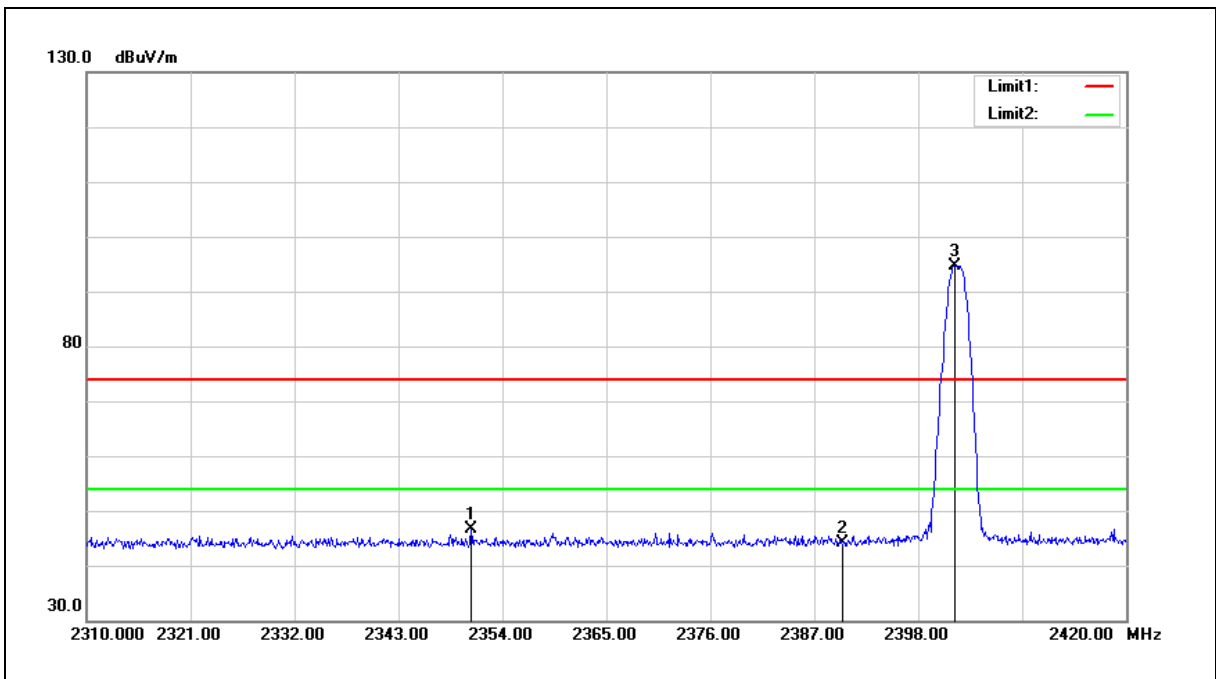

No.	Frequency (MHz)	Reading (dBuV)	Correct Factor (dB/m)	Result (dBuV/m)	Limit (dBuV/m)	Margin (dB)	Remark
1	2350.700	47.62	-1.02	46.60	74.00	-27.40	peak
2	2390.000	44.95	-0.82	44.13	74.00	-29.87	peak
3	2401.850	95.44	-0.76	94.68	--	--	peak

Note:1.Result (dBuV/m) = Correct Factor (dB/m) + Reading(dBuV).

2.Correction factor (dB/m) = Antenna Factor (dB/m) + Cable loss (dB) – Pre-Amplifier gain (dB).

3.When the peak results are less than average limit, so not need to evaluate the average.



Standard:	FCC Part 15.247	Test Distance:	3 m
Test item:	Band edge	Power:	AC 120 V/60 Hz
Frequency:	2402 MHz	Temp.(°C)/Hum.(%RH):	25(°C)/60 %RH
Mode:	Mode 2		
Ant.Polar.:	Vertical		

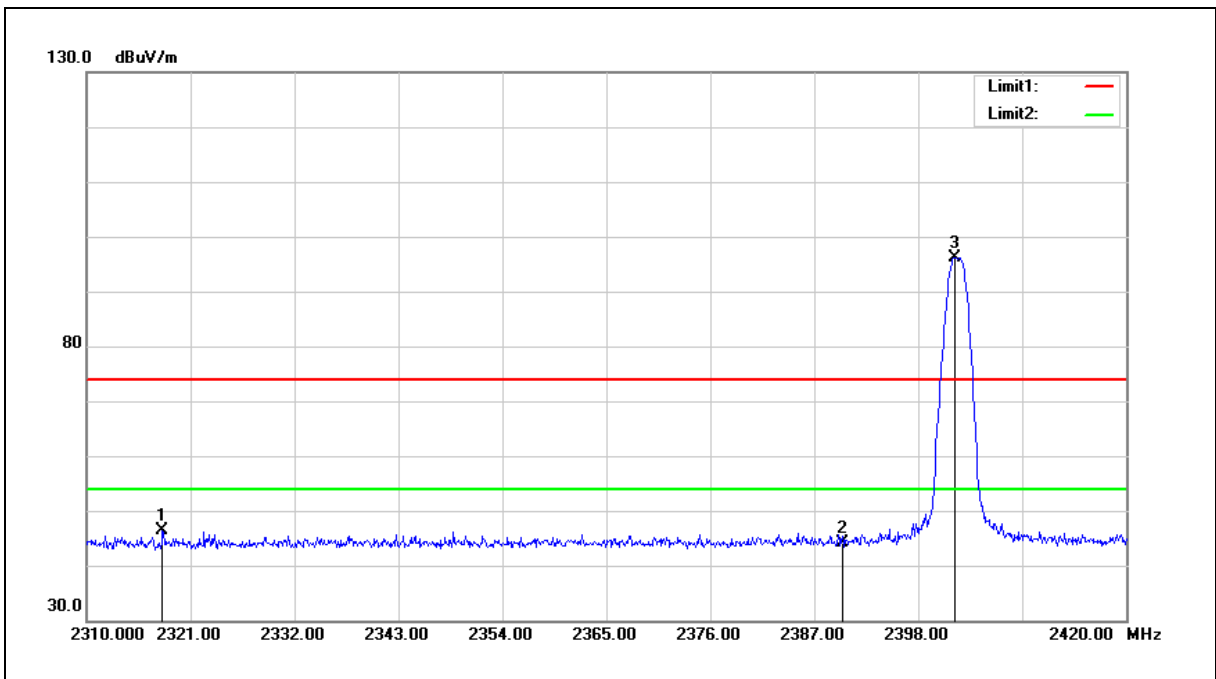

No.	Frequency (MHz)	Reading (dBuV)	Correct Factor (dB/m)	Result (dBuV/m)	Limit (dBuV/m)	Margin (dB)	Remark
1	2318.030	47.50	-1.19	46.31	74.00	-27.69	peak
2	2390.000	44.94	-0.82	44.12	74.00	-29.88	peak
3	2401.850	96.93	-0.76	96.17	--	--	peak

Note:1.Result (dBuV/m) = Correct Factor (dB/m) + Reading(dBuV).

2.Correction factor (dB/m) = Antenna Factor (dB/m) + Cable loss (dB) – Pre-Amplifier gain (dB).

3.When the peak results are less than average limit, so not need to evaluate the average.



Standard:	FCC Part 15.247	Test Distance:	3 m
Test item:	Band edge	Power:	AC 120 V/60 Hz
Frequency:	2480 MHz	Temp.(°C)/Hum.(%RH):	25(°C)/60 %RH
Mode:	Mode 2		
Ant.Polar.:	Horizontal		

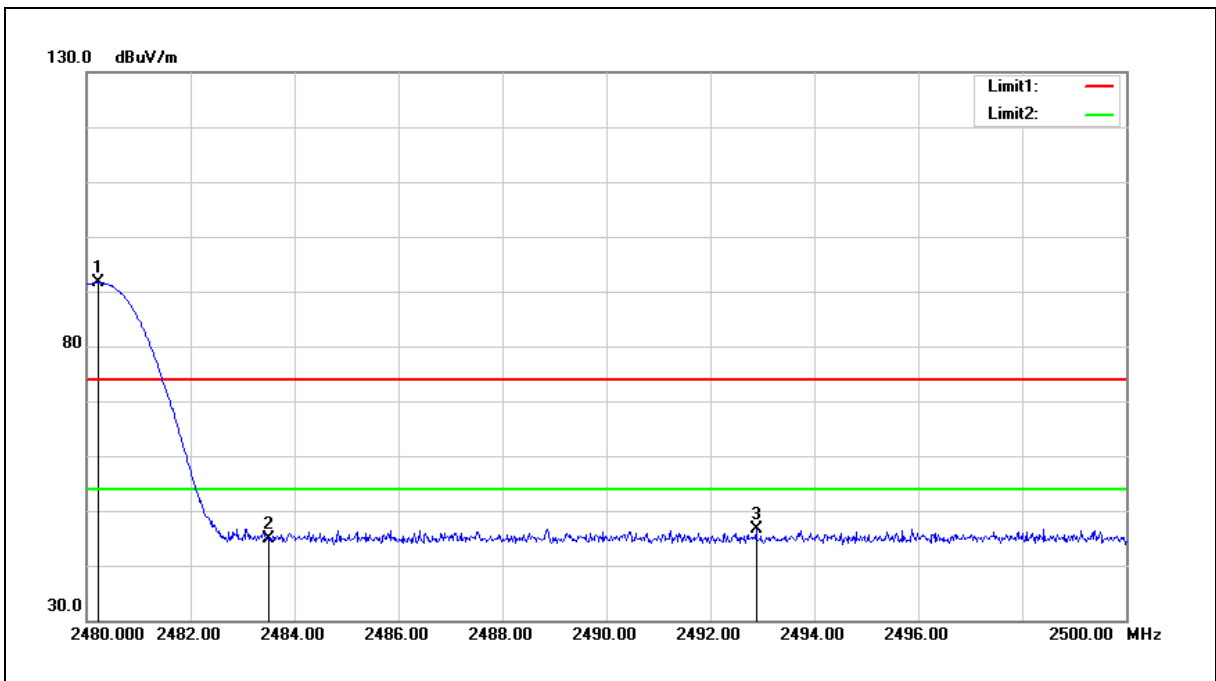

No.	Frequency (MHz)	Reading (dBuV)	Correct Factor (dB/m)	Result (dBuV/m)	Limit (dBuV/m)	Margin (dB)	Remark
1	2480.220	91.97	-0.36	91.61	--	--	peak
2	2483.500	45.30	-0.35	44.95	74.00	-29.05	peak
3	2492.880	47.04	-0.29	46.75	74.00	-27.25	peak

Note:1.Result (dBuV/m) = Correct Factor (dB/m) + Reading(dBuV).

2.Correction factor (dB/m) = Antenna Factor (dB/m) + Cable loss (dB) – Pre-Amplifier gain (dB).

3.When the peak results are less than average limit, so not need to evaluate the average.



Standard:	FCC Part 15.247	Test Distance:	3 m
Test item:	Band edge	Power:	AC 120 V/60 Hz
Frequency:	2480 MHz	Temp.(°C)/Hum.(%RH):	25(°C)/60 %RH
Mode:	Mode 2		
Ant.Polar.:	Vertical		

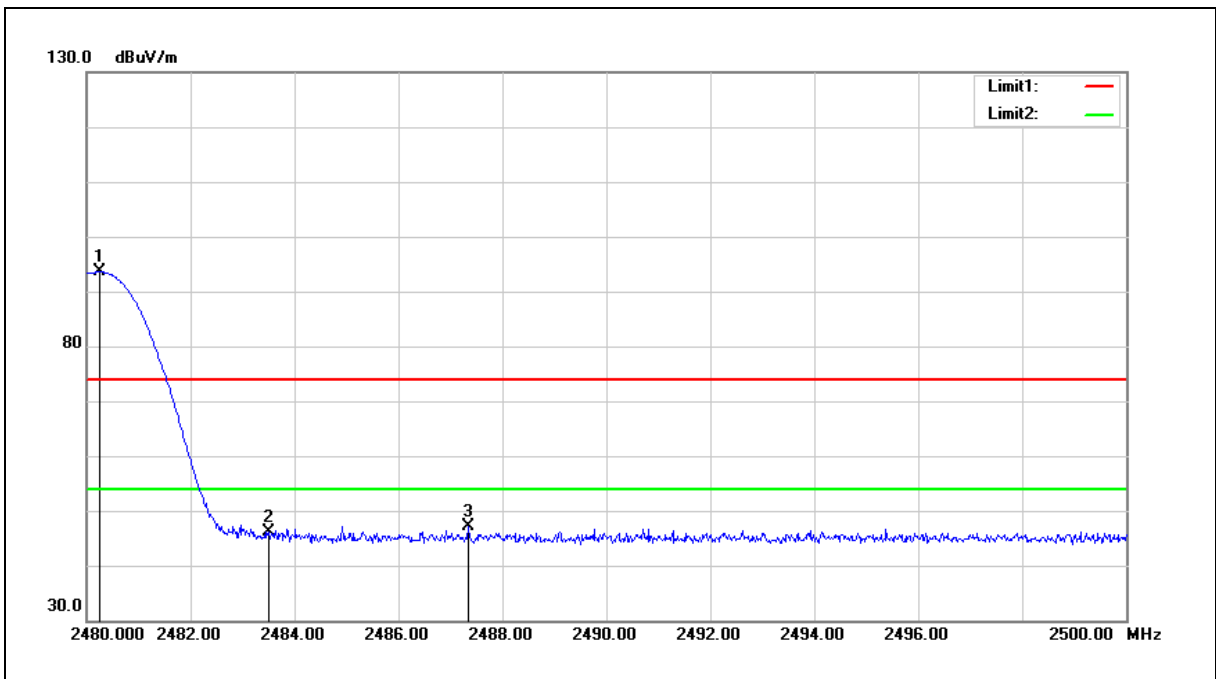

No.	Frequency (MHz)	Reading (dBuV)	Correct Factor (dB/m)	Result (dBuV/m)	Limit (dBuV/m)	Margin (dB)	Remark
1	2480.240	93.95	-0.36	93.59	--	--	peak
2	2483.500	46.41	-0.35	46.06	74.00	-27.94	peak
3	2487.340	47.41	-0.32	47.09	74.00	-26.91	peak

Note:1.Result (dBuV/m) = Correct Factor (dB/m) + Reading(dBuV).

2.Correction factor (dB/m) = Antenna Factor (dB/m) + Cable loss (dB) – Pre-Amplifier gain (dB).

3.When the peak results are less than average limit, so not need to evaluate the average.

--- END---