

Fig.381 Radiated emission: 802.11ac(40M),CH102, 6GHz-18GHz

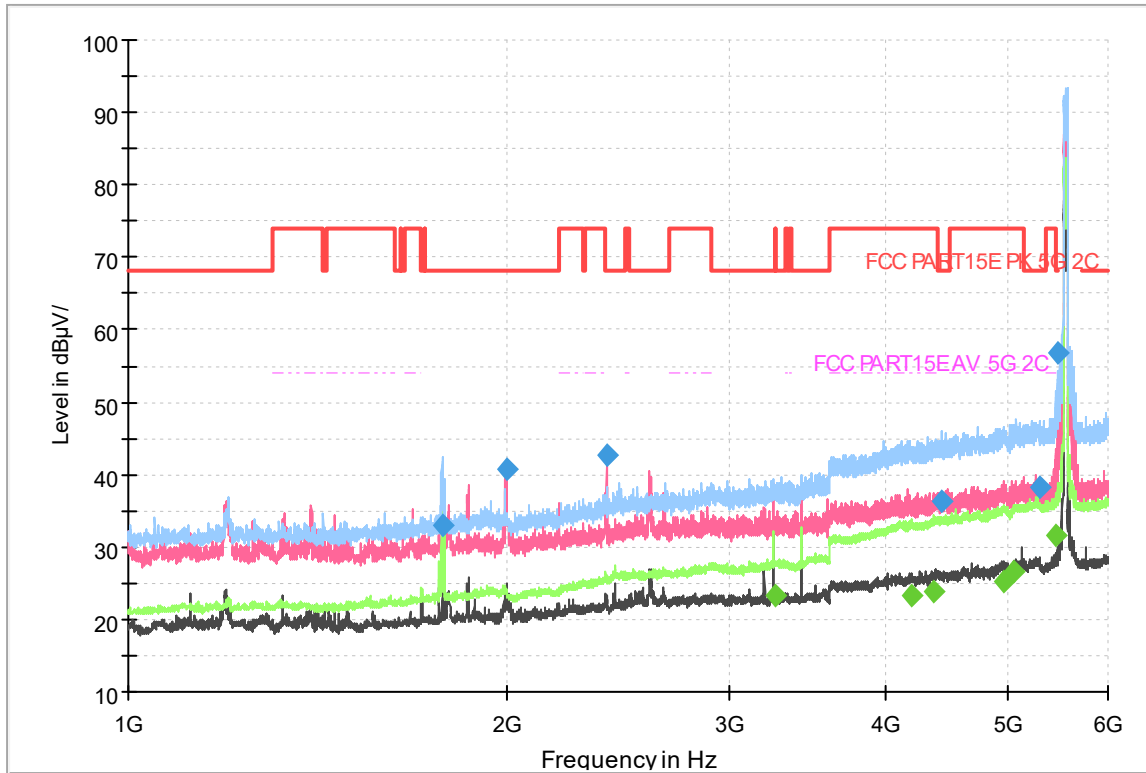

Fig.382 Radiated emission: 802.11ac(40M),CH118, 1GHz-6GHz

Final Result

Frequency (MHz)	MaxPeak (dBµV/m)	Average (dBµV/m)	Limit (dBµV/m)	Margin (dB)	Meas. Time	Bandwidth (kHz)	Height (cm)	Pol	Azimuth (deg)
1775.000000	32.85	---	68.20	35.35	50.0	1000.000	150.0	H	199.0
2000.500000	40.62	---	68.20	27.58	50.0	1000.000	150.0	V	23.0
2396.500000	42.62	---	68.20	25.58	50.0	1000.000	150.0	V	2.0
3265.500000	---	23.29	54.00	30.71	50.0	1000.000	150.0	H	263.0
4189.000000	---	23.16	54.00	30.84	50.0	1000.000	150.0	H	228.0
4364.000000	---	23.73	54.00	30.27	50.0	1000.000	150.0	H	235.0
4421.500000	36.29	---	68.20	31.91	50.0	1000.000	150.0	H	177.0
4965.500000	---	25.32	54.00	28.68	50.0	1000.000	150.0	H	213.0
5048.000000	---	26.74	54.00	27.26	50.0	1000.000	150.0	H	228.0
5296.000000	38.32	---	68.20	29.88	50.0	1000.000	150.0	H	228.0
5458.000000	---	31.68	54.00	22.32	50.0	1000.000	150.0	H	133.0
5469.000000	56.72	---	68.20	11.48	50.0	1000.000	150.0	H	133.0

Chongqing Academy of Information and Communication Technology

Address: No. 8, Yuma Road, Chayuan New City, Nan'an District, Chongqing, P. R. China, 401336
 Tel: 0086-23-88069965 FAX: 0086-23-88608777

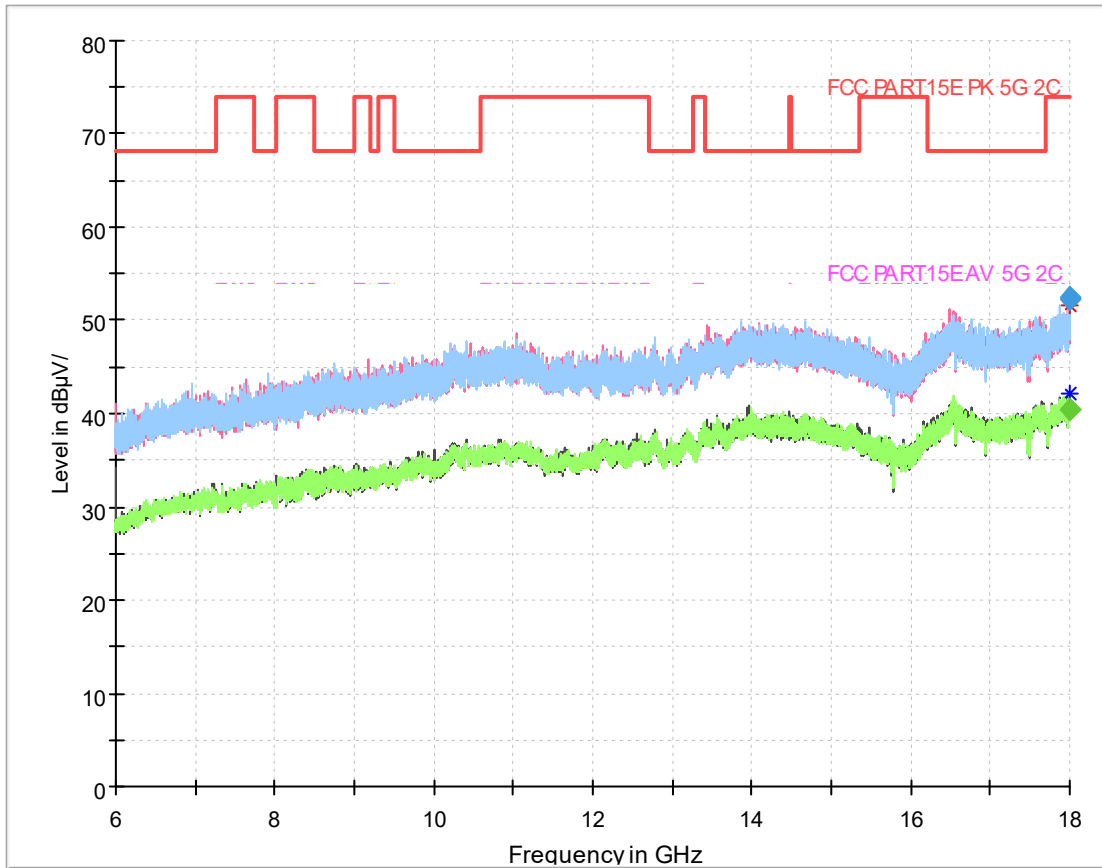

Fig.383 Radiated emission: 802.11ac(40M),CH118, 6GHz-18GHz

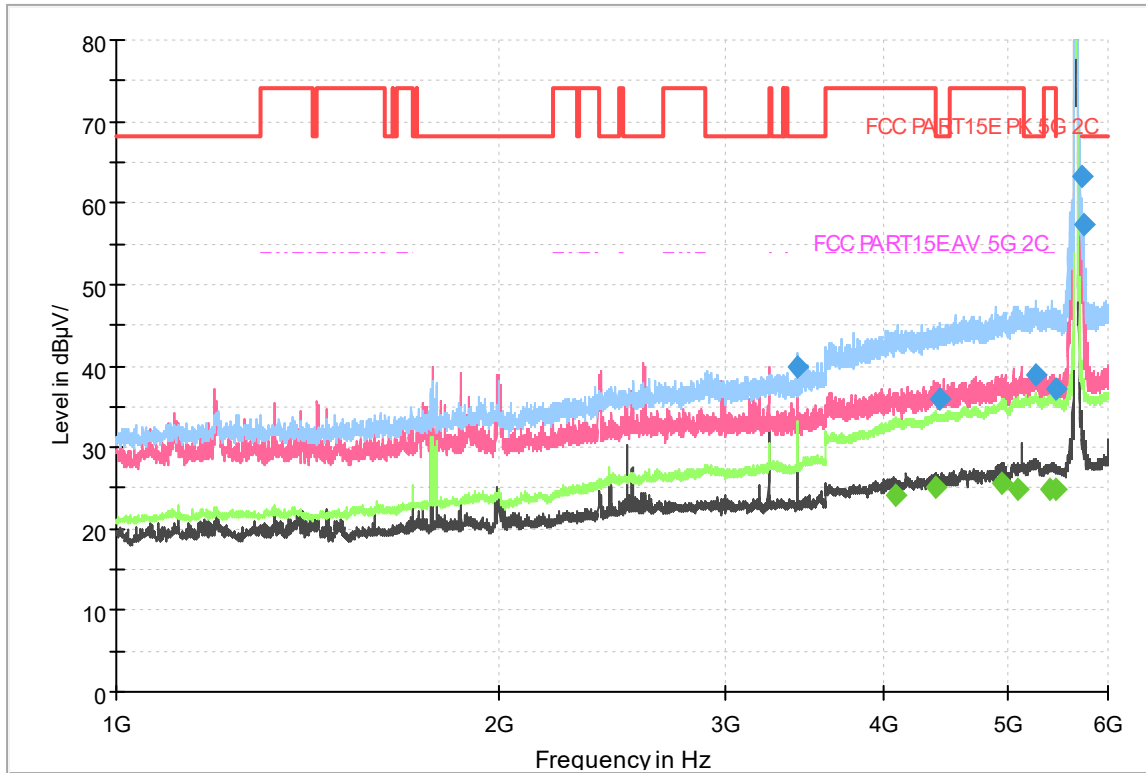

Fig.384 Radiated emission: 802.11ac(40M),CH134, 1GHz-6GHz

Final Result

Frequency (MHz)	MaxPeak (dBµV/m)	Average (dBµV/m)	Limit (dBµV/m)	Margin (dB)	Meas. Time	Bandwidth (kHz)	Height (cm)	Pol	Azimuth (deg)
3422.000000	39.77	---	68.20	28.43	50.0	1000.000	150.0	H	29.0
4088.500000	---	24.17	54.00	29.83	50.0	1000.000	150.0	H	115.0
4394.000000	---	25.11	54.00	28.89	50.0	1000.000	150.0	H	50.0
4434.000000	35.87	---	68.20	32.33	50.0	1000.000	150.0	H	72.0
4958.000000	---	25.53	54.00	28.47	50.0	1000.000	150.0	H	22.0
5092.000000	---	24.94	54.00	29.06	50.0	1000.000	150.0	H	161.0
5265.500000	38.84	---	68.20	29.36	50.0	1000.000	150.0	H	79.0
5398.000000	---	24.98	54.00	29.02	50.0	1000.000	150.0	H	122.0
5460.000000	37.24	---	68.20	30.96	50.0	1000.000	150.0	H	122.0
5460.000000	---	24.94	54.00	29.06	50.0	1000.000	150.0	H	122.0
5728.500000	63.22	---	68.20	4.98	50.0	1000.000	150.0	H	161.0
5742.500000	57.28	---	68.20	10.92	50.0	1000.000	150.0	H	36.0

Chongqing Academy of Information and Communication Technology

Address: No. 8, Yuma Road, Chayuan New City, Nan'an District, Chongqing, P. R. China, 401336
 Tel: 0086-23-88069965 FAX: 0086-23-88608777

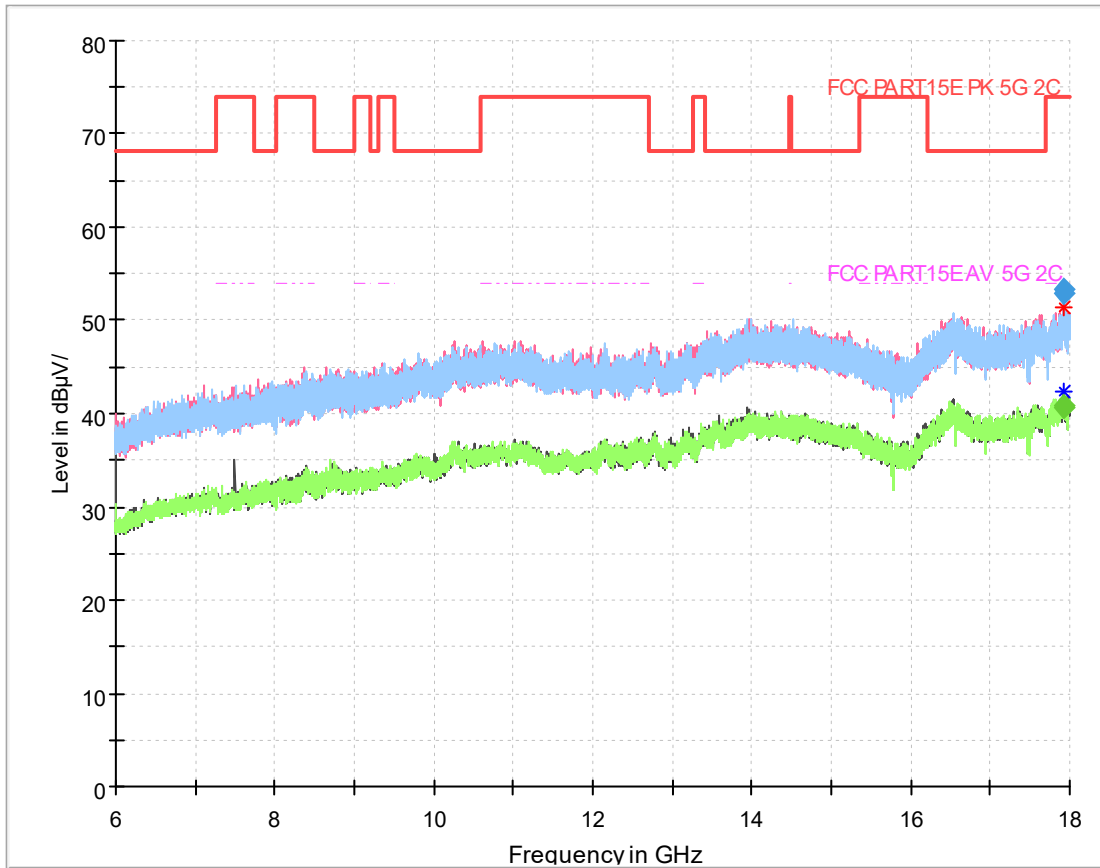

Fig.385 Radiated emission: 802.11ac(40M),CH134, 6GHz-18GHz

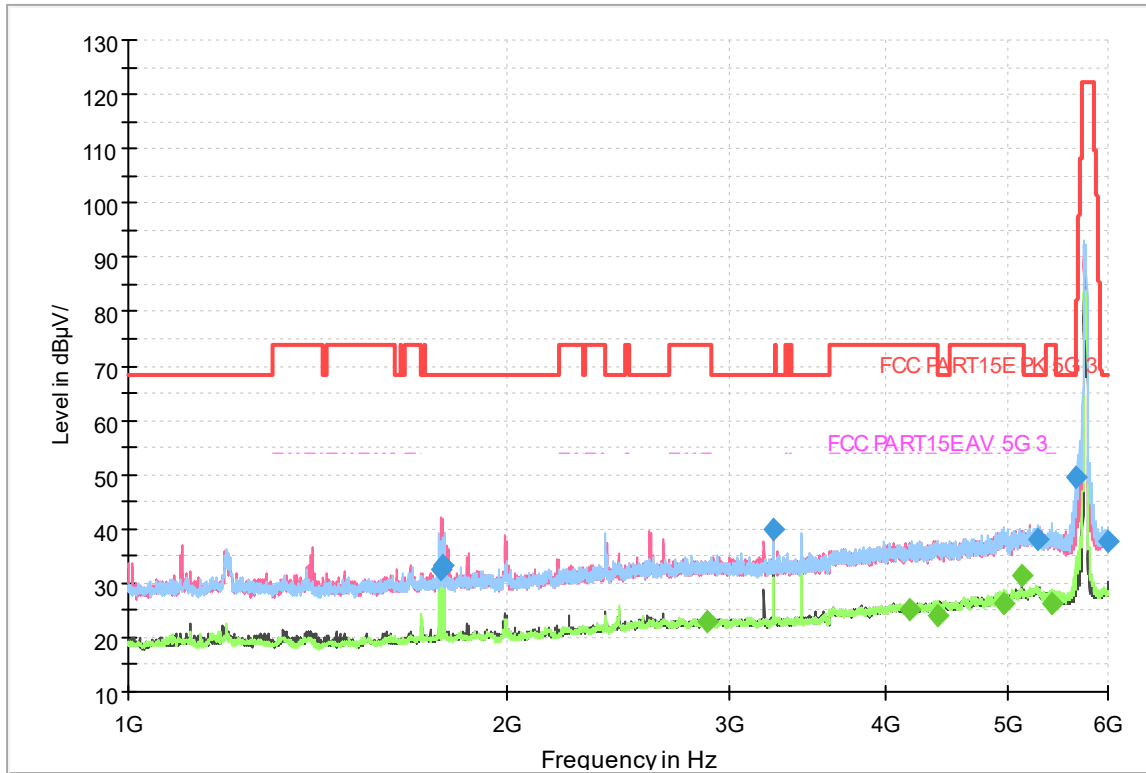

Fig.386 Radiated emission: 802.11ac(40M),CH151, 1GHz-6GHz

Final Result

Frequency (MHz)	MaxPeak (dBµV/m)	Average (dBµV/m)	Limit (dBµV/m)	Margin (dB)	Meas. Time	Bandwidth (kHz)	Height (cm)	Pol	Azimuth (deg)
1774.000000	32.61	---	68.20	35.59	50.0	1000.000	150.0	V	139.0
1779.000000	33.38	---	68.20	34.82	50.0	1000.000	150.0	V	204.0
2880.000000	---	22.78	54.00	31.22	50.0	1000.000	150.0	V	66.0
3251.000000	40.09	---	68.20	28.11	50.0	1000.000	150.0	V	132.0
4173.000000	---	25.13	54.00	28.87	50.0	1000.000	150.0	H	239.0
4396.000000	---	24.20	54.00	29.80	50.0	1000.000	150.0	H	96.0
4967.500000	---	26.39	54.00	27.61	50.0	1000.000	150.0	H	132.0
5132.500000	---	31.27	54.00	22.73	50.0	1000.000	150.0	V	102.0
5286.000000	37.89	---	68.20	30.31	50.0	1000.000	150.0	H	253.0
5421.000000	---	26.20	54.00	27.80	50.0	1000.000	150.0	H	96.0
5650.000000	49.59	---	68.20	18.61	50.0	1000.000	150.0	H	175.0
5993.500000	37.57	---	68.20	30.63	50.0	1000.000	150.0	H	239.0

Chongqing Academy of Information and Communication Technology

Address: No. 8, Yuma Road, Chayuan New City, Nan'an District, Chongqing, P. R. China, 401336
 Tel: 0086-23-88069965 FAX: 0086-23-88608777

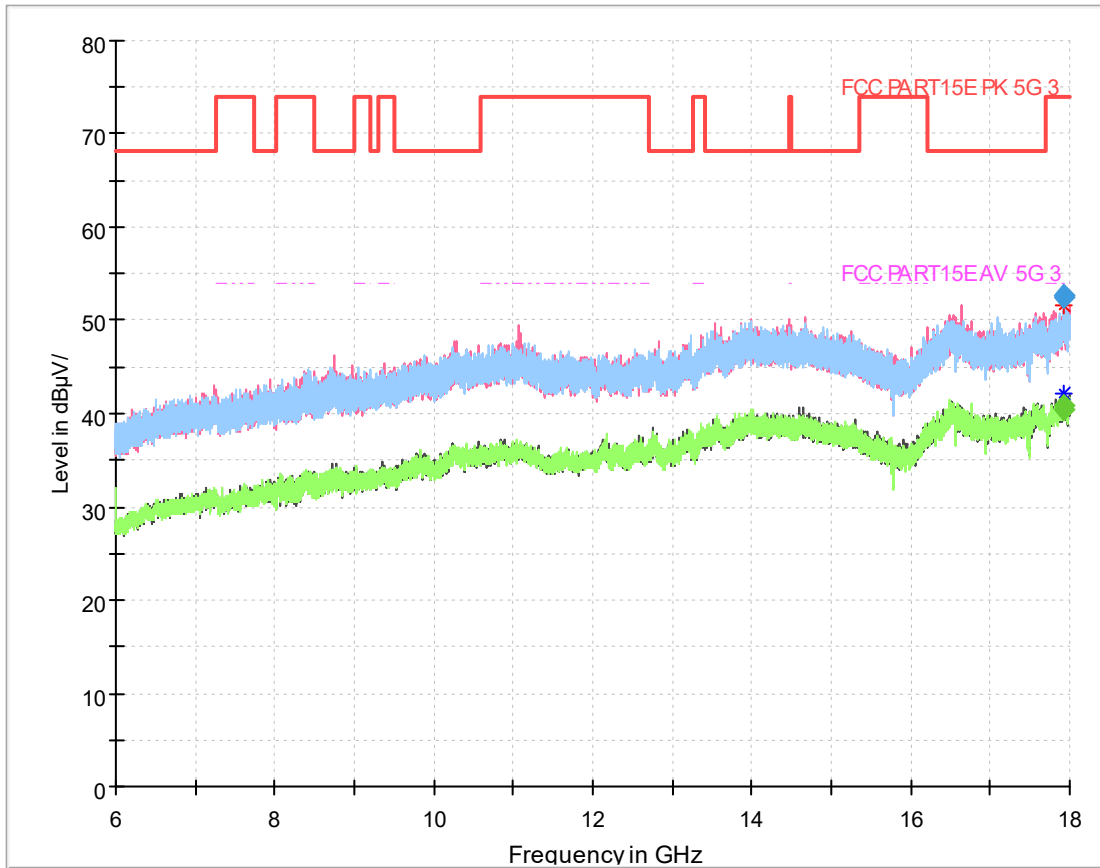

Fig.387 Radiated emission: 802.11ac(40M),CH151, 6GHz-18GHz

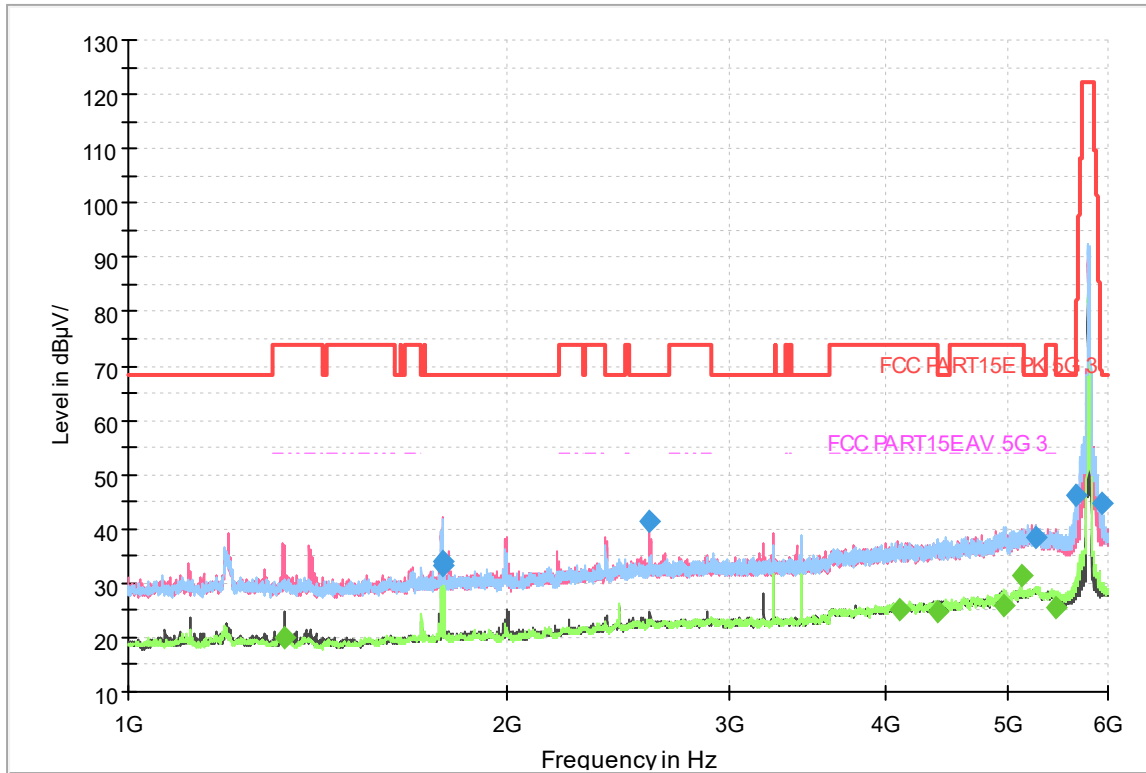

Fig.388 Radiated emission: 802.11ac(40M),CH159, 1GHz-6GHz

Final Result

Frequency (MHz)	MaxPeak (dBµV/m)	Average (dBµV/m)	Limit (dBµV/m)	Margin (dB)	Meas. Time	Bandwidth (kHz)	Height (cm)	Pol	Azimuth (deg)
1330.000000	---	20.06	54.00	33.94	50.0	1000.000	150.0	V	23.0
1775.500000	33.25	---	68.20	34.95	50.0	1000.000	150.0	V	211.0
1777.000000	33.95	---	68.20	34.25	50.0	1000.000	150.0	H	81.0
2589.000000	41.42	---	68.20	26.78	50.0	1000.000	150.0	V	0.0
4105.500000	---	25.31	54.00	28.69	50.0	1000.000	150.0	H	45.0
4391.000000	---	24.72	54.00	29.28	50.0	1000.000	150.0	H	218.0
4954.000000	---	25.78	54.00	28.22	50.0	1000.000	150.0	H	240.0
5132.500000	---	31.28	54.00	22.72	50.0	1000.000	150.0	V	102.0
5256.500000	38.30	---	68.20	29.90	50.0	1000.000	150.0	V	23.0
5454.000000	---	25.54	54.00	28.46	50.0	1000.000	150.0	H	124.0
5648.000000	46.17	---	68.20	22.03	50.0	1000.000	150.0	H	146.0
5931.500000	44.74	---	68.20	23.46	50.0	1000.000	150.0	H	139.0

Chongqing Academy of Information and Communication Technology

Address: No. 8, Yuma Road, Chayuan New City, Nan'an District, Chongqing, P. R. China, 401336
 Tel: 0086-23-88069965 FAX: 0086-23-88608777

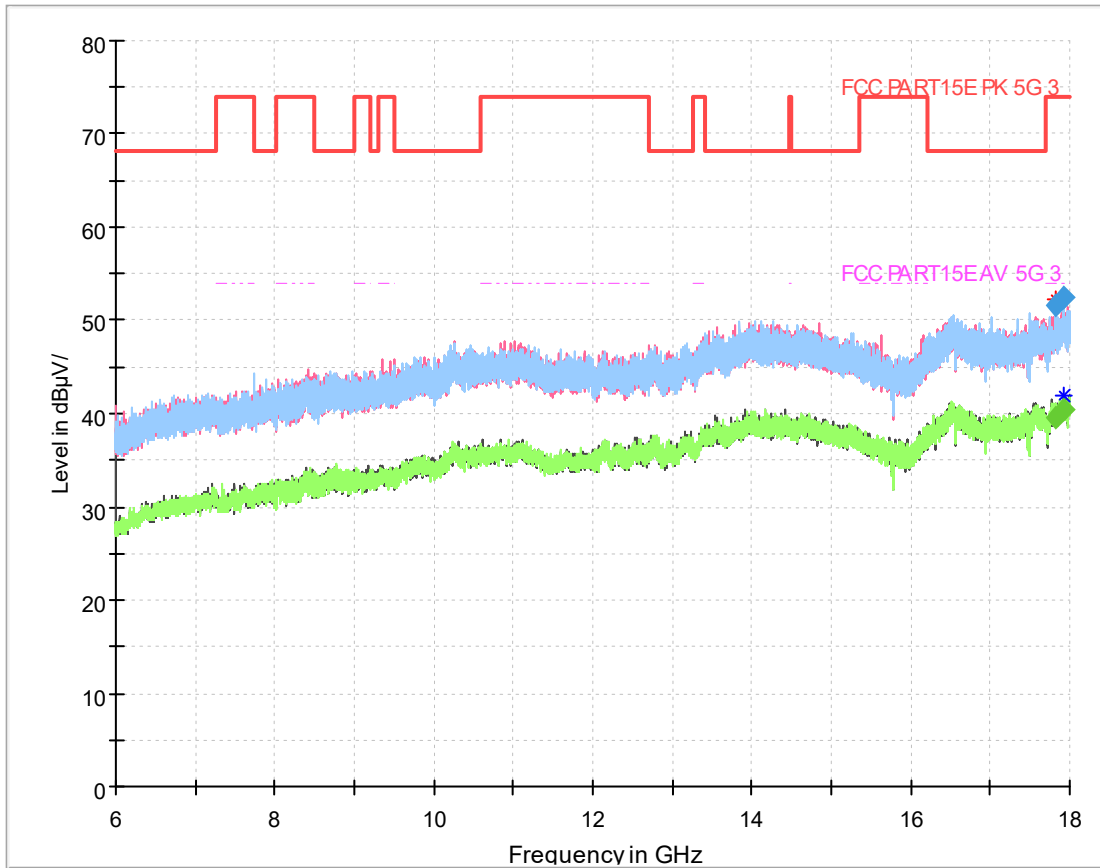

Fig.389 Radiated emission: 802.11ac(40M),CH159, 6GHz-18GHz

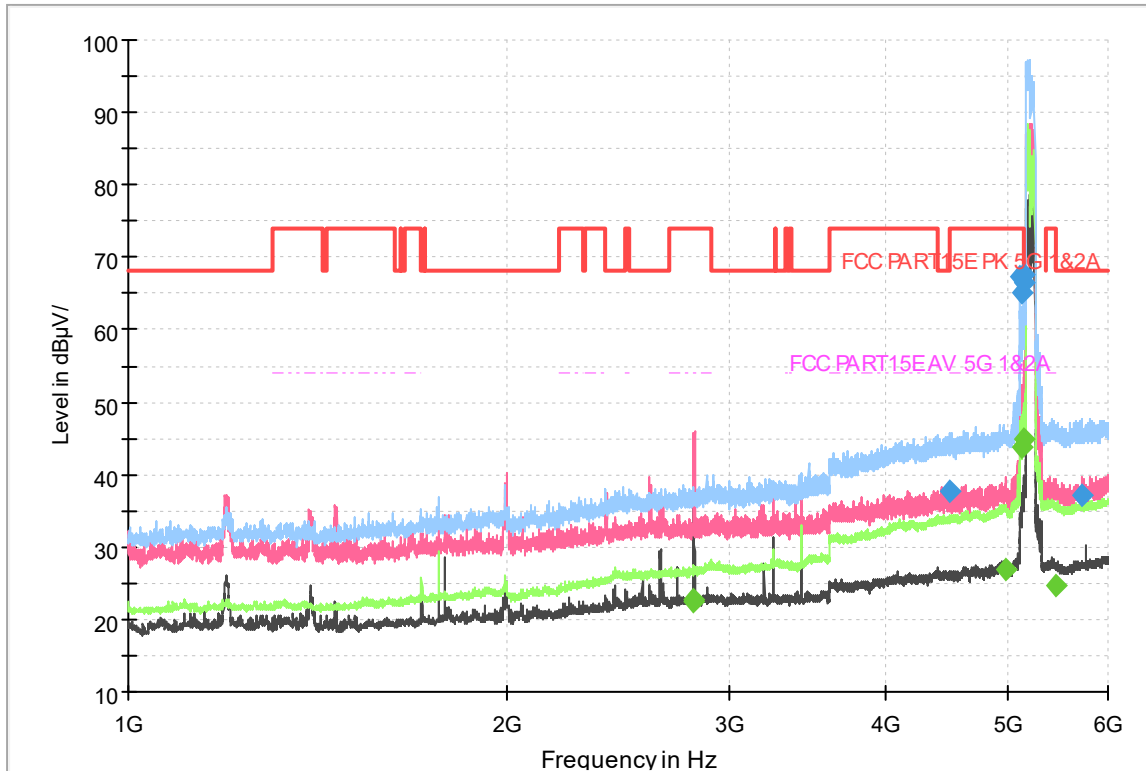

Fig.390 Radiated emission: 802.11ac(80M),CH42, 1GHz-6GHz

Final Result

Frequency (MHz)	MaxPeak (dBµV/m)	Average (dBµV/m)	Limit (dBµV/m)	Margin (dB)	Meas. Time	Bandwidth (kHz)	Height (cm)	Pol	Azimuth (deg)
2812.500000	---	22.52	54.00	31.48	50.0	1000.000	150.0	V	17.0
2814.500000	---	22.79	54.00	31.21	50.0	1000.000	150.0	V	17.0
4491.500000	37.65	---	68.20	30.55	50.0	1000.000	150.0	H	171.0
4974.000000	---	26.82	54.00	27.18	50.0	1000.000	150.0	H	199.0
5113.000000	67.25	---	74.00	6.75	50.0	1000.000	150.0	H	156.0
5120.000000	65.18	---	74.00	8.82	50.0	1000.000	150.0	H	156.0
5123.000000	---	43.76	54.00	10.24	50.0	1000.000	150.0	H	156.0
5145.500000	67.53	---	74.00	6.47	50.0	1000.000	150.0	H	156.0
5145.500000	---	45.00	54.00	9.00	50.0	1000.000	150.0	H	156.0
5150.000000	66.40	---	68.20	1.80	50.0	1000.000	150.0	H	156.0
5450.500000	---	24.68	54.00	29.32	50.0	1000.000	150.0	H	263.0
5726.000000	37.01	---	68.20	31.19	50.0	1000.000	150.0	H	242.0

Chongqing Academy of Information and Communication Technology

Address: No. 8, Yuma Road, Chayuan New City, Nan'an District, Chongqing, P. R. China, 401336
 Tel: 0086-23-88069965 FAX: 0086-23-88608777

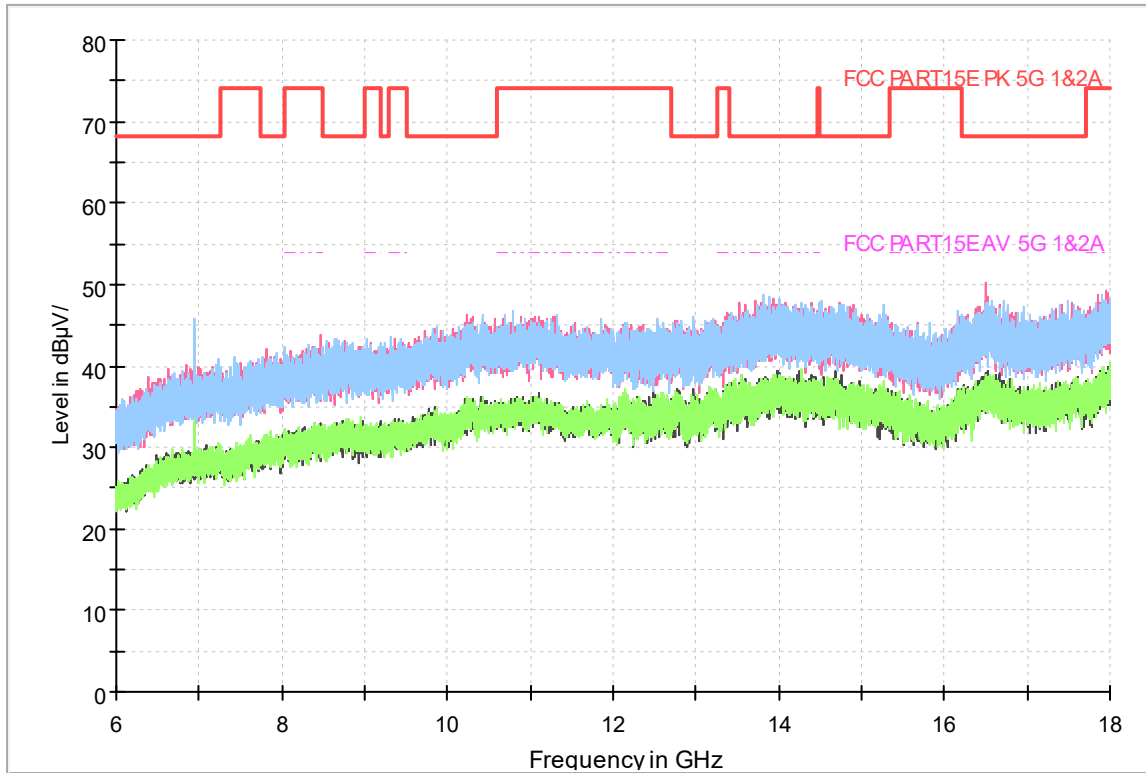

Fig.391 Radiated emission: 802.11ac(80M),CH42, 6GHz-18GHz

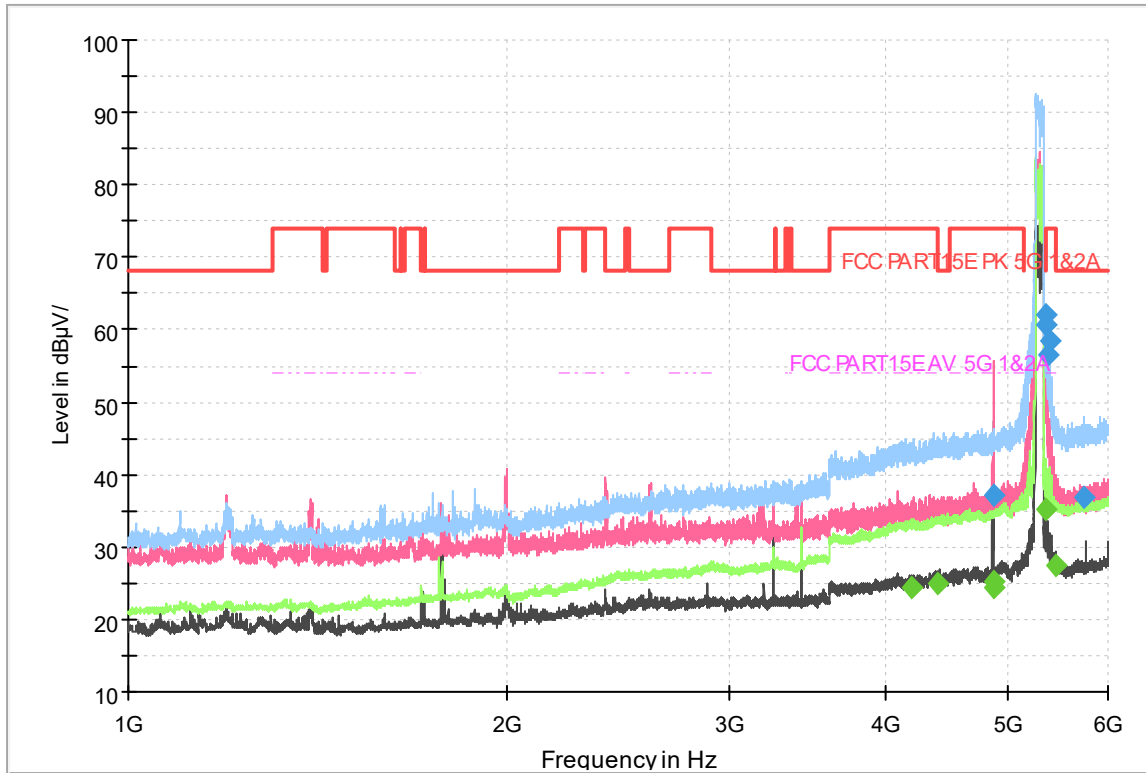

Fig.392 Radiated emission: 802.11ac(80M),CH58, 1GHz-6GHz

Final Result

Frequency (MHz)	MaxPeak (dBµV/m)	Average (dBµV/m)	Limit (dBµV/m)	Margin (dB)	Meas. Time	Bandwidth (kHz)	Height (cm)	Pol	Azimuth (deg)
4185.000000	---	24.32	54.00	29.68	50.0	1000.000	150.0	H	264.0
4395.000000	---	24.85	54.00	29.15	50.0	1000.000	150.0	H	242.0
4861.000000	---	25.13	54.00	28.87	50.0	1000.000	150.0	V	138.0
4864.000000	37.13	---	74.00	36.87	50.0	1000.000	150.0	V	138.0
4864.000000	---	24.51	54.00	29.49	50.0	1000.000	150.0	V	138.0
5351.000000	62.00	---	74.00	12.00	50.0	1000.000	150.0	H	205.0
5357.500000	---	35.24	54.00	18.76	50.0	1000.000	150.0	H	111.0
5365.500000	60.74	---	74.00	13.26	50.0	1000.000	150.0	H	111.0
5377.000000	56.65	---	74.00	17.35	50.0	1000.000	150.0	H	168.0
5391.500000	58.44	---	74.00	15.56	50.0	1000.000	150.0	H	111.0
5458.000000	---	27.48	54.00	26.52	50.0	1000.000	150.0	H	183.0
5732.500000	36.96	---	68.20	31.24	50.0	1000.000	150.0	H	220.0

Chongqing Academy of Information and Communication Technology

Address: No. 8, Yuma Road, Chayuan New City, Nan'an District, Chongqing, P. R. China, 401336
 Tel: 0086-23-88069965 FAX: 0086-23-88608777

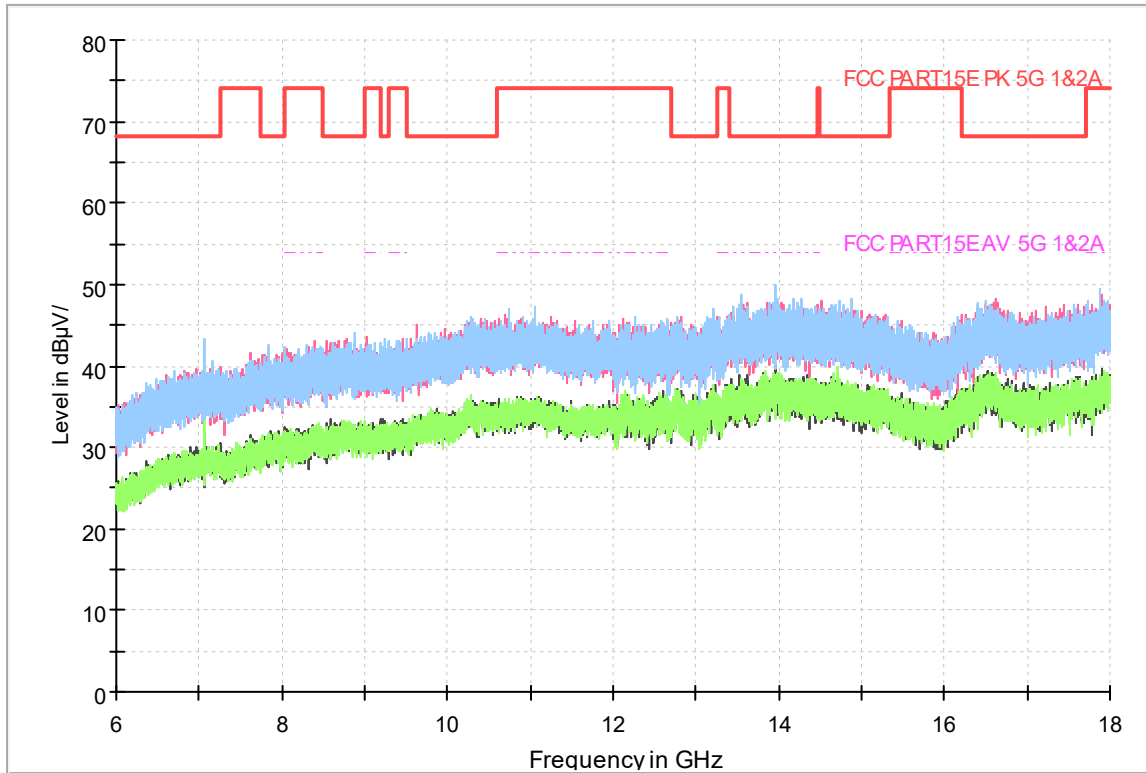

Fig.393 Radiated emission: 802.11ac(80M),CH58, 6GHz-18GHz

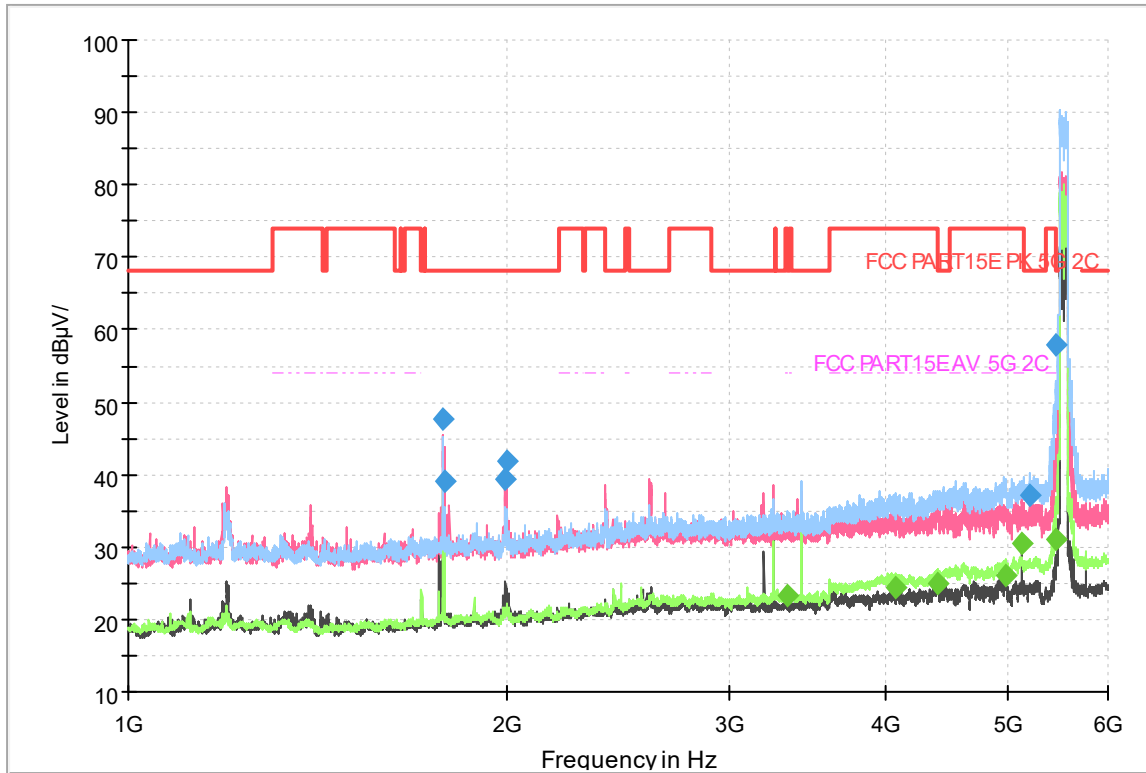

Fig.394 Radiated emission: 802.11ac(80M),CH106, 1GHz-6GHz

Final Result

Frequency (MHz)	MaxPeak (dBµV/m)	Average (dBµV/m)	Limit (dBµV/m)	Margin (dB)	Meas. Time	Bandwidth (kHz)	Height (cm)	Pol	Azimuth (deg)
1777.000000	47.57	---	68.20	20.63	50.0	1000.000	150.0	V	189.0
1783.500000	39.14	---	68.20	29.06	50.0	1000.000	150.0	V	125.0
1990.500000	39.26	---	68.20	28.94	50.0	1000.000	150.0	V	211.0
1995.500000	41.74	---	68.20	26.46	50.0	1000.000	150.0	V	2.0
3336.500000	---	23.20	54.00	30.80	50.0	1000.000	150.0	H	177.0
4062.000000	---	24.37	54.00	29.63	50.0	1000.000	150.0	H	227.0
4387.500000	---	24.83	54.00	29.17	50.0	1000.000	150.0	H	219.0
4984.500000	---	26.15	54.00	27.85	50.0	1000.000	150.0	H	177.0
5132.500000	---	30.52	54.00	23.48	50.0	1000.000	150.0	V	102.0
5207.500000	37.10	---	68.20	31.10	50.0	1000.000	150.0	H	257.0
5452.500000	---	31.01	54.00	22.99	50.0	1000.000	150.0	H	198.0
5461.000000	57.91	---	68.20	10.29	50.0	1000.000	150.0	H	212.0

Chongqing Academy of Information and Communication Technology

Address: No. 8, Yuma Road, Chayuan New City, Nan'an District, Chongqing, P. R. China, 401336
 Tel: 0086-23-88069965 FAX: 0086-23-88608777

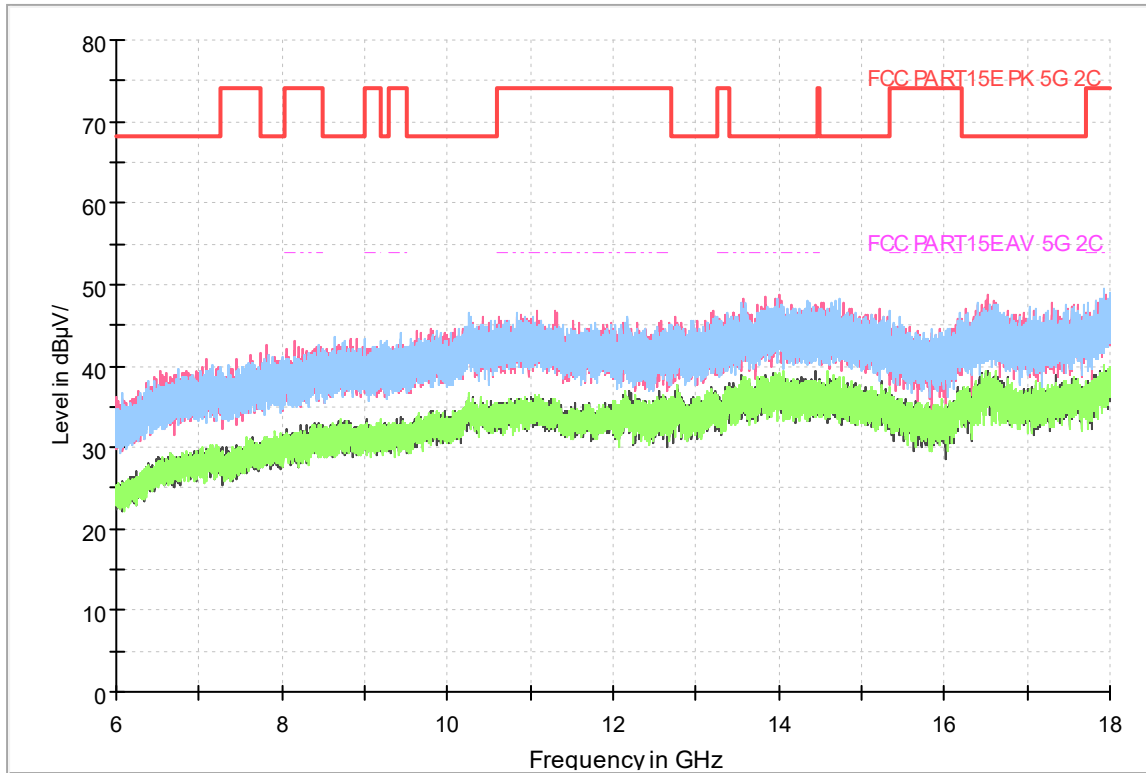

Fig.395 Radiated emission: 802.11ac(80M),CH106, 6GHz-18GHz

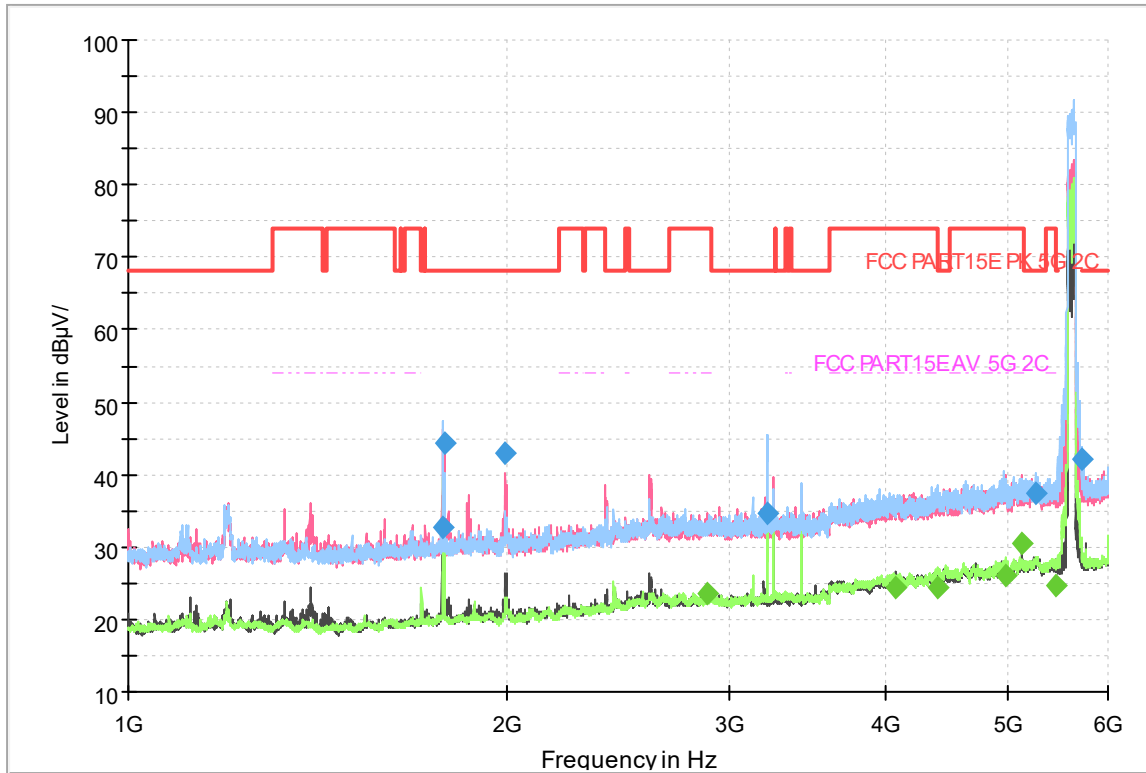

Fig.396 Radiated emission: 802.11ac(80M),CH122, 1GHz-6GHz

Final Result

Frequency (MHz)	MaxPeak (dBµV/m)	Average (dBµV/m)	Limit (dBµV/m)	Margin (dB)	Meas. Time	Bandwidth (kHz)	Height (cm)	Pol	Azimuth (deg)
1776.000000	32.79	---	68.20	35.41	50.0	1000.000	150.0	H	84.0
1784.000000	44.36	---	68.20	23.84	50.0	1000.000	150.0	V	17.0
1995.000000	42.97	---	68.20	25.23	50.0	1000.000	150.0	V	195.0
2880.000000	---	23.54	54.00	30.46	50.0	1000.000	150.0	V	17.0
3219.000000	34.67	---	68.20	33.53	50.0	1000.000	150.0	H	18.0
4076.000000	---	24.50	54.00	29.50	50.0	1000.000	150.0	V	123.0
4391.500000	---	24.49	54.00	29.51	50.0	1000.000	150.0	H	269.0
4978.500000	---	26.19	54.00	27.81	50.0	1000.000	150.0	H	105.0
5132.000000	---	30.43	54.00	23.57	50.0	1000.000	150.0	V	104.0
5265.000000	37.54	---	68.20	30.66	50.0	1000.000	150.0	H	198.0
5447.500000	---	24.62	54.00	29.38	50.0	1000.000	150.0	V	53.0
5725.500000	42.14	---	68.20	26.06	50.0	1000.000	150.0	H	191.0

Chongqing Academy of Information and Communication Technology

Address: No. 8, Yuma Road, Chayuan New City, Nan'an District, Chongqing, P. R. China, 401336
 Tel: 0086-23-88069965 FAX: 0086-23-88608777

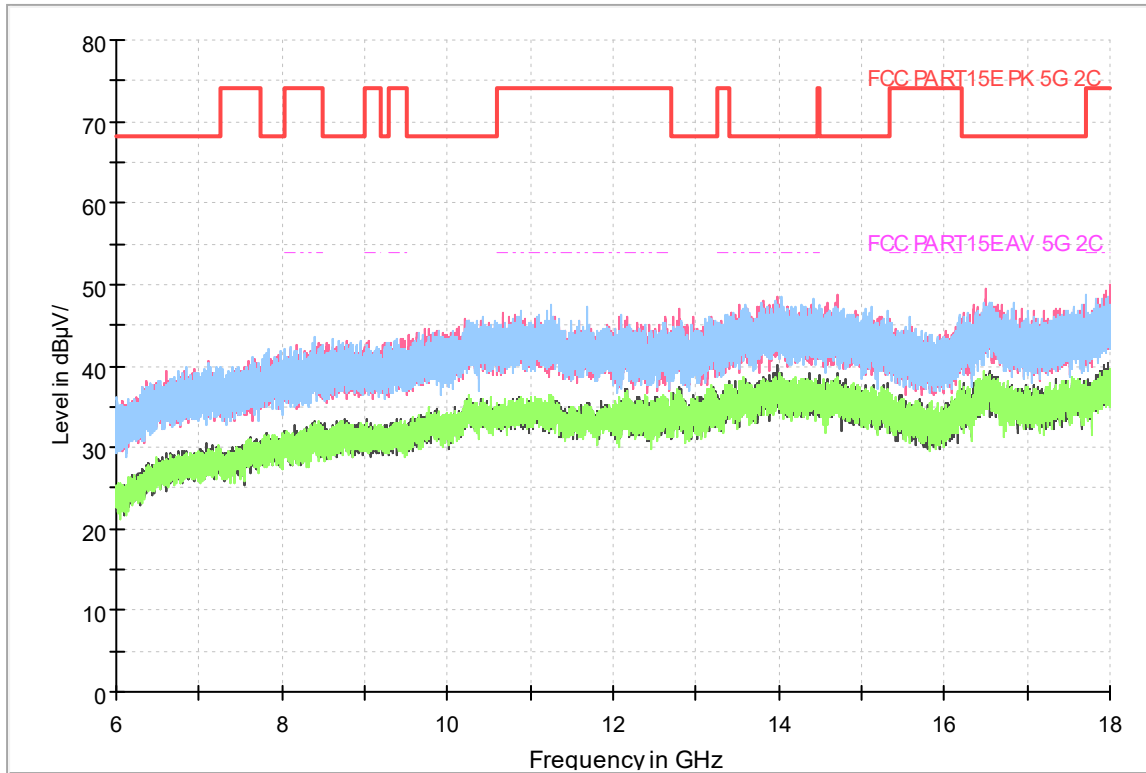

Fig.397 Radiated emission: 802.11ac(80M),CH122, 6GHz-18GHz

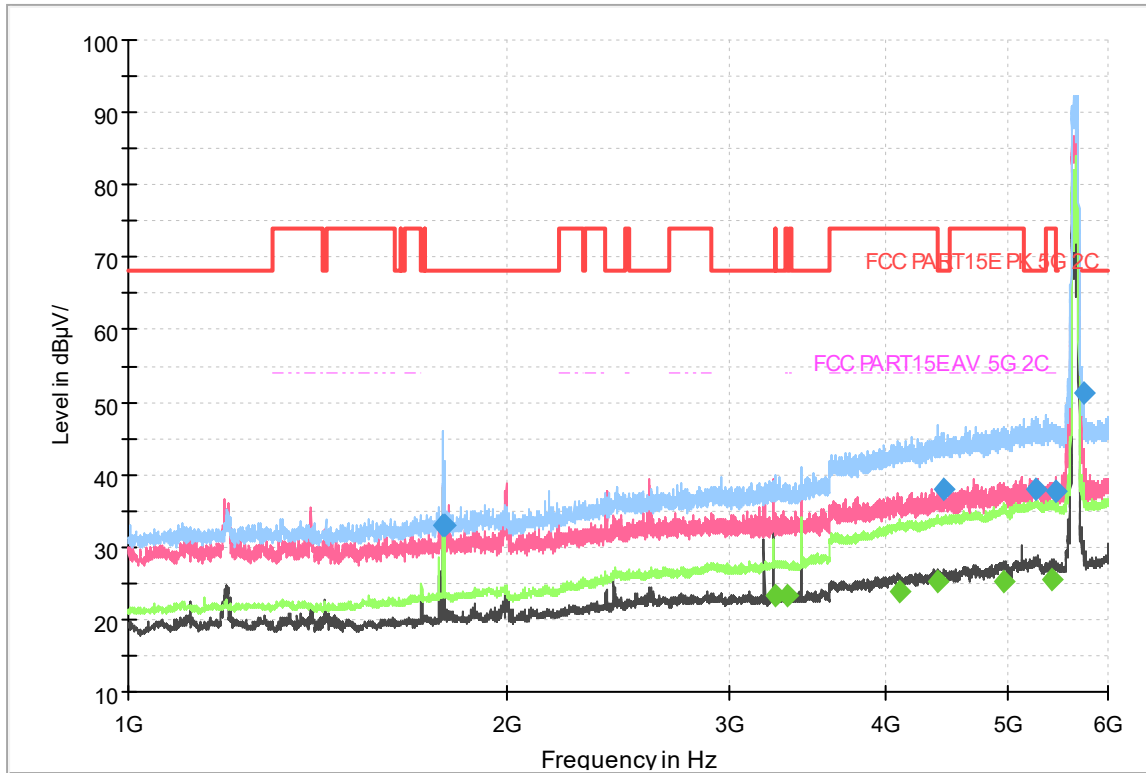

Fig.398 Radiated emission: 802.11ac(80M),CH130, 1GHz-6GHz

Final Result

Frequency (MHz)	MaxPeak (dBµV/m)	Average (dBµV/m)	Limit (dBµV/m)	Margin (dB)	Meas. Time	Bandwidth (kHz)	Height (cm)	Pol	Azimuth (deg)
1775.500000	32.99	---	68.20	35.21	50.0	1000.000	150.0	H	7.0
1784.000000	33.05	---	68.20	35.15	50.0	1000.000	150.0	H	147.0
3265.500000	---	23.21	54.00	30.79	50.0	1000.000	150.0	H	1.0
3336.000000	---	23.16	54.00	30.84	50.0	1000.000	150.0	H	36.0
4095.500000	---	23.86	54.00	30.14	50.0	1000.000	150.0	H	1.0
4386.500000	---	25.20	54.00	28.80	50.0	1000.000	150.0	H	29.0
4446.500000	38.02	---	68.20	30.18	50.0	1000.000	150.0	H	15.0
4964.500000	---	25.19	54.00	28.81	50.0	1000.000	150.0	H	58.0
5264.000000	38.01	---	68.20	30.19	50.0	1000.000	150.0	H	131.0
5419.000000	---	25.54	54.00	28.46	50.0	1000.000	150.0	H	87.0
5462.000000	37.71	---	68.20	30.49	50.0	1000.000	150.0	H	22.0
5735.000000	51.26	---	68.20	16.94	50.0	1000.000	150.0	H	65.0

Chongqing Academy of Information and Communication Technology

Address: No. 8, Yuma Road, Chayuan New City, Nan'an District, Chongqing, P. R. China, 401336
 Tel: 0086-23-88069965 FAX: 0086-23-88608777

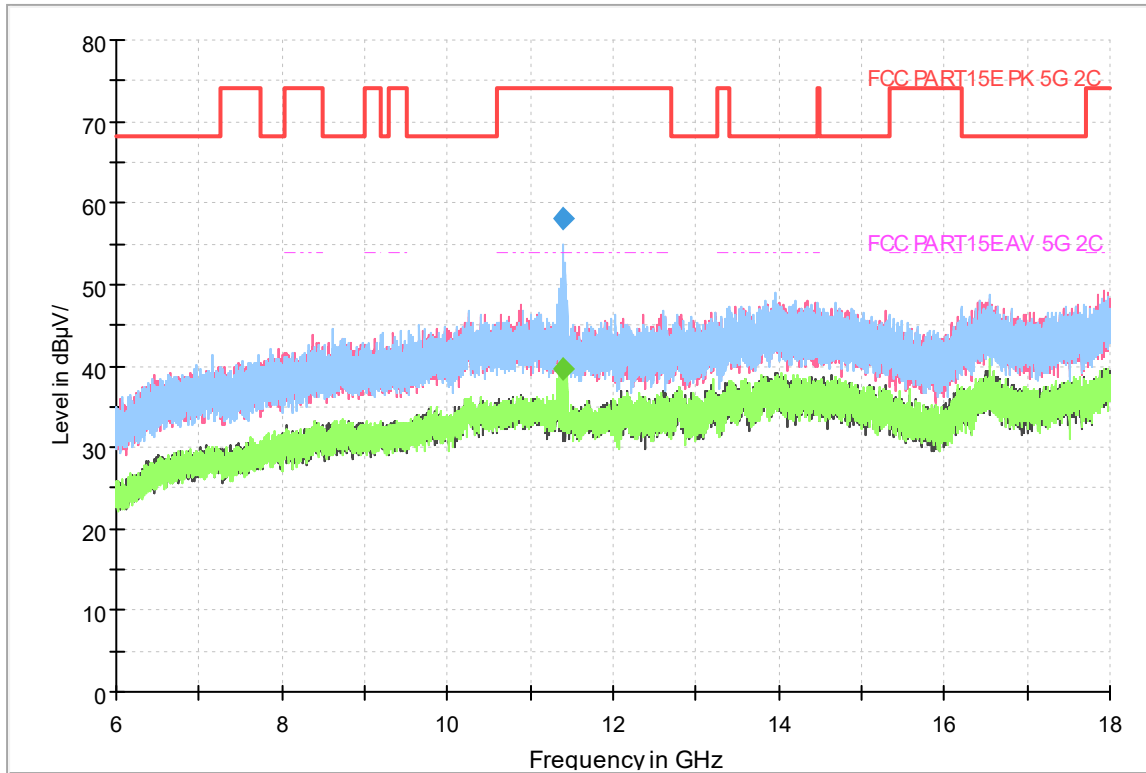

Fig.399 Radiated emission: 802.11ac(80M),CH130, 6GHz-18GHz

Final Result

Frequency (MHz)	MaxPeak (dBµV/m)	Average (dBµV/m)	Limit (dBµV/m)	Margin (dB)	Meas. Time	Bandwidth (kHz)	Height (cm)	Pol	Azimuth (deg)
11397.600000	58.04	---	74.00	15.96	50.0	1000.000	170.0	H	0.0
11401.500000	---	39.70	54.00	14.30	50.0	1000.000	170.0	H	0.0

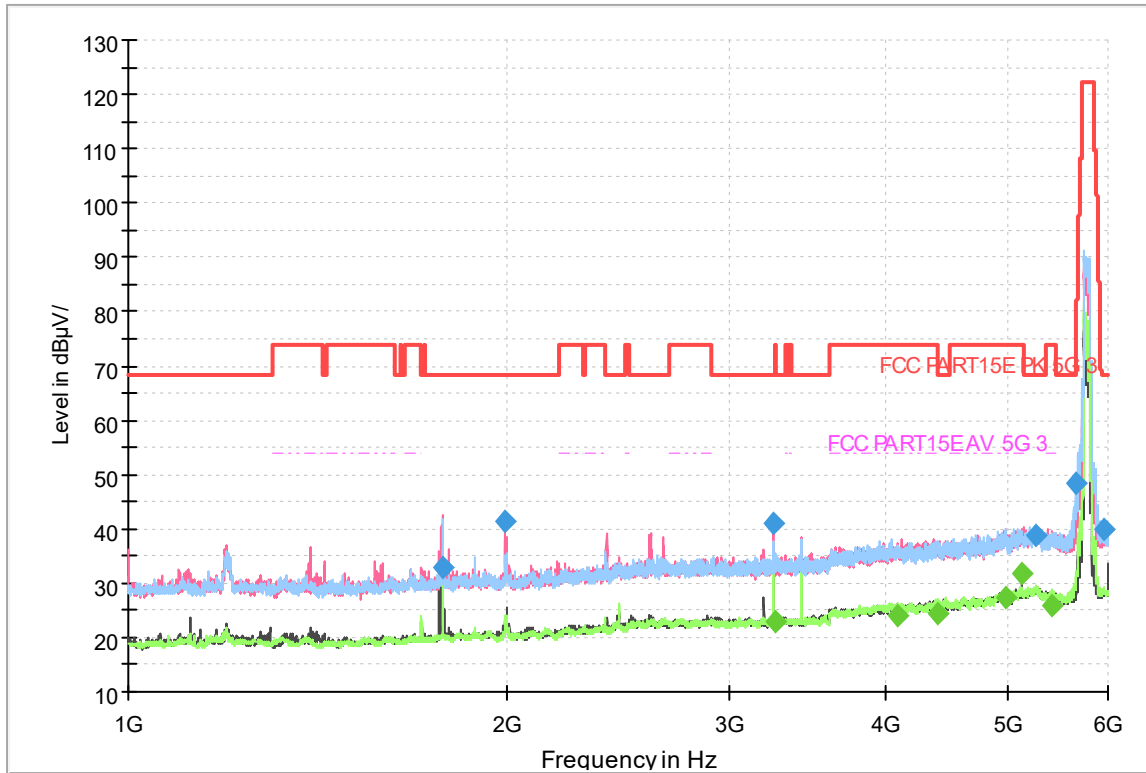

Fig.400 Radiated emission: 802.11ac(80M),CH155, 1GHz-6GHz

Final Result

Frequency (MHz)	MaxPeak (dBµV/m)	Average (dBµV/m)	Limit (dBµV/m)	Margin (dB)	Meas. Time	Bandwidth (kHz)	Height (cm)	Pol	Azimuth (deg)
1775.000000	32.96	---	68.20	35.24	50.0	1000.000	150.0	V	255.0
1990.500000	41.37	---	68.20	26.83	50.0	1000.000	150.0	V	205.0
3250.500000	40.88	---	68.20	27.32	50.0	1000.000	150.0	V	123.0
3263.000000	---	23.06	54.00	30.94	50.0	1000.000	150.0	H	38.0
4081.500000	---	24.05	54.00	29.95	50.0	1000.000	150.0	V	66.0
4397.000000	---	24.52	54.00	29.48	50.0	1000.000	150.0	H	260.0
4972.500000	---	27.46	54.00	26.54	50.0	1000.000	150.0	H	161.0
5132.000000	---	31.62	54.00	22.38	50.0	1000.000	150.0	V	102.0
5265.000000	38.67	---	68.20	29.53	50.0	1000.000	150.0	V	213.0
5420.500000	---	25.84	54.00	28.16	50.0	1000.000	150.0	H	239.0
5650.000000	48.57	---	68.20	19.63	50.0	1000.000	150.0	H	154.0
5951.000000	40.00	---	68.20	28.20	50.0	1000.000	150.0	H	118.0

Chongqing Academy of Information and Communication Technology

Address: No. 8, Yuma Road, Chayuan New City, Nan'an District, Chongqing, P. R. China, 401336
 Tel: 0086-23-88069965 FAX: 0086-23-88608777

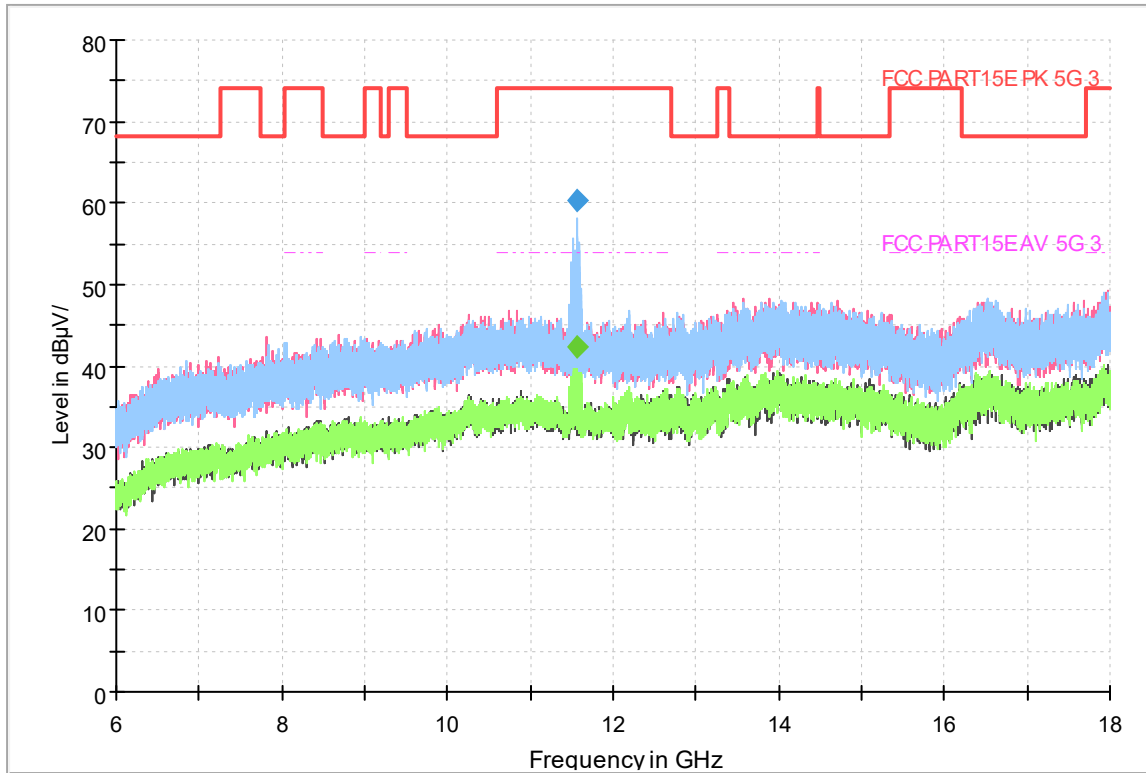

Fig.401 Radiated emission: 802.11ac(80M),CH155, 6GHz-18GHz

Final Result

Frequency (MHz)	MaxPeak (dBµV/m)	Average (dBµV/m)	Limit (dBµV/m)	Margin (dB)	Meas. Time	Bandwidth (kHz)	Height (cm)	Pol	Azimuth (deg)
11567.400000	60.36	---	74.00	13.64	50.0	1000.000	170.0	H	0.0
11576.400000	---	42.27	54.00	11.73	50.0	1000.000	170.0	H	0.0

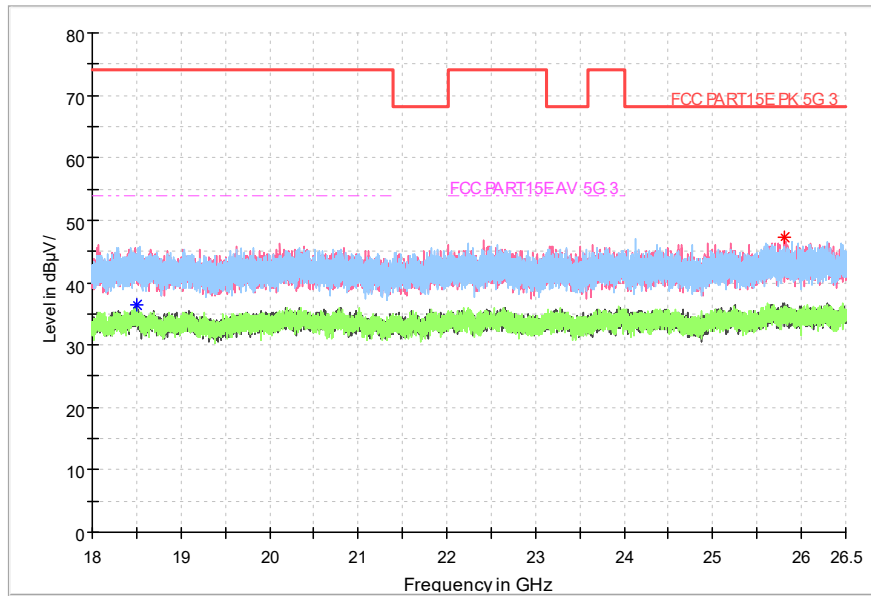

Fig.402 Radiated emission: 802.11ac(80M),CH155,18 GHz – 26.5GHz

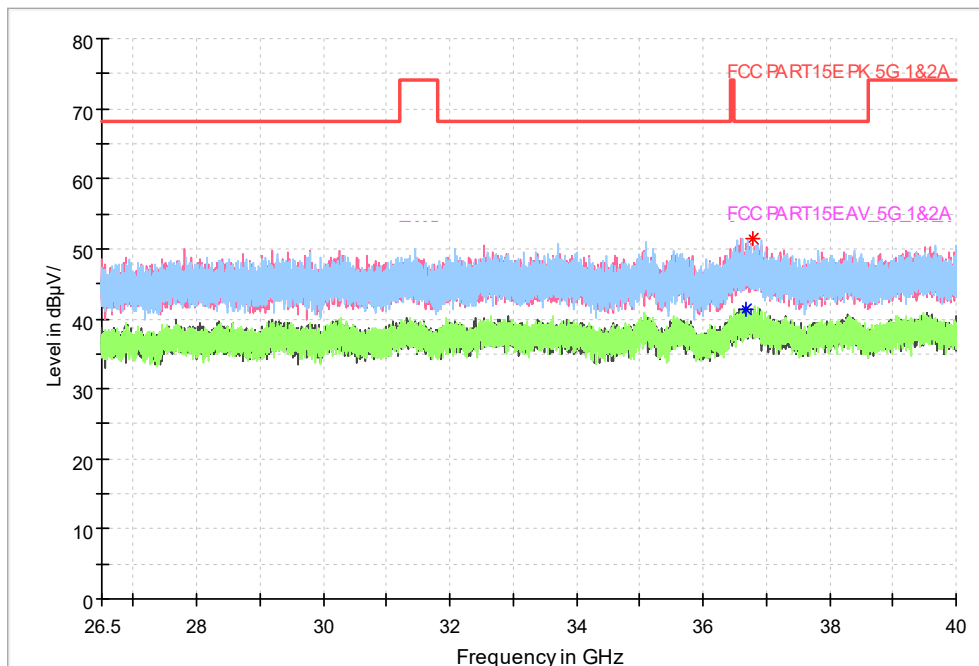

Fig.403 Radiated emission: 802.11ac(40M),CH162, 26.5 GHz – 40GHz

Test photo

See the document "Wifi_BT_Test Setup Photos".

Chongqing Academy of Information and Communication Technology

Address: No. 8,Yuma Road, Chayuan New City, Nan'an District, Chongqing, P. R. China,401336
Tel: 0086-23-88069965 FAX:0086-23-88608777

5.7 Power line Conducted Emissions

Specifications:	ANSI C63.10 voltage mains test
DUT Serial Number:	865171050693269
Test conditions:	Ambient Temperature:15°C-35°C Relative Humidity:30%-60% Air pressure: 86-106kPa
Test Results:	Pass

Limit

The EUT meets the requirement of having a peak to average ratio of less than 13dB.

For an intentional radiator which is designed to be connected to the public utility (AC) power line, the radio frequency voltage that is conducted back onto the AC power line on any frequency or frequencies within the band 150 kHz to 30 MHz shall not exceed 250 microvolt (The limit decreases linearly with the logarithm of the frequency in the range 0.15 MHz to 0.50 MHz). The limits at specific frequency range are listed as follows:

Measurement Uncertainty:

Frequency Range	Uncertainty
150 kHz to 30 MHz	1.83

Limits of the conducted disturbance at the AC mains ports:

Frequency range	Limit(Quasi-peak)	Limit(Average)
0.15 MHz to 0.5 MHz	66 dB μ V – 56 dB μ V	56 dB μ V – 46 dB μ V
>0.5 MHz to 5MHz	56 dB μ V	46 dB μ V
>5 MHz to 30 MHz	60 dB μ V	50 dB μ V

NOTE: The limit decreases linearly with the logarithm of the frequency in the range 0.15 MHz to 0.50 MHz.

Compliance with this provision shall be based on the measurement of the radio frequency voltage between each power line (LINE and NEUTRAL) and ground at the power terminals.

Test Setup

The EUT was placed in a shielding room. The WLAN TESTER was used to set the TX channel and power level. The ac adapter output is connected to Receiver through an AMN (Artificial Mains Network).

Chongqing Academy of Information and Communication Technology

Address: No. 8,Yuma Road, Chayuan New City, Nan'an District, Chongqing, P. R. China,401336
Tel: 0086-23-88069965 FAX:0086-23-88608777

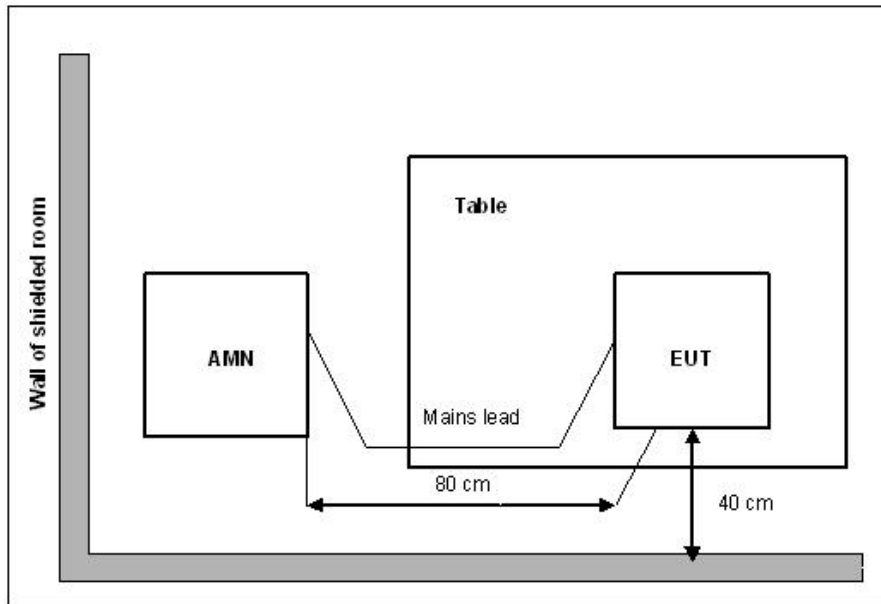

Test Procedure

1. The EUT is placed on a wooden table 80 cm above the reference ground plane.
2. The EUT is connected via LISN to a test power supply.
3. The measurement results are obtained as described below:
4. Detectors – Quasi Peak and Average Detector.

The measurement is made according to ANSI C63.10-2013.

Conclusion: PASS

Test Result:

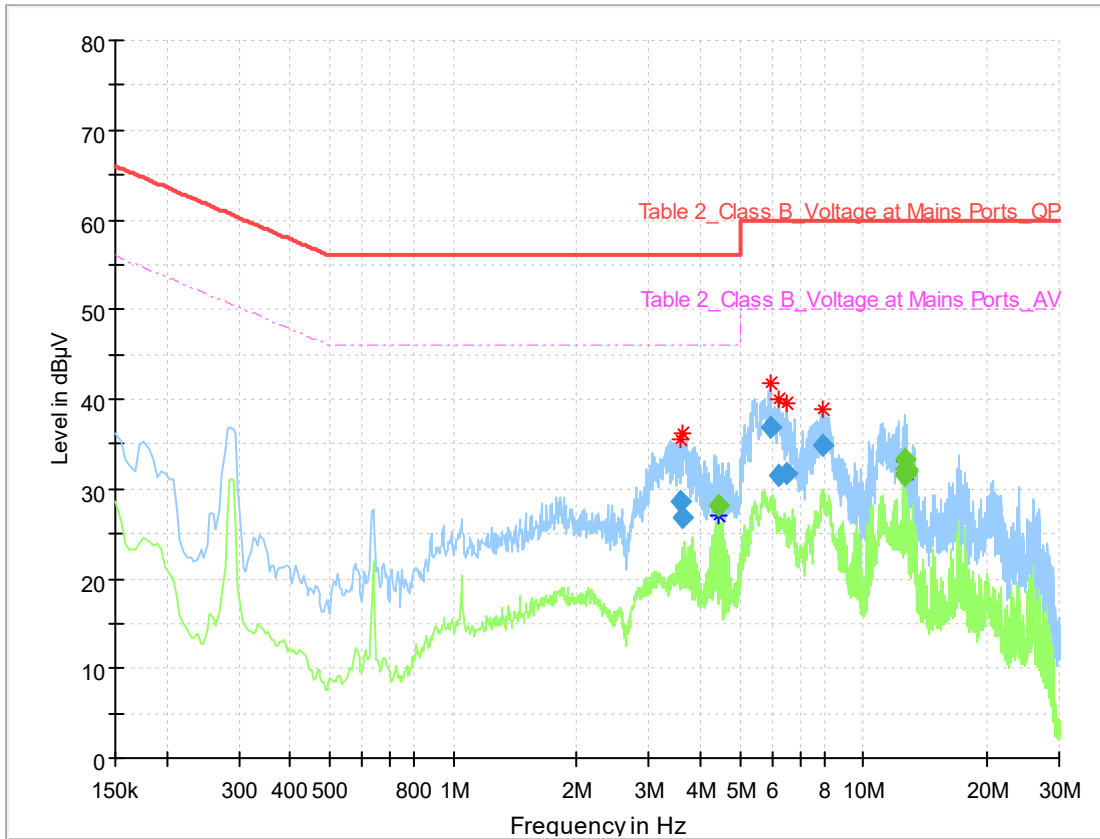

Final Result 1

Frequency (MHz)	QuasiPeak (dB µ V)	Average (dB µ V)	Limit (dB µ V)	Margin (dB)	Meas. Time	Bandwidth h	Line
3.573971	28.51	---	56.00	27.49	100.0	9.000	+
3.622257	26.72	---	56.00	29.28	100.0	9.000	+
4.408015	---	28.15	46.00	17.85	100.0	9.000	+
5.913684	36.84	---	60.00	23.16	100.0	9.000	+
6.238522	31.49	---	60.00	28.51	100.0	9.000	+
6.493125	31.74	---	60.00	28.26	100.0	9.000	+
7.968066	34.78	---	60.00	25.22	100.0	9.000	+
12.590427	---	32.20	50.00	17.80	100.0	9.000	+
12.638713	---	33.23	50.00	16.77	100.0	9.000	+
12.687000	---	31.55	50.00	18.45	100.0	9.000	+
12.726507	---	32.06	50.00	17.94	100.0	9.000	+
12.774794	---	32.08	50.00	17.92	100.0	9.000	+

Chongqing Academy of Information and Communication Technology

Address: No. 8,Yuma Road, Chayuan New City, Nan'an District, Chongqing, P. R. China,401336
 Tel: 0086-23-88069965 FAX:0086-23-88608777

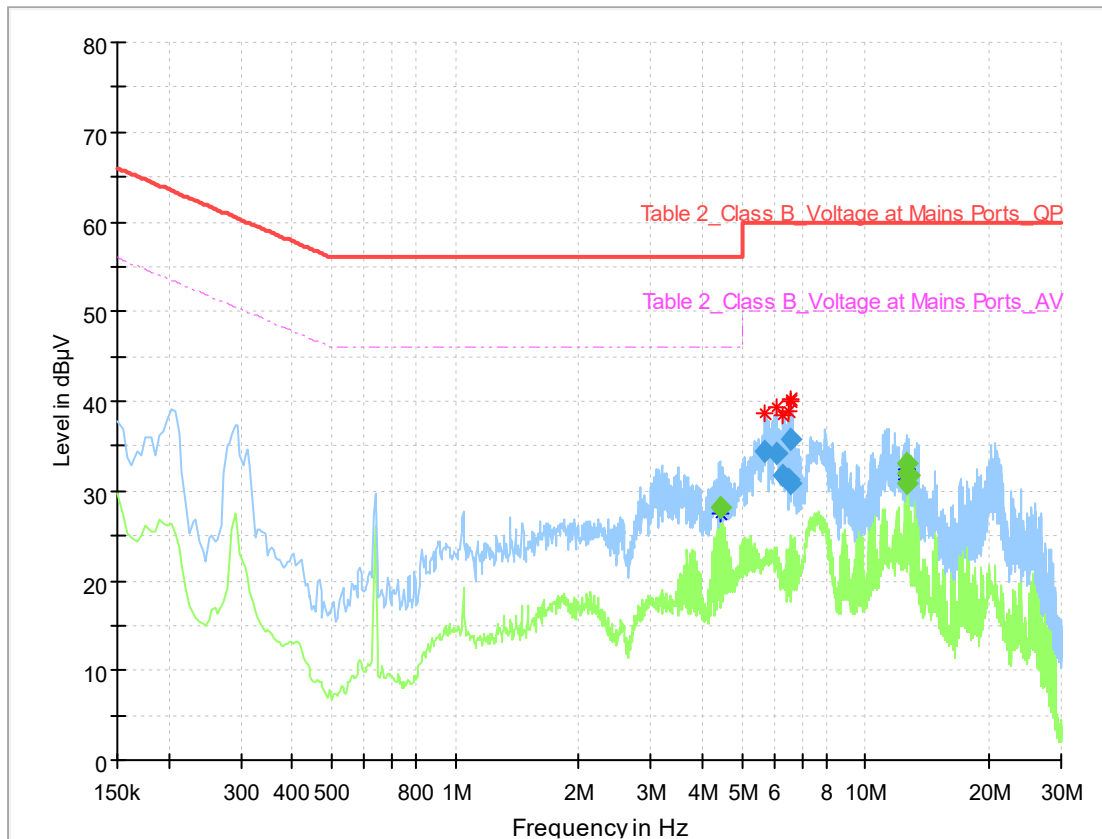

Final Result 1

Frequency (MHz)	QuasiPeak (dB µ V)	Average (dB µ V)	Limit (dB µ V)	Margin (dB)	Meas. Time	Bandwidth h	Line
4.408015	---	28.08	46.00	17.92	100.0	9.000	-
5.681029	34.32	---	60.00	25.68	100.0	9.000	-
6.093662	34.15	---	60.00	25.85	100.0	9.000	-
6.308757	31.68	---	60.00	28.32	100.0	9.000	-
6.510684	31.37	---	60.00	28.63	100.0	9.000	-
6.558971	35.68	---	60.00	24.32	100.0	9.000	-
6.607257	30.84	---	60.00	29.16	100.0	9.000	-
12.590427	---	31.95	50.00	18.05	100.0	9.000	-
12.638713	---	33.00	50.00	17.00	100.0	9.000	-
12.687000	---	30.86	50.00	19.14	100.0	9.000	-
12.726507	---	31.69	50.00	18.31	100.0	9.000	-
12.774794	---	31.76	50.00	18.24	100.0	9.000	-

Chongqing Academy of Information and Communication Technology

Address: No. 8, Yuma Road, Chayuan New City, Nan'an District, Chongqing, P. R. China, 401336
 Tel: 0086-23-88069965 FAX: 0086-23-88608777

5.8 Frequency Stability

Specifications:	FCC Part 15. 407 (g)
DUT Serial Number:	865171050693608
Test conditions:	Ambient Temperature:15°C-35°C Relative Humidity:30%-60% Air pressure: 86-106kPa
Test Results:	Pass

Limit Level Construction:

According to §15.407(g), manufacturers of U-NII devices are responsible for ensuring frequency stability such that an emission is maintained within the band of operation under all conditions of normal operation as specified in the users manual.

Measurement Uncertainty:

Item	Uncertainty
Expanded Uncertainty	18Hz (k=2)

Test Procedure:

The equipment under test was connected to an external AC or DC power supply and input rated voltage. RF output was connected to a frequency counter or spectrum analyzer via feed through attenuators. The EUT was placed inside the temperature chamber. Set the spectrum analyzer RBW low enough to obtain the desired frequency resolution and measure EUT 20°C operating frequency as reference frequency. Turn EUT off and set the chamber temperature to -20°C. After the temperature stabilized for approximately 30 minutes recorded the frequency. Repeat step measure with 10°C increased per stage until the highest temperature of +50°C reached.

Note: --

Test block diagram:

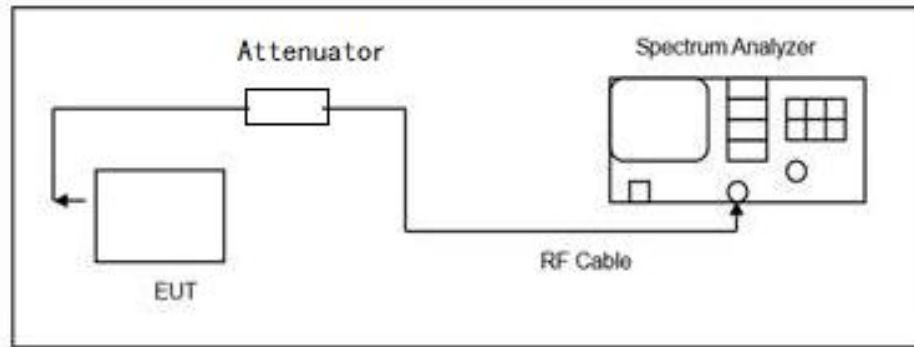

Measurement Results:

Voltage vs. Frequency Stability

5150-5250MHz:

Voltage	Measurement Frequency (MHz)
(V)	5180.0000
4.2	5179.9682
3.8	5179.9705
3.5	5179.9685
Max. Deviation (MHz)	0.032
Max. Deviation (ppm)	6.14

5250MHz-5350MHz:

Voltage	Measurement Frequency (MHz)
(V)	5260.0000
4.2	5259.9578
3.8	5259.9644
3.5	5259.9648
Max. Deviation (MHz)	0.042
Max. Deviation (ppm)	8.02

Chongqing Academy of Information and Communication Technology

Address: No. 8, Yuma Road, Chayuan New City, Nan'an District, Chongqing, P. R. China, 401336
 Tel: 0086-23-88069965 FAX: 0086-23-88608777



5470MHz-5725MHz:

Voltage	Measurement Frequency (MHz)
(V)	5500.0000
4.2	5499.9713
3.8	5499.9765
3.5	5499.9695
Max. Deviation (MHz)	0.034
Max. Deviation (ppm)	6.18

5725-5850MHz:

Voltage	Measurement Frequency (MHz)
(V)	5745.0000
4.2	5744.9752
3.8	5744.9738
3.5	5744.9685
Max. Deviation (MHz)	0.032
Max. Deviation (ppm)	5.48



Temperature vs. Frequency Stability

5150-5250MHz:

Voltage	Measurement Frequency (MHz)
(°C)	5180.0000
-20	5179.9751
-10	5179.9755
0	5179.9782
10	5179.9665
20	5179.9680
30	5179.9748
40	5179.9678
50	5179.9692
Max. Deviation (MHz)	0.034
Max. Deviation (ppm)	6.47

5250MHz-5350MHz:

Voltage	Measurement Frequency (MHz)
(°C)	5260.0000
-20	5259.9725
-10	5259.9784
0	5259.9762
10	5259.9652
20	5259.9697
30	5259.9708
40	5259.9745
50	5259.9638
Max. Deviation (MHz)	0.036
Max. Deviation (ppm)	6.88



5470MHz-5725MHz:

Voltage	Measurement Frequency (MHz)
(°C)	5500.0000
-20	5499.9602
-10	5499.9625
0	5499.9703
10	5499.9712
20	5499.9632
30	5499.9648
40	5499.9715
50	5499.9633
Max. Deviation (MHz)	0.040
Max. Deviation (ppm)	7.24

5725-5850MHz:

Voltage	Measurement Frequency (MHz)
(°C)	5745.0000
-20	5744.9713
-10	5744.9626
0	5744.9648
10	5744.9670
20	5744.9624
30	5744.9578
40	5744.9672
50	5744.9643
Max. Deviation (MHz)	0.042
Max. Deviation (ppm)	7.35

Conclusion: PASS



Report No.: I21W00039-WLAN_5.8G_Rev1

Annex A EUT Photos

See the document "SLM900-External Photos".

See the document "SLM900-Internal Photos".

Chongqing Academy of Information and Communication Technology

Address: No. 8, Yuma Road, Chayuan New City, Nan'an District, Chongqing, P. R. China, 401336
Tel: 0086-23-88069965 FAX: 0086-23-88608777



Report No.: I21W00039-WLAN_5.8G_Rev1

ANNEX B Deviations from Prescribed Test Methods

No deviation from Prescribed Test Methods.

*****END OF REPORT*****

Chongqing Academy of Information and Communication Technology

Address: No. 8, Yuma Road, Chayuan New City, Nan'an District, Chongqing, P. R. China, 401336
Tel: 0086-23-88069965 FAX: 0086-23-88608777