

MEIG EVB
User Guide

1 MEIG EVB Introduction

MEIG EVB is a functional development demo board that matches the SLM75X series modules. The interface layout is as follows:

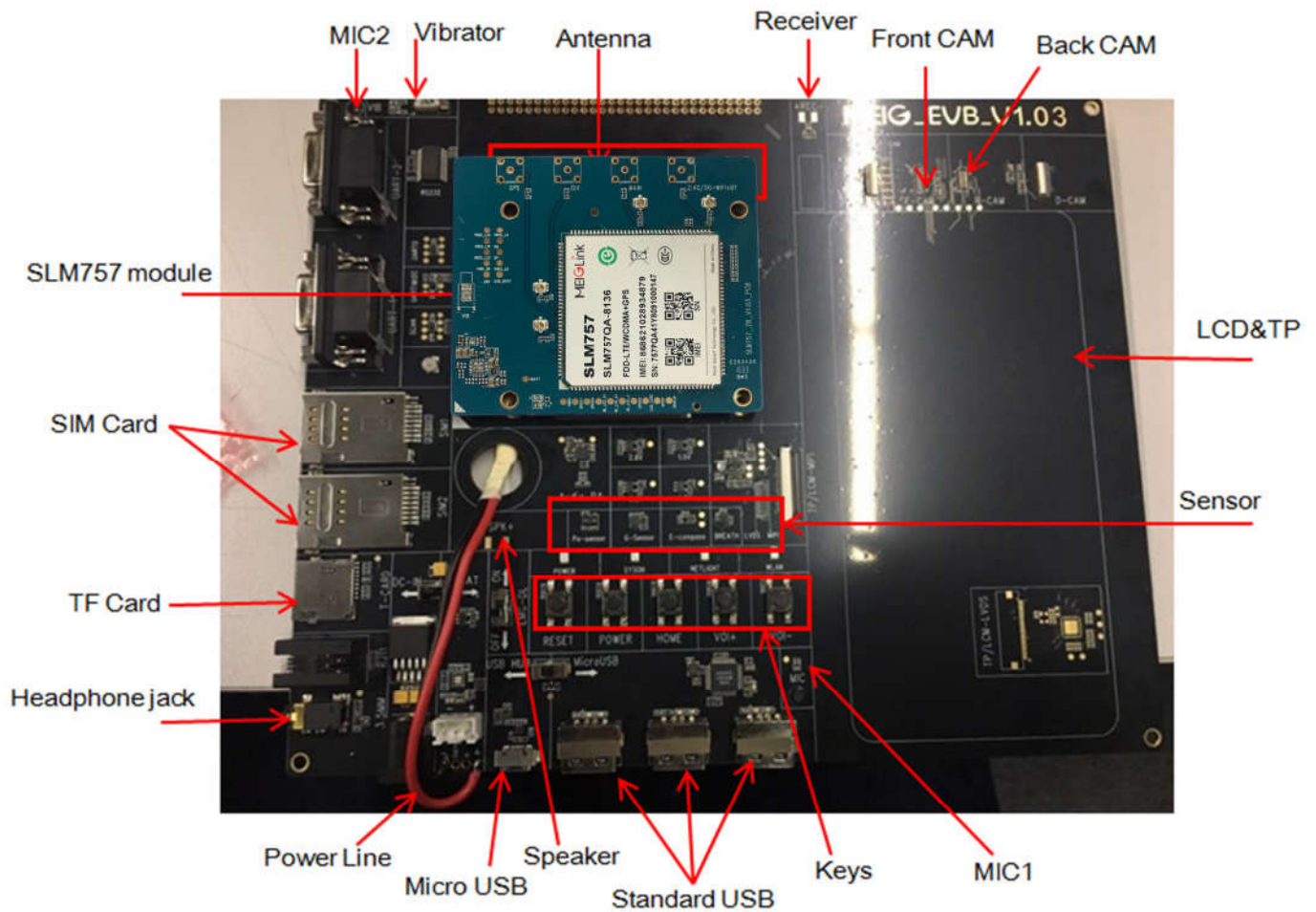

2 MEIG EVB Hardware resource feature list

Product Features	Description
LCD	30pin ZIF, 4 Lane MIPI-ZIF Signal interface, PWM regulator backlight, Capacitive touch screen
Front CAM	30pin B2B, 4 Lane MIPI-B2B Signal interface
Back CAM	24pin B2B, 4 Lane MIPI-B2B Signal interface, autofocus
Standard interface resources	Two DB9 RS232 serial port 3.5mm stereo audio output interface Two-way microphone input board (1 main MIC, all the way noise reduction MIC), One way speaker output in the board One Road vibration motor Two groups of SIM card interface, hot swappable One T-card socket, hot swappable One way micro USB interface

	Three USB2.0 interface 5V DC voltage input
On-board ready to use resources	Five keys (Poweron、Vol+、Vol-、Homekey、Reset) Gravity sensor Ambient light and proximity sensor Compass chip
Expansion interface resources	One 25pin ZIF, Used for external expansion of two-dimensional code scanning head A group of 1.8V expansion interface resources for external expansion of fingerprints or thermal printer and other functions (including SPI, I2C)
PCB size specifications	Layers: 4 Size: 220mm*180mm*1.5mm

3 MEIG EVB Interface Description

3.1 LCD Interface

MEIG EVB provides a LCD interface, a group of 30pin ZIF connector, ZIF connector with a 5-inch LCD, QHD resolution. The LCD with the TP for the capacitive TP, Driver IC on the touch screen FPC, EVB interface is for the I2C communication interface.

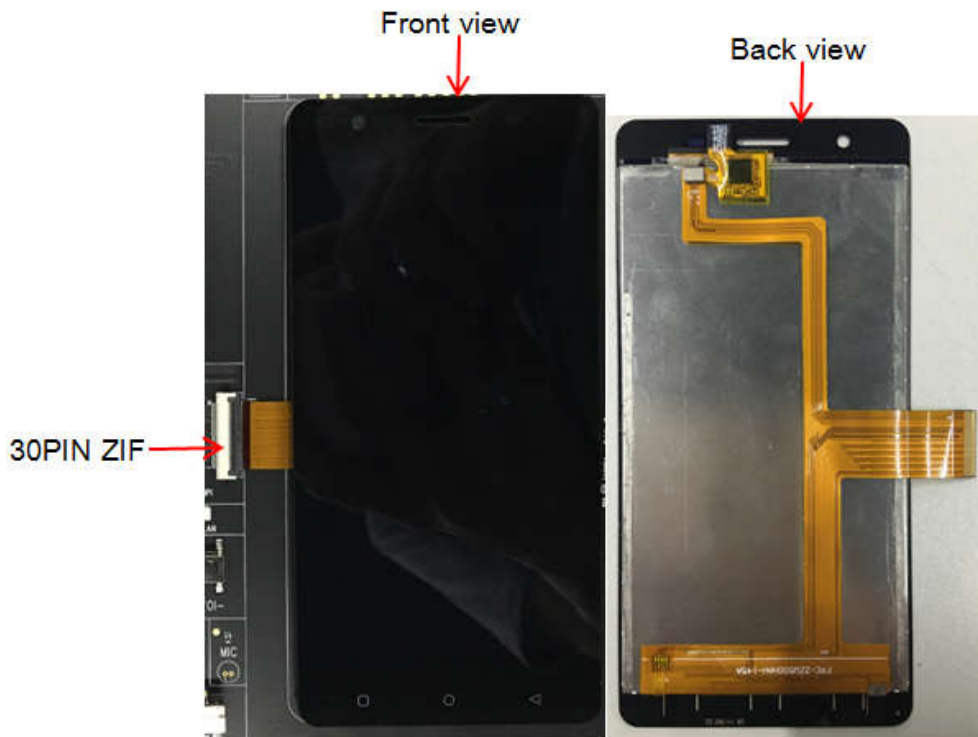

3.2 Power Interface

5V DC power supply, power line as shown below:

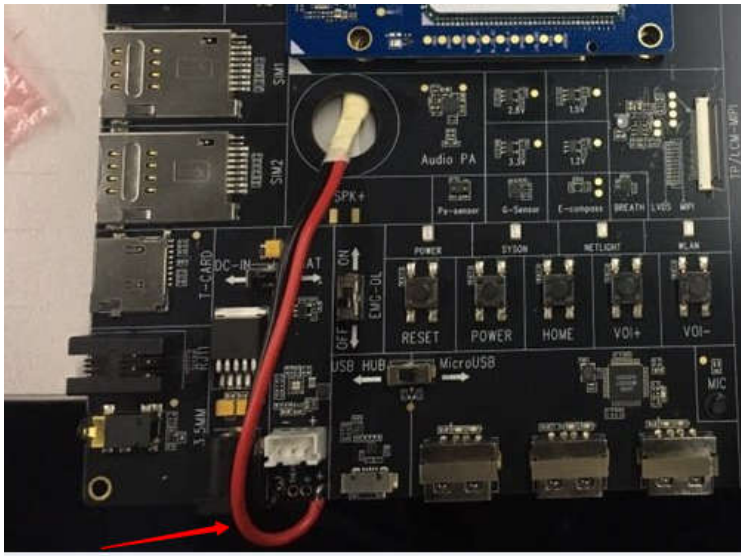

3.3 USB_BOOT Test Point

There are USB_BOOT and VREG_L6_1P8 two test points in the SLM757 core board foot and EVB middle position, VREG_L6_1P8 is 1.8V voltage output; USB_BOOT is pulled up to 1.8V will force the system into download mode. These two test points are shorted for die download and emergency download mode.

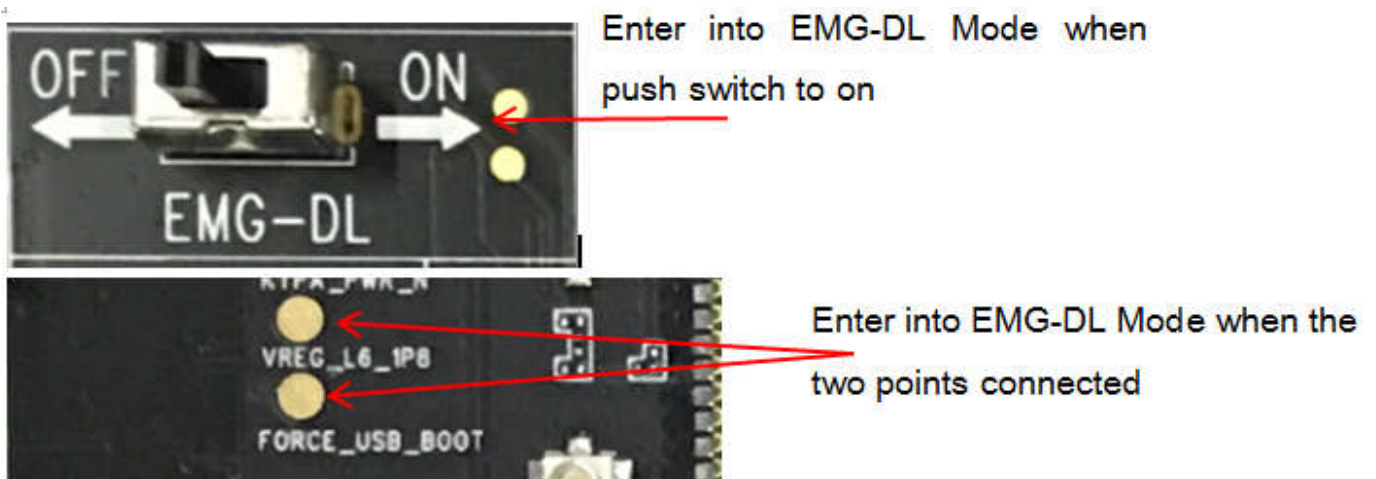

3.4 SIM Card

MEIG EVB supports two groups of SIM cards, both hot-swappable, dual-SIM dual standby. You can use the SIM card for calls, text messages, Internet access and other operations, , as shown below:

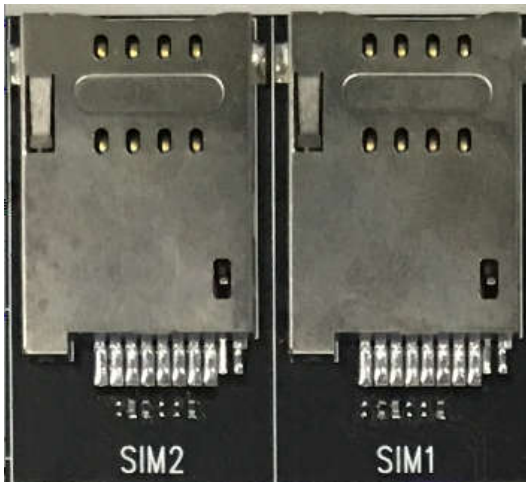

3.5 Antenna interface

MEIG EVB has a total of 4 antenna interfaces, and compatible with the coaxial interface, Connected to the antenna, you can carry out the relevant functional operation, such as dial number, as shown below:

GPS ANT DIV ANT MAIN ANT 2.4G/5G ANT



3.6Antenna information

The Antenna used in this project is ipex Fixed External Antenna provided by sunnyway with 0db gain in the low frequency and 1db gain in high frequency.



3.7 microstrip line

MEIG EVB Instructions for 50 ohm microstrip wire on printed circuit board to antenna connector:

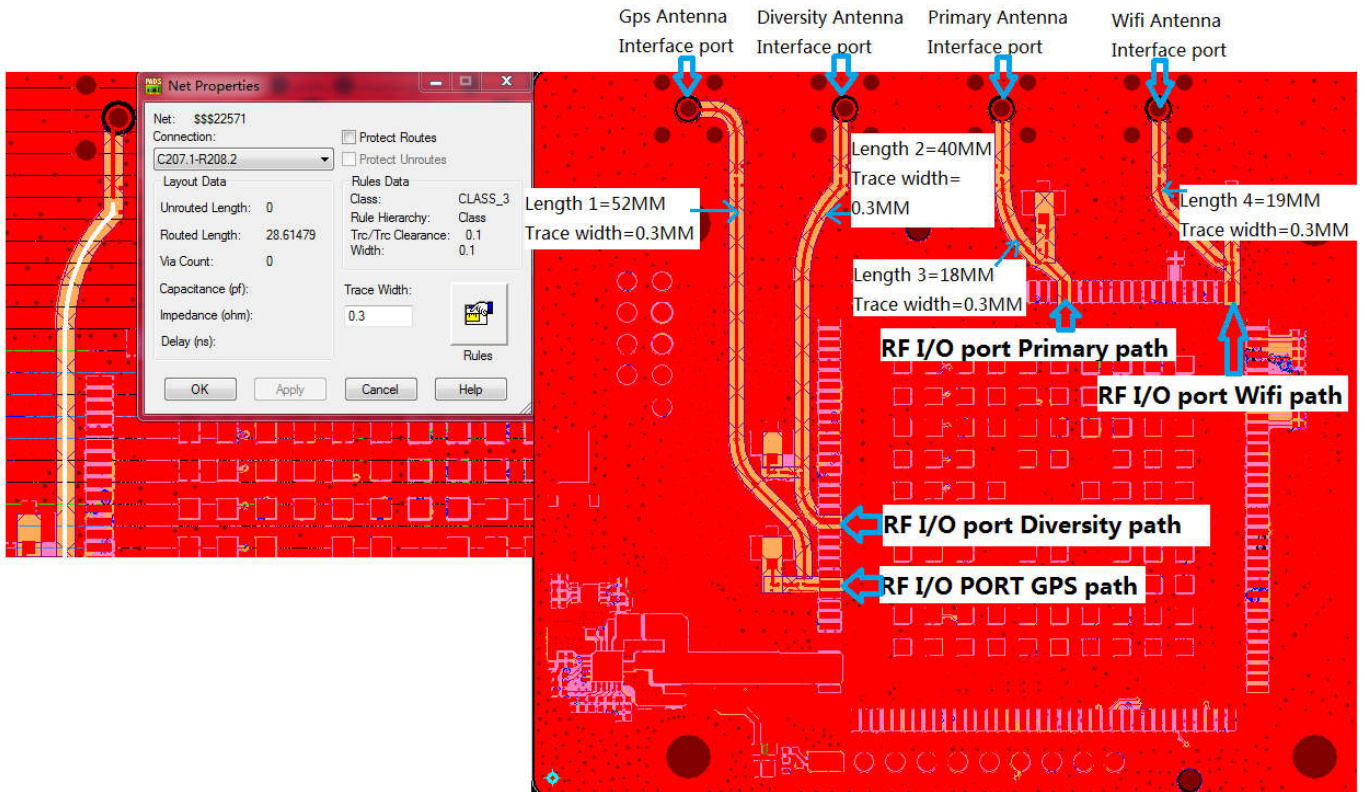

3.8 Keys

MEIG EVB has 5 keys, you can choose the button to carry out the corresponding function operation.



3.9 USB Interface

MEIG EVB USB has two external interfaces, the first for the micro USB external interface, support for USB debugging, OTG functions, U disk and other functions; the second is USB HUB for three sets of standard USB ports. The above two modes can be switched by DIP switch selection.

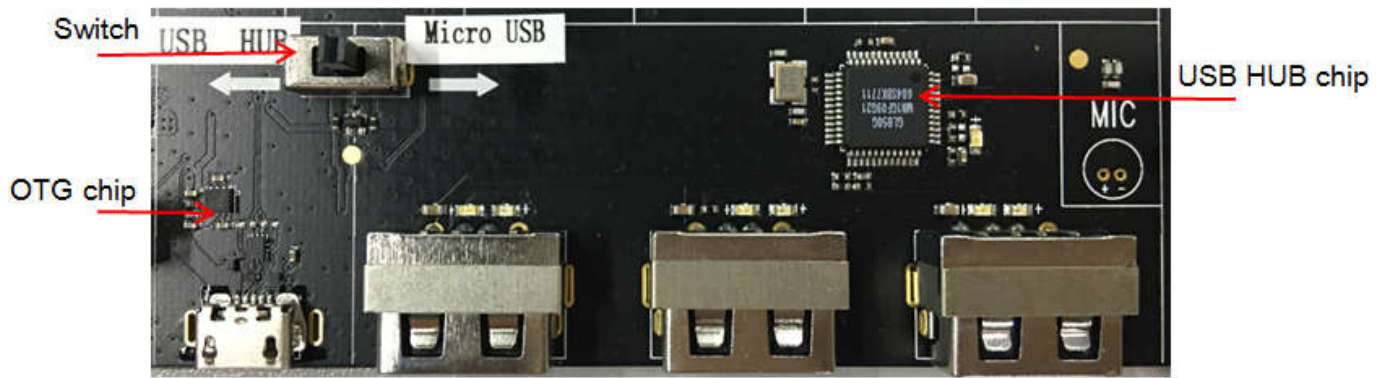

3.10 Headset Interface

Headset jack supports a 3.5mm headphone jack.

3.11 T卡 T Card

The push-push T card connector used in the MEIG EVB supports hot plugging.

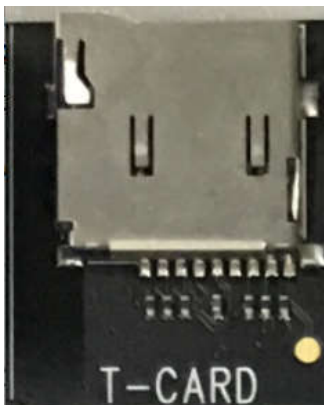

3.12 Camera

MEIG EVB supports two cameras. The back camera uses 24pin B2B interface connector to connect. Front connection using 30pin B2B interface connector. Pixel respectively is 8M pixels and front 5M pixels.

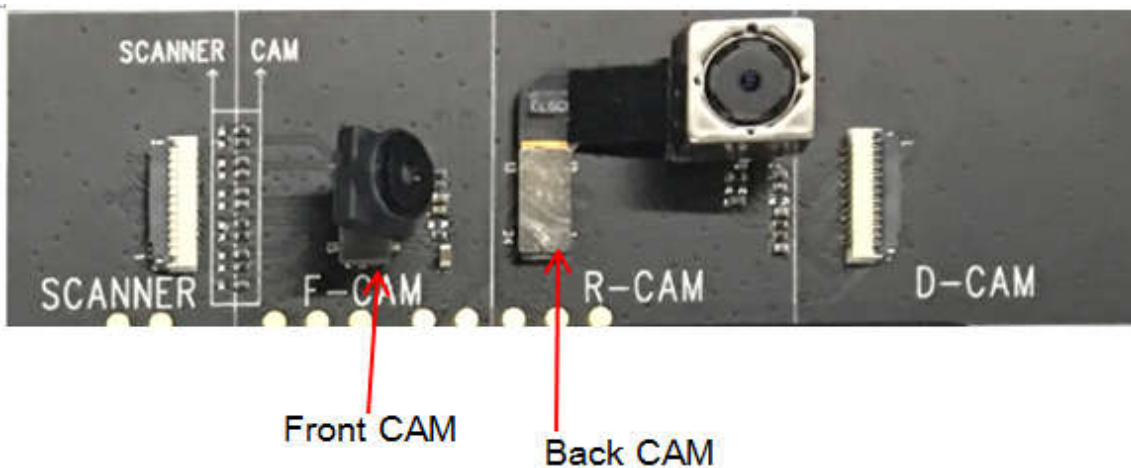

4 Attentions

1. The interface and operation will be slightly different from the actual, please prevail.
2. The product body is subject to change without notice.
3. Before using the product, please read the instruction manual carefully.
4. Do not subject the product to strong shocks and vibrations (eg falling from a height).
5. Do not place this product near heaters and cooking places, do not expose the product to fumes, steam.
6. Please avoid direct sunlight, do not place the product in high temperature, high humidity and dusty places.
7. Do not wipe the product with organic solvents.
8. Please stop using this product if there is any abnormal phenomenon such as smoke, odor, noise or heat during use. Please stop using this product if it is wet or damaged.
9. Avoid using this product in a dusty environment, because it may affect the measured value, resulting in product failure.
10. Do not allow toddlers and children to play the products and accessories, preventing young children and children from disassembling and swallowing parts.
11. The company must be authorized by the after-sales service personnel for inspection and maintenance when products are damaged

FCC Regulations:

This device complies with part 15 of the FCC Rules. Operation is subject to the following two conditions: (1) This device may not cause harmful interference, and (2) This device must accept any interference received, including interference that may cause undesired operation.

This device has been tested and found to comply with the limits for a Class B digital device , pursuant to Part 15 of the FCC Rules. These limits are designed to provide reasonable protection against harmful interference in a residential installation. This equipment generates, uses and can radiated radio frequency energy and, if not installed and used in accordance with the instructions, may cause harmful interference to radio communications. However, there is no guarantee that interference will not occur in a particular installation If this equipment does cause harmful interference to radio or television reception, which can be determined by turning the equipment off and on, the user is encouraged to try to correct the interference by one or more of the following measures:

- Reorient or relocate the receiving antenna.
- Increase the separation between the equipment and receiver.
- Connect the equipment into an outlet on a circuit different from that to which the receiver is connected.
- Consult the dealer or an experienced radio/TV technician for help.

Caution: Changes or modifications not expressly approved by the party responsible for compliance could void the user's authority to operate the equipment.

RF Exposure Information

This device complies with FCC radiation exposure limits set forth for an uncontrolled environment. In order to avoid the possibility of exceeding the FCC radio frequency exposure limits, human proximity to the antenna shall not be less than 20cm (8 inches) during normal operation.

ISED Notice

This device complies with Innovation, Science and Economic Development Canada license-exempt RSS standard(s). Operation is subject to the following two conditions:

- (1) this device may not cause interference, and
- (2) this device must accept any interference, including interference that may cause undesired operation of the device.

Le présent appareil est conforme aux CNR Innovation, Sciences et Développement économique Canada applicables aux appareils radio exempts de licence. L'exploitation est autorisée aux deux conditions suivantes:

- (1) l'appareil ne doit pas produire de brouillage, et
- (2) l'utilisateur de l'appareil doit accepter tout brouillage radioélectrique subi, même si le brouillage est susceptible d'en

This device complies with the Canadian ICES-003 Class B specifications.
CAN ICES-3(B)/ NMB-3(B)

ISED Radiation Exposure Statement

This device complies with RSS-102 radiation exposure limits set forth for an uncontrolled environment. In order to avoid the possibility of exceeding the ISED radio frequency exposure limits, human proximity to the antenna shall not be less than 20cm (8 inches) during normal operation.

Cet appareil est conforme aux limites d'exposition aux rayonnements de la CNR-102 définies pour un environnement non contrôlé. Afin d'éviter la possibilité de dépasser les limites d'exposition aux fréquences radio de la CNR-102, la proximité humaine à l'antenne ne doit pas être inférieure à 20 cm (8 pouces) pendant le fonctionnement normal.

IMPORTANT NOTE:

This module is intended for OEM integrator. The OEM integrator is still responsible for the FCC compliance requirement of the end product, which integrates this module. 20cm minimum distance has to be able to be maintained between the antenna and the users for the host this module is integrated into. Under such configuration, the FCC radiation exposure limits set forth for an population/uncontrolled environment can be satisfied.

Any changes or modifications not expressly approved by the manufacturer could void the user's authority to operate this equipment.

USERS MANUAL OF THE END PRODUCT:

In the users manual of the end product, the end user has to be informed to keep at least 20cm separation with the antenna while this end product is installed and operated. The end user has to be informed that the FCC radio-frequency exposure guidelines for an uncontrolled environment can be satisfied. The end user has to also be informed that any changes or modifications not expressly approved by the manufacturer could void the user's authority to operate this equipment. If the size of the end product is smaller than 8x10cm, then additional FCC part 15.19 statement is required to be available in the users manual: This device complies with Part 15 of FCC rules. Operation is subject to the following two conditions: (1) this device may not cause harmful interference and (2) this device must accept any interference received, including interference that may cause undesired operation.

LABEL OF THE END PRODUCT:

The final end product must be labeled in a visible area with the following " Contains Transmitter Module FCC ID: 2APJ4-SLM757A". If the size of the end product is larger than 8x10cm, then the following FCC part 15.19 statement has to also be available on the label: This device complies with Part 15 of FCC rules.

Operation is subject to the following two conditions: (1) this device may not cause harmful interference and (2) this device must accept any interference received, including interference that may cause undesired operation.

The Innovation, Science and Economic Development Canada certification label of a module shall be clearly visible at all times when installed in the host device; otherwise, the host device must be labeled to display the Innovation, Science and Economic Development Canada certification number for the module,

preceded by the words "Contains transmitter module IC: 23860-SLM757A".

The device is going on be operated in 5150~5250 frequency range. It is restricted indoor environment only in Canada.