

MeiG SLM320 Hardware Design Manual

Controlled Version Number: V1.2

Release date: 2021-06-18



Important Notice

Copyright Notice

All rights reserved. MeiG Smart Technology Co., Ltd

This manual and all its contents are owned by MeiG Smart Technology Co., Ltd and protected by Chinese laws and relevant copyright laws in applicable international conventions. Without the written authorization of MeiG Smart Technology Co., Ltd, no one may copy, disseminate, distribute, modify or use part or all of this manual in any form, and the offenders will be held responsible according to law.

Statement of No Guarantee

MeiG Smart Technology Co., Ltd makes no representations or guarantees, either express or implied, for any contents in this document, and assumes no responsibility for the merchantability and fitness for a particular purpose or any indirect, extraordinary or consequential losses.

Confidentiality Claim

The information contained in this document (including any annexes) is confidential. The recipient understands that the document obtained by him is confidential and shall not be used for any purpose other than the stated purpose, and he shall not disclose this document to any third party.

Disclaimer

The company assumes no responsibility for property damage or personal injury caused by customers' improper operation. Customers are requested to develop corresponding products according to the technical specifications and reference designs in the manual. Before the disclaimer, the company has the right to change the contents of this manual according to the needs of technological development, and the version is subject to change without further notice.

Revision History

Revision	Date	Description
V1.0	2020-04-21	First edition
V1.1	2021-04-22	Modify file format and correct description
V1.2	2021-06-18	Update SLM320-LA frequency information and added RF performance for B2/B4

Contents

Important Notice	1
Revision History	2
Contents	3
1 Introduction	5
1.1 Safety instruction	6
2 Product Overview	7
2.1 General Description	7
2.2 Key Features.....	7
2.3 Functional block diagram.....	10
2.4 Evaluation Kit.....	11
3 Application Interface	12
3.1 General Description	12
3.2 Pin Assignment.....	13
3.3 PIN Description	14
3.4 Power source	22
3.4.1 Power Supply	23
3.4.2 Reduce voltage drop.....	23
3.4.3 Power Supply Reference Circuit.....	24
3.4.4 VDD_EXT voltage output.....	24
3.5 Start up.....	25
3.5.1 PWRKEY Pin boot	25
3.5.2 Power off.....	26
3.6 Reset Function.....	26
3.6.1 Hardware Reset.....	26
3.6.2 AT command Reset	27
3.7 USIM/SIM Interface.....	28
3.8 USB port.....	30
3.8.1 USB Pin Description	30
3.8.2 USB Reference Circuit.....	30
3.9 Serial Port	31
3.10 Status indication	33
3.11 Low Power Mode.....	35
3.11.1 Flight mode	35
3.11.2 Sleep mode.....	35
3.11.3 Ultra low power mode	36
3.12 ADC Function	36
3.13 USB_BOOT Port.....	37
4 GNSS Receiver	38
4.1 General Description	38
4.2 GNSS Performance	38
4.3 Layout Guidelines	38
4.4 Antenna connection	38
5 Antenna interface	39
5.1 Introduction to Antenna Interface	39

5.2	Radio frequency reference circuit.....	39
5.3	Installation of antenna.....	40
5.3.1	Antenna requirements.....	40
5.3.2	RF output power	41
5.3.3	RF reception sensitivity.....	42
5.3.4	Working frequency	43
5.3.5	OTA Antenna requirements	45
6	Electrical characteristics	46
6.1	Absolute Maximum Ratings.....	46
6.2	Ambient Temperature Range	46
6.3	Electrical Characteristics of Interface Working State	46
6.4	Module Power Consumption Range.....	47
6.5	Environmental reliability requirements.....	78
6.6	ESD character.....	78
7	Mechanical characteristics	80
7.1	Module Mechanical Dimensions.....	80
7.2	Recommended Footprint	81
7.3	Top View of Module	82
7.4	Bottom View of Module.....	82
8	Storage and production	83
8.1	Storage.....	83
8.2	Reflow Profile.....	83
8.3	Packaging	84
9	Appendix A refers to documentation and term abbreviations	85
9.1	Reference File.....	85
9.2	Symbol Key.....	85
10	Appendix B GPRS Coding Scheme	89

1 Introduction

This document describes SLM320 module air interface and hardware interface that connected to the clients' applications.

This document can help customers quickly understand SLM320 module interface specification, electrical characteristics, mechanical specifications and related product information. With the help of this document, combined with our application manual and user instructions, customers can quickly apply SLM320 module to wireless IoT applications.

SLM320 Wireless module is a wide band wireless terminal product applicable to TDD-LTE/FDD-LTE/GSM, a variety of network standards.







SLM320 Supports access rate:

- TDD-LTE:8Mbps/2Mbps;
- FDD-LTE:10Mbps/5Mbps;
- GPRS: 85.6kbps/85.6kbps;

SLM320 not only provides wireless data access, but also provides voice mesdrope and other functions. SLM320 can be widely used in the field of M2M, such as OBD, CPE, router, data card, DTU, security and industrial PDA, etc.

1.1 Safety instruction

Following below safety principles, user could ensure personal safety and protect products and work environment from potential damage.

	<p>Driving safety first! Do not use a hand-held mobile terminal while driving, unless it has a hands-free function. Stop before making a call!</p>
	<p>Before boarding, please turn off the wireless function of the mobile terminal. It is prohibited to turn on the wireless function of the mobile terminal on the airplane to prevent interference with the airplane communication system. Ignoring this prompt may lead to flight safety or even violate the law.</p>
	<p>In a hospital or health care setting, be aware that there are mobile terminal devices that may need to be turned off because limited RF interference will cause medical devices to malfunction.</p>
	<p>The mobile terminal device will not be able to connect effectively under all circumstances. If the mobile device has no phone charge or the SIM is invalid, please remember to make an emergency call when you encounter the above situations in an emergency, and ensure that your device is turned on and in an area with sufficient signal strength.</p>
	<p>Your mobile terminal device will receive and transmit rf signals when it is turned on. When it is close to TV, radio, computer or other electronic devices, RF interference will be generated.</p>
	<p>Keep mobile devices away from flammable gases. When you are near a gas station, oil depot, chemical plant or explosion site, turn off mobile terminals. Operating electronic devices in any potentially explosive site is a safety hazard.</p>

2 Product Overview

2.1 General Description

SLM320 is a wireless communication module that supports TDD-LTE/FDD-LTE/GSM, supports TDD-LTE FDD-LTE GPRS network data connection, and can provide digital voice (PCM) and analog voice, SMS and other functions such as Wi-Fi Scan/BT, GNSS* (GPS/GLONASS/BD).

Table 1 SLM320 modules frequency band

Internet	SLM320-E	SLM320-C	SLM320-LA
TDD-LTE	B38/40/41	B34/B38/39/40/41	B40
FDD-LTE	B1/B3/B5/B7/B8/B20	B1/B3/B5/B8	B1/B2/B3/B4/B5/B7/B8/B20/B28
GSM	850/900/1800/1900	850/900/1800	850/900/1800/1900

Note:

* GNSS is optional with a specified PN of the SLM320 module

SLM320 adopts highly integrated design scheme of the RF and baseband integrated on a single PCB, The baseband signal processing and audio signal processing functions adopt a single-sided layout, and the module structure size is: 32.0×29.0×2.4mm. SLM320 can be widely used in field of M2M, for example, OBD, CPE, routers, DTU, security and industrial-grade PDA etc.

2.2 Key Features

The following table describes the detailed features of SLM320 module.

Table 2 Key features of SLM320 module

Features	Details
Power supply	<ul style="list-style-type: none"> ● VBAT Supply voltage range: 3.4V~4.5V ● Typical supply voltage: 3.8V
Transmitted power	<ul style="list-style-type: none"> ● Class 4 (33dBm±2dB) for GSM900 PCL5 ● Class 1 (30dBm±2dB) for DCS1800 PCL0 ● Class E2 (27dBm±3dB) for GPRS900 PCL8 ● Class E2 (26dBm±3dB) for GPRS1800 PCL2 ● Class 3 (23dBm±2.7dB) for FDD-LTE bands ● Class 3 (23dBm±2.7dB) for TDD-LTE bands

LTE Characteristic	<ul style="list-style-type: none"> ● The maximum support CAT1 Bis ● Support 1.4 ~ 20 MHz radio frequency bandwidth ● FDD: The maximum UL rate is 5Mbps, and the maximum DL rate is 10Mbps ● TDD: The maximum UL rate is 2Mbps, and the maximum DL rate is 8Mbps
GSM character	<ul style="list-style-type: none"> ● CSD transmission rate: 9.6 KBPS, 14.4 KBPS ● Support GPRS multi-slot class 12 (the default is 12) ● Coding formats: / CS-1/CS -2/CS --3 and CS - 4 ● Maximum 4 RX slots per frame
Network protocol features	<ul style="list-style-type: none"> ● Embedded TCP/IP and UDP/IP protocol stack
Short Message service (SMS)	<ul style="list-style-type: none"> ● Text and PDU mode ● point-to-point MO and MT ● Short Message storage: stored in the SIM card by default ● Cell broadcast
GNSS character	<ul style="list-style-type: none"> ● Cold start time < 40S ● Hot start time < 5S ● Tracking sensitivity -160dBm ● Acquisition sensitivity -147dBm ● Position accuracy < 3m ● GNSS Data type: NMEA-0183
USIM Port	<ul style="list-style-type: none"> ● Support USIM/SIM: 1.8V and 3V
Audio Features	<ul style="list-style-type: none"> ● Support 1 channel digital audio interface: PCM port ● Support analog MIC signal input interface all the way ● Support one loudspeaker signal output interface (0.8W@4.2V /D, 0.6W@4.2V/AB)
PCM Interface	<ul style="list-style-type: none"> ● For audio use, external CODEC chip is required
USB Interface	<ul style="list-style-type: none"> ● Support USB2.0 ● To the AT command, data transmission, software debugging and software upgrades ● USB drive: Support Windows7, Windows 8/8.1, Windows10
Serial Interface	<p>The serial port:</p> <ul style="list-style-type: none"> ● To AT commands and data transmission ● Baud rate is default 115200bps ● Support RTS and CTS hardware flow control <p>DBG Port:</p> <ul style="list-style-type: none"> ● To develop debug, the log output ● Baud rate is default 115200bps
SD Interface	<ul style="list-style-type: none"> ● Conforms to SD3.0 protocol
AT Commands	<ul style="list-style-type: none"> ● Comply with 3GPP TS 27.007, 27.005, and MeiG enhanced AT command
Network Indicator	<ul style="list-style-type: none"> ● NET_STATUS, NET_MOD these two pins indicate the state of the network

Antenna Interface	<ul style="list-style-type: none"> ● Main antenna interface (ANT_MAIN)
Physical Property	<ul style="list-style-type: none"> ● Size: 32.0×29.0×2.4mm ● Weight: 7 gram
Temperature Range	<ul style="list-style-type: none"> ● Normal operating temperature: -30℃~+75℃ ● Storage temperature: -40℃~+85℃
Software Upgrading	<ul style="list-style-type: none"> ● USB port/FOTA
RoHS	<ul style="list-style-type: none"> ● All devices comply fully with EU RoHS standards
Environment Humidity	<ul style="list-style-type: none"> ● 5%~95%
ESD	<ul style="list-style-type: none"> ● GND:+ 8 KV air discharge, the contact discharge plus or minus 4 KV ● Antenna interface: air discharge ±8KV, contact discharge ±4KV
Package	<ul style="list-style-type: none"> ● 144 Pin LGA+LCC port
LCC Functional Interface	<ul style="list-style-type: none"> ● Power interface ● USB2.0 High-Speed port ● UART interface ● USIM/SIM port (support 3V、1.8V) ● PCM interface ● MIC input interface ● Speaker output interface ● Hardware reset interface ● Indicator interface ● Keyboard interface ● Sleep control interface ● Flight mode control interface ● ADC interface ● I2C interface ● SPI interface ● SD interface ● USB_BOOT port

2.3 Functional block diagram

Following is the functional block diagram of SLM320, illustrating its main functions.

- PMU
- BBU
- Internal memory
- The radio frequency part
- peripheral interface

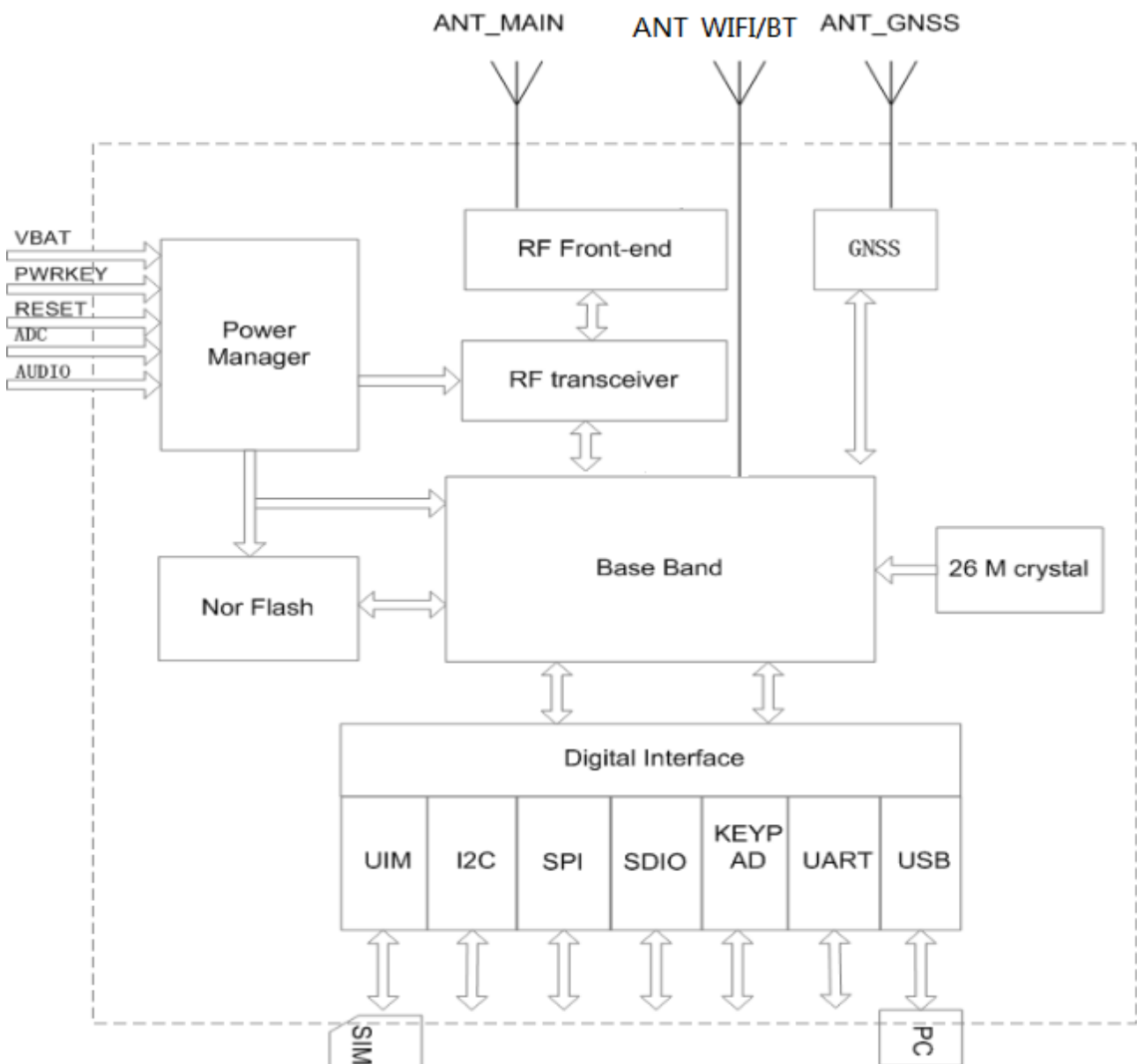

Figure 1 Functional block diagram

2.4 Evaluation Kit

To facilitate testing and use of the SLM320 module, MeiG provides an evaluation Kit to customer. Evaluation Kit includes USB cables, antennas, and other peripherals.

Please refer to the specific use method of evaluation board *MeiG_SLM320_Mini PCIe_EVB_UGD*

MeiG Confidential

3 Application Interface

3.1 General Description

SLM320 adopts LCC+LGA interface, total 144 pins, including 80 LCC pins and 64 LGA pins, providing the following functional interfaces:

- Power port
- USB2.0 High-Speed port
- UART port
- USIM/SIM port (support 3V、1.8V)
- PCM port
- MIC input interface
- The speaker output interface
- Hardware reset interface
- Pilot light interface
- Keyboard interface
- Sleep control interface
- Flight mode control interface
- ADC port
- I2C port
- SPI port
- SD port
- USB_BOOT port

3.2 Pin Assignment

The following figure shows the pin assignment of SLM320 module.

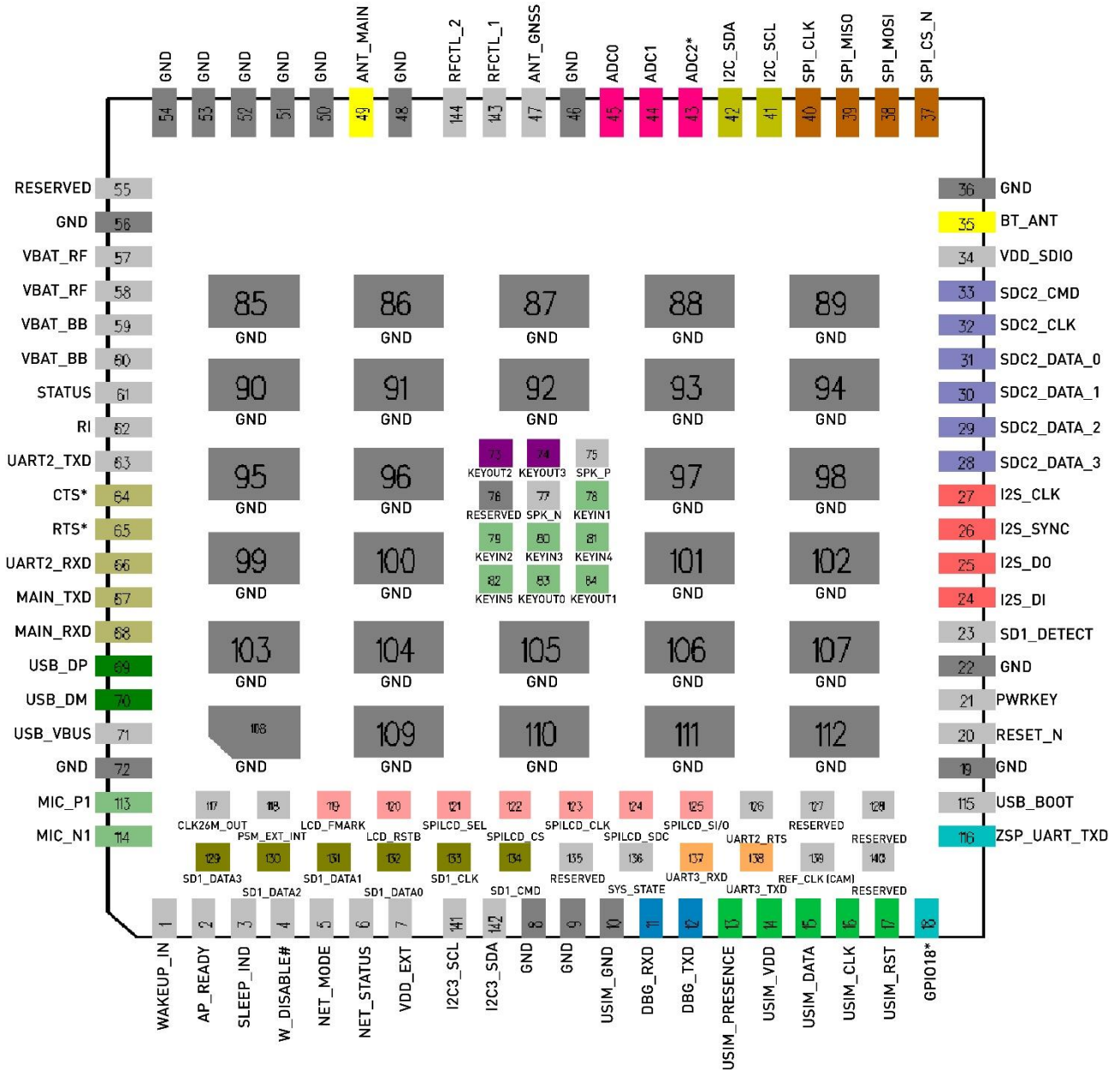

Figure 2 Pin Assignment

Note:

The pin name in the pin diagram is the actual wiring name inside the module.

3.3 PIN Description

The following table shows the definition of each pin in the SLM320 module.

Table 3 IO Parameter Definitions

Type	Description
IO	I/O two-way signal.
DI	Digital input signal.
DO	Digital output signal.
OD	Open drain output signal.
AI	Analog signal input
BOT	Two-way signal with leaky output.
PI	power input
PO	power output

Table 4 Pin Description

Pin number	Pin name	I/O	Electrical level	Description	Remark
1	WAKEUP_IN	I/O	VILnom=0V VIHnom=1.8V	External device wake up module If not, please suspend this pin	GPIO29
2	AP_READY	I/O	VILnom=0V VIHnom=1.8V	The module checks whether the host is sleeping If not, please suspend this pin	GPIO30
3	SLEEP_IND	I/O	VOLnom=0V VOHnom=1.8V	Systematic sleep indicator If not, please suspend this pin	GPIO8
4	W_DISABLE#	I/O	VILnom=0V VIHnom=1.8V	Modular flight mode control If not, please suspend this pin	GPIO31

5	NET_MODE	I/O	VOLnom=0V VOHnom=1.8V	Module network mode indication signal If not, please suspend this pin	GPIO13
6	NET_STATUS	I/O	VOLnom=0V VOHnom=1.8V	Module network status indicator If not, please suspend this pin	GPIO19
7	VDD_EXT	PO	1.8V	Module digital level, 1.8V output, 50mA load capacity If not, please suspend this pin	
8	GND	G		GND	
9	GND	G		GND	
10	USIM_GND	G		GND	
11	DBG_RXD	I	VILnom=0V VIHnom=1.8V	Debug serial port receiving If not, please suspend this pin	
12	DBG_TXD	O	VOLnom=0V VOHnom=1.8V	Debug serial port sending If not, please suspend this pin	
13	USIM_PRESEN CE	I	VILnom=0V VIHnom=1.8V	USIM card hot swap detection If not, please suspend this pin, Software shutdown detection function	
14	USIM_VDD	PO	1.8V/3.0V	USIM power supply	
15	USIM_DATA	I/O	1.8V/3.0V	USIM data signal line	
16	USIM_CLK	O	1.8V/3.0V	USIM clock signal line	
17	USIM_RST	O	1.8V/3.0V	USIM reset signal line	
18	GPIO18	IO	VILnom=0V VIHnom=1.8V	If not, please suspend this pin	The module is internally connected with UART2_ RTS, default NC

19	GND	G		GND
20	RESET_N	I	VILnom=0V VIHnom=1.8V	Module reset signal, low level valid
21	PWRKEY	I	VILnom=0V VIHnom=1.8V	Module power on / off signal Low level active
22	GND	G		GND
23	SD1_DETECT	I	VILnom=0V VIHnom=1.8V	SD card hot swap detection signal If not, please suspend this pin
24	PCM_IN(I2S_DI)	I	VILnom=0V VIHnom=1.8V	PCM data input If not, please suspend this pin
25	PCM_OUT(I2S_DO)	O	VOLnom=0V VOHnom=1.8V	PCM data output If not, please suspend this pin
26	PCM_SYNC(I2S_SYNC)	I/O	0V/1.8V	PCM data synchronization signal If not, please suspend this pin
27	PCM_CLK(I2S_CLK)	I/O	0V/1.8V	PCM clock signal If not, please suspend this pin
28	SDC2_DATA_3	I/O	1.8V/3.0V	SDC2_DATA_3 If not, please suspend this pin
29	SDC2_DATA_2	I/O	1.8V/3.0V	SDC2_DATA_2 If not, please suspend this pin
30	SDC2_DATA_1	I/O	1.8V/3.0V	SDC2_DATA_1 If not, please suspend this pin
31	SDC2_DATA_0	I/O	1.8V/3.0V	SDC2_DATA_0 If not, please suspend this pin
32	SDC2_CLK	O	1.8V/3.0V	SDC2_CLK If not, please suspend this pin
33	SDC2_CMD	O	1.8V/3.0V	SDC2_CMD If not, please suspend this pin
34	VDD_SDIO	PO	1.8V/3.0V	SD card pull-up power supply, power supply capacity 150mA

35	WIFI_ANT(BT_ANT)	I		WiFi / BT antenna If not, please suspend this pin	The module is internally connected with BT_ANT
36	GND	G		GND	
37	SPI_CS_N	O	VOLnom=0V VOHnom=1.8V	SPI chip selection signal If not, please suspend this pin	
38	SPI_MOSI	O	VOLnom=0V VOHnom=1.8V	SPI_MOSI If not, please suspend this pin	
39	SPI_MISO	I	VILnom=0V VIHnom=1.8V	SPI_MISO If not, please suspend this pin	
40	SPI_CLK	O	VOLnom=0V VOHnom=1.8V	SPI_CLK If not, please suspend this pin	
41	I2C_SCL	OD	VOLnom=0V VOHnom=1.8V	I2C interface clock signal If not, please suspend this pin	
42	I2C_SDA	BOT	0V/1.8V	I2C interface data signal If not, please suspend this pin	
43	ADC2*	AI		ADC interface 2 When in use, 1K in series, If not, please suspend this pin	
44	ADC1	AI		ADC interface 1 When in use, 1K in series, If not, please suspend this pin	
45	ADC0	AI		ADC interface 0 When in use, 1K in series, If not, please suspend this pin	
46	GND	G		GND	
47	ANT_GNSS			GPS antenna If not, please suspend this pin	
48	GND	G		GND	
49	ANT_MAIN	I/O		Main collector antenna	

50	GND	G		GND	
51	GND	G		GND	
52	GND	G		GND	
53	GND	G		GND	
54	GND	G		GND	
55	RESERVED			RESERVED	
56	GND	G		GND	
57	VBAT_RF	PI	Vmax=4.5V Vmin=3.2V Vnorm=3.6V	RF power input	Connected to Vbat
58	VBAT_RF	PI	Vmax=4.5V Vmin=3.2V Vnorm=3.6V	RF power input	Connected to Vbat
59	VBAT_BB	PI	Vmax=4.5V Vmin=3.2V Vnorm=3.6V	Baseband power input	Connected to Vbat
60	VBAT_BB	PI	Vmax=4.5V Vmin=3.2V Vnorm=3.6V	Baseband power input	Connected to Vbat
61	STATUS	O	VOLnom=0V VOHnom=1.8V	Reserved status indication interface If not, please suspend this pin	
62	RI*	O	VOLnom=0V VOHnom=1.8V	Module output ringing prompt If not, please suspend this pin	GPIO22
63	UART2_TXD	O	VOLnom=0V VOHnom=1.8V	Module sends data If not, please suspend this pin	UART2_TXD
64	CTS*	O	VOLnom=0V VOHnom=1.8V	Module clear send	UART1_CTS
65	RTS*	O	VOLnom=0V VOHnom=1.8V	Module request sending	UART1_RTS
66	UART_2_RXD	O	VOLnom=0V VOHnom=1.8V	The module receives data	UART_2_RXD
67	MAIN_TXD	O	VOLnom=0V VOHnom=1.8V	Module sends data If not, please suspend this pin	UART1_TXD, for at command
68	MAIN_RXD	I	VILnom=0V VIHnom=1.8V	The module receives data	UART1_RXD, for at

				If not, please suspend this pin	command
69	USB_DP	I/O		USB signal DP	
70	USB_DM	I/O		USB signal DM	
71	USB_VBUS	AI	Vnorm=5.0V	USB insertion detection signal	
72	GND	G		GND	
73	KEYOUT2	I		Keyboard matrix input signal If not, please suspend this pin	
74	KEYOUT3	I		Keyboard matrix input signal If not, please suspend this pin	
75	SPK_P	O		SPK_P If not, please suspend this pin	
76	RESERVED				
77	SPK_N	O		SPK_N If not, please suspend this pin	
78	KEYIN1	I	VILnom=0V VIHnom=1.8V	Keyboard matrix input signal If not, please suspend this pin	
79	KEYIN2	I	VILnom=0V VIHnom=1.8V	Keyboard matrix input signal If not, please suspend this pin	
80	KEYIN3	I	VILnom=0V VIHnom=1.8V	Keyboard matrix input signal If not, please suspend this pin	
81	KEYIN4	I	VILnom=0V VIHnom=1.8V	Keyboard matrix input signal If not, please suspend this pin	
82	KEYIN5	I	VILnom=0V VIHnom=1.8V	Keyboard matrix input signal If not, please suspend this pin	
83	KEYOUT0	O	VOLnom=0V VOHnom=1.8V	Keyboard matrix input signal	

				If not, please suspend this pin
84	KEYOUT1	O	VOLnom=0V VOHnom=1.8V	Keyboard matrix input signal If not, please suspend this pin
85-112	GND	G		GND
113	MIC_P1	I	VOLnom=0V VOHnom=1.8V	If not, please suspend this pin
114	MIC_N1	I	VOLnom=0V VOHnom=1.8V	If not, please suspend this pin
115	USB_BOOT	I	VILnom=0V VIHnom=1.8V	USB_BOOT And VDD_Ext short circuit into emergency download mode It can be reused as keyin0
116	NC(ZSP_UART_TXD)			Reserved pin, default NC The module is internally connected with ZSP_UART_TXD
117	CLK26M_OUT	O		CLK26M_OUT If not, please suspend this pin
118	NC(PSM_EXT_INT)			NC The module is internally connected with PSM_EXT_Int, default NC
119	LCD_FMARK	O	1.8V/3.0V	LCD_FMARK If not, please suspend this pin
120	LCD_RSTB	O	1.8V/3.0V	LCD_RSTB If not, please suspend this pin
121	SPILCD_SEL	O	1.8V/3.0V	SPILCD_SEL If not, please suspend this pin
122	SPILCD_CS	O	1.8V/3.0V	SPILCD_CS If not, please suspend this pin
123	SPILCD_CLK	O	1.8V/3.0V	SPILCD_CLK If not, please suspend this pin

124	SPILCD_SDC	O	1.8V/3.0V	SPILCD_SDC
125	SPILCD_SI/O	I/O	1.8V/3.0V	SPILCD_SI/O If not, please suspend this pin
126	UART2_RTS	I	VILnom=0V VIHnom=1.8V	Module clear send If not, please suspend this pin
127	RESERVED			RESERVED
128	RESERVED			RESERVED
129	SD1_DATA3	I/O	1.8V/3.0V	SD1_DATA3 If not, please suspend this pin
130	SD1_DATA2	I/O	1.8V/3.0V	SD1_DATA2 If not, please suspend this pin
131	SD1_DATA1	I/O	1.8V/3.0V	SD1_DATA1 If not, please suspend this pin
132	SD1_DATA0	I/O	1.8V/3.0V	SD1_DATA0 If not, please suspend this pin
133	SD1_CLK	O	1.8V/3.0V	SD1_CLK If not, please suspend this pin
134	SD1_CMD	O	1.8V/3.0V	SD1_CMD If not, please suspend this pin
135	RESERVED			RESERVED
136	SYS_STATE	I		Reserve data pin of camera If not used, suspend this pin
137	UART3_RXD	I	VILnom=0V VIHnom=1.8V	UART3_RXD, If not used, suspend this pin
138	UART3_TXD	O	VOLnom=0V VOHnom=1.8V	UART3_TXD, If not used, suspend this pin
139	REF_CLK	O		Reserve CLK of camera Configurable as GPIO If not used, suspend this pin
140*	RESERVED			RESERVED

141	I2C3_SCL	OD	VOLnom=0V VOHnom=1.8V	I2C3_SCL	
142	I2C3_SDA	BOT	0V/1.8V	I2C3_SDA	
143	RFCTL_1	O	VOLnom=0V VOHnom=1.8V	RFCTL_1 If not used, suspend this pin	The module is actually connected to rfctl 3
144	RFCTL_2	O	VOLnom=0V VOHnom=1.8V	RFCTL_2 If not used, suspend this pin	The module is actually connected to rfctl 4

Remark:

1. * Is a function under development;
2. The above interface functions are not supported at the same time, some pins are reusable functions, please pay attention when selecting!
3. See the documentation for SLM320 pin multiplexing **SLM320_GPIO unction multiplex**.

3.4 Power source

Table 5 Description of SLM320 module power interface.

Pin Name	I/O	Pin	Description
VBAT_RF	PI	57,58	Module power supply, 3.4~4.5V, nominal value 3.8
VBAT_BB	PI	59,60	Module power supply, 3.4~4.5V, nominal value 3.8
VDD_EXT	PO	7	Voltage output, 1.8V
GND	G	8,9,19,22,36,46,48,50-5 4,56,85-112	GND

3.4.1 Power Supply

SLM320 module is powered through VBAT pin. The power supply recommended reference design is shown in Figure 3

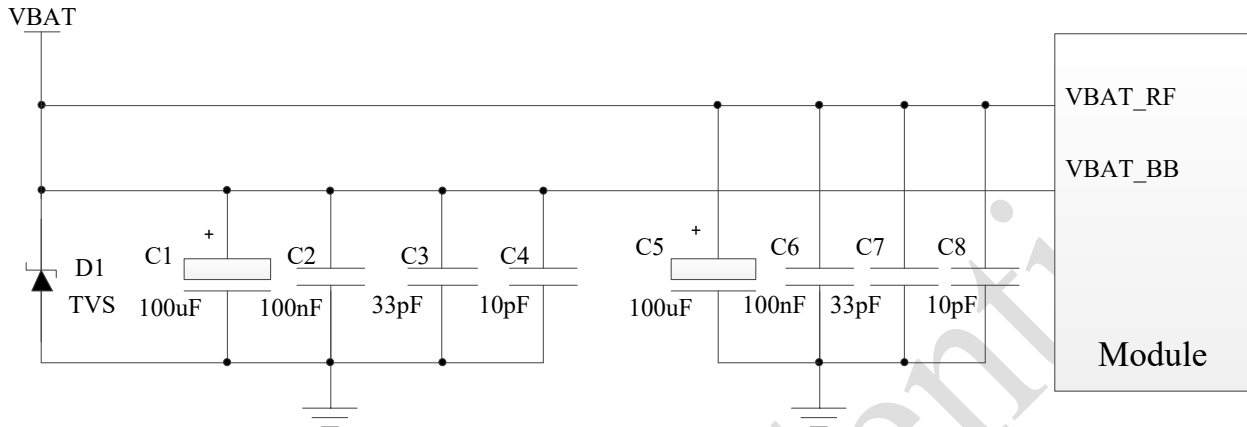

Figure 3 Module power supply circuit

3.4.2 Reduce voltage drop

SLM320 power supply range is from 3.2 V to 4.5 V, during data transmission or voice call, the ripple current up to 2A typically, due to GSM/GPRS emission burst (every 4.615ms), it may cause voltage drop. So the power supply for these pads must be able to provide sufficient current up to more than 2A. User needs to make sure that the input voltage will never drop below 3.3V.

Figure 4 shows the voltage drop during burst transmission under 2G network.

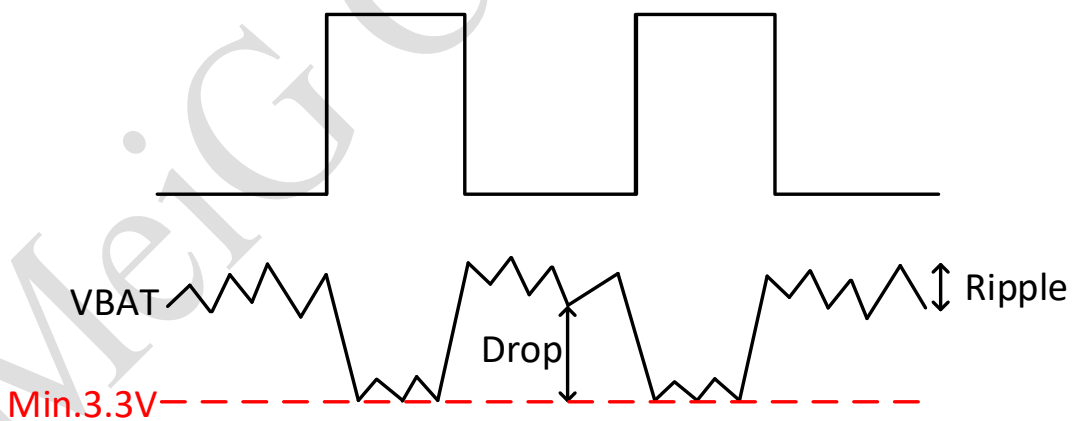

Figure 4 Burst transmission power requirements

To reduce voltage drop, a 100uF filter capacitor with low ESR is required. MLCC has the best ESR. It is recommended to add 3 ceramic capacitors (100nF, 33pF, 10pF) to VBAT_BB and VBAT_RF pins, and the capacitors should be placed close to VBAT pins. At the same time, in order to ensure better power supply performance, a TVS tube is added near the input end of the module VBAT to improve the module's electrostatic bearing capacity. When the external power supply is connected to the module, VBAT_BB and VBAT_RF need to adopt star wiring. VBAT_BB wire width shall not be less than 1mm, and VBAT_RF wire width shall not be less than 2mm. In principle, the longer the line in VBAT, the wider

the line.

3.4.3 Power Supply Reference Circuit

The design of the module power supply is very important, because the performance of the module depends largely on the power supply. The SLM320 must select a power source that provides at least 2A current capability. If the voltage difference between the input voltage and the module supply voltage is not very large, it is recommended to choose LDO as the supply. If there is a large voltage difference between the input and output voltages, DCDC is recommended as the power supply for the module.

The figure below is the reference design of + 5V power supply circuit. The LDO of MICREL Company is used in the design, and the model is MIC29302WU. The load current is 3.9V and the output voltage is 3.3A. Note that MIC29302WU has the requirement of minimum load current $\geq 10\text{mA}$.

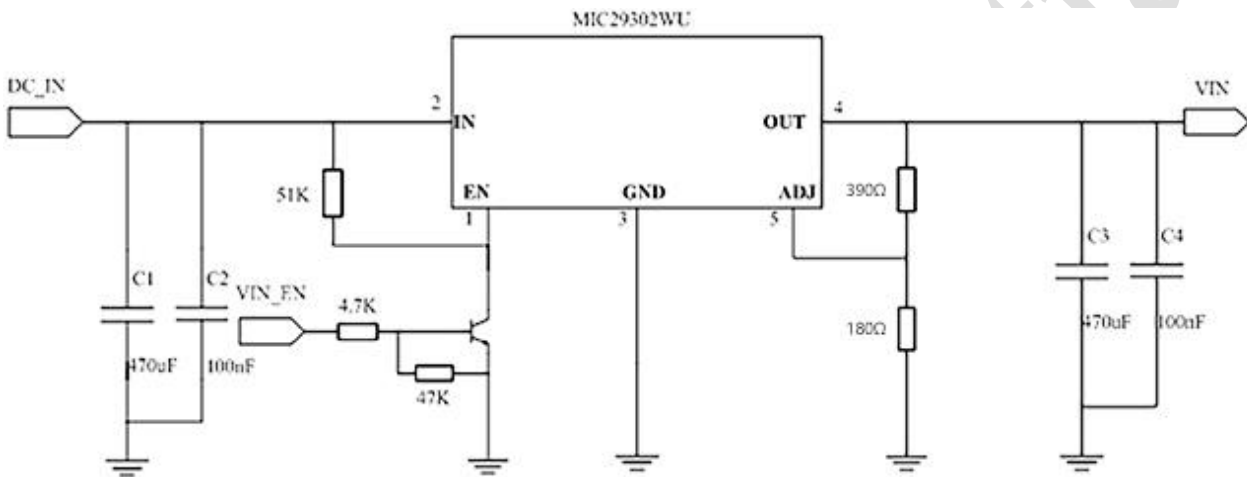

Figure 5 Reference design for power supply input

3.4.4 VDD_EXT voltage output

When the SLM320 module is normally powered on, there is a voltage output on Pin9_VDD_EXT, the output voltage is 1.8V, and the current load is 50mA. This output voltage can be used as an external pull-up source, such as a level reference, and the Pin status can be read to determine whether the module is switched on or not.

3.5 Start up

3.5.1 PWRKEY Pin boot

When the SLM320 module is in shut down mode, the module can be turned on by pulling down the PWRKEY for at least 1s. It is recommended to use an open set drive circuit to control PWRKEY pin. The reference circuit is as following:

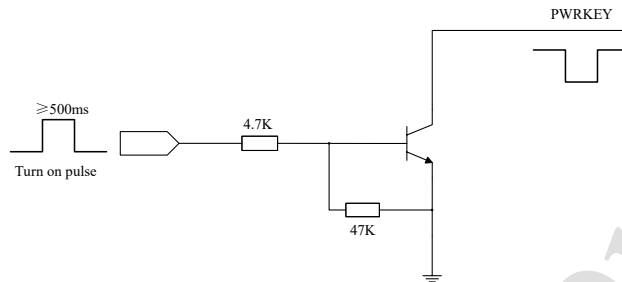

Figure 6 Open set drive reference boot circuit

Another way to control the PWRKEY pin is through a push button switch. A TVS is placed near the button for ESD protection. The reference circuit is shown as below:

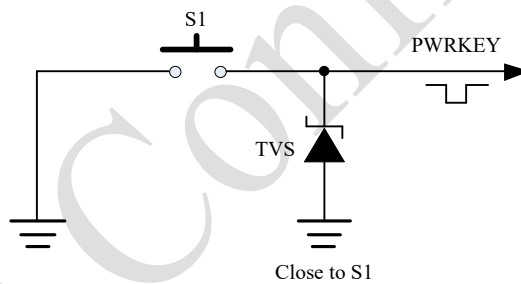

Figure 7 Button startup reference circuit

The boot sequence is shown in the figure below:

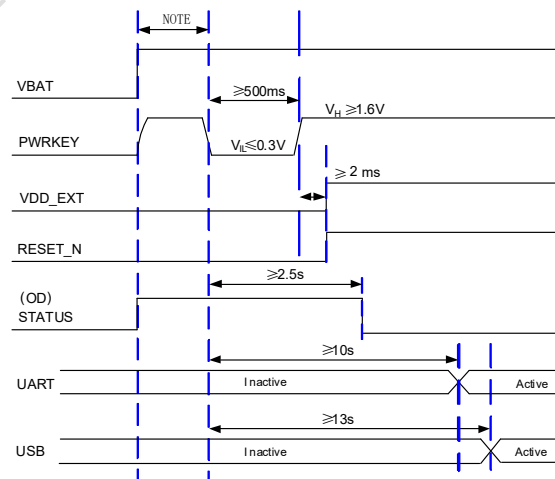

Figure8 Power-on sequence diagram

Note:

Before pulling down PWRKEY pin, VBAT voltage should be guaranteed to be stable. It is recommended that the time interval between powering up VBAT and pulling down PWRKEY pins should be no less than 30ms.

If the module needs to be powered on and started automatically, PWRKEY pin can be directly connected to the ground. The resistance value to GND should not exceed 4k at most. It is recommended to use 0R.

3.5.2 Power off**Table 6 Description of three shutdown modes of the module**

Shut down method	Shut of approach	Applicable scene
Low voltage shutdown	When VBAT voltage is too low or power is lost, the module will shut down	At this point, the module did not carry out the normal shutdown process, did not follow the process of logout from the base station
Hardware shutdown	Pull down PWRKEY(greater than 3.1s) and release	Normal_shutdown
ATshutdown	AT+CPOF	Soft power-off

Remark:

1. When the module is working normally, do not immediately cut off the power supply of the module to avoid damaging the flash data inside the module. It is strongly recommended to power off the module through the AT command before disconnecting the power.
2. When using the AT command to shut down, make sure that PWRKEY is in a high level state after the shutdown AT command is executed; otherwise, the module will start up again automatically after the shutdown is completed.

3.6 Reset Function

There are two SLM320 reset modes: hardware reset and AT command reset.

3.6.1 Hardware Reset

When the module is working, user can pull down the RESET_N pin by at least 150ms to reset the module. RESET_N signal is sensitive to interference, so it is suggested that the routing should be as short as possible and should be protected by GND traces.

The reference circuit is similar to the PWRKEY control circuit, and the customer can control the RESET_N pin by using an open set drive circuit or a button.

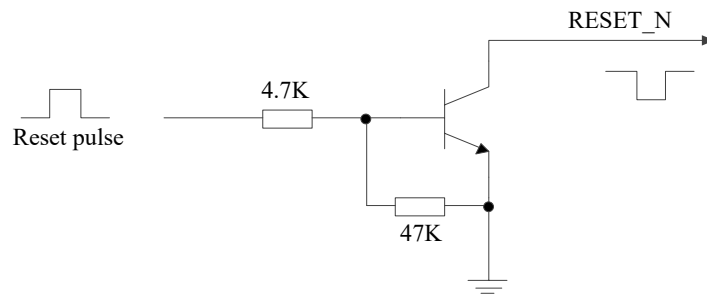

Figure 9 RESET_N reset the open set reference circuit

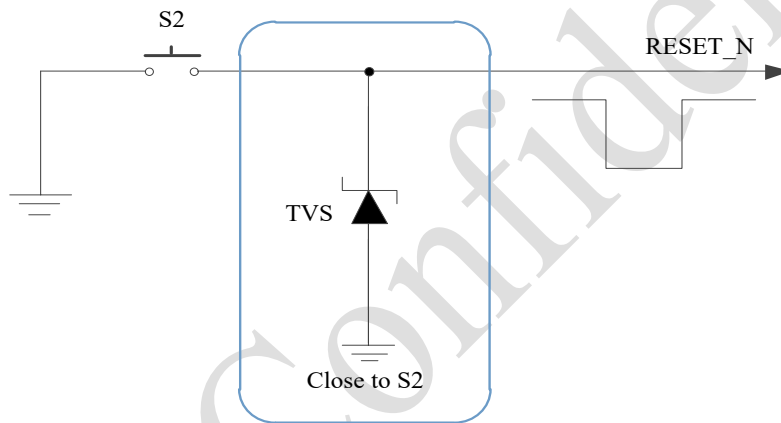

Figure 10 RESET_N reset button reference circuit

The reset sequence diagram is as follows:

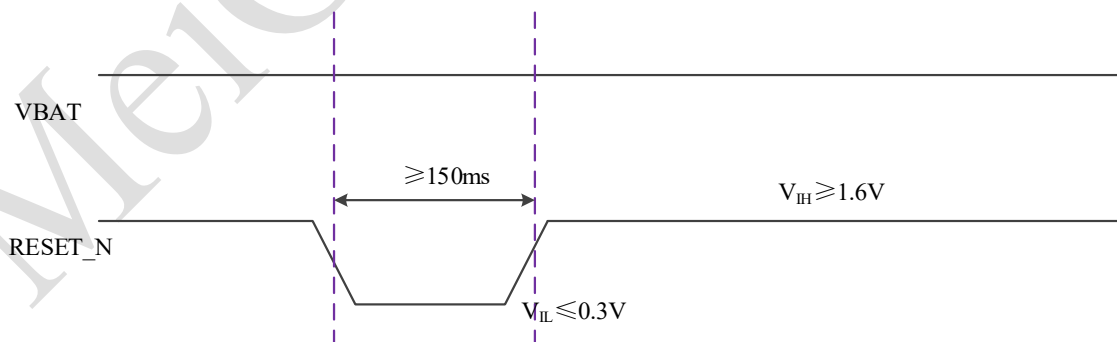

Figure 11 RESET_N reset sequence diagram

3.6.2 AT command Reset

Through SLM320 UART or USB AT port, enter **AT+TRB** command, make SLM320 reset and restart.

3.7 USIM/SIM Interface

SLM320 supports both 1.8V and 3.0V SIM cards.

Table 7 USIM/SIM interface description

Pin Name	I/O	Pin	Pin description
USIM_DATA	I/O	15	USIM/SIM data signal
USIM_CLK	O	16	USIM/SIM clock signal
USIM_RESET	O	17	USIM/SIM reset signal
USIM_VDD	O	14	USIM/SIM Power
USIM_PRESENCE	I	13	USIM/SIM Hot swap detection signal

SLM320 module supports USIM card hot-plugging function through SIM0_DET pin and supports high level detection. After SIM card is inserted in the figure, SIM0_DET pin is at high level. When SIM0_DET pin is at low level, no card is detected.

The SIM card hot swap function can be configured by the "AT+SIMHOTSWAP" command. The instructions of the AT command are shown in the following table:

Table 8 description of hot swap function setting of SIM card

AT Command	SIM card hot swap detection	Function declaration
AT+SIMHOTSWAP=1	Open	By default, the SIM card hot-plug detection function is on, and the module detects whether the SIM card is inserted through the USIM_PRESENCE pin status
AT+SIMHOTSWAP=0	Close	The SIM card hot-plug detection function is turned off. The SIM card will be read by the module when the machine is turned on. The USIM_PRESENCE status will not be detected

After the hot swap detection function of SIM card is turned on, when sim0_Det is high level. If the module detects that the SIM card is inserted, it will execute the SIM card initialization procedure. After reading the SIM card information, the module will register the network. When sim0_ When det is low power level, the module determines that the SIM card is pulled out, then the SIM card is not read. SIM0_Det is valid in high level by default and can be switched to low level by AT command.

The reference circuit is shown in the figure below, with SIM card hot swap function.

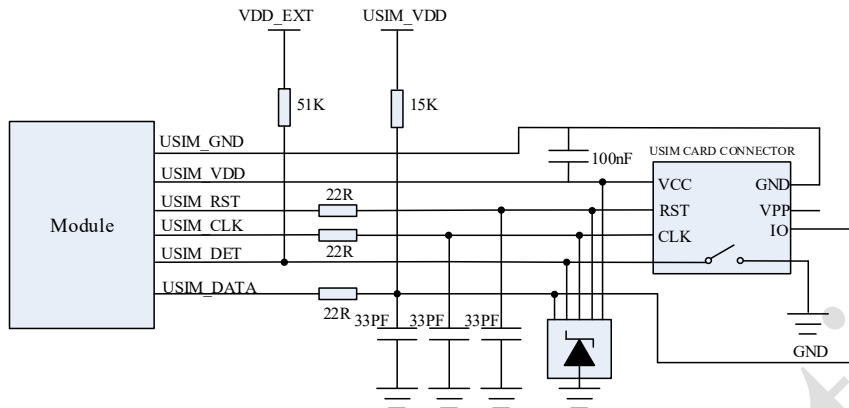

Figure 12 Reference design drawing of the booth with hot-plug function

If user does not need USIM card hot-plug detection, keep the USIM_DET pin open. The reference circuit is as follows:

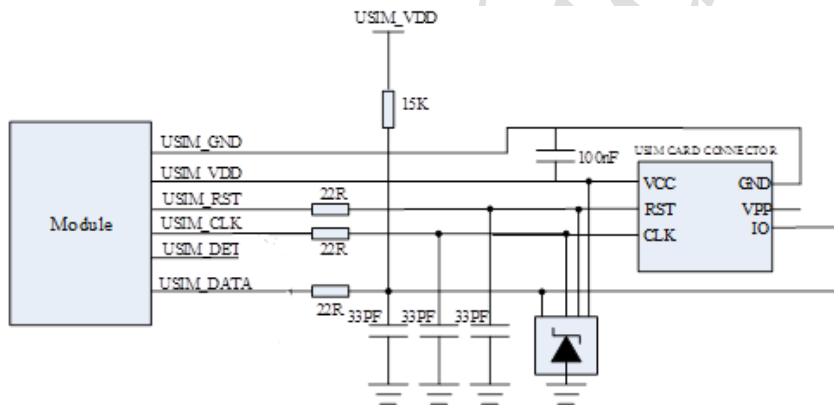

Figure 13 Reference design drawing of the booth without hot-plugging function

For USIM card interface, in order to ensure the good performance and reliability of USIM card, the following design principles are recommended in the circuit design:

- For SIM0_DAT, SIM0_CLK and SIM0_RST lines, a 22 Ω resistance used to suppress the spurious EMI, enhance ESD protection, and convenient debugging;
- In order to improve the antistatic ability, TVS are added on USIM_VDD, USIM_DATA, USIM_CLK and USIM_RST lines, ESD protection devices with parasitic capacitance no more than 15Pf;
- 33pF capacitors in parallel on USIM_VDD, USIM_DATA, USIM_CLK and USIM_RST lines are used to filter out GSM900 interference. The peripheral devices of the USIM card shall be placed as close as possible to the USIM booth;
- USIM booth is placed close to the module to ensure that the wiring length of USIM card signal line does not exceed 100mm;
- In order to prevent USIM_CLK signals from crosstalk with USIM_DATA, the two wires should not be too close together and an additional shielding should be added between the two wires;

3.8 USB port

The SLM320 provides a USB interface conforming to the USB 2.0 specification. This interface is used for AT command interaction, data transfer, software debugging and version upgrading, etc.

3.8.1 USB Pin Description

The SLM320 module provides a USB2.0 interface.

Table 9 USB interface

Pin Name	I/O	Pin	Description
VBUS	AI	71	USB Insert the test
USB_DP	I/O	69	USB Differential data +
USB_DM	I/O	70	USB Differential data -
GND	G	8,9,19,22,36,46,48,50-54,56,85-112	GND

3.8.2 USB Reference Circuit

The SLM320 module USB interface application reference circuit is shown in the figure below.

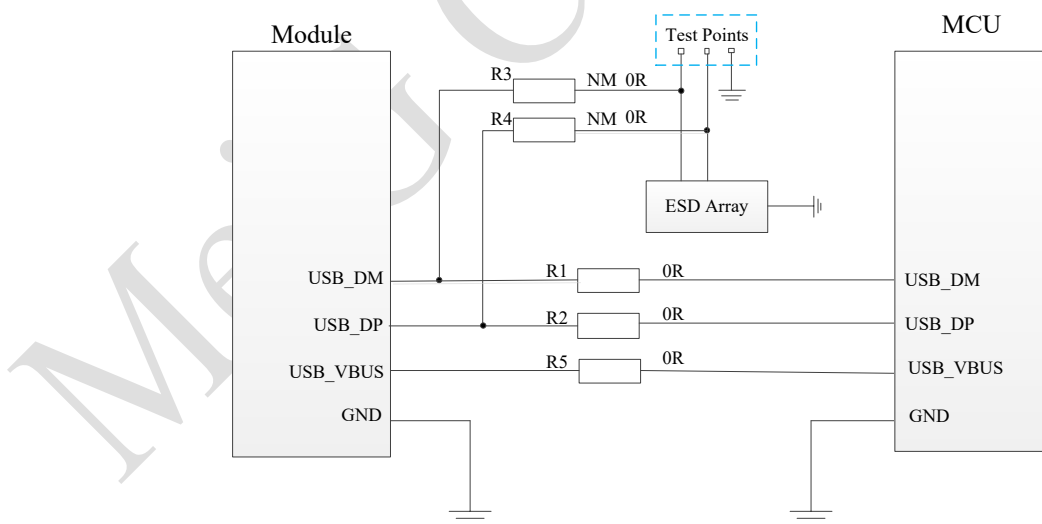

Figure 14 Refer to the design of the USB interface

In order to meet the signal integrity requirement of USB data line, R1/R2/R3/R4 resistors must be placed close to the module and between resistors close to each other. The branch connecting the test point must be as short as possible.

In USB interface circuit design, to ensure USB performance, the following principles are recommended in circuit design:

- The module USB_VBUS is not used to power the module, but to detect USB insertion and unplugging;
- In order to reduce the USB high speed data transmission of signal interference, in USB_DM USB_DP interface circuit and concatenated R1 and R2 can improve the accuracy of data transmission, 0 Ω R1 and R2 are recommended;
- In order to improve the antistatic performance of USB interface, ESD protective devices are recommended to be added to USB_DP and USB_DM interface circuits, and ESD devices with junction capacitance less than 2pF are recommended. USB ESD protection device should be placed as close as possible to USB interface;
- In order to ensure the USB work reliable, the design still need more consideration to the protection of USB, such as the Layout of the protection of the USB, need to do to USB_DP and USB_DM 90 Ω impedance control, strictly in accordance with the requirements of the differential line, as far as possible away from the interference signal;
- Do not use USB cable under crystal oscillator, oscillator, magnetic device and RF signal. It is recommended to use inner differential wiring and wrap the ground left, right, up and down.

3.9 Serial Port

SLM320 module has three serial ports: main serial port UART1, DEBUG serial port UART and download, and RADIO frequency calibration serial port UART2. The main features of the main and debug serial ports are described below.

- The main serial port supports 4800Bps, 9600bps, 19200Bps, 38400Bps, 57600bps, 115200Bps, 230400bps baud rate. The default baud rate is 115200bps for data transmission and AT command transmission.
- Debugging serial port support 115200BPS baud rate, for r & D debugging use.

Table 10 Main serial port pin description

Pin Name	I/O	Pin	Description
UART1_RING	DO	62	Module output ring prompt
UART2_TXD	DO	63	Module sends data
CTS	I	64	Module clear send
RTS	O	65	The module requests to send
MAIN_TXD	O	67	Module sends data
MAIN_RXD	I	68	The module receives data

Table 11 Description of debugging serial port pin

Pin Name	I/O	PIN	Description
DBG_RXD	I	11	Module receiving data
DBG_TXD	O	12	Module send data

Table 12 Serial port logic level

Parameter	Min value	Max value	Units
V _{IL}	-0.3	0.6	V
V _{IH}	1.2	2.0	V
V _{OL}	0	0.45	V
V _{OH}	1.35	1.8	V

The serial port level of SLM320 module is 1.8V. If the client host is 3.3V, the level shifter needs to be added in the serial port application. TI's TXB0104PWR is recommended. The following picture is a reference design:

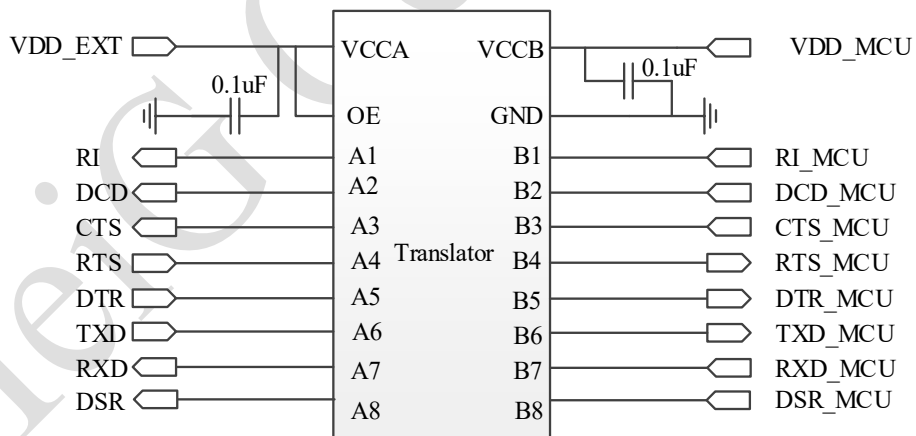

Figure 15 Level conversion chip reference circuit

Another level converter circuit is shown in the figure below. The input and output circuit design of the following dotted line section can refer to the solid line section, but pay attention to the connection direction. At the same time, this level conversion circuit is not suitable for applications with baud rate over 460Kbps.

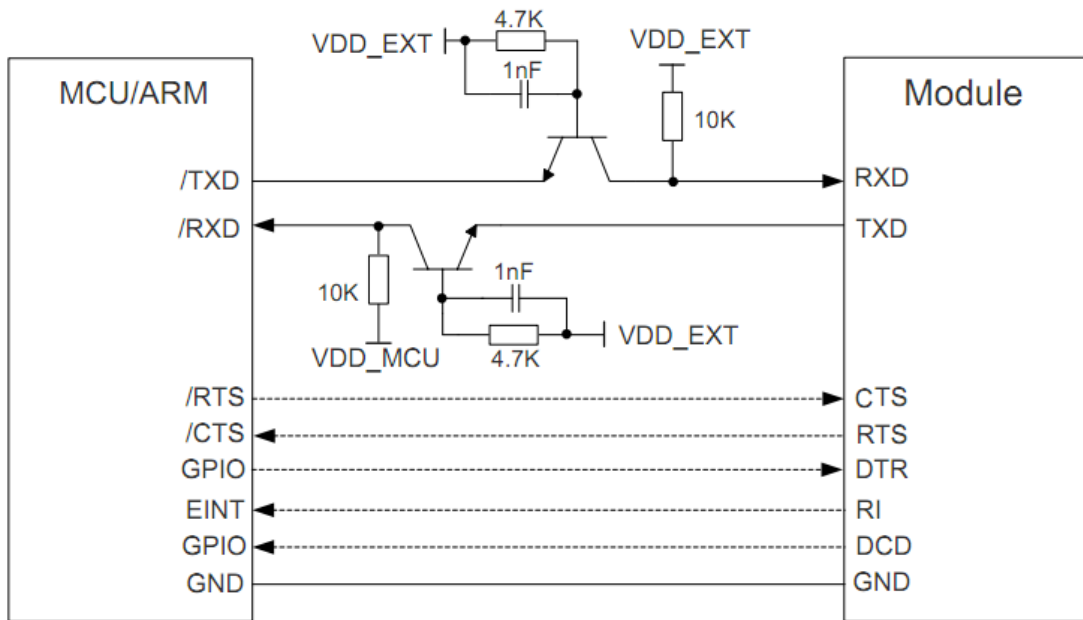

Figure 16 UART signal connection

Note: During design, it is recommended to reserve 0R resistance and parallel capacitor positions on the main serial port and debug serial port circuit, which can be added to the baseplate to prevent RF interference

3.10 Status indication

The status indicator pin is mainly used to drive the network status indicator. SLM320 module has net_MODE, NET_Status and status (reserved, default NC) are three network status pins. The following two tables describe pin definitions and logic level changes in different network states.

Table 13 Description of network indicator pin

Pin Name	I/O	Pin	Describe
NET_MODE	O	5	Module status indication
NET_STATUS	O	6	Module status indication
STATUS	O	61	Reserved

Table 14 Working status of network indicator pin

PIN Name	Pin working state	Working status indicated
NET_MODE	High level	Register LTE network status
	Low level	other
NET_STATUS	Slow flash (200ms high / 1800ms low)	Net searching status
	Slow flash (1800ms high / 200ms low)	position in readiness
	Flash (125ms high / 125ms low)	Data transmission mode
	High level	On the phone

The reference circuit is shown in the figure below:

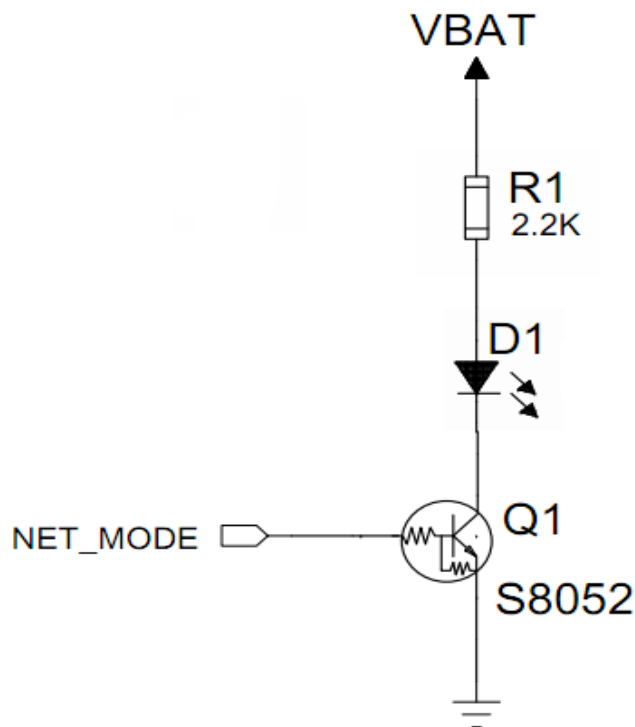

Figure 17 Reference design of network indication

Status is used to indicate the working status of the module, which is an open drain output pin. The customer can connect this pin to the GPIO or GPIO of the device band pull-up.

The LED indication circuit is shown in the figure below. When the module starts up normally, status defaults to high resistance state.

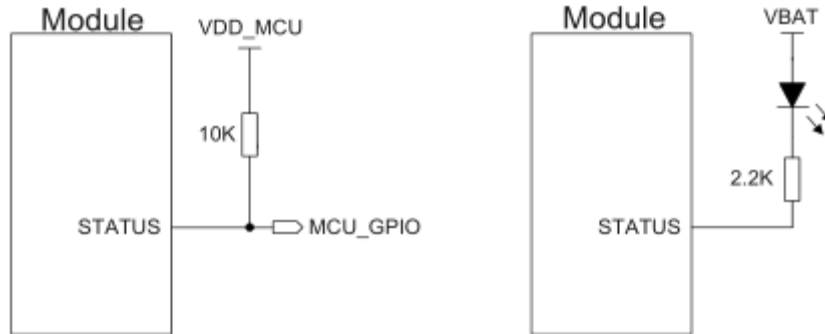

Figure 18 status reference circuit

3.11 Low Power Mode

3.11.1 Flight mode

Table 15 W_DISABLE pin descriptions

Pin Name	I/O	Pin	Description
W_DISABLE#	DI	4	Modular flight mode control

SLM320 module supports two ways to enter flight mode:

Table 16 Description of flight mode Settings

1	Hardware I/O interface button control	W_DISABLE# for high or hovering (default is pull-up) is normal mode, and low is flight mode
2	AT command control	AT+CFUN=4-- go into airplane mode AT+CFUN=1-- go into normal mode

3.11.2 Sleep mode

The module can activate sleep mode in the following ways:

At + CSCLK = 0: close deep sleep function.

At + CSCLK = 1: when setting, DTR pin needs to be high level, or wakeup pin needs to be low level to enter deep sleep mode;

After that, when the DTR is set high or the wakeup pin is set low, and no interrupt is generated (such as GPIO interrupt or serial port data transmission), the GSM part will automatically enter the deepsleep mode.

At + CSCLK =2: when no interrupt is generated, the GSM part will automatically enter deepsleep mode.

3.11.3 Ultra low power mode

Use the following AT instruction to put the module into ultra-low power mode (for power test).

```
AT^TRACECTRL=0,0;
```

```
AT^TRACECTRL=1,0;
```

```
AT+CSCLK=2;
```

3.12 ADC Function

SLM320 provides a Two-way 12-bit analog-digital conversion interface, and the ADC voltage range is 0-5V

Table 17 ADC pin description

Pin Name	I/O	Pin	Description
ADC0	I	45	Analog to digital converter interface 0
ADC1	I	44	Analog to digital converter interface 1
ADC2*	I	43	Analog to digital converter interface 2

Remark:

1. In the case that VBAT is not powered, the ADC interface cannot directly connect any input voltage.
2. It is recommended that the ADC pin be input with voltage divider circuit.
3. It is suggested that ADC should be wrapped when wiring, which can improve the accuracy of ADC voltage measurement.

3.13 USB_BOOT Port

SLM320 supports USB_BOOT. The client can shorten USB_BOOT and VDD_EXT before starting the module, and then the module will enter the forced download mode. In this mode, the module can be upgraded via USB interface.

Table 18 USB_BOOT pin definition

Pin Name	I/O	Pin	Description
USB_BOOT	I	115	Short connect USB_BOOT and VDD_EXT (V_IO18)
VDD_EXT	PO	7	before starting the module, and then the module will enter the forced download mode

4 GNSS Receiver

4.1 General Description

SLM320 use the independent GPS chip, includes a fully integrated global navigation satellite system solution that supports GPS, GLONASS, BeiDou. It supports standard NMEA-0183 protocol.

4.2 GNSS Performance

- Cold start time<40S
- Hot start time<5S
- Tracking sensitivity-160dBm
- Acquisition sensitivity-147dBm
- Position accuracy<3m

4.3 Layout Guidelines

The following layout guidelines should be taken into account in customers' designs.

- Maximize the distance among GNSS antenna, main antenna.
- Digital circuits such as (U) SIM card, USB interface, and camera module and display connector should be kept away from the antennas.
- Use ground vias around the GNSS trace and sensitive analog signal traces to provide coplanar isolation and protection.
- Keep 50Ω characteristic impedance for the ANT_GNSS trace.

4.4 Antenna connection

Customers can use active antenna and passive antenna. If customers use active antenna, please refer to the figure below, if passive antenna is used, please refer to the figure (Figure 19 RF reference circuit)

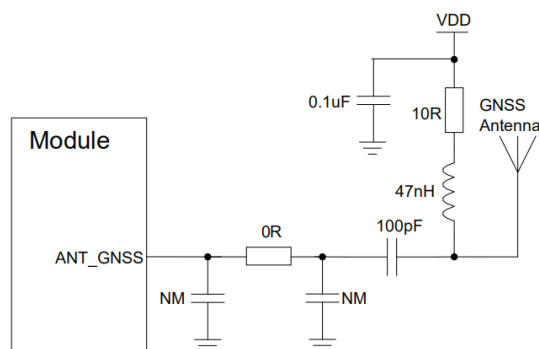

5 Antenna interface

SLM320 module design interface, there are three antennas, the antenna impedance 50Ω.

Table 19 Definition of pin of antenna interface

Pin Name	Pin Number	Description	I/O	Remark
ANT_MAIN	49	main antenna port	IO	50Ω impedance
BT_ANT	35	WIFI/BT antenna port	IO	50Ω impedance
ANT_GNSS	47	GPS antenna port	IO	50Ω impedance

5.1 Introduction to Antenna Interface

SLM320 provides three antenna pins: ANT_MAIN and ANT_WIFI/BT to improve the product's TDD-LTE/FDD-LTE, WIFI/BT transceiver performance. It is recommended to use with the module, RF connector match 50 Ω impedance of the antenna.

Note:

In order to ensure the communication capability of all frequency bands, please connect all antennas. It is recommended that applications carefully select RF wiring. RF wiring needs to be selected with minimal loss. RF wiring for RF loss requirements is recommended as follows:

- GSM900 <0.6dB
- DCS1800 <1.0dB
- TDD-LTE<1.2dB
- FDD-LTE<1.2dB
- WIFI/BT<1.2dB
- GNSS<1.0dB

5.2 Radio frequency reference circuit

The reference circuit for antenna connection of ANT_MAIN, ANT_WIFI/BT is shown in the figure below. In order to obtain better RF performance, the following four points should be paid attention to when designing schematic diagram and PCB layout:

1. Schematic design, near the module RF port reserved type matching circuit, capacitor default not attached;
2. Schematic design, redundant RF connectors between the RF port of the module and the antenna, used for certification test, RF connectors are not attached after mass production and delivery; (Reference: RF Connector -1P-H176);
3. Schematic design, type matching circuit is reserved near the antenna end, capacitor is not affixed

by default;

- PCB layout, Module RF port to the antenna between lines as short as possible, and need to plate factory for RF line do 50 Ω impedance control.

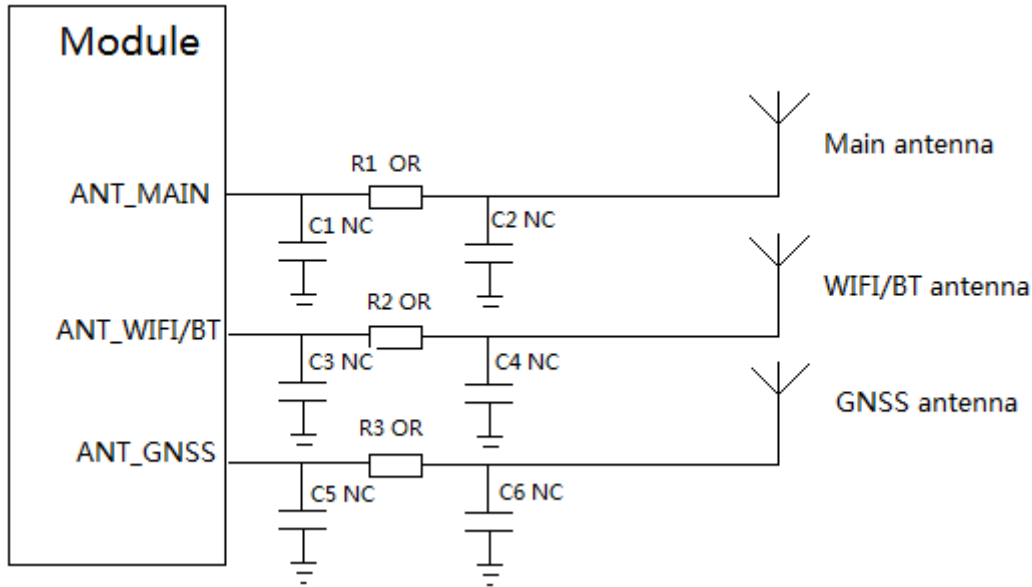

Figure 19 RF reference circuit

5.3 Installation of antenna

5.3.1 Antenna requirements

The requirements of antenna receiving antenna are shown in the following table:

Table 20 Antenna requirements

Type	Requirement
GSM/TDD-LTE/FDD-LTE	VSWR: < 2
	Gain (dBi): 1
	Maximum Inupt (W): 2W
	Input impedance (ohm): 50
	Polarization Type: vertical direction
	Cable insertion loss: < 1.5dB (GSM900/1800 ; LTE B1/B2/B3/B4/B5/B8/B34/B39)
	Cable insertion loss: < 2dB (LTE B7/B38/B40/B41)
WIFI/BT	VSWR: < 2

GNSS	Gain (dBi): 1
	Maximum Input (W): 0.1W
	Input impedance (ohm): 50
	Polarization Type: vertical direction
	Cable insertion loss: < 1.5dB
	VSWR: < 2
	Gain (dBi): 1
	Maximum input power (W): 0.1W
	Input impedance (ohm): 50
	Polarization type: vertical
	Cable insertion loss:< 1.5dB

5.3.2 RF output power

The RF output power of SLM320 is shown in the following table.

Table 21 SLM320 RF transmission power

Frequency	Max	Min
EGSM900	33dBm±2dB	5dBm±5dB
DCS1800	30dBm±2dB	0dBm±5dB
LTE-FDD B1	23dBm±2.7dB	<-39dBm
LTE-FDD B2	23dBm±2.7dB	<-39dBm
LTE-FDD B3	23dBm±2.7dB	<-39dBm
LTE-FDD B4	23dBm±2.7dB	<-39dBm
LTE-FDD B5	23dBm±2.7dB	<-39dBm
LTE-FDD B7	23dBm±2.7dB	<-39dBm
LTE-FDD B8	23dBm±2.7dB	<-39dBm
LTE-FDD B20	23dBm±2.7dB	<-39dBm

LTE-TDD B28	23dBm±2.7dB	<-39dBm
LTE-TDD B34	23dBm±2.7dB	<-39dBm
LTE-TDD B38	23dBm±2.7dB	<-39dBm
LTE-TDD B39	23dBm±2.7dB	<-39dBm
LTE-TDD B40	23dBm±2.7dB	<-39dBm
LTE-TDD B41	23dBm±2.7dB	<-39dBm

5.3.3 RF reception sensitivity

Table 22 SLM320 module RF reception sensitivity

Frequency	Reception sensitivity (typical value BW) -10M			
	Dominant set	Diversity	Dominant + Diversity	3GPP (Dominant + Diversity)
EGSM900	-108dBm	NA	NA	-102.4dBm
DCS1800	-108dBm	NA	NA	-102.4dBm
LTE-FDD B1	-97dBm	NA	NA	-96.3dBm
LTE-FDD B2	-97dBm	NA	NA	-94.3dBm
LTE-FDD B3	-97dBm	NA	NA	-93.3dBm
LTE-FDD B4	-97dBm	NA	NA	-96.3dBm
LTE-FDD B5	-98dBm	NA	NA	-94.3dBm
LTE-FDD B7	-97dBm	NA	NA	-94.3dBm
LTE-FDD B8	-98dBm	NA	NA	-93.3dBm
LTE-FDD B20	-98dBm	NA	NA	-93.3dBm
LTE-FDD B28	-98dBm	NA	NA	-94.8dBm
LTE-TDD B34	-97.5dBm	NA	NA	-96.3dBm
LTE-TDD B38	-97.5dBm	NA	NA	-96.3dBm
LTE-TDD B39	-97.5dBm	NA	NA	-96.3dBm
LTE-TDD B40	-97.5dBm	NA	NA	-96.3dBm

LTE-TDD B41 -97.5dBm NA NA -94.3dBm

Remark:

Other sub-model and frequency information will be reflected in subsequent versions of the document.

5.3.4 Working frequency**Table 23 SLM320 operating frequency**

3GPP Frequency band	UL	DL	Unit
EGSM900	880~915	925~960	MHz
DCS1800	1710~1785	1805~1880	MHz
LTE-FDD B1	1920~1980	2110~2170	MHz
LTE-FDD B2	1850~1910	1930~1990	MHz
LTE-FDD B3	1710~1785	1805~1880	MHz
LTE-FDD B4	1710~1755	2110~2155	MHz
LTE-FDD B5	824~849	869~894	MHz
LTE-FDD B7	2500~2570	2620~2690	MHz
LTE-FDD B8	880~915	925~960	MHz
LTE-FDD B20	832~862	791~821	MHz
LTE-FDD B28	703~748	758~803	MHz
LTE-TDD B34	2010~2025	2010~2025	MHz
LTE-TDD B38	2570~2620	2570~2620	MHz
LTE-TDD B39	1880~1920	1880~1920	MHz
LTE-TDD B40	2300~2400	2300~2400	MHz
LTE-TDD B41	2555~2655	2555~2655	MHz

WIFI/BT	2400-2483	2400~2483	MHZ
GPS	/	1575.42±1	MHZ
BDS	/	1559~1563	MHZ
Glonass	/	1597~1606	MHZ

MeiG Confidential

5.3.5 OTA Antenna requirements

Table 24 Antenna index requirements

Network Mode	Band	VSWR	Gain		Effi.	SAR	TRP (dBm)	TIS (dBm)
			Peak	Avg.				
GSM	850/900						26	<-102
	1800(DCS)						26	<-102
	1900(PCS)						26	<-102
TDD-LTE	Band34						19	<-94
	Band38						19	<-94
	Band39						19	<-94
	Band40						19	<-94
	Band41						19	<-94
FDD-LTE	Band1	<2.5:1	>0dBi	>-4dBi	>40%	<1.6W/Kg	19	<-94
	Band2						19	<-94
	Band3						19	<-94
	Band4						19	<-94
	Band5						19	<-94
	Band7						19	<-94
	Band8						19	<-94
	Band20						19	<-94
	Band28						19	<-94
WIFI	2400	<2.5:1	>0dBi	>-4dBi	>40%	<1.6W/Kg	/	<-80
BT	2400	<2.5:1	>0dBi	>-4dBi	>40%	<1.6W/Kg	3	<-82

6 Electrical characteristics

6.1 Absolute Maximum Ratings

Absolute maximum ratings refer to the maximum voltage range that the module supply voltage and digital and analog input/output interfaces can withstand. Work outside this range may cause damage to the product.

Table 25 Absolut Maximum Ratings

Parameters	Description	Min	Typical value	Max	Units
VBAT	Power supply	-0.3	3.6	5.5	V
GPIO	Digital I/O level supply voltage	-0.3	1.8	2.0	V
VBUS	USB Insert the test	-0.3	5.0	9.2	V

6.2 Ambient Temperature Range

The SLM320 module is recommended to operate at $-30\sim+75^{\circ}\text{C}$. It is suggested that temperature control measures should be considered at the application end under adverse environmental conditions. At the same time, the extended operating temperature range of the module is provided. When used at the extended temperature, the function is normal, and some RF indicators may deteriorate. It is also recommended that the module application terminal be stored at a certain temperature. Modules outside this range may not work properly or may be damaged.

6.3 Electrical Characteristics of Interface Working State

V_L : Logic low level

V_H : Logic high level

Table 26 The logic level of a normal digital IO signal

Signal	VL		VH		Unit
	Min	Max	Min	Max	
digital input	-0.3	0.6	1.2	2.0	V
digital output		0.45	1.35		V

Table 27 Electrical characteristics of power supply operating state

Parameters	I/O	Min	Model	Max	Unit
VBAT	I	3.4	3.8	4.5	V
VBUS	I	4.5	5.0	9.2	V
USIM_VDD	O	1.7/2.75	1.8/2.85	1.9/2.95	V

6.4 Module Power Consumption Range

Table 28 Power consumption

State of the module	Test Item	Test Case	Result (mA)	
Power off	Shutdown leakage current	Maintain normal voltage (3.8V) power supply in case of power failure	30uA	
		Insert the mobile card, the actual network standby, use the AT command to query the registration on the network, and record the average current of 10 minutes.	1.6	
Real network Sleep	Real network Sleep	Insert the unicom card, the actual network standby, use AT command to query and register the network, and record the 10-minute average current.	1.65	
		Insert the telecom card, the actual network standby, use AT command to query and register the network, and record the average current of 10 minutes.	1.75	
		GSM850 CH190 1) The tested module was powered on, and the data network was successfully registered; 2) Set the module to sleep state through AT instruction (USB is in suspended state); 3) Under the condition of no data transmission, the tested module maintained for 10 minutes and recorded the average current for 10 minutes.	1.6	
Dormant	GSM850	Module is powered on With no data transfer, the USB is in a suspended state	GSM850 CH128 1) The tested module was powered on, and the data network was successfully registered; 2) Set the module to sleep state through AT instruction (USB is in suspended state) 3) Under the condition of no data	1.6

transmission, the tested module maintained for 10 minutes and recorded the average current for 10 minutes.

GSM850 CH251

- 1) The tested module was powered on, and the data network was successfully registered;
- 2) Set the module to sleep state through AT instruction (USB is in suspended state); 1.5
- 3) Under the condition of no data transmission, the tested module maintained for 10 minutes and recorded the average current for 10 minutes.

GSM900 CH62

- 1) The tested module was powered on, and the data network was successfully registered;
- 2) Set the module to sleep state through AT instruction (USB is in suspended state); 1.4
- 3) Under the condition of no data transmission, the tested module maintained for 10 minutes and recorded the average current for 10 minutes.

GSM900 CH1

GSM900

- 1) The tested module was powered on, and the data network was successfully registered;
- 2) Set the module to sleep state through AT instruction (USB is in suspended state); 1.5
- 3) Under the condition of no data transmission, the tested module maintained for 10 minutes and recorded the average current for 10 minutes.

GSM900 CH124

- 1) The tested module was powered on, and the data network was successfully registered;
 - 2) Set the module to sleep state through AT instruction (USB is in suspended state); 1.4
 - 3) Under the condition of no data transmission, the tested module maintained for 10 minutes and recorded the average current for 10 minutes.
-

	DCS CH698	
	1) The tested module was powered on, and the data network was successfully registered;	
	2) Set the module to sleep state through AT instruction (USB is in suspended state);	1.3
	3) Under the condition of no data transmission, the tested module maintained for 10 minutes and recorded the average current for 10 minutes.	
	DCS CH512	
	1) The tested module was powered on, and the data network was successfully registered;	
DCS	2) Set the module to sleep state through AT instruction (USB is in suspended state);	1.4
	3) Under the condition of no data transmission, the tested module maintained for 10 minutes and recorded the average current for 10 minutes.	
	DCS CH885	
	1) The tested module was powered on, and the data network was successfully registered;	
	2) Set the module to sleep state through AT instruction (USB is in suspended state);	1.4
	3) Under the condition of no data transmission, the tested module maintained for 10 minutes and recorded the average current for 10 minutes.	
	PCS CH661	
	1) The tested module was powered on, and the data network was successfully registered;	
	2) Set the module to sleep state through AT instruction (USB is in suspended state);	1.4
PCS	3) Under the condition of no data transmission, the tested module maintained for 10 minutes and recorded the average current for 10 minutes.	
	PCS CH512	
	1) The tested module was powered on, and the data network was successfully registered;	1.6

- 2) Set the module to sleep state through AT instruction (USB is in suspended state);
- 3) Under the condition of no data transmission, the tested module maintained for 10 minutes and recorded the average current for 10 minutes.

PCS CH810

- 1) The tested module was powered on, and the data network was successfully registered;
- 2) Set the module to sleep state through AT instruction (USB is in suspended state); 1.6
- 3) Under the condition of no data transmission, the tested module maintained for 10 minutes and recorded the average current for 10 minutes.

Band1 CH18300

- 1) The tested module was powered on, and the data network was successfully registered;
- 2) Set the module to sleep state through AT instruction (USB is in suspended state); 1.5
- 3) Under the condition of no data transmission, the tested module maintained for 10 minutes and recorded the average current for 10 minutes.

Band1 CH18050

- 1) The tested module was powered on, and the data network was successfully registered;
- 2) Set the module to sleep state through AT instruction (USB is in suspended state); 1.6
- 3) Under the condition of no data transmission, the tested module maintained for 10 minutes and recorded the average current for 10 minutes.

Band1 CH18550

- 1) The tested module was powered on, and the data network was successfully registered; 1.6
- 2) Set the module to sleep state through AT instruction (USB is in suspended state);
- 3) Under the condition of no data

FDD
 The module is powered on, and the DRX monitoring period of the idle state on the network is 1.28s. With no data transfer, the USB is in a suspended state.

transmission, the tested module maintained for 10 minutes and recorded the average current for 10 minutes.

Band2 CH18650

- 1) The tested module was powered on, and the data network was successfully registered;
 - 2) Set the module to sleep state through AT instruction (USB is in suspended state); 1.3
 - 3) Under the condition of no data transmission, the tested module maintained for 10 minutes and recorded the average current for 10 minutes.
-

Band2 CH18900

- 1) The tested module was powered on, and the data network was successfully registered;
 - 2) Set the module to sleep state through AT instruction (USB is in suspended state); 1.2
 - 3) Under the condition of no data transmission, the tested module maintained for 10 minutes and recorded the average current for 10 minutes.
-

Band2 CH19150

- 1) The tested module was powered on, and the data network was successfully registered;
 - 2) Set the module to sleep state through AT instruction (USB is in suspended state); 1.2
 - 3) Under the condition of no data transmission, the tested module maintained for 10 minutes and recorded the average current for 10 minutes.
-

Band3 CH19575

- 1) The tested module was powered on, and the data network was successfully registered;
 - 2) Set the module to sleep state through AT instruction (USB is in suspended state); 1.3
 - 3) Under the condition of no data transmission, the tested module maintained for 10 minutes and recorded the average current for 10 minutes.
-

Band3 CH19250

- 1) The tested module was powered on, and the data network was successfully registered;
 - 2) Set the module to sleep state through AT instruction (USB is in suspended state); 1.2
 - 3) Under the condition of no data transmission, the tested module maintained for 10 minutes and recorded the average current for 10 minutes.
-

Band3 CH19900

- 1) The tested module was powered on, and the data network was successfully registered;
 - 2) Set the module to sleep state through AT instruction (USB is in suspended state); 1.2
 - 3) Under the condition of no data transmission, the tested module maintained for 10 minutes and recorded the average current for 10 minutes.
-

Band4 CH20000

- 1) The tested module was powered on, and the data network was successfully registered;
 - 2) Set the module to sleep state through AT instruction (USB is in suspended state); 1.3
 - 3) Under the condition of no data transmission, the tested module maintained for 10 minutes and recorded the average current for 10 minutes.
-

Band4 CH20175

- 1) The tested module was powered on, and the data network was successfully registered;
 - 2) Set the module to sleep state through AT instruction (USB is in suspended state); 1.3
 - 3) Under the condition of no data transmission, the tested module maintained for 10 minutes and recorded the average current for 10 minutes.
-

Band4 CH20375

- 1) The tested module was powered on, and the data network was successfully registered; 1.3
-

2) Set the module to sleep state through AT instruction (USB is in suspended state);

3) Under the condition of no data transmission, the tested module maintained for 10 minutes and recorded the average current for 10 minutes.

Band5 CH20525

1) The tested module was powered on, and the data network was successfully registered;

2) Set the module to sleep state through AT instruction (USB is in suspended state);

1.4

3) Under the condition of no data transmission, the tested module maintained for 10 minutes and recorded the average current for 10 minutes.

Band5 CH20450

1) The tested module was powered on, and the data network was successfully registered;

2) Set the module to sleep state through AT instruction (USB is in suspended state);

1.5

3) Under the condition of no data transmission, the tested module maintained for 10 minutes and recorded the average current for 10 minutes.

Band5 CH20600

1) The tested module was powered on, and the data network was successfully registered;

2) Set the module to sleep state through AT instruction (USB is in suspended state);

1.4

3) Under the condition of no data transmission, the tested module maintained for 10 minutes and recorded the average current for 10 minutes.

Band8 CH21625

1) The tested module was powered on, and the data network was successfully registered;

2) Set the module to sleep state through AT instruction (USB is in suspended state);

1.5

3) Under the condition of no data

transmission, the tested module maintained for 10 minutes and recorded the average current for 10 minutes.

Band8 CH21500

- 1) The tested module was powered on, and the data network was successfully registered;
- 2) Set the module to sleep state through AT instruction (USB is in suspended state); 1.5
- 3) Under the condition of no data transmission, the tested module maintained for 10 minutes and recorded the average current for 10 minutes.

Band8 CH21750

- 1) The tested module was powered on, and the data network was successfully registered;
- 2) Set the module to sleep state through AT instruction (USB is in suspended state); 1.4
- 3) Under the condition of no data transmission, the tested module maintained for 10 minutes and recorded the average current for 10 minutes.

Band40 CH39150

- 1) The tested module was powered on, and the data network was successfully registered;
- 2) Set the module to sleep state through AT instruction (USB is in suspended state); 1.6
- 3) Under the condition of no data transmission, the tested module maintained for 10 minutes and recorded the average current for 10 minutes.

TDD

The module is powered on, and the DRX monitoring period of the idle state on the network is 1.28s. With no data transfer, the USB is in a suspended state.

Band40 CH38700

- 1) The tested module was powered on, and the data network was successfully registered;
- 2) Set the module to sleep state through AT instruction (USB is in suspended state); 1.5
- 3) Under the condition of no data transmission, the tested module maintained for 10 minutes and recorded the average current for 10 minutes.

			<p>Band40 CH39600</p> <p>1) The tested module was powered on, and the data network was successfully registered;</p> <p>2) Set the module to sleep state through AT instruction (USB is in suspended state);</p> <p>3) Under the condition of no data transmission, the tested module maintained for 10 minutes and recorded the average current for 10 minutes.</p>	1.5
			<p>Band41 CH40620</p> <p>1) The tested module was powered on, and the data network was successfully registered;</p> <p>2) Set the module to sleep state through AT instruction (USB is in suspended state);</p> <p>3) Under the condition of no data transmission, the tested module maintained for 10 minutes and recorded the average current for 10 minutes.</p>	1.5
			<p>Band41 CH40290</p> <p>1) The tested module was powered on, and the data network was successfully registered;</p> <p>2) Set the module to sleep state through AT instruction (USB is in suspended state);</p> <p>3) Under the condition of no data transmission, the tested module maintained for 10 minutes and recorded the average current for 10 minutes.</p>	1.5
			<p>Band41 CH41190</p> <p>1) The tested module was powered on, and the data network was successfully registered;</p> <p>2) Set the module to sleep state through AT instruction (USB is in suspended state);</p> <p>3) Under the condition of no data transmission, the tested module maintained for 10 minutes and recorded the average current for 10 minutes.</p>	1.5
standby	FDD	The module is powered on, and the DRX monitoring	<p>Band1 CH18300</p> <p>Under the condition of no data transmission, the tested module maintained for 10 minutes and recorded</p>	38.39

period of the idle state on the network is 1.28s	the average current for 10 minutes.	
With no data transfer, USB is active	Band1 CH18050 Under the condition of no data transmission, the tested module maintained for 10 minutes and recorded the average current for 10 minutes.	37.86
	Band1 CH118550 Under the condition of no data transmission, the tested module maintained for 10 minutes and recorded the average current for 10 minutes.	38.56
	Band2 CH18650 Under the condition of no data transmission, the tested module maintained for 10 minutes and recorded the average current for 10 minutes.	37.39
	Band2 CH18900 Under the condition of no data transmission, the tested module maintained for 10 minutes and recorded the average current for 10 minutes.	37.86
	Band2 CH19150 Under the condition of no data transmission, the tested module maintained for 10 minutes and recorded the average current for 10 minutes.	38.86
	Band3 CH19575 Under the condition of no data transmission, the tested module maintained for 10 minutes and recorded the average current for 10 minutes.	38.57
	Band3 CH19250 Under the condition of no data transmission, the tested module maintained for 10 minutes and recorded the average current for 10 minutes.	36.99
	Band3 CH19900 Under the condition of no data transmission, the tested module maintained for 10 minutes and recorded the average current for 10 minutes.	37.41
	Band4 CH20175 Under the condition of no data transmission, the tested module maintained for 10 minutes and recorded the average current for 10 minutes.	39.5

		Band4 CH20375 Under the condition of no data transmission, the tested module maintained for 10 minutes and recorded the average current for 10 minutes.	38.59
		Band5 CH20525 Under the condition of no data transmission, the tested module maintained for 10 minutes and recorded the average current for 10 minutes.	37.46
		Band5 CH20600 Under the condition of no data transmission, the tested module maintained for 10 minutes and recorded the average current for 10 minutes.	38.83
		Band5 CH20450 Under the condition of no data transmission, the tested module maintained for 10 minutes and recorded the average current for 10 minutes.	37.32
		Band5 CH20525 Under the condition of no data transmission, the tested module maintained for 10 minutes and recorded the average current for 10 minutes.	37.46
		Band8 CH21750 Under the condition of no data transmission, the tested module maintained for 10 minutes and recorded the average current for 10 minutes.	39.3
		Band8 CH21625 Under the condition of no data transmission, the tested module maintained for 10 minutes and recorded the average current for 10 minutes.	37.59
		Band8 CH21500 Under the condition of no data transmission, the tested module maintained for 10 minutes and recorded the average current for 10 minutes.	37.88
TDD	The module is powered on, and the DRX monitoring period of the idle state on the network is 1.28s	Band40 CH39150 Under the condition of no data transmission, the tested module maintained for 10 minutes and recorded the average current for 10 minutes.	38.58
		Band40 CH39150 Under the condition of no data transmission, the tested module	38.94

	With no data transfer, the USB is in a suspended state	maintained for 10 minutes and recorded the average current for 10 minutes.	
		Band40 CH38700	
		Under the condition of no data transmission, the tested module maintained for 10 minutes and recorded the average current for 10 minutes.	39.77
		Band40 CH39600	
		Under the condition of no data transmission, the tested module maintained for 10 minutes and recorded the average current for 10 minutes.	37.89
		Band41 CH40620	
		Under the condition of no data transmission, the tested module maintained for 10 minutes and recorded the average current for 10 minutes.	35.3
		Band41 CH40209	
		Under the condition of no data transmission, the tested module maintained for 10 minutes and recorded the average current for 10 minutes.	37.49
		Band41 CH41190	
		Under the condition of no data transmission, the tested module maintained for 10 minutes and recorded the average current for 10 minutes.	38.26
	Real network data sleep	Unicom/Mobile Keep the data connection sending 256-byte packets back to the server every 5 minutes	
		Band1 0dBm	
		The tested module carries out data transmission and maintains for 5 minutes, and records the average current for 5 minutes	183.52
		Band1 10dBm	
		The tested module carries out data transmission and maintains for 5 minutes, and records the average current for 5 minutes	227.24
		Band1 23dBm CH18300	
		The tested module carries out data transmission and maintains for 5 minutes, and records the average current for 5 minutes	525.95
		Band1 23dBm CH18050	
		The tested module carries out data	590.36
Data transmission	FDD	1) Room temperature; 2) Dc power supply is used to supply the module, and the voltage is set at 3.8V;	

transmission and maintains for 5 minutes,
and records the average current for 5
minutes

Band1 23dBm CH18550

The tested module carries out data
transmission and maintains for 5 minutes, 624.43
and records the average current for 5
minutes

Band2 0dBm

The tested module carries out data
transmission and maintains for 5 minutes, 194.1
and records the average current for 5
minutes

Band2 10dBm

The tested module carries out data
transmission and maintains for 5 minutes, 258.21
and records the average current for 5
minutes

Band2 23dBm CH18065

The tested module carries out data
transmission and maintains for 5 minutes, 680.21
and records the average current for 5
minutes

Band2 23dBm CH18900

The tested module carries out data
transmission and maintains for 5 minutes, 675.64
and records the average current for 5
minutes

Band2 23dBm CH19150

The tested module carries out data
transmission and maintains for 5 minutes, 674.55
and records the average current for 5
minutes

Band3 0dBm

The tested module carries out data
transmission and maintains for 5 minutes, 194.1
and records the average current for 5
minutes

Band3 10dBm

The tested module carries out data
transmission and maintains for 5 minutes, 258.21
and records the average current for 5
minutes

Band3 23dBm CH19575

The tested module carries out data
transmission and maintains for 5 minutes, 650.21
and records the average current for 5
minutes

Band3 23dBm CH19250
The tested module carries out data transmission and maintains for 5 minutes, 645.64 and records the average current for 5 minutes

Band3 23dBm CH19900
The tested module carries out data transmission and maintains for 5 minutes, 634.5 and records the average current for 5 minutes

Band4 0dBm
The tested module carries out data transmission and maintains for 5 minutes, 194.1 and records the average current for 5 minutes

Band4 10dBm
The tested module carries out data transmission and maintains for 5 minutes, 256.21 and records the average current for 5 minutes

Band4 23dBm CH20000
The tested module carries out data transmission and maintains for 5 minutes, 650.21 and records the average current for 5 minutes

Band4 23dBm CH20175
The tested module carries out data transmission and maintains for 5 minutes, 649.60 and records the average current for 5 minutes

Band4 23dBm CH20350
The tested module carries out data transmission and maintains for 5 minutes, 635.5 and records the average current for 5 minutes

Band5 0dBm
The tested module carries out data transmission and maintains for 5 minutes, 162.35 and records the average current for 5 minutes

Band5 10dBm
The tested module carries out data transmission and maintains for 5 minutes, 209.25 and records the average current for 5 minutes

Band5 23dBm CH20525
The tested module carries out data transmission and maintains for 5 minutes, 543.21

and records the average current for 5 minutes

Band5 23dBm CH20450

The tested module carries out data transmission and maintains for 5 minutes, 558.57 and records the average current for 5 minutes

Band5 23dBm CH20600

The tested module carries out data transmission and maintains for 5 minutes, 581.79 and records the average current for 5 minutes

Band7 0dBm

The tested module carries out data transmission and maintains for 5 minutes, 174.21 and records the average current for 5 minutes

Band7 10dBm

The tested module carries out data transmission and maintains for 5 minutes, 210.1 and records the average current for 5 minutes

Band7 23dBm CH20800

The tested module carries out data transmission and maintains for 5 minutes, 690 and records the average current for 5 minutes

Band7 23dBm CH21100

The tested module carries out data transmission and maintains for 5 minutes, 700 and records the average current for 5 minutes

Band7 23dBm CH21400

The tested module carries out data transmission and maintains for 5 minutes, 710.5 and records the average current for 5 minutes

Band8 0dBm

The tested module carries out data transmission and maintains for 5 minutes, 174.21 and records the average current for 5 minutes

Band8 10dBm

The tested module carries out data transmission and maintains for 5 minutes, 214.3 and records the average current for 5 minutes

Band8 23dBm CH21625
The tested module carries out data transmission and maintains for 5 minutes, 561.18 and records the average current for 5 minutes

Band8 23dBm CH21500
The tested module carries out data transmission and maintains for 5 minutes, 576.91 and records the average current for 5 minutes

Band8 23dBm CH21750
The tested module carries out data transmission and maintains for 5 minutes, 579.38 and records the average current for 5 minutes

Band20 0dBm
The tested module carries out data transmission and maintains for 5 minutes, 175.4 and records the average current for 5 minutes

Band20 10dBm
The tested module carries out data transmission and maintains for 5 minutes, 215.6 and records the average current for 5 minutes

Band20 23dBm CH24200
The tested module carries out data transmission and maintains for 5 minutes, 567.8 and records the average current for 5 minutes

Band20 23dBm CH24300
The tested module carries out data transmission and maintains for 5 minutes, 580.2 and records the average current for 5 minutes

Band20 23dBm CH24400
The tested module carries out data transmission and maintains for 5 minutes, 579.38 and records the average current for 5 minutes

Band40 0dBm
The tested module carries out data transmission and maintains for 5 minutes, 388.39 and records the average current for 5 minutes

Band40 10dBm
The tested module carries out data transmission and maintains for 5 minutes, 165.22

TDD

		and records the average current for 5 minutes	
		Band40 23dBm CH39150 The tested module carries out data transmission and maintains for 5 minutes, and records the average current for 5 minutes	310.14
		Band40 23dBm CH38700 The tested module carries out data transmission and maintains for 5 minutes, and records the average current for 5 minutes	311.99
		Band40 23dBm CH39600 The tested module carries out data transmission and maintains for 5 minutes, and records the average current for 5 minutes	319.10
		Band41 0dBm The tested module carries out data transmission and maintains for 5 minutes, and records the average current for 5 minutes	158.2
		Band41 10dBm The tested module carries out data transmission and maintains for 5 minutes, and records the average current for 5 minutes	187.4
		Band41 23dBm CH40620 The tested module carries out data transmission and maintains for 5 minutes, and records the average current for 5 minutes	388.3
		Band41 23dBm CH40290 The tested module carries out data transmission and maintains for 5 minutes, and records the average current for 5 minutes	354.48
		Band41 23dBm CH41190 The tested module carries out data transmission and maintains for 5 minutes, and records the average current for 5 minutes	378.43
Power off	Shutdown leakage current	Maintain normal voltage (3.8V) power supply in case of power failure	30uA
Dormant	Real network Sleep	Insert the mobile card, the actual network standby, use the AT command to query the registration on the network, and record the average current of 10 minutes.	1.6

	Insert the unicom card, the actual network standby, use AT command to query and register the network, and record the 10-minute average current.	1.65
	Insert the telecom card, the actual network standby, use AT command to query and register the network, and record the average current of 10 minutes.	1.75
	GSM850 CH190 1) The tested module was powered on, and the data network was successfully registered; 2) Set the module to sleep state through AT instruction (USB is in suspended state); 3) Under the condition of no data transmission, the tested module maintained for 10 minutes and recorded the average current for 10 minutes.	1.6
GSM850	GSM850 CH128 1) The tested module was powered on, and the data network was successfully registered; 2) Set the module to sleep state through AT instruction (USB is in suspended state) 3) Under the condition of no data transmission, the tested module maintained for 10 minutes and recorded the average current for 10 minutes.	1.6
	Module is powered on With no data transfer, the USB is in a suspended state	
	GSM850 CH251 1) The tested module was powered on, and the data network was successfully registered; 2) Set the module to sleep state through AT instruction (USB is in suspended state); 3) Under the condition of no data transmission, the tested module maintained for 10 minutes and recorded the average current for 10 minutes.	1.5
GSM900	GSM900 CH62 1) The tested module was powered on, and the data network was successfully registered; 2) Set the module to sleep state through AT instruction (USB is in suspended state); 3) Under the condition of no data transmission, the tested module maintained for 10 minutes and recorded	1.4

the average current for 10 minutes.

GSM900 CH1

- 1) The tested module was powered on, and the data network was successfully registered;
 - 2) Set the module to sleep state through AT instruction (USB is in suspended state); 1.5
 - 3) Under the condition of no data transmission, the tested module maintained for 10 minutes and recorded the average current for 10 minutes.
-

GSM900 CH124

- 1) The tested module was powered on, and the data network was successfully registered;
 - 2) Set the module to sleep state through AT instruction (USB is in suspended state); 1.4
 - 3) Under the condition of no data transmission, the tested module maintained for 10 minutes and recorded the average current for 10 minutes.
-

DCS CH698

- 1) The tested module was powered on, and the data network was successfully registered;
 - 2) Set the module to sleep state through AT instruction (USB is in suspended state); 1.3
 - 3) Under the condition of no data transmission, the tested module maintained for 10 minutes and recorded the average current for 10 minutes.
-

DCS CH512

- 1) The tested module was powered on, and the data network was successfully registered;
 - 2) Set the module to sleep state through AT instruction (USB is in suspended state); 1.4
 - 3) Under the condition of no data transmission, the tested module maintained for 10 minutes and recorded the average current for 10 minutes.
-

DCS CH885

- 1) The tested module was powered on, 1.4
-

DCS

and the data network was successfully registered;
 2) Set the module to sleep state through AT instruction (USB is in suspended state);
 3) Under the condition of no data transmission, the tested module maintained for 10 minutes and recorded the average current for 10 minutes.

PCS CH661

1) The tested module was powered on, and the data network was successfully registered;
 2) Set the module to sleep state through AT instruction (USB is in suspended state);
 3) Under the condition of no data transmission, the tested module maintained for 10 minutes and recorded the average current for 10 minutes.

PCS CH512

1) The tested module was powered on, and the data network was successfully registered;
 2) Set the module to sleep state through AT instruction (USB is in suspended state);
 3) Under the condition of no data transmission, the tested module maintained for 10 minutes and recorded the average current for 10 minutes.

PCS

PCS CH810

1) The tested module was powered on, and the data network was successfully registered;
 2) Set the module to sleep state through AT instruction (USB is in suspended state);
 3) Under the condition of no data transmission, the tested module maintained for 10 minutes and recorded the average current for 10 minutes.

The module is powered on, and the DRX monitoring period of the idle state on

Band1 CH18300

1) The tested module was powered on, and the data network was successfully registered;
 2) Set the module to sleep state through AT instruction (USB is in suspended

FDD

the network is 1.28s With no data transfer, the USB is in a suspended state	state); 3) Under the condition of no data transmission, the tested module maintained for 10 minutes and recorded the average current for 10 minutes.	
	Band1 CH18050 1) The tested module was powered on, and the data network was successfully registered; 2) Set the module to sleep state through AT instruction (USB is in suspended state); 3) Under the condition of no data transmission, the tested module maintained for 10 minutes and recorded the average current for 10 minutes.	1.6
	Band1 CH18550 1) The tested module was powered on, and the data network was successfully registered; 2) Set the module to sleep state through AT instruction (USB is in suspended state); 3) Under the condition of no data transmission, the tested module maintained for 10 minutes and recorded the average current for 10 minutes.	1.6
	Band2 CH18650 1) The tested module was powered on, and the data network was successfully registered; 2) Set the module to sleep state through AT instruction (USB is in suspended state); 3) Under the condition of no data transmission, the tested module maintained for 10 minutes and recorded the average current for 10 minutes.	1.3
	Band2 CH18900 1) The tested module was powered on, and the data network was successfully registered; 2) Set the module to sleep state through AT instruction (USB is in suspended state); 3) Under the condition of no data transmission, the tested module maintained for 10 minutes and recorded	1.2

the average current for 10 minutes.

Band2 CH19150

- 1) The tested module was powered on, and the data network was successfully registered;
- 2) Set the module to sleep state through AT instruction (USB is in suspended state); 1.2
- 3) Under the condition of no data transmission, the tested module maintained for 10 minutes and recorded the average current for 10 minutes.

Band3 CH19575

- 1) The tested module was powered on, and the data network was successfully registered;
- 2) Set the module to sleep state through AT instruction (USB is in suspended state); 1.3
- 3) Under the condition of no data transmission, the tested module maintained for 10 minutes and recorded the average current for 10 minutes.

Band3 CH19250

- 1) The tested module was powered on, and the data network was successfully registered;
- 2) Set the module to sleep state through AT instruction (USB is in suspended state); 1.2
- 3) Under the condition of no data transmission, the tested module maintained for 10 minutes and recorded the average current for 10 minutes.

Band3 CH19900

- 1) The tested module was powered on, and the data network was successfully registered;
- 2) Set the module to sleep state through AT instruction (USB is in suspended state); 1.2
- 3) Under the condition of no data transmission, the tested module maintained for 10 minutes and recorded the average current for 10 minutes.

Band4 CH20000

- 1) The tested module was powered on, 1.3

and the data network was successfully registered;

2) Set the module to sleep state through AT instruction (USB is in suspended state);

3) Under the condition of no data transmission, the tested module maintained for 10 minutes and recorded the average current for 10 minutes.

Band4 CH20175

1) The tested module was powered on, and the data network was successfully registered;

2) Set the module to sleep state through AT instruction (USB is in suspended state); 1.2

3) Under the condition of no data transmission, the tested module maintained for 10 minutes and recorded the average current for 10 minutes.

Band4 CH20350

1) The tested module was powered on, and the data network was successfully registered;

2) Set the module to sleep state through AT instruction (USB is in suspended state); 1.2

3) Under the condition of no data transmission, the tested module maintained for 10 minutes and recorded the average current for 10 minutes.

Band5 CH20450

1) The tested module was powered on, and the data network was successfully registered;

2) Set the module to sleep state through AT instruction (USB is in suspended state); 1.4

3) Under the condition of no data transmission, the tested module maintained for 10 minutes and recorded the average current for 10 minutes.

Band5 CH20525

1) The tested module was powered on, and the data network was successfully registered; 1.4

2) Set the module to sleep state through AT instruction (USB is in suspended

state);

3) Under the condition of no data transmission, the tested module maintained for 10 minutes and recorded the average current for 10 minutes.

Band5 CH20600

1) The tested module was powered on, and the data network was successfully registered;

2) Set the module to sleep state through AT instruction (USB is in suspended state); 1.4

3) Under the condition of no data transmission, the tested module maintained for 10 minutes and recorded the average current for 10 minutes.

Band4 CH20175

1) The tested module was powered on, and the data network was successfully registered;

2) Set the module to sleep state through AT instruction (USB is in suspended state); 1.2

3) Under the condition of no data transmission, the tested module maintained for 10 minutes and recorded the average current for 10 minutes.

Band4 CH20350

1) The tested module was powered on, and the data network was successfully registered;

2) Set the module to sleep state through AT instruction (USB is in suspended state); 1.2

3) Under the condition of no data transmission, the tested module maintained for 10 minutes and recorded the average current for 10 minutes.

Band5 CH20450

1) The tested module was powered on, and the data network was successfully registered;

2) Set the module to sleep state through AT instruction (USB is in suspended state); 1.4

3) Under the condition of no data transmission, the tested module maintained for 10 minutes and recorded

the average current for 10 minutes.

Band4 CH20175

- 1) The tested module was powered on, and the data network was successfully registered;
 - 2) Set the module to sleep state through AT instruction (USB is in suspended state); 1.2
 - 3) Under the condition of no data transmission, the tested module maintained for 10 minutes and recorded the average current for 10 minutes.
-

Band4 CH20350

- 1) The tested module was powered on, and the data network was successfully registered;
 - 2) Set the module to sleep state through AT instruction (USB is in suspended state); 1.2
 - 3) Under the condition of no data transmission, the tested module maintained for 10 minutes and recorded the average current for 10 minutes.
-

Band5 CH20450

- 1) The tested module was powered on, and the data network was successfully registered;
 - 2) Set the module to sleep state through AT instruction (USB is in suspended state); 1.4
 - 3) Under the condition of no data transmission, the tested module maintained for 10 minutes and recorded the average current for 10 minutes.
-

Band4 CH20175

- 1) The tested module was powered on, and the data network was successfully registered;
 - 2) Set the module to sleep state through AT instruction (USB is in suspended state); 1.2
 - 3) Under the condition of no data transmission, the tested module maintained for 10 minutes and recorded the average current for 10 minutes.
-

Band4 CH20350

- 1) The tested module was powered on, 1.2
-

and the data network was successfully registered;

2) Set the module to sleep state through AT instruction (USB is in suspended state);

3) Under the condition of no data transmission, the tested module maintained for 10 minutes and recorded the average current for 10 minutes.

Band5 CH20450

1) The tested module was powered on, and the data network was successfully registered;

2) Set the module to sleep state through AT instruction (USB is in suspended state); 1.4

3) Under the condition of no data transmission, the tested module maintained for 10 minutes and recorded the average current for 10 minutes.

Band7 CH20800

1) The tested module was powered on, and the data network was successfully registered;

2) Set the module to sleep state through AT instruction (USB is in suspended state); 1.2

3) Under the condition of no data transmission, the tested module maintained for 10 minutes and recorded the average current for 10 minutes.

Band7 CH21100

1) The tested module was powered on, and the data network was successfully registered;

2) Set the module to sleep state through AT instruction (USB is in suspended state); 1.3

3) Under the condition of no data transmission, the tested module maintained for 10 minutes and recorded the average current for 10 minutes.

Band7 CH21400

1) The tested module was powered on, and the data network was successfully registered; 1.4

2) Set the module to sleep state through AT instruction (USB is in suspended

state);

3) Under the condition of no data transmission, the tested module maintained for 10 minutes and recorded the average current for 10 minutes.

Band8 CH21500

1) The tested module was powered on, and the data network was successfully registered;

2) Set the module to sleep state through AT instruction (USB is in suspended state); 1.3

3) Under the condition of no data transmission, the tested module maintained for 10 minutes and recorded the average current for 10 minutes.

Band8 CH21625

1) The tested module was powered on, and the data network was successfully registered;

2) Set the module to sleep state through AT instruction (USB is in suspended state); 1.2

3) Under the condition of no data transmission, the tested module maintained for 10 minutes and recorded the average current for 10 minutes.

Band8 CH21750

1) The tested module was powered on, and the data network was successfully registered;

2) Set the module to sleep state through AT instruction (USB is in suspended state); 1.4

3) Under the condition of no data transmission, the tested module maintained for 10 minutes and recorded the average current for 10 minutes.

Band20 CH24200

1) The tested module was powered on, and the data network was successfully registered;

2) Set the module to sleep state through AT instruction (USB is in suspended state); 1.4

3) Under the condition of no data transmission, the tested module maintained for 10 minutes and recorded

the average current for 10 minutes.

Band20 CH24300

- 1) The tested module was powered on, and the data network was successfully registered;
- 2) Set the module to sleep state through AT instruction (USB is in suspended state); 1.3
- 3) Under the condition of no data transmission, the tested module maintained for 10 minutes and recorded the average current for 10 minutes.

Band20 CH24400

- 1) The tested module was powered on, and the data network was successfully registered;
- 2) Set the module to sleep state through AT instruction (USB is in suspended state); 1.4
- 3) Under the condition of no data transmission, the tested module maintained for 10 minutes and recorded the average current for 10 minutes.

Band28 CH27260

- 1) The tested module was powered on, and the data network was successfully registered;
- 2) Set the module to sleep state through AT instruction (USB is in suspended state); 1.3
- 3) Under the condition of no data transmission, the tested module maintained for 10 minutes and recorded the average current for 10 minutes.

Band28 CH27435

- 1) The tested module was powered on, and the data network was successfully registered;
- 2) Set the module to sleep state through AT instruction (USB is in suspended state); 1.4
- 3) Under the condition of no data transmission, the tested module maintained for 10 minutes and recorded the average current for 10 minutes.

Band28 CH27610

- 1) The tested module was powered on, 1.4

		and the data network was successfully registered;	
		2) Set the module to sleep state through AT instruction (USB is in suspended state);	
		3) Under the condition of no data transmission, the tested module maintained for 10 minutes and recorded the average current for 10 minutes.	
		Band38 CH37800	
		1) The tested module was powered on, and the data network was successfully registered;	
		2) Set the module to sleep state through AT instruction (USB is in suspended state);	1.2
		3) Under the condition of no data transmission, the tested module maintained for 10 minutes and recorded the average current for 10 minutes.	
		Band38 CH38000	
		1) The tested module was powered on, and the data network was successfully registered;	
		2) Set the module to sleep state through AT instruction (USB is in suspended state);	1.3
		3) Under the condition of no data transmission, the tested module maintained for 10 minutes and recorded the average current for 10 minutes.	
Data transmission	TDD	1) Room temperature;	
		2) Dc power supply is used to supply the module, and the voltage is set at 3.8V;	
		Band38 CH38200	
		1) The tested module was powered on, and the data network was successfully registered;	
		2) Set the module to sleep state through AT instruction (USB is in suspended state);	1.3
		3) Under the condition of no data transmission, the tested module maintained for 10 minutes and recorded the average current for 10 minutes.	
		Band39 CH38300	
		1) The tested module was powered on, and the data network was successfully registered;	1.2
		2) Set the module to sleep state through AT instruction (USB is in suspended	

state);

3) Under the condition of no data transmission, the tested module maintained for 10 minutes and recorded the average current for 10 minutes.

Band39 CH38450

1) The tested module was powered on, and the data network was successfully registered;

2) Set the module to sleep state through AT instruction (USB is in suspended state); 1.3

3) Under the condition of no data transmission, the tested module maintained for 10 minutes and recorded the average current for 10 minutes.

Band39 CH38600

1) The tested module was powered on, and the data network was successfully registered;

2) Set the module to sleep state through AT instruction (USB is in suspended state); 1.3

3) Under the condition of no data transmission, the tested module maintained for 10 minutes and recorded the average current for 10 minutes.

Band40 CH38700

1) The tested module was powered on, and the data network was successfully registered;

2) Set the module to sleep state through AT instruction (USB is in suspended state); 1.2

3) Under the condition of no data transmission, the tested module maintained for 10 minutes and recorded the average current for 10 minutes.

Band40 CH39150

1) The tested module was powered on, and the data network was successfully registered;

2) Set the module to sleep state through AT instruction (USB is in suspended state); 1.3

3) Under the condition of no data transmission, the tested module maintained for 10 minutes and recorded

the average current for 10 minutes.

Band40 CH39600

- 1) The tested module was powered on, and the data network was successfully registered;
- 2) Set the module to sleep state through AT instruction (USB is in suspended state); 1.3
- 3) Under the condition of no data transmission, the tested module maintained for 10 minutes and recorded the average current for 10 minutes.

Band41 CH39990

- 1) The tested module was powered on, and the data network was successfully registered;
- 2) Set the module to sleep state through AT instruction (USB is in suspended state); 1.3
- 3) Under the condition of no data transmission, the tested module maintained for 10 minutes and recorded the average current for 10 minutes.

Band41 CH40640

- 1) The tested module was powered on, and the data network was successfully registered;
- 2) Set the module to sleep state through AT instruction (USB is in suspended state); 1.3
- 3) Under the condition of no data transmission, the tested module maintained for 10 minutes and recorded the average current for 10 minutes.

Band41 CH41190

- 1) The tested module was powered on, and the data network was successfully registered;
 - 2) Set the module to sleep state through AT instruction (USB is in suspended state); 1.3
 - 3) Under the condition of no data transmission, the tested module maintained for 10 minutes and recorded the average current for 10 minutes.
-

6.5 Environmental reliability requirements

Table 29 Environmental reliability requirements

Test Item	Test Condition
LTST	The temperature is -40°C, and the shutdown lasts for 24 hours
HTST	The temperature is +85°C, and the shutdown lasts for 24 hours
Thermal shock-TST	In the shutdown state, the temperature was -40°C and +85°C for 1h respectively. Temperature conversion time <3min, a total of 24 cycles
High temperature and humidity test	Temperature +85°C, humidity 95%RH, shutdown state for 48 hours
Low temperature running test	The temperature is -40°C, and the working condition lasts for 24 hours
High temperature running test	The temperature is +85°C, and the working condition lasts for 24 hours
Connection life test	Board to board connector interface plugs and unplugs for 50 times; RF antenna interface cable plug and unplug 30 times
ESD test	1. The module tests the power PAD and large area under the call state. ESD meets the following requirements: ①Contact discharge shall pass ±4KV, ±5KV test grades ②The air discharge shall pass ±8KV, ±10KV test grades 2、 Under the shutdown state, THE EVB SIM card holder is tested. ESD meets the following requirements: ①Contact discharge shall pass ±4KV test grade ②Air discharge shall pass ±8KV test grade 3、 Other interfaces of the module, ESD meets: ①Contact discharge shall pass ± 0.5kV test grade ②Air discharge shall pass ±1KV test grade

6.6 ESD character

Although SLM320 module design has been considered the ESD problem, and added the ESD protection, but consider SLM320 module during transportation and secondary development, it may also come across ESD problem. So, developers need to take into account of the final product ESD problem, besides the antistatic packaging processing, please refer to the reference design/recommended circuit of each hardware interface in this document.

Refer to the following table for the discharge range allowed by ESD for SLM320 module.

Table 30 ESD performance parameters (temperature: 25°C, humidity: 45%)

Test point	Contact discharge	Units	Test point
------------	-------------------	-------	------------

GND	±4	KV	GND
-----	----	----	-----

Antenna interface	±4	KV	Antenna interface
-------------------	----	----	-------------------

MeiG Confidential

7 Mechanical characteristics

This section describes the mechanical dimensions of the module, all in millimeters; All dimensions not marked with tolerance, tolerance is $\pm 0.05\text{mm}$.

7.1 Module Mechanical Dimensions

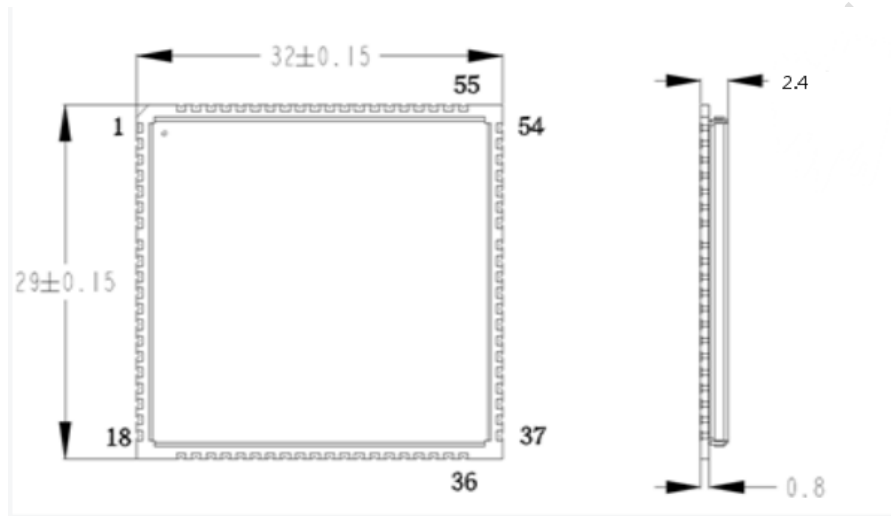
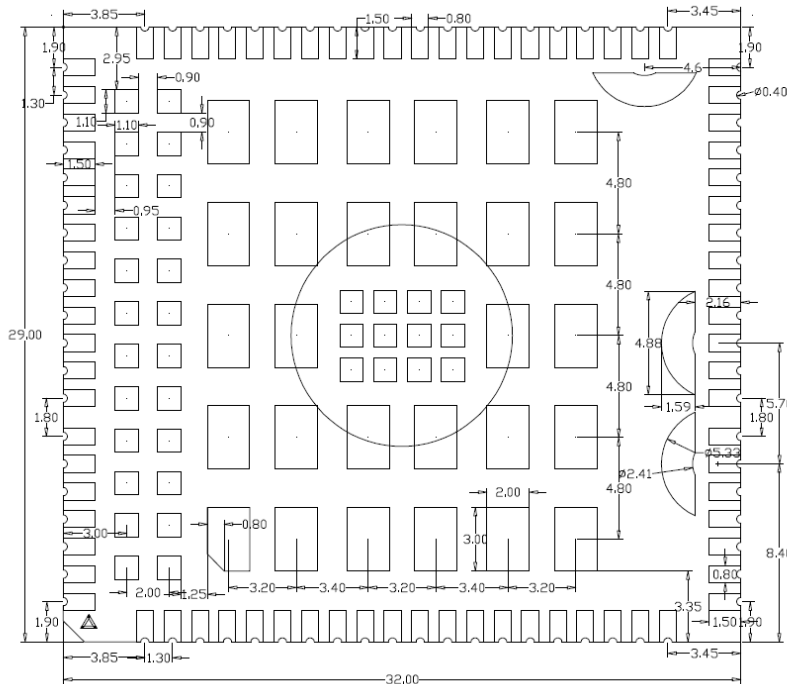
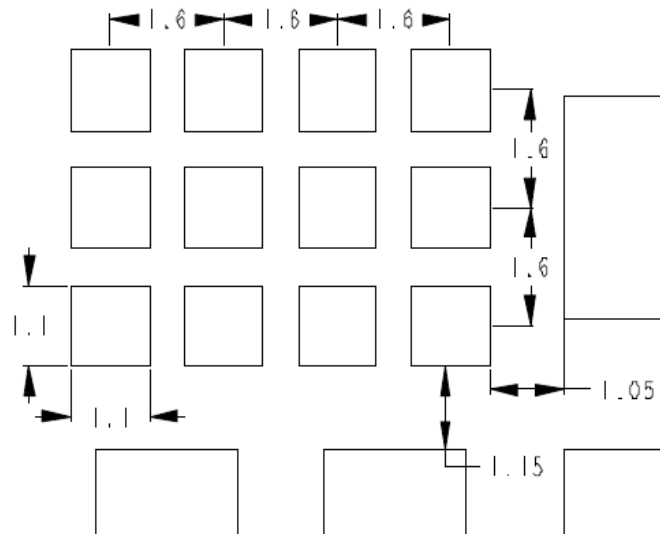

Figure 20 Module top and side dimensions (unit: mm)



a. Bottom view size



b. Bottom view size

Figure 21 bottom view dimension (unit: mm)

7.2 Recommended Footprint

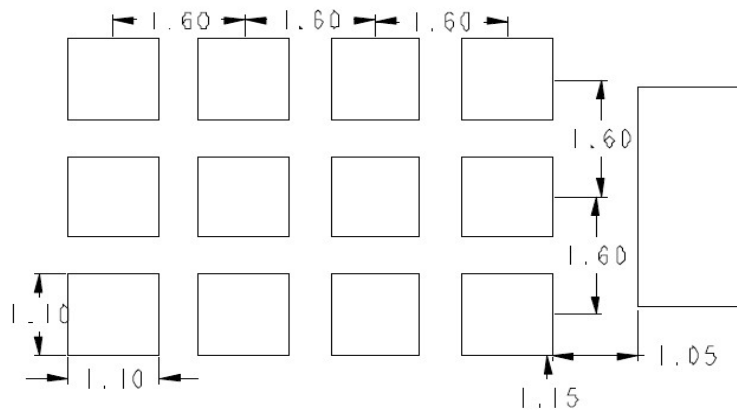
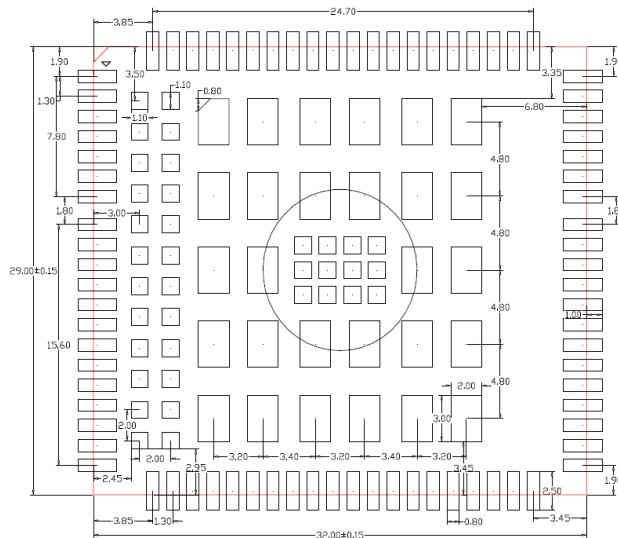

Figure 22 Recommended package (top view) (unit: mm)

7.3 Top View of Module



Figure 23 Top view of the module

7.4 Bottom View of Module

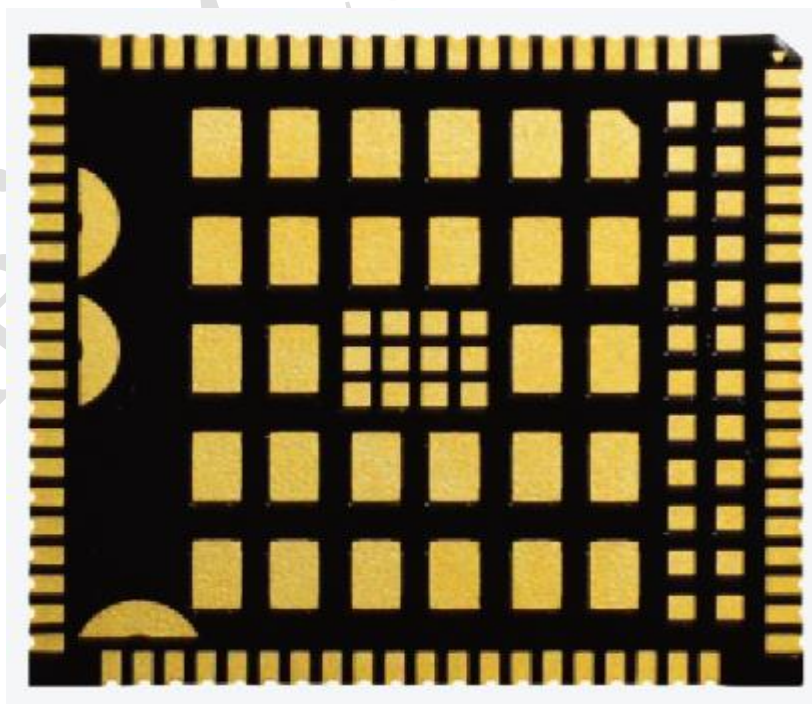

Figure 24 Bottom view of the module

8 Storage and production

8.1 Storage

SLM320 is shipped in vacuum sealed bags. The storage of modules shall be subject to the following conditions:

1. When the ambient temperature is lower than 40°C and the air humidity is less than 90%, the module can be stored in a vacuum sealed bag for 12 months;
2. After the vacuum seal bag is opened, the module can directly carry out reflow welding or other high-temperature processes if the following conditions are met:
 - The module stores air humidity less than 10%;
 - The environment temperature of module is lower than 30 °C, the air humidity is less than 60%, and the factory finishes the SMT within 72 hours.
3. If the module is under the following conditions, it needs to be baked before SMT;
 - When the ambient temperature is 23°C (5°C fluctuation is allowed), humidity level greater than 10%;
 - When the vacuum seal bag is opened, the ambient temperature of the module is lower than 30°C and the air humidity is less than 60%. However, the factory fails to complete the SMT within 168 hours;
 - When the vacuum seal bag is opened, the module stores air humidity greater than 10%.
4. If the module needs to be baked, bake at 125°C (fluctuation of 5°C above and below) for 8 hours.

Note:

The module packaging cannot withstand such high temperature, please remove the module packaging before the module baking.

8.2 Reflow Profile



Figure 25 Reflow temperature curve

8.3 Packaging

SLM320 adopts tray packaging, shown as below:

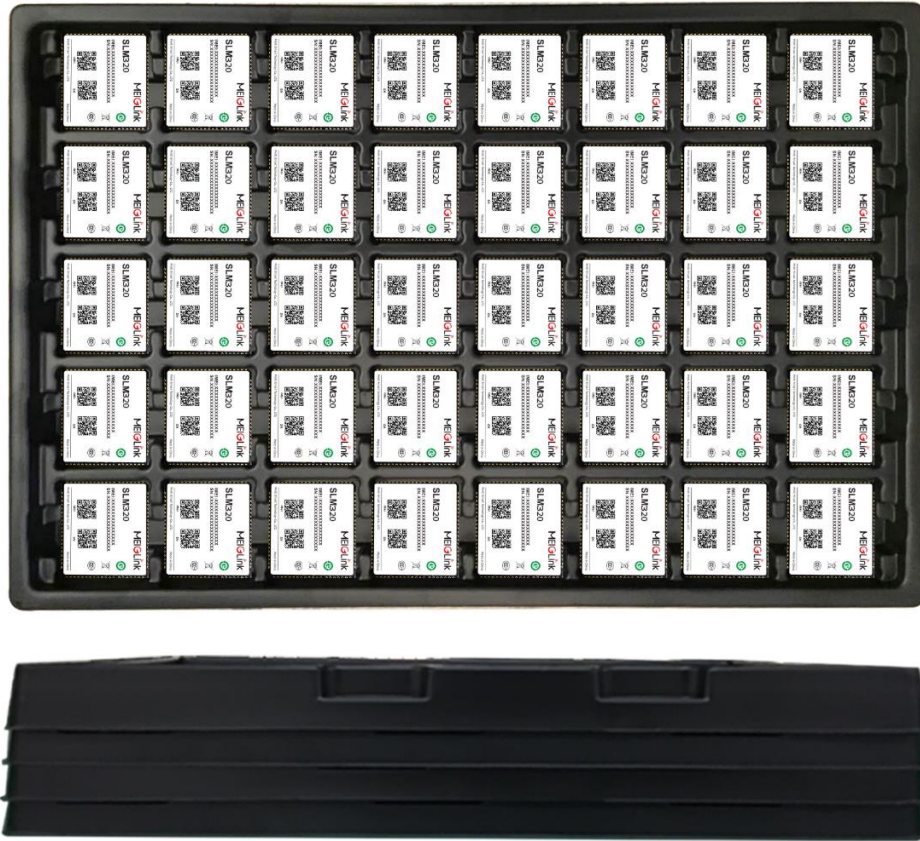

Figure 26 SLM320 in tray packaging

9 Appendix A refers to documentation and term abbreviations

9.1 Reference File

- SLM320 Module specifications;
- SLM320 AT Commands;
- SLM320 EVB user's manual
- SLM320 Reference design circuit;
- SLM320 Apply the business process manual.

9.2 Symbol Key

Table 31 Term abbreviations

Abbreviation	English description
AMR	Adaptive Multi-rate
BER	Bit Error Rate
BTS	Base Transceiver Station
PCI	Peripheral Component Interconnect
CS	Circuit Switched (CS) domain
CSD	Circuit Switched Data
DCE	Data communication equipment
DTE	Data terminal equipment
DTR	Data Terminal Ready
EDGE	Enhanced Data rates for GSM Evolution
EFR	Enhanced Full Rate
EGSM	Enhanced GSM
EMC	Electromagnetic Compatibility

ESD	Electrostatic Discharge
FR	Frame Relay
GMSK	Gaussian Minimum Shift Keying
GPIO	General Purpose Input Output
GPRS	General Packet Radio Service
GSM	Global Standard for Mobile Communications
HR	Half Rate
HSDPA	High Speed Downlink Packet Access
HSUPA	High Speed Uplink Packet Access
HSPA	HSPA High-Speed Packet Access
HSPA+	HSPA High-Speed Packet Access+
IEC	International Electro-technical Commission
IMEI	International Mobile Equipment Identity
MEID	Mobile Equipment Identifier
I/O	Input/Output
ISO	International Standards Organization
ITU	International Telecommunications Union
bps	bits per second
LED	Light Emitting Diode
M2M	Machine to machine
MO	Mobile Originated
MT	Mobile Terminated
NTC	Negative Temperature Coefficient
PC	Personal Computer
PCB	Printed Circuit Board

PCS	Personal Cellular System
PCM	Pulse Code Modulation
PCS	Personal Communication System
PDU	Packet Data Unit
PPP	Point-to-point protocol
PS	Packet Switched
QPSK	Quadrature Phase Shift Keying
SIM	Subscriber Identity Module
TCP/IP	Transmission Control Protocol/ Internet Protocol
UART	Universal asynchronous receiver-transmitter
USIM	Universal Subscriber Identity Module
UMTS	Universal Mobile Telecommunications System
USB	Universal Serial Bus
WCDMA	Wideband Code Division Multiple Access
TD-SCDMA	Time Division-Synchronous Code Division Multiple Access
TDD-LTE	Time Division Long Term Evolution
FDD-LTE	Frequency Division Duplexing Long Term Evolution
V _{max}	Maximum Voltage Value
V _{norm}	Normal Voltage Value
V _{min}	Minimum Voltage Value
V _{IHmax}	Maximum Input High Level Voltage Value
V _{IHmin}	Minimum Input High Level Voltage Value
V _{ILmax}	Maximum Input Low Level Voltage Value
V _{ILmin}	Minimum Input Low Level Voltage Value
V _{OHmax}	Maximum Output High Level Voltage Value

V_{OHmin}	Minimum Output High Level Voltage Value
V_{OLmax}	Maximum Output Low Level Voltage Value
V_{OLmin}	Minimum Output Low Level Voltage Value

MeiG Confidential

10 Appendix B GPRS Coding Scheme

Table 32 Description of different encoding schemes

Way	CS-1	CS-2	CS-3	CS-4
Code rate	1/2	2/3	3/4	1
USF	3	3	3	3
Pre-coded USF	3	6	6	12
Radio Block excl.USF and BCS	181	268	312	428
BCS	40	16	16	16
Tail	4	4	4	-
Coded Bits	456	588	676	456
Punctured Bits	0	132	220	-
Data rate Kb/s	9.05	13.4	15.6	21.4

FCC Caution.

§ 15.19 Labelling requirements.

This device complies with part 15 of the FCC Rules. Operation is subject to the condition that this device does not cause harmful interference.

§ 15.21 Information to user.

Any Changes or modifications not expressly approved by the party responsible for compliance could void the user's authority to operate the equipment.

§ 15.105 Information to the user.

Note: This equipment has been tested and found to comply with the limits for a Class B digital device, pursuant to part 15 of the FCC Rules. These limits are designed to provide reasonable protection against harmful interference in a residential installation. This equipment generates uses and can radiate radio frequency energy and, if not installed and used in accordance with the instructions, may cause harmful interference to radio communications. However, there is no guarantee that interference will not occur in a particular installation. If this equipment does cause harmful interference to radio or television reception, which can be determined by turning the equipment off and on, the user is encouraged to try to correct the interference by one or more of the following measures:

- Reorient or relocate the receiving antenna.
- Increase the separation between the equipment and receiver.
- Connect the equipment into an outlet on a circuit different from that to which the receiver is connected.
- Consult the dealer or an experienced radio/TV technician for help.

Body-worn Operation

This equipment complies with FCC radiation exposure limits set forth for an uncontrolled environment. This equipment should be installed and operated with minimum distance 20cm between the radiator & your body.

C.Appendix A

A1.Requirement of FCC KDB 996369 D03 for module certification:

1.1List of applicable FCC rules:

The module complies with FCC Part 2,22,24,27

1.2Summarize the specific operational use conditions:

SLM320 use the independent GPS chip , includes a fully integrated global navigation satellite system solution that supports GPS, GLONASS, BeiDou. It supports standard NMEA-0183 protocol.

1.3Limited module procedures:

The module does not have a standard antenna, which belong to Limited module Standard requires: Clear and specific instructions describing the conditions, limitations and procedures for third - parties to use and/or integrate the module into a host device (see Comprehensive integration instructions below).

Resolve: Supply example as follows:

Installation Notes:

- 1) SLM320-L Module Power supply range is DC 3.5V~4.2V, when you use SLM320-L Module design product, the power supply cannot exceed this range.
- 2) When connect SLM320-L Module to the host device, the host device must be power off.
- 3) Make sure the module pins correctly installed.
- 4) Make sure that the module does not allow users to replace or demolition.
- 5)All types of antennas that can be used with a transmitter: Max antenna gain not exceeding 3.5dBi in GSM850/1900
Max antenna gain not exceeding 5.1dBi in LTE band7
Max antenna gain not exceeding 3.9dBi in LTE band4

1.4Trace antenna designs: Not applicable.

1.5RF exposure considerations:

This equipment complies with FCC radiation exposure limits set forth for an uncontrolled environment. This equipment should be installed and operated withmini mum distance 20cm between the radiator & your body.

1.6Antennas:

The module does not have a standard antenna.

1.7Label and compliance information

This device complies with part 15 of the FCC Rules. Operation is subject to the condition that this device does not cause harmful interference.Any Changes or modifications not expressly approved by the party responsible for compliance could void the user's authority to operate the equipment.

Note: This equipment has been tested and found to comply with the limits for a Class B digital device, pursuant to part 15 of the FCC Rules. These limits are designed to provide reasonable protection against harmful interference in a residential installation. This equipment generates uses and can radiate radio frequency energy and, if not installed and used in accordance with the instructions, may cause harmful interference to radio communications. However, there is no guarantee that interference will not occur in a particular installation. If this equipment does cause harmful interference to radio or television reception, which can be determined by turning the equipment off and on, the user is encouraged to try to correct the interference by one or more of the following measures:

- Reorient or relocate the receiving antenna.
- Increase the separation between the equipment and receiver.
- Connect the equipment into an outlet on a circuit different from that to which the receiver is connected.
- Consult the dealer or an experienced radio/TV technician for help.

Body-worn Operation

This equipment complies with FCC radiation exposure limits set forth for an uncontrolled environment. This equipment should be installed and operated with minimum distance 20cm between the radiator & your body The host product Labeling Requirements:
NOTICE: The host product must make sure that FCC labeling requirements are met. This includes clearly visible exterior label on the outside of the final product housing that displays the contents shown in below:

Contains FCC ID:2APJ4-SLM320-L

1.8 Information on test modes and additional testing requirements:

When setting up the configuration, if the pairing and call box options for testing do not work, the tester needs to coordinate with the module manufacturer to access the test mode software.

1.9 Additional testing, Part 15 Subpart B disclaimer:

The modular transmitter is only FCC authorized for the specific rule parts (FCC Part 2,22,24,27) list on the grant, and that the host product manufacturer is responsible for compliance to any other FCC rules that apply to the host not covered by the modular transmitter grant of certification.

1.10 Information on test modes and additional testing requirements:

When testing, testers need to refer to the user manual, and the sample power supply needs to use a special adapter power supply.