

MeiG_SLM156_EVB UGD

Controlled Version Number: V1.0

Release Date: 2019/05/29



Important Notice

Copyright Notice

All rights reserved. MeiG Smart Technology Co., Ltd

This manual and all its contents are owned by MeiG Smart Technology Co., Ltd and protected by Chinese laws and relevant copyright laws in applicable international conventions. Without the written authorization of MeiG Smart Technology Co., Ltd, no one may copy, disseminate, distribute, modify or use part or all of this manual in any form, and the offenders will be held responsible according to law.

Statement of No Guarantee

MeiG Smart Technology Co., Ltd makes no representations or guarantees, either express or implied, for any contents in this document, and assumes no responsibility for the merchantability and fitness for a particular purpose or any indirect, extraordinary or consequential losses.

Confidentiality Claim

The information contained in this document (including any annexes) is confidential. The recipient understands that the document obtained by him is confidential and shall not be used for any purpose other than the stated purpose, and he shall not disclose this document to any third party.

Disclaimer

The company assumes no responsibility for property damage or personal injury caused by customers' improper operation. Customers are requested to develop corresponding products according to the technical specifications and reference designs in the manual. Before the disclaimer, the company has the right to change the contents of this manual according to the needs of technological development, and the version is subject to change without further notice.

Revision History

| Version | Date | Reason for Revision |
|---------|------------|---------------------------------|
| V1.0 | 2019-05-29 | Establish for the first version |

Contents

| | |
|--|-----------|
| Important Notice | 1 |
| Revision History | 2 |
| Contents | 3 |
| Table Index | 4 |
| Figure Index | 5 |
| 1 Introduction | 6 |
| 1.1 Safety Instructions..... | 7 |
| 1.2 Purpose of the Document..... | 8 |
| 1.3 List of Contents..... | 8 |
| 2 Product Overview | 9 |
| 2.1 SLM156 Module Basic Description..... | 9 |
| 3 Development board interface | 10 |
| 3.1 Basic interface..... | 10 |
| 3.2 SIM card interface..... | 10 |
| 3.3 Power supply USB interface..... | 12 |
| 3.4 Main USB interface..... | 13 |
| 3.5 Main serial port..... | 14 |
| 3.6 DEBUG serial port..... | 16 |
| 3.7 Power key..... | 18 |
| 3.8 Reserved key..... | 19 |
| 3.9 Jumper cap..... | 20 |
| 3.10 Indicator LED..... | 21 |

Table Index

| | | |
|---------|---|----|
| Table 1 | Interface definition of SIM card holder | 11 |
| Table 2 | Interface definition of power supply USB socket | 12 |
| Table 3 | Main USB interface definition..... | 14 |
| Table 4 | Main serial port DB9 interface definition | 15 |
| Table 5 | DEBUG serial port DB9 interface definition | 17 |
| Table 6 | Function description of jumper cap | 20 |
| Table 7 | LED indicator function description | 21 |

Figure Index







| | | |
|-----------|--|----|
| Figure 1 | Development board interface diagram | 9 |
| Figure 2 | SIM card connection diagram..... | 10 |
| Figure 3 | SIM card seat location map | 11 |
| Figure 4 | USB connection diagram of power supply | 12 |
| Figure 5 | Power supply USB location diagram | 13 |
| Figure 6 | Main USB connection diagram..... | 13 |
| Figure 7 | Main USB location map | 14 |
| Figure 8 | Main serial port connection diagram | 15 |
| Figure 9 | Main serial port location map | 16 |
| Figure 10 | DEBUG serial port connection diagram | 16 |
| Figure 11 | DEBUG serial port location diagram | 17 |
| Figure 12 | Power-on key location diagram..... | 18 |
| Figure 13 | Reservation key location map | 19 |
| Figure 14 | Location diagram of jumper cap..... | 20 |
| Figure 15 | Location diagram of indicator LED | 21 |

1 Introduction

This document defines the SLM156 development board and describes the interfaces and functions of the development board. It can help customers quickly understand the interface usage of SLM156 module development board.

1.1 Safety Instructions

By complying with the following safety principles, you can ensure personal safety and protect the products and working environment from potential damage:

| | |
|---|--|
|  | Driving safety first! When you drive, do not use handheld mobile terminal device unless it has a hands-free function. Please stop the car before calling! |
|  | Please turn off the mobile terminal device before boarding. The wireless function of mobile terminal shall not be turned on in the aircraft to prevent interference with the aircraft communication system. Ignoring this reminder may affect flying safety or even violate the law. |
|  | In hospitals or health care facilities, pay attention to whether there are restrictions on the use of mobile terminal device. RF interference will cause medical equipment to be abnormal, so mobile terminal device may need to be turned off. |
|  | Mobile terminal device cannot always be effectively connected, for example, if the mobile device has no expense or the SIM is invalid. When you encounter the above situations in an emergency, please make an emergency call, meanwhile, ensure that your device is turned on and in an area with sufficient signal strength. |
|  | Your mobile terminal device will receive and transmit radio frequency signals when it is turned on. There will be radio frequency interference when it is close to TV, radio, computer or other electronic equipment. |
|  | Please keep mobile device away from inflammable gases. Please turn off the mobile terminal device when you are near a fueling station, oil depot, chemical plant or explosion site. There will be potential safety hazards when operating electronic equipment in any place with potential explosion hazard. |

1.2 Purpose of the Document

This paper elaborates the interface and usage of SLM156 module development board, and guides the users to use and develop SLM156 module on the development board.

1.3 List of Contents

The document includes:

- Chapter 1 introduces safety information, purpose of the document and revising records;
- Chapter 2 describes basic description of the SLM156 wireless module;
- Chapter 3 describes functions and usage of each hardware interface of SLM156 development board are introduced;

2 Product Overview

2.1 SLM156 Module Basic Description

SLM156 is a multi - mode IOT wireless communication module, which supports half-duplex LTE and does not support diversity receiving function. SLM156 can provide data connection under LTE-FDD, TD-LTE, GPRS and EGPRS networks, and it also supports GNSS and voice function. Through radio communication protocol, SLM156 module can establish communication with network operator's infrastructure.

SLM156 adopts advanced highly integrated design scheme, which integrates RF and baseband into an LCC patch package to complete baseband signal processing, wireless transmission and reception and other functions. Single-sided layout is adopted, and the structural size of the module is: 21.0mm *20.0mm* 2.3mm.It can meet almost all the application needs of M2M, such as intelligent measurement, Shared bicycle, intelligent parking, smart city, security, asset tracking, smart home appliances, agriculture and environmental monitoring.

This development board has connected all the interfaces of SLM156 module, and is equipped with PCB antenna. Users can directly use the module without any other auxiliary debugging work.

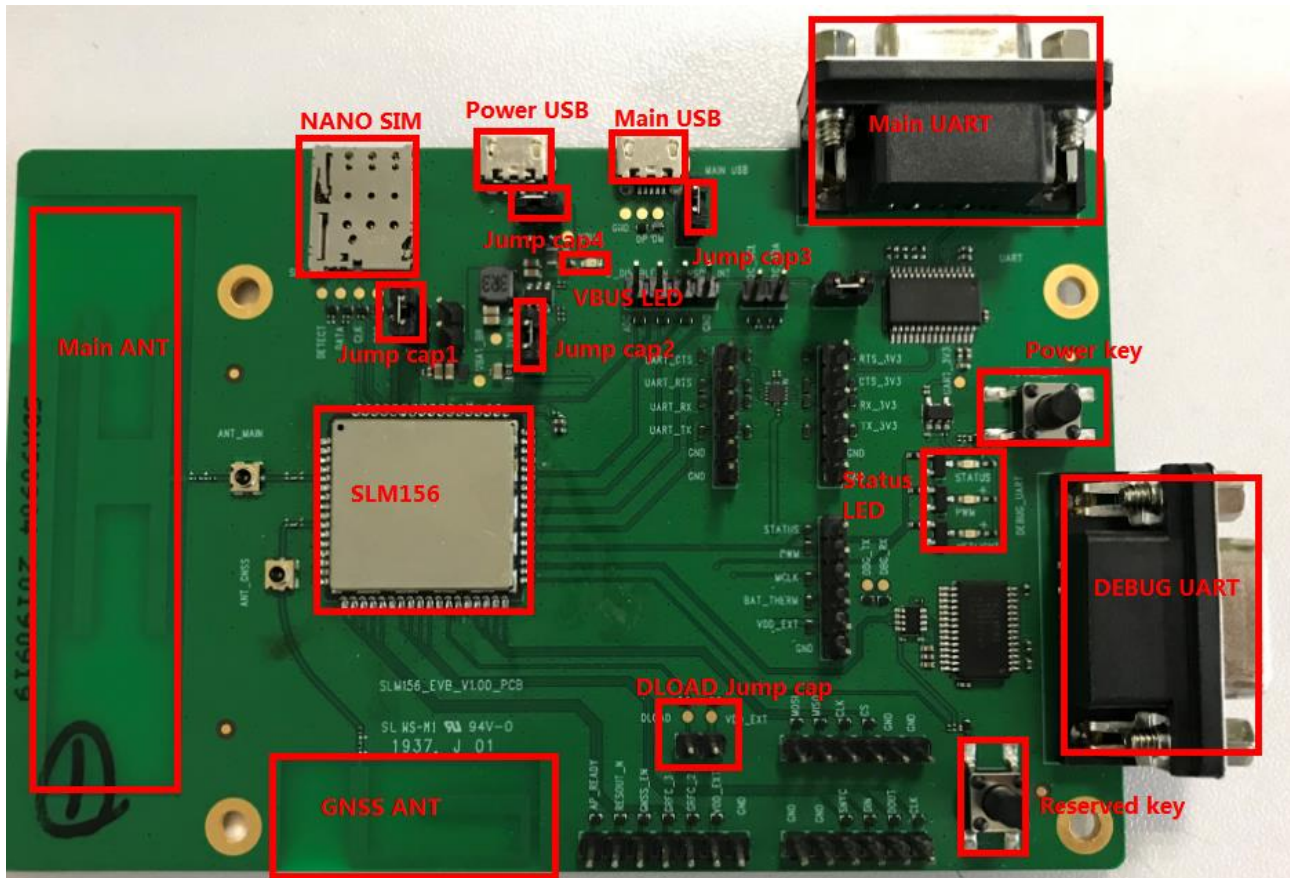

Figure 1 Development board interface diagram

3 Development board interface

3.1 Basic interface

The SLM156 development board provides the following interfaces:

1. NANO SIM card interface, NANO SIM card can be used;
2. Power USB interface. When the main USB power supply is insufficient, it can be connected to the adapter for power supply;
3. Main USB interface, USB communication and power supply;
4. MAIN UART DB9 interface, the DB9 interface extracted from the main serial port of the module can be directly used to communicate with the computer;
5. DEBUG UART DB9 interface, module DEBUG serial port from the DB9 interface, you can directly use the DB9 interface and computer communication;
6. Power key, press the power button to start the machine;
7. Reserved key, the reserved keys are for user debugging;
8. Jump cap 1: SIM card power supply jump cap, need to be connected to use SIM card;
9. Jump cap 2: module VBAT(3.8V) power supply jumper cap, which needs to be connected to the module for power supply;
10. Jump cap 3: the main USB 5V power supply jump cap shall be connected to the main USB;
11. Jump cap 4: the power supply USB jump cap shall be connected to the power supply USB;
12. Dload jump cap: when the module needs to force loading, it needs to attach this jumper.

3.2 SIM card interface

The development board provides a 6-pin-push-push SIM card holder that supports 1.8V SIM card. The following figure 2 shows a simple connection between the SLM156 module and the SIM card holder.

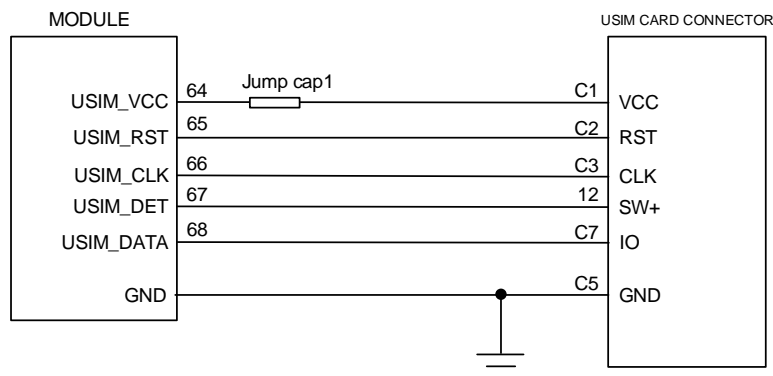

Figure 2 SIM card connection diagram

The following figure 3 shows the SIM card interface of the single board. The software does not support hot-plugging by default. If the SIM card is used, please insert the SIM card before power-on.

Table 1 Interface definition of SIM card holder

| Pin name | Pin number | I/O | Description |
|----------|------------|-----|-------------------------|
| SW | 12 | DI | SIM card plug detection |
| VCC | C1 | PO | USIM card power supply |
| IO | C7 | IO | USIM card data signal |
| CLK | C3 | DO | USIM card clock signal |
| RST | C2 | DO | USIM card reset signal |
| GND | C5 | - | Connect GND |
| VPP | C6 | | NO Connect |

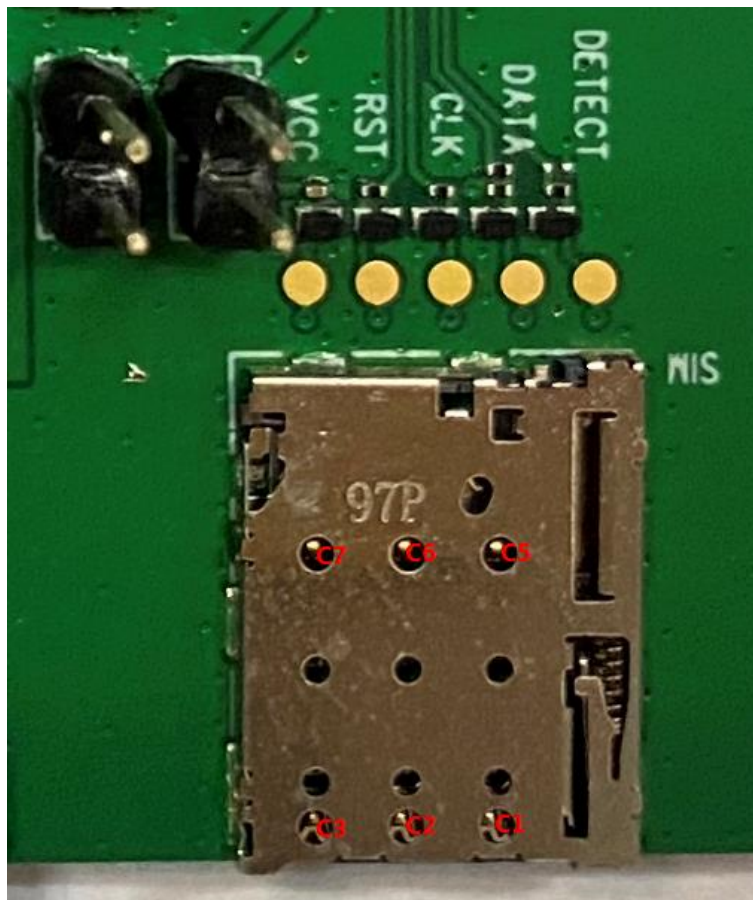

Figure 3 SIM card seat location map

3.3 Power supply USB interface

The development board provides a Micro USB interface for power supply. When the power supply of the main USB interface is insufficient, the power supply capability can be increased by using the POWER supply USB interface. Figure 4 shows the connection between the power SUPPLY USB interface and modules on the EVB board, and Figure 5 shows the position of the power supply USB interface on the EVB board. The use of power supply USB interface requires jumper cap 4 to be plugged in and USB cable to be plugged in.

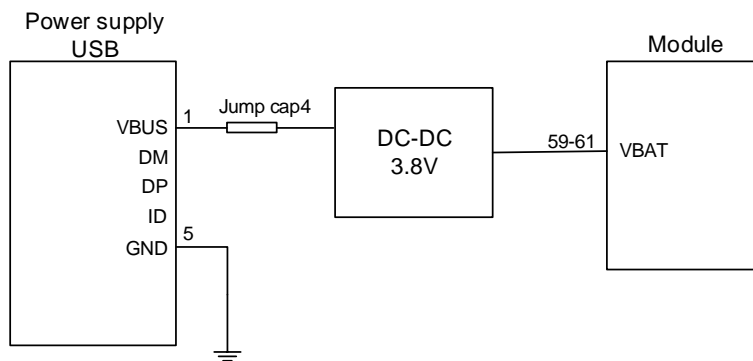

Figure 4 USB connection diagram of power supply

Table 2 Interface definition of power supply USB socket

| Pin name | Pin number | I/O | Description |
|----------|------------|-----|-------------|
| VBUS | 1 | PI | Power input |
| DM | 2 | | NO Connect |
| DP | 3 | | NO Connect |
| ID | 4 | | NO Connect |
| GND | 5 | - | Connect GND |

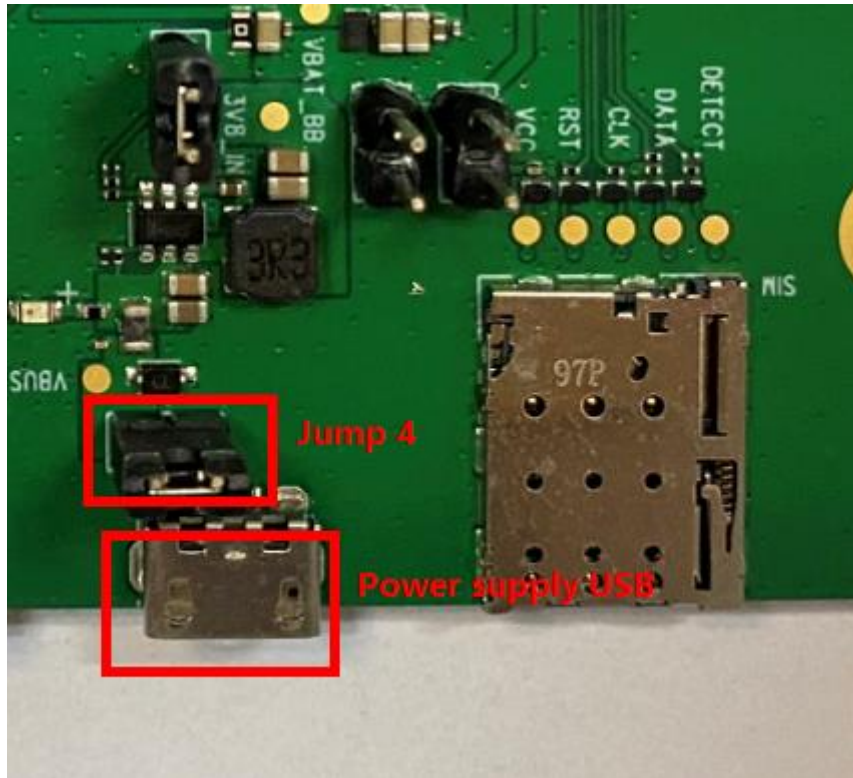

Figure 5 Power supply USB location diagram

3.4 Main USB interface

The development board provides a master USB interface for data transfer and power supply. The master USB interface conforms to the USB2.0 standard and supports high speed (480Mbps) and full speed (12Mbps) modes. USB interfaces are used for AT command interaction, data transfer, software debugging and version upgrading, etc. DP/DM go line need difference go line, need 90 Ω differential impedance. The power supply for the main USB interface needs to be plugged in with jumper cap 3 and USB cable plugged in.

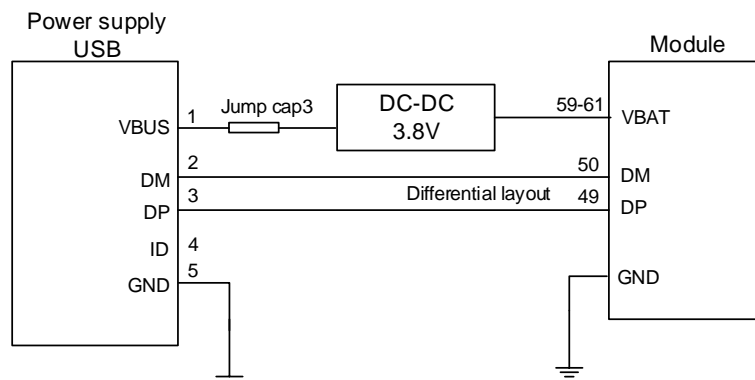

Figure 6 Main USB connection diagram

Table 3 Main USB interface definition

| Pin name | Pin number | I/O | Description |
|----------|------------|-----|--------------------------------|
| VBUS | 1 | PI | Power input |
| DM | 2 | IO | USB differential data signal - |
| DP | 3 | IO | USB differential data signal + |
| ID | 4 | | NO Connect |
| GND | 5 | - | Connect GND |

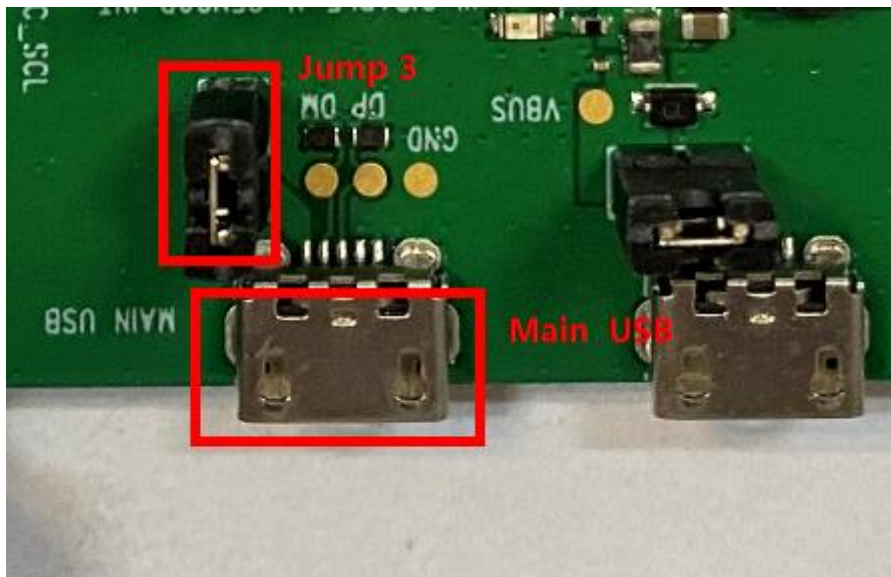

Figure 7 Main USB location map

3.5 Main serial port

Development board provides a main serial port for data transfer and AT command transfer. The main serial port supports 9600, 19200, 38400, 57600, 115200, 230400, 460800, 921600bps baud rate. The default baud rate is 115200bps.

Figure 8 shows the connection block diagram of the MAIN serial port DB9 interface and modules on the EVB board.

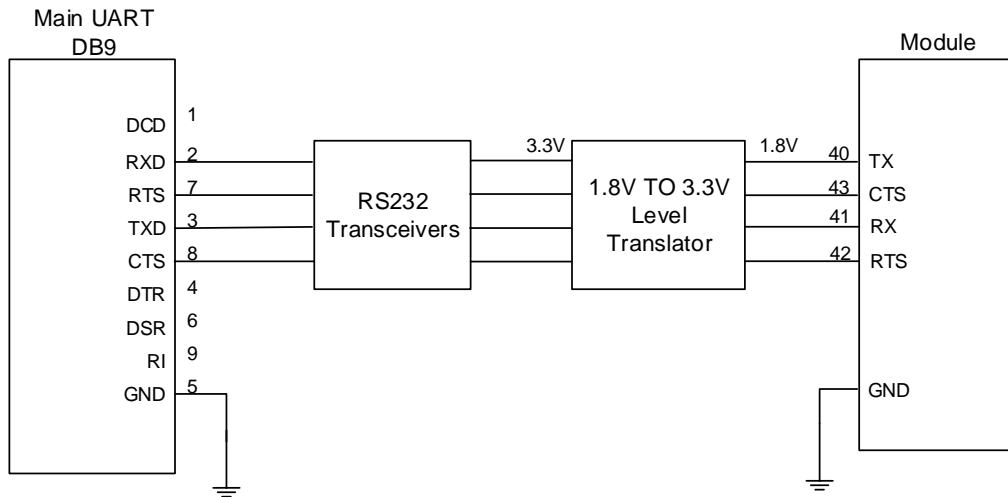

Figure 8 Main serial port connection diagram

Table 4 Main serial port DB9 interface definition

| Pin name | Pin number | I/O | Description |
|----------|------------|-----|-----------------|
| DCD | 1 | - | NO Connect |
| RXD | 2 | DI | Receive data |
| RTS | 7 | DI | Request to send |
| TXD | 3 | DO | Transmit data |
| CTS | 8 | DO | Clear to send |
| DTR | 4 | - | NO Connect |
| DSR | 6 | - | NO Connect |
| RI | 9 | - | NO Connect |
| GND | 5 | - | Connect GND |

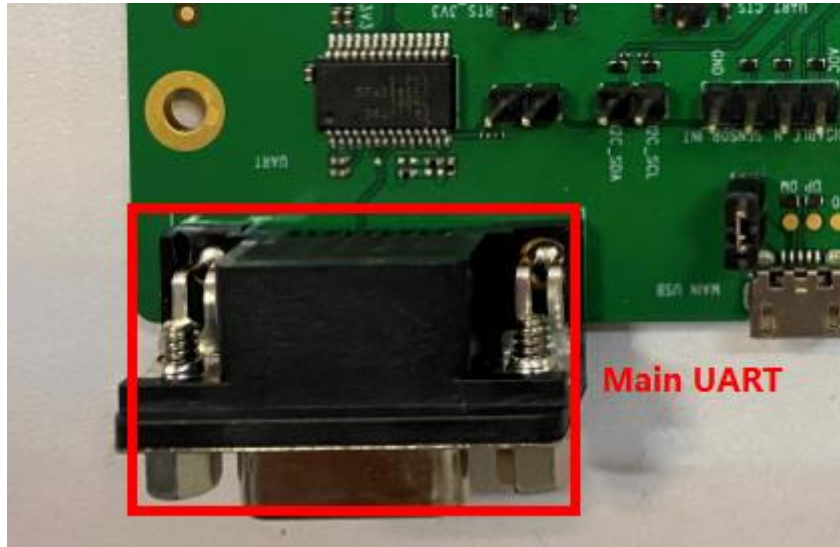

Figure 9 Main serial port location map

3.6 DEBUG serial port

The development board provides a DEBUG serial port for module debugging and log output, supporting a baud rate of 115200bps.

Figure 8 shows the connection block diagram of the DEBUG serial port DB9 interface and modules on the EVB board.

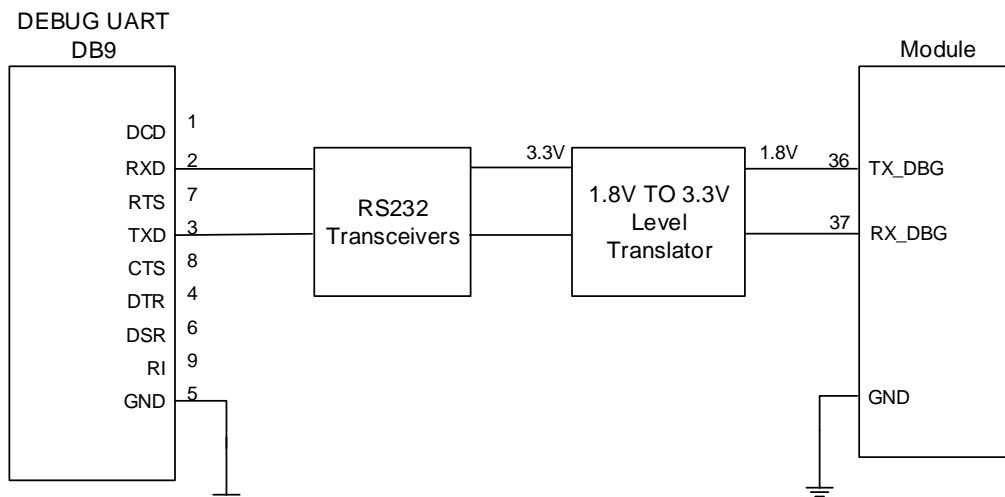

Figure 10 DEBUG serial port connection diagram

Table 5 DEBUG serial port DB9 interface definition

| Pin name | Pin number | I/O | Description |
|----------|------------|-----|---------------|
| DCD | 1 | - | NO Connect |
| RXD | 2 | DI | Receive data |
| RTS | 7 | | NO Connect |
| TXD | 3 | DO | Transmit data |
| CTS | 8 | | NO Connect |
| DTR | 4 | - | NO Connect |
| DSR | 6 | - | NO Connect |
| RI | 9 | - | NO Connect |
| GND | 5 | - | Connect GND |

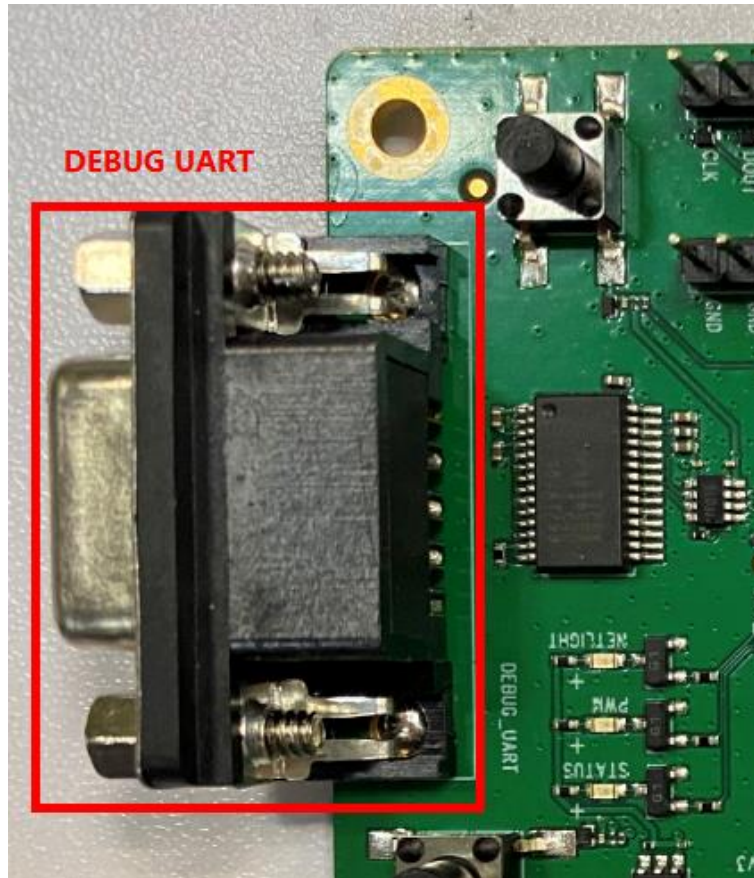

Figure 11 DEBUG serial port location diagram

3.7 Power key

The development board provides a button to switch the machine on and off. After the EVB board is powered on, press the button to turn the module on. After starting up, press the button and hold for at least 3s, and the module executes the shutdown process.



Figure 12 Power-on key location diagram

3.8 Reserved key

The development board provides a reserved signal button, which is connected to GPIO of SLM156 module and allows the software to configure the function of this button as required.

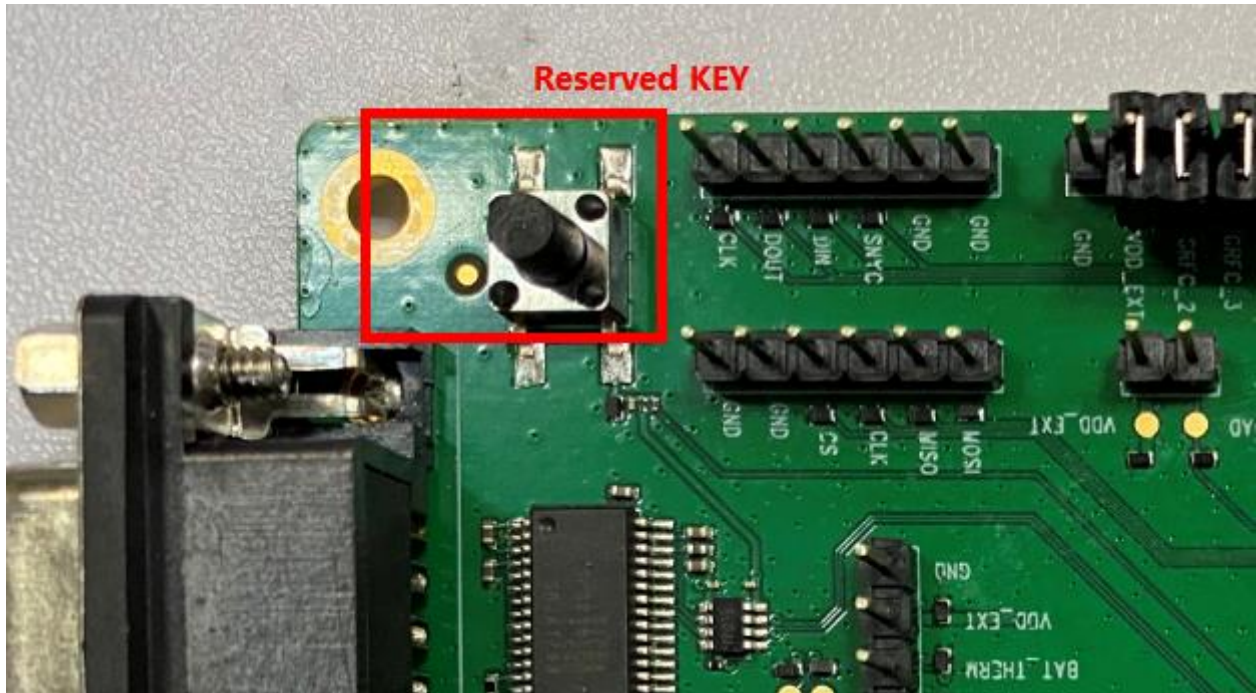

Figure 13 Reservation key location map

3.9 Jumper cap

The development board provides a number of jumper caps that can be attached as needed when used. The functions of jumper cap are shown in the following table:

Table 6 Function description of jumper cap

| Jump cap name | Description |
|----------------|---|
| Jump cap1 | SIM card power supply jumper cap, need to be connected to use SIM card |
| Jump cap2 | Module VBAT(3.8V) power supply jumper cap, which needs to be connected to the module for power supply |
| Jump cap3 | The main USB 5V power supply jump cap shall be connected to the main USB |
| Jump cap4 | The power supply USB interface jump cap shall be connected to the power supply USB |
| DLOAD Jump cap | When the module needs to force loading, it needs to attach this jumper |

The following figure shows the location of the jumper cap on the EVB board:

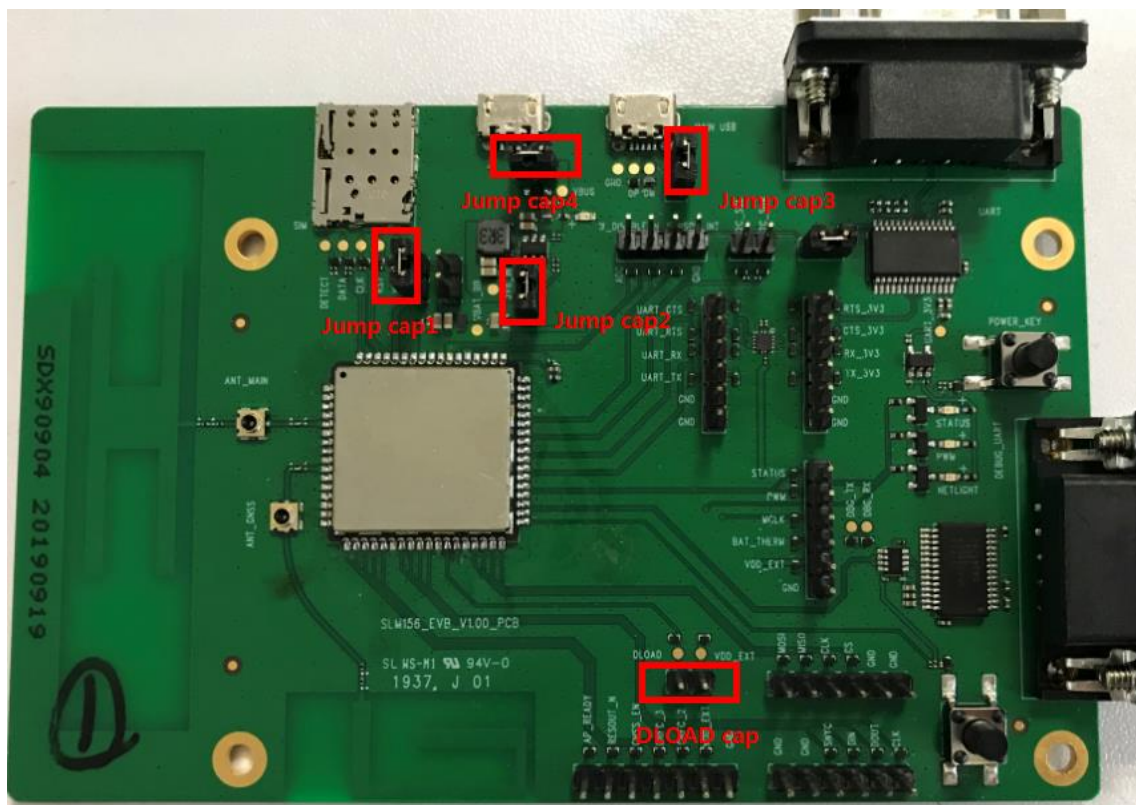

Figure 14 Location diagram of jumper cap

3.10 Indicator LED

The development board provides some indicators. The indicator LED marking function is shown in the following table:

Table 7 LED indicator function description

| LED name | Description |
|--------------|--|
| VBUS LED | When the VBUS power supply is normal, the VBUS LED is always on, and the single board is normally powered on |
| STATUS LED | When the module is normally started, the STATUS LED will always be on |
| NETLIGHT LED | Indicator LED indicating the network status of modules, often off without network service; When there is a network, it flashes according to the state of the network |

The following figure shows the location of the indicator LED on the EVB board:

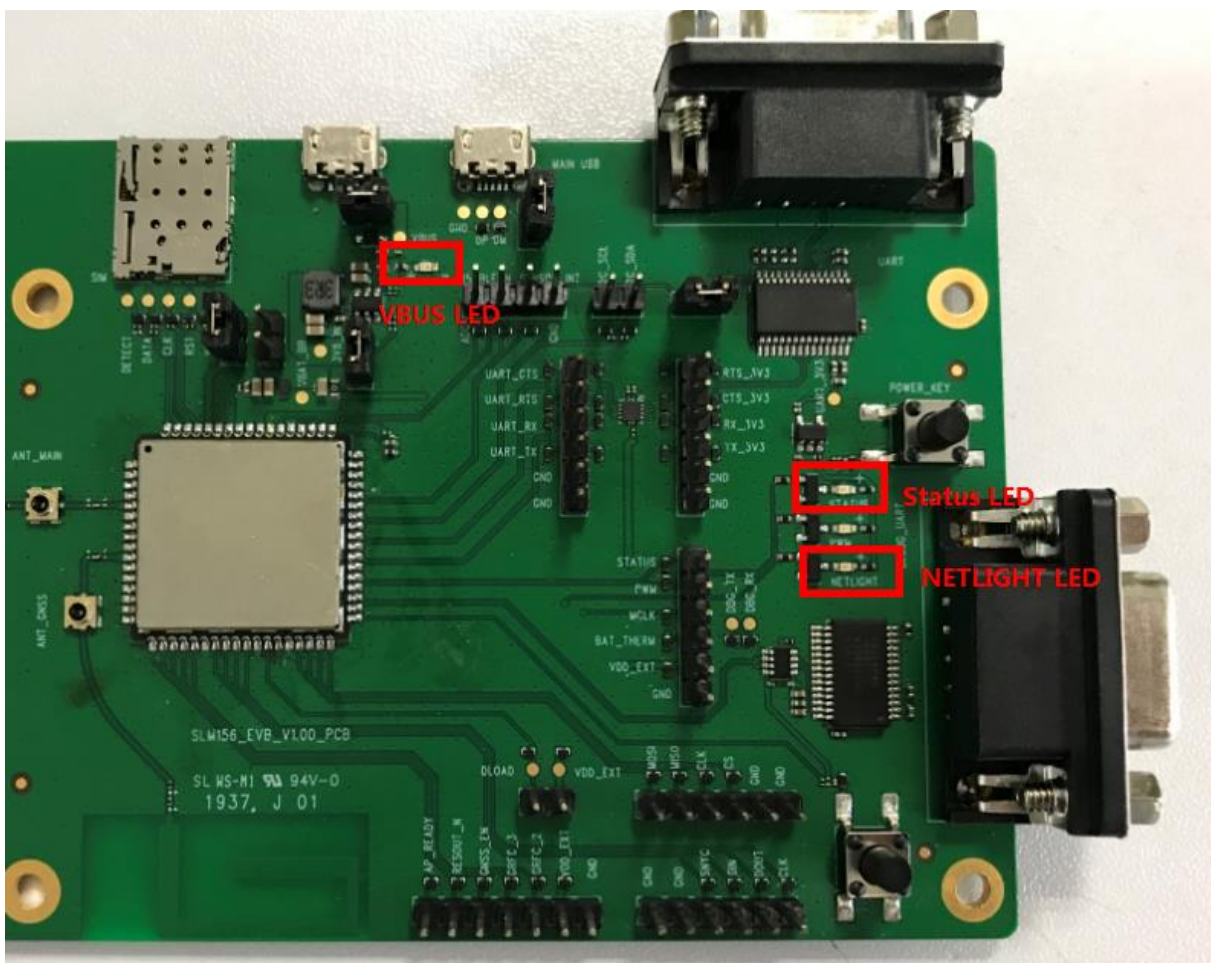

Figure 15 Location diagram of indicator LED

OEM/Integrators Installation Manual

Important Notice to OEM integrators 1. This module is limited to OEM installation ONLY. 2. This module is limited to installation in mobile or fixed applications, according to Part 2.1091(b). 3. The separate approval is required for all other operating configurations, including portable configurations with respect to Part 2.1093 and different antenna configurations 4. For FCC Part 15.31 (h) and (k): The host manufacturer is responsible for additional testing to verify compliance as a composite system. When testing the host device for compliance with Part 15 Subpart B, the host manufacturer is required to show compliance with Part 15 Subpart B while the transmitter module(s) are installed and operating. The modules should be transmitting and the evaluation should confirm that the module's intentional emissions are compliant (i.e. fundamental and out of band emissions). The host manufacturer must verify that there are no additional unintentional emissions other than what is permitted in Part 15 Subpart B or emissions are complaint with the transmitter(s) rule(s). The Grantee will provide guidance to the host manufacturer for Part 15 B requirements if needed.

Important Note

notice that any deviation(s) from the defined parameters of the antenna trace, as described by the instructions, require that the host product manufacturer must notify to Quectel that they wish to change the antenna trace design. In this case, a Class II permissive change application is required to be filed by the USI, or the host manufacturer can take responsibility through the change in FCC ID (new application) procedure followed by a Class II permissive change application

End Product Labeling

When the module is installed in the host device, the FCC ID label must be visible through a window on the final device or it must be visible when an access panel, door or cover is easily re-moved. If not, a second label must be placed on the outside of the final device that contains the following text: "Contains FCC ID: [2APJ4-SLM156](#)". The FCC ID can be used only when all FCC compliance requirements are met.

Antenna

- (1) The antenna must be installed such that 20 cm is maintained between the antenna and users,
- (2) The transmitter module may not be co-located with any other transmitter or antenna.

In the event that these conditions cannot be met (for example certain laptop configurations or co-location with another transmitter), then the FCC authorization is no longer considered valid and the FCC ID cannot be used on the final product. In these circumstances, the OEM integrator will be responsible for re-evaluating the end product (including the transmitter) and obtaining a separate FCC authorization.

To comply with FCC regulations limiting both maximum RF output power and human exposure to RF radiation, maximum antenna gain (including cable loss) must not exceed

| Test Mode | Antenna Gain (dBi) | Test Mode | Antenna Gain (dBi) |
|---------------|--------------------|----------------|--------------------|
| GSM 850 | 0.44 | NB-IoT Band 2 | 0.78 |
| PCS 1900 | 0.78 | NB-IoT Band 4 | -0.10 |
| Cat M Band 2 | 0.78 | NB-IoT Band 5 | 0.44 |
| Cat M Band 4 | -0.10 | NB-IoT Band 12 | 1.72 |
| Cat M Band 5 | 0.44 | NB-IoT Band 13 | 1.59 |
| Cat M Band 12 | 1.72 | NB-IoT Band 25 | 0.71 |
| Cat M Band 13 | 1.59 | NB-IoT Band 26 | 0.49 |
| Cat M Band 14 | 0.66 | NB-IoT Band 66 | -0.10 |
| Cat M Band 25 | 0.71 | NB-IoT Band 71 | -2.38 |
| Cat M Band 26 | 0.49 | -- | -- |
| Cat M Band 66 | -0.10 | -- | -- |

Manual Information to the End User

The OEM integrator has to be aware not to provide information to the end user regarding how to install or remove this RF module in the user’s manual of the end product which integrates this module. The end user manual shall include all required regulatory information/warning as show in this manual.

Federal Communication Commission Interference Statement

This device complies with Part 15 of the FCC Rules. Operation is subject to the following two conditions: (1) This device may not cause harmful interference, and (2) this device must accept any interference received, including interference that may cause undesired operation.

This equipment has been tested and found to comply with the limits for a Class B digital device, pursuant to Part 15 of the FCC Rules. These limits are designed to provide reasonable protection against harmful interference in a residential installation. This equipment generates, uses and can radiate radio frequency energy and, if not installed and used in accordance with the instructions, may cause harmful interference to radio communications. However, there is no guarantee that interference will not occur in a particular installation. If this equipment does cause harmful interference to radio or television reception, which can be determined by turning the equipment off and on, the user is encouraged to try to correct the interference by one of the following measures:

- Reorient or relocate the receiving antenna.
- Increase the separation between the equipment and receiver
- Connect the equipment into an outlet on a circuit different from that to which the receiver is connected.
- Consult the dealer or an experienced radio/TV technician for help.

Any changes or modifications not expressly approved by the party responsible for compliance could void the user's authority to operate this equipment. This transmitter must not be co-located or operating in conjunction with any other antenna or transmitter.

List of applicable FCC rules

This module has been tested and found to comply with part 22, part 24, part 27, part 90 requirements for Modular Approval.

The modular transmitter is only FCC authorized for the specific rule parts (i.e., FCC transmitter rules) listed on the grant, and that the host product manufacturer is responsible for compliance to any other FCC rules that apply to the host not covered by the modular transmitter grant of certification. If the grantee markets their product as being Part 15 Subpart B compliant (when it also contains unintentional-radiator digital circuitry), then the grantee shall provide a notice stating that the final host product still requires Part 15 Subpart B compliance testing with the modular transmitter installed.

This device is intended only for OEM integrators under the following conditions: (For module device use)

- 1) The antenna must be installed such that 20 cm is maintained between the antenna and users, and
- 2) The transmitter module may not be co-located with any other transmitter or antenna.

As long as 2 conditions above are met, further transmitter test will not be required. However, the OEM integrator is still responsible for testing their end-product for any additional compliance requirements required with this module installed.

Radiation Exposure Statement

This equipment complies with FCC radiation exposure limits set forth for an uncontrolled environment. This equipment should be installed and operated with minimum distance 20 cm between the radiator & your body.