



Honour Electronic

Code

H085

Page

1/8

Product Approval Sheet

Customer: Guangdong Litongwei New Energy Co. LTD

Model: H08501

Cust. P/N: 3.13090000001

Spec.: 20.5*39*0.08*75*10TS+G40+lead45mm

Sample Qty: 5PCS

Date: 2022-12-6

Inner signatures

Customer Signatures

Prepared By:	Jing Jing Li	Precheck By:	
Checked By:	Qing Bo Lian	Checked By:	
Approved By:	Vincent Wong	Approved By:	

Dong Guan Honour Electronic Co.,Ltd.

Product type

Wireless
Charging Coil

[Http://www.forewell-tech.com](http://www.forewell-tech.com)

Ver.

A

	Product Specification		Model	H08501
			Ver.	A/0
			Page	2/8
Customer Code	H085	Product Name	TX-Wireless Charging Coil	
<h1>Contents</h1>				
1.Cover			1
2.Catalogue			2
3.Revision history			3
4.Size			4
5.Sample			5
6.Full Size			6
7.Process Flow Diagram			7
Dong Guan Honour Electronic Co.,Ltd.		Prduct Type		Wireless Charging coil
Http://www.forewell-tech.com		Ver.		A

	Product Specification		Model	H08501
			Ver.	A/0
			Page	3/8
Customer Code	H085	Product Name	TX-Wireless Charging Coil	
Specification	20.5*39*0.08*75*10TS+G40+lead45mm	Winding Direction	CCW	
Document issue record				
Ver.	Modify Desc.		Issue Date	
A/0	First Issue		2022-12-6	
Dong Guan Honour Electronic Co.,Ltd.		Prodct Type		Wireless Charging coil
Http://www.forewell-tech.com		Ver.		A

Document Code: HN-PE-007

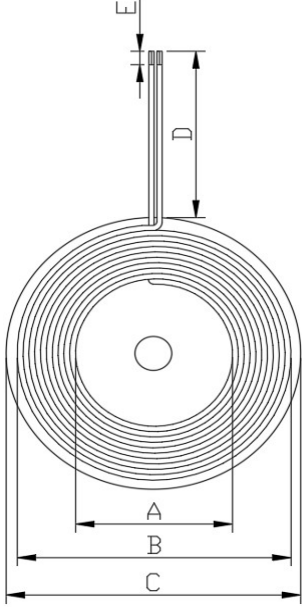
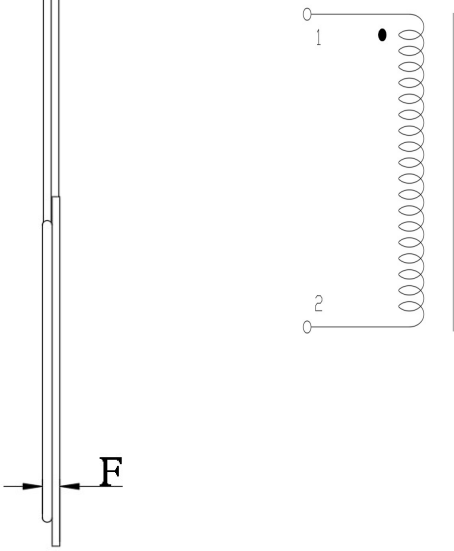
	<h1>Product Specification</h1>		Model	H08501				
			Ver.	A/0				
			Page	4/8				
Customer Code	H085		Product Name	TX-Wireless Charging Coil				
Specification	20.5*39*0.08*75*10TS+G40+lead45mm		Winding Direction	CCW				
I. Product Size (Unit: MM)			II. SCHEMATIC					
						Item	Size	Tol.
						A	20.50	±0.5
						B	39.00	±1.0
						C	40.00	±1
						D	45.00	±1.5
						E	2-5	
						F	2.30	±0.2
III. Winding Specification:								
Wdg Type		Wire		Wire OD		Turns	Layer	
CCW		1	2	0.08*75P Litz Wire		10	1	
IV. Electrical specifications								
Properties		Test conditions		Value		Unit	TOL.	
LS		100KHZ/1V		6.3		μH	10%	
DCR		25°C		75.0		mΩ	MAX	
Q值		100KHZ/1V		50.0			MIN	
V. Material list								
NO.	Material List			Spec.		Brand		
1	Litz Wire			0.08*75		Huaye 2UEW		
2	Ferrite			40*1.0*5.0		LINGZE PC40		
3	Double tape			39*6.0		HUANGGUAN		
4	Yellow gule					Sanhe SH6060		
5	High temperature tin			High temperature tin		XingWei		
Dong Guan Honour Electronic Co.,Ltd.				Product type		Wireless Charging coil		
Http://www.forewell-tech.com				Ver.		A		

	Product Specification		Model	H08501
			Ver.	A/0
			Page	5/8
Customer Code	H085	Product Name	TX-Wireless Charging Coil	
Specification	20.5*39*0.08*75*10TS+G40+lead45mm	Winding Direction	CCW	

Sample Picture



Dong Guan Honour Electronic Co.,Ltd.	Product type	Wireless Charging coil
Http://www.forewell-tech.com	Ver.	A

Document Code: HN-PE-007

Dong Guan Honour Electronic Co., Ltd

Process Flow Chart

Client		Guangdong Litongwei New Energy Co. LTD	Part	20.5*39*0.08*75*10 TS+G40+lead45mm	Part No.	H08501	A/O Rev.	
Flow Process	No.	Process	Production Shop	Equipment		Remark		
Start	1	Picking and preheating machine	Winding workshop	Wingding machine				
▽	2	Start Winding	Winding workshop	Wingding machine				
○	3	First sample inspection and confirmation of performance	Winding workshop & QC	Wingding machine & testing tool				
○	4	Wingding production	production wokshop	Wingding machine				
○	5	Cute lead wire	production wokshop	Tool				
○	6	Tin	production wokshop	Tin Tool				
○	7	Paste double tape	production wokshop	Tool				
○	8	Paste ferrite	production wokshop	Tool				
○	9	PQC inspection	QC	Calipers, LCR, Ruler				
○	10	Inspection & pack	production wokshop	Calipers, Ruler				
○	11	QA inspection	QC	Calipers, LCR, Ruler				
○	12	Passed	QC					
○	13							
○	14							
○	15							
○	16							
○	17							
○	18							

Prepared by : JingJing Li

Approved by : Qing Bo Lian