

Precept Touch – Certification Label

The label design is described in 5019.pdf:

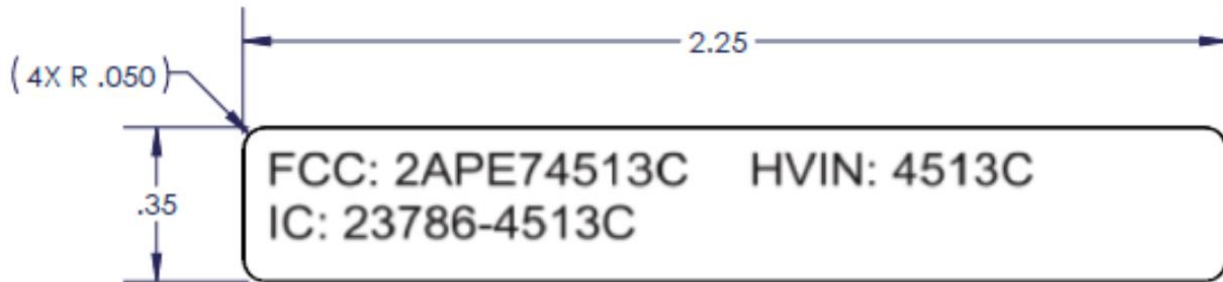

The label will be attached to the flat step feature underneath the battery holder, visible to the user whenever the batteries are changed, as shown on page 2 of 4646.OX.PDF in quadrant D2:

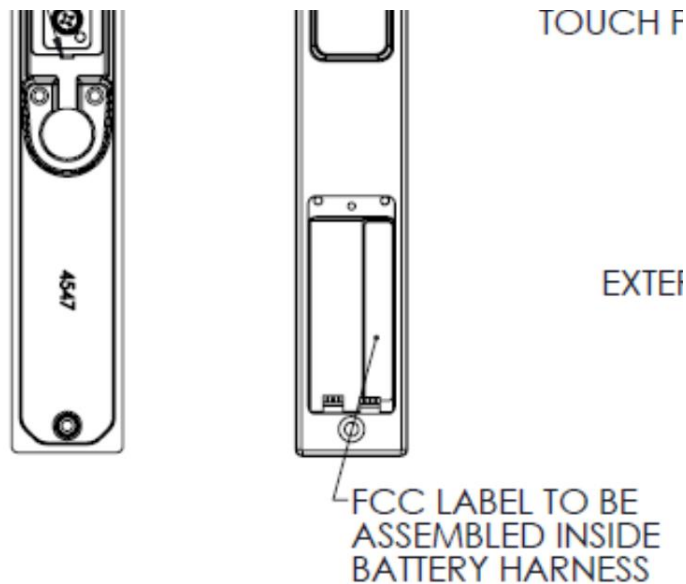

The label and adhesive material is defined in MS022714.pdf