



FCC Test Report

**Test Report
On Behalf of
ShangXing Technology(ShenZhen) Co.,Ltd.
For
3-in-1 Foldable Magnetic Wireless Charger
Model No.: X63, X63S**

FCC ID: 2APDM-X63

Prepared For : ShangXing Technology(ShenZhen) Co.,Ltd.
Room 408, 4th Floor, Building 30.Wisdomland Business Park, Guankou 2nd
road, Nantou, Nanshan, Shenzhen, China

Prepared By : Shenzhen DL Testing Technology Co., Ltd.
101-201, Building C, Shuanghuan, No.8, Baoqing Road, Baolong Industrial
Zone, Baolong Street, Longgang District, Shenzhen, Guangdong, China

Date of Test: Mar. 19, 2024 ~ Apr. 01, 2024

Date of Report: Apr. 01, 2024

Report Number: DL-240604005-1ER



Test Result Certification

Applicant's Name : ShangXing Technology(ShenZhen) Co.,Ltd.
Address : Room 408, 4th Floor, Building 30.Wisdomland Business Park,
 Guankou 2nd road, Nantou, Nanshan, Shenzhen, China

Manufacturer's Name : ShangXing Technology(ShenZhen) Co.,Ltd.
Address : Room 408, 4th Floor, Building 30.Wisdomland Business Park,
 Guankou 2nd road, Nantou, Nanshan, Shenzhen, China

Product Description

Trade Mark : N/A
Product Name : 3-in-1 Foldable Magnetic Wireless Charger
Model and/or Type Reference: X63, X63S

Standards : FCC CFR 47 PART 18

This publication may be reproduced in whole or in part for non-commercial purposes as long as the Shenzhen DL Testing Technology Co., Ltd. is acknowledged as copyright owner and source of the material. Shenzhen DL Testing Technology Co., Ltd. takes no responsibility for and will not assume liability for damages resulting from the reader's interpretation of the reproduced material due to its placement and context.

Date of Test :
Date (s) of performance of tests : **Mar. 19, 2024 ~ Apr. 01, 2024**
Date of Issue : **Apr. 01, 2024**
Test Result : **Pass**

Testing Engineer *Randy Xie*

 Randy Xie

Technical Manager *Jack Bu*

 Jack Bu

Authorized Signatory *Jade Yang*

 Jade Yang





Table of Contents	Page
1 . Test Summary	5
1.1 . Test Procedures and Results	5
1.2 . Information of the Test Laboratory	5
1.3 . Measurement Uncertainty	5
2. General Information	6
2.1. General Description of EUT	6
2.2. Carrier Frequency of Channels	7
2.3. Test Mode	8
2.4. Description of Test Setup	9
2.5. Description of Support Units	10
2.6. Measurement Instruments List	11
3. Conducted Emission Test	12
3.1. Block Diagram of Test Setup	12
3.2. Conducted Power Line Emission Limit	12
3.3. Test Procedure	12
4. Radiated Emissions	15
4.1. Block Diagram of Test Setup	15
4.2. Rules and Specifications	16
4.3. Test Procedure	16
4.4. Test Result	16
5. Antenna Requirement	22
6. Photographs of Test	23
7. Photos of the EUT	25



**** Modified History ****

Revision	Description	Issued Data	Remark
Revision 1.0	Initial Test Report Release	Apr. 01, 2024	



1. Test Summary

1.1. Test Procedures and Results

Description of Test	Section Number	Result
Conducted Emissions Test	18.307	COMPLIANT
Radiated Emission Test	18.305	COMPLIANT

Note:

1. PASS: Test item meets the requirement.
2. Fail: Test item does not meet the requirement.
3. N/A: Test case does not apply to the test object.
4. The test result judgment is decided by the limit of test standard.

1.2. Information of the Test Laboratory

Shenzhen DL Testing Technology Co., Ltd.

Add.: 101-201, Building C, Shuanghuan, No.8, Baoqing Road, Baolong Industrial Zone, Baolong Street, Longgang District, Shenzhen, Guangdong, China

Testing Laboratory Authorization:

FCC Test Firm Registration Number: 854456

Designation Number: CN1307

IC Registered No.: 27485

CAB ID.: CN0118

1.3. Measurement Uncertainty

Measurement Uncertainty

Conducted Emission Expanded Uncertainty = 2.71dB, k=2

Radiated emission expanded uncertainty(9kHz-30MHz) = 3.90dB, k=2

Radiated emission expanded uncertainty(30MHz-1000MHz) = 3.90dB, k=2

Radiated emission expanded uncertainty(Above 1GHz) = 4.28dB, k=2



2. General Information

2.1. General Description of EUT

Equipment:	3-in-1 Foldable Magnetic Wireless Charger
Model Name:	X63
Series Models:	X63S
Model Difference:	All model's the function, software and electric circuit are the same, only with product model named different. Test sample model: X63.
Trade Mark:	N/A
FCC ID:	2APDM-X63
Antenna Type:	Coil Antenna
Operation Frequency:	112KHz~205KHz
Test Frequency:	Mobile Phone: 145KHz Earphone: 128KHz Watch: 128KHz
Modulation Type:	ASK
Power Source:	Input: DC5V/3A, 9V/2.22A, 12V/3A Output: Magnetic Wireless Charger: 5W/7.5W/10W/15W AirPods Charger: 5W Apple Watch Charger: 3W/5W
Power Rating:	Input: DC5V/3A, 9V/2.22A, 12V/3A Output: Magnetic Wireless Charger: 5W/7.5W/10W/15W AirPods Charger: 5W Apple Watch Charger: 3W/5W
Note:	<ol style="list-style-type: none">1. The transfer system includes three coils, 3 coils can work individually or can work at the same time. All situations have been tested, only the worst situation was recorded in the report.2. For a more detailed features description, please refer to the manufacturer's specifications or the User's Manual.3. The cable loss data is obtained from the supplier.4. The test results in the report only apply to the tested sample.



2.2. Carrier Frequency of Channels

Operation Frequency each of channel	
Channel	Frequency
01	145KHz
02	128KHz
03	128KHz



2.3. Test Mode

Test Item	Test Mode	Description
Radiated & Conducted Test Cases	Mode 1	AC/DC Adapter + EUT + Wireless load 1 (Full load) + Wireless load 2 (Full load) + Wireless load 3 (Full load)
	Mode 2	AC/DC Adapter + EUT + Wireless load 1 (Half load) + Wireless load 2 (Half load) + Wireless load 3 (Full load)
	Mode 3	AC/DC Adapter + EUT + Wireless load 1 (Null load) + Wireless load 2 (Null load) + Wireless load 3 (Full load)
	Mode 4	AC/DC Adapter + EUT + Wireless load 1 (Full load) + Wireless load 2 (Full load) + Wireless load 3 (Half load)
	Mode 5	AC/DC Adapter + EUT + Wireless load 1 (Half load) + Wireless load 2 (Half load) + Wireless load 3 (Half load)
	Mode 6	AC/DC Adapter + EUT + Wireless load 1 (Null load) + Wireless load 2 (Null load) + Wireless load 3 (Half load)
	Mode 7	AC/DC Adapter + EUT + Wireless load 1 (Full load) + Wireless load 2 (Full load) + Wireless load 3 (Null load)
	Mode 8	AC/DC Adapter + EUT + Wireless load 1 (Half load) + Wireless load 2 (Half load) + Wireless load 3 (Null load)
	Mode 9	AC/DC Adapter + EUT + Wireless load 1 (Null load) + Wireless load 2 (Null load) + Wireless load 3 (Null load)
	Mode 10	AC/DC Adapter + EUT + Wireless load 1 (Full load)
	Mode 11	AC/DC Adapter + EUT + Wireless load 1 (Half load)
	Mode 12	AC/DC Adapter + EUT + Wireless load 1 (Null load)
	Mode 13	AC/DC Adapter + EUT + Wireless load 2 (Full load)
	Mode 14	AC/DC Adapter + EUT + Wireless load 2 (Half load)
	Mode 15	AC/DC Adapter + EUT + Wireless load 2 (Null load)
	Mode 16	AC/DC Adapter + EUT + Wireless load 3 (Full load)
	Mode 17	AC/DC Adapter + EUT + Wireless load 3 (Half load)
	Mode 18	AC/DC Adapter + EUT + Wireless load 3 (Null load)
	Mode 19	AC/DC Adapter + EUT (Null Load)

Note: 1. All modes and configurations above have been tested, the report only shows the worst-case.
 2. For Radiated Emission, 3axis were chosen for testing for each applicable mode, including the mobile phone in vertical and horizontal positions.
 3. The wireless load replaces the Mobile Phone by Lab.
 4. According to the manufacturer's design principle, the wireless charging power will reach its maximum when the client device's battery level is between 1% and 10%.



2.4. Description of Test Setup

Operation of EUT during Testing:

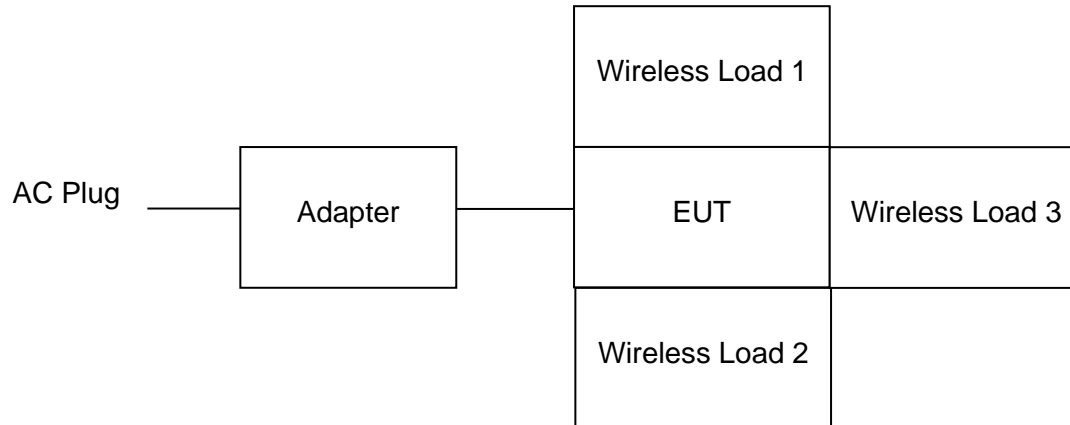

The sample was placed (0.8m (30MHz~1GHz), 0.8m (9KHz~30MHz)) above the ground plane of 3m chamber. Measurements in both horizontal and vertical polarities were performed. During the test, each emission was maximized by: having the EUT continuously working, investigated all operating modes, rotated about all 3 axis (X, Y & Z) and considered typical configuration to obtain worst position, manipulating interconnecting cables, rotating the turntable, varying antenna height from 1m to 4m in both horizontal and vertical polarizations. The emissions worst-case are shown in Test Results of the following pages. The worst case is X position.



2.5. Description of Support Units

The EUT has been tested as an independent unit together with other necessary accessories or support units. The following support units or accessories were used to form a representative test configuration during the tests.

Item	Equipment	Trade Mark	Model/Type No.	Specification	Remark
1	3-in-1 Foldable Magnetic Wireless Charger	N/A	X63	N/A	EUT
2	Adapter	N/A	191106C	Input: AC100-240V, 1.8A, 50/60Hz Output: DC5V/3A, 9V3A, 12V/3A, 15V/3A, 20V/3.25A, (65W Max)	Peripheral
3	USB Cable	N/A	N/A	Length: 1.0m	Peripheral
4	Wireless Load 1	YBZ	N/A	Wireless input 15W	Peripheral
5	Wireless Load 2	YBZ	N/A	Wireless input 5W	Peripheral
6	Wireless Load 3	YBZ	N/A	Wireless input 5W	Peripheral

Note:

1. All the equipment/cables were placed in the worst-case configuration to maximize the emission during the test.
2. Grounding was established in accordance with the manufacturer's requirements and conditions for the intended use.
3. For conducted measurements (Output Power, 6dB Emission Bandwidth, Power Spectral Density, Spurious Emissions), the antenna of EUT is connected to the test equipment via temporary antenna connector, the antenna connector is soldered on the antenna port of EUT, and the temporary antenna connector is listed in the Test Instruments.

**2.6. Measurement Instruments List**

Radiation test, Band-edge test and 20db bandwidth test equipment

Item	Equipment	Manufacturer	Type No.	Serial No.	Last calibration	Calibrated until
1	Spectrum Analyzer (9kHz-26.5GHz)	Agilent	E4408B	MY50140780	Nov. 04, 2023	Nov. 03, 2024
2	Test Receiver (9kHz-7GHz)	R&S	ESRP7	101393	Nov. 04, 2023	Nov. 03, 2024
3	Bilog Antenna (30MHz-1GHz)	R&S	VULB9162	00306	Nov. 04, 2023	Nov. 03, 2024
4	Horn Antenna (1GHz-18GHz)	Schwarzbeck	BBHA9120D	02139	Nov. 04, 2023	Nov. 03, 2024
5	Horn Antenna (18GHz-40GHz)	A.H. Systems	SAS-574	588	Nov. 04, 2023	Nov. 03, 2024
6	Amplifier (9KHz-6GHz)	Schwarzbeck	BBV9743B	00153	Nov. 04, 2023	Nov. 03, 2024
7	Amplifier (1GHz-18GHz)	EMEC	EM01G8GA	00270	Nov. 04, 2023	Nov. 03, 2024
8	Amplifier (18GHz-40GHz)	Quanjuda	DLE-161	97	Nov. 04, 2023	Nov. 03, 2024
9	Loop Antenna (9KHz-30MHz)	Schwarzbeck	FMZB1519B	00014	Nov. 04, 2023	Nov. 03, 2024
10	RF cables1 (9kHz-1GHz)	ChengYu	966	004	Nov. 04, 2023	Nov. 03, 2024
11	RF cables2 (1GHz-40GHz)	ChengYu	966	003	Nov. 04, 2023	Nov. 03, 2024
12	Antenna connector	Florida RF Labs	N/A	RF 01#	Nov. 04, 2023	Nov. 03, 2024
13	Power probe	KEYSIGHT	U2021XA	MY55210018	Nov. 04, 2023	Nov. 03, 2024
14	Signal Analyzer 9kHz-26.5GHz	Agilent	N9020A	MY55370280	Nov. 04, 2023	Nov. 03, 2024
15	Test Receiver 20kHz-40GHz	R&S	ESU 40	100376	Nov. 04, 2023	Nov. 03, 2024
16	D.C. Power Supply	LongWei	PS-305D	010964729	Nov. 04, 2023	Nov. 03, 2024

Conduction Test equipment

Item	Equipment	Manufacturer	Type No.	Serial No.	Last calibration	Calibrated until
1	843 Shielded Room	ChengYu	843 Room	843	Sep. 20, 2022	Sep. 19, 2025
2	EMI Receiver	R&S	ESR	101421	Nov. 04, 2023	Nov. 03, 2024
3	LISN	R&S	ENV216	102417	Nov. 04, 2023	Nov. 03, 2024
4	843 Cable 1#	ChengYu	CE Cable	001	Nov. 04, 2023	Nov. 03, 2024
5	10dB Attenuator	Schwarzbeck	VTSD9561F	00154	Nov. 04, 2023	Nov. 03, 2024

Other

Item	Name	Manufacturer	Model	Software version
1	EMC Conduction Test System	FALA	EZ_EMCC	EMC-CON 3A1.1
2	EMC radiation test system	FALA	EZ_EMCC	FA-03A2
3	RF test system	MAIWEI	MTS8310	2.0.0.0
4	RF communication test system	MAIWEI	MTS8200	2.0.0.0



3. Conducted Emission Test

3.1. Block Diagram of Test Setup

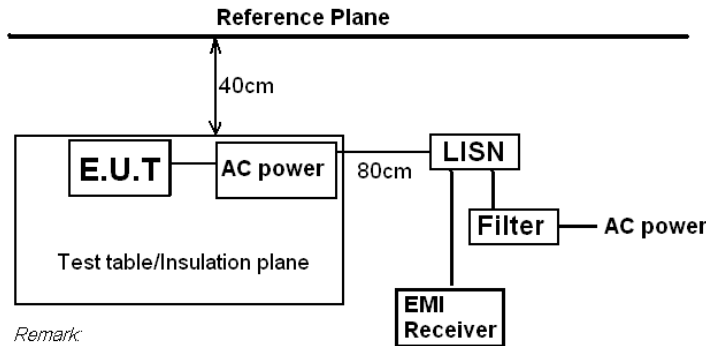

Remark
 E.U.T: Equipment Under Test
 LISN: Line Impedance Stabilization Network
 Test table height=0.8m

3.2. Conducted Power Line Emission Limit

According to FCC Part 18.307(b)

Frequency (MHz)	Maximum RF Line Voltage (dBµV)			
	CLASS A		CLASS B	
	Q.P.	Ave.	Q.P.	Ave.
0.15 - 0.50	79	66	66-56*	56-46*
0.50 - 5.00	73	60	56	46
5.00 - 30.0	73	60	60	50

* Decreasing linearly with the logarithm of the frequency

For intentional device, according to §18.307 Line Conducted Emission Limit is same as above table.

3.3. Test Procedure

1. The equipment was set up as per the test configuration to simulate typical actual usage per the user's manual. The EUT is a tabletop system, a wooden table with a height of 0.8 meters is used and is placed on the ground plane as per ANSI C63.10.
2. Support equipment, if needed, was placed as per ANSI C63.10.
3. All I/O cables were positioned to simulate typical actual usage as per ANSI C63.10.
4. If a EUT received DC power from the USB Port of Notebook PC, the PC's adapter received AC120V/60Hz power through a Line Impedance Stabilization Network (LISN) which supplied power source and was grounded to the ground plane.
5. All support equipments received AC power from a second LISN, if any.
6. The EUT test program was started. Emissions were measured on each current carrying line of the EUT using a spectrum Analyzer / Receiver connected to the LISN powering the EUT. The LISN has two monitoring points: Line 1 (Hot Side) and Line 2 (Neutral Side). Two scans were taken: one with Line 1 connected to Analyzer / Receiver and Line 2 connected to a 50 ohm load; the second scan had Line 1 connected to a 50 ohm load and Line 2 connected to the Analyzer / Receiver.
7. Analyzer / Receiver scanned from 150 KHz to 30MHz for emissions in each of the test modes.



3.4. Test Result

PASS

All the test modes completed for test. Only the worst result was reported as below:

Test Specification: Line

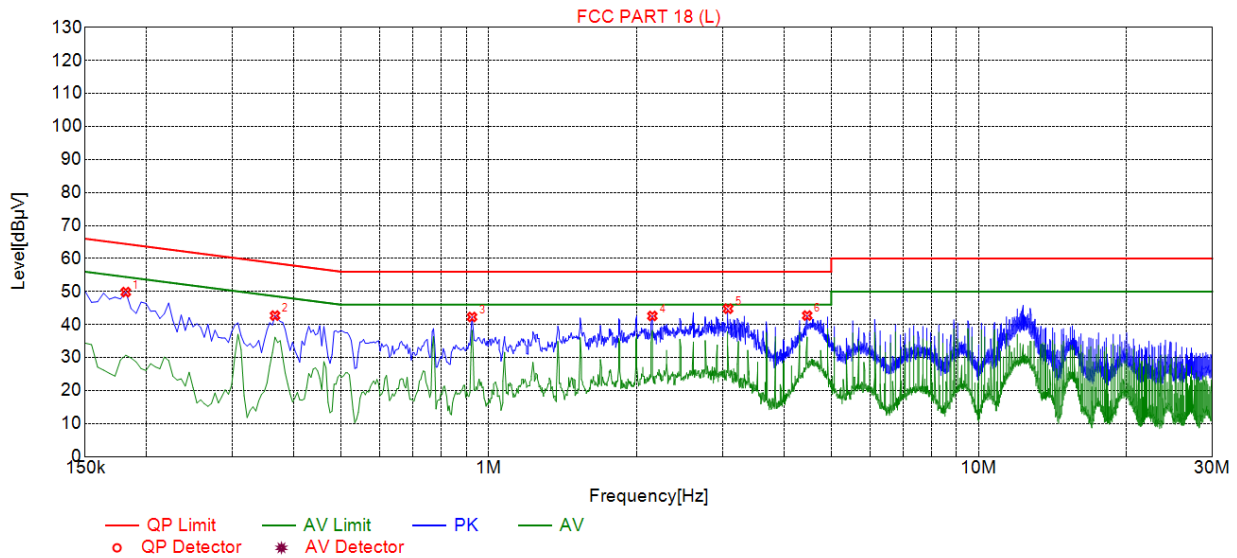

Suspected List

NO.	Freq. [MHz]	Level [dBµV]	Factor [dB]	Limit [dBµV]	Margin [dB]	Reading [dBµV]	Detector	Type
1	0.1815	49.83	20.06	64.42	14.59	29.77	PK	L
2	0.3660	42.72	20.04	58.59	15.87	22.68	PK	L
3	0.9240	42.29	20.06	56.00	13.71	22.23	PK	L
4	2.1570	42.61	20.16	56.00	13.39	22.45	PK	L
5	3.0795	44.81	20.22	56.00	11.19	24.59	PK	L
6	4.4655	42.72	20.25	56.00	13.28	22.47	PK	L

Remark: Margin = Limit – Level

Correction factor = Cable lose + LISN insertion loss

Level=Test receiver reading + correction factor



Test Specification: Neutral

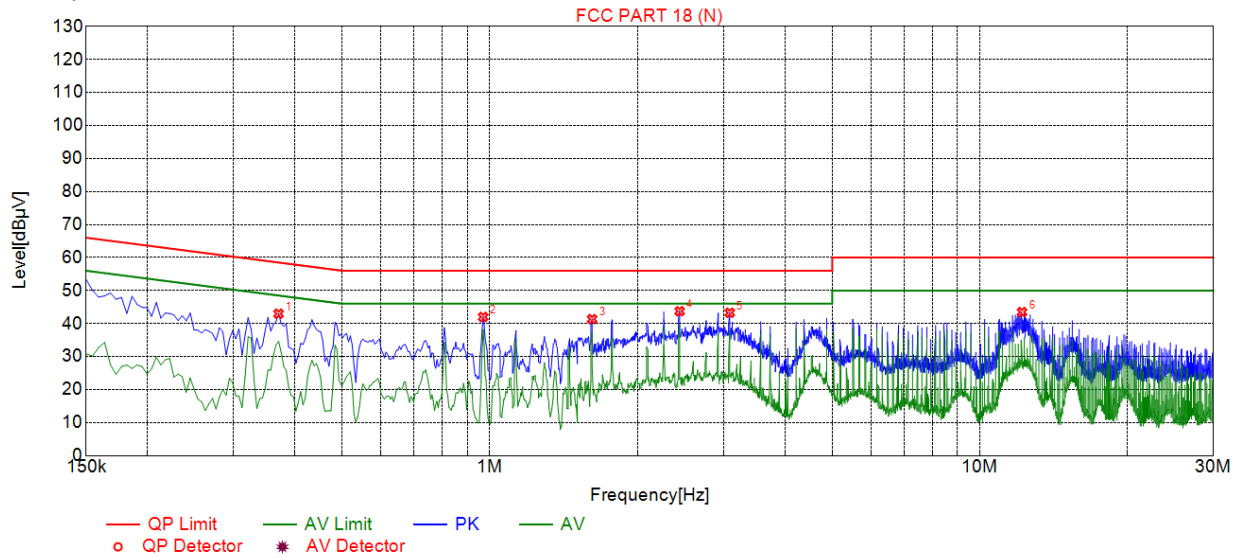

Suspected List								
NO.	Freq. [MHz]	Level [dBµV]	Factor [dB]	Limit [dBµV]	Margin [dB]	Reading [dBµV]	Detector	Type
1	0.3705	42.99	20.05	58.49	15.50	22.94	PK	N
2	0.9690	42.00	20.06	56.00	14.00	21.94	PK	N
3	1.6170	41.34	20.11	56.00	14.66	21.23	PK	N
4	2.4405	43.74	20.18	56.00	12.26	23.56	PK	N
5	3.0885	43.26	20.22	56.00	12.74	23.04	PK	N
6	12.2010	43.47	19.99	60.00	16.53	23.48	PK	N

Remark: Margin = Limit – Level

Correction factor = Cable lose + LISN insertion loss

Level=Test receiver reading + correction factor



4. Radiated Emissions

4.1. Block Diagram of Test Setup

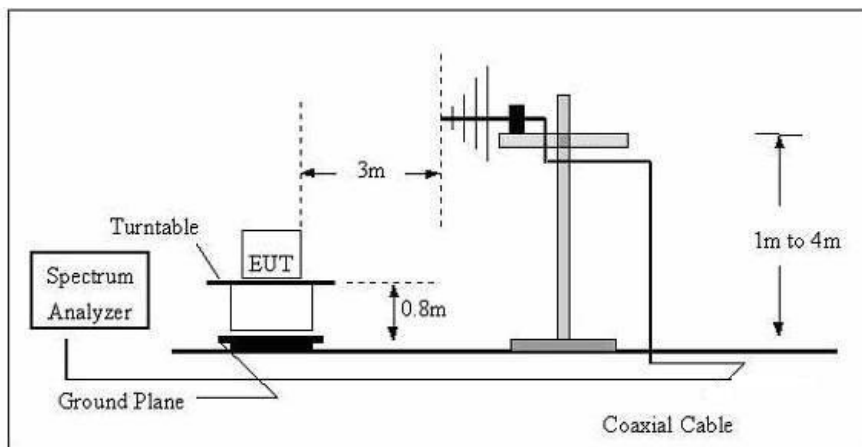
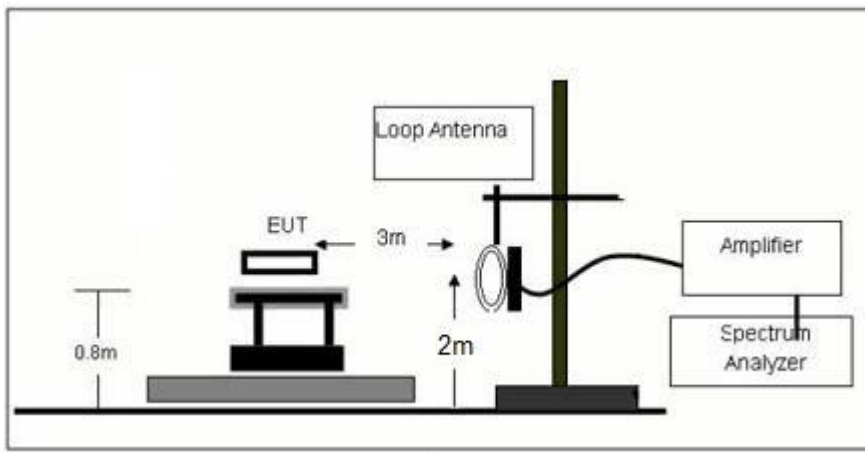



4.2. Rules and Specifications

Except as provided elsewhere in this Subpart 18.305 (b), the field strength levels of emissions which lie outside the bands specified in §18.301, unless otherwise indicated, shall not exceed the following table:

Equipment	Operating frequency	RF Power generated by equipment (watts)	Field strength limit (uV/m)	Distance (meters)
(miscellaneous)				
	Any non-ISM frequency	Below 500 500 or more	15 15 × SQRT(power/500)	300 1300

Remark:

- (1) Emission level dBuV/m for 0.009~30MHz = $20\log(15) + 40\log(300/3)$ dBuV/m;
- (2) Calculated according FCC 18.305.
- (3) The smaller limit shall apply at the cross point between two frequency bands.
- (4) Distance is the distance in meters between the measuring instrument, antenna and the closest point of any part of the device or system.

4.3. Test Procedure

Measurement distance 3m

For the measurement range up to 30MHz in the following plots the field strength result from 3m
Distance measurements are extrapolated to 300m and 30m distance respectively, by 40dB/decade, Per antenna factor scaling.

Measurements below 1000MHz are performed with a peak detector and compared to average limits,
Measurements with an average detector are not required.

Note:

For battery operated equipment, the equipment tests shall be performed using a new battery.

4.4. Test Result

PASS



For 9KHz - 30MHz

Mobile phone:

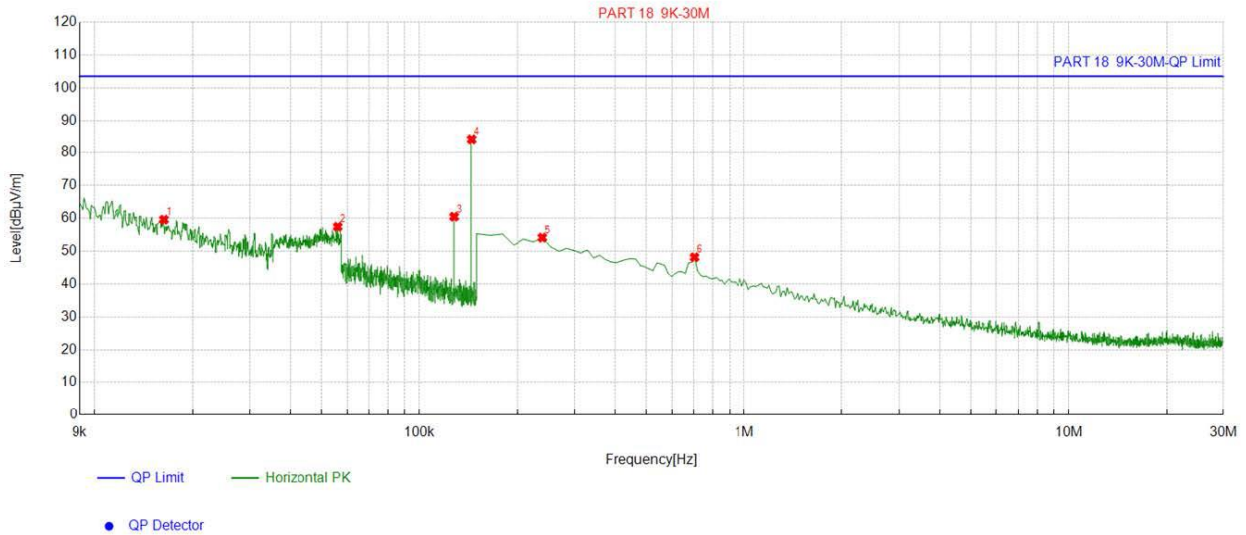

Suspected List						
NO.	Freq. [MHz]	Factor [dB]	Reading [dBµV/m]	Level [dBµV/m]	Limit [dBµV/m]	Margin [dB]
1	0.016336	15.32	44.26	59.58	103.50	43.92
2	0.056118	13.95	43.50	57.45	103.50	46.05
3	0.127711	13.78	46.73	60.51	103.50	42.99
4	0.144569	13.77	70.81	84.58	103.50	18.92
5	0.239595	13.68	40.44	54.12	103.50	49.38
6	0.702501	13.81	34.35	48.16	103.50	55.34

Remark: Factor = Cable loss + Antenna factor + Attenuator – Pre-amplifier; Level = Reading + Factor; Margin = Limit – Level;



Earphone:

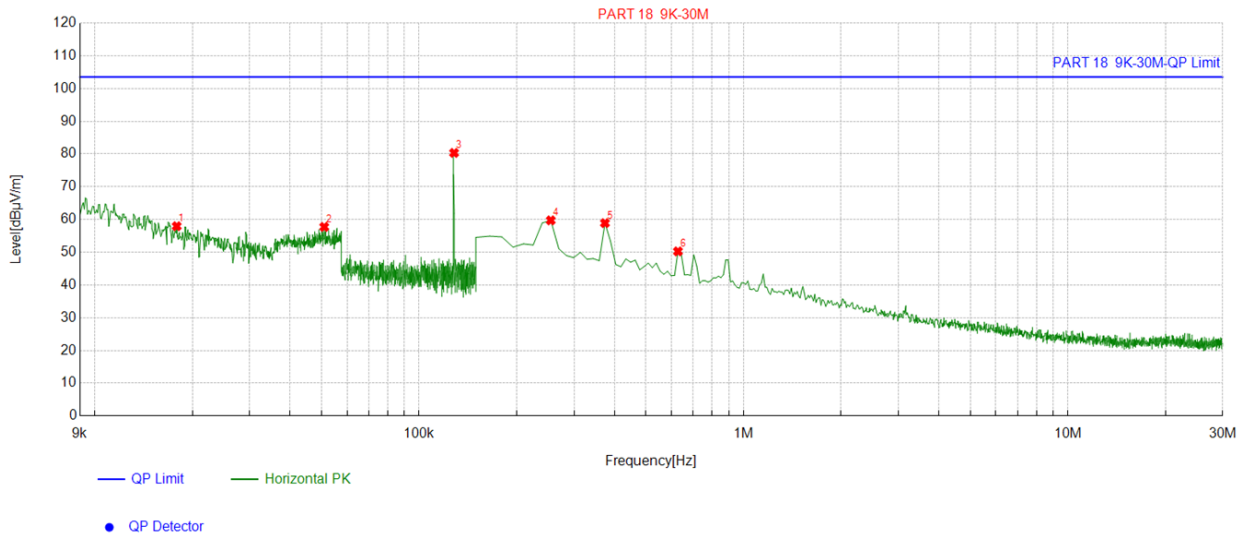

Suspected List						
NO.	Freq. [MHz]	Factor [dB]	Reading [dBµV/m]	Level [dBµV/m]	Limit [dBµV/m]	Margin [dB]
1	0.017887	14.99	42.96	57.95	103.50	45.55
2	0.050968	13.92	43.81	57.73	103.50	45.77
3	0.128134	13.78	66.55	80.33	103.50	23.17
4	0.254527	13.68	46.06	59.74	103.50	43.76
5	0.373987	13.76	45.14	58.90	103.50	44.60
6	0.627839	13.74	36.52	50.26	103.50	53.24

Remark: Factor = Cable loss + Antenna factor + Attenuator – Preamplifier; Level = Reading + Factor; Margin = Limit – Level;



Watch:

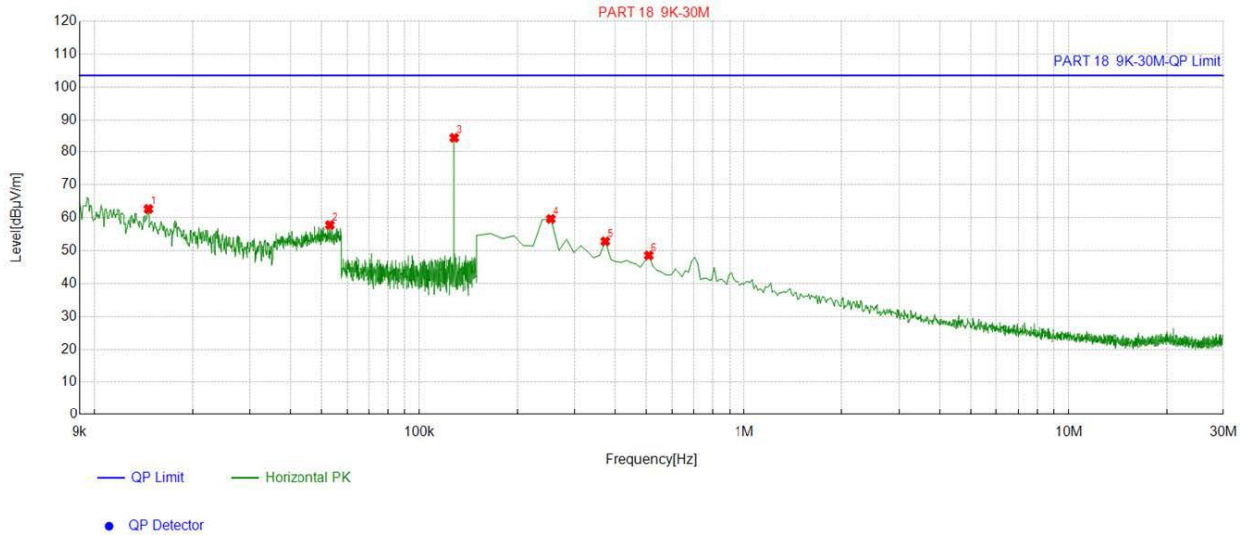

Suspected List						
NO.	Freq. [MHz]	Factor [dB]	Reading [dBµV/m]	Level [dBµV/m]	Limit [dBµV/m]	Margin [dB]
1	0.014643	15.68	46.98	62.66	103.50	40.84
2	0.053085	13.93	43.85	57.78	103.50	45.72
3	0.127781	13.78	70.49	84.27	103.50	19.23
4	0.254527	13.68	45.96	59.64	103.50	43.86
5	0.373987	13.76	39.07	52.83	103.50	50.67
6	0.508379	13.73	34.83	48.56	103.50	54.94

Remark: Factor = Cable loss + Antenna factor + Attenuator – Preamplifier; Level = Reading + Factor; Margin = Limit – Level;



For 30MHz-1GHz

Antenna polarity: H

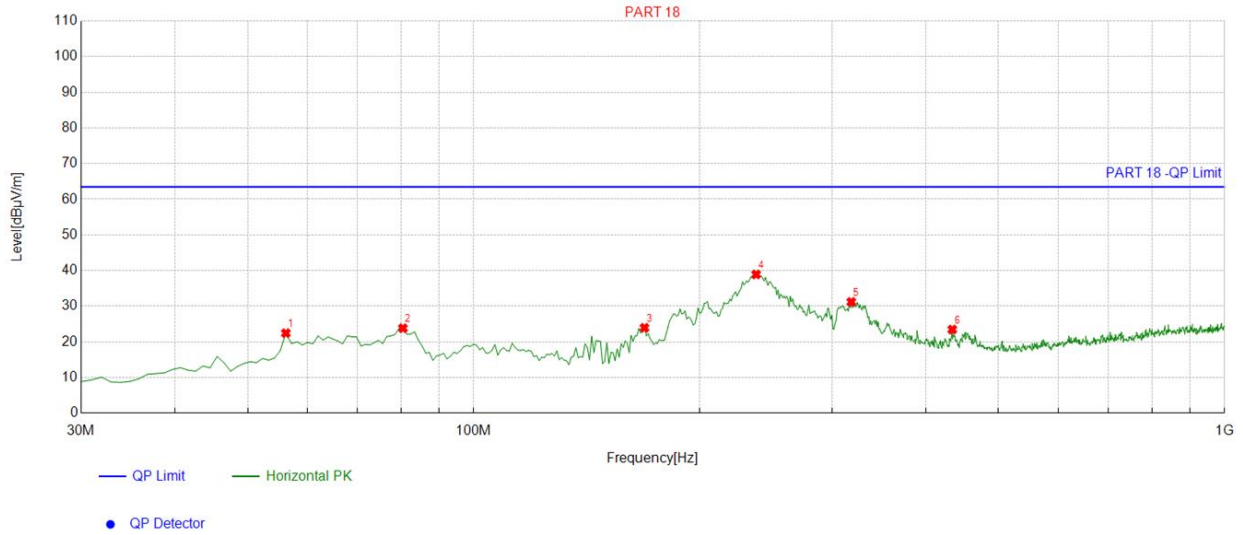

Suspected List									
NO.	Freq. [MHz]	Factor [dB]	Reading [dBµV/m]	Level [dBµV/m]	Limit [dBµV/m]	Margin [dB]	Height [cm]	Angle [°]	Polarity
1	56.216216	-14.40	36.86	22.46	63.50	41.04	100	179	Horizontal
2	80.49049	-17.44	41.27	23.83	63.50	39.67	100	168	Horizontal
3	168.84884	-17.09	41.04	23.95	63.50	39.55	100	314	Horizontal
4	237.78778	-13.37	52.28	38.91	63.50	24.59	100	85	Horizontal
5	318.37837	-11.71	42.91	31.20	63.50	32.30	100	248	Horizontal
6	433.92392	-8.21	31.67	23.46	63.50	40.04	100	132	Horizontal

Remark: Factor = Cable loss + Antenna factor + Attenuator – Pre-amplifier; Level = Reading + Factor; Margin = Limit – Level;



Antenna polarity: V

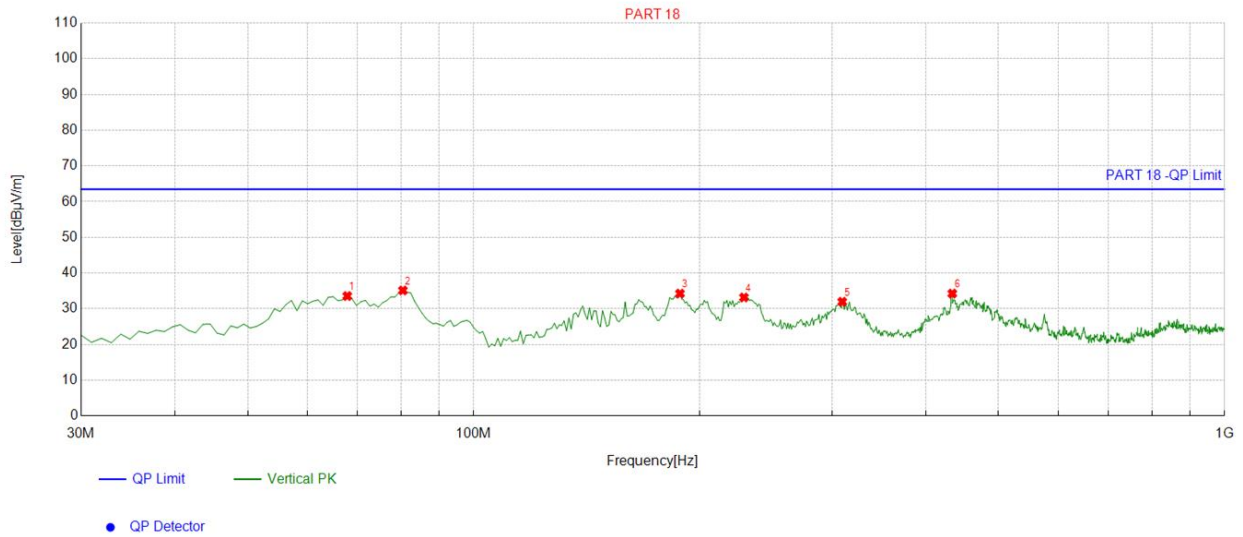

Suspected List									
NO.	Freq. [MHz]	Factor [dB]	Reading [dBµV/m]	Level [dBµV/m]	Limit [dBµV/m]	Margin [dB]	Height [cm]	Angle [°]	Polarity
1	67.867868	-15.38	48.95	33.57	63.50	29.93	100	296	Vertical
2	80.49049	-17.44	52.58	35.14	63.50	28.36	100	206	Vertical
3	188.26826	-16.93	51.20	34.27	63.50	29.23	100	222	Vertical
4	229.04904	-13.95	47.12	33.17	63.50	30.33	100	358	Vertical
5	309.63964	-11.84	43.81	31.97	63.50	31.53	100	219	Vertical
6	433.92392	-8.21	42.48	34.27	63.50	29.23	100	130	Vertical

Remark: Factor = Cable loss + Antenna factor + Attenuator – Preamplifier; Level = Reading + Factor; Margin = Limit – Level;

5. Antenna Requirement

Refer to statement below for compliance.

The manufacturer may design the unit so that the user can replace a broken antenna, but the use of a standard antenna jack or electrical connector is prohibited. Further, this requirement does not apply to intentional radiators that must be professionally installed.

Antenna Connected Construction

The antenna used in this product is Coil Antenna, which permanently attached. It conforms to the standard requirements.

Antenna

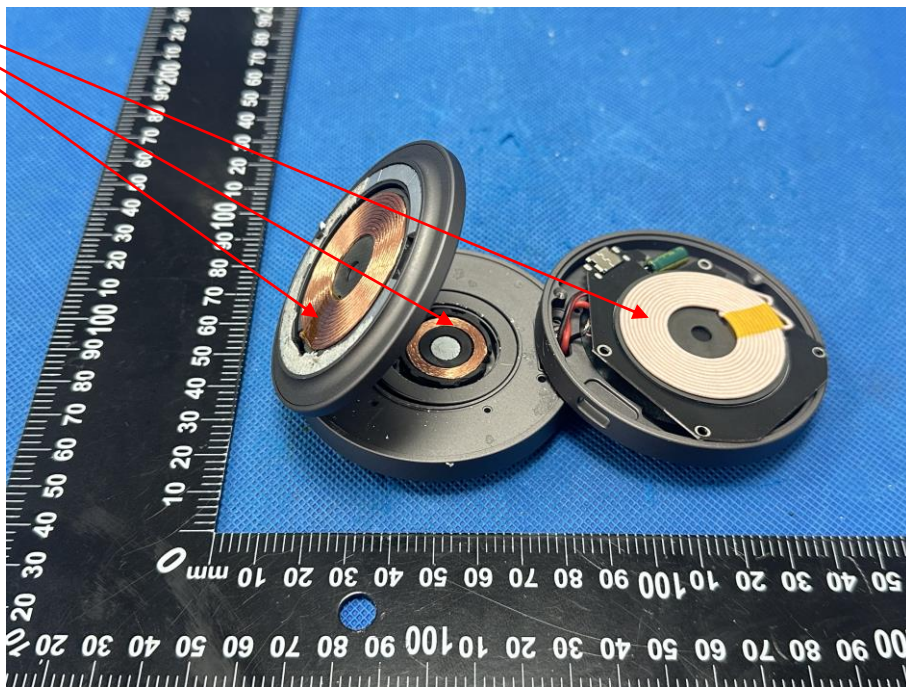



6. Photographs of Test

Radiated Emission

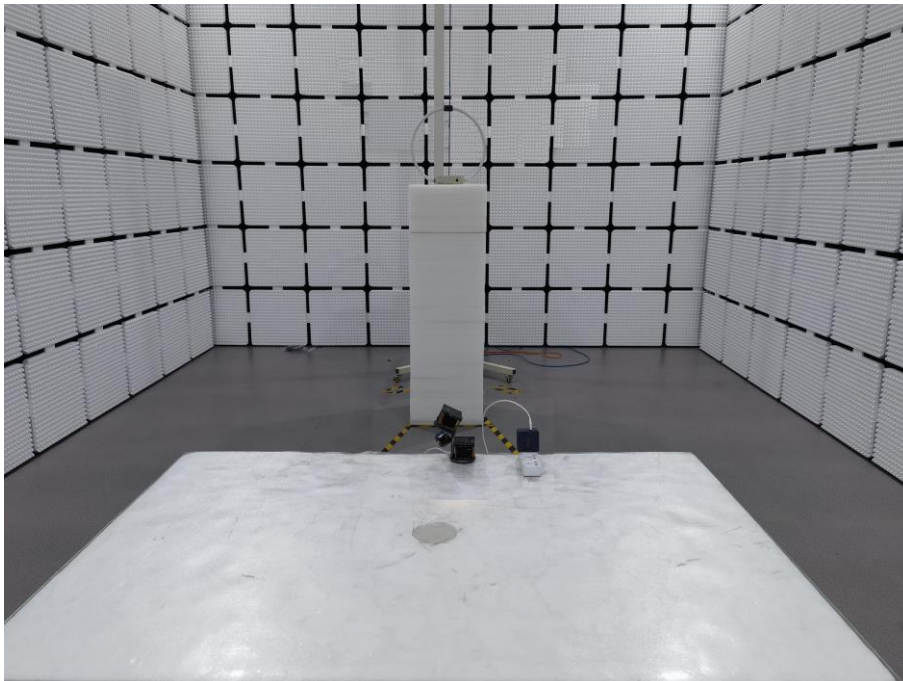



Conducted Emission

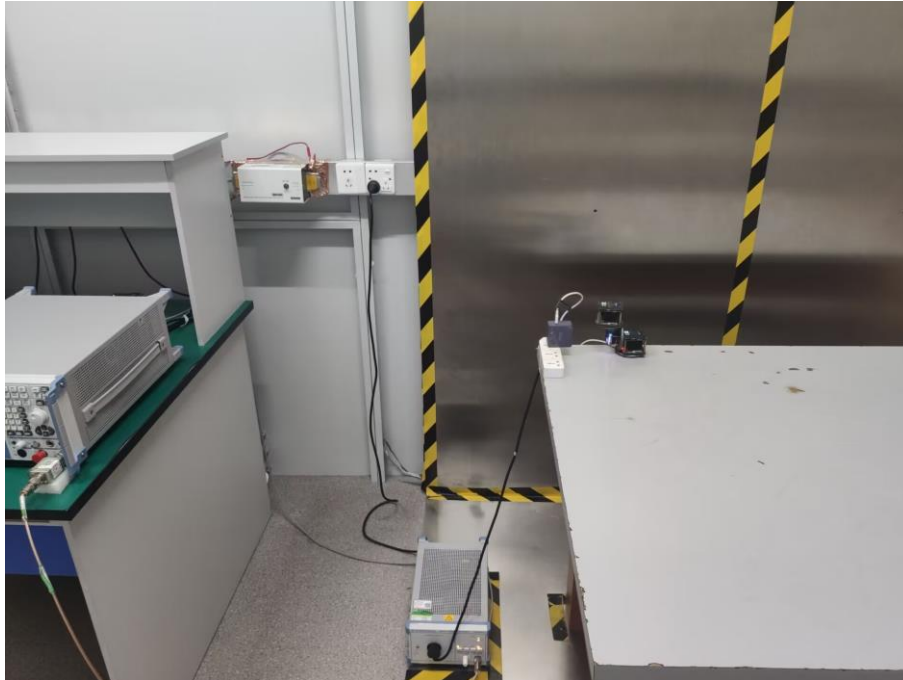



7. Photos of the EUT

Reference to the report: ANNEX A of external photos and ANNEX B of internal photos.

-----End of test report-----