



SAR TEST REPORT

APPLICANT : Hot Pepper, Inc.
PRODUCT NAME : 4G Smart Phone
MODEL NAME : H5
BRAND NAME : Hot Pepper
FCC ID : 2APD4-P26A
STANDARD(S) : 47CFR 2.1093
IEEE 1528-2013
TEST DATE : 2018-04-05 to 2018-04-17
ISSUE DATE : 2018-04-18

Tested by: *Gan Yueming*
Gan Yueming(Test engineer)

Approved by: *Peng Huarui*
Peng Huarui(Supervisor)

NOTE: This document is issued by MORLAB, the test report shall not be reproduced except in full without prior written permission of the company. The test results apply only to the particular sample(s) tested and to the specific tests carried out which is available on request for validation and information confirmed at our website.





DIRECTORY

- 1. Technical Information..... 5
 - 1.1. Applicant and Manufacturer Information..... 5
 - 1.2. Equipment Under Test (EUT) Description 5
 - 1.3. Summary of Maximum SAR Value 7
 - 1.4. Photographs of the EUT..... 8
 - 1.5. Applied Reference Documents 8
- 2. Device Category and SAR Limits 9
- 3. Specific Absorption Rate (SAR)..... 10
 - 3.1. Introduction 10
 - 3.2. SAR Definition 10
- 4. SAR Measurement Setup..... 11
 - 4.1. The Measurement System 11
 - 4.2. Probe 11
 - 4.3. Probe Calibration Process..... 13
 - 4.4. Phantom 14
 - 4.5. Device Holder 14
- 5. Measurement Procedures 15
 - 5.1. Spatial Peak SAR Evaluation..... 15
 - 5.2. Area Scan..... 16
 - 5.3. Zoom Scan..... 17
 - 5.4. Power Drift Monitoring 17
- 6. Tissue Simulating Liquids..... 18
- 7. Uncertainty Assessment..... 21
 - 7.1. Uncertainty Evaluation For EUT SAR Test 21
 - 7.2. Uncertainty For System Performance Check..... 22
- 8. SAR Measurement Evaluation 24



8.1. System Setup 24

8.2. Validation Results 25

9. RF Exposure Positions 27

9.1. Information on the testing 27

9.2. Body-worn Configurations 28

9.3. Hotspot Mode Exposure Position Conditions 28

9.4. Measurement procedure 29

9.5. Description of interpolation/extrapolation scheme 29

10. Hot-spot Mode Evaluation Procedure..... 31

11. SAR Evaluation Procedures for LTE 32

12. Measurement of Conducted output power 34

13. Test Results List 45

13.1. Test Guidance: 45

13.2. SAR Test Result 47

14. Repeated SAR Measurement 54

15. Multiple Transmitters Evaluation..... 55

Annex A Photographs of Test Setup

Annex B System Check Data

Annex C Plots of SAR Test Results

Annex D General Information

Annex E SATIMO Calibration Certificate



Change History		
Issue	Date	Reason for change
1.0	2018-04-18	First edition



1. Technical Information

Note: Provide by manufacturer.

1.1. Applicant and Manufacturer Information

Applicant:	Hot Pepper, Inc.
Applicant Address:	5151 California Ave., Suite 100, Irvine 92617, USA
Manufacturer:	Hot Pepper, Inc.
Manufacturer Address:	5151 California Ave., Suite 100, Irvine 92617, USA

1.2. Equipment Under Test (EUT) Description

Model Name:	H5
Brand Name:	Hot Pepper
Hardware Version:	T169-LK-V1.2
Software Version:	HOTPEPPER_SW01_20180320
Frequency Bands:	GSM850: 824.2 MHz ~ 848.8MHz GSM1900: 1850.2 MHz ~ 1909.8MHz WCDMA Band II: 1852.4 MHz ~ 1907.6MHz WCDMA Band IV: 1712.4 MHz ~ 1752.6MHz WCDMA Band V: 826.4 MHz ~ 846.6MHz LTE Band 2: 1850 MHz ~ 1910 MHz LTE Band 4: 1710 MHz ~ 1755 MHz LTE Band 12: 699 MHz ~ 716 MHz LTE Band 17: 704 MHz ~ 716 MHz WLAN 2.4GHz: 2412 MHz ~ 2462 MHz WLAN 5GHz Band 1: 5150 MHz ~ 5250 MHz; WLAN 5GHz Band 2: 5250 MHz ~ 5350 MHz; WLAN 5GHz Band 3: 5470 MHz ~ 5725 MHz; WLAN 5GHz Band 4: 5725 MHz ~ 5850 MHz; Bluetooth: 2402 MHz ~ 2480 MHz GPS:1575.42MHz
Modulation Mode:	GSM / GPRS: GMSK EDGE: 8PSK WCDMA: AMR/RMC12.2Kbps HSDPA/HSUPA HSPA+ LTE: QPSK / 16QAM 802.11b/g/n HT20/n HT40 802.11a/n HT20/HT40



	Bluetooth 2.1 BDR (1Mbps) : GFSK Bluetooth 2.1 EDR (2Mbps) : $\pi/4$ -DQPSK Bluetooth 2.1 EDR (3Mbps) : 8-DPSK Bluetooth 4.0 - LE (1Mbps): GFSK GPS		
Multi-slot Class:	GPRS: Multi-slot Class 12; EDGE: Multi-slot Class 12;		
Operation mode:	Class B		
Hotspot function:	Support Hotspot		
Antenna type:	WWAN : Fixed Internal Antenna WLAN : Fixed Internal Antenna Bluetooth : Fixed Internal Antenna		
Battery Model:	BL9503		
Battery specification:	2800mAh 3.85V		
SIM cards description:	For dual SIM card version, SIM 1 and SIM 2 are the same chipset unit and tested as a single chipset, the SIM 1 is chosen for test		
Max Scaled SAR-1g(W/Kg)	Head	0.723W/kg	Limit(W/kg): 1.6W/kg
	Body-worn	1.008 W/kg	
	Hotspot	1.008 W/kg	

Note: For a more detailed description, please refer to specification or user's manual supplied by the applicant and/or manufacturer.



1.3. Summary of Maximum SAR Value

Frequency Band		Highest SAR Summary		
		Head (Separation 0mm)	Body-worn (Separation 10mm)	Hotspot (Separation 10mm)
		1g SAR (W/kg)		
WWAN	GSM850	0.332	0.793	0.793
	GSM1900	0.231	0.594	0.594
	WCDMA Band II	0.304	0.626	0.626
	WCDMA Band IV	0.396	0.784	0.784
	WCDMA Band V	0.247	0.441	0.441
	LTE Band 2	0.655	0.615	0.667
	LTE Band 4	0.723	1.008	1.008
	LTE Band 12	0.049	0.176	0.176
	LTE Band 17	0.061	0.139	0.139
WLAN	2.4GHz WLAN	0.434	0.117	0.117
	5GHz WLAN	0.172	0.275	0.275
2.4GHz Band	Bluetooth	0.124	0.062	0.062
Highest Simultaneous Transmission 1g SAR (W/kg)		Head	Body-worn	Hotspot
WWAN+WLAN 2.4GHz		1.157	1.125	1.125
WWAN+WLAN 5GHz		0.895	1.283	1.283
WWAN+Bluetooth		0.847	1.07	1.07

Note:

- 1、 The summary maximum simultaneous transmission SAR is combined at the same exposure position.
- 2、 Bluetooth is not required for SAR testing.



1.4. Photographs of the EUT

Please refer to the External Photos for the Photos of the EUT

1.5. Applied Reference Documents

Leading reference documents for testing:

No.	Identity	Document Title
1	47 CFR§2.1093	Radiofrequency Radiation Exposure Evaluation: Portable Devices
2	IEEE 1528-2013	IEEE Recommended Practice for Determining the Peak Spatial-Average Specific Absorption Rate (SAR) in the Human Head from Wireless Communications Devices: Measurement Techniques
3	KDB 447498 D01v06	General RF Exposure Guidance
4	KDB 248227 D01v02r02	SAR Measurement Procedures for 802.11 Transmitters
5	KDB 865664 D01v01r04	SAR Measurement 100 MHz to 6 GHz
6	KDB 865664 D02v01r02	RF Exposure Reporting
7	KDB 648474 D04v01r03	Handset SAR
8	KDB 941225 D01v03r01	3G SAR Measurement Procedures
9	KDB 941225 D05v02r05	SAR Evaluation Consideration for LTE Devices
10	KDB 941225 D06v02r01	SAR Evaluation Procedures For Portable Devices With Wireless Router Capabilities



2. Device Category and SAR Limits

Uncontrolled Environment

Uncontrolled Environments are defined as locations where there is the exposure of individuals who have no knowledge or control of their exposure. The general population/uncontrolled exposure limits are applicable to situations in which the general public may be exposed or in which persons who are exposed as a consequence of their employment may not be made fully aware of the potential for exposure or cannot exercise control over their exposure. Members of the general public would come under this category when exposure is not employment-related; for example, in the case of a wireless transmitter that exposes persons in its vicinity.

Controlled Environment

Controlled Environments are defined as locations where there is exposure that may be incurred by persons who are aware of the potential for exposure, (i.e. as a result of employment or occupation). In general, occupational/controlled exposure limits are applicable to situations in which persons are exposed as a consequence of their employment, who have been made fully aware of the potential for exposure and can exercise control over their exposure. The exposure category is also applicable when the exposure is of a transient nature due to incidental passage through a location where the exposure levels may be higher than the general population/uncontrolled limits, but the exposed person is fully aware of the potential for exposure and can exercise control over his or her exposure by leaving the area or by some other appropriate means.

Limits for Occupational/Controlled Exposure (W/kg)

Whole-Body	Partial-Body	Hands, Wrists, Feet and Ankles
0.4	8.0	20.0

Limits for General Population/Uncontrolled Exposure (W/kg)

Whole-Body	Partial-Body	Hands, Wrists, Feet and Ankles
0.08	1.6	4.0

Note: This device belongs to portable device category because its radiating structure is allowed to be used within 20 centimeters of the body of the user. Limit for General Population/Uncontrolled exposure should be applied for this device, it is 1.6 W/kg as averaged over any 1 gram of tissue.

3. Specific Absorption Rate (SAR)

3.1. Introduction

SAR is related to the rate at which energy is absorbed per unit mass in an object exposed to a radio field. The SAR distribution in a biological body is complicated and is usually carried out by experimental techniques or numerical modeling. The standard recommends limits for two tiers of groups, occupational/controlled and general population/uncontrolled, based on a person's awareness and ability to exercise control over his or her exposure. In general, occupational/controlled exposure limits are Middle than the limits for general population/uncontrolled.

3.2. SAR Definition

The SAR definition is the time derivative (rate) of the incremental energy (dW) absorbed by(dissipated in) an incremental mass (dm) contained in a volume element (dv) of a given density. (ρ). The equation description is as below:

$$SAR = \frac{d}{dt} \left(\frac{dW}{dm} \right) = \frac{d}{dt} \left(\frac{dW}{\rho dv} \right)$$

SAR is expressed in units of Watts per kilogram (W/kg)

SAR measurement can be either related to the temperature elevation in tissue by,

$$SAR = C \left(\frac{\delta T}{\delta t} \right)$$

Where C is the specific head capacity, δT is the temperature rise and δt the exposure duration, or related to the electrical field in the tissue by

$$SAR = \frac{\sigma |E|^2}{\rho}$$

Where ζ is the conductivity of the tissue, ρ is the mass density of the tissue and $|E|$ is the rmselectrical field strength.

However for evaluating SAR of low power transmitter, electrical field measurement is typically applied.

4. SAR Measurement Setup

4.1. The Measurement System

Como SAR is a system that is able to determine the SAR distribution inside a phantom of human being according to different standards. The Como SAR system consists of the Following items:

- Main computer to control all the system
- 6 axis robot
- Data acquisition system
- Miniature E-field probe
- Phone holder
- Head simulating tissue

The Following figure shows the system.



The EUT under test operating at the maximum power level is placed in the phone holder, under the phantom, which is filled with head simulating liquid. The E-Field probe measures the electric field inside the phantom. The OpenSAR software computes the results to give a SAR value in a 1g or 10g mass.

4.2. Probe

For the measurements the Specific Dosimetric E-Field Probe SN 37/08 EP80 with Following specifications is used

- Dynamic range: 0.01-100 W/kg

- Tip Diameter: 6.5 mm
- Distance between probe tip and sensor center: 2.5mm
- Distance between sensor center and the inner phantom surface: 4 mm
(repeatability better than +/- 1mm)
- Probe linearity: <0.25 dB
- Axial Isotropy: <0.25 dB
- Spherical Isotropy: <0.25 dB
- Calibration range: 835to 2500MHz for head & body simulating liquid.

Angle between probe axis (evaluation axis) and surface normal line: less than 30°

Probe calibration is realized, in compliance with CENELEC EN 62209 and IEEE 1528 std, with CALISAR, Antennassa proprietary calibration system. The calibration is performed with the EN 622091 annex technique using reference guide at the five frequencies.

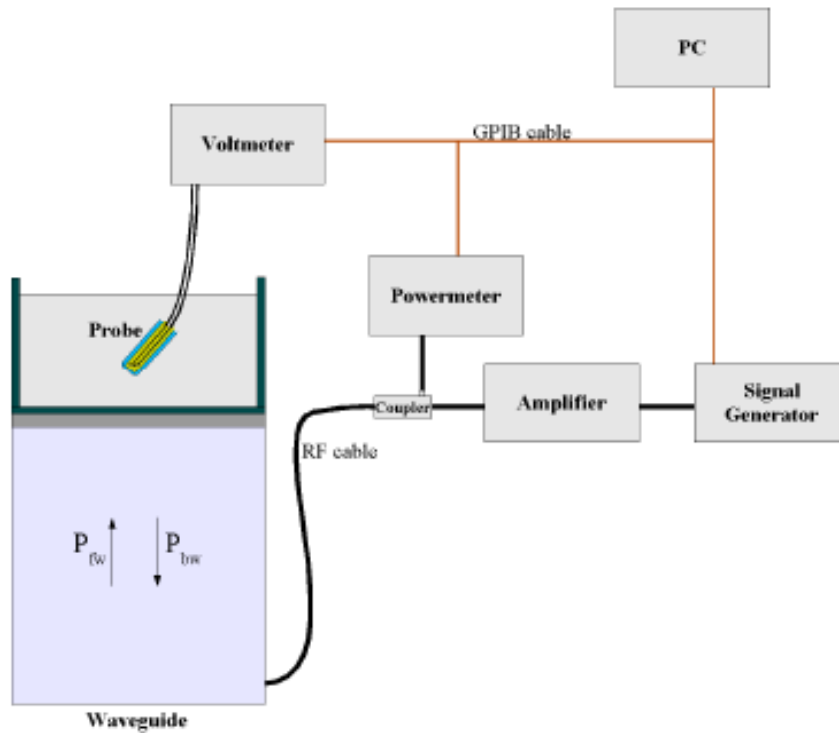

$$SAR = \frac{4(P_{fw} - P_{bw})}{ab\delta} \cos^2\left(\pi \frac{y}{a}\right) e^{-2z/\delta}$$

Where :

P_{fw} = Forward Power

P_{bw} = Backward Power

a and b = Waveguide dimensions



d = Skin depth

Keithley configuration:

Rate = Medium; Filter =ON; RDGS=10; FILTER TYPE =MOVING AVERAGE; RANGE AUTO

After each calibration, a SAR measurement is performed on a validation dipole and compared with aNPL calibrated probe, to verify it.

The calibration factors, CF(N), for the 3 sensors corresponding to dipole 1, dipole 2 and dipole 3 are:

$$CF(N)=SAR(N)/V_{lin}(N) \quad (N=1,2,3)$$

The linearised output voltage $V_{lin}(N)$ is obtained from the displayed output voltage $V(N)$ using

$$V_{lin}(N)=V(N)*(1+V(N)/DCP(N)) \quad (N=1,2,3)$$

Where DCP is the diode compression point in mV.

4.3. Probe Calibration Process

Dosimetric Assessment Procedure

Each E-Probe/Probe Amplifier combination has unique calibration parameters. SATIMO Probe calibration procedure is conducted to determine the proper amplifier settings to enter in the probe parameters. The amplifier settings are determined for a given frequency by subjecting the probe to a known E-field density (1 mW/cm²) using an with CALISAR, Antenna proprietary calibration system.

Free Space Assessment Procedure

The free space E-field from amplified probe outputs is determined in a test chamber. This calibration can be performed in a TEM cell if the frequency is below 1 GHz and in a waveguide or other methodologies above 1 GHz for free space. For the free space calibration, the probe is placed in the volumetric center of the cavity and at the proper orientation with the field. The probe is rotated 360 degrees until the three channels show the maximum reading. The power density readings equates to 1 mW/cm².

Temperature Assessment Procedure

E-field temperature correlation calibration is performed in a flat phantom filled with the appropriate simulating head tissue. The E-field in the medium correlates with the temperature rise in the dielectric medium. For temperature correlation calibration a RF transparent thermistor-based temperature probe is used in conjunction with the E-field probe.

Where:

δt = exposure time (30 seconds),

C = heat capacity of tissue (brain or muscle),

δT = temperature increase due to RF exposure.

SAR is proportional to $\Delta T/\Delta t$, the initial rate of tissue heating, before thermal diffusion takes place. The electric field in the simulated tissue can be used to estimate SAR by equating the thermally derived SAR to that with the E- field component.

Where:

ζ = simulated tissue conductivity,

ρ = Tissue density (1.25 g/cm³ for brain tissue)

4.4. Phantom

For the measurements the Specific Anthropomorphic Mannequin (SAM) defined by the IEEE SCC-34/SC2 group is used. The phantom is a polyurethane shell integrated in a wooden table. The thickness of the phantom amounts to 2mm +/- 0.2mm. It enables the dosimetric evaluation of left and right phone usage and includes an additional flat phantom part for the simplified performance check. The phantom set-up includes a cover, which prevents the evaporation of the liquid.

4.5. Device Holder

The positioning system allows obtaining cheek and tilting position with a very good accuracy. In compliance with CENELEC, the tilt angle uncertainty is Middle than 1°.

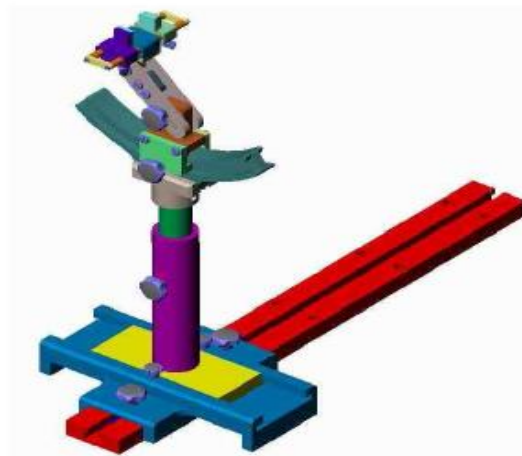

Device holder

System Material	Permittivity	Loss Tangent
Delrin	3.7	0.005

5. Measurement Procedures

The measurement procedures are as follows:

<Conducted power measurement>

- (a) For WWAN power measurement, use base station simulator to configure EUT WWAN transmission in conducted connection with RF cable, at maximum power in each supported wireless interface and frequency band.
- (b) Read the WWAN RF power level from the base station simulator.
- (c) For WLAN/BT power measurement, use engineering software to configure EUT WLAN/BT continuously transmission, at maximum RF power in each supported wireless interface and frequency band

Connect EUT RF port through RF cable to the power meter, and measure WLAN/BT output power

<SAR measurement>

- (a) Use base station simulator to configure EUT WWAN transmission in radiated connection, and engineering software to configure EUT WLAN/BT continuously transmission, at maximum RF power, in the highest power channel
- (b) Place the EUT in the positions as Appendix D demonstrates.
- (c) Set scan area, grid size and other setting on the DASY software.
- (d) Measure SAR results for the highest power channel on each testing position.
- (e) Find out the largest SAR result on these testing positions of each band
- (f) Measure SAR results for other channels in worst SAR testing position if the reported SAR of highest power channel is larger than 0.8 W/kg

According to the test standard, the recommended procedure for assessing the peak spatial-average SAR value consists of the following steps:

- (a) Power reference measurement
- (b) Area scan
- (c) Zoom scan
- (d) Power drift measurement

5.1. Spatial Peak SAR Evaluation

The procedure for spatial peak SAR evaluation has been implemented according to the test standard. It can be conducted for 1g and 10g, as well as for user-specific masses. The DASY software includes all numerical procedures necessary to evaluate the spatial peak SAR value. The base for the evaluation is a "cube" measurement. The measured volume must include the 1g and 10g cubes with the highest averaged SAR values. For that purpose, the center of the measured volume is aligned to the interpolated peak SAR value of a previously performed area scan.



The entire evaluation of the spatial peak values is performed within the post-processing engine. The system always gives the maximum values for the 1g and 10g cubes. The algorithm to find the cube with highest averaged SAR is divided into the following stages:

- (a) Extraction of the measured data (grid and values) from the Zoom Scan
- (b) Calculation of the SAR value at every measurement point based on all stored data (A/D values and measurement parameters)
- (c) Generation of a high-resolution mesh within the measured volume
- (d) Interpolation of all measured values from the measurement grid to the high-resolution grid
- (e) Extrapolation of the entire 3-D field distribution to the phantom surface over the distance from sensor to surface
- (f) Calculation of the averaged SAR within masses of 1g and 10g

5.2. Area Scan

The area scan is used as a fast scan in two dimensions to find the area of high field values, before doing a fine measurement around the hot spot. The sophisticated interpolation routines implemented in DASY software can find the maximum found in the scanned area, within a range of the global maximum. The range (in dB) is specified in the standards for compliance testing. For example, a 2 dB range is required in IEEE standard 1528 and IEC 62209 standards, whereby 3 dB is a requirement when compliance is assessed in accordance with the ARIB standard (Japan), if only one zoom scan follows the area scan, then only the absolute maximum will be taken as reference. For cases where multiple maximums are detected, the number of zoom scans has to be increased accordingly.

Area scan parameters extracted from FCC KDB 865664 D01v01r04 SAR measurement 100 MHz to 6 GHz.

	≤ 3 GHz	> 3 GHz
Maximum distance from closest measurement point (geometric center of probe sensors) to phantom surface	5 ± 1 mm	$\frac{1}{2} \cdot \delta \cdot \ln(2) \pm 0.5$ mm
Maximum probe angle from probe axis to phantom surface normal at the measurement location	30° ± 1°	20° ± 1°
Maximum area scan spatial resolution: Δx_{Area} , Δy_{Area}	≤ 2 GHz: ≤ 15 mm 2 – 3 GHz: ≤ 12 mm	3 – 4 GHz: ≤ 12 mm 4 – 6 GHz: ≤ 10 mm
	When the x or y dimension of the test device, in the measurement plane orientation, is smaller than the above, the measurement resolution must be ≤ the corresponding x or y dimension of the test device with at least one measurement point on the test device.	

5.3. Zoom Scan

Zoom scans are used to assess the peak spatial SAR values within a cubic averaging volume containing 1 gram and 10 gram of simulated tissue. The zoom scan measures points (refer to table below) within a cube whose base faces are centered on the maxima found in a preceding area scan job within the same procedure. When the measurement is done, the zoom scan evaluates the averaged SAR for 1 gram and 10 gram and displays these values next to the job's label.

Zoom scan parameters extracted from FCC KDB 865664 D01v01r04 SAR measurement 100 MHz to 6 GHz

		≤ 3 GHz	> 3 GHz
Maximum zoom scan spatial resolution: Δx_{Zoom} , Δy_{Zoom}		≤ 2 GHz: ≤ 8 mm $2 - 3$ GHz: ≤ 5 mm*	$3 - 4$ GHz: ≤ 5 mm* $4 - 6$ GHz: ≤ 4 mm*
Maximum zoom scan spatial resolution, normal to phantom surface	uniform grid: $\Delta z_{Zoom}(n)$	≤ 5 mm	$3 - 4$ GHz: ≤ 4 mm $4 - 5$ GHz: ≤ 3 mm $5 - 6$ GHz: ≤ 2 mm
	graded grid	$\Delta z_{Zoom}(1)$: between 1 st two points closest to phantom surface	≤ 4 mm
		$\Delta z_{Zoom}(n>1)$: between subsequent points	$\leq 1.5 \cdot \Delta z_{Zoom}(n-1)$
Minimum zoom scan volume	x, y, z	≥ 30 mm	$3 - 4$ GHz: ≥ 28 mm $4 - 5$ GHz: ≥ 25 mm $5 - 6$ GHz: ≥ 22 mm
Note: δ is the penetration depth of a plane-wave at normal incidence to the tissue medium; see draft standard IEEE P1528-2011 for details. * When zoom scan is required and the reported SAR from the area scan based 1-g SAR estimation procedures of KDB 447498 is ≤ 1.4 W/kg, ≤ 8 mm, ≤ 7 mm and ≤ 5 mm zoom scan resolution may be applied, respectively, for 2 GHz to 3 GHz, 3 GHz to 4 GHz and 4 GHz to 6 GHz.			

5.4. Power Drift Monitoring

All SAR testing is under the EUT install full charged battery and transmit maximum output power. In DASY measurement software, the power reference measurement and power drift measurement procedures are used for monitoring the power drift of EUT during SAR test. Both these procedures measure the field at a specified reference position before and after the SAR testing. The software will calculate the field difference in dB. If the power drifts more than 5%, the SAR will be retested.

6. Tissue Simulating Liquids

For SAR measurement of the field distribution inside the phantom, the phantom must be filled with Homogeneous tissue simulating liquid to a depth of at least 15cm. For head SAR testing, the liquid height from the ear reference point(ERP) of the phantom to the liquid top surface is larger than 15cm. For body SAR testing, the liquid height from the center of the flat phantom to the liquid top surface is larger than 15cm. The nominal dielectric values of the tissue simulating liquids in the phantom and the tolerance of 5% are listed in below table.



Fig 5.1 Photo of Liquid Height for Head SAR



Fig 5.2 Photo of Liquid Height for Body SAR

The following table gives the recipes for tissue simulating liquids

Frequency (MHz)	Water (%)	Sugar (%)	Cellulose (%)	Salt (%)	Preventol (%)	DGBE (%)	Conductivity (ζ)	Permittivity (εr)
Head								
750	41.1	57.0	0.2	1.4	0.2	0	0.89	41.9
835	40.3	57.9	0.2	1.4	0.2	0	0.90	41.5
1800, 1900, 2000	55.2	0	0	0.3	0	44.5	1.40	40.0
2450	55.0	0	0	0	0	45.0	1.80	39.2
2600	54.8	0	0	0.1	0	45.1	1.96	39.0
Body								
750	51.7	47.2	0	0.9	0.1	0	0.96	55.5
835	50.8	48.2	0	0.9	0.1	0	0.97	55.2
1800, 1900, 2000	70.2	0	0	0.4	0	29.4	1.52	53.3
2450	68.6	0	0	0	0	31.4	1.95	52.7
2600	68.1	0	0	0.1	0	31.8	2.16	52.5

Simulating Liquid for 5GHz, Manufactured by SPEAG

Ingredients	(% by weight)
Water	64~78%
Mineral oil	11~18%
Emulsifiers	9~15%
Additives and Salt	2~3%

Note: Please refer to the validation results for dielectric parameters of each frequency band.



The dielectric properties of the tissue simulating liquids were verified prior to the SAR evaluation using an Agilent 85033E Dielectric Probe Kit and an Agilent Network Analyzer.

Table : Dielectric Performance of Tissue Simulating Liquid

Frequency (MHz)	Tissue Type	Liquid Temp. (°C)	Conductivity (σ)	Conductivity Target (σ)	Delta (σ) (%)	Limit (%)	Date
750	HSL	21.2	0.890	0.89	0.00	±5	2018.04.08
835	HSL	21.2	0.892	0.90	-0.89	±5	2018.04.12
1800	HSL	22.6	1.365	1.40	-2.50	±5	2018.04.09
2000	HSL	22.4	1.414	1.40	1.00	±5	2018.04.09
2450	HSL	21.8	1.836	1.80	2.00	±5	2018.04.12
5200	HSL	22.1	4.665	4.66	0.11	±5	2018.04.13
5600	HSL	22.1	5.100	5.07	0.59	±5	2018.04.13
5800	HSL	22.1	5.310	5.27	0.76	±5	2018.04.13
750	MSL	21.2	1.000	0.96	4.17	±5	2018.04.05
835	MSL	21.2	0.972	0.97	0.21	±5	2018.04.11
1800	MSL	22.6	1.515	1.52	-0.33	±5	2018.04.05
2000	MSL	22.4	1.515	1.52	-0.33	±5	2018.04.10
2450	MSL	21.8	1.966	1.95	0.82	±5	2018.04.17
5200	MSL	22.1	5.543	5.30	4.58	±5	2018.04.16
5600	MSL	22.1	5.743	5.77	-0.47	±5	2018.04.16
5800	MSL	22.1	5.931	6.00	-1.15	±5	2018.04.16

Frequency (MHz)	Tissue Type	Liquid Temp. (°C)	Permittivity (ε _r)	Permittivity Target (ε _r)	Delta (ε _r) (%)	Limit (%)	Date
750	HSL	21.2	41.350	41.90	-1.31	±5	2018.04.08
835	HSL	21.2	41.182	41.50	-0.77	±5	2018.04.12
1800	HSL	22.6	40.095	40.00	0.24	±5	2018.04.09
2000	HSL	22.4	39.984	40.00	-0.04	±5	2018.04.09
2450	HSL	21.8	39.284	39.20	0.21	±5	2018.04.12
5200	HSL	22.1	36.123	36.00	0.34	±5	2018.04.13
5600	HSL	22.1	35.562	35.50	0.17	±5	2018.04.13
5800	HSL	22.1	35.335	35.30	0.10	±5	2018.04.13
750	MSL	21.2	53.520	55.50	-3.57	±5	2018.04.05
835	MSL	21.2	55.282	55.20	0.15	±5	2018.04.11
1800	MSL	22.6	53.295	53.30	-0.01	±5	2018.04.05



REPORT No. : SZ18030244S01

2000	MSL	22.4	53.285	53.30	-0.03	±5	2018.04.10
2450	MSL	21.8	52.884	52.70	0.35	±5	2018.04.17
5200	MSL	22.1	48.273	49.00	-1.48	±5	2018.04.16
5600	MSL	22.1	48.394	48.50	-0.22	±5	2018.04.16
5800	MSL	22.1	48.093	48.20	-0.22	±5	2018.04.16

7. Uncertainty Assessment

The Following table includes the uncertainty table of the IEEE 1528. The values are determined by Antenna.

7.1. Uncertainty Evaluation For EUT SAR Test

a	b	c	d	e= f(d,k)	f	g	h= c*f/e	i= c*g/e	k
Uncertainty Component	Sec.	Tol (+- %)	Prob . Dist.	Div.	Ci (1g)	Ci (10g)	1g Ui (+-%)	10g Ui (+-%)	Vi
Measurement System									
Probe calibration	E.2.1	5.83	N	1	1	1	5.83	5.83	∞
Axial Isotropy	E.2.2	3.5	R	$\sqrt{3}$	1	1	2.02	2.02	∞
Hemispherical Isotropy	E.2.2	5.9	R	$\sqrt{3}$	1	1	3.41	3.41	∞
Boundary effect	E.2.3	1.0	R	$\sqrt{3}$	1	1	0.58	0.58	∞
Linearity	E.2.4	4.7	R	$\sqrt{3}$	1	1	2.71	2.71	∞
System detection limits	E.2.5	1.0	R	$\sqrt{3}$	1	1	0.58	0.58	∞
Modulation Response	E.2.4	4.1	R	$\sqrt{3}$	1	1	2.4	2.4	∞
Readout Electronics	E.2.6	0.5	N	1	1	1	0.5	0.5	∞
Reponse Time	E.2.7	3.0	R	$\sqrt{3}$	1	1	3.0	3.0	∞
Integration Time	E.2.8	1.4	R	$\sqrt{3}$	1	1	0.81	0.81	∞
RF ambient Conditions	E.6.1	3.0	R	$\sqrt{3}$	1	1	1.73	1.73	∞
Probe positioner Mechanical Tolerance	E.6.2	1.4	R	$\sqrt{3}$	1	1	0.81	0.81	∞
Probe positioning with respect to Phantom Shell	E.6.3	1.4	R	$\sqrt{3}$	1	1	0.81	0.81	∞
Extrapolation, interpolation and integration Algorithms for Max. SAR Evaluation	E.5.2	2.3	R	$\sqrt{3}$	1	1	1.33	1.33	∞
Test sample Related									
Test sample positioning	E.4.2. 1	2.6	N	1	1	1	2.6	2.6	N-1
Device Holder Uncertainty	E.4.1.	3.0	N	1	1	1	3.0	3.0	N-1



	1								
Output power Power drift - SAR drift measurement	6.6.2	5.0	R	$\sqrt{3}$	1	1	2.89	2.89	∞
Phantom and Tissue Parameters									
Phantom Uncertainty (Shape and thickness tolerances)	E.3.1	4.0	R	$\sqrt{3}$	1	1	2.31	2.31	∞
Liquid conductivity - deviation from target value	E.3.2	2.0	R	$\sqrt{3}$	0.6 4	0.43	1.69	1.13	∞
Liquid conductivity - measurement uncertainty	E.3.3	2.5	N	1	0.6 4	0.43	3.20	2.15	M
Liquid permittivity - deviation from target value	E.3.2	2.5	R	$\sqrt{3}$	0.6	0.49	1.28	1.04	∞
Liquid permittivity - measurement uncertainty	E.3.3	5.0	N	1	0.6	0.49	6.00	4.90	M
Liquid conductivity-temperature uncertainty	E.3.4		R	$\sqrt{3}$	0.7 8	0.41			∞
Liquid permittivity-temperature uncertainty	E.3.4		R	$\sqrt{3}$	0.2 3	0.26			∞
Combined Standard Uncertainty			RSS				11.55	12.0 7	
Expanded Uncertainty (95% Confidence interval)			K=2				\pm 23.20	\pm 24.17	

7.2. Uncertainty For System Performance Check

a	b	c	d	e= f(d,k)	f	g	h= c*f/e	i= c*g/ e	k
Uncertainty Component	Sec.	Tol (+-%)	Prob Dist.	Div.	Ci (1g)	Ci (10g)	1g Ui (+-%)	10g Ui (+-%)	Vi
Measurement System									
Probe calibration	E.2.1	4.76	N	1	1	1	4.76	4.7	∞
Axial Isotropy	E.2.2	2.5	R	$\sqrt{3}$	0.7	0.7	1.01	1.0	∞
Hemispherical Isotropy	E.2.2	4.0	R	$\sqrt{3}$	0.7	0.7	1.62	1.6	∞



Boundary effect	E.2.3	1.0	R	$\sqrt{3}$	1	1	0.58	0.5	∞
Linearity	E.2.4	5.0	R	$\sqrt{3}$	1	1	2.89	2.8	∞
System detection limits	E.2.5	1.0	R	$\sqrt{3}$	1	1	0.58	0.5	∞
Readout Electronics	E.2.6	0.02	N	1	1	1	0.02	0.0	∞
Reponse Time	E.2.7	3.0	R	$\sqrt{3}$	1	1	1.73	1.7	∞
Integration Time	E.2.8	2.0	R	$\sqrt{3}$	1	1	1.15	1.1	∞
RF ambient Conditions	E.6.1	3.0	R	$\sqrt{3}$	1	1	1.73	1.7	∞
Probe positioner Mechanical Tolerance	E.6.2	2.0	R	$\sqrt{3}$	1	1	1.15	1.1 5	∞
Probe positioning with respect to Phantom Shell	E.6.3	0.05	R	$\sqrt{3}$	1	1	0.03	0.0 3	∞
Extrapolation, interpolation and integration Algorithms for Max. SAR Evaluation	E.5.2	5.0	R	$\sqrt{3}$	1	1	2.89	2.8 9	∞
Dipole									
Dipole axis to liquid Distance	8,E.4. 2	1.00	N	$\sqrt{3}$	1	1	0.58	0.5 8	∞
Input power and SAR drift measurement	8,6.6. 2	4.04	R	$\sqrt{3}$	1	1	2.33	2.3 3	∞
Phantom and Tissue Parameters									
Phantom Uncertainty (Shape and thickness tolerances)	E.3.1	0.05	R	$\sqrt{3}$	1	1	0.03	0.0 3	∞
Liquid conductivity - deviation from target value	E.3.2	4.57	R	$\sqrt{3}$	0.64	0.43	1.69	1.1 3	∞
Liquid conductivity - measurement uncertainty	E.3.3	5.00	N	$\sqrt{3}$	0.64	0.43	1.85	1.2 4	M
Liquid permittivity - deviation from target value	E.3.2	3.69	R	$\sqrt{3}$	0.6	0.49	1.28	1.0 4	∞
Liquid permittivity - measurement uncertainty	E.3.3	10.0 0	N	$\sqrt{3}$	0.6	0.49	3.46	2.8 3	M
Combined Standard Uncertainty			RSS				8.83	8.3 7	
Expanded Uncertainty (95% Confidence interval)			K=2				17.66	16. 73	

8. SAR Measurement Evaluation

8.1. System Setup

In the simplified setup for system evaluation, the DUT is replaced by a calibrated dipole and the power source is replaced by a continuous wave which comes from a signal generator. The calibrated dipole must be placed beneath the flat phantom section of the SAM twin phantom with the correct distance holder. The distance holder should touch the phantom surface with a light pressure at the reference marking and be oriented parallel to the long side of the phantom. The system check verifies that the system operates within its specifications. It is performed daily or before every SAR measurement. The system check uses normal SAR measurements in the flat section of the phantom with a matched dipole at a specified distance. The system verification setup is shown as below

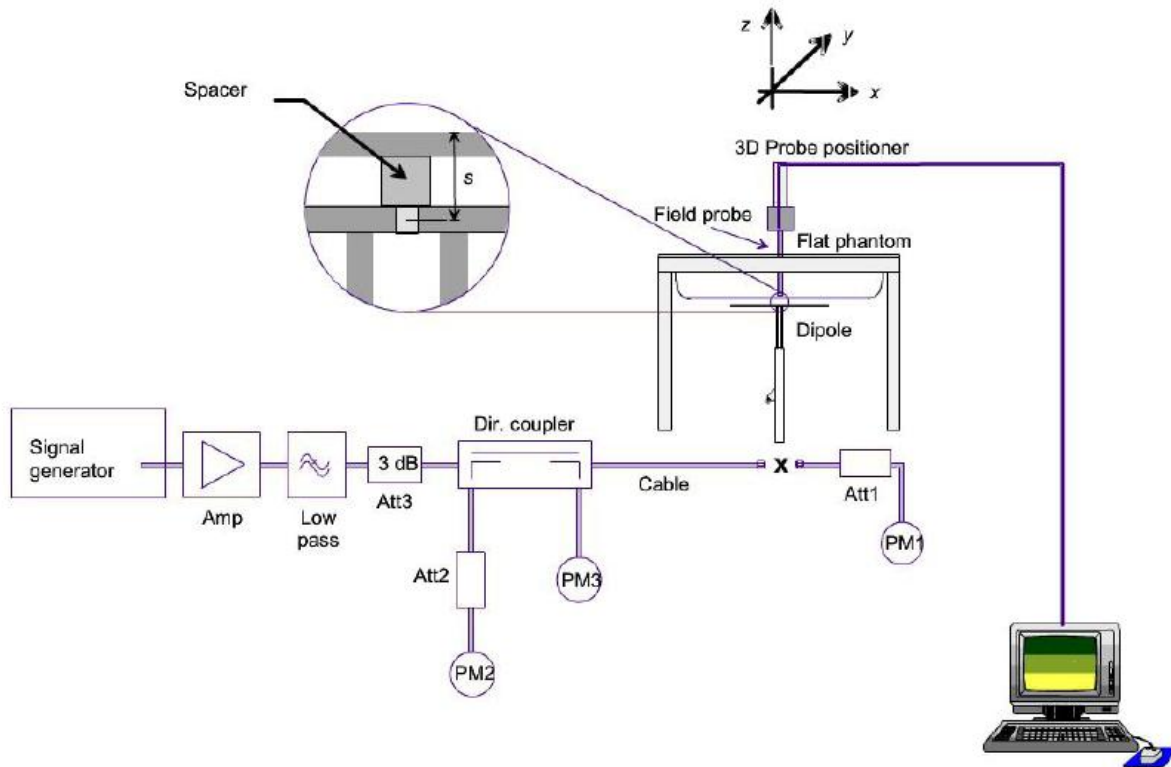

The validation dipole is placed beneath the flat phantom with the specific spacer in place. The distance spacer is touched to the phantom surface with a light pressure at the reference marking and is oriented parallel to the long side of the phantom. The power meter PM1 measures the forward power at the location of the system check dipole connector. The signal generator is adjusted for the desired forward power (250mW is used for 700MHz to 3GHz, 100mW is used for 3.5GHz to 6 GHz) at the dipole connector and the power meter PM2 is read at that level. After connecting the cable to the dipole, the signal generator is readjusted for the same reading at the power meter.

8.2. Validation Results

After system check testing, the SAR result will be normalized to 1W forward input power and compared with the reference SAR value derived from validation dipole certificate report. The deviation of system check should be within 10 %.

<1g SAR>

Date	Frequency (MHz)	Tissue Type	Input Power (mW)	Measured 1g SAR (W/kg)	Targeted 1g SAR (W/kg)	Normalized 1g SAR (W/kg)	Deviation (%)
2018.04.08	750	HSL	100	0.78	8.41	7.84	-6.78
2018.04.12	835	HSL	100	0.97	9.61	9.68	0.73
2018.04.09	1800	HSL	100	3.70	37.05	36.98	-0.19
2018.04.09	2000	HSL	100	4.26	42.70	42.56	-0.33
2018.04.12	2450	HSL	100	5.33	53.34	53.26	-0.15
2018.04.13	5200	HSL	100	16.40	164.05	163.99	-0.04
2018.04.13	5600	HSL	100	17.14	177.81	171.44	-3.58
2018.04.13	5800	HSL	100	17.71	185.02	177.11	-4.28
2018.04.05	750	MSL	100	0.91	8.69	9.054	4.19
2018.04.11	835	MSL	100	0.99	9.88	9.87	-0.10
2018.04.05	1800	MSL	100	3.75	37.78	37.53	-0.66
2018.04.10	2000	MSL	100	4.12	41.43	41.2	-0.56
2018.04.17	2450	MSL	100	5.08	50.93	50.81	-0.24
2018.04.16	5200	MSL	100	16.28	163.36	162.84	-0.32
2018.04.16	5600	MSL	100	17.20	172.11	171.96	-0.09
2018.04.16	5800	MSL	100	17.70	177.10	176.95	-0.08

<10g SAR>

Date	Frequency (MHz)	Tissue Type	Input Power (mW)	Measured 10g SAR (W/kg)	Targeted 10g SAR (W/kg)	Normalized 10g SAR (W/kg)	Deviation (%)
2018.04.08	750	HSL	100	0.54	5.52	5.37	-2.72
2018.04.12	835	HSL	100	0.62	6.17	6.22	0.81
2018.04.09	1800	HSL	100	2.05	19.85	20.48	3.17
2018.04.09	2000	HSL	100	1.99	21.39	19.93	-6.83
2018.04.12	2450	HSL	100	2.38	24.22	23.77	-1.86
2018.04.13	5200	HSL	100	5.65	57.03	56.51	-0.91
2018.04.13	5600	HSL	100	6.05	60.90	60.54	-0.59
2018.04.13	5800	HSL	100	5.99	62.43	59.94	-3.99



2018.04.05	750	MSL	100	0.61	5.78	6.097	5.48
2018.04.11	835	MSL	100	0.63	6.48	6.29	-2.93
2018.04.05	1800	MSL	100	2.04	20.15	20.38	1.14
2018.04.10	2000	MSL	100	2.09	20.86	20.93	0.34
2018.04.17	2450	MSL	100	2.38	23.26	23.77	2.19
2018.04.16	5200	MSL	100	5.62	57.09	56.24	-1.49
2018.04.16	5600	MSL	100	5.91	58.61	59.07	0.78
2018.04.16	5800	MSL	100	5.98	59.95	59.83	-0.20

Note: System checks the specific test data please see Annex C

9. RF Exposure Positions

9.1. Information on the testing

The mobile phone antenna and battery are those specified by the manufacturer. The battery is fully charged before each measurement. The output power and frequency are controlled using a base station simulator. The mobile phone is set to transmit at its highest output peak power level. The mobile phone is test in the “cheek” and “tilted” positions on the left and right sides of the phantom. The mobile phone is placed with the vertical centre line of the body of the mobile phone and the horizontal line crossing the centre of the earpiece in a plane parallel to the sagittal plane of the phantom.

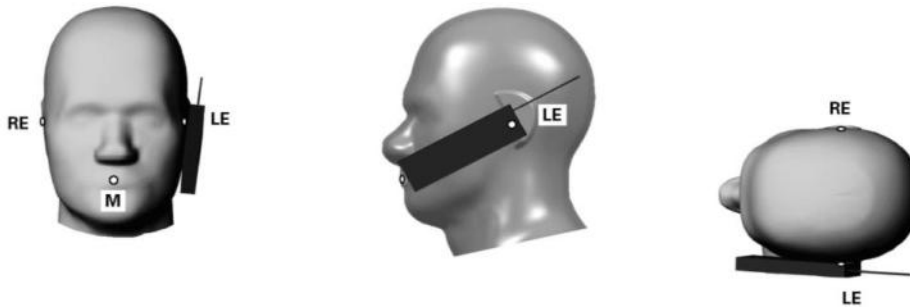

Fig 9.1 Illustration for Cheek Position

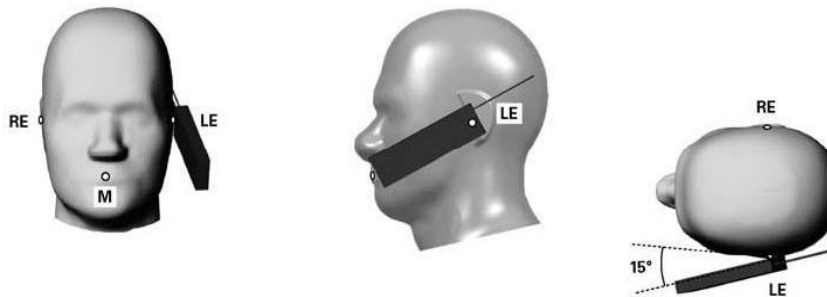

Fig 9.2 Illustration for Tilted Position

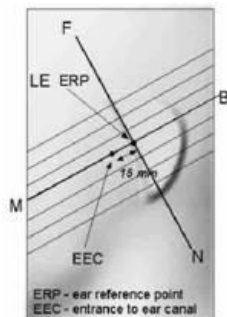

Fig 9.3 Close-up side view of phantom showing the ear region.

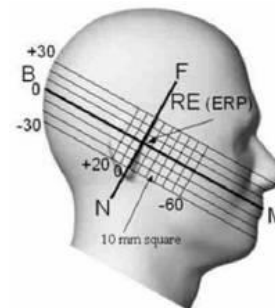

Fig 9.4 Side view of the phantom showing relevant markings and seven cross-sectional plane locations

Description of the “cheek” position:

The mobile phone is well placed in the reference plane and the earpiece is in contact with the ear. Then the mobile phone is moved until any point on the front side get in contact with the cheek of the phantom or until contact with the ear is lost.

Description of the “tilted” position:

The mobile phone is well placed in the “cheek” position as described above. Then the mobile phone is moved outward away from the mouth by an angle of 15 degrees or until contact with the ear lost.

Remark: Please refer to Appendix B for the test setup photos.

9.2. Body-worn Configurations

The body-worn configurations shall be tested with the supplied accessories (belt-clips, holsters, etc.) attached to the device in normal use configuration.

For body-worn and other configurations a flat phantom shall be used which is comprised of material with electrical properties similar to the corresponding tissues.

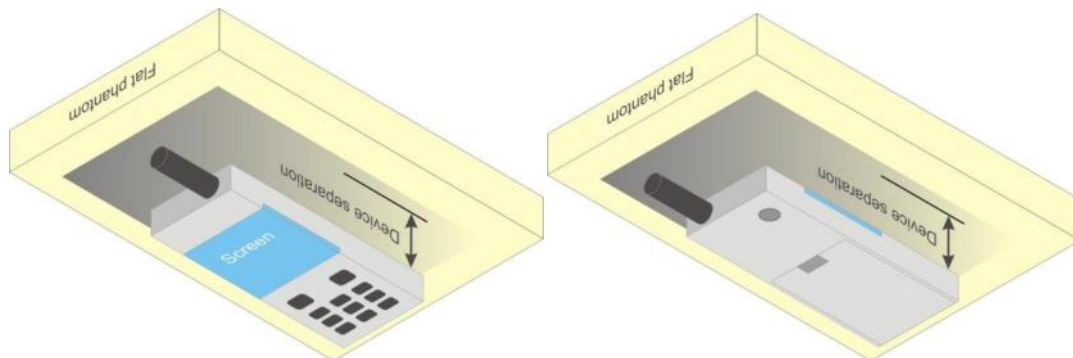

Fig 9.5 Illustration for Body-Worn Position

9.3. Hotspot Mode Exposure Position Conditions

For handsets that support hotspot mode operations, with wireless router capabilities and various web browsing functions, the relevant hand and body exposure conditions are tested according to the hotspot SAR procedures in KDB 941225. A test separation distance of 10 mm is required between the phantom and all surfaces and edges with a transmitting antenna located within 25 mm from that surface or edge. When the form factor of a handset is smaller than 9 cm x 5 cm, a test separation distance of 5 mm (instead of 10 mm) is

required for testing hotspot mode. When the separation distance required for body-worn accessory testing is larger than or equal to that tested for hotspot mode, in the same wireless mode and for the same surface of the phone, the hotspot mode SAR data may be used to support body-worn accessory SAR compliance for that particular configuration (surface).

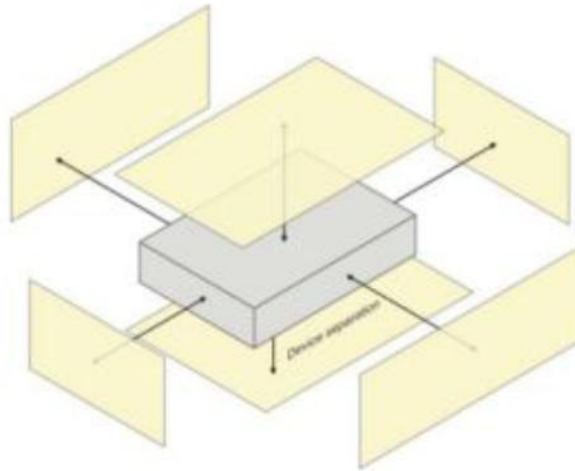

Fig 9.6 Illustration for Hotspot Position

9.4. Measurement procedure

The Following steps are used for each test position

1. Establish a call with the maximum output power with a base station simulator. The connection between the mobile and the base station simulator is established via air interface.
2. Measurement of the local E-field value at a fixed location. This value serves as a reference value for calculating a possible power drift.
3. Measurement of the SAR distribution with a grid of 8 to 16mm * 8 to 16 mm and a constant distance to the inner surface of the phantom. Since the sensors cannot directly measure at the inner phantom surface, the values between the sensors and the inner phantom surface are extrapolated. With these values the area of the maximum SAR is calculated by an interpolation scheme.
4. Around this point, a cube of 30 * 30 * 30 mm or 32 * 32 * 32 mm is assessed by measuring 5 or 8 * 5 or 8*4 or 5 mm. With these data, the peak spatial-average SAR value can be calculated.

9.5. Description of interpolation/extrapolation scheme

The local SAR inside the phantom is measured using small dipole sensing elements inside a probe



body. The probe tip must not be in contact with the phantom surface in order to minimize measurements errors, but the highest local SAR will occur at the surface of the phantom.

An extrapolation is using to determinate this highest local SAR values. The extrapolation is based on a fourth-order least-square polynomial fit of measured data. The local SAR value is then extrapolated from the liquid surface with a 1mm step.

The measurements have to be performed over a limited time (due to the duration of the battery) so the step of measurement is high. It could vary between 5 and 8 mm. To obtain an accurate assessment of the maximum SAR averaged over 10 grams and 1 gram requires a very fine resolution in the three dimensional scanned data array.

10. Hot-spot Mode Evaluation Procedure

Antenna position:

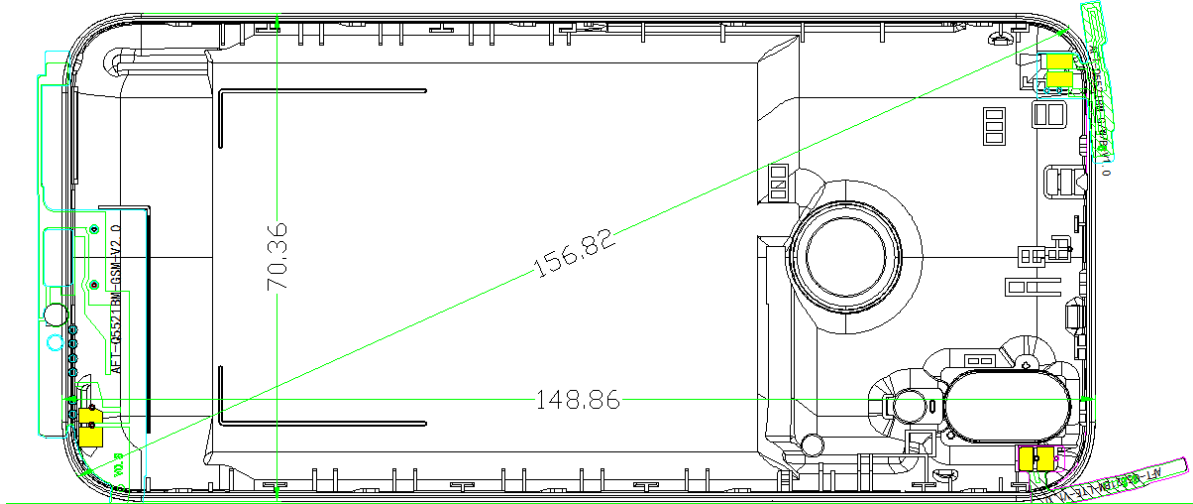

Distance of the antenna to the EUT surface/edge						
Antenna	Back	Front	Top	Left	Right	Bottom
LTE/WCDMA/GSM	≤25mm	≤25mm	>25mm	≤25mm	≤25mm	≤25mm
WLAN&BT	≤25mm	≤25mm	≤25mm	≤25mm	≤25mm	>25mm

Evaluation of Hotspot side for SAR						
Antenna	Back	Front	Top	Left	Right	Bottom
LTE/WCDMA/GSM	Yes	Yes	No	Yes	Yes	Yes
WLAN&BT	Yes	Yes	Yes	Yes	Yes	No

Note:

The SAR evaluation procedures for Portable Devices with Wireless Router function is according to KDB 941225 D06 Hotspot SAR v02r01.

1. Head/Body-worn/Hotspot mode SAR assessments are required.
2. Referring to KDB 941225 D06, when the overall device length and width are $\geq 9\text{cm} \times 5\text{cm}$, the test distance is 10 mm. SAR must be measured for all sides and surfaces with a transmitting antenna located within 25mm from that surface or edge.
3. For Main antenna, SAR measurements at Top side and Right Side are not required since the distance between DUT and flat phantom $> 25\text{mm}$.
4. For WLAN&BT antenna, SAR measurements Top side and Right side are not required since the distance between DUT and flat phantom $> 25\text{mm}$.
5. For the secondary antenna, it supports RX only, SAR is not required.

11. SAR Evaluation Procedures for LTE

1. QPSK with 1 RB allocation

Start with the largest channel bandwidth and measure SAR for QPSK with 1 RB allocation, using the RB offset and *required test channel* combination with the highest maximum output power for RB offsets at the upper edge, middle and lower edge of each *required test channel*. When the *reported SAR* is ≤ 0.8 W/kg, testing of the remaining RB offset configurations and *required test channels* is not required for 1 RB allocation; otherwise, SAR is required for the remaining *required test channels* and only for the RB offset configuration with the highest output power for that channel. When the *reported SAR* of a *required test channel* is > 1.45 W/kg, SAR is required for all three RB offset configurations for that *required test channel*.

2. QPSK with 50% RB allocation

The procedures required for 1 RB allocation in 1. are applied to measure the SAR for QPSK with 50% RB allocation.

3. QPSK with 100% RB allocation

For QPSK with 100% RB allocation, SAR is not required when the highest maximum output power for 100 % RB allocation is less than the highest maximum output power in 50% and 1 RB allocations and the highest *reported SAR* for 1 RB and 50% RB allocation in 1. and 2. are ≤ 0.8 W/kg. Otherwise, SAR is measured for the highest output power channel and if the *reported SAR* is > 1.45 W/kg, the remaining *required test channels* must also be tested.

Higher order modulations

For each modulation besides QPSK; e.g., 16-QAM, 64-QAM, apply the QPSK procedures in sections 1. and 2. and 3. to determine the QAM configurations that may need SAR measurement. For each configuration identified as required for testing, SAR is required only when the highest maximum output power or the configuration in the higher order modulation is $> \frac{1}{2}$ dB higher than the same configuration in QPSK or when the *reported SAR* for the QPSK configuration is > 1.45 W/kg.

4. Other channel bandwidth standalone SAR test requirements

For the other channel bandwidths used by the device in a frequency band, apply all the procedures required for the largest channel bandwidth in section 5.2 to determine the channels and RB configurations SAR that need SAR testing and only measure SAR when the highest maximum output power of a configuration requiring testing in the smaller channel bandwidth is $> \frac{1}{2}$ dB higher than the equivalent channel configurations in the largest channel bandwidth configuration or the *reported SAR* of a configuration for the largest channel bandwidth is > 1.45 W/kg.

The equivalent channel configuration for the RB allocation, RB offset and modulation etc. Is determined for the smaller channel bandwidth according to the same number of RB allocated in



REPORT No. : SZ18030244S01

The largest channel bandwidth. For example, 50 RB in 10 MHz channel bandwidth does not apply to 5 MHz channel bandwidth; therefore, this cannot be tested in the smaller channel bandwidth. However, 50% RB allocation in 10 MHz channel bandwidths equivalent to 100% RB allocation in 5 MHz channel bandwidth; therefore, these are the equivalent configurations to be compared to determine the specific channel and configuration in the smaller channel bandwidth that need SAR testing.”

12. Measurement of Conducted output power

1. GSM Conducted Average output power

GSM850	Burst Average Power (dBm)			Tune-up Limit (dBm)	Frame-Average Power (dBm)			Tune-up Limit (dBm)
	128	190	251		128	190	251	
TX Channel	128	190	251	32.50	824.2	836.6	848.8	23.50
Frequency (MHz)	824.2	836.6	848.8		23.11	23.12	22.98	
GSM 1 Tx slot	32.11	32.12	31.98	32.50	23.11	23.12	22.98	23.50
GPRS 1 Tx slot	31.86	31.86	31.80	32.50	22.86	22.86	22.80	23.50
GPRS 2 Tx slots	31.05	31.02	30.97	31.50	25.05	25.02	24.97	25.50
GPRS 3 Tx slots	29.26	29.26	29.25	30.00	25.00	25.00	24.99	25.74
GPRS 4 Tx slots	28.15	28.20	28.20	29.00	25.15	25.20	25.20	26.00
EDGE 1 Tx slot	29.64	29.50	29.32	30.00	20.64	20.50	20.32	21.00
EDGE 2 Tx slots	28.95	28.83	28.57	29.00	22.95	22.83	22.57	23.00
EDGE 3 Tx slots	28.12	28.11	28.02	28.50	23.86	23.85	23.76	24.24
EDGE 4 Tx slots	27.65	27.60	27.57	28.00	24.65	24.60	24.57	25.00

GSM1900	Burst Average Power (dBm)			Tune-up Limit (dBm)	Frame-Average Power (dBm)			Tune-up Limit (dBm)
	512	661	810		512	661	810	
TX Channel	512	661	810	28.00	1850.2	1880	1909.8	19.00
Frequency (MHz)	1850.2	1880	1909.8		18.20	17.93	17.85	
GSM 1 Tx slot	27.20	26.93	26.85	28.00	18.20	17.93	17.85	19.00
GPRS 1 Tx slot	27.45	27.50	27.31	28.00	18.45	18.50	18.31	19.00
GPRS 2 Tx slots	26.63	26.60	26.54	27.00	20.63	20.60	20.54	21.00
GPRS 3 Tx slots	24.97	24.94	24.97	25.50	20.71	20.68	20.71	21.24
GPRS 4 Tx slots	23.95	23.91	23.87	24.50	20.95	20.91	20.87	21.50
EDGE 1 Tx slot	26.98	26.51	25.80	27.00	17.98	17.51	16.80	18.00
EDGE 2 Tx slots	26.14	25.61	25.00	26.50	20.14	19.61	19.00	20.50
EDGE 3 Tx slots	25.08	25.05	25.11	25.50	20.82	20.79	20.85	21.24
EDGE 4 Tx slots	23.86	23.81	23.83	24.00	20.86	20.81	20.83	21.00

Timeslot consignations:

No. of Slots	Slot 1	Slot 2	Slot 3	Slot 4
Slot Consignation	1Up4Down	2Up3Down	3Up2Down	4Up1Down
Duty Cycle	1:83	1:4.15	1:2.77	1:208
Correct Factor	-9.03dB	-6.02dB	-4.26dB	-3.01dB



2. WCDMA Conducted Average output power

Band	WCDMA II			Tune-up Limit (dBm)	WCDMA IV			Tune-up Limit (dBm)
	TX Channel	9262	9400		9538	1312	1413	
Rx Channel	9662	9800	9938		1537	1638	1738	
Frequency (MHz)	1852.4	1880	1907.6		1712.4	1732.6	1752.6	
AMR 12.2Kbps	22.70	22.67	22.60	23.00	23.25	23.15	23.24	24.00
RMC 12.2Kbps	22.71	22.68	22.61	23.00	23.26	23.17	23.25	24.00
HSDPA Subtest-1	21.99	21.92	21.89	22.00	22.39	22.32	22.42	23.00
HSDPA Subtest-2	21.95	21.93	21.90	22.00	22.37	22.35	22.38	23.00
HSDPA Subtest-3	21.48	21.45	21.41	22.00	21.93	21.92	21.94	22.50
HSDPA Subtest-4	21.43	21.43	21.39	22.00	21.84	21.82	21.88	22.50
HSUPA Subtest-1	19.83	19.88	19.83	20.00	20.49	20.40	20.41	22.00
HSUPA Subtest-2	19.89	19.86	19.84	20.00	20.46	20.35	20.49	21.00
HSUPA Subtest-3	20.92	20.86	20.85	21.00	21.43	21.35	21.42	22.00
HSUPA Subtest-4	19.46	19.41	19.43	20.00	20.05	19.89	19.99	20.50
HSUPA Subtest-5	20.83	20.82	20.81	22.00	21.45	21.33	21.38	22.00
HSPA+ (16QAM) Subtest-1	20.87	20.85	20.84	21.50	21.32	21.17	21.22	22.00

Band	WCDMA V			Tune-up Limit (dBm)
	TX Channel	4132	4182	
Rx Channel	4357	4407	4458	
Frequency (MHz)	826.4	836.4	846.6	
AMR 12.2Kbps	23.10	23.11	23.10	24.00
RMC 12.2Kbps	23.12	23.17	23.12	24.00
HSDPA Subtest-1	22.19	22.19	22.25	23.00
HSDPA Subtest-2	22.21	22.25	22.23	23.00
HSDPA Subtest-3	21.70	21.71	21.76	22.50
HSDPA Subtest-4	21.69	21.71	21.74	22.50
HSUPA Subtest-1	20.22	20.24	20.21	22.00
HSUPA Subtest-2	20.27	20.26	20.23	21.00
HSUPA Subtest-3	21.28	21.35	21.29	22.00
HSUPA Subtest-4	19.79	19.85	19.81	20.00
HSUPA Subtest-5	21.20	21.26	21.23	22.00
HSPA+ (16QAM) Subtest-1	21.26	21.28	21.31	22.00



3. LTE Conducted Average output power

LTE Band 2

BW [MHz]	Modulation	RB Size	RB Offset	Power Low Ch. / Freq.	Power Middle Ch. / Freq.	Power High Ch. / Freq.	Tune-up limit (dBm)
Channel				18700	18900	19100	
Frequency (MHz)				1860	1880	1900	
20	QPSK	1	0	23.47	23.72	23.55	24
20	QPSK	1	49	23.23	23.40	23.36	
20	QPSK	1	99	23.41	23.46	23.48	
20	QPSK	50	0	22.76	22.79	22.60	23
20	QPSK	50	24	22.48	22.59	22.40	
20	QPSK	50	50	22.43	22.41	22.30	
20	QPSK	100	0	22.38	22.41	22.20	
20	16QAM	1	0				23
Channel				18675	18900	19125	Tune-up limit (dBm)
Frequency (MHz)				1857.5	1880	1902.5	
15	QPSK	1	0	23.36	23.60	23.54	24
15	QPSK	1	37	23.28	23.30	23.26	
15	QPSK	1	74	23.40	23.46	23.30	
15	QPSK	36	0	22.56	22.79	22.60	23
15	QPSK	36	20	22.38	22.48	22.34	
15	QPSK	36	39	22.43	22.41	22.34	
15	QPSK	75	0	22.30	22.44	22.28	
Channel				18650	18900	19150	Tune-up limit (dBm)
Frequency (MHz)				1855	1880	1905	
10	QPSK	1	0	23.09	23.32	23.08	24
10	QPSK	1	25	23.10	23.30	23.12	
10	QPSK	1	49	23.24	23.44	23.41	
10	QPSK	25	0	22.39	22.38	22.27	23
10	QPSK	25	12	22.13	22.41	22.38	
10	QPSK	25	25	22.25	22.26	22.24	
10	QPSK	50	0	22.30	22.21	22.34	
Channel				18625	18900	19175	Tune-up



Frequency (MHz)				1852.5	1880	1907.5	limit (dBm)
5	QPSK	1	0	22.99	23.19	23.20	24
5	QPSK	1	12	23.24	23.24	23.15	
5	QPSK	1	24	22.99	23.13	23.04	
5	QPSK	12	0	22.34	22.39	22.36	23
5	QPSK	12	7	22.36	22.51	22.41	
5	QPSK	12	13	22.42	22.48	22.43	
5	QPSK	25	0	22.30	22.18	22.24	
Channel				18615	18900	19185	Tune-up
Frequency (MHz)				1851.5	1880	1908.5	limit (dBm)
3	QPSK	1	0	23.70	23.67	23.20	24
3	QPSK	1	8	23.44	23.20	23.35	
3	QPSK	1	14	22.99	23.13	23.41	
3	QPSK	8	0	22.37	22.38	22.38	23
3	QPSK	8	4	22.28	22.41	22.50	
3	QPSK	8	7	22.42	22.48	22.53	
3	QPSK	15	0	22.23	22.24	22.18	
Channel				18607	18900	19193	Tune-up
Frequency (MHz)				1850.7	1880	1909.3	limit (dBm)
1.4	QPSK	1	0	22.78	23.03	22.96	24
1.4	QPSK	1	3	22.96	22.89	22.98	
1.4	QPSK	1	5	22.94	22.97	22.90	
1.4	QPSK	3	0	23.01	23.33	23.12	
1.4	QPSK	3	1	23.14	23.10	23.01	
1.4	QPSK	3	3	23.00	23.02	23.05	
1.4	QPSK	6	0	22.10	22.05	22.09	23



LTE Band 4

BW [MHz]	Modulation	RB Size	RB Offset	Power Low Ch. / Freq.	Power Middle Ch. / Freq.	Power High Ch. / Freq.	Tune-up limit (dBm)
Channel				20050	20175	20300	
Frequency (MHz)				1720	1732.5	1745	
20	QPSK	1	0	24.06	24.04	23.91	24.5
20	QPSK	1	49	23.98	23.86	23.84	
20	QPSK	1	99	23.91	23.90	23.93	
20	QPSK	50	0	23.46	23.22	23.18	23.5
20	QPSK	50	24	22.90	22.86	22.85	
20	QPSK	50	50	22.84	22.86	22.79	
20	QPSK	100	0	22.79	22.76	22.78	
20	16QAM	1	0				23.5
Channel				20025	20175	20325	Tune-up limit (dBm)
Frequency (MHz)				1717.5	1732.5	1747.5	
15	QPSK	1	0	23.88	23.87	23.89	24.5
15	QPSK	1	37	23.90	23.78	23.76	
15	QPSK	1	74	23.70	23.81	23.86	
15	QPSK	36	0	22.77	22.78	22.86	23.5
15	QPSK	36	20	22.76	22.78	22.90	
15	QPSK	36	39	22.91	22.85	22.70	
15	QPSK	75	0	22.87	22.70	22.71	
Channel				20000	20175	20350	Tune-up limit (dBm)
Frequency (MHz)				1715	1732.5	1750	
10	QPSK	1	0	23.81	23.90	23.91	24.5
10	QPSK	1	25	23.90	23.88	23.89	
10	QPSK	1	49	23.88	23.86	23.95	
10	QPSK	25	0	22.85	22.92	22.90	23.5
10	QPSK	25	12	22.87	22.80	22.83	
10	QPSK	25	25	22.81	22.83	22.80	
10	QPSK	50	0	22.76	22.77	22.71	
Channel				19975	20175	20375	Tune-up limit (dBm)
Frequency (MHz)				1712.5	1732.5	1752.5	



5	QPSK	1	0	23.70	23.70	23.46	24.5
5	QPSK	1	12	23.69	23.72	23.71	
5	QPSK	1	24	23.70	23.68	23.65	
5	QPSK	12	0	22.75	22.87	22.67	23.5
5	QPSK	12	7	22.78	22.71	22.68	
5	QPSK	12	13	22.76	22.90	22.91	
5	QPSK	25	0	22.86	22.83	22.80	
Channel				19965	20175	20385	Tune-up limit (dBm)
Frequency (MHz)				1711.5	1732.5	1753.5	
3	QPSK	1	0	23.71	23.95	23.59	24.5
3	QPSK	1	8	23.65	23.62	23.70	
3	QPSK	1	14	23.71	23.69	23.68	
3	QPSK	8	0	22.75	22.81	22.68	23.5
3	QPSK	8	4	22.70	22.71	22.67	
3	QPSK	8	7	22.86	22.91	22.90	
3	QPSK	15	0	22.81	22.80	22.82	
Channel				19957	20175	20393	Tune-up limit (dBm)
Frequency (MHz)				1710.7	1732.5	1754.3	
1.4	QPSK	1	0	23.36	23.51	23.33	24.5
1.4	QPSK	1	3	23.10	23.02	23.04	
1.4	QPSK	1	5	23.11	23.12	23.15	
1.4	QPSK	3	0	22.91	22.85	22.79	
1.4	QPSK	3	1	23.01	23.02	23.05	
1.4	QPSK	3	3	23.10	23.12	23.04	
1.4	QPSK	6	0	22.87	22.86	22.78	23.5



LTE Band 12

BW [MHz]	Modulation	RB Size	RB Offset	Power Low Ch. / Freq.	Power Middle Ch. / Freq.	Power High Ch. / Freq.	Tune-up limit (dBm)
Channel				23060	23095	23130	
Frequency (MHz)				704	707.5	711	
10	QPSK	1	0	22.65	22.81	22.54	23.5
10	QPSK	1	25	22.70	22.61	22.48	
10	QPSK	1	49	22.86	22.87	22.81	
10	QPSK	25	0	22.15	22.23	22.15	22.5
10	QPSK	25	12	22.05	22.06	22.10	
10	QPSK	25	25	22.11	22.13	22.12	
10	QPSK	50	0	22.00	22.01	22.03	
Channel				23035	23095	23155	Tune-up limit (dBm)
Frequency (MHz)				701.5	707.5	713.5	
5	QPSK	1	0	22.74	22.59	22.31	23.5
5	QPSK	1	12	22.54	22.48	22.38	
5	QPSK	1	24	22.47	22.55	22.35	
5	QPSK	12	0	22.41	22.40	22.34	22.5
5	QPSK	12	7	22.12	22.05	22.10	
5	QPSK	12	13	22.13	22.14	22.05	
5	QPSK	25	0	22.04	22.13	22.16	
Channel				23025	23095	23165	Tune-up limit (dBm)
Frequency (MHz)				700.5	707.5	714.5	
3	QPSK	1	0	22.35	22.59	22.31	23.5
3	QPSK	1	8	22.51	22.38	22.32	
3	QPSK	1	14	22.47	22.55	22.35	
3	QPSK	8	0	22.41	22.40	22.34	22.5
3	QPSK	8	4	22.10	22.05	22.10	
3	QPSK	8	7	22.13	22.12	22.15	
3	QPSK	15	0	22.02	22.10	22.06	
Channel				23017	23095	23173	Tune-up limit (dBm)
Frequency (MHz)				699.7	707.5	715.3	
1.4	QPSK	1	0	22.51	22.40	22.17	23.5
1.4	QPSK	1	3	22.67	22.60	22.51	



1.4	QPSK	1	5	22.54	22.56	22.61	
1.4	QPSK	3	0	22.66	22.52	22.60	
1.4	QPSK	3	1	22.54	22.71	22.56	
1.4	QPSK	3	3	22.70	22.71	22.54	
1.4	QPSK	6	0	22.15	22.16	22.17	
							22.5

LTE Band 17

BW [MHz]	Modulation	RB Size	RB Offset	Power Low Ch. / Freq.	Power Middle Ch. / Freq.	Power High Ch. / Freq.	Tune-up limit (dBm)
Channel				23780	23790	23800	
Frequency (MHz)				709	710	711	
10	QPSK	1	0	22.59	22.75	22.61	23.5
10	QPSK	1	25	22.75	22.73	22.68	
10	QPSK	1	49	22.74	22.71	22.85	
10	QPSK	25	0	21.74	21.85	21.91	22.5
10	QPSK	25	12	21.80	21.86	21.87	
10	QPSK	25	25	21.84	21.80	21.77	
10	QPSK	50	0	21.90	21.82	21.87	
10	16QAM	1	0				22.5
Channel				23755	23790	23825	Tune-up limit (dBm)
Frequency (MHz)				706.5	710	713.5	
5	QPSK	1	0	22.47	22.69	22.50	23.5
5	QPSK	1	12	22.61	22.48	22.51	
5	QPSK	1	24	22.41	22.32	22.36	
5	QPSK	12	0	21.78	21.65	21.63	22.5
5	QPSK	12	7	21.40	21.28	21.34	
5	QPSK	12	13	21.33	21.46	21.58	
5	QPSK	25	0	21.41	21.36	21.33	

4. 2.4GHz Wi-Fi Average output power

2.4GHz WLAN	Mode	Channel	Frequency (MHz)	Average power (dBm)	Tune-Up Limit	Duty cycle %
	802.11b 1Mbps		CH 1	2412	14.83	15.50
CH 6			2437	15.39	15.50	100
CH 11			2462	14.10	15.00	100
802.11g 6Mbps		CH 1	2412	10.07	11.00	100
		CH 6	2437	12.60	13.00	100
		CH 11	2462	11.20	12.00	100
802.11n-HT20 MCS0		CH 1	2412	10.12	12.00	100
		CH 6	2437	12.76	13.00	100
		CH 11	2462	11.03	12.00	100
802.11n-HT40 MCS0		CH 3	2422	11.77	12.00	100
		CH 6	2437	11.39	12.00	100
		CH 9	2452	11.02	12.00	100

5. 5GHz Wi-Fi Average output power

5.2GHz WLAN	Mode	Channel	Frequency (MHz)	Average power (dBm)	Tune-Up Limit	Duty cycle %
	802.11a 6Mbps		CH 36	5180	11.59	12.00
CH 44			5220	11.29	12.00	100
CH 48			5240	11.69	12.00	100
802.11n-HT20 MCS0		CH 36	5180	10.73	11.00	100
		CH 44	5220	10.61	11.00	100
		CH 48	5240	10.71	11.00	100
802.11n-HT40 MCS0		CH 38	5190	10.78	11.00	100
		CH 46	5230	10.88	11.00	100



5.3GHz WLAN	Mode	Channel	Frequency (MHz)	Average power (dBm)	Tune-Up Limit	Duty cycle %
	802.11a 6Mbps	CH 52	5260	11.07	12.00	100
CH 60		5300	11.68	12.00	100	
CH 64		5320	11.45	12.00	100	
802.11n-HT20 MCS0	CH 52	5260	10.96	11.00	100	
	CH 60	5300	10.41	11.00	100	
	CH 64	5320	10.58	11.00	100	
802.11n-HT40 MCS0	CH 54	5270	10.74	11.00	100	
	CH 62	5310	10.75	11.00	100	

5.5GHz WLAN	Mode	Channel	Frequency (MHz)	Average power (dBm)	Tune-Up Limit	Duty cycle %
	802.11a 6Mbps	CH 100	5500	12.09	12.5	100
CH 120		5600	13.00	13.50	100	
CH 140		5700	11.59	12.00	100	
802.11n-HT20 MCS0	CH 100	5500	11.23	12.00	100	
	CH 120	5600	11.52	12.00	100	
	CH 140	5700	11.84	12.00	100	
802.11n-HT40 MCS0	CH 102	5510	11.46	12.00	100	
	CH 126	5630	12.08	12.50	100	
	CH 142	5710	12.06	12.50	100	

5.8GHz WLAN	Mode	Channel	Frequency (MHz)	Average power (dBm)	Tune-Up Limit	Duty cycle %
	802.11a MCS0	CH 149	5745	11.82	12.00	100
CH 157		5785	11.60	12.00	100	
CH 165		5825	11.94	12.50	100	
802.11n-HT20 MCS0	CH 149	5745	11.54	12.00	100	
	CH 157	5785	11.66	12.00	100	
	CH 165	5825	11.82	12.00	100	
802.11n-HT40 MCS0	CH 151	5755	11.89	12.00	100	
	CH 159	5795	12.02	12.50	100	



6. BT average output power

Mode	Channel	Frequency (MHz)	Average power (dBm)		
			1Mbps	2Mbps	3Mbps
BR / EDR	CH 00	2402	3.90	2.69	2.84
	CH 39	2441	3.46	2.55	2.53
	CH 78	2480	3.67	2.70	2.96
Tune-up Limit (dBm)			4.5	3.5	3.5

Mode	Channel	Frequency (MHz)	Peak power (dBm)
			GFSK
LE	CH 00	2402	-3.47
	CH 19	2440	-3.09
	CH 39	2480	-3.33
Tune-up Limit (dBm)			-2.0

13. Test Results List

13.1. Test Guidance:

<GSM>

1. Per KDB 447498 D01v06, the maximum output power channel is used for SAR testing and for further SAR test reduction.
2. Per KDB 941225 D01v03r01, for SAR test reduction for GSM / GPRS / EDGE modes is determined by the source-based time-averaged output power including tune-up tolerance. The mode with highest specified time-averaged output power should be tested for SAR compliance in the applicable exposure conditions. For modes with the same specified maximum output power and tolerance, the higher number time-slot configuration should be tested. Therefore, the GPRS (4Tx slots) for GSM850/GSM1900 is considered as the primary mode.
3. Other configurations of GSM / GPRS / EDGE are considered as secondary modes.

<WCDMA>

1. The 3G SAR test reduction procedure is applied, when the maximum output power and tune-up tolerance specified for production units in a secondary mode is $\leq \frac{1}{4}$ dB higher than the primary mode, SAR measurement is not required for the secondary mode.
2. The following tests were conducted according to the test requirements outlines in 3GPP TS 34.121 specification.
3. The procedures in KDB 941225 D01v03r01 are applied for 3GPP Rel. 6 HSPA to configure the device in the required sub-test mode(s) to determine SAR test exclusion.
4. For HSPA+ devices supporting 16 QAM in the uplink, power measurements procedure is according to the configurations in Table C.11.1.4 of 3GPP TS 34.121-1.
5. Per KDB 941225 D01v03r01, RMC 12.2kbps setting is used to evaluate SAR. The maximum output power and tune-up tolerance specified for production units in HSDPA / HSUPA / DC-HSDPA / HSPA+ is $\leq \frac{1}{4}$ dB higher than RMC 12.2Kbps or when the highest reported SAR of the RMC12.2Kbps is scaled by the ratio of specified maximum output power and tune-up tolerance of HSDPA / HSUPA / DC-HSDPA / HSPA+ to RMC12.2Kbps and the adjusted SAR is ≤ 1.2 W/kg, SAR measurement is not required for HSDPA / HSUPA / DC-HSDPA / HSPA+, and according to the following RF output power, the output power results of the secondary modes (HSDPA / HSUPA / DC-HSDPA / HSPA+) are less than $\frac{1}{4}$ dB higher than the primary modes; therefore, SAR measurement is not required for HSDPA / HSUPA / DC-HSDPA / HSPA+.

**<LTE>**

1. Per KDB 447498 D01v06, the reported SAR is the measured SAR value adjusted for maximum tune-up tolerance.
 - a. Tune-up scaling Factor = tune-up limit power (mW) / EUT RF power (mW), where tune-up limit is the maximum rated power among all production units.
 - b. For SAR testing of WLAN signal with non-100% duty cycle, the measured SAR is scaled-up by the duty cycle scaling factor which is equal to "1/(duty cycle)"
 - c. For WWAN: Reported SAR(W/kg)= Measured SAR(W/kg)*Tune-up Scaling Factor
 - d. For WLAN/Bluetooth: Reported SAR(W/kg)= Measured SAR(W/kg)* Duty Cycle scaling factor * Tune-up scaling factor
 - e. For TDD LTE SAR measurement, the duty cycle 1:1.59 (62.9 %) was used perform testing and considering the theoretical duty cycle of 63.3% for extended cyclic prefix in the uplink, and the theoretical duty cycle of 62.9% for normal cyclic prefix in uplink, a scaling factor of extended cyclic prefix $63.3\%/62.9\% = 1.006$ is applied to scale-up the measured SAR result. The Reported TDD LTE SAR = measured SAR (W/kg)* Tune-up Scaling Factor* scaling factor for extended cyclic prefix.
2. Per KDB 447498 D01v06, for each exposure position, testing of other required channels within the operating mode of a frequency band is not required when the reported 1-g or 10-g SAR for the mid-band or highest output power channel is: ≤ 0.8 W/kg or 2.0 W/kg, for 1-g or 10-g respectively, when the transmission band is ≤ 100 MHz ≤ 0.6 W/kg or 1.5 W/kg, for 1-g or 10-g respectively, when the transmission band is between 100 MHz and 200 MHz ≤ 0.4 W/kg or 1.0 W/kg, for 1-g or 10-g respectively, when the transmission band is ≥ 200 MHz
3. Per KDB 865664 D01v01r04, for each frequency band, repeated SAR measurement is required only when the measured SAR is ≥ 0.8 W/kg.
4. Per KDB 648474 D04v01r03, when the reported SAR for a body-worn accessory measured without a headset connected to the handset is ≤ 1.2 W/kg, SAR testing with a headset connected to the handset is not required.

<WLAN>

1. SAR is measured for 2.4 GHz 802.11b DSSS using either the fixed test position or, when applicable, the initial test position procedure. SAR test reduction is determined according to the following:
 - 1) When the reported SAR of the highest measured maximum output power channel for the exposure configuration is ≤ 0.8 W/kg, no further SAR testing is required for 802.11b DSSS in that exposure configuration.
 - 2) When the reported SAR is > 0.8 W/kg, SAR is required for that position using the next highest measured output power channel. When any reported SAR is > 1.2 W/kg, SAR is required for the third channel; i.e., all channels require testing.
2. 2.4 GHz 802.11 g/n OFDM are additionally evaluated for SAR if the highest reported SAR for



3. 802.11b, adjusted by the ratio of the OFDM to DSSS specified maximum output power, is > 1.2 W/kg. When SAR is required for OFDM modes in 2.4 GHz band, the Initial Test Configuration Procedures should be followed.
4. For held-to-ear and hotspot operations, the initial test position procedures were applied. The test position with the highest extrapolated peak SAR will be used as the initial test position. When reported SAR for the initial test position is ≤ 0.4 W/kg, no additional testing for the remaining test positions was required. Otherwise, SAR is evaluated at the subsequent highest peak SAR positions until the reported SAR result is ≤ 0.8 W/kg or all test positions are measured. Justification for test configurations for WLAN per KDB Publication 248227 D02DR02-41929 for 2.4 GHz WI-FI single transmission chain operations, the highest measured maximum output power channel for DSSS was selected for SAR measurement. SAR for OFDM modes (2.4 GHz 802.11g/n) was not required due to the maximum allowed powers and the highest reported DSSS SAR.

13.2. SAR Test Result

Summary of Measurement Results for Head (test distance is 0mm)

<GSM850 & GSM1900>

Plot No.	Band	Mode	Test Position	Gap (mm)	Ch.	Freq. (MHz)	Tune-up Scaling Factor	Measured 1g SAR (W/kg)	Reported 1g SAR (W/kg)
	GSM850	GPRS(4 TX slots)	Right Cheek	0mm	190	836.6	1.072	0.256	0.274
	GSM850	GPRS(4 TX slots)	Right Tilt	0mm	190	836.6	1.072	0.211	0.226
1#	GSM850	GPRS(4 TX slots)	Left Cheek	0mm	190	836.6	1.072	0.310	0.332
	GSM850	GPRS(4 TX slots)	Left Tilt	0mm	190	836.6	1.072	0.185	0.198
2#	GSM1900	GPRS(4 TX slots)	Right Cheek	0mm	512	1850.2	1.012	0.228	0.231
	GSM1900	GPRS(4 TX slots)	Right Tilt	0mm	512	1850.2	1.012	0.077	0.078
	GSM1900	GPRS(4 TX slots)	Left Cheek	0mm	512	1850.2	1.012	0.206	0.208
	GSM1900	GPRS(4 TX slots)	Left Tilt	0mm	512	1850.2	1.012	0.051	0.052



<WCDMA Band II/IV/V>

Plot No.	Band	Mode	Test Position	Gap (mm)	Ch.	Freq. (MHz)	Tune-up Scaling Factor	Measured 1g SAR (W/kg)	Reported 1g SAR (W/kg)
3#	WCDMA Band II	RMC 12.2Kbps	Right Cheek	0mm	9262	1852.4	1.069	0.284	0.304
	WCDMA Band II	RMC 12.2Kbps	Right Tilt	0mm	9262	1852.4	1.069	0.122	0.130
	WCDMA Band II	RMC 12.2Kbps	Left Cheek	0mm	9262	1852.4	1.069	0.270	0.289
	WCDMA Band II	RMC 12.2Kbps	Left Tilt	0mm	9262	1852.4	1.069	0.052	0.056
4#	WCDMA Band IV	RMC 12.2Kbps	Right Cheek	0mm	1312	1712.4	1.057	0.375	0.396
	WCDMA Band IV	RMC 12.2Kbps	Right Tilt	0mm	1312	1712.4	1.057	0.173	0.183
	WCDMA Band IV	RMC 12.2Kbps	Left Cheek	0mm	1312	1712.4	1.057	0.332	0.351
	WCDMA Band IV	RMC 12.2Kbps	Left Tilt	0mm	1312	1712.4	1.057	0.129	0.136
	WCDMA Band V	RMC 12.2Kbps	Right Cheek	0mm	4182	836.4	1.079	0.176	0.190
	WCDMA Band V	RMC 12.2Kbps	Right Tilt	0mm	4182	836.4	1.079	0.112	0.121
5#	WCDMA Band V	RMC 12.2Kbps	Left Cheek	0mm	4132	826.4	1.079	0.229	0.247
	WCDMA Band V	RMC 12.2Kbps	Left Tilt	0mm	4182	836.4	1.079	0.140	0.151

<LTE Band 2/4/12/17>

Plot No.	Band	BW (MHz)	RB Size	RB offset	Test Position	Ch.	Freq. (MHz)	Tune-up Scaling Factor	Measured 1g SAR (W/kg)	Reported 1g SAR (W/kg)
6#	LTE Band 2	20Mhz	1	0	Right Cheek	18900	1880	1.067	0.614	0.655
	LTE Band 2	20Mhz	1	0	Right Tilt	18900	1880	1.067	0.145	0.155
	LTE Band 2	20Mhz	1	0	Left Cheek	18900	1880	1.067	0.497	0.530
	LTE Band 2	20Mhz	1	0	Left Tilt	18900	1880	1.067	0.092	0.098
	LTE Band 2	20Mhz	50	0	Right Cheek	18900	1880	1.050	0.304	0.319
	LTE Band 2	20Mhz	50	0	Right Tilt	18900	1880	1.050	0.103	0.108
	LTE Band 2	20Mhz	50	0	Left Cheek	18900	1880	1.050	0.278	0.292
	LTE Band 2	20Mhz	50	0	Left Tilt	18900	1880	1.050	0.056	0.059
	LTE Band 4	20Mhz	1	0	Right Cheek	20050	1720	1.107	0.431	0.477
	LTE Band 4	20Mhz	1	0	Right Tilt	20050	1720	1.107	0.177	0.196
7#	LTE Band 4	20Mhz	1	0	Left Cheek	20050	1720	1.107	0.653	0.723
	LTE Band 4	20Mhz	1	0	Left Tilt	20050	1720	1.107	0.142	0.157
	LTE Band 4	20Mhz	50	0	Right Cheek	20050	1720	1.009	0.323	0.326
	LTE Band 4	20Mhz	50	0	Right Tilt	20050	1720	1.009	0.138	0.139



	LTE Band 4	20Mhz	50	0	Left Cheek	20050	1720	1.009	0.371	0.374
	LTE Band 4	20Mhz	50	0	Left Tilt	20050	1720	1.009	0.101	0.102
8#	LTE Band 12	10Mhz	1	49	Right Cheek	23095	707.5	1.030	0.048	0.049
	LTE Band 12	10Mhz	1	49	Right Tilt	23095	707.5	1.030	0.036	0.037
	LTE Band 12	10Mhz	1	49	Left Cheek	23095	707.5	1.030	0.042	0.043
	LTE Band 12	10Mhz	1	49	Left Tilt	23095	707.5	1.030	0.020	0.021
	LTE Band 12	10Mhz	25	0	Right Cheek	23095	707.5	1.064	0.038	0.040
	LTE Band 12	10Mhz	25	0	Right Tilt	23095	707.5	1.064	0.025	0.027
	LTE Band 12	10Mhz	25	0	Left Cheek	23095	707.5	1.064	0.039	0.042
	LTE Band 12	10Mhz	25	0	Left Tilt	23095	707.5	1.064	0.019	0.020
9#	LTE Band 17	10Mhz	1	49	Right Cheek	23800	711	1.035	0.059	0.061
	LTE Band 17	10Mhz	1	49	Right Tilt	23800	711	1.035	0.037	0.038
	LTE Band 17	10Mhz	1	49	Left Cheek	23800	711	1.035	0.026	0.027
	LTE Band 17	10Mhz	1	49	Left Tilt	23800	711	1.035	0.030	0.031
	LTE Band 17	10Mhz	25	0	Right Cheek	23800	711	1.146	0.030	0.034
	LTE Band 17	10Mhz	25	0	Right Tilt	23800	711	1.146	0.021	0.024
	LTE Band 17	10Mhz	25	0	Left Cheek	23800	711	1.146	0.041	0.047
	LTE Band 17	10Mhz	25	0	Left Tilt	23800	711	1.146	0.017	0.019

<WLAN2.4GHZ &WLAN 5GHZ >

Plot No.	Band	Mode	Test Position	Ch.	Freq. (MHz)	Tune-up Scaling Factor	Measured 1g SAR (W/kg)	Reported 1g SAR (W/kg)
10#	WLAN2.4GHz	802.11b	Right Cheek	6	2437	1.026	0.423	0.434
	WLAN2.4GHz	802.11b	Right Tilt	6	2437	1.026	0.311	0.319
	WLAN2.4GHz	802.11b	Left Cheek	6	2437	1.026	0.169	0.173
	WLAN2.4GHz	802.11b	Left Tilt	6	2437	1.026	0.310	0.318
	WLAN5GHz	802.11a	Right Cheek	48	5240	1.074	0.075	0.081
11#	WLAN5GHz	802.11a	Right Tilt	48	5240	1.074	0.088	0.095
	WLAN5GHz	802.11a	Left Cheek	48	5240	1.074	0.060	0.064
	WLAN5GHz	802.11a	Left Tilt	48	5240	1.074	0.030	0.032
	WLAN5GHz	802.11a	Right Cheek	60	5300	1.076	0.084	0.090
	WLAN5GHz	802.11a	Right Tilt	60	5300	1.076	0.047	0.051
12#	WLAN5GHz	802.11a	Left Cheek	60	5300	1.076	0.103	0.111
	WLAN5GHz	802.11a	Left Tilt	60	5300	1.076	0.100	0.108



	WLAN5GHz	802.11a	Right Cheek	120	5600	1.122	0.142	0.159
	WLAN5GHz	802.11a	Right Tilt	120	5600	1.122	0.120	0.135
13#	WLAN5GHz	802.11a	Left Cheek	120	5600	1.122	0.153	0.172
	WLAN5GHz	802.11a	Left Tilt	120	5600	1.122	0.037	0.042
14#	WLAN5GHz	802.11n-HT40 MCS0	Right Cheek	159	5795	1.117	0.126	0.141
	WLAN5GHz	802.11n-HT40 MCS0	Right Tilt	159	5795	1.117	0.111	0.124
	WLAN5GHz	802.11n-HT40 MCS0	Left Cheek	159	5795	1.117	0.102	0.114
	WLAN5GHz	802.11n-HT40 MCS0	Left Tilt	159	5795	1.117	0.026	0.029

Summary of Measurement Results for Body

< GSM850&GSM1900>

Plot No.	Band	Mode	Test Position	Gap (mm)	Ch.	Freq. (MHz)	Tune-up Scaling Factor	Measured 1g SAR (W/kg)	Reported 1g SAR (W/kg)
	GSM850	GSM Voice	Front Side	10mm	190	836.6	1.091	0.279	0.305
	GSM850	GSM Voice	Back Side	10mm	190	836.6	1.091	0.347	0.379
	GSM850	GPRS(4 TX slots)	Front Side	10mm	190	836.6	1.072	0.501	0.537
15#	GSM850	GPRS(4 TX slots)	Back Side	10mm	190	836.6	1.072	0.740	0.793
	GSM850	GPRS(4 TX slots)	Right Side	10mm	190	836.6	1.072	0.242	0.259
	GSM850	GPRS(4 TX slots)	Left Side	10mm	190	836.6	1.072	0.489	0.524
	GSM850	GPRS(4 TX slots)	Bottom Side	10mm	190	836.6	1.072	0.137	0.147
	GSM1900	GSM Voice	Front Side	10mm	512	1850.2	1.202	0.302	0.363
	GSM1900	GSM Voice	Back Side	10mm	512	1850.2	1.202	0.413	0.497
	GSM1900	GPRS(4 TX slots)	Front Side	10mm	512	1850.2	1.012	0.526	0.532
16#	GSM1900	GPRS(4 TX slots)	Back Side	10mm	512	1850.2	1.012	0.587	0.594
	GSM1900	GPRS(4 TX slots)	Right Side	10mm	512	1850.2	1.012	0.219	0.222
	GSM1900	GPRS(4 TX slots)	Left Side	10mm	512	1850.2	1.012	0.179	0.181
	GSM1900	GPRS(4 TX slots)	Bottom Side	10mm	512	1850.2	1.012	0.533	0.539



<WCDMA Band II/IV/V>

Plot No.	Band	Mode	Test Position	Gap (mm)	Ch.	Freq. (MHz)	Tune-up Scaling Factor	Measured 1g SAR (W/kg)	Reported 1g SAR (W/kg)
	WCDMA Band II	RMC 12.2Kbps	Front Side	10mm	9262	1852.4	1.069	0.514	0.549
17#	WCDMA Band II	RMC 12.2Kbps	Back Side	10mm	9262	1852.4	1.069	0.586	0.626
	WCDMA Band II	RMC 12.2Kbps	Right Side	10mm	9262	1852.4	1.069	0.223	0.238
	WCDMA Band II	RMC 12.2Kbps	Left Side	10mm	9262	1852.4	1.069	0.192	0.205
	WCDMA Band II	RMC 12.2Kbps	Bottom Side	10mm	9262	1852.4	1.069	0.572	0.611
	WCDMA Band IV	RMC 12.2Kbps	Front Side	10mm	1312	1712.4	1.057	0.717	0.758
18#	WCDMA Band IV	RMC 12.2Kbps	Back Side	10mm	1312	1712.4	1.057	0.742	0.784
	WCDMA Band IV	RMC 12.2Kbps	Right Side	10mm	1312	1712.4	1.057	0.308	0.325
	WCDMA Band IV	RMC 12.2Kbps	Left Side	10mm	1312	1712.4	1.057	0.220	0.232
	WCDMA Band IV	RMC 12.2Kbps	Bottom Side	10mm	1312	1712.4	1.057	0.538	0.569
	WCDMA Band V	RMC 12.2Kbps	Front Side	10mm	4182	836.4	1.079	0.186	0.201
19#	WCDMA Band V	RMC 12.2Kbps	Back Side	10mm	4182	836.4	1.079	0.409	0.441
	WCDMA Band V	RMC 12.2Kbps	Right Side	10mm	4182	836.4	1.079	0.135	0.146
	WCDMA Band V	RMC 12.2Kbps	Left Side	10mm	4182	836.4	1.079	0.229	0.247
	WCDMA Band V	RMC 12.2Kbps	Bottom Side	10mm	4182	836.4	1.079	0.068	0.073

<LTE Band 2/4/12/17>

Plot No.	Band	BW (MHz)	RB Size	RB offset	Test Position	Gap (mm)	Ch.	Freq. (MHz)	Tune-up Scaling Factor	Measured 1g SAR (W/kg)	Reported 1g SAR (W/kg)
	LTE Band 2	20Mhz	1	0	Front Side	10mm	18900	1880	1.067	0.422	0.450
	LTE Band 2	20Mhz	1	0	Back Side	10mm	18900	1880	1.067	0.577	0.615
	LTE Band 2	20Mhz	1	0	Right Side	10mm	18900	1880	1.067	0.278	0.297
	LTE Band 2	20Mhz	1	0	Left Side	10mm	18900	1880	1.067	0.180	0.192
20#	LTE Band 2	20Mhz	1	0	Bottom Side	10mm	18900	1880	1.067	0.625	0.667
	LTE Band 2	20Mhz	50	0	Front Side	10mm	18900	1880	1.050	0.350	0.367
	LTE Band 2	20Mhz	50	0	Back Side	10mm	18900	1880	1.050	0.419	0.440
	LTE Band 2	20Mhz	50	0	Right Side	10mm	18900	1880	1.050	0.200	0.210
	LTE Band 2	20Mhz	50	0	Left Side	10mm	18900	1880	1.050	0.143	0.150
	LTE Band 2	20Mhz	50	0	Bottom Side	10mm	18900	1880	1.050	0.441	0.463



	LTE Band 4	20Mhz	1	0	Front Side	10mm	20050	1720	1.107	0.806	0.892
21#	LTE Band 4	20Mhz	1	0	Back Side	10mm	20050	1720	1.107	0.911	1.008
	LTE Band 4	20Mhz	1	0	Right Side	10mm	20050	1720	1.107	0.382	0.423
	LTE Band 4	20Mhz	1	0	Left Side	10mm	20050	1720	1.107	0.269	0.298
	LTE Band 4	20Mhz	1	0	Bottom Side	10mm	20050	1720	1.107	0.832	0.921
	LTE Band 4	20Mhz	1	0	Front Side	10mm	20170	1732.5	1.016	0.738	0.750
	LTE Band 4	20Mhz	1	0	Front Side	10mm	20300	1745	1.021	0.817	0.834
	LTE Band 4	20Mhz	1	0	Back Side	10mm	20170	1732.5	1.016	0.763	0.775
	LTE Band 4	20Mhz	1	0	Back Side	10mm	20300	1745	1.021	0.908	0.927
	LTE Band 4	20Mhz	1	0	Bottom Side	10mm	20170	1732.5	1.016	0.686	0.697
	LTE Band 4	20Mhz	1	0	Bottom Side	10mm	20300	1745	1.021	0.650	0.664
	LTE Band 4	20Mhz	50	0	Front Side	10mm	20050	1720	1.009	0.464	0.468
	LTE Band 4	20Mhz	50	0	Back Side	10mm	20050	1720	1.009	0.621	0.627
	LTE Band 4	20Mhz	50	0	Right Side	10mm	20050	1720	1.009	0.321	0.324
	LTE Band 4	20Mhz	50	0	Left Side	10mm	20050	1720	1.009	0.170	0.172
	LTE Band 4	20Mhz	50	0	Bottom Side	10mm	20050	1720	1.009	0.549	0.554
	LTE Band 4	20Mhz	100	0	Front Side	10mm	20050	1720	1.107	0.689	0.762
	LTE Band 4	20Mhz	100	0	Back Side	10mm	20050	1720	1.107	0.680	0.753
	LTE Band 4	20Mhz	100	0	Bottom Side	10mm	20050	1720	1.107	0.551	0.610
	LTE Band 12	10Mhz	1	49	Front Side	10mm	23095	707.5	1.030	0.100	0.103
22#	LTE Band 12	10Mhz	1	49	Back Side	10mm	23095	707.5	1.030	0.171	0.176
	LTE Band 12	10Mhz	1	49	Right Side	10mm	23095	707.5	1.030	0.057	0.059
	LTE Band 12	10Mhz	1	49	Left Side	10mm	23095	707.5	1.030	0.087	0.090
	LTE Band 12	10Mhz	1	49	Bottom Side	10mm	23095	707.5	1.030	0.003	0.003
	LTE Band 12	10Mhz	25	0	Front Side	10mm	23095	707.5	1.064	0.077	0.082
	LTE Band 12	10Mhz	25	0	Back Side	10mm	23095	707.5	1.064	0.120	0.128
	LTE Band 12	10Mhz	25	0	Right Side	10mm	23095	707.5	1.064	0.041	0.044
	LTE Band 12	10Mhz	25	0	Left Side	10mm	23095	707.5	1.064	0.073	0.078
	LTE Band 12	10Mhz	25	0	Front Side	10mm	23095	707.5	1.064	0.077	0.082
	LTE Band 17	10Mhz	1	49	Front Side	10mm	23800	711	1.035	0.070	0.072
23#	LTE Band 17	10Mhz	1	49	Back Side	10mm	23800	711	1.035	0.134	0.139
	LTE Band 17	10Mhz	1	49	Right Side	10mm	23800	711	1.035	0.061	0.063
	LTE Band 17	10Mhz	1	49	Left Side	10mm	23800	711	1.035	0.059	0.061
	LTE Band 17	10Mhz	1	49	Front Side	10mm	23800	711	1.035	0.070	0.072
	LTE Band 17	10Mhz	25	0	Front Side	10mm	23800	711	1.146	0.069	0.079
	LTE Band 17	10Mhz	25	0	Back Side	10mm	23800	711	1.146	0.123	0.141



	LTE Band 17	10Mhz	25	0	Right Side	10mm	23800	711	1.146	0.032	0.037
	LTE Band 17	10Mhz	25	0	Left Side	10mm	23800	711	1.146	0.059	0.068
	LTE Band 17	10Mhz	25	0	Bottom Side	10mm	23800	711	1.146	0.014	0.016

<WLAN2.4GHZ &WLAN 5GHZ >

Plot No.	Band	Test Position	Gap (mm)	Ch.	Freq. (MHz)	Tune-up Scaling Factor	Measured 1g SAR (W/kg)	Reported 1g SAR (W/kg)
	WLAN2.4GHz	Front Side	10mm	6	2437	1.026	0.114	0.117
24#	WLAN2.4GHz	Back Side	10mm	6	2437	1.026	0.107	0.110
	WLAN2.4GHz	Right Side	10mm	6	2437	1.026	0.013	0.013
	WLAN2.4GHz	Left Side	10mm	6	2437	1.026	0.065	0.067
	WLAN2.4GHz	Top Side	10mm	6	2437	1.026	0.068	0.070
	WLAN5GHz	Front Side	10mm	48	5240	1.074	0.025	0.027
25#	WLAN5GHz	Back Side	10mm	48	5240	1.074	0.084	0.090
	WLAN5GHz	Right Side	10mm	48	5240	1.074	0.034	0.037
	WLAN5GHz	Left Side	10mm	48	5240	1.074	0.067	0.072
	WLAN5GHz	Top Side	10mm	48	5240	1.074	0.043	0.046
	WLAN5GHz	Front Side	10mm	60	5300	1.076	0.062	0.067
26#	WLAN5GHz	Back Side	10mm	60	5300	1.076	0.146	0.157
	WLAN5GHz	Right Side	10mm	60	5300	1.076	0.104	0.112
	WLAN5GHz	Left Side	10mm	60	5300	1.076	0.071	0.076
	WLAN5GHz	Top Side	10mm	60	5300	1.076	0.104	0.112
	WLAN5GHz	Front Side	10mm	120	5600	1.122	0.137	0.154
27#	WLAN5GHz	Back Side	10mm	120	5600	1.122	0.245	0.275
	WLAN5GHz	Right Side	10mm	120	5600	1.122	0.049	0.055
	WLAN5GHz	Left Side	10mm	120	5600	1.122	0.054	0.061
	WLAN5GHz	Top Side	10mm	120	5600	1.122	0.118	0.132
28#	WLAN5GHz	Front Side	10mm	159	5795	1.117	0.114	0.127
	WLAN5GHz	Back Side	10mm	159	5795	1.117	0.048	0.054
	WLAN5GHz	Right Side	10mm	159	5795	1.117	0.038	0.042
	WLAN5GHz	Left Side	10mm	159	5795	1.117	0.065	0.073
	WLAN5GHz	Top Side	10mm	159	5795	1.117	0.093	0.104



14. Repeated SAR Measurement

In accordance with published RF Exposure KDB procedure 865664 D01 SAR measurement 100 MHz to 6 GHz. These additional measurements are repeated after the completion of all measurements requiring the same head or body tissue-equivalent medium in a frequency band. The test device should be returned to ambient conditions (normal room temperature) with the battery fully charged before it is re-mounted on the device holder for the repeated measurement(s) to minimize any unexpected variations in the repeated results.

- 1) Repeated measurement is not required when the original highest measured SAR is < 0.80 W/kg; steps 2) through 4) do not apply.
- 2) When the original highest measured SAR is ≥ 0.80 W/kg, repeat that measurement once.
- 3) Perform a second repeated measurement only if the ratio of largest to smallest SAR for the original and first repeated measurements is > 1.20 or when the original or repeated measurement is ≥ 1.45 W/kg (~ 10% from the 1-g SAR limit).
- 4) Perform a third repeated measurement only if the original, first or second repeated measurement is ≥ 1.5 W/kg and the ratio of largest to smallest SAR for the original, first and second repeated measurements is > 1.20 .

Plot No.	Band	BW (MHz)	RB Size	RB offset	Test Position	Gap (mm)	Ch.	Freq. (MHz)	Tune-up Scaling Factor	Measured 1g SAR (W/kg)	Reported 1g SAR (W/kg)
OR	LTE Band 4	20Mhz	1	0	Back Side	10mm	20050	1720	1.107	0.911	1.008
	LTE Band 4	20Mhz	1	0	Back Side	10mm	20050	1720	1.107	0.903	0.999

15. Multiple Transmitters Evaluation

Stand-alone SAR

Test distance: 10mm			
Band	Highest power(mW) per tune up	1-g SAR test threshold	Test required?
Wi-Fi (2.4GHz)	35.50	$\frac{[(\text{max. power of channel, including tune-up tolerance, mW})/(\text{min. test separation distance, mm})] \cdot [\sqrt{f}(\text{GHz})]}{\leq 3.0 \text{ for 1-g SAR}}$	Yes
Wi-Fi (5.2G)	16.00		Yes
Wi-Fi (5.3GHz)	16.00		Yes
Wi-Fi (5.5GHz)	22.00		Yes
Wi-Fi (5.8GHz)	18.00		Yes
Bluetooth	2.82		No

The SAR test for BT is not required.

The BT stand-alone SAR is not required, the standalone SAR must be estimated according to following to determine simultaneous transmission SAR test exclusion:

(max. power of channel, including tune-up tolerance, mW)/(min. test separation distance, mm) · [√f(GHz)/x] W/kg for test separation distances ≤ 50 mm;

where $x = 7.5$ for 1-g SAR, and $x = 18.75$ for 10-g SAR.

(Max power=2.82 mW; min. test separation distance= 5mm for Head; $f=2.4\text{GHz}$)

BT estimated Head SAR =0.117W/Kg (1g)

(Max power=2.82 mW; min. test separation distance= 10mm for Body; $f=2.4\text{GHz}$)

BT estimated Body SAR =0.058W/Kg (1g)

**Simultaneous Evaluation:**

No.	Simultaneous transmission Condition	Head	Hotspot	Body-worn
	GSM/GPRS/EDGE + WLAN 2.4GHz	Yes	Yes	Yes
	WCDMA + WLAN 2.4GHz	Yes	Yes	Yes
	LTE + WLAN 2.4GHz	Yes	Yes	Yes
	GSM/GPRS/EDGE + WLAN 5GHz	Yes	Yes	Yes
	WCDMA + WLAN 5GHz	Yes	Yes	Yes
	LTE + WLAN 5GHz	Yes	Yes	Yes
	GSM/GPRS/EDGE + Bluetooth	Yes	Yes	Yes
	WCDMA + Bluetooth	Yes	Yes	Yes
	LTE + Bluetooth	Yes	Yes	Yes

Note:

1. When the user enables the personal wireless router functions for the handset, actual operations include simultaneous transmission of both the Wi-Fi transmitter and another WWAN transmitter. Both transmitter often do not transmit at the same transmitting frequency and thus cannot be evaluated for SAR under actual use conditions. The "Portable Hotspot" feature on the handset was NOT activated, to ensure the SAR measurements were evaluated for a single transmission frequency RF signal.
2. The hotspot SAR result may overlap with the body-worn accessory SAR requirements, per KDB 941225 D06, the more conservative configurations can be considered, thus excluding some unnecessary body-worn accessory SAR tests.
3. GSM supports voice and data transmission, though not simultaneously. WCDMA supports voice and data transmission simultaneously.
4. Simultaneous Transmission SAR evaluation is not required for BT and Wi-Fi , because the software mechanism have been incorporated to guarantee that the WLAN and Bluetooth transmitters would not simultaneously operate.
5. Per KDB 447498D01v06, Simultaneous Transmission SAR Evaluation procedures is as followed:
Step 1: If sum of 1 g SAR < 1.6 W/kg, Simultaneous SAR measurement is not required.
Step 2: If sum of 1 g SAR > 1.6 W/kg, ratio of SAR to peak separation distance for pair of transmitters calculated.
Step 3: If the ratio of SAR to peak separation distance is ≤ 0.04 , Simultaneous SAR measurement is not required.



Step 4: If the ratio of SAR to peak separation distance is > 0.04 , Simultaneous SAR measurement is required and simultaneous transmission SAR value is calculated.

(The ratio is determined by: $(SAR1 + SAR2) \wedge 1.5/Ri \leq 0.04$,

Ri is the separation distance between the peak SAR locations for the antenna pair in mm)

Applicable Multiple Scenario Evaluation

Test Position	Main Ant. SAR _{Max} (W/Kg)	Bluetooth SAR (W/Kg)	Wi-Fi2.4G SAR _{Max} (W/Kg)	Wi-Fi5G SAR _{Max} (W/Kg)	Σ1-g SAR _{Max} (W/Kg)		
					BT& Main Ant.	Wi-Fi 2.4G&Main Ant.	Wi-Fi 5G&Main Ant.
Head	0.723	0.124	0.434	0.172	0.847	1.157	0.895
Hotspot	1.008	0.062	0.117	0.275	1.070	1.125	1.283
Body-worn	1.008	0.062	0.117	0.275	1.070	1.125	1.283

Simultaneous Transmission SAR evaluation is not required for Wi-Fi and WCDMA&GSM<E, because the sum of 1g SAR_{Max} is **1.283** W/Kg < 1.6 W/Kg for Wi-Fi and WCDMA&GSM<E.

Simultaneous Transmission SAR evaluation is not required for BT and WCDMA&GSM<E, because the sum of 1g SAR_{Max} is **1.070**W/Kg < 1.6 W/Kg for BT and WCDMA&GSM<E.

(According to KDB 447498D01v06, the sum of the Highest reported SAR of each antenna does not exceed the limit, simultaneous transmission SAR evaluation is not required.)

_____ END OF REPORT _____



Annex A General Information

1. Identification of the Responsible Testing Laboratory

Company Name:	Shenzhen Morlab Communications Technology Co., Ltd.
Department:	Morlab Laboratory
Address:	FL.3, Building A, FeiYang Science Park, No.8 LongChang Road, Block 67, BaoAn District, ShenZhen, GuangDong Province, P. R. China
ResponsibleTest Lab Manager:	Mr. Su Feng
Telephone:	+86 755 36698555
Facsimile:	+86 755 36698525

2. Identification of the Responsible Testing Location

Name:	Shenzhen Morlab Communications Technology Co., Ltd. Morlab Laboratory
Address:	FL.3, Building A, FeiYang Science Park, No.8 LongChang Road, Block 67, BaoAn District, ShenZhen, GuangDong Province, P. R. China

NOTE: This document is issued by MORLAB, the test report shall not be reproduced except in full without prior written permission of the company. The test results apply only to the particular sample(s) tested and to the specific tests carried out which is available on request for validation and information confirmed at our website.



3. List of Test Equipments

No.	Instrument	Type	Cal. Date	Cal. Due
1	PC	Dell (Pentium IV 2.4GHz, SN:X10-23533)	(n.a)	(n.a)
2	Network Emulator	Aglient (8960, SN:10752)	2017-5-24	1year
3	Network Emulator	Rohde&Schwarz (CMW500,SN:124534)	2017-5-25	1year
4	Network Analyzer	Agilent(E5071B ,SN:MY42404762)	2017-5-25	1year
5	Voltmeter	Keithley (2000, SN:1000572)	2017-7-8	1year
6	Synthesizer	Rohde&Schwarz (SML_03, SN:101868)	2017-8-24	1year
7	Signal Generator	Rohde&Schwarz (SMP_02)	2017-7-8	1year
8	Power Amplifier	PRANA (Ap32 SV125AZ)	2017-7-8	1year
9	Power Meter	Agilent (E4416A, SN:MY45102093)	2017-7-8	1year
10	Power Sensor	Agilent (N8482A, SN:MY41091706)	2017-7-8	1year
11	Power Meter	Rohde&Schwarz (NRVD, SN:101066)	2017-7-8	1year
12	Power Sensor	MA2411B	2017-7-8	1year
13	Directional coupler	Giga-tronics(SN:1829112)	2017-7-24	1year
14	Probe	Satimo (SN:SN 37/08 EP80)	2017-7-5	1year
15	Probe	Satimo (SN:SN 37/13 EPG193)	2017-7-5	1year
16	Dielectric Probe Kit	Agilent (85033E)	2017-7-5	1year
17	Phantom	Satimo (SN:SN_36_08_SAM62)	N/A	N/A
18	Liquid	Satimo(Last Calibration: 2018-04-05 to 2018-04-17)	N/A	N/A
19	Dipole 750MHz	Satimo (SN30/13 DIP0G750)	2017-7-5	1year
20	Dipole 835MHz	Satimo (SN 20/08 DIP0C99)	2017-7-5	1year
21	Dipole 1800MHz	Satimo (SN 36/08 DIP0F101)	2017-7-5	1year
22	Dipole 2000MHz	Satimo (SN 20/08 DIP0I102)	2017-7-5	1year
23	Dipole 2450MHz	Satimo (SN 30/13 DIP2G450-263)	2017-7-5	1year
24	Dipole 5-6GHz	Satimo (SN 41/12 WGA21)	2017-7-5	1year
25	Thermo meter	KTJ(mode-01)	2017-5-10	1year

NOTE: This document is issued by MORLAB, the test report shall not be reproduced except in full without prior written permission of the company. The test results apply only to the particular sample(s) tested and to the specific tests carried out which is available on request for validation and information confirmed at our website.

Annex B Test Setup Photos

Head

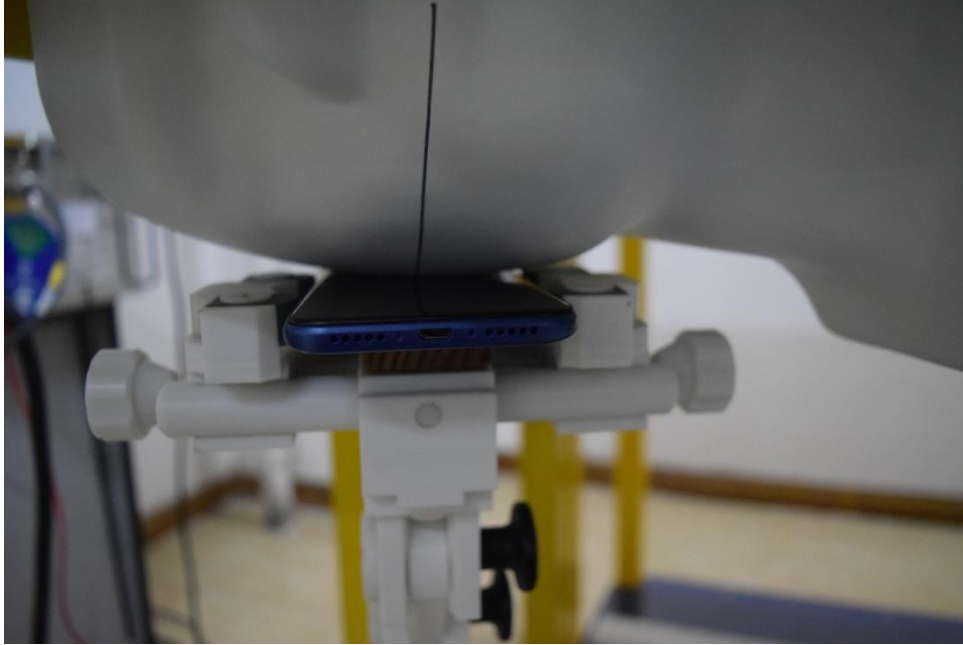

Right Cheek

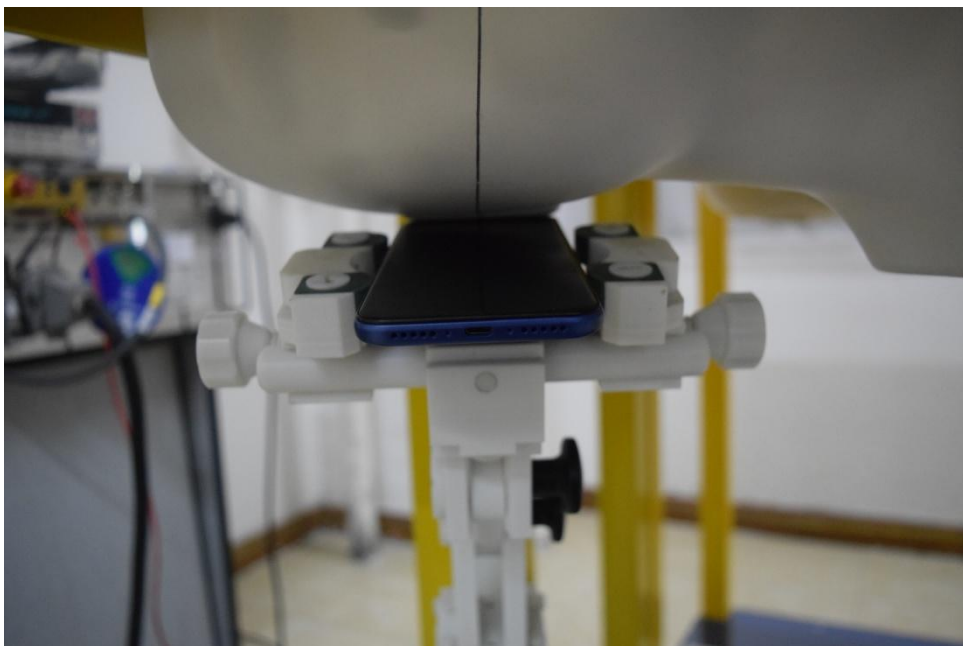

Right Tilt

NOTE: This document is issued by MORLAB, the test report shall not be reproduced except in full without prior written permission of the company. The test results apply only to the particular sample(s) tested and to the specific tests carried out which is available on request for validation and information confirmed at our website.

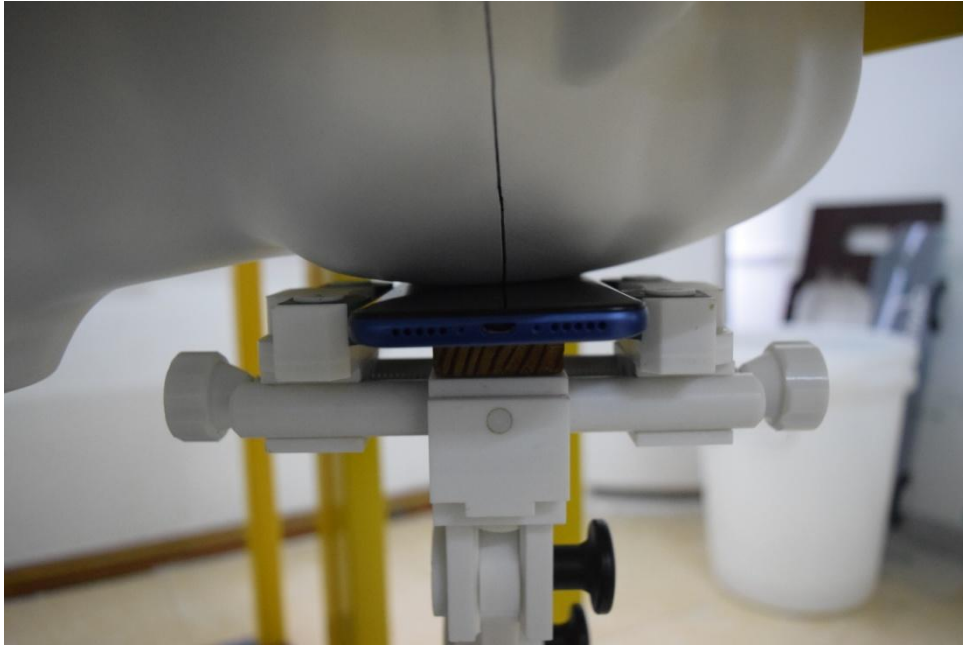

Left Cheek



Left Tilt

Body

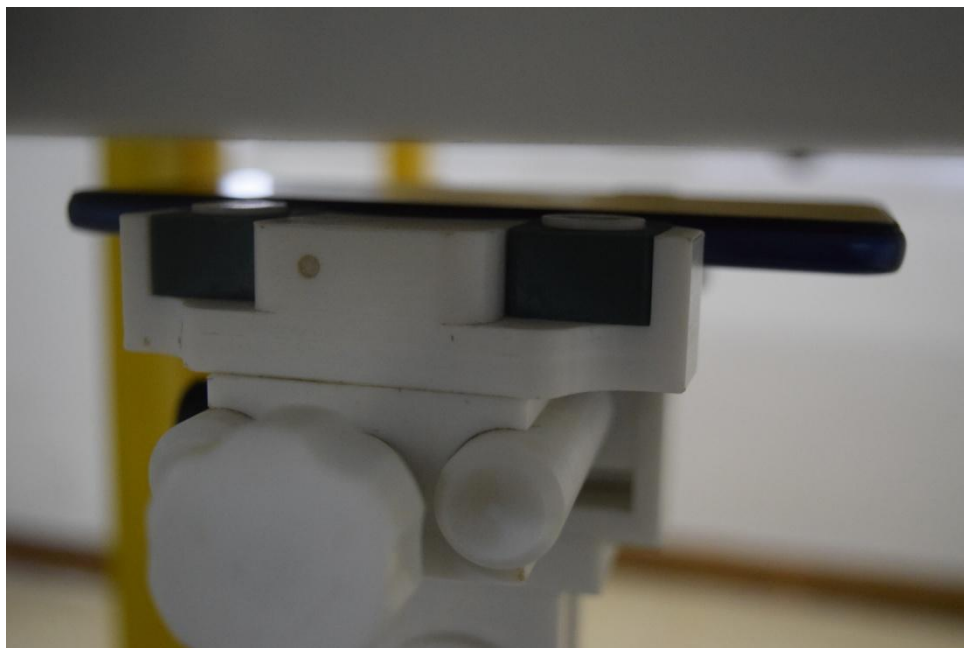

Front Side_10mm

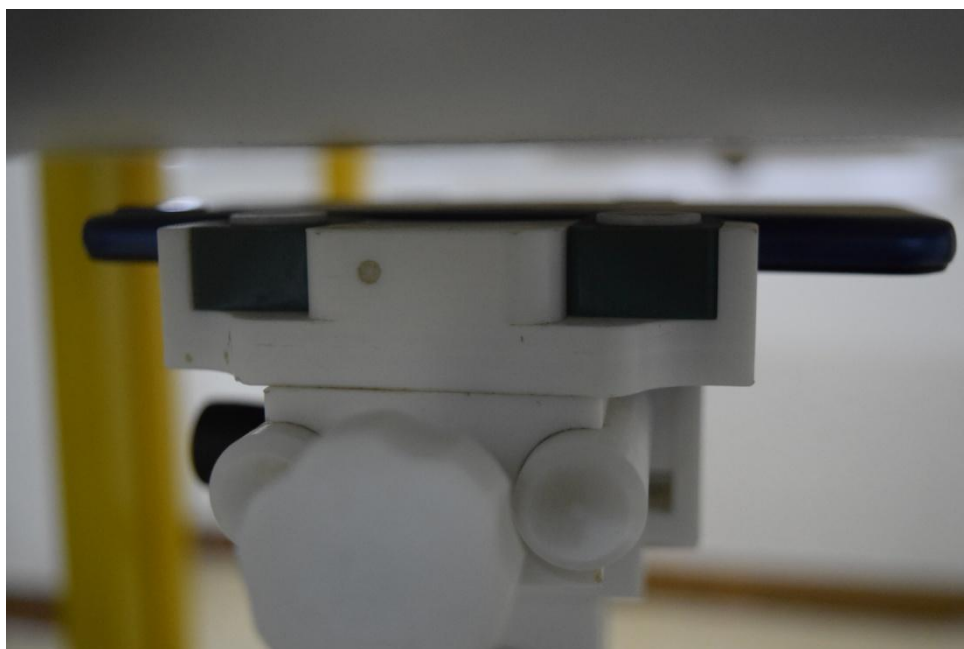

Back Side_10mm

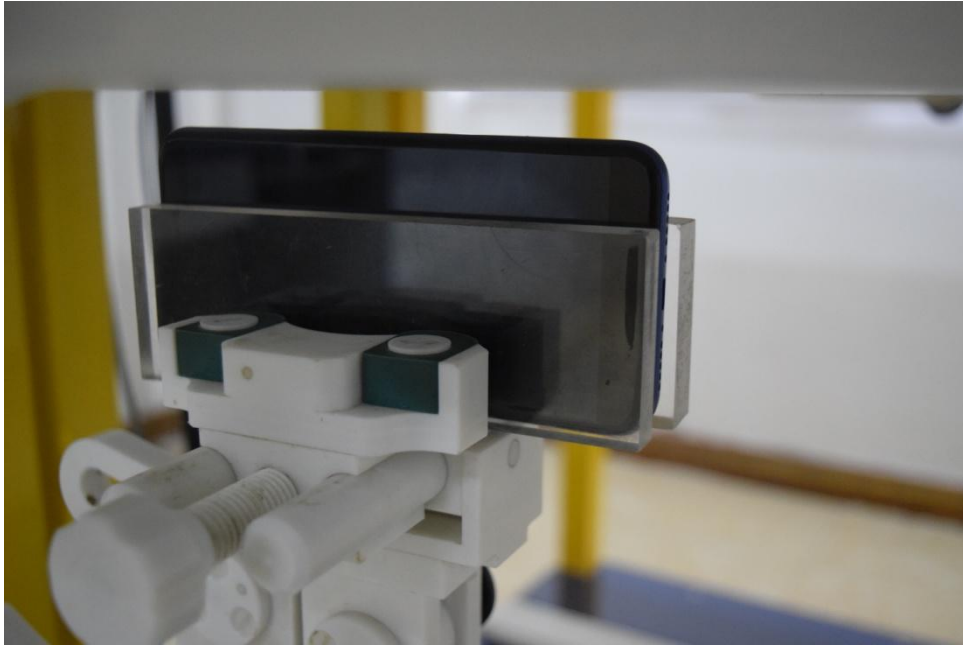

Right Side_10mm

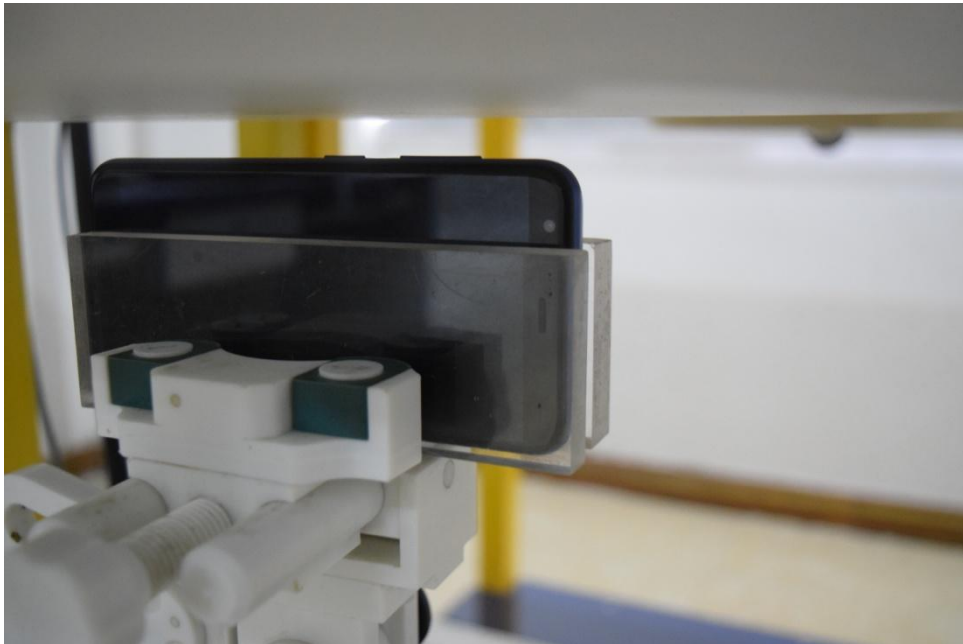

Left Side_10mm



Top Side_10mm



Bottom Side_10mm

Annex C Plots of System Performance Check

System Performance Check Data (750MHz Head)

Type: Phone measurement (Complete)
 Area scan resolution: dx=8mm,dy=8mm
 Zoom scan resolution: dx=8mm, dy=8mm, dz=5mm
 Date of measurement: 2018.04.08
 Measurement duration: 13 minutes 28 seconds

A. Experimental conditions.

Phantom File	surf_sam_plan.txt
Phantom	Flat
Device Position	
Band	750MHz
Channels	
Signal	CW

B. SAR Measurement Results

Frequency (MHz)	750.000000
Relative permittivity (real part)	41.350601
Conductivity (S/m)	0.885608
Power drift (%)	1.030000
Ambient Temperature:	22.6°C
Liquid Temperature:	21.2°C
ConvF:	6.44
Crest factor:	1:1

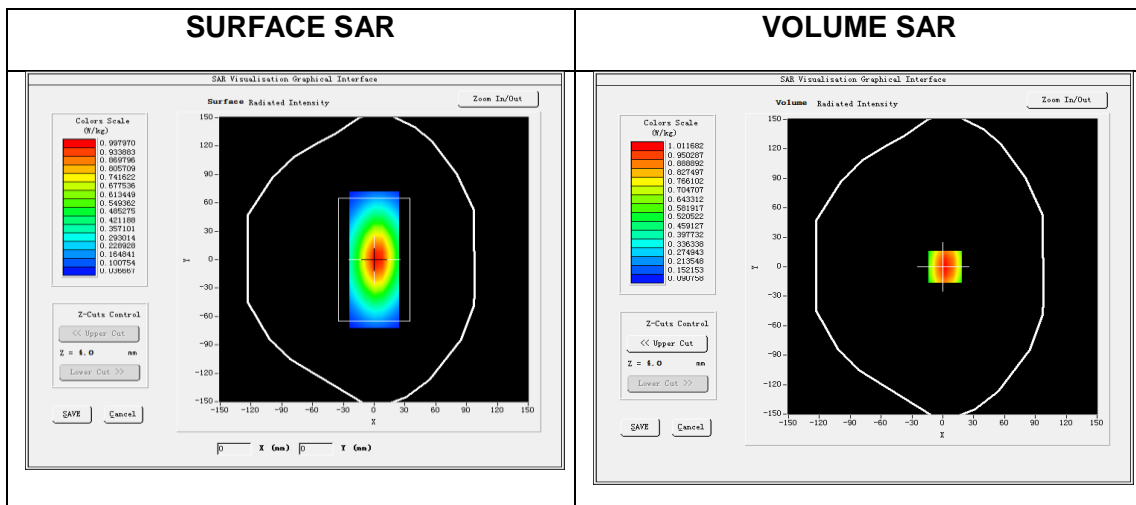

Maximum location: X=2.00, Y=0.00

SAR 10g (W/Kg)	0.539271
SAR 1g (W/Kg)	0.783215

Z Axis Scan

Z (mm)	0.00	4.00	9.00	14.00	19.00	24.00	29.00
SAR (W/Kg)	1.4197	1.0117	0.6692	0.4600	0.3210	0.2279	0.1624

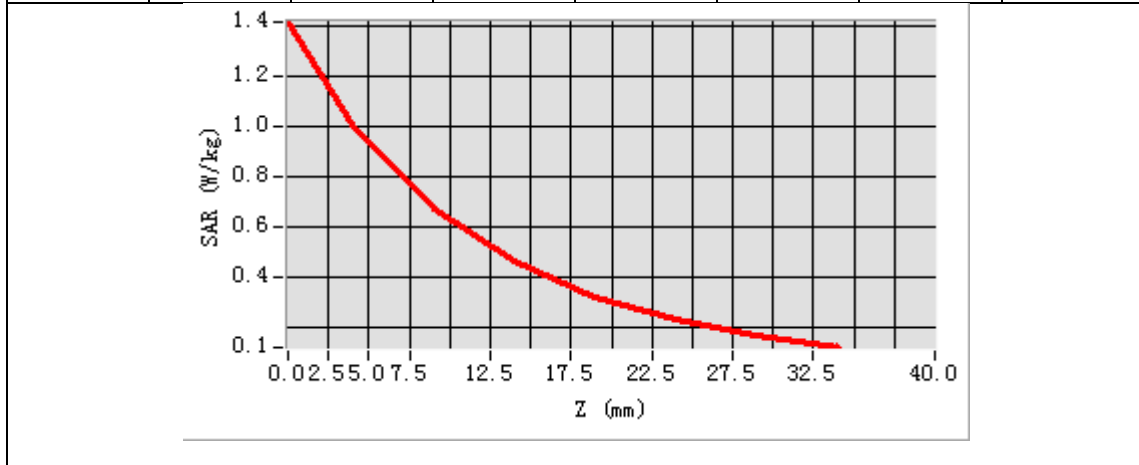

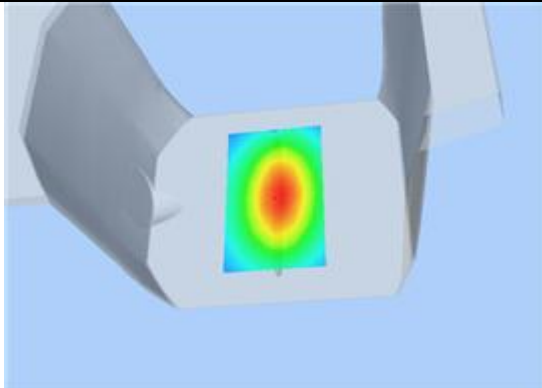
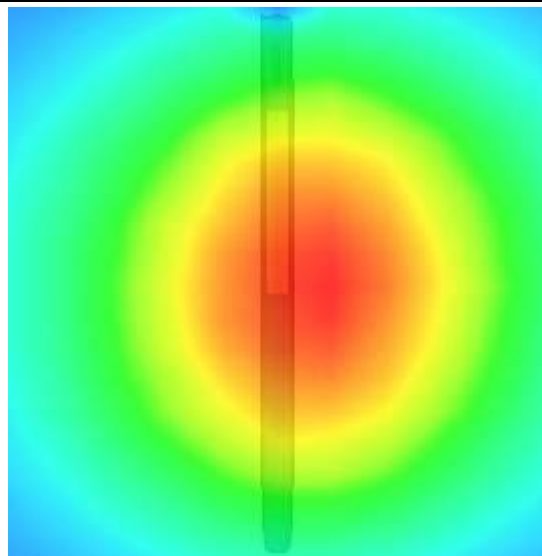
3D scene shot	Hot spot position
 <p>A 3D perspective view of a grey device with a rectangular hot spot on its top surface. The hot spot is color-coded from blue (low) to red (high), with a vertical color bar on the right side of the hot spot area.</p>	 <p>A 2D heatmap showing the spatial distribution of the hot spot. The color scale ranges from blue (low SAR) to red (high SAR), with a vertical color bar on the right side of the heatmap.</p>



System Performance Check Data (750MHz Body)

Type: Phone measurement (Complete)
 Area scan resolution: dx=8mm,dy=8mm
 Zoom scan resolution: dx=8mm, dy=8mm, dz=5mm
 Date of measurement: 2018.04.05
 Measurement duration: 13 minutes 36 seconds

A. Experimental conditions.

Phantom File	surf_sam_plan.txt
Phantom	Flat
Device Position	
Band	750MHz
Channels	
Signal	CW

B. SAR Measurement Results

Band SAR

Frequency (MHz)	750.000000
Relative permittivity (real part)	53.517799
Conductivity (S/m)	1.031025
Power drift (%)	0.320000
Ambient Temperature:	22.6°C
Liquid Temperature:	21.2°C
ConvF:	6.68
Crest factor:	1:1

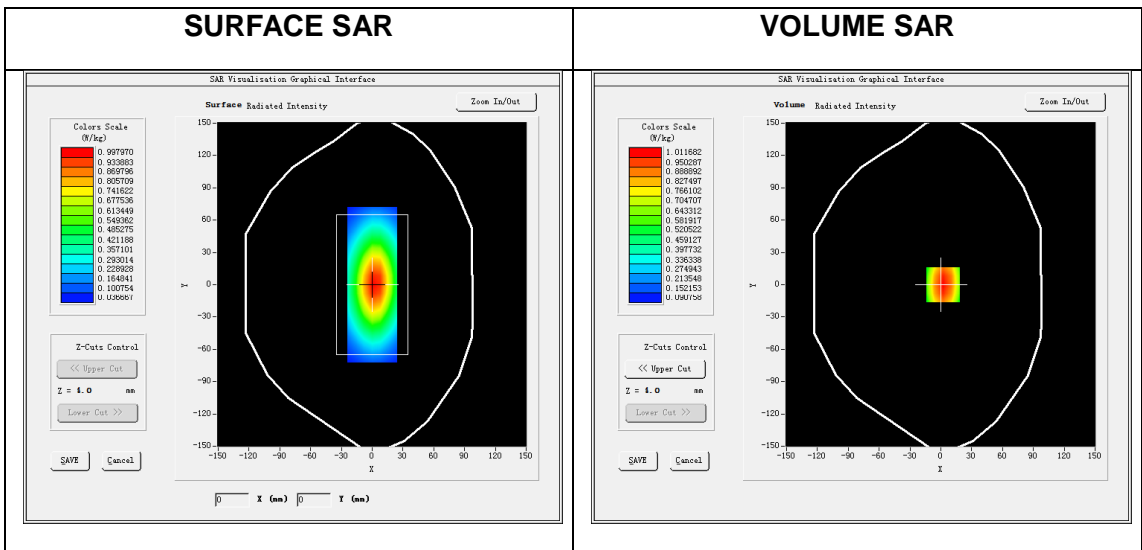

Maximum location: X=2.00, Y=0.00

SAR 10g (W/Kg)	0.609663
SAR 1g (W/Kg)	0.905411

Z Axis Scan

Z (mm)	0.00	4.00	9.00	14.00	19.00	24.00	29.00
SAR (W/Kg)	1.4197	1.0117	0.6692	0.4600	0.3210	0.2279	0.1624

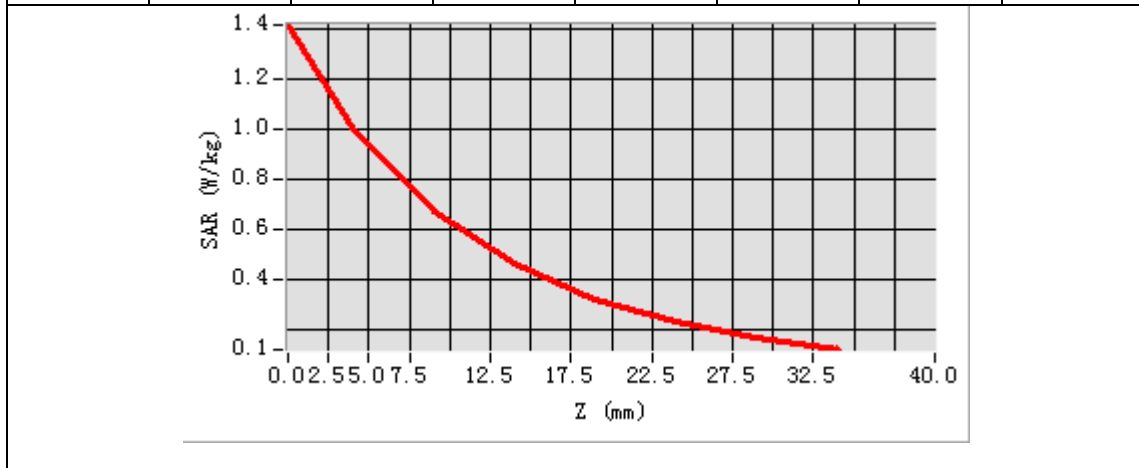

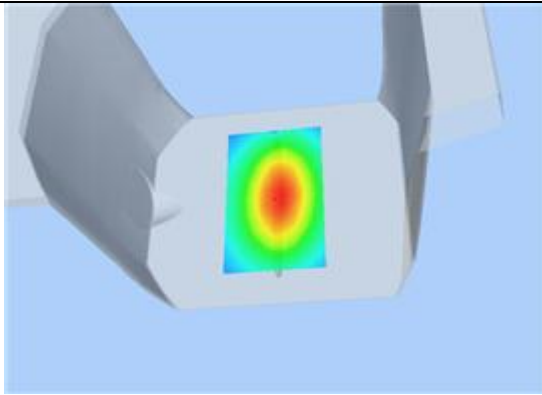
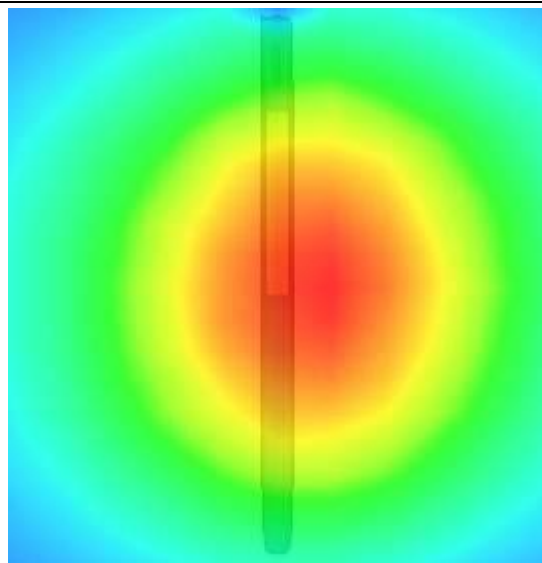
3D scene shot	Hot spot position
	



System Performance Check Data (835MHz Head)

Type: Phone measurement (Complete)
 Area scan resolution: dx=8mm,dy=8mm
 Zoom scan resolution: dx=8mm, dy=8mm, dz=5mm
 Date of measurement: 2018.04.12
 Measurement duration: 13 minutes 35 seconds

A. Experimental conditions.

Phantom File	surf_sam_plan.txt
Phantom	Flat
Device Position	
Band	835MHz
Channels	
Signal	CW

B. SAR Measurement Results

Frequency (MHz)	835.000000
Relative permittivity (real part)	41.182291
Conductivity (S/m)	0.891718
Power drift (%)	1.070000
Ambient Temperature:	22.6°C
Liquid Temperature:	21.2°C
ConvF:	6.13
Crest factor:	1:1

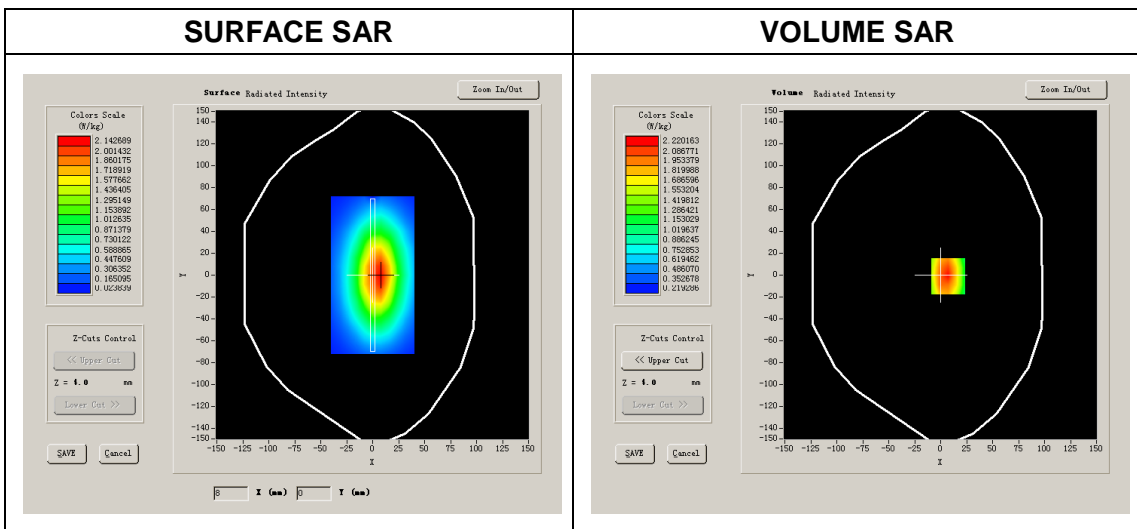

Maximum location: X=7.00, Y=-1.00

SAR 10g (W/Kg)	0.622151
SAR 1g (W/Kg)	0.968476

Z Axis Scan

Z (mm)	0.00	4.00	9.00	14.00	19.00	24.00	29.00
SAR (W/Kg)	0.0000	2.5209	1.6629	1.1437	0.8075	0.5889	0.4143

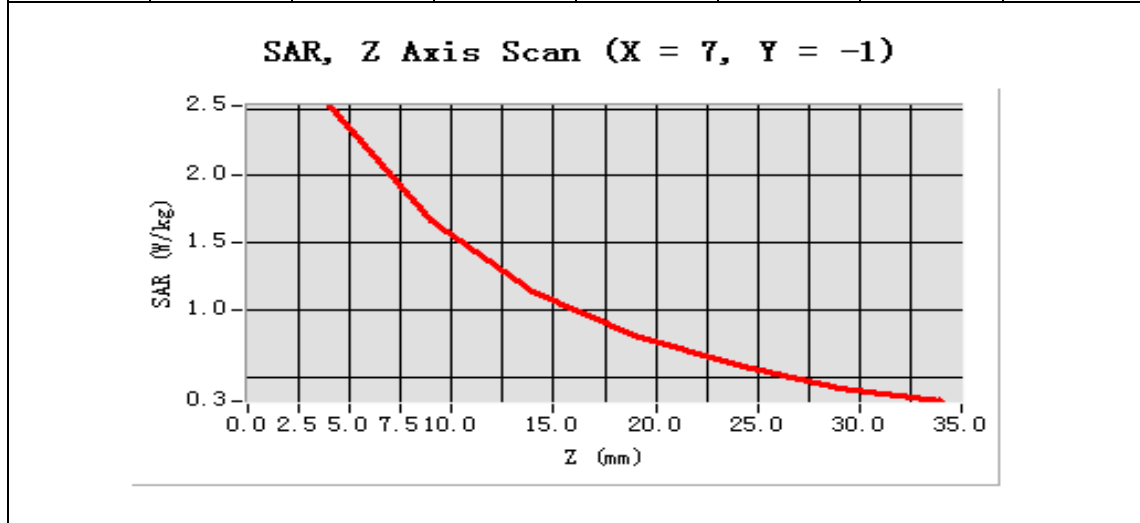

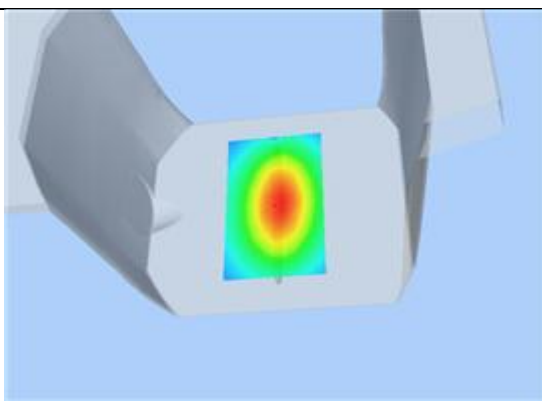
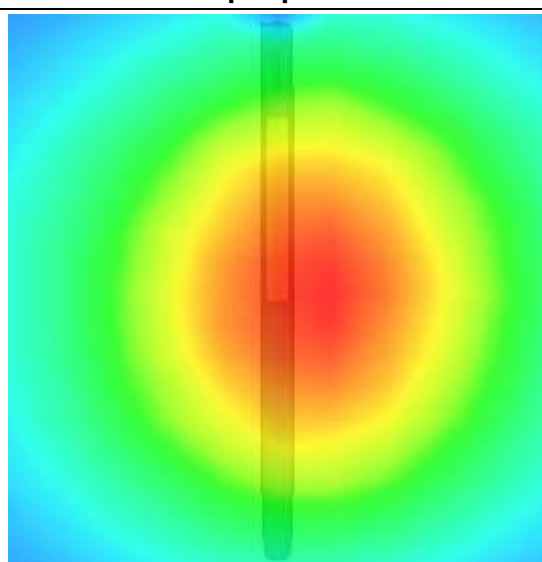
3D scen shot	Hot spot position
	



System Performance Check Data (835MHz Body)

Type: Phone measurement (Complete)
 Area scan resolution: dx=8mm,dy=8mm
 Zoom scan resolution: dx=8mm, dy=8mm, dz=5mm
 Date of measurement: 2018.04.11
 Measurement duration: 13 minutes 28 seconds

A. Experimental conditions.

Phantom File	surf_sam_plan.txt
Phantom	Flat
Device Position	
Band	835MHz
Channels	
Signal	CW

B. SAR Measurement Results

Band SAR

Frequency (MHz)	835.000000
Relative permittivity (real part)	55.382291
Conductivity (S/m)	0.921718
Power drift (%)	1.070000
Ambient Temperature:	22.6°C
Liquid Temperature:	21.2°C
ConvF:	6.37
Crest factor:	1:1

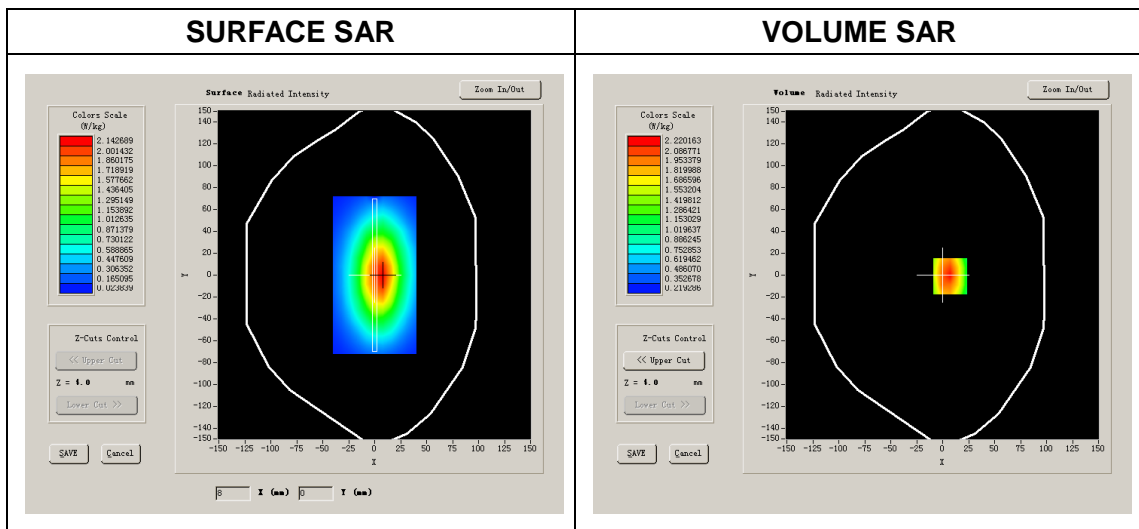

Maximum location: X=7.00, Y=-1.00

SAR 10g (W/Kg)	0.629151
SAR 1g (W/Kg)	0.986576

Z Axis Scan

Z (mm)	0.00	4.00	9.00	14.00	19.00	24.00	29.00
SAR (W/Kg)	0.0000	2.5209	1.6629	1.1437	0.8075	0.5889	0.4143

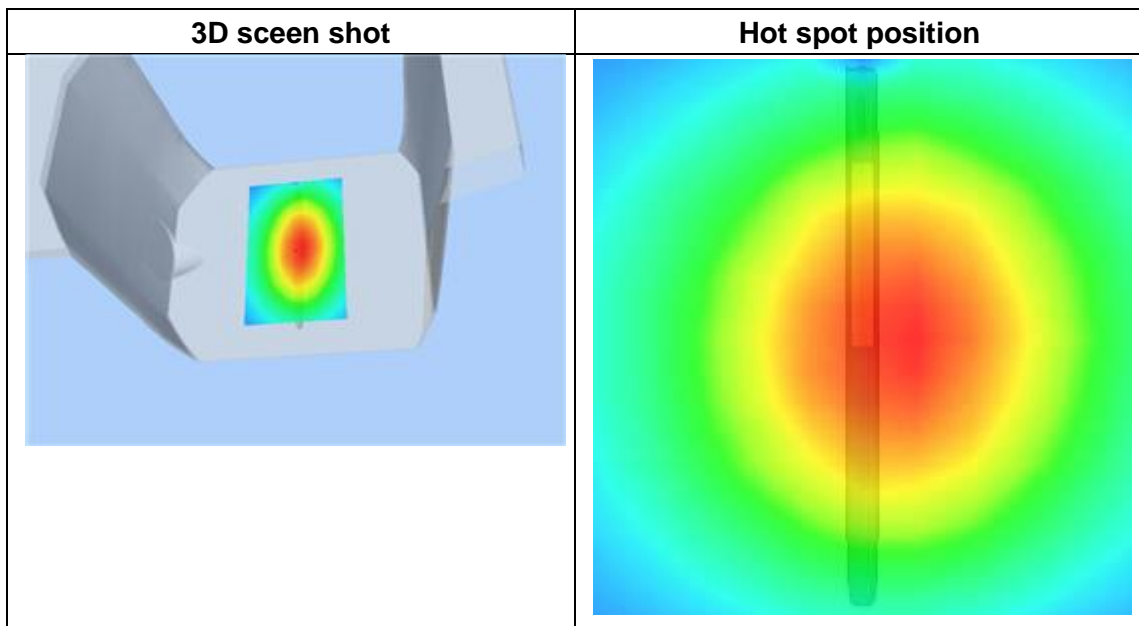
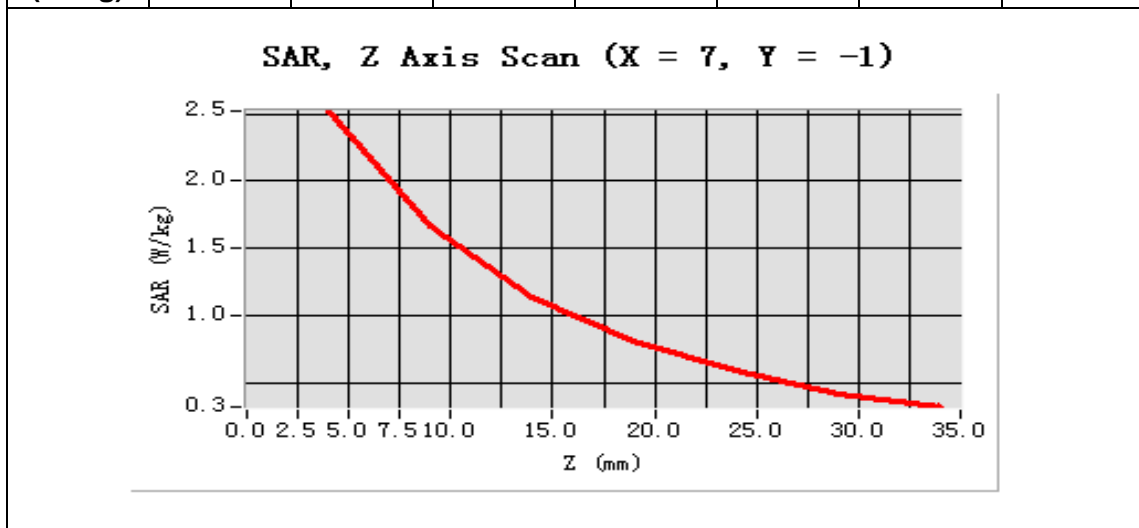



System Performance Check Data(1800MHz Head)

Type: Phone measurement (Complete)
 Area scan resolution: dx=8mm,dy=8mm
 Zoom scan resolution: dx=8mm, dy=8mm, dz=5mm
 Date of measurement: 2018.04.09
 Measurement duration: 13 minutes 27 seconds

A. Experimental conditions.

Phantom File	surf_sam_plan.txt
Phantom	Flat
Device Position	
Band	1800MHz
Channels	
Signal	CW

B. SAR Measurement Results

Band SAR

Frequency (MHz)	1800.000000
Relative permittivity (real part)	40.095167
Conductivity (S/m)	1.365073
Power drift (%)	0.310000
Ambient Temperature:	22.3°C
Liquid Temperature:	22.6°C
ConvF:	5.21
Crest factor:	1:1

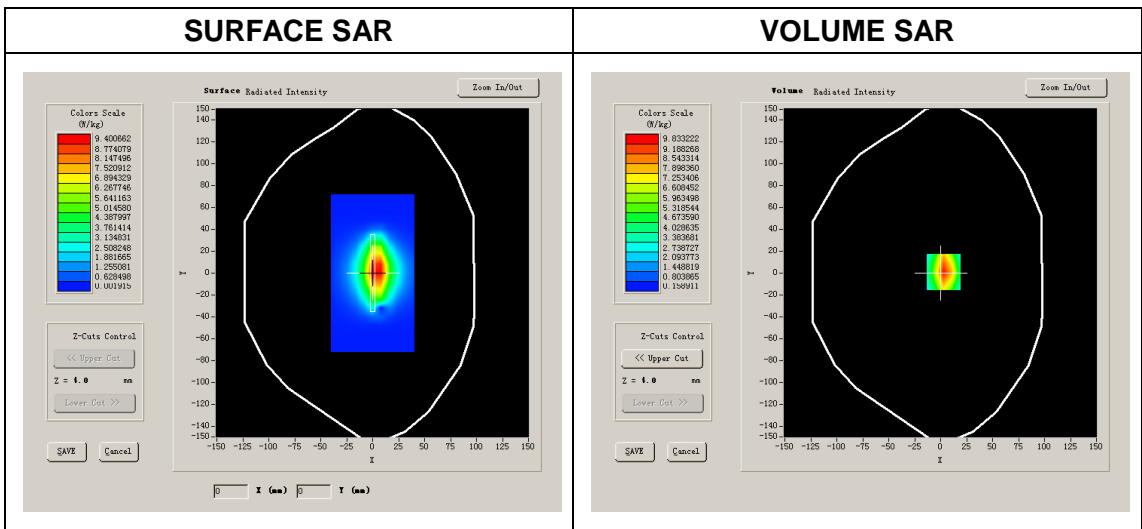

Maximum location: X=3.00, Y=1.00

SAR 10g (W/Kg)	2.048386
SAR 1g (W/Kg)	3.698154

Z Axis Scan

Z (mm)	0.00	4.00	9.00	14.00	19.00	24.00	29.00
SAR (W/Kg)	0.0000	10.0621	5.6445	3.6226	2.1642	1.4521	0.9078

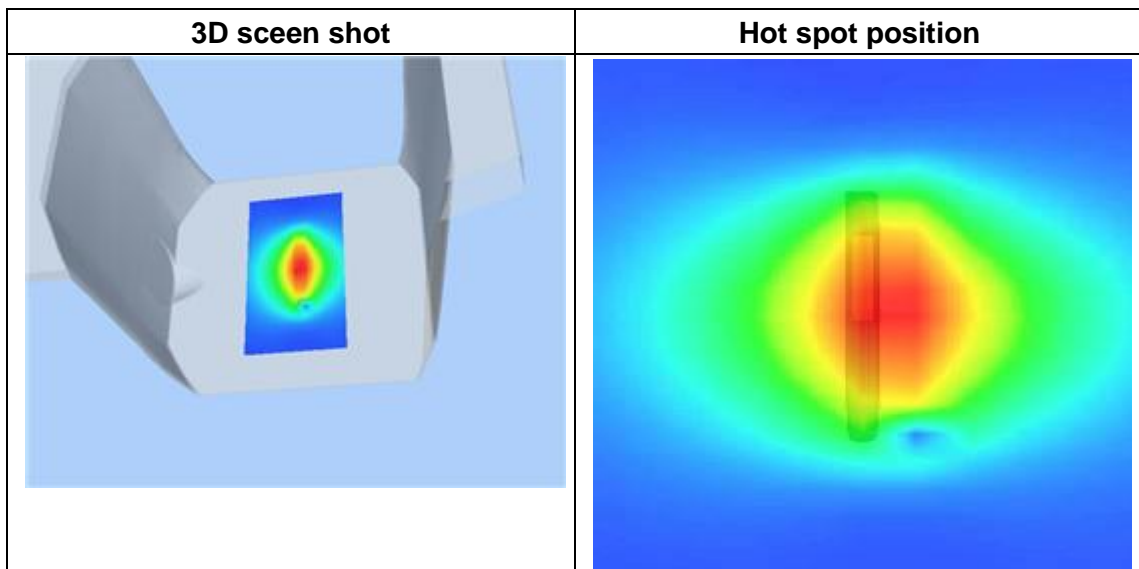
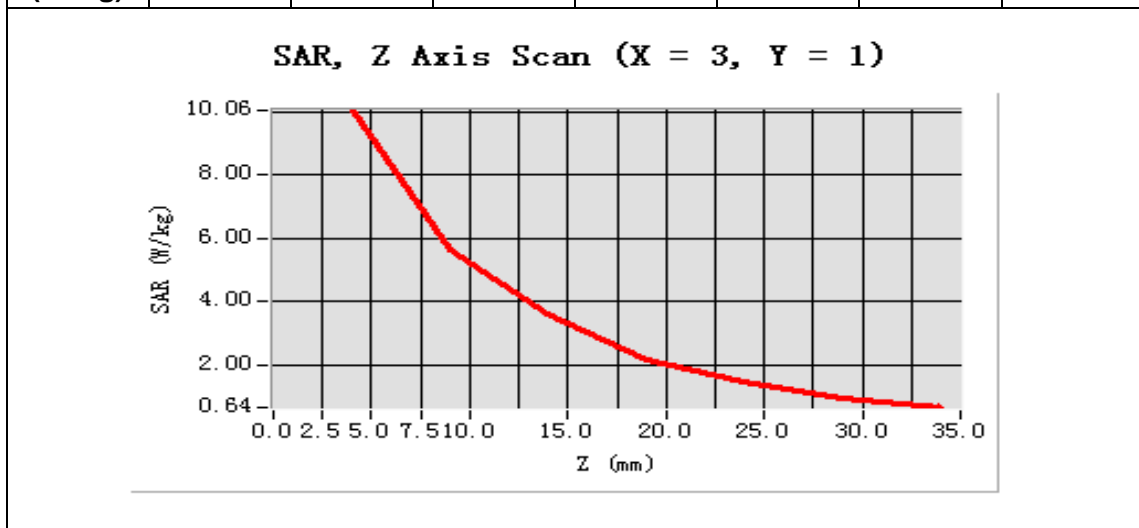



System Performance Check Data(1800MHz Body)

Type: Phone measurement (Complete)
 Area scan resolution: dx=8mm,dy=8mm
 Zoom scan resolution: dx=8mm, dy=8mm, dz=5mm
 Date of measurement: 2018.04.05
 Measurement duration: 13 minutes 27 seconds

A. Experimental conditions.

Phantom File	surf_sam_plan.txt
Phantom	Flat
Device Position	
Band	1800MHz
Channels	
Signal	CW

B. SAR Measurement Results

Band SAR

Frequency (MHz)	1800.000000
Relative permittivity (real part)	53.295167
Conductivity (S/m)	1.515073
Power drift (%)	0.310000
Ambient Temperature:	22.3°C
Liquid Temperature:	22.6°C
ConvF:	5.38
Crest factor:	1:1

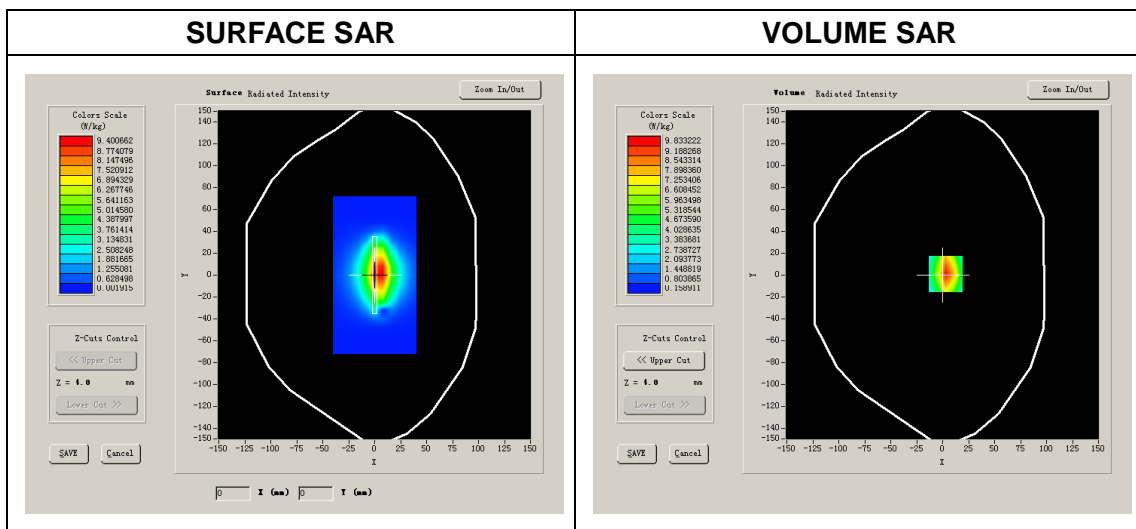

Maximum location: X=3.00, Y=1.00

SAR 10g (W/Kg)	2.038386
SAR 1g (W/Kg)	3.753454

Z Axis Scan

Z (mm)	0.00	4.00	9.00	14.00	19.00	24.00	29.00
SAR (W/Kg)	0.0000	10.0621	5.6445	3.6226	2.1642	1.4521	0.9078

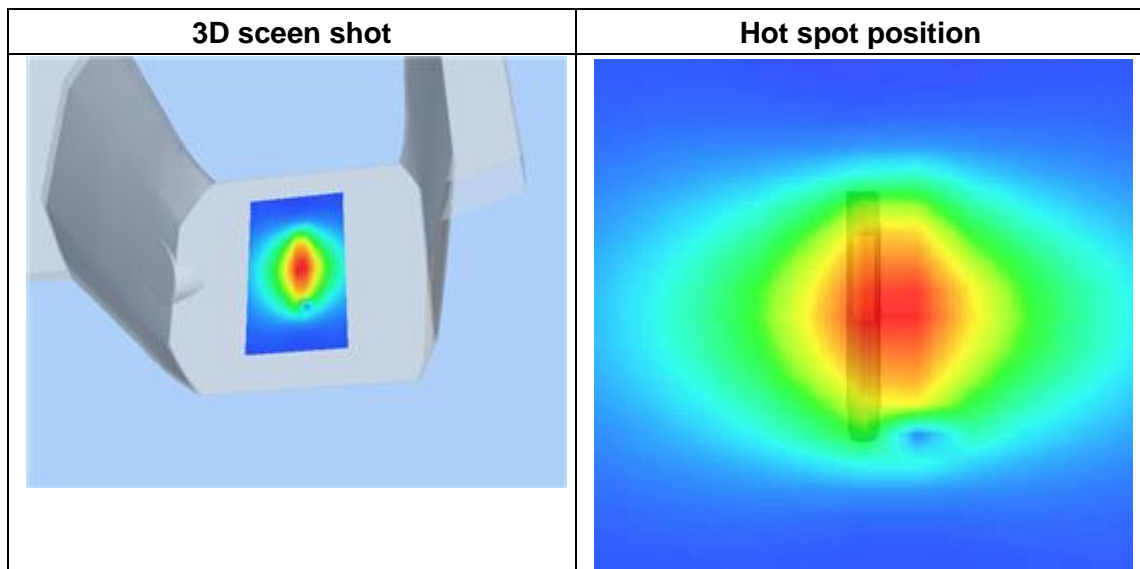
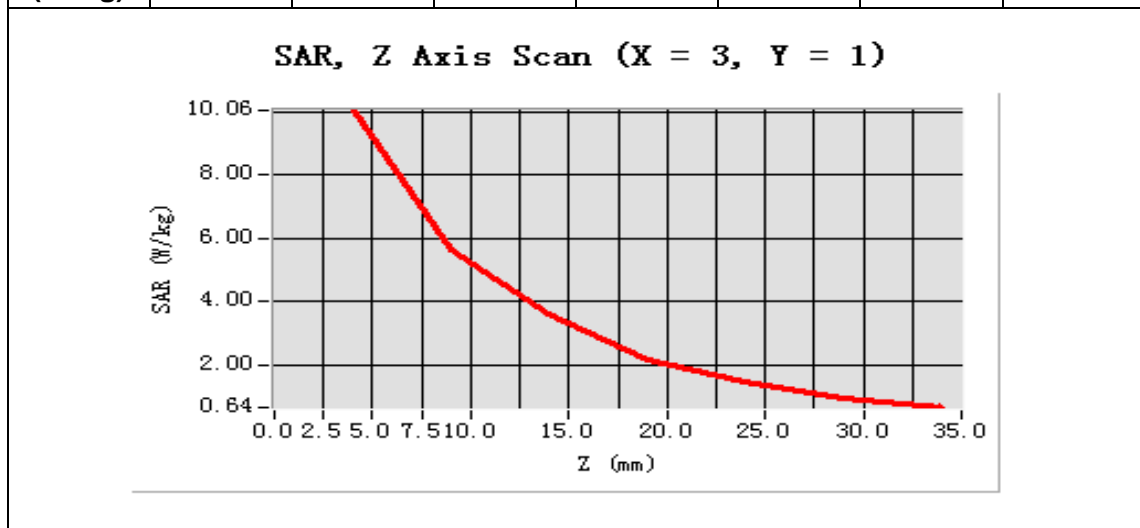



System Performance Check Data(2000MHz Head)

Type: Phone measurement (Complete)
 Area scan resolution: dx=8mm,dy=8mm
 Zoom scan resolution: dx=8mm, dy=8mm, dz=5mm
 Date of measurement: 2018.04.09
 Measurement duration: 13 minutes 27 seconds

A. Experimental conditions.

Phantom File	surf_sam_plan.txt
Phantom	Flat
Device Position	
Band	2000MHz
Channels	
Signal	CW

B. SAR Measurement Results

Band SAR

Frequency (MHz)	2000.000000
Relative permittivity (real part)	39.984477
Conductivity (S/m)	1.414283
Power drift (%)	-0.830000
Ambient Temperature:	22.1°C
Liquid Temperature:	22.4°C
ConvF:	5.61
Crest factor:	1:1

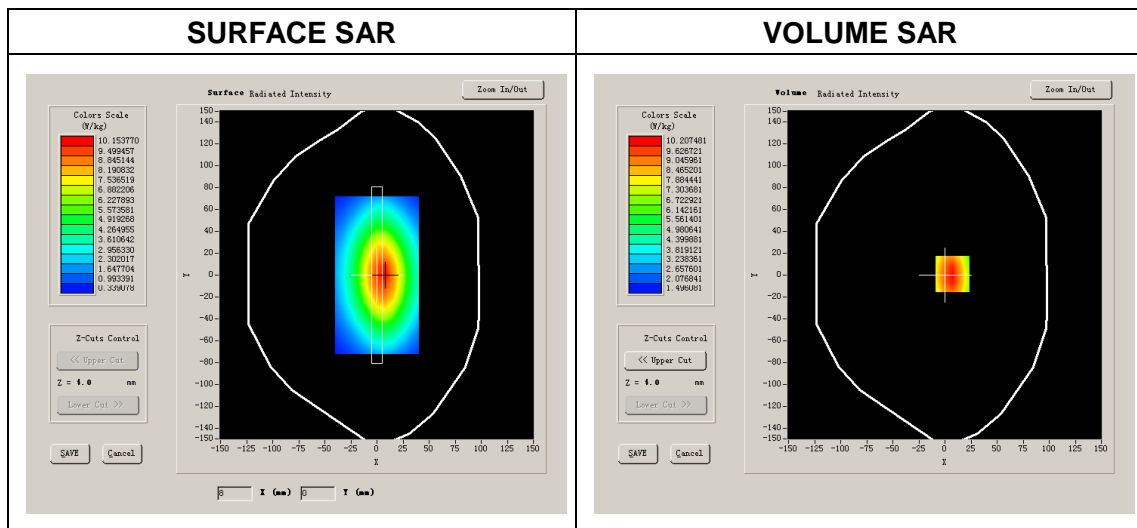

Maximum location: X=7.00, Y=1.00

SAR 10g (W/Kg)	1.992518
SAR 1g (W/Kg)	4.255954

Z Axis Scan

Z (mm)	0.00	4.00	9.00	14.00	19.00	24.00	29.00
SAR (W/Kg)	0.0000	10.2075	7.3996	5.4654	4.1101	3.1286	2.4128

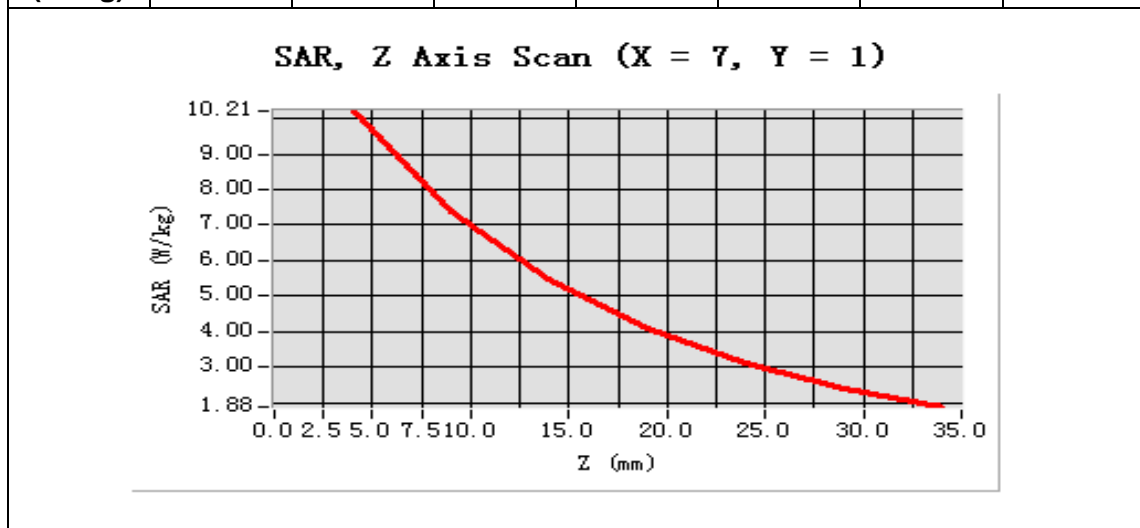



System Performance Check Data(2000MHz Body)

Type: Phone measurement (Complete)
 Area scan resolution: dx=8mm,dy=8mm
 Zoom scan resolution: dx=8mm, dy=8mm, dz=5mm
 Date of measurement: 2018.04.10
 Measurement duration: 13 minutes 27 seconds

A. Experimental conditions.

Phantom File	surf_sam_plan.txt
Phantom	Flat
Device Position	
Band	2000MHz
Channels	
Signal	CW

B. SAR Measurement Results

Band SAR

Frequency (MHz)	2000.000000
Relative permittivity (real part)	53.285167
Conductivity (S/m)	1.514073
Power drift (%)	-1.860000
Ambient Temperature:	22.1°C
Liquid Temperature:	22.4°C
ConvF:	5.71
Crest factor:	1:1

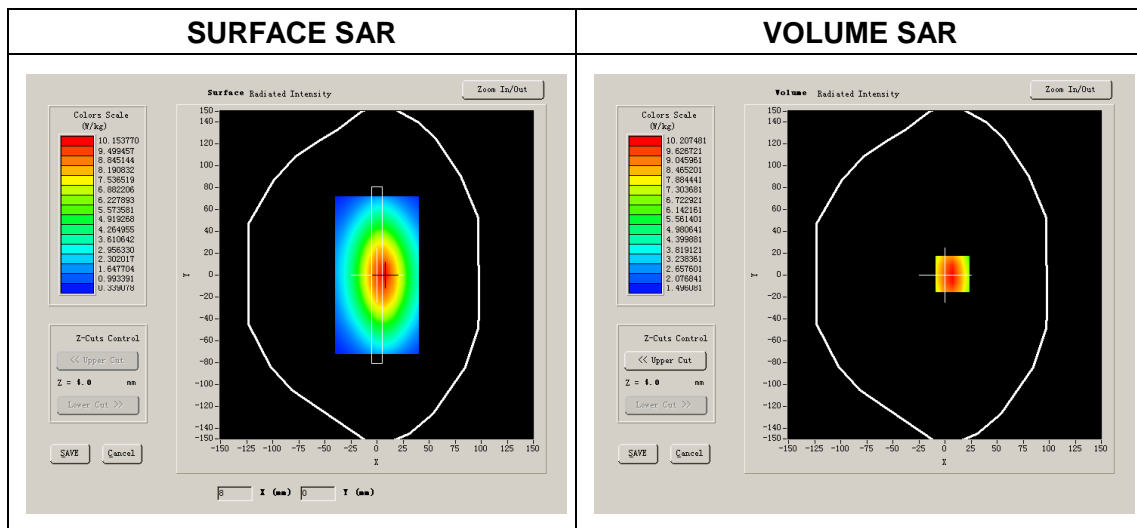

Maximum location: X=7.00, Y=1.00

SAR 10g (W/Kg)	2.092518
SAR 1g (W/Kg)	4.119540

Z Axis Scan

Z (mm)	0.00	4.00	9.00	14.00	19.00	24.00	29.00
SAR (W/Kg)	0.0000	10.2075	7.3996	5.4654	4.1101	3.1286	2.4128

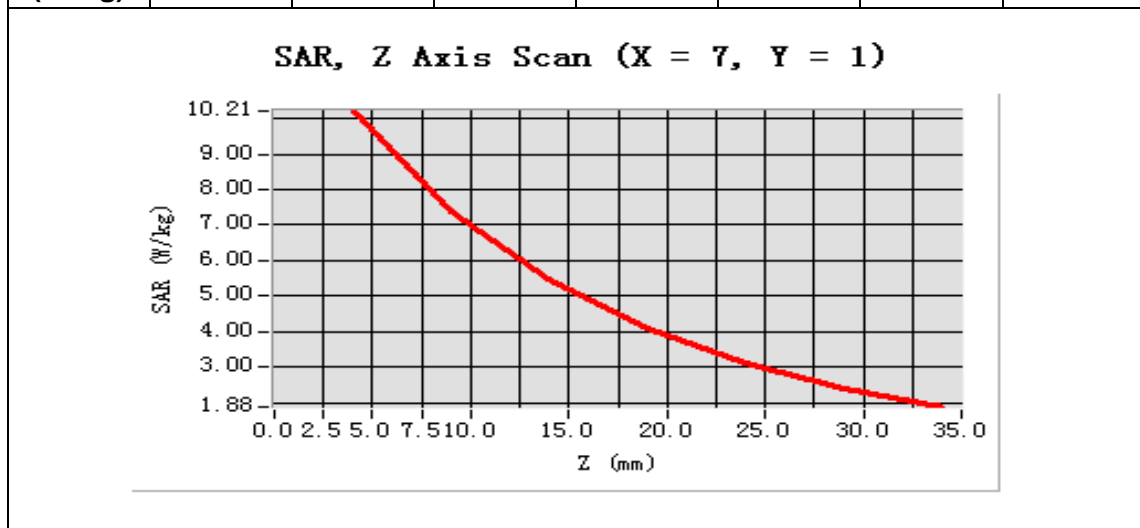



System Performance Check Data(2450MHz Head)

Type: Phone measurement (Complete)
 Area scan resolution: dx=8mm,dy=8mm
 Zoom scan resolution: dx=8mm, dy=8mm, dz=5mm
 Date of measurement: 2018.04.12
 Measurement duration: 13 minutes 31 seconds

A. Experimental conditions.

Phantom File	surf_sam_plan.txt
Phantom	Flat
Device Position	
Band	2450MHz
Channels	
Signal	CW

B. SAR Measurement Results

Band SAR

Frequency (MHz)	2450.000000
Relative permittivity (real part)	39.284446
Conductivity (S/m)	1.836061
Power Drift (%)	1.080000
Ambient Temperature:	22.0°C
Liquid Temperature:	21.8°C
ConvF:	4.74
Crest factor:	1:1

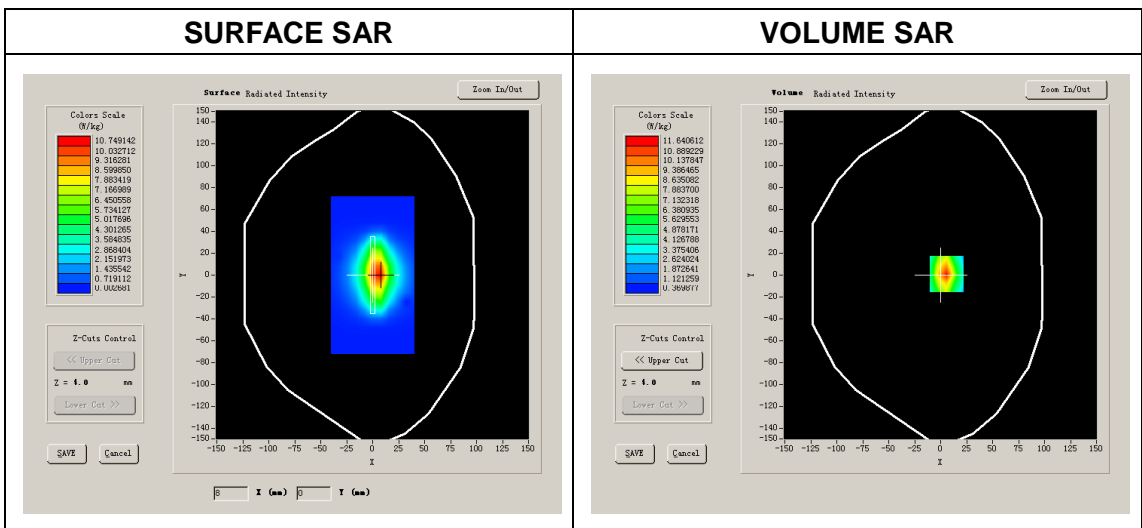

Maximum location: X=6.00, Y=1.00

SAR 10g (W/Kg)	2.377250
SAR 1g (W/Kg)	5.326074

Z Axis Scan

Z (mm)	0.00	4.00	9.00	14.00	19.00	24.00	29.00
SAR (W/Kg)	0.0000	12.9615	6.2096	3.8187	2.4504	1.5036	1.0219

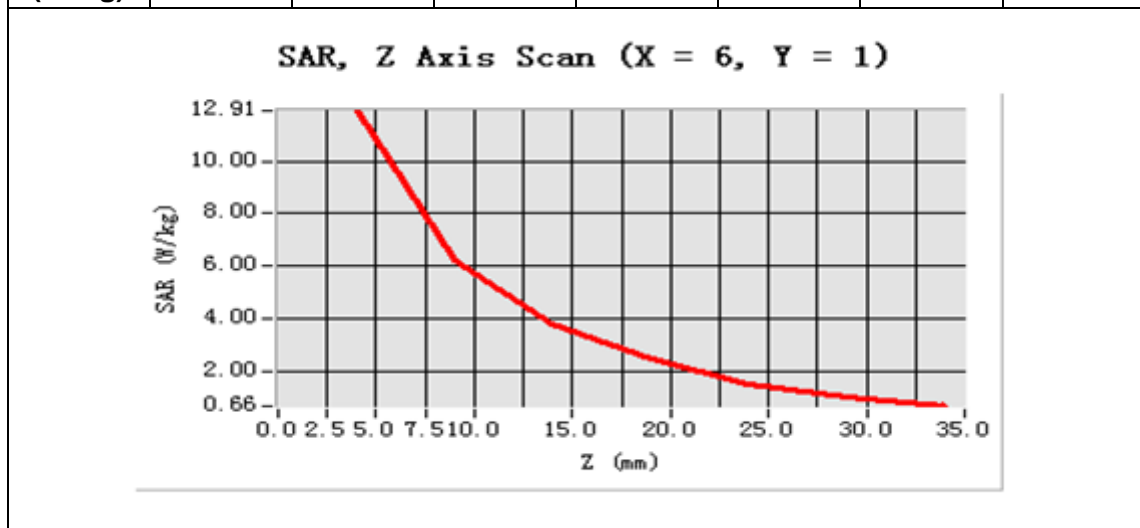

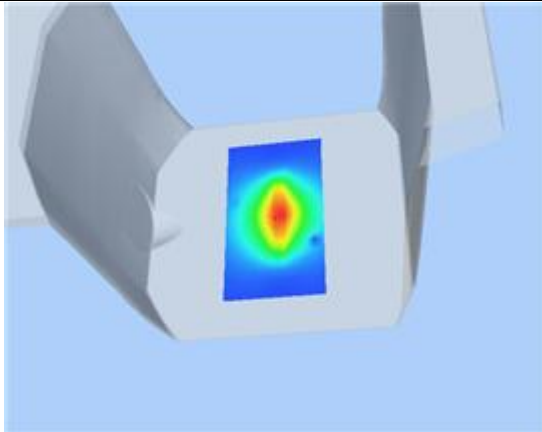
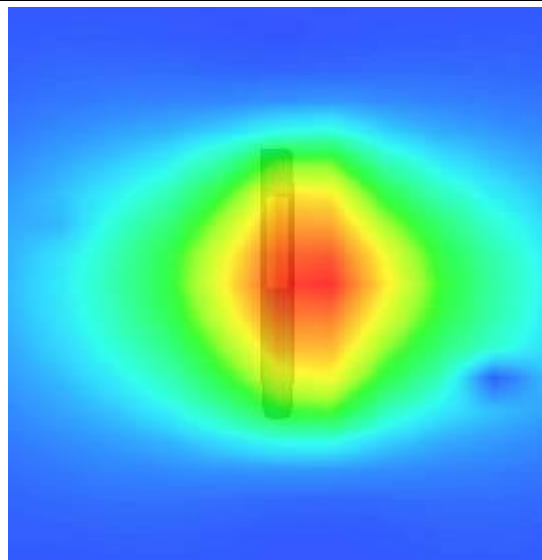
3D scen shot	Hot spot position
	



System Performance Check Data(2450MHz Body)

Type: Phone measurement (Complete)
 Area scan resolution: dx=8mm,dy=8mm
 Zoom scan resolution: dx=8mm, dy=8mm, dz=5mm
 Date of measurement: 2018.04.17
 Measurement duration: 13 minutes 31 seconds

A. Experimental conditions.

Phantom File	surf_sam_plan.txt
Phantom	Flat
Device Position	
Band	2450MHz
Channels	
Signal	CW

B. SAR Measurement Results

Band SAR

Frequency (MHz)	2450.000000
Relative permittivity (real part)	52.884446
Conductivity (S/m)	1.966143
Power Drift (%)	1.080000
Ambient Temperature:	22.0°C
Liquid Temperature:	21.8°C
ConvF:	4.93
Crest factor:	1:1

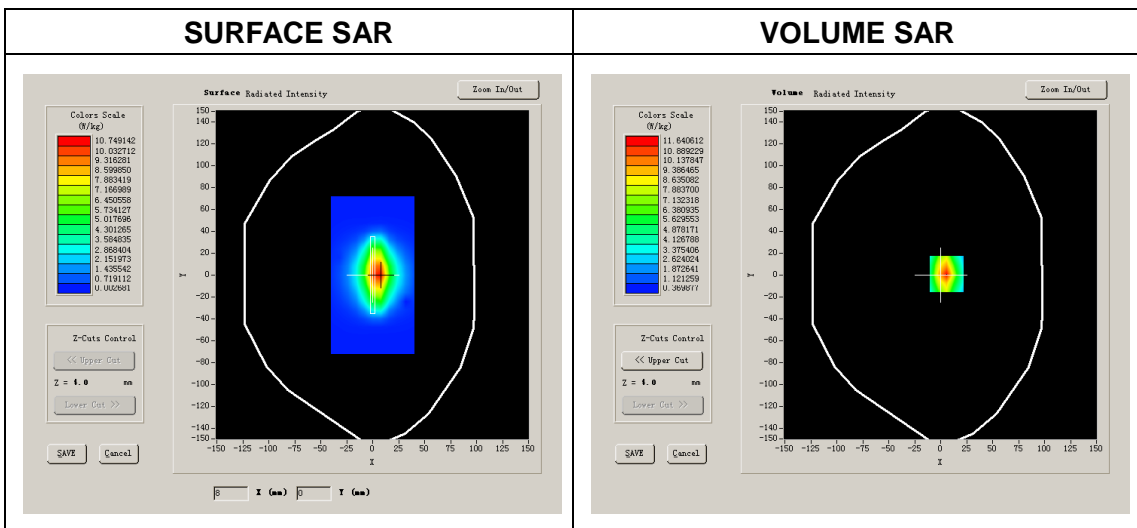

Maximum location: X=6.00, Y=1.00

SAR 10g (W/Kg)	2.377250
SAR 1g (W/Kg)	5.081074

Z Axis Scan

Z (mm)	0.00	4.00	9.00	14.00	19.00	24.00	29.00
SAR (W/Kg)	0.0000	12.9615	6.2096	3.8187	2.4504	1.5036	1.0219

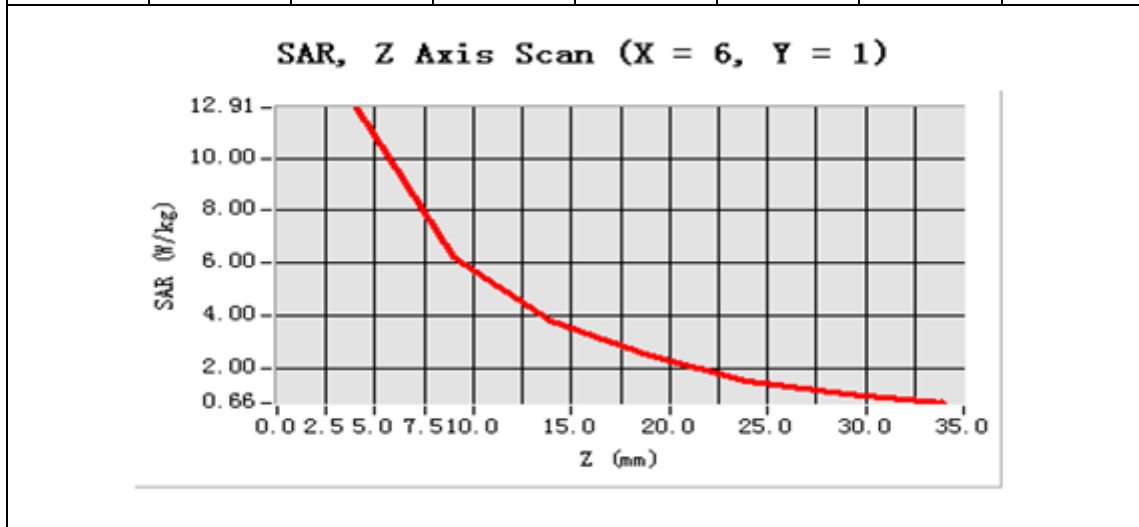

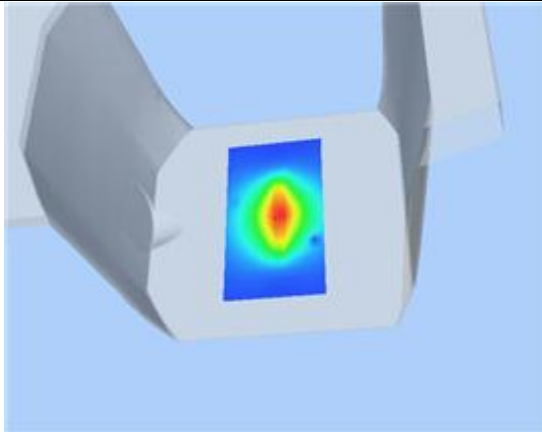
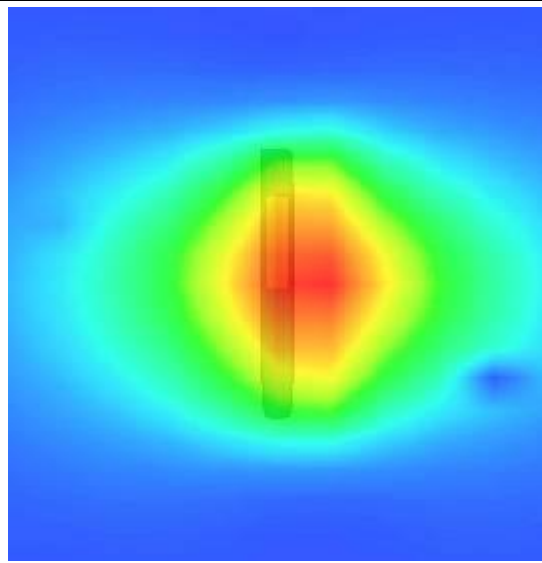
3D scen shot	Hot spot position
	

**System Performance Check Data(5200MHz Head)**

Type: Phone measurement (Complete)

Area scan resolution: dx=8mm,dy=8mm

Zoom scan resolution: dx=4mm, dy=4mm, dz=2mm

Date of measurement: 2018.04.13

Measurement duration: 23 minutes 27 seconds

A. Experimental conditions.

Phantom File	surf_sam_plan.txt
Phantom	Validation plane
Device Position	
Band	5200MHz
Channels	
Signal	CW

B. SAR Measurement Results**Band SAR**

Frequency (MHz)	5200.000000
Relative permittivity (real part)	36.123014
Conductivity (S/m)	4.665260
Power Drift (%)	2.310000
Ambient Temperature:	22.9°C
Liquid Temperature:	22.1°C
ConvF:	21.61
Crest factor:	1:1

SURFACE SAR	VOLUME SAR
--------------------	-------------------

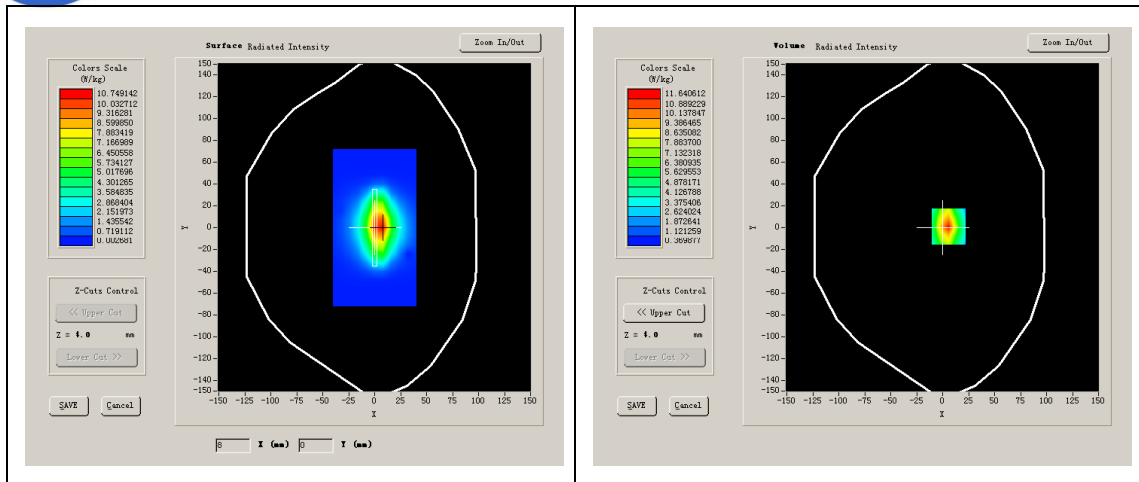

Maximum location: X=1.00, Y=3.00

SAR 10g (W/Kg)	5.651263
SAR 1g (W/Kg)	16.398864

Z Axis Scan

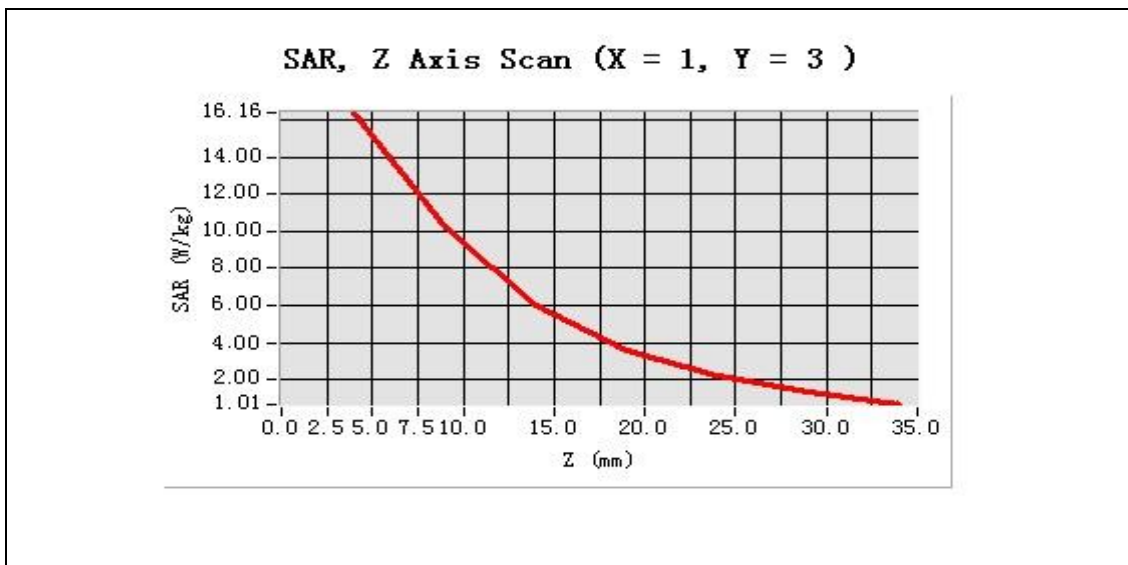

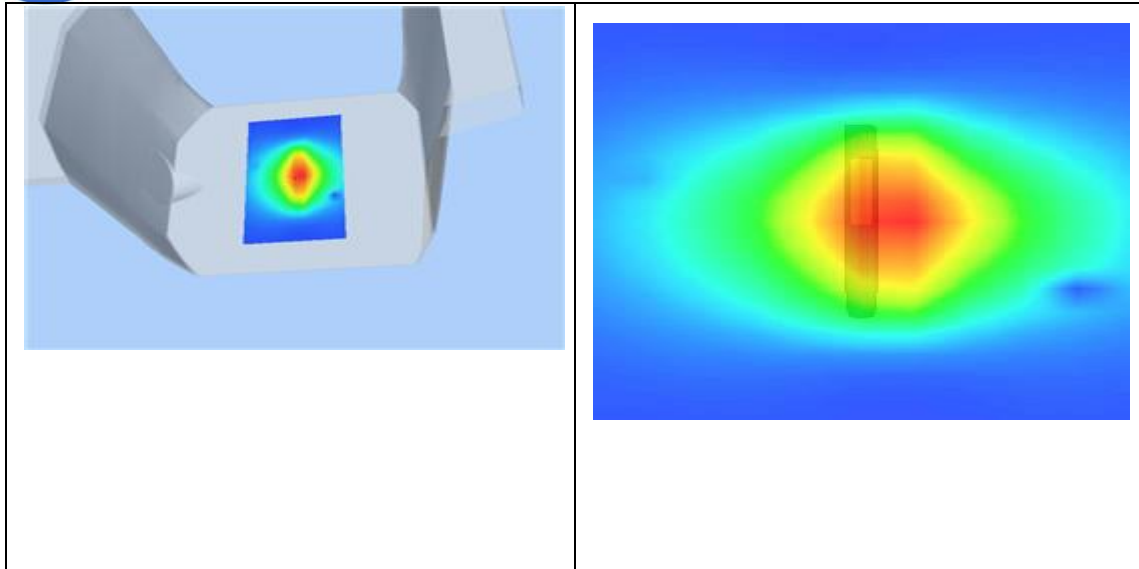

System Performance Check Data(5600MHz Head)
--

Type: Phone measurement (Complete)

Area scan resolution: dx=8mm,dy=8mm

Zoom scan resolution: dx=4mm, dy=4mm, dz=2mm

Date of measurement: 2018.04.13

Measurement duration: 13 minutes 27 seconds

A. Experimental conditions.

Phantom File	surf_sam_plan.txt
Phantom	Validation plane
Device Position	
Band	5600MHz
Channels	
Signal	CW

B. SAR Measurement Results

Band SAR

Frequency (MHz)	5600.000000
Relative permittivity (real part)	35.562139
Conductivity (S/m)	5.100255



Power Drift (%)	1.080000
Ambient Temperature:	22.9°C
Liquid Temperature:	22.1°C
ConvF:	22.92
Crest factor:	1:1

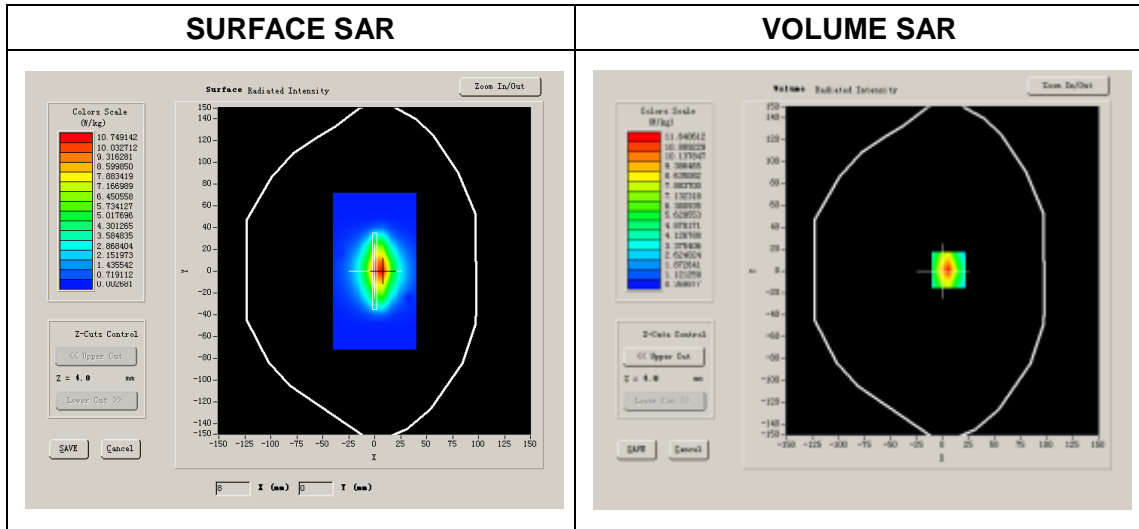

Maximum location: X=-1.00, Y=-5.00

SAR 10g (W/Kg)	6.0553669
SAR 1g (W/Kg)	17.144263

Z Axis Scan

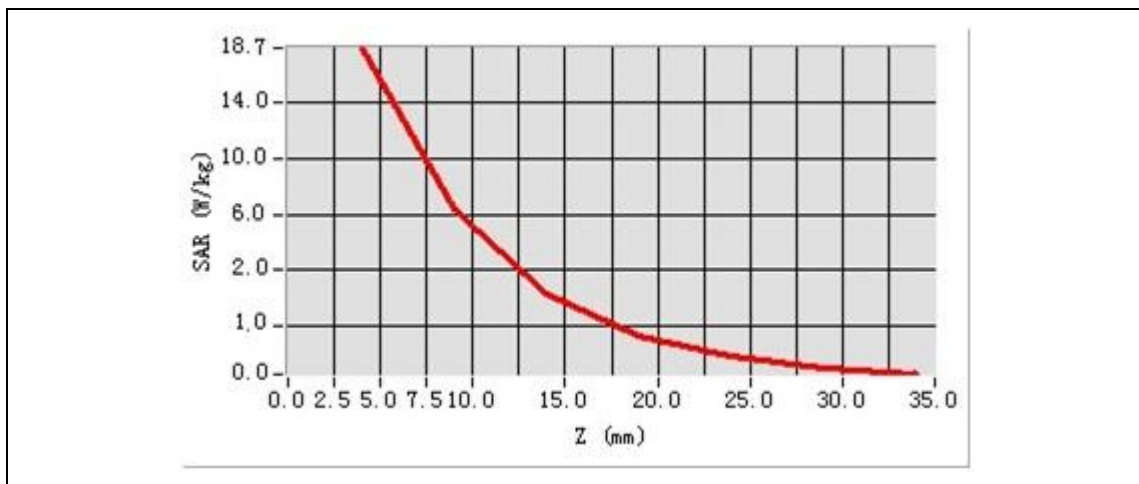

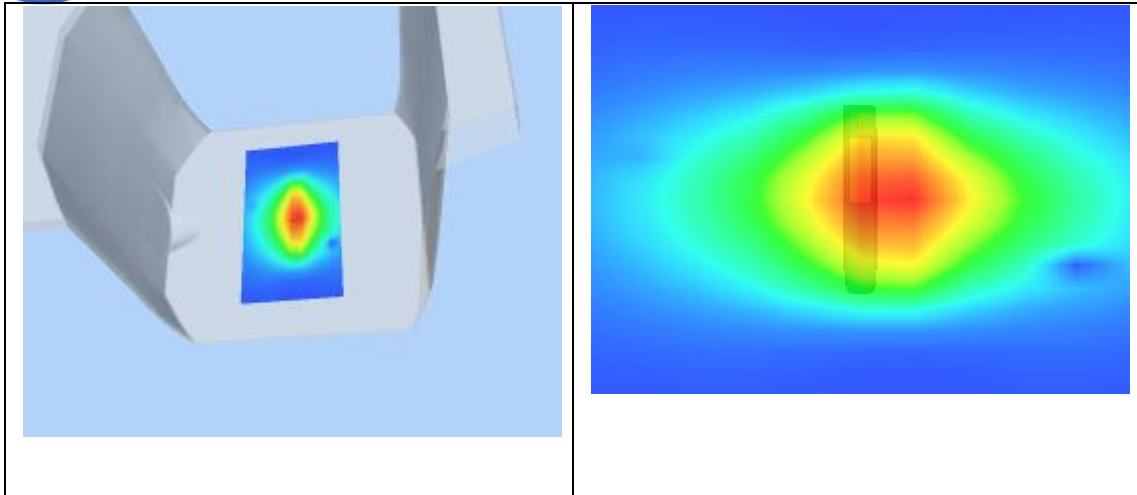

System Performance Check Data(5800MHz Head)

Type: Phone measurement (Complete)

Area scan resolution: dx=8mm,dy=8mm

Zoom scan resolution: dx=4mm, dy=4mm, dz=2mm

Date of measurement: 2018.04.13

Measurement duration: 13 minutes 27 seconds

A. Experimental conditions.

Phantom File	surf_sam_plan.txt
Phantom	Validation plane
Device Position	
Band	5800MHz
Channels	
Signal	CW

B. SAR Measurement Results

Band SAR

Frequency (MHz)	5800.000000
Relative permittivity (real part)	35.334675



Conductivity (S/m)	5.310226
Power Drift (%)	1.260000
Ambient Temperature:	22.9°C
Liquid Temperature:	22.1°C
ConvF:	22.42
Crest factor:	1:1

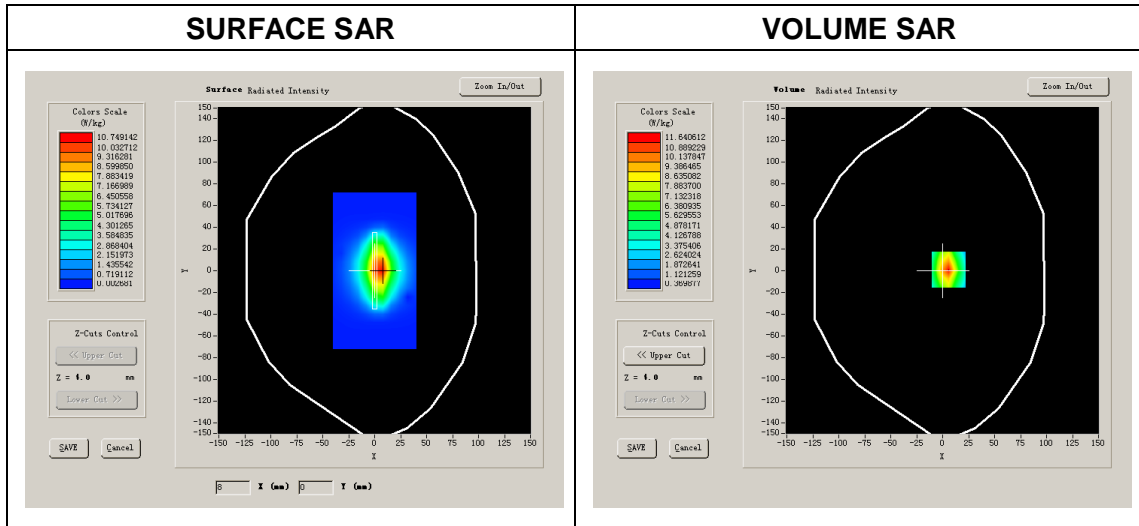

Maximum location: X=-6.00, Y=-1.00

SAR 10g (W/Kg)	5.994412
SAR 1g (W/Kg)	17.711256

Z Axis Scan

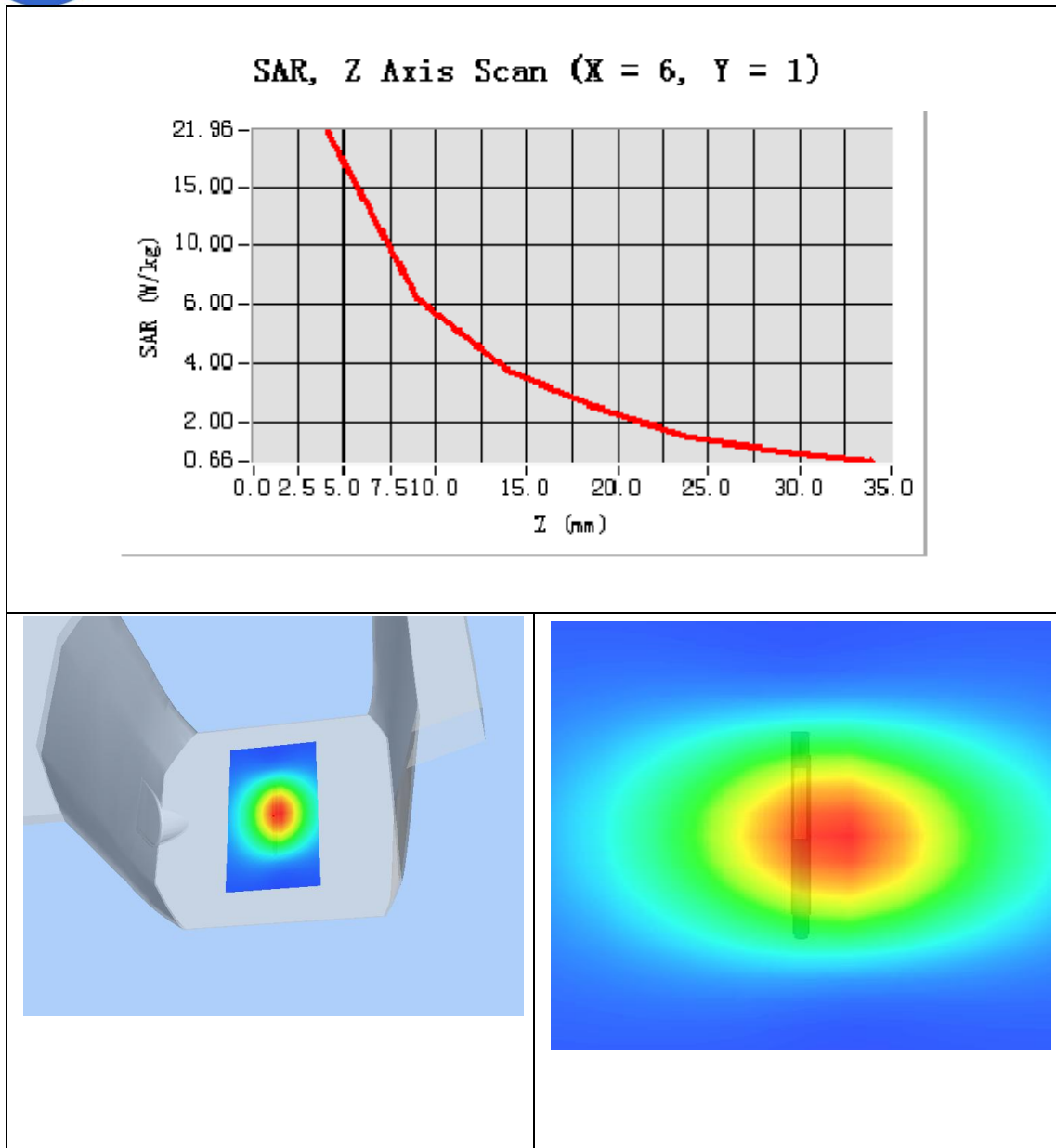

System Performance Check Data(5200MHz Body)

Type: Phone measurement (Complete)

Area scan resolution: dx=8mm,dy=8mm

Zoom scan resolution: dx=4mm, dy=4mm, dz=2mm

Date of measurement: 2018.04.16

Measurement duration: 23 minutes 27 seconds

A. Experimental conditions.



Phantom File	surf_sam_plan.txt
Phantom	Validation plane
Device Position	
Band	5200MHz
Channels	
Signal	CW

B. SAR Measurement Results

Band SAR

Frequency (MHz)	5200.000000
Relative permittivity (real part)	48.273014
Conductivity (S/m)	5.443260
Power Drift (%)	2.310000
Ambient Temperature:	22.9°C
Liquid Temperature:	22.1°C
ConvF:	22.11
Crest factor:	1:1

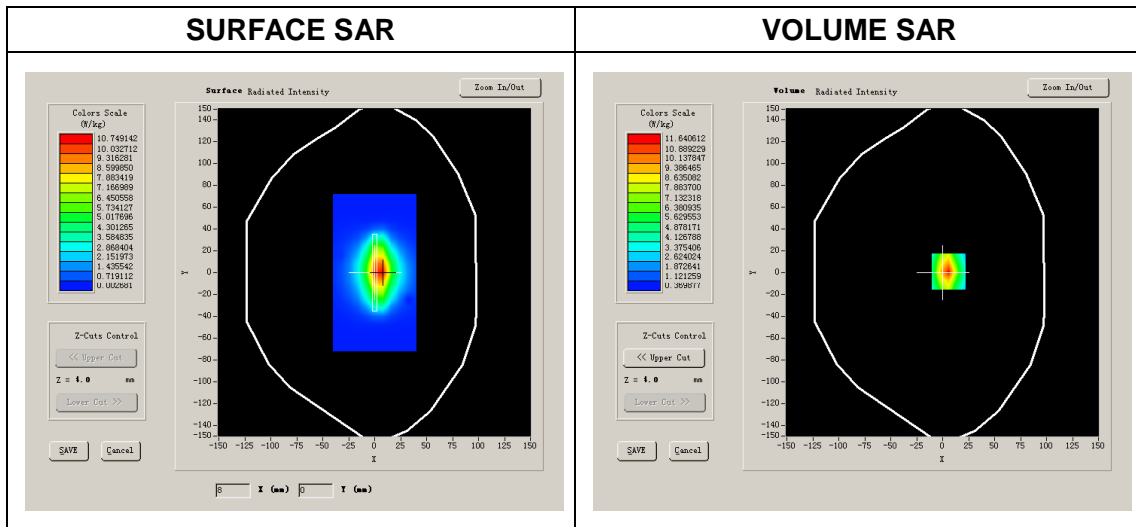

Maximum location: X=1.00, Y=3.00

SAR 10g (W/Kg)	5.624355
SAR 1g (W/Kg)	16.28442

Z Axis Scan

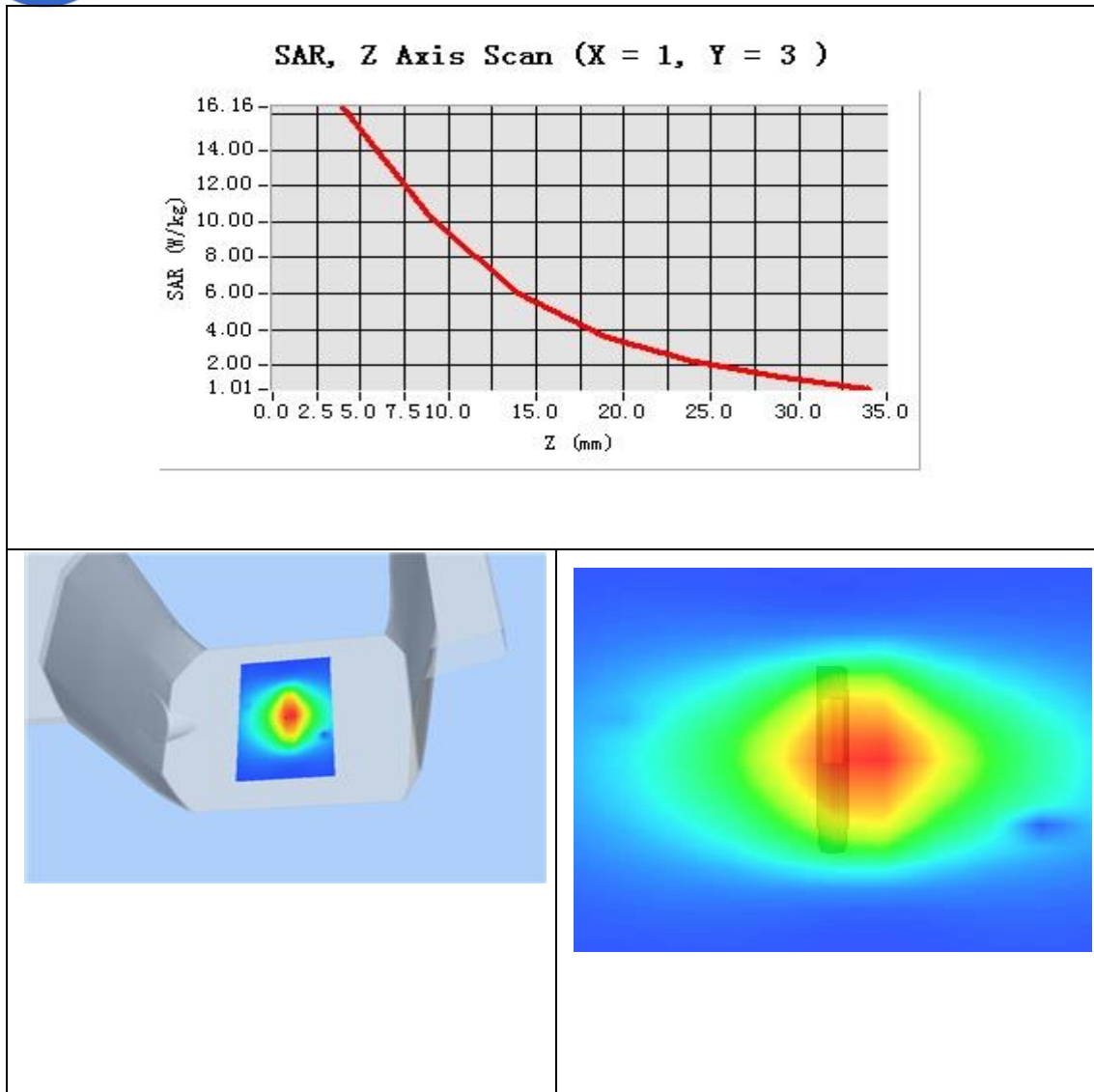

System Performance Check Data(5600MHz Body)

Type: Phone measurement (Complete)

Area scan resolution: dx=8mm,dy=8mm

Zoom scan resolution: dx=4mm, dy=4mm, dz=2mm

Date of measurement: 2018.04.16

Measurement duration: 13 minutes 27 seconds

A. Experimental conditions.



Phantom File	surf_sam_plan.txt
Phantom	Validation plane
Device Position	
Band	5600MHz
Channels	
Signal	CW

B. SAR Measurement Results

Band SAR

Frequency (MHz)	5600.000000
Relative permittivity (real part)	48.394381
Conductivity (S/m)	5.7432600
Power Drift (%)	1.080000
Ambient Temperature:	22.9°C
Liquid Temperature:	22.1°C
ConvF:	23.69
Crest factor:	1:1

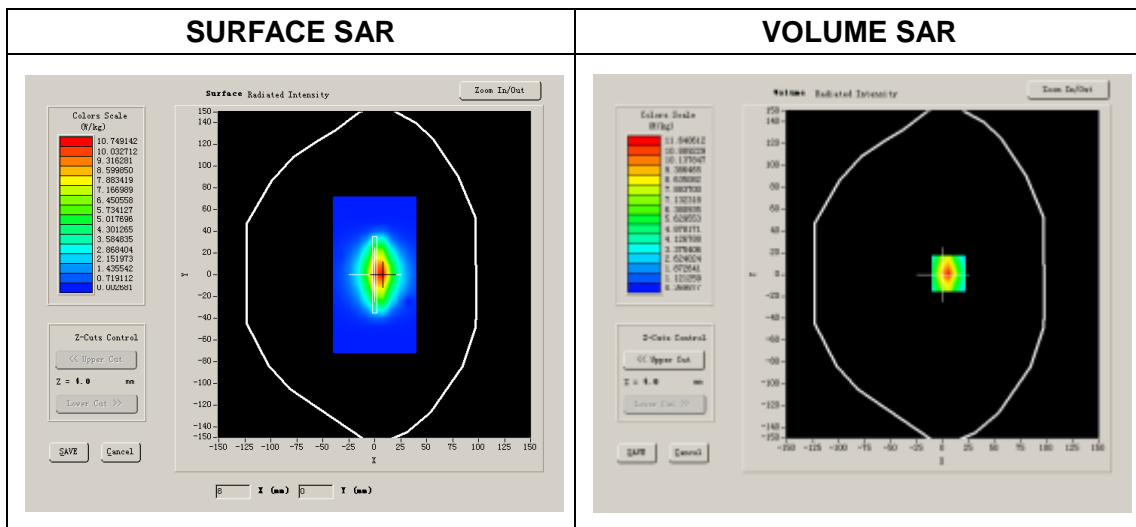

Maximum location: X=-1.00, Y=-5.00

SAR 10g (W/Kg)	5.906961
SAR 1g (W/Kg)	17.19624

Z Axis Scan

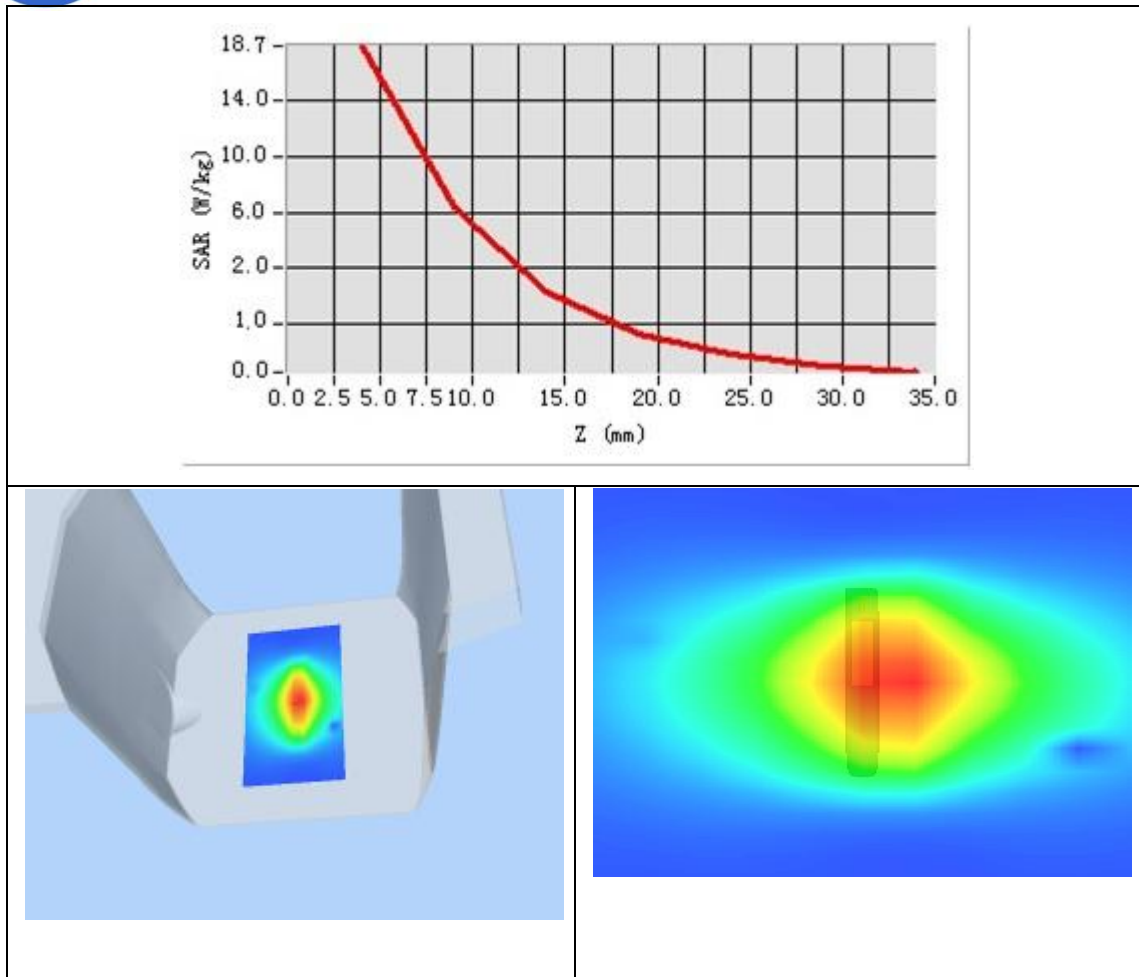

System Performance Check Data(5800MHz Body)

Type: Phone measurement (Complete)
 Area scan resolution: dx=8mm,dy=8mm
 Zoom scan resolution: dx=4mm, dy=4mm, dz=2mm
 Date of measurement: 2018.04.16
 Measurement duration: 23 minutes 27 seconds

A. Experimental conditions.



Phantom File	surf_sam_plan.txt
Phantom	Validation plane
Device Position	
Band	5800MHz
Channels	
Signal	CW

B. SAR Measurement Results

Band SAR

Frequency (MHz)	5800.000000
Relative permittivity (real part)	48.093428
Conductivity (S/m)	5.930716
Power Drift (%)	1.260000
Ambient Temperature:	22.9°C
Liquid Temperature:	22.1°C
ConvF:	23.02
Crest factor:	1:1

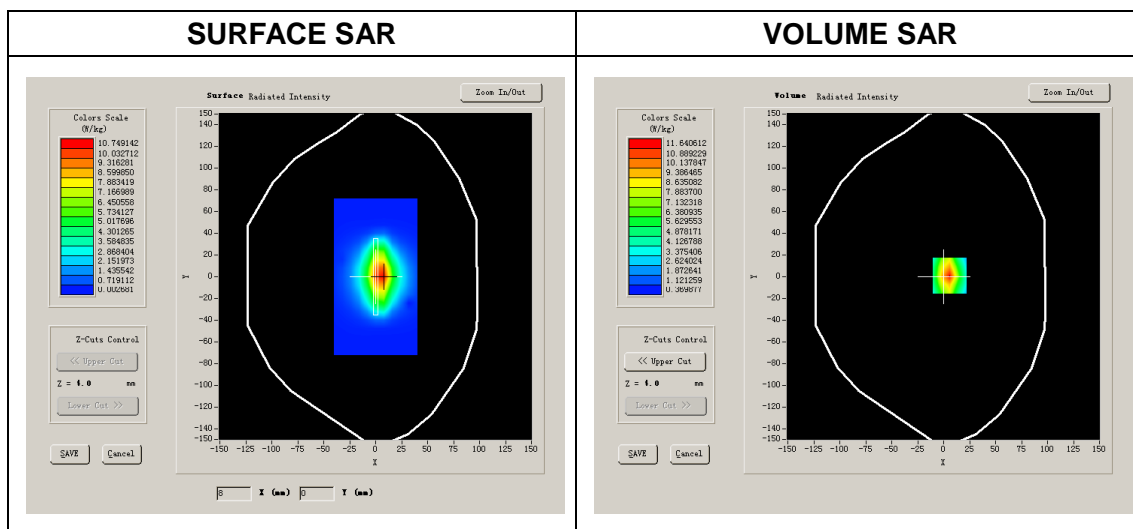

Maximum location: X=-6.00, Y=-1.00

SAR 10g (W/Kg)	5.982634
SAR 1g (W/Kg)	17.695290

Z Axis Scan

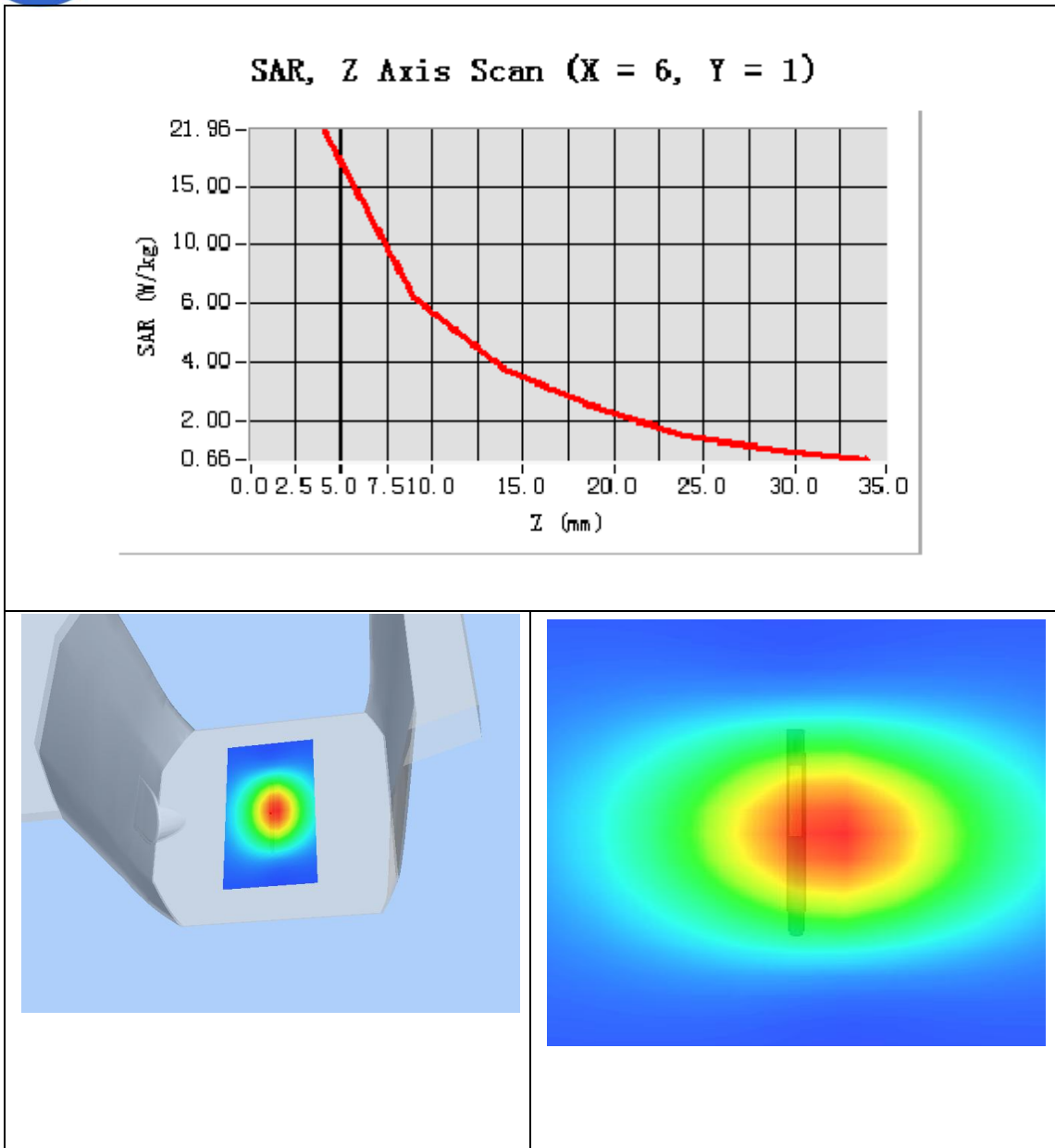

Annex D Plots of Maximum SAR Test Results

MEASUREMENT 1

Type: Phone measurement (Complete)
 Area scan resolution: dx=15mm,dy=15mm
 Zoom scan resolution: dx=8mm, dy=8mm, dz=5mm
 Date of measurement: 2018.04.12
 Measurement duration: 16 minutes 36 seconds

A. Experimental conditions.

<u>Phantom File</u>	surf_sam_plan.txt
<u>Phantom</u>	Left head
<u>Device Position</u>	Cheek
<u>Band</u>	CUSTOM (GPRS850_4Tx)
<u>Channels</u>	Middle
<u>Signal</u>	GPRS

B. SAR Measurement Results

Middle Band SAR (Channel 190):

Frequency (MHz)	836.599976
Relative permittivity (real part)	41.179600
Conductivity (S/m)	0.901269
Power drift (%)	0.520000
Ambient Temperature:	22.6°C
Liquid Temperature:	21.2°C
ConvF:	6.13
Crest factor:	1:2.08

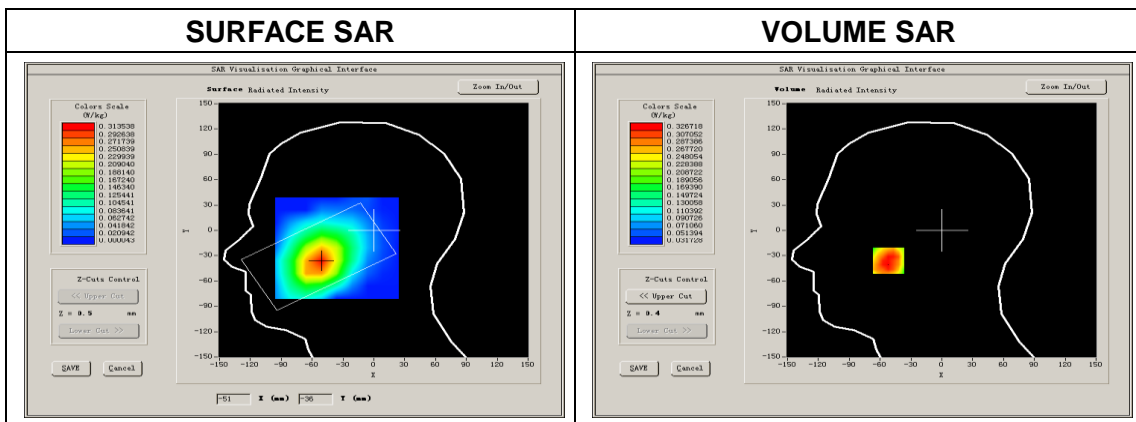

NOTE: This document is issued by MORLAB, the test report shall not be reproduced except in full without prior written permission of the company. The test results apply only to the particular sample(s) tested and to the specific tests carried out which is available on request for validation and information confirmed at our website.

Maximum location: X=-52.00, Y=-36.00

SAR Peak: 0.43W/kg

SAR 10g (W/Kg)	0.223305
SAR 1g (W/Kg)	0.310305

Z (mm)	0.00	4.00	9.00	14.00	19.00	24.00	29.00
SAR (W/Kg)	0.3913	0.3267	0.2542	0.1977	0.1482	0.1126	0.0839

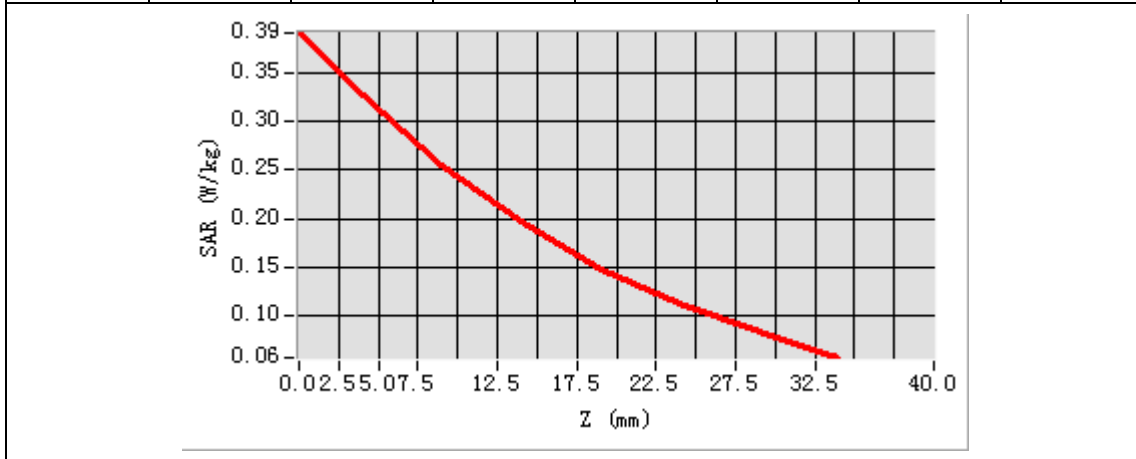

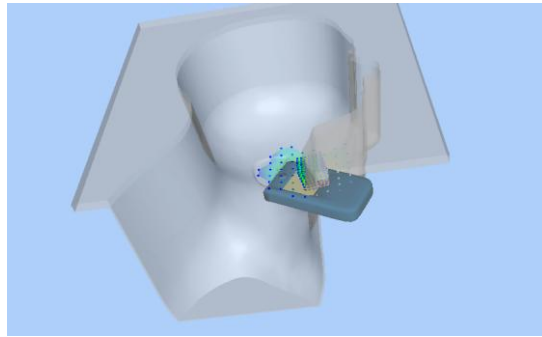
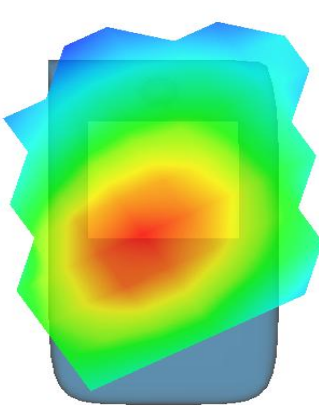
<p>3D screen shot</p>	<p>Hot spot position</p>
	

NOTE: This document is issued by MORLAB, the test report shall not be reproduced except in full without prior written permission of the company. The test results apply only to the particular sample(s) tested and to the specific tests carried out which is available on request for validation and information confirmed at our website.

MEASUREMENT 2

Type: Phone measurement (Complete)

Area scan resolution: dx=15mm,dy=15mm

Zoom scan resolution: dx=8mm, dy=8mm, dz=5mm

Date of measurement: 2018.04.09

Measurement duration: 16 minutes 28 seconds

A. Experimental conditions.

<u>Phantom File</u>	<u>surf_sam_plan.txt</u>
<u>Phantom</u>	<u>Right head</u>
<u>Device Position</u>	<u>Cheek</u>
<u>Band</u>	<u>CUSTOM (GPRS1900 4Tx)</u>
<u>Channels</u>	<u>Low</u>
<u>Signal</u>	<u>GPRS</u>

B. SAR Measurement Results

Lower Band SAR (Channel 512):

Frequency (MHz)	1850.199951
Relative permittivity (real part)	40.321000
Conductivity (S/m)	1.390860
Power drift (%)	4.520000
Ambient Temperature:	22.1°C
Liquid Temperature:	22.4°C
ConvF:	5.61
Duty cycle:	1:2.08

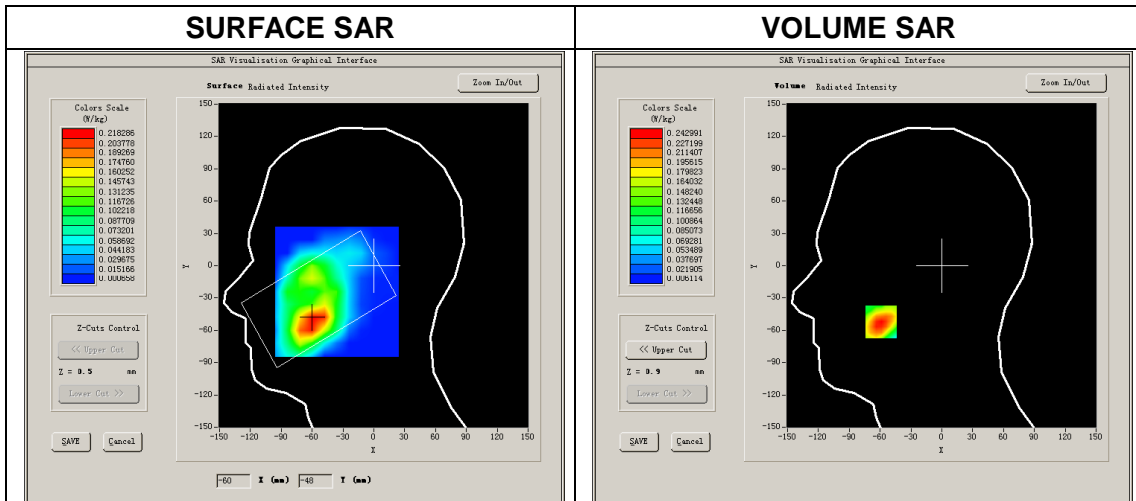

NOTE: This document is issued by MORLAB, the test report shall not be reproduced except in full without prior written permission of the company. The test results apply only to the particular sample(s) tested and to the specific tests carried out which is available on request for validation and information confirmed at our website.

Maximum location: X=-59.00, Y=-52.00

SAR Peak: 0.36W/kg

SAR 10g (W/Kg)	0.132330
SAR 1g (W/Kg)	0.228494

Z (mm)	0.00	4.00	9.00	14.00	19.00	24.00	29.00
SAR (W/Kg)	0.3609	0.2430	0.1516	0.0901	0.0618	0.0410	0.0214

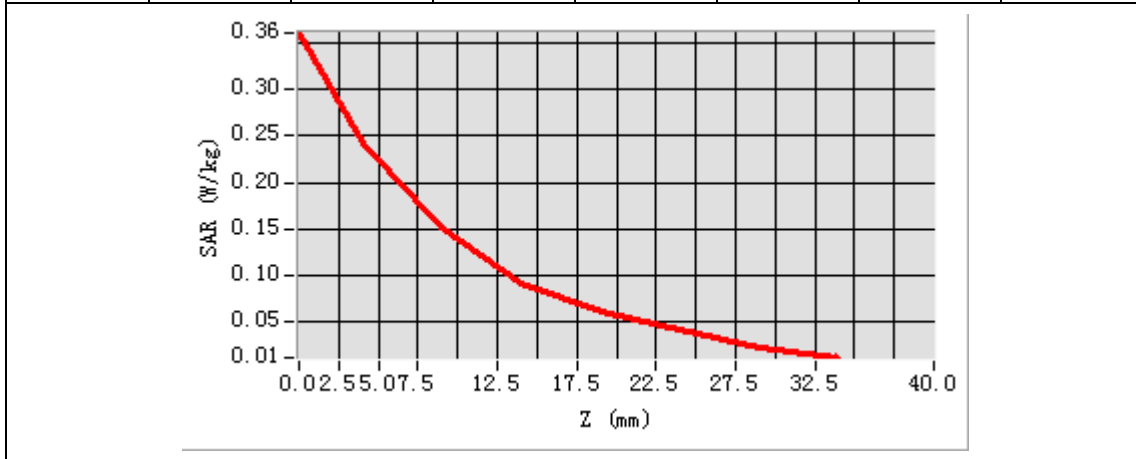

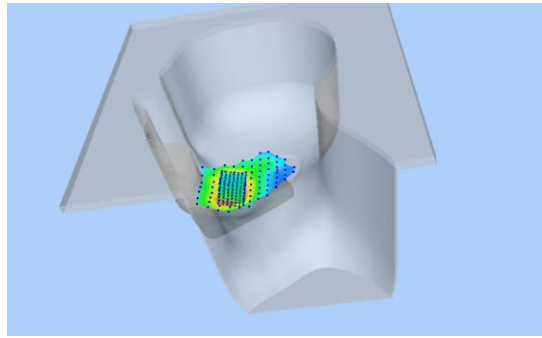
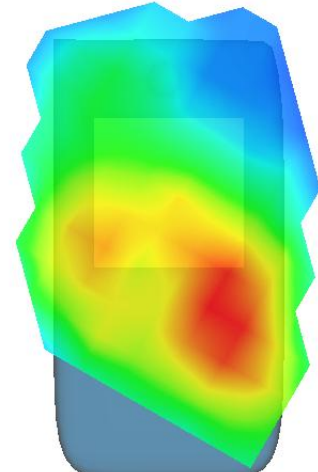
3D screen shot	Hot spot position
	

NOTE: This document is issued by MORLAB, the test report shall not be reproduced except in full without prior written permission of the company. The test results apply only to the particular sample(s) tested and to the specific tests carried out which is available on request for validation and information confirmed at our website.

MEASUREMENT 3

Type: Phone measurement (Complete)

Area scan resolution: dx=15mm,dy=15mm

Zoom scan resolution: dx=8mm, dy=8mm, dz=5mm

Date of measurement: 2018.04.09

Measurement duration: 16 minutes 18 seconds

A. Experimental conditions.

Phantom File	surf_sam_plan.txt
Phantom	Left head
Device Position	Cheek
Band	Band2_WCDMA1900
Channels	Low
Signal	RMC

B. SAR Measurement Results

Lower Band SAR (Channel 9262):

Frequency (MHz)	1852.400024
Relative permittivity (real part)	40.300000
Conductivity (S/m)	1.370851
Power drift (%)	-1.600000
Ambient Temperature:	22.1°C
Liquid Temperature:	22.4°C
ConvF:	5.61
Duty cycle:	1:1

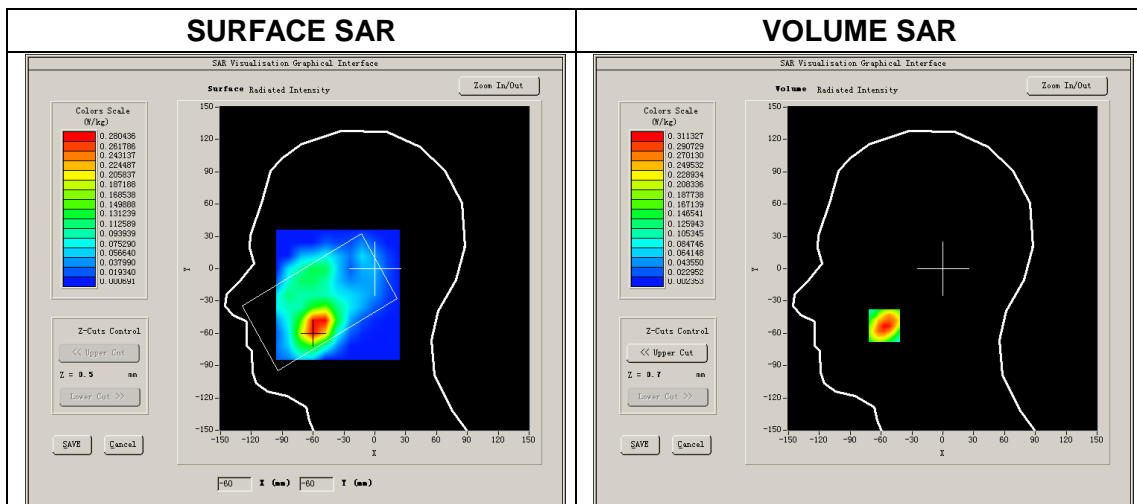

NOTE: This document is issued by MORLAB, the test report shall not be reproduced except in full without prior written permission of the company. The test results apply only to the particular sample(s) tested and to the specific tests carried out which is available on request for validation and information confirmed at our website.

Maximum location: X=-57.00, Y=-53.00

SAR Peak: 0.46W/kg

SAR 10g (W/Kg)	0.162291
SAR 1g (W/Kg)	0.283864

Z (mm)	0.00	4.00	9.00	14.00	19.00	24.00	29.00
SAR (W/Kg)	0.4595	0.3113	0.1878	0.1327	0.0761	0.0436	0.0274

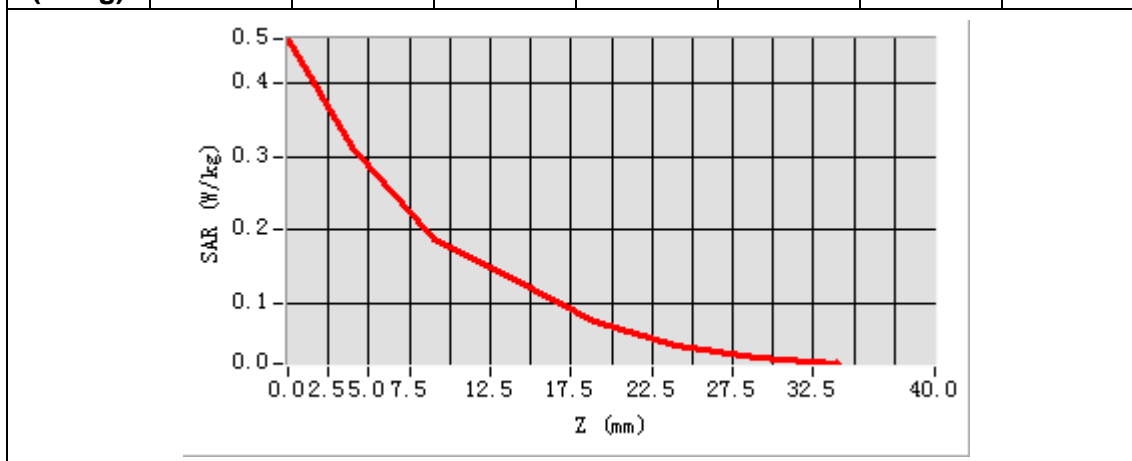

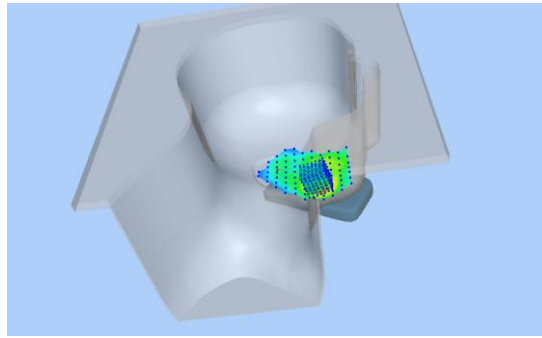
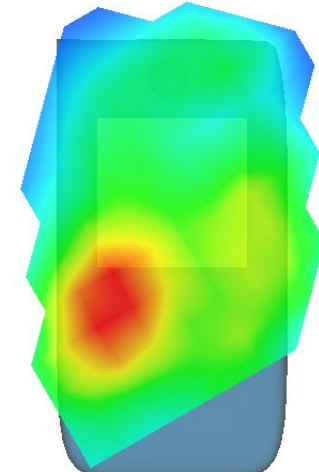
3D screen shot	Hot spot position
	

NOTE: This document is issued by MORLAB, the test report shall not be reproduced except in full without prior written permission of the company. The test results apply only to the particular sample(s) tested and to the specific tests carried out which is available on request for validation and information confirmed at our website.

MEASUREMENT 4

Type: Phone measurement (Complete)

Area scan resolution: dx=15mm,dy=15mm

Zoom scan resolution: dx=8mm, dy=8mm, dz=5mm

Date of measurement: 2018.04.09

Measurement duration: 16 minutes 23 seconds

A. Experimental conditions.

<u>Phantom File</u>	<u>surf_sam_plan.txt</u>
<u>Phantom</u>	<u>Right head</u>
<u>Device Position</u>	<u>Cheek</u>
<u>Band</u>	<u>Band4 WCDMA1700</u>
<u>Channels</u>	<u>Low</u>
<u>Signal</u>	<u>RMC</u>

B. SAR Measurement Results

Lower Band SAR (Channel 1312):

Frequency (MHz)	1712.000000
Relative permittivity (real part)	40.234588
Conductivity (S/m)	1.249644
Power drift (%)	-2.890000
Ambient Temperature:	22.3C
Liquid Temperature:	22.6C
ConvF:	5.21
Crest factor:	1:1

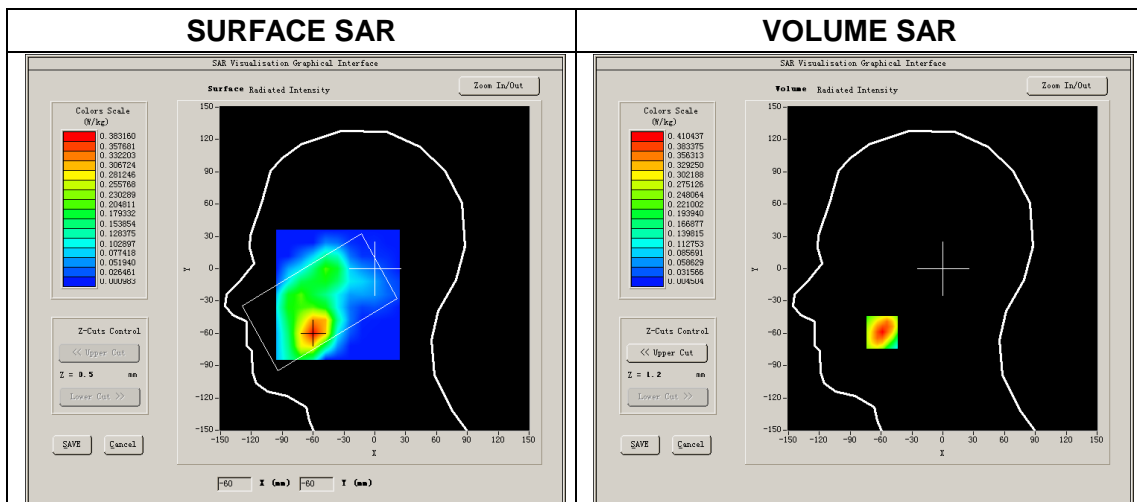

NOTE: This document is issued by MORLAB, the test report shall not be reproduced except in full without prior written permission of the company. The test results apply only to the particular sample(s) tested and to the specific tests carried out which is available on request for validation and information confirmed at our website.

Maximum location: X=-59.00, Y=-59.00

SAR Peak: 0.60W/kg

SAR 10g (W/Kg)	0.227504
SAR 1g (W/Kg)	0.375201

Z (mm)	0.00	4.00	9.00	14.00	19.00	24.00	29.00
SAR (W/Kg)	0.6064	0.4104	0.2529	0.1750	0.1106	0.0753	0.0469

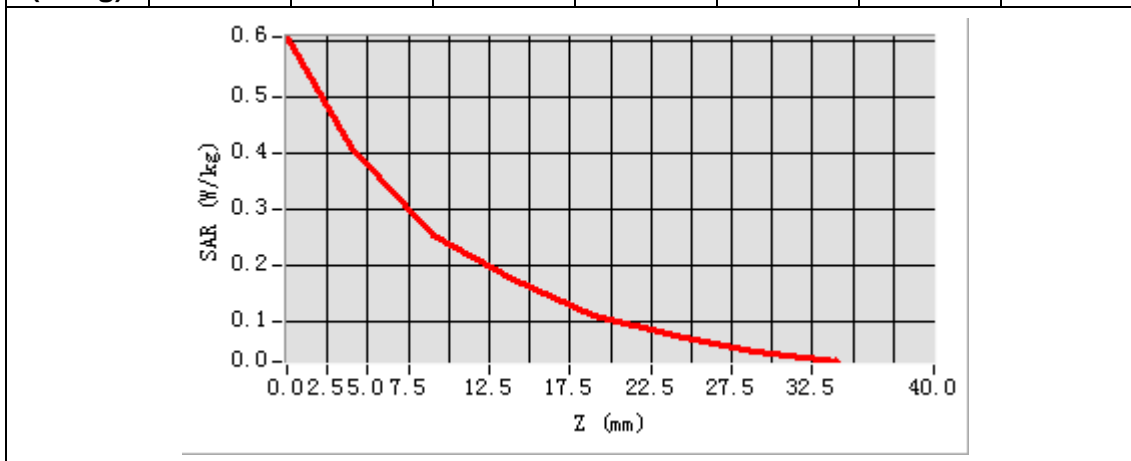

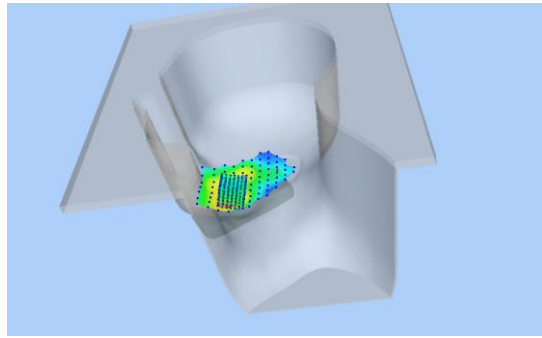
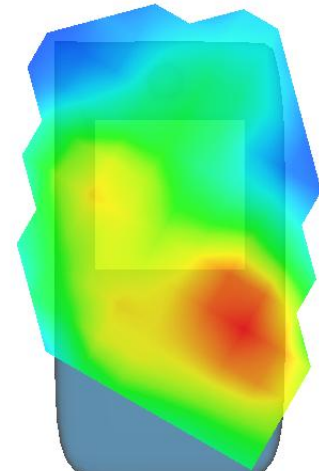
<p>3D screen shot</p>	<p>Hot spot position</p>
	

NOTE: This document is issued by MORLAB, the test report shall not be reproduced except in full without prior written permission of the company. The test results apply only to the particular sample(s) tested and to the specific tests carried out which is available on request for validation and information confirmed at our website.

MEASUREMENT 5

Type: Phone measurement (Complete)

Area scan resolution: dx=15mm,dy=15mm

Zoom scan resolution: dx=8mm, dy=8mm, dz=5mm

Date of measurement: 2018.04.12

Measurement duration: 16 minutes 28 seconds

A. Experimental conditions.

<u>Phantom File</u>	<u>surf_sam_plan.txt</u>
<u>Phantom</u>	<u>Left head</u>
<u>Device Position</u>	<u>Cheek</u>
<u>Band</u>	<u>Band5_WCDMA850</u>
<u>Channels</u>	<u>Middle</u>
<u>Signal</u>	<u>RMC</u>

B. SAR Measurement Results

Middle Band SAR (Channel 4182):

Frequency (MHz)	836.400024
Relative permittivity (real part)	41.53528
Conductivity (S/m)	0.901453
Power drift (%)	3.880000
Ambient Temperature:	22.6°C
Liquid Temperature:	21.2°C
ConvF:	6.13
Crest factor:	1:1

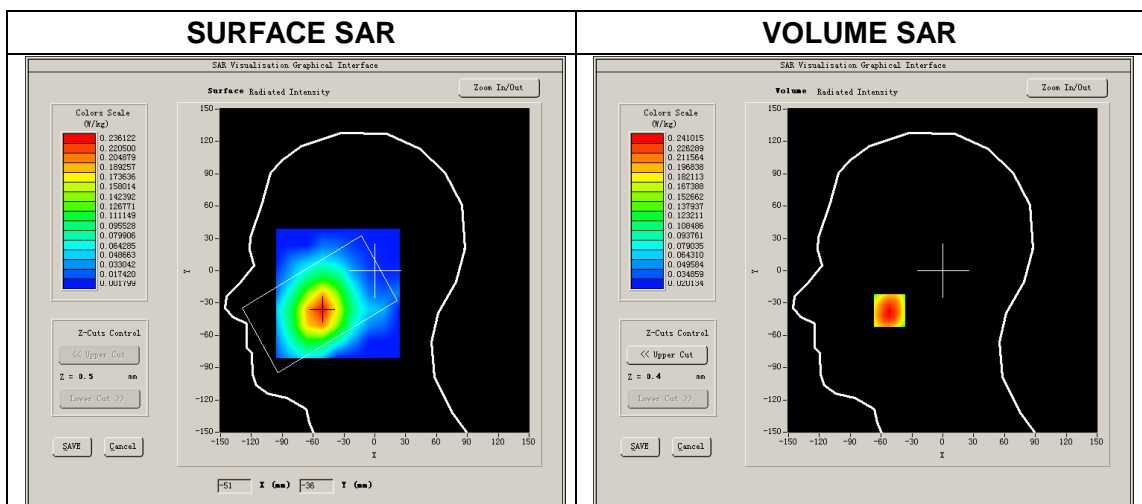

NOTE: This document is issued by MORLAB, the test report shall not be reproduced except in full without prior written permission of the company. The test results apply only to the particular sample(s) tested and to the specific tests carried out which is available on request for validation and information confirmed at our website.

Maximum location: X=-52.00, Y=-37.00

SAR Peak: 0.31W/kg

SAR 10g (W/Kg)	0.160602
SAR 1g (W/Kg)	0.228695

Z (mm)	0.00	4.00	9.00	14.00	19.00	24.00	29.00
SAR (W/Kg)	0.3091	0.2410	0.1766	0.1392	0.1010	0.0741	0.0572

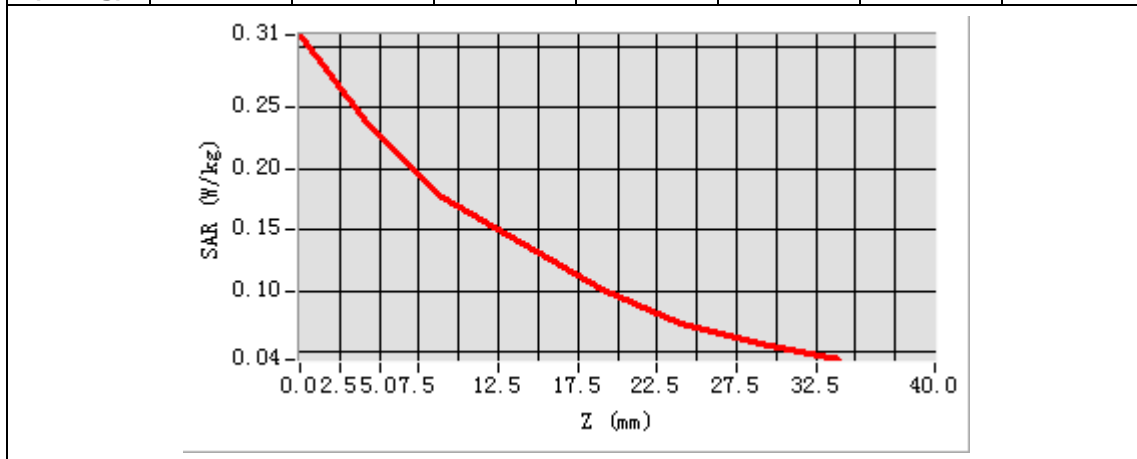

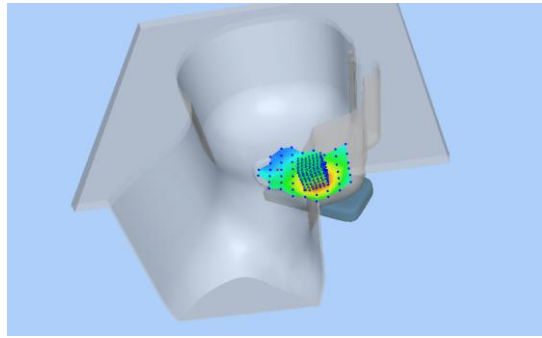
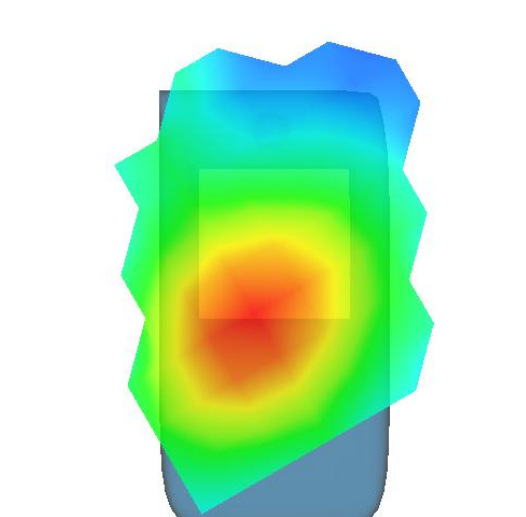
3D screen shot	Hot spot position
	

NOTE: This document is issued by MORLAB, the test report shall not be reproduced except in full without prior written permission of the company. The test results apply only to the particular sample(s) tested and to the specific tests carried out which is available on request for validation and information confirmed at our website.

MEASUREMENT 6

Type: Phone measurement (Complete)

Area scan resolution: dx=15mm,dy=15mm

Zoom scan resolution: dx=8mm, dy=8mm, dz=5mm

Date of measurement: 2018.04.09

Measurement duration: 16 minutes 58 seconds

A. Experimental conditions.

<u>Phantom File</u>	<u>surf_sam_plan.txt</u>
<u>Phantom</u>	<u>Right head</u>
<u>Device Position</u>	<u>Cheek</u>
<u>Band</u>	<u>LTE band 2</u>
<u>Channels</u>	<u>Middle</u>
<u>Signal</u>	<u>LTE</u>

B. SAR Measurement Results

Middle Band SAR (Channel 18900):

Frequency (MHz)	1879.500000
Relative permittivity (real part)	40.200199
Conductivity (S/m)	1.420724
Power drift (%)	2.809999
Ambient Temperature:	22.1°C
Liquid Temperature:	22.4°C
ConvF:	5.61
Duty cycle:	1:1

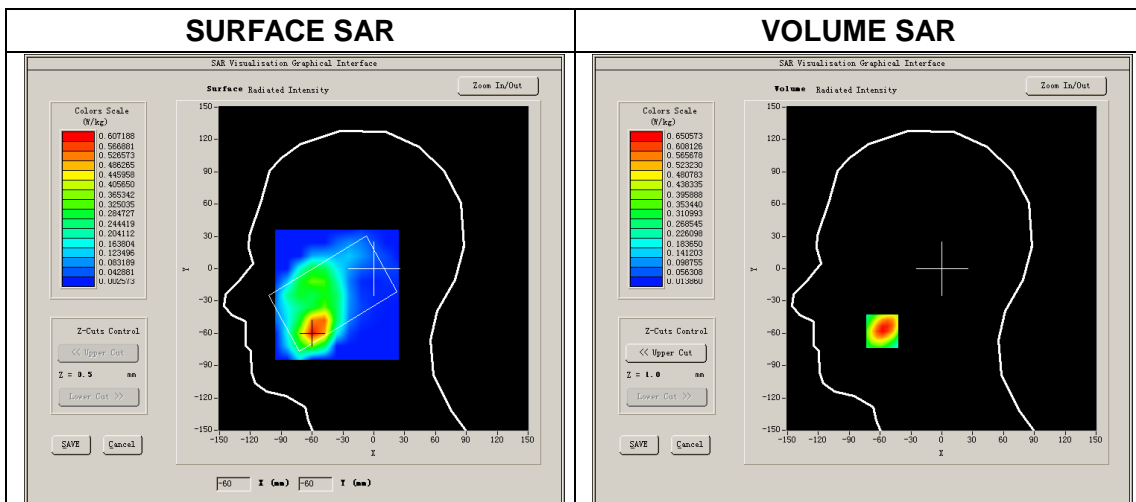

NOTE: This document is issued by MORLAB, the test report shall not be reproduced except in full without prior written permission of the company. The test results apply only to the particular sample(s) tested and to the specific tests carried out which is available on request for validation and information confirmed at our website.

Maximum location: X=-58.00, Y=-58.00

SAR Peak: 0.98W/kg

SAR 10g (W/Kg)	0.345002
SAR 1g (W/Kg)	0.613723

Z (mm)	0.00	4.00	9.00	14.00	19.00	24.00	29.00
SAR (W/Kg)	0.9902	0.6506	0.3865	0.2358	0.1538	0.0919	0.0571

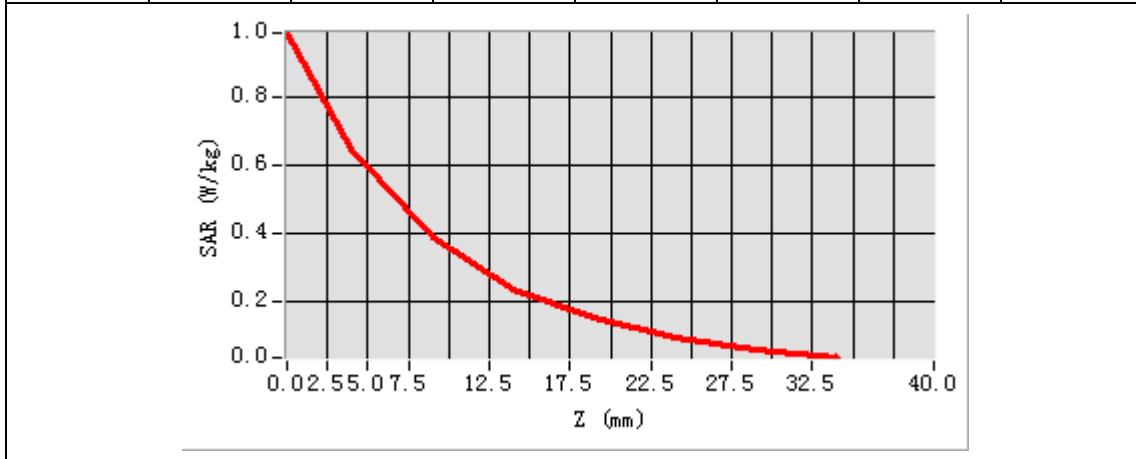

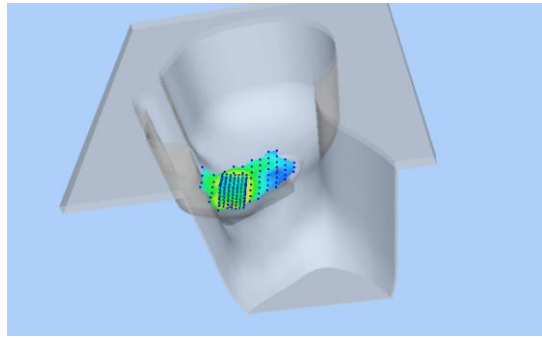
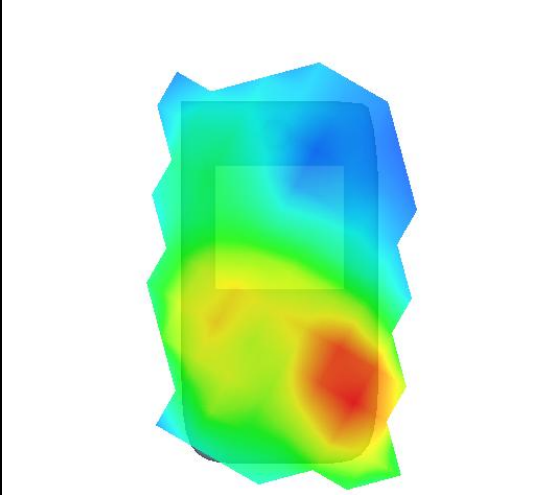
<p>3D screen shot</p>	<p>Hot spot position</p>
	

NOTE: This document is issued by MORLAB, the test report shall not be reproduced except in full without prior written permission of the company. The test results apply only to the particular sample(s) tested and to the specific tests carried out which is available on request for validation and information confirmed at our website.

MEASUREMENT 7

Type: Phone measurement (Complete)

Area scan resolution: dx=15mm,dy=15mm

Zoom scan resolution: dx=8mm, dy=8mm, dz=5mm

Date of measurement: 2018.04.09

Measurement duration: 13 minutes 17 seconds

A. Experimental conditions.

<u>Phantom File</u>	<u>surf_sam_plan.txt</u>
<u>Phantom</u>	<u>Left head</u>
<u>Device Position</u>	<u>Cheek</u>
<u>Band</u>	<u>LTE band 4</u>
<u>Channels</u>	<u>Low</u>
<u>Signal</u>	<u>LTE</u>

B. SAR Measurement Results

Lower Band SAR (Channel 20050):

Frequency (MHz)	1719.500000
Relative permittivity (real part)	40.227728
Conductivity (S/m)	1.300668
Power drift (%)	-0.230000
Ambient Temperature:	22.2°C
Liquid Temperature:	22.6°C
ConvF:	5.21
Crest factor:	1:1

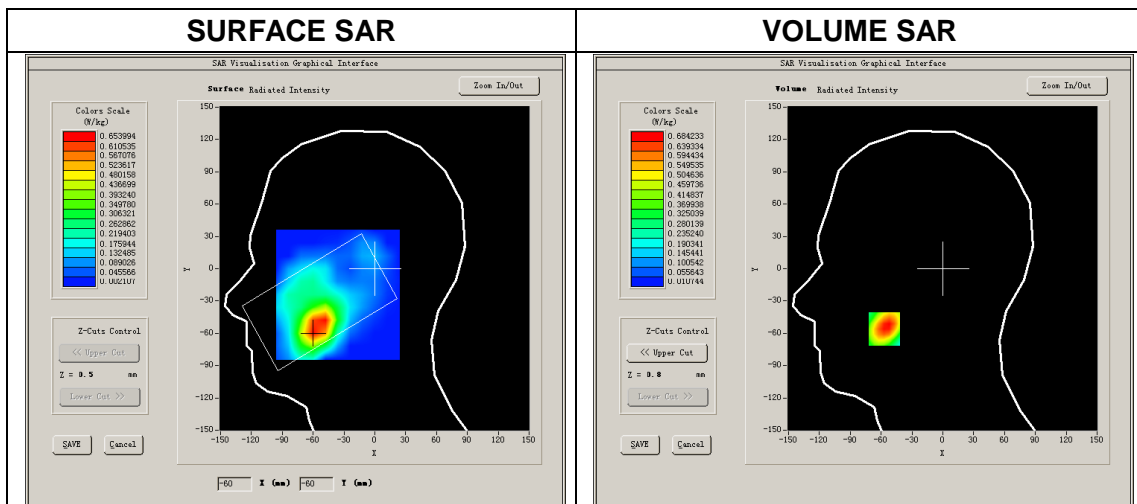

NOTE: This document is issued by MORLAB, the test report shall not be reproduced except in full without prior written permission of the company. The test results apply only to the particular sample(s) tested and to the specific tests carried out which is available on request for validation and information confirmed at our website.

Maximum location: X=-57.00, Y=-56.00

SAR Peak: 0.99W/kg

SAR 10g (W/Kg)	0.388950
SAR 1g (W/Kg)	0.653237

Z (mm)	0.00	4.00	9.00	14.00	19.00	24.00	29.00
SAR (W/Kg)	1.1054	0.6842	0.3869	0.2967	0.1737	0.1343	0.0701

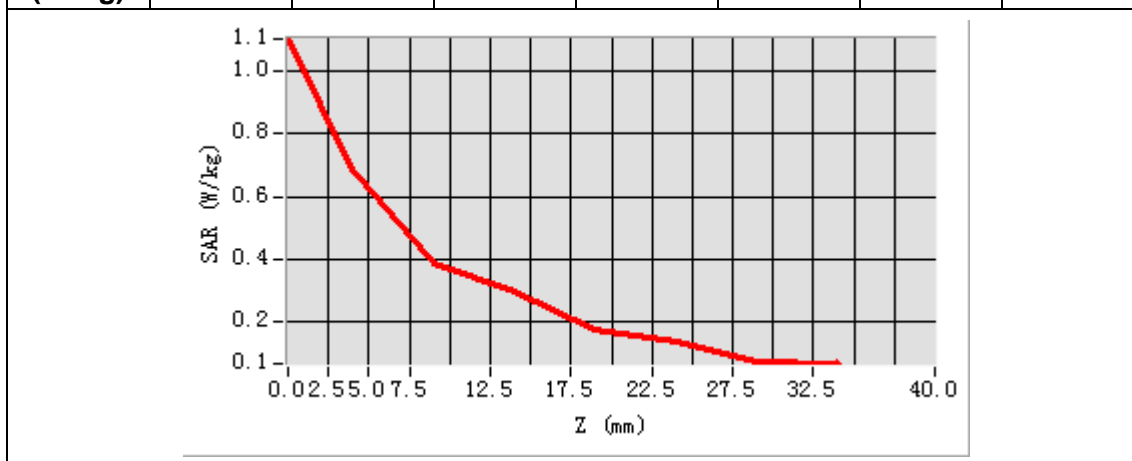

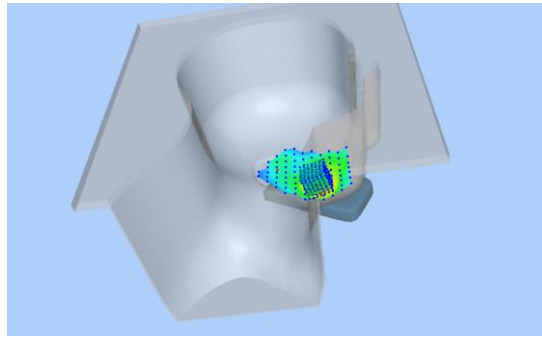
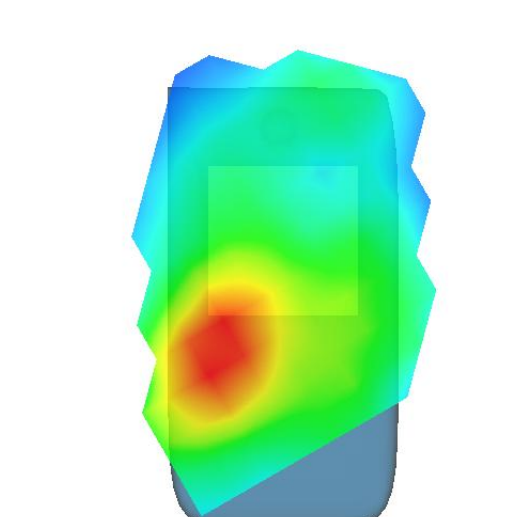
3D screen shot	Hot spot position
	

NOTE: This document is issued by MORLAB, the test report shall not be reproduced except in full without prior written permission of the company. The test results apply only to the particular sample(s) tested and to the specific tests carried out which is available on request for validation and information confirmed at our website.

MEASUREMENT 8

Type: Phone measurement (Complete)

Area scan resolution: dx=15mm,dy=15mm

Zoom scan resolution: dx=8mm, dy=8mm, dz=5mm

Date of measurement: 2018.04.08

Measurement duration: 11 minutes 19 seconds

A. Experimental conditions.

<u>Phantom File</u>	<u>surf_sam_plan.txt</u>
<u>Phantom</u>	<u>Right head</u>
<u>Device Position</u>	<u>Cheek</u>
<u>Band</u>	<u>LTE band 12</u>
<u>Channels</u>	<u>Middle</u>
<u>Signal</u>	<u>LTE</u>

B. SAR Measurement Results

Middle Band SAR (Channel 23095):

Frequency (MHz)	707.500000
Relative permittivity (real part)	42.526667
Conductivity (S/m)	0.994404
Power drift (%)	-3.280000
Ambient Temperature:	22.6°C
Liquid Temperature:	21.2°C
ConvF:	6.44
Crest factor:	1:1

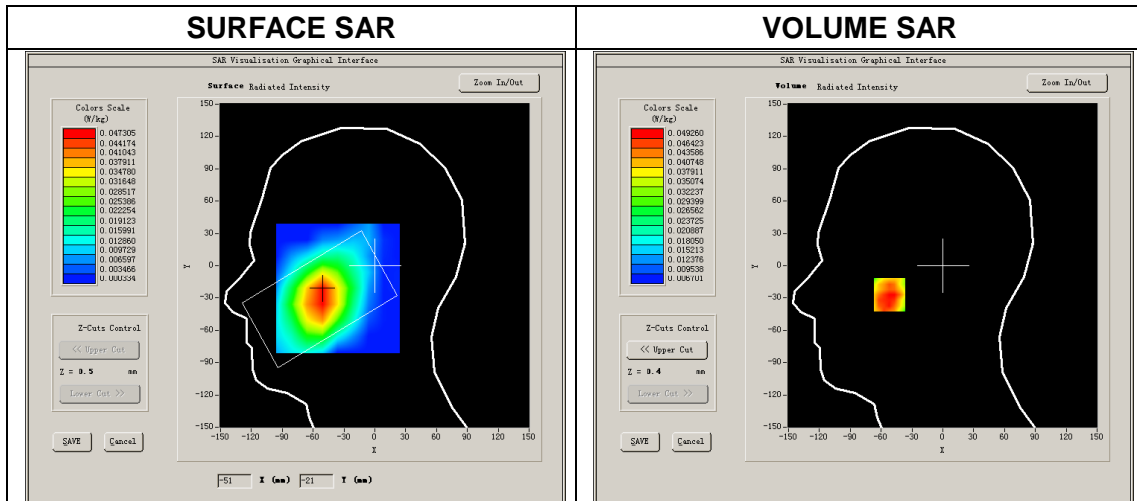

NOTE: This document is issued by MORLAB, the test report shall not be reproduced except in full without prior written permission of the company. The test results apply only to the particular sample(s) tested and to the specific tests carried out which is available on request for validation and information confirmed at our website.

Maximum location: X=-52.00, Y=-27.00

SAR Peak: 0.07W/kg

SAR 10g (W/Kg)	0.035930
SAR 1g (W/Kg)	0.048310

Z (mm)	0.00	4.00	9.00	14.00	19.00	24.00	29.00
SAR (W/Kg)	0.0531	0.0493	0.0397	0.0333	0.0252	0.0195	0.0178

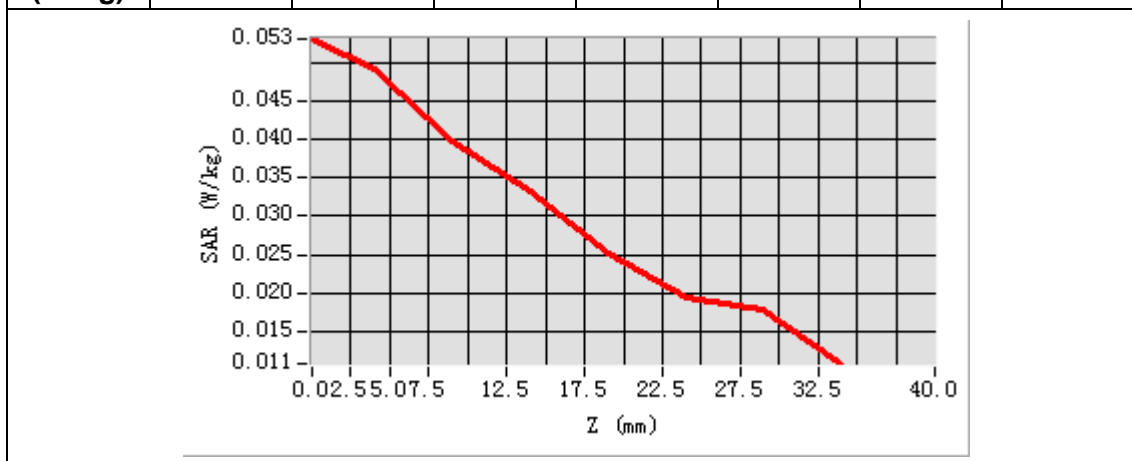

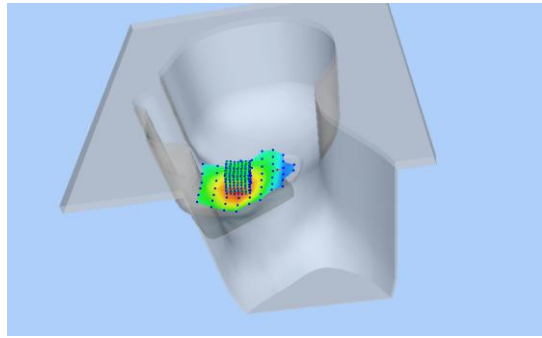
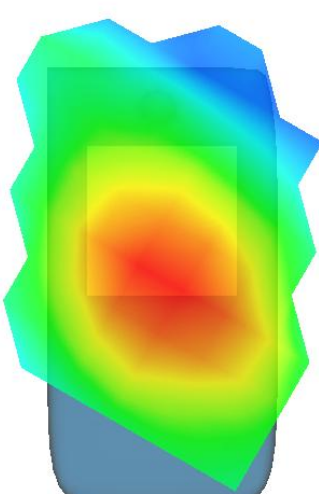
3D screen shot	Hot spot position
	

NOTE: This document is issued by MORLAB, the test report shall not be reproduced except in full without prior written permission of the company. The test results apply only to the particular sample(s) tested and to the specific tests carried out which is available on request for validation and information confirmed at our website.

MEASUREMENT 9

Type: Phone measurement (Complete)

Area scan resolution: dx=15mm,dy=15mm

Zoom scan resolution: dx=8mm, dy=8mm, dz=5mm

Date of measurement: 2018.04.08

Measurement duration: 16 minutes 27 seconds

A. Experimental conditions.

<u>Phantom File</u>	<u>surf_sam_plan.txt</u>
<u>Phantom</u>	<u>Left head</u>
<u>Device Position</u>	<u>Cheek</u>
<u>Band</u>	<u>LTE band 17</u>
<u>Channels</u>	<u>High</u>
<u>Signal</u>	<u>LTE</u>

B. SAR Measurement Results

Higher Band SAR (Channel 23800):

Frequency (MHz)	711.000000
Relative permittivity (real part)	41.528002
Conductivity (S/m)	1.012734
Power drift (%)	-1.800000
Ambient Temperature:	22.6°C
Liquid Temperature:	21.2°C
ConvF:	6.44
Crest factor:	1:1

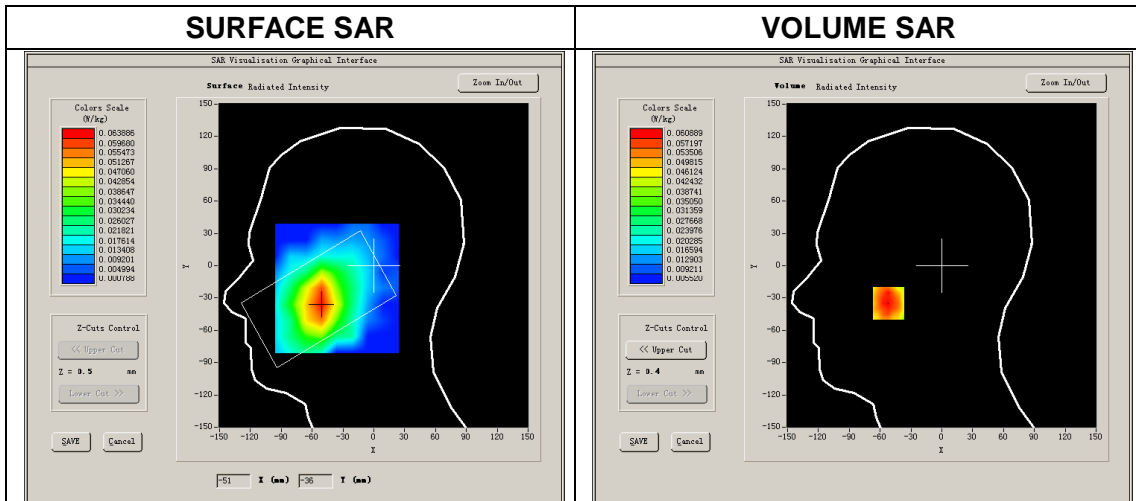

NOTE: This document is issued by MORLAB, the test report shall not be reproduced except in full without prior written permission of the company. The test results apply only to the particular sample(s) tested and to the specific tests carried out which is available on request for validation and information confirmed at our website.

Maximum location: X=-52.00, Y=-35.00

SAR Peak: 0.09W/kg

SAR 10g (W/Kg)	0.043204
SAR 1g (W/Kg)	0.058881

Z (mm)	0.00	4.00	9.00	14.00	19.00	24.00	29.00
SAR (W/Kg)	0.0842	0.0609	0.0435	0.0373	0.0293	0.0219	0.0180

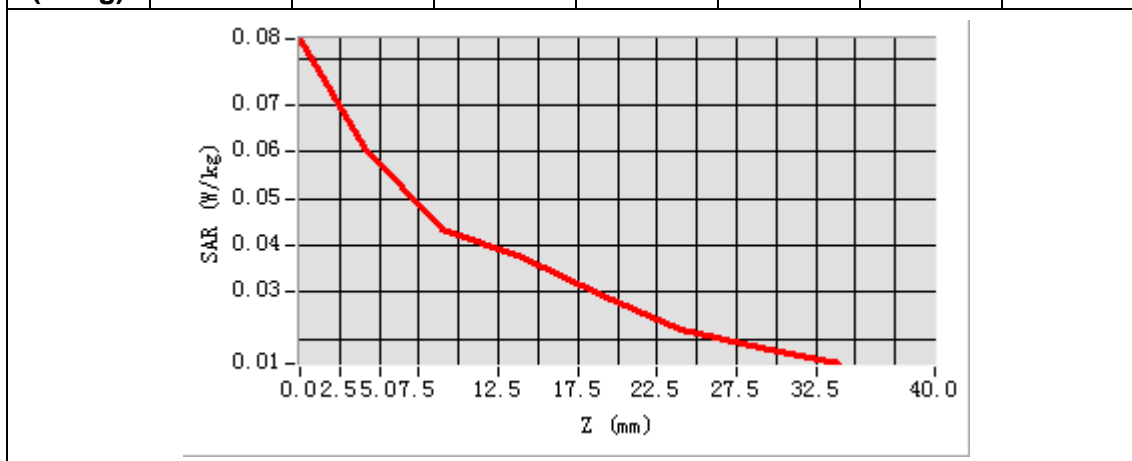

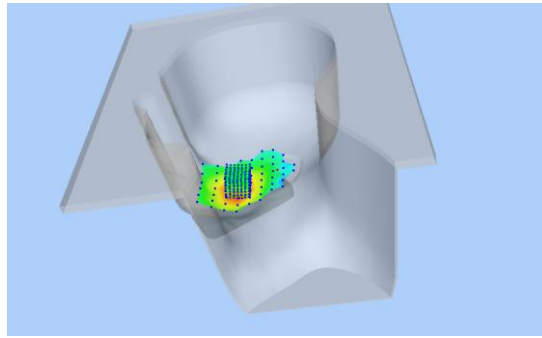
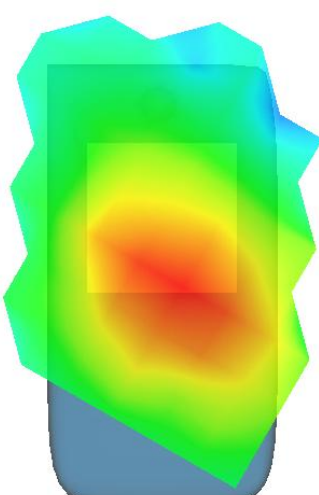
3D screen shot	Hot spot position
	

NOTE: This document is issued by MORLAB, the test report shall not be reproduced except in full without prior written permission of the company. The test results apply only to the particular sample(s) tested and to the specific tests carried out which is available on request for validation and information confirmed at our website.

MEASUREMENT 10

Type: Phone measurement (Complete)

Area scan resolution: dx=12mm,dy=12mm

Zoom scan resolution: dx=5mm, dy=5mm, dz=4mm

Date of measurement: 2018.04.12

Measurement duration: 18 minutes 13 seconds

A. Experimental conditions.

<u>Phantom File</u>	<u>surf_sam_plan.txt</u>
<u>Phantom</u>	<u>Right head</u>
<u>Device Position</u>	<u>Cheek</u>
<u>Band</u>	<u>IEEE 802.11b ISM</u>
<u>Channels</u>	<u>Middle</u>
<u>Signal</u>	<u>DSSS</u>

B. SAR Measurement Results

Middle Band SAR (Channel 6):

Frequency (MHz)	2437.000000
Relative permittivity (real part)	39.226002
Conductivity (S/m)	1.788081
Power Drift (%)	-0.140000
Ambient Temperature:	22.0°C
Liquid Temperature:	21.8°C
ConvF:	4.74
Crest factor:	1:1

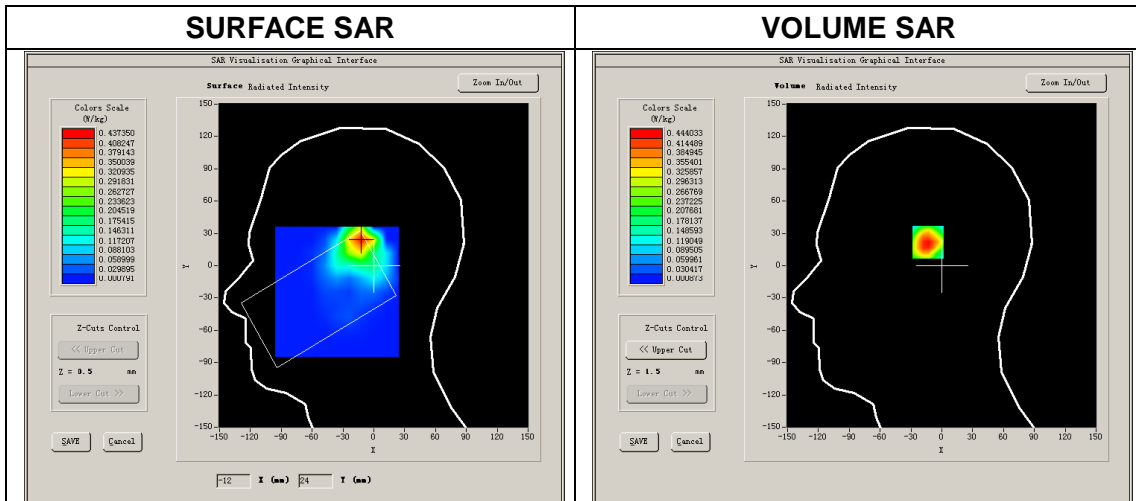

NOTE: This document is issued by MORLAB, the test report shall not be reproduced except in full without prior written permission of the company. The test results apply only to the particular sample(s) tested and to the specific tests carried out which is available on request for validation and information confirmed at our website.

Maximum location: X=-12.00, Y=24.00

SAR Peak: 0.82W/kg

SAR 10g (W/Kg)	0.200882
SAR 1g (W/Kg)	0.422558

Z (mm)	0.00	4.00	8.00	12.00	16.00	20.00	24.00	28.00
SAR (W/Kg)	0.8291	0.4440	0.2213	0.1115	0.0545	0.0341	0.0180	0.0075

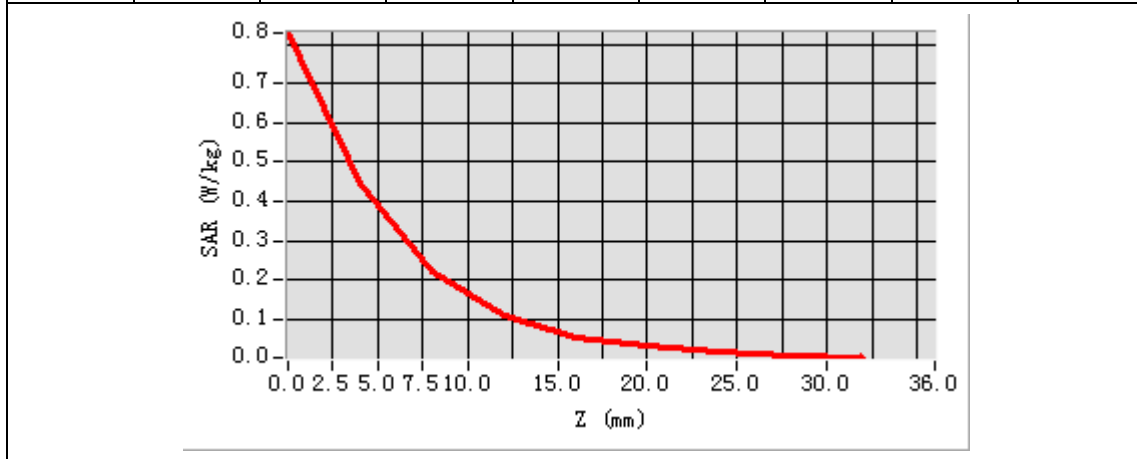

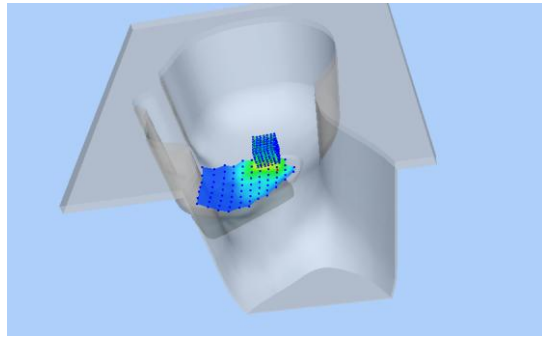
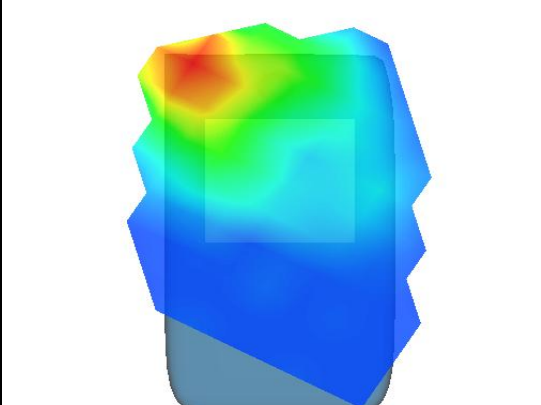
3D screen shot	Hot spot position
	

NOTE: This document is issued by MORLAB, the test report shall not be reproduced except in full without prior written permission of the company. The test results apply only to the particular sample(s) tested and to the specific tests carried out which is available on request for validation and information confirmed at our website.

MEASUREMENT 11

Type: Phone measurement (Complete)

Area scan resolution: dx=10mm,dy=10mm

Zoom scan resolution: dx=4mm, dy=4mm, dz=2mm

Date of measurement: 2018.04.13

Measurement duration: 27 minutes 28 seconds

A. Experimental conditions.

<u>Phantom File</u>	<u>surf_sam_plan.txt</u>
<u>Phantom</u>	<u>Right head</u>
<u>Device Position</u>	<u>Tilt</u>
<u>Band</u>	<u>IEEE 802.11a U-NII</u>
<u>Channels</u>	<u>High</u>
<u>Signal</u>	<u>OFDM</u>

B. SAR Measurement Results

Higher Band SAR (Channel 48):

Frequency (MHz)	5240.000000
Relative permittivity (real part)	36.029921
Conductivity (S/m)	4.689698
Power Drift (%)	-1.380000
Ambient Temperature:	22.9°C
Liquid Temperature:	22.1°C
ConvF:	21.61
Crest factor:	1:1

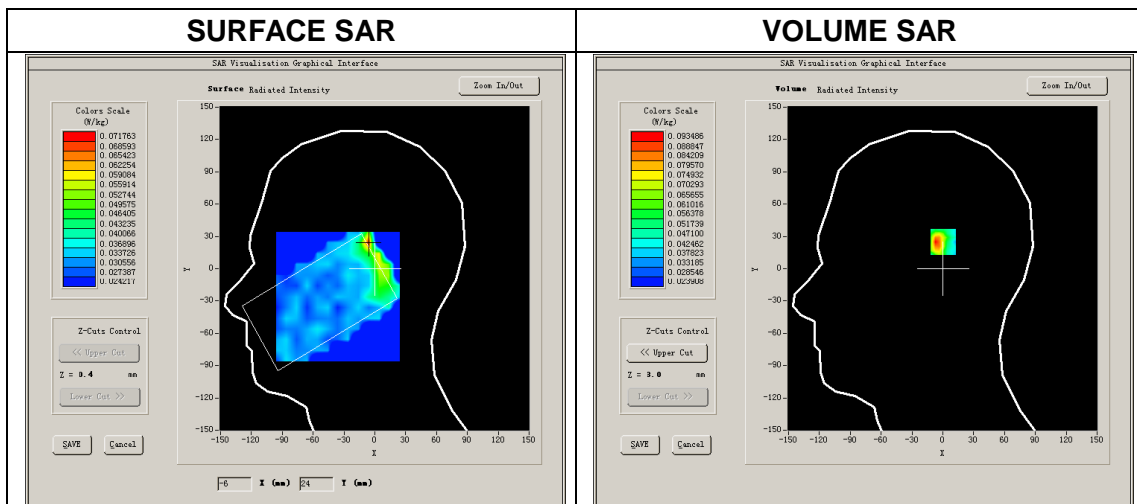

NOTE: This document is issued by MORLAB, the test report shall not be reproduced except in full without prior written permission of the company. The test results apply only to the particular sample(s) tested and to the specific tests carried out which is available on request for validation and information confirmed at our website.

Maximum location: X=5.00, Y=27.00

SAR Peak: 0.22W/kg

SAR 10g (W/Kg)	0.048830
SAR 1g (W/Kg)	0.087502

Z (m m)	0.00	4.00	6.00	8.00	10.0	12.0	14.0	16.0	18.0	20.0	22.0	24.0
SA R (W/ Kg)	0.25 50	0.09 35	0.03 98	0.04 14	0.03 39	0.03 43	0.03 17	0.03 32	0.03 02	0.02 82	0.02 95	0.02 80

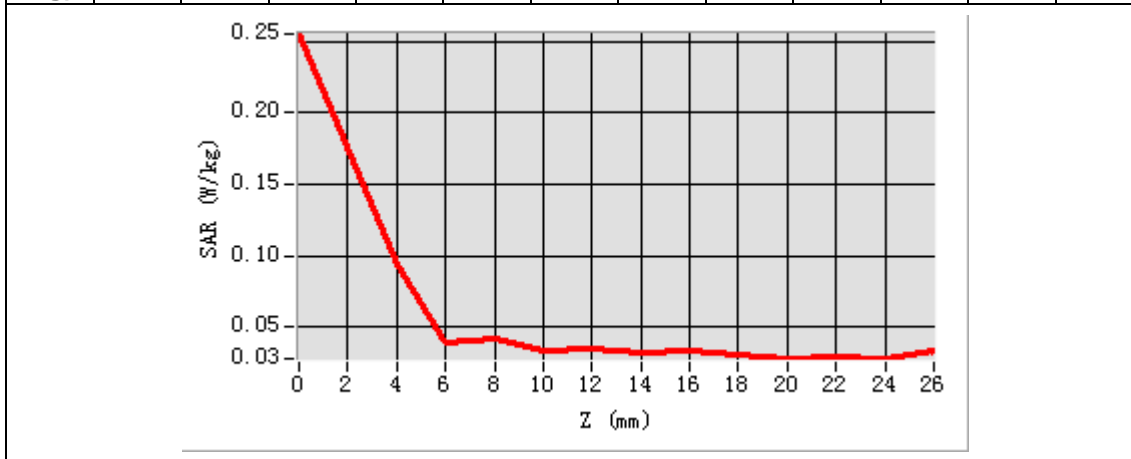

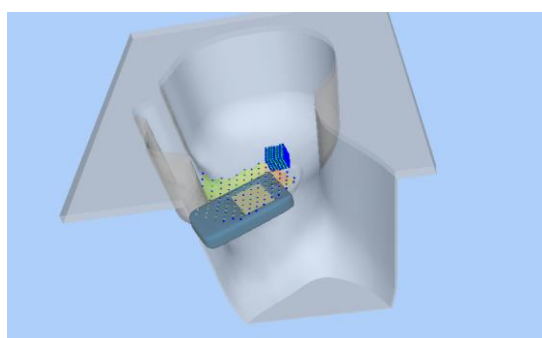
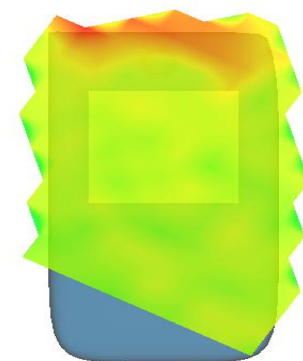
3D screen shot	Hot spot position
	

NOTE: This document is issued by MORLAB, the test report shall not be reproduced except in full without prior written permission of the company. The test results apply only to the particular sample(s) tested and to the specific tests carried out which is available on request for validation and information confirmed at our website.



MEASUREMENT 12

Type: Phone measurement (Complete)
 Area scan resolution: dx=10mm,dy=10mm
 Zoom scan resolution: dx=4mm, dy=4mm, dz=2mm
 Date of measurement: 2018.04.13
 Measurement duration: 27 minutes 37 seconds

A. Experimental conditions.

Phantom File	surf_sam_plan.txt
Phantom	Left head
Device Position	Cheek
Band	IEEE 802.11a U-NII
Channels	Middle
Signal	OFDM

B. SAR Measurement Results

Middle Band SAR (Channel 60):

Frequency (MHz)	5300.000000
Relative permittivity (real part)	35.930002
Conductivity (S/m)	4.749694
Power Drift (%)	-2.790001
Ambient Temperature:	22.9°C
Liquid Temperature:	22.1°C
ConvF:	21.61
Crest factor:	1:1

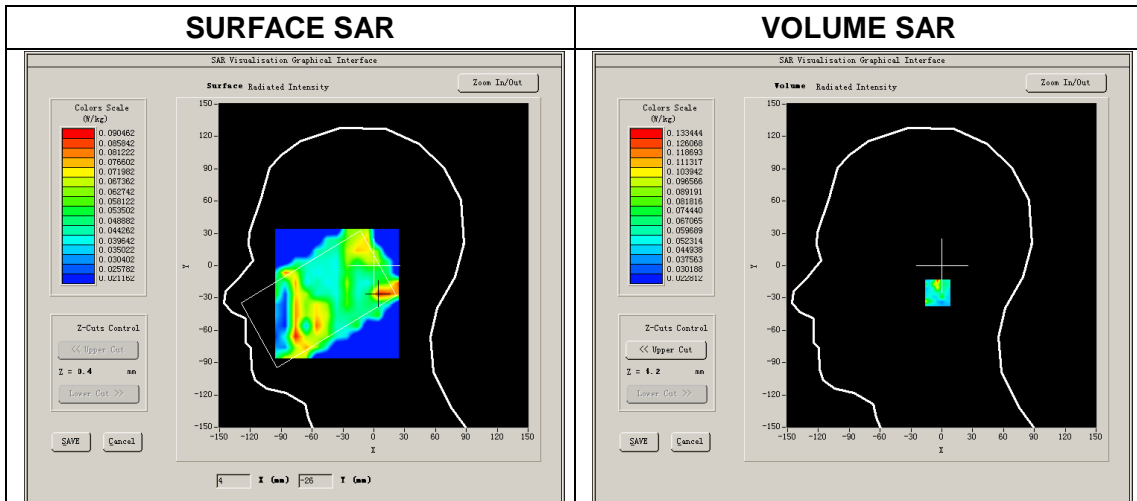

NOTE: This document is issued by MORLAB, the test report shall not be reproduced except in full without prior written permission of the company. The test results apply only to the particular sample(s) tested and to the specific tests carried out which is available on request for validation and information confirmed at our website.

Maximum location: X=7.00, Y=-25.00

SAR Peak: 0.40W/kg

SAR 10g (W/Kg)	0.055453
SAR 1g (W/Kg)	0.102645

Z (m m)	0.00	4.00	6.00	8.00	10.0	12.0	14.0	16.0	18.0	20.0	22.0	24.0
SA R (W/ Kg)	0.4183	0.1334	0.0441	0.0428	0.0490	0.0462	0.0465	0.0502	0.0489	0.0445	0.0443	0.0432

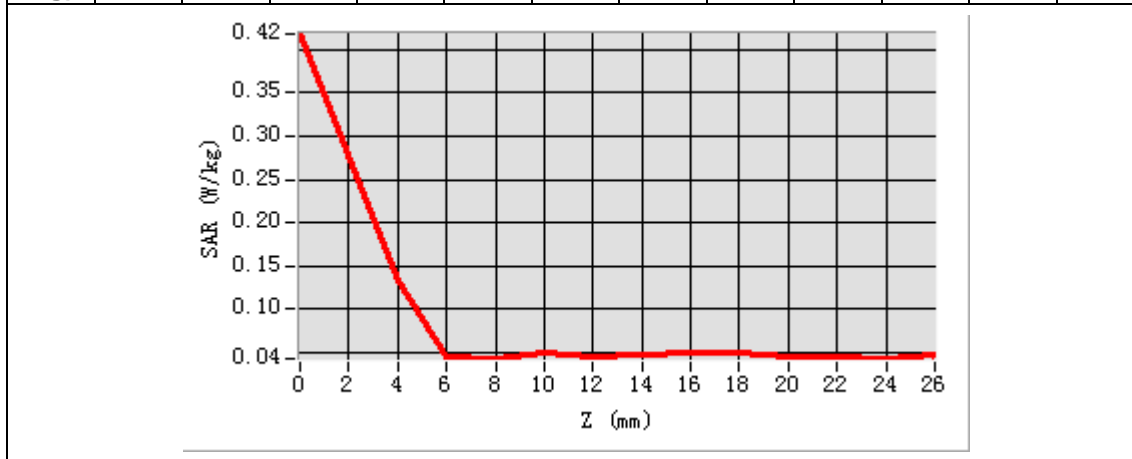

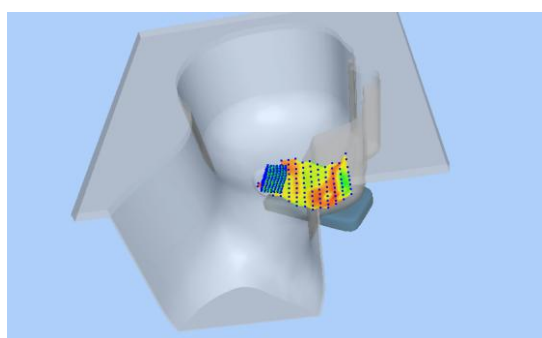
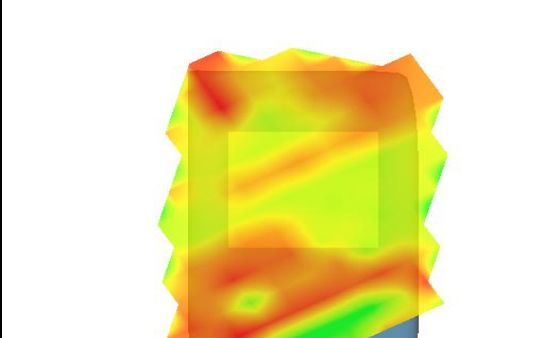
3D screen shot	Hot spot position
	

NOTE: This document is issued by MORLAB, the test report shall not be reproduced except in full without prior written permission of the company. The test results apply only to the particular sample(s) tested and to the specific tests carried out which is available on request for validation and information confirmed at our website.

MEASUREMENT 13

Type: Phone measurement (Complete)

Area scan resolution: dx=10mm,dy=10mm

Zoom scan resolution: dx=4mm, dy=4mm, dz=2mm

Date of measurement: 2018.04.13

Measurement duration: 27 minutes 2 seconds

A. Experimental conditions.

Phantom File	<u>surf_sam_plan.txt</u>
Phantom	<u>Left head</u>
Device Position	<u>Cheek</u>
Band	<u>IEEE 802.11a U-NII</u>
Channels	<u>Middle</u>
Signal	<u>OFDM</u>

B. SAR Measurement Results

Middle Band SAR (Channel 120):

Frequency (MHz)	5600.000000
Relative permittivity (real part)	35.500000
Conductivity (S/m)	5.071111
Power Drift (%)	0.930000
Ambient Temperature:	22.9°C
Liquid Temperature:	22.1°C
ConvF:	22.42
Crest factor:	1:1

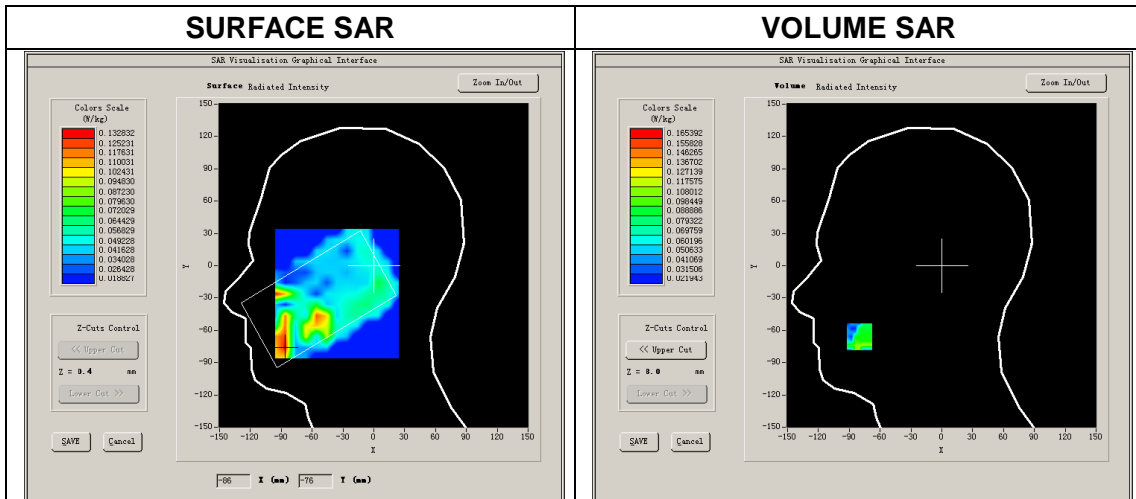

NOTE: This document is issued by MORLAB, the test report shall not be reproduced except in full without prior written permission of the company. The test results apply only to the particular sample(s) tested and to the specific tests carried out which is available on request for validation and information confirmed at our website.

Maximum location: X=-80.00, Y=-66.00

SAR Peak: 0.41W/kg

SAR 10g (W/Kg)	0.116030
SAR 1g (W/Kg)	0.152822

Z (m m)	0.00	4.00	6.00	8.00	10.0	12.0	14.0	16.0	18.0	20.0	22.0	24.0
SA	0.45	0.11	0.08	0.07	0.04	0.08	0.10	0.12	0.13	0.04	0.12	0.04
R	42	22	74	61	13	15	48	70	56	43	16	86
(W/ Kg)												

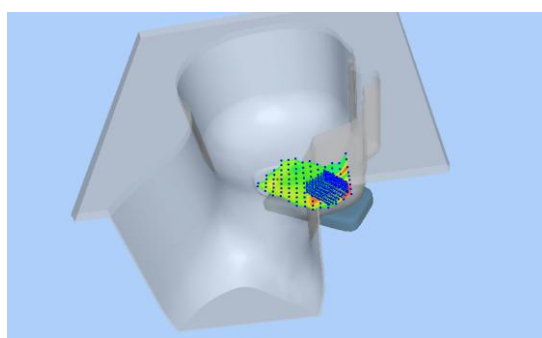
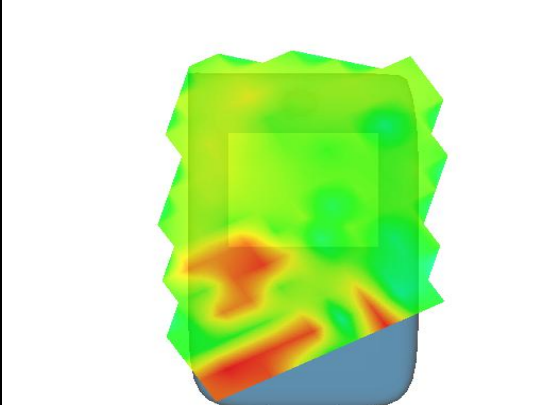

3D screen shot	Hot spot position
	

NOTE: This document is issued by MORLAB, the test report shall not be reproduced except in full without prior written permission of the company. The test results apply only to the particular sample(s) tested and to the specific tests carried out which is available on request for validation and information confirmed at our website.

MEASUREMENT 14

Type: Phone measurement (Complete)
 Area scan resolution: dx=10mm,dy=10mm
 Zoom scan resolution: dx=4mm, dy=4mm, dz=2mm
 Date of measurement: 2018.04.13
 Measurement duration: 27 minutes 12 seconds

A. Experimental conditions.

Phantom File	surf_sam_plan.txt
Phantom	Right head
Device Position	Cheek
Band	IEEE 802.11n-HT40
Channels	High
Signal	OFDM

B. SAR Measurement Results

Higher Band SAR (Channel 159):

Frequency (MHz)	5795.000000
Relative permittivity (real part)	35.305000
Conductivity (S/m)	5.266528
Power Drift (%)	1.320000
Ambient Temperature:	22.9°C
Liquid Temperature:	22.1°C
ConvF:	22.42
Crest factor:	1:1

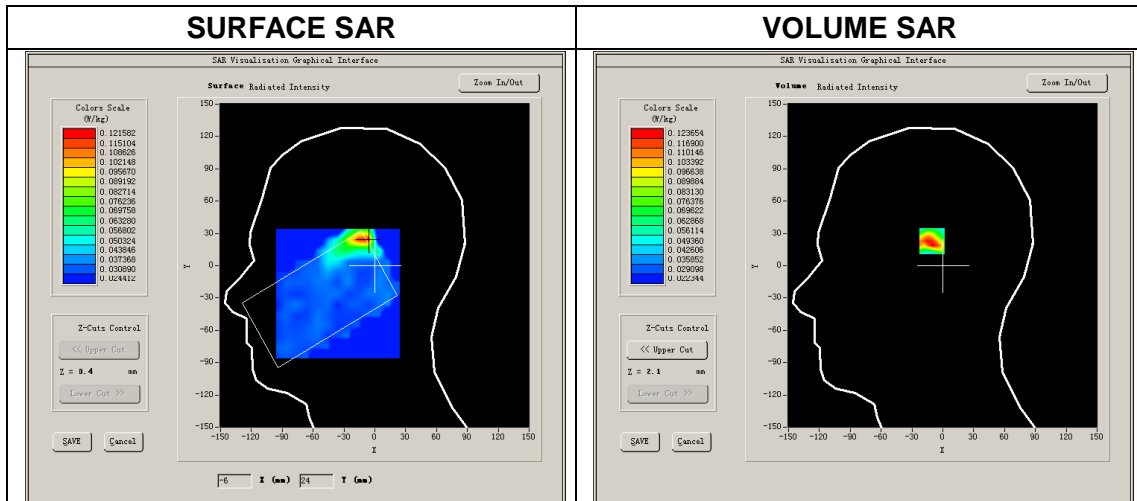

NOTE: This document is issued by MORLAB, the test report shall not be reproduced except in full without prior written permission of the company. The test results apply only to the particular sample(s) tested and to the specific tests carried out which is available on request for validation and information confirmed at our website.

Maximum location: X=-8.00, Y=25.00

SAR Peak: 0.32W/kg

SAR 10g (W/Kg)	0.061565
SAR 1g (W/Kg)	0.125888

Z (m m)	0.00	4.00	6.00	8.00	10.0	12.0	14.0	16.0	18.0	20.0	22.0	24.0
SA R (W/ Kg)	0.3247	0.1237	0.0599	0.0479	0.0308	0.0338	0.0294	0.0291	0.0340	0.0292	0.0377	0.0301

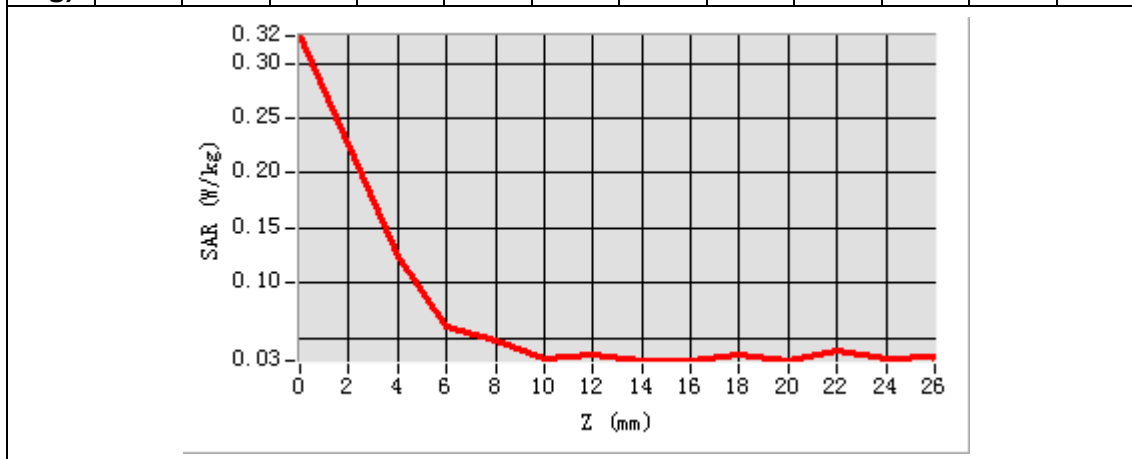

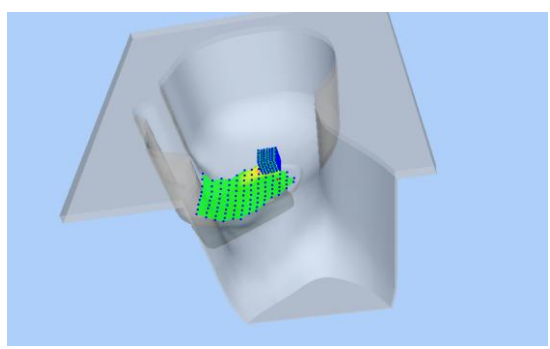
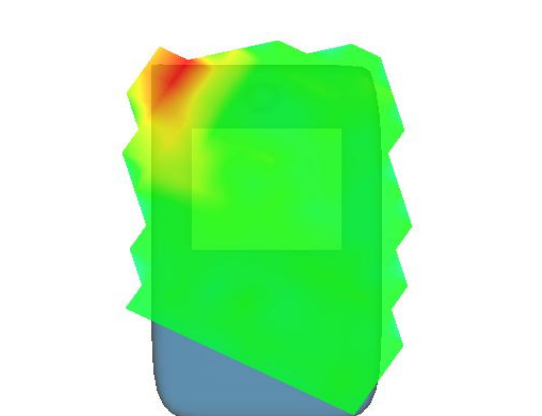
3D screen shot	Hot spot position
	

NOTE: This document is issued by MORLAB, the test report shall not be reproduced except in full without prior written permission of the company. The test results apply only to the particular sample(s) tested and to the specific tests carried out which is available on request for validation and information confirmed at our website.

MEASUREMENT 15

Type: Phone measurement (Complete)

Area scan resolution: dx=15mm,dy=15mm

Zoom scan resolution: dx=8mm, dy=8mm, dz=5mm

Date of measurement: 2018.04.11

Measurement duration: 16 minutes 2 seconds

A. Experimental conditions.

<u>Phantom File</u>	<u>surf_sam_plan.txt</u>
<u>Phantom</u>	<u>Flat</u>
<u>Device Position</u>	<u>Body</u>
<u>Band</u>	<u>CUSTOM (GPRS850 4Tx)</u>
<u>Channels</u>	<u>Middle</u>
<u>Signal</u>	<u>GPRS</u>

B. SAR Measurement Results

Frequency (MHz)	836.599976
Relative permittivity (real part)	55.275076
Conductivity (S/m)	0.981353
Power drift (%)	0.060000
Ambient Temperature:	22.6°C
Liquid Temperature:	21.2°C
ConvF:	6.37
Crest factor:	1:2.08

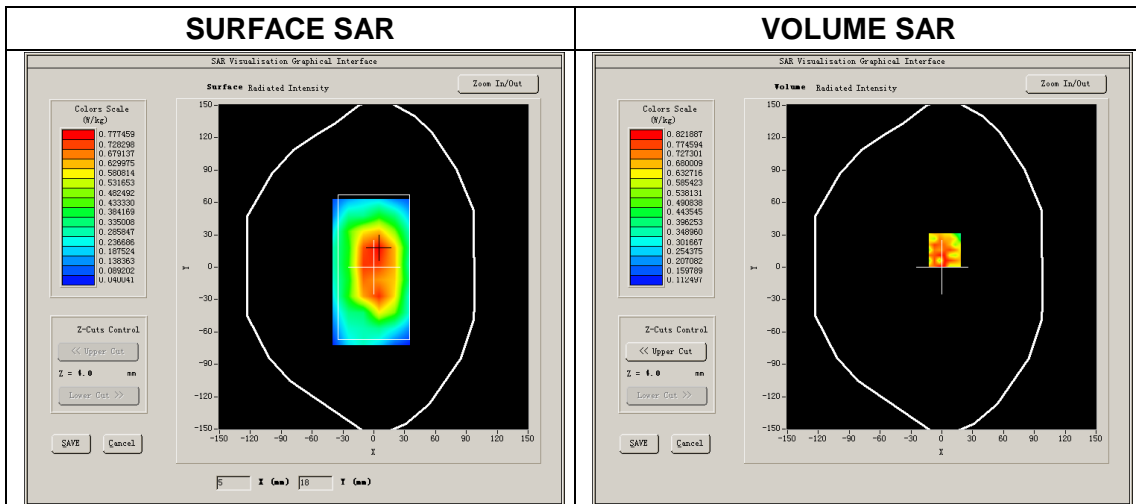

NOTE: This document is issued by MORLAB, the test report shall not be reproduced except in full without prior written permission of the company. The test results apply only to the particular sample(s) tested and to the specific tests carried out which is available on request for validation and information confirmed at our website.

Maximum location: X=3.00, Y=16.00

SAR Peak: 1.32W/kg

SAR 10g (W/Kg)	0.556847
SAR 1g (W/Kg)	0.740009

Z (mm)	0.00	4.00	9.00	14.00	19.00	24.00	29.00
SAR (W/Kg)	1.2628	0.8219	0.5236	0.4570	0.3029	0.2388	0.1462

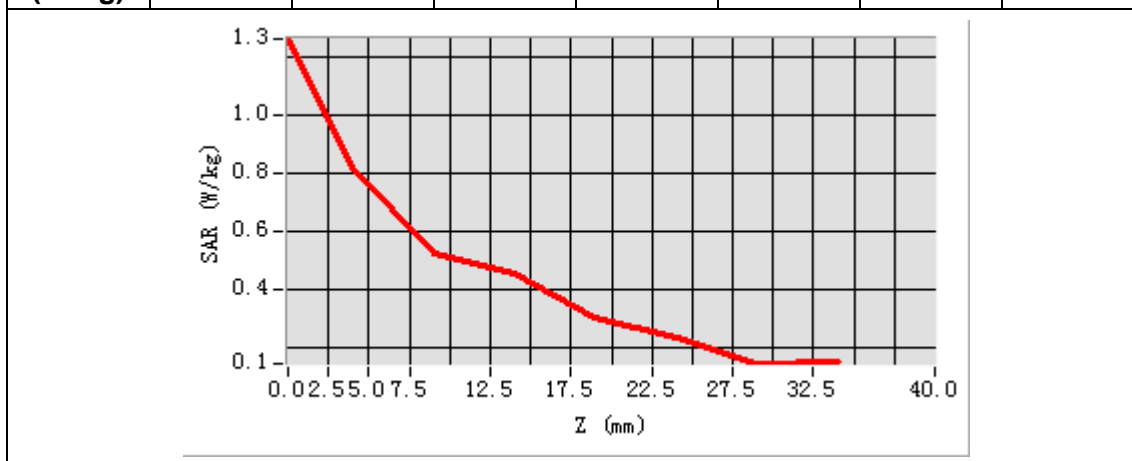

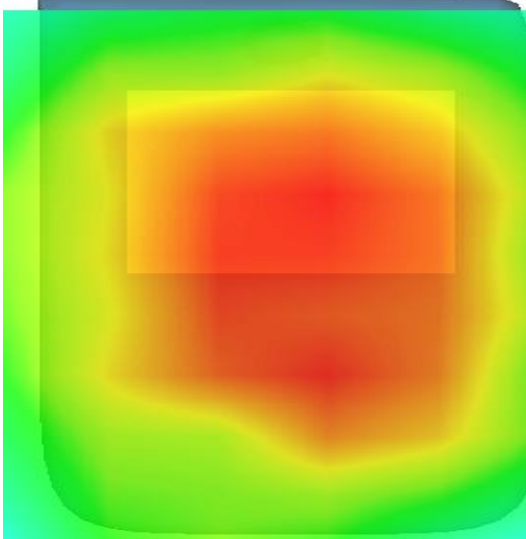
3D screen shot	Hot spot position
	

NOTE: This document is issued by MORLAB, the test report shall not be reproduced except in full without prior written permission of the company. The test results apply only to the particular sample(s) tested and to the specific tests carried out which is available on request for validation and information confirmed at our website.

MEASUREMENT 16

Type: Phone measurement (Complete)

Area scan resolution: dx=15mm,dy=15mm

Zoom scan resolution: dx=8mm, dy=8mm, dz=5mm

Date of measurement: 2018.04.10

Measurement duration: 16 minutes 25 seconds

A. Experimental conditions.

<u>Phantom File</u>	<u>surf_sam_plan.txt</u>
<u>Phantom</u>	<u>Flat</u>
<u>Device Position</u>	<u>Body</u>
<u>Band</u>	<u>CUSTOM (GPRS1900_4Tx)</u>
<u>Channels</u>	<u>Low</u>
<u>Signal</u>	<u>GPRS</u>

B. SAR Measurement Results

Frequency (MHz)	1880.000000
Relative permittivity (real part)	53.436999
Conductivity (S/m)	1.509711
Power drift (%)	-2.700000
Ambient Temperature:	22.1°C
Liquid Temperature:	22.4°C
ConvF:	5.61
Duty cycle:	1:2.08

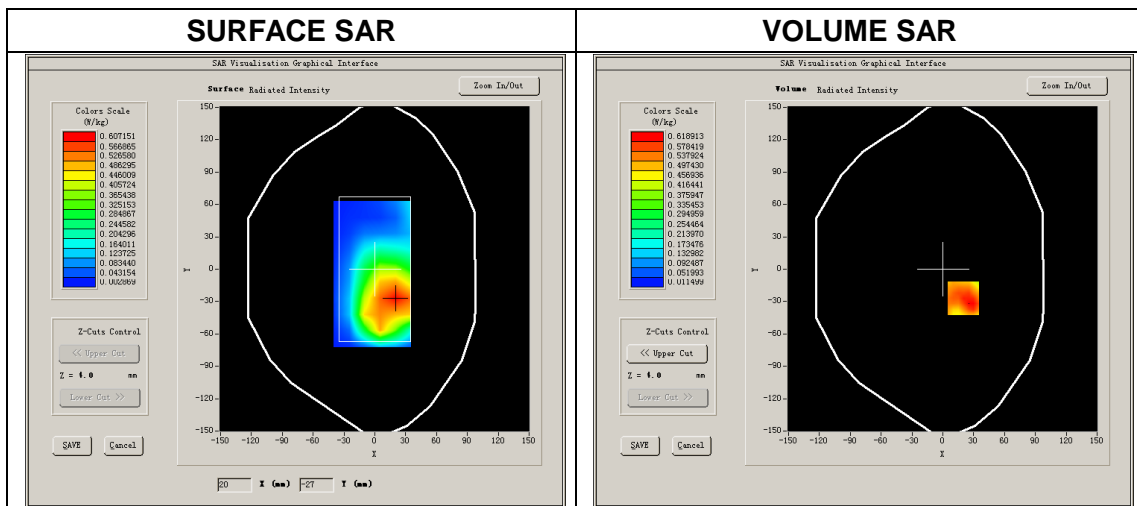

NOTE: This document is issued by MORLAB, the test report shall not be reproduced except in full without prior written permission of the company. The test results apply only to the particular sample(s) tested and to the specific tests carried out which is available on request for validation and information confirmed at our website.

Maximum location: X=20.00, Y=-27.00

SAR Peak: 0.92W/kg

SAR 10g (W/Kg)	0.348324
SAR 1g (W/Kg)	0.586641

Z (mm)	0.00	4.00	9.00	14.00	19.00	24.00	29.00
SAR (W/Kg)	0.9752	0.6189	0.3446	0.2135	0.1190	0.0745	0.0390

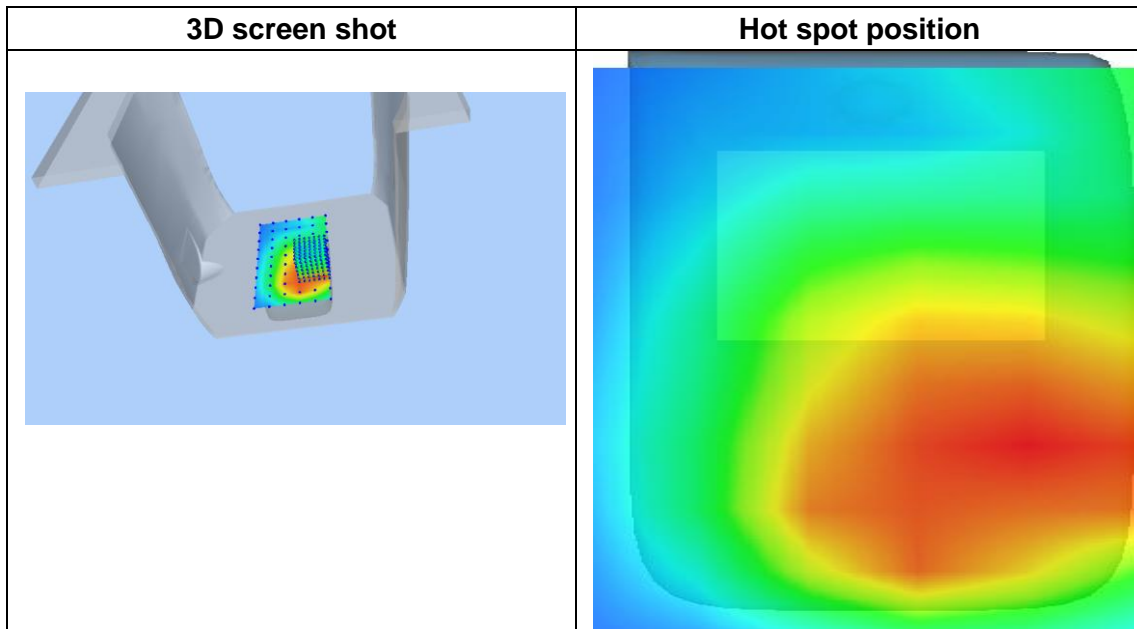
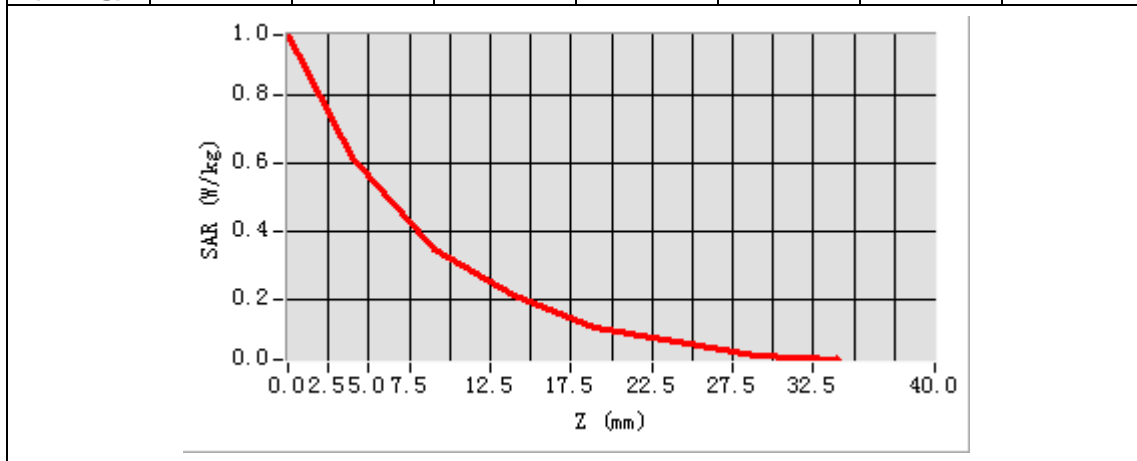

NOTE: This document is issued by MORLAB, the test report shall not be reproduced except in full without prior written permission of the company. The test results apply only to the particular sample(s) tested and to the specific tests carried out which is available on request for validation and information confirmed at our website.



MEASUREMENT 17

Type: Phone measurement (Complete)
 Area scan resolution: dx=15mm,dy=15mm
 Zoom scan resolution: dx=8mm, dy=8mm, dz=5mm
 Date of measurement: 2018.04.10
 Measurement duration: 16 minutes 24 seconds

A. Experimental conditions.

Phantom File	<u>surf_sam_plan.txt</u>
Phantom	<u>Flat</u>
Device Position	<u>Body</u>
Band	<u>Band2_WCDMA1900</u>
Channels	<u>Low</u>
Signal	<u>RMC</u>

B. SAR Measurement Results

Lower Band SAR (Channel 9262):

Frequency (MHz)	1852.400024
Relative permittivity (real part)	53.399999
Conductivity (S/m)	1.501109
Power drift (%)	-0.380000
Ambient Temperature:	22.1°C
Liquid Temperature:	22.4°C
ConvF:	5.71
Duty cycle:	1:1

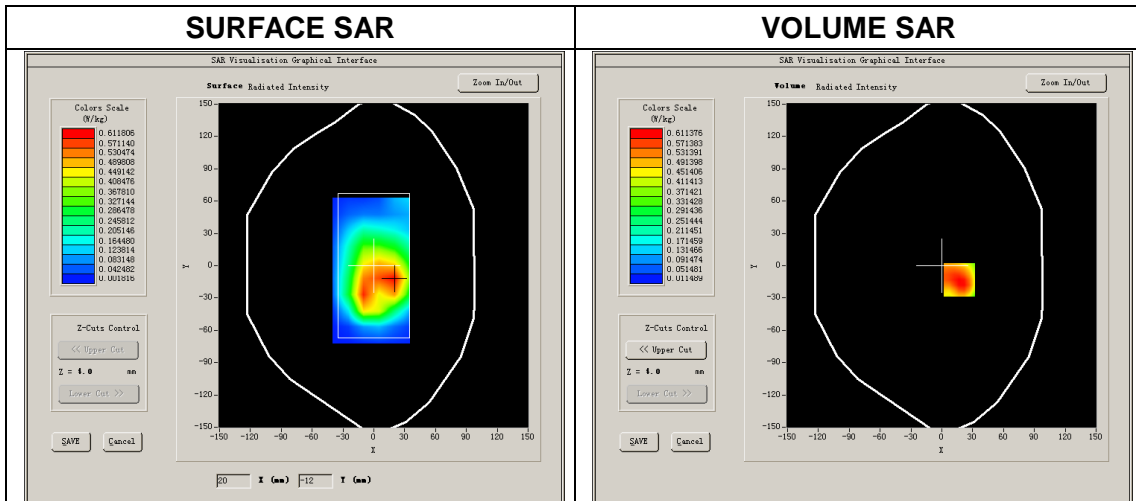

NOTE: This document is issued by MORLAB, the test report shall not be reproduced except in full without prior written permission of the company. The test results apply only to the particular sample(s) tested and to the specific tests carried out which is available on request for validation and information confirmed at our website.

Maximum location: X=17.00, Y=-13.00

SAR Peak: 0.91W/kg

SAR 10g (W/Kg)	0.343978
SAR 1g (W/Kg)	0.585699

Z (mm)	0.00	4.00	9.00	14.00	19.00	24.00	29.00
SAR (W/Kg)	0.8861	0.6114	0.3691	0.2241	0.1247	0.0713	0.0434

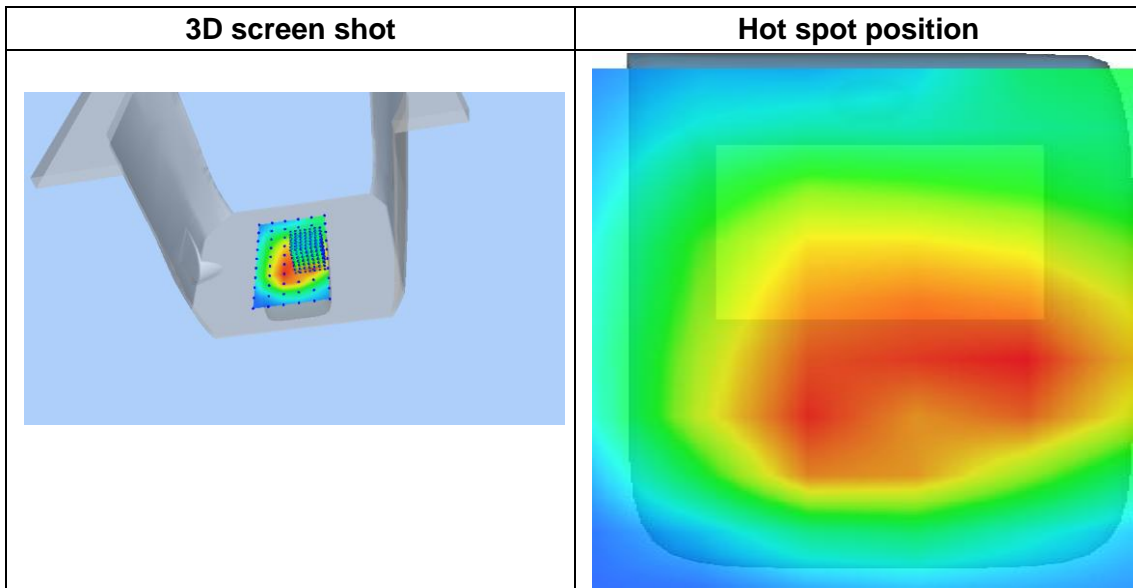
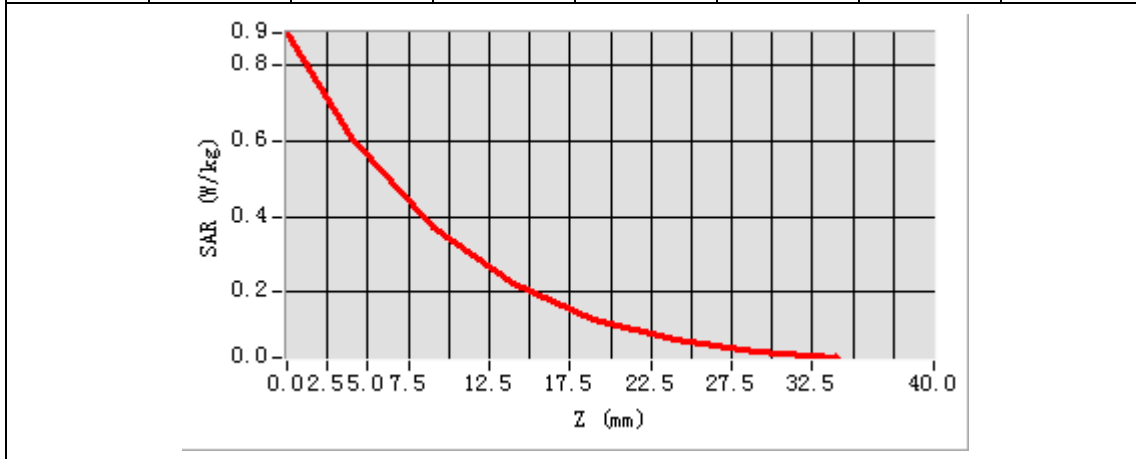

NOTE: This document is issued by MORLAB, the test report shall not be reproduced except in full without prior written permission of the company. The test results apply only to the particular sample(s) tested and to the specific tests carried out which is available on request for validation and information confirmed at our website.

MEASUREMENT 18

Type: Phone measurement (Complete)

Area scan resolution: dx=15mm,dy=15mm

Zoom scan resolution: dx=8mm, dy=8mm, dz=5mm

Date of measurement: 2018.04.05

Measurement duration: 16 minutes 25 seconds

A. Experimental conditions.

<u>Phantom File</u>	<u>surf_sam_plan.txt</u>
<u>Phantom</u>	<u>Flat</u>
<u>Device Position</u>	<u>Body</u>
<u>Band</u>	<u>Band4 WCDMA1700</u>
<u>Channels</u>	<u>Low</u>
<u>Signal</u>	<u>RMC</u>

B. SAR Measurement Results

Lower Band SAR (Channel 1312):

Frequency (MHz)	1712.000000
Relative permittivity (real part)	53.439588
Conductivity (S/m)	1.349644
Power drift (%)	-0.770000
Ambient Temperature:	22.3C
Liquid Temperature:	22.6C
ConvF:	5.38
Crest factor:	1:1

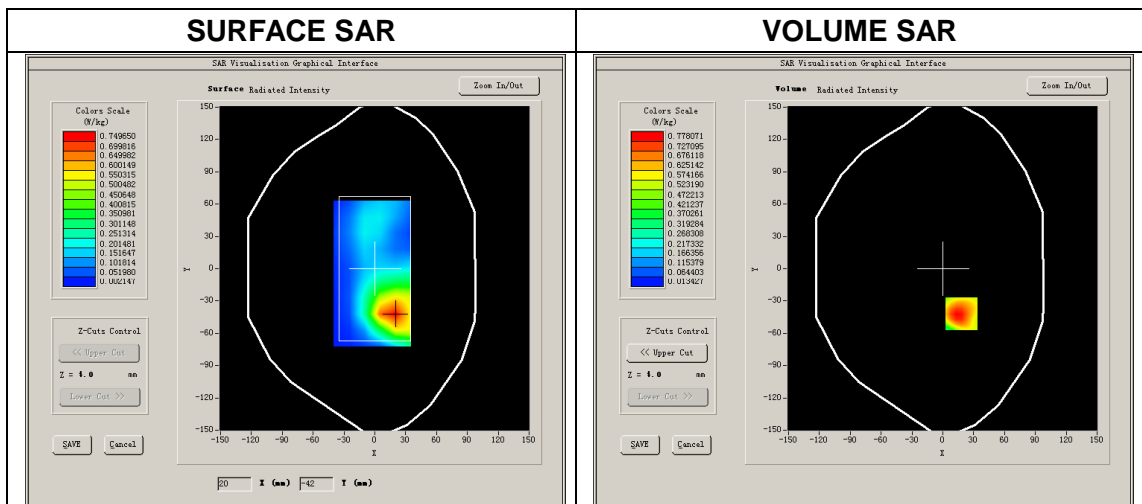

NOTE: This document is issued by MORLAB, the test report shall not be reproduced except in full without prior written permission of the company. The test results apply only to the particular sample(s) tested and to the specific tests carried out which is available on request for validation and information confirmed at our website.

Maximum location: X=18.00, Y=-42.00

SAR Peak: 1.15W/kg

SAR 10g (W/Kg)	0.433605
SAR 1g (W/Kg)	0.741801

Z (mm)	0.00	4.00	9.00	14.00	19.00	24.00	29.00
SAR (W/Kg)	1.2662	0.7781	0.4208	0.2984	0.1632	0.1064	0.0534

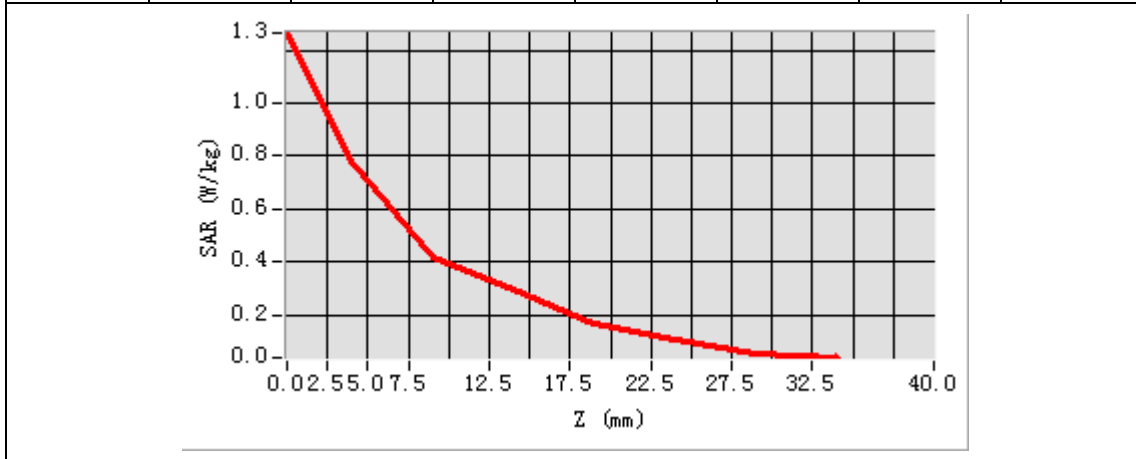

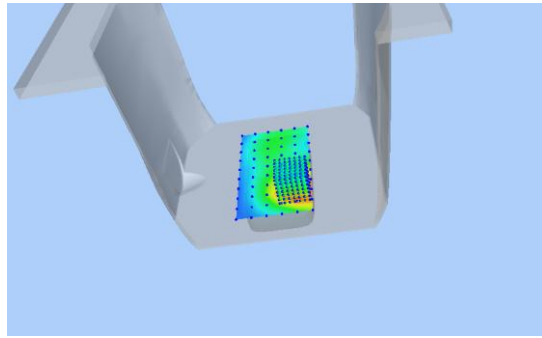
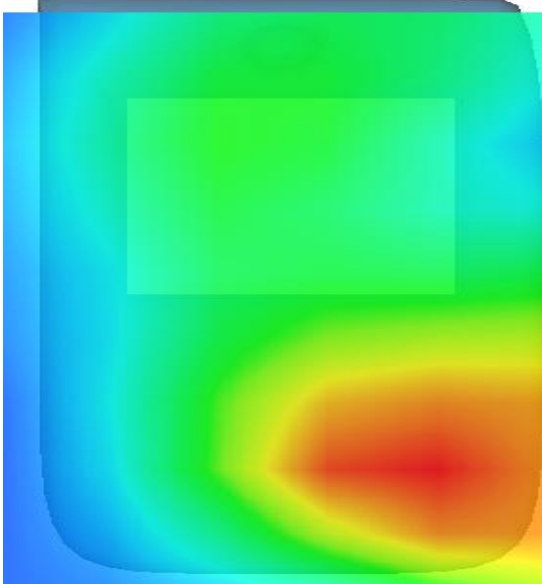
3D screen shot	Hot spot position
	

NOTE: This document is issued by MORLAB, the test report shall not be reproduced except in full without prior written permission of the company. The test results apply only to the particular sample(s) tested and to the specific tests carried out which is available on request for validation and information confirmed at our website.

MEASUREMENT 19

Type: Phone measurement (Complete)

Area scan resolution: dx=15mm,dy=15mm

Zoom scan resolution: dx=8mm, dy=8mm, dz=5mm

Date of measurement: 2018.04.11

Measurement duration: 16 minutes 10 seconds

A. Experimental conditions.

<u>Phantom File</u>	<u>surf_sam_plan.txt</u>
<u>Phantom</u>	<u>Flat</u>
<u>Device Position</u>	<u>Body</u>
<u>Band</u>	<u>Band5_WCDMA850</u>
<u>Channels</u>	<u>Middle</u>
<u>Signal</u>	<u>RMC</u>

B. SAR Measurement Results

Middle Band SAR (Channel 4182):

Frequency (MHz)	836.400024
Relative permittivity (real part)	55.34528
Conductivity (S/m)	0.901453
Power drift (%)	1.460000
Ambient Temperature:	22.6°C
Liquid Temperature:	21.2°C
ConvF:	6.37
Crest factor:	1:1

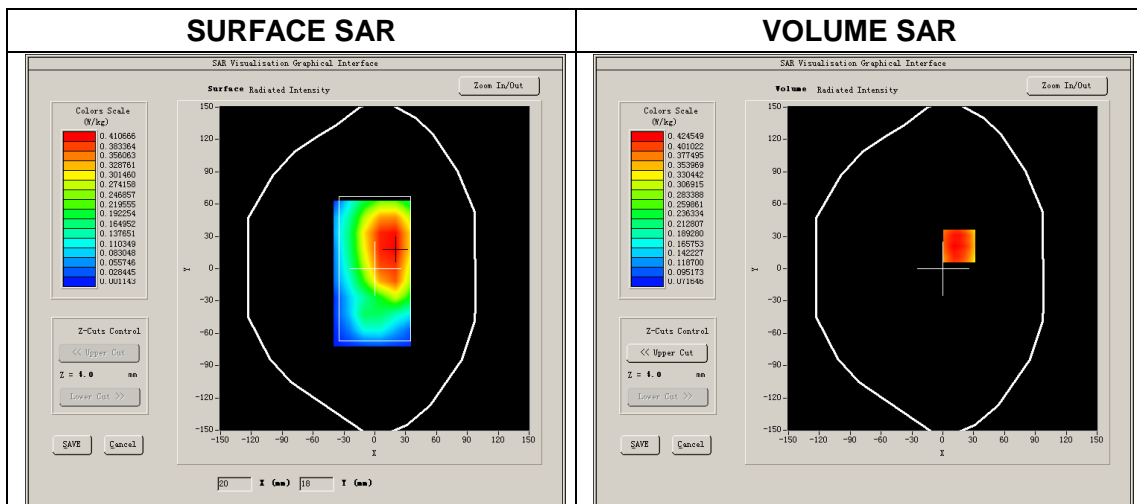

NOTE: This document is issued by MORLAB, the test report shall not be reproduced except in full without prior written permission of the company. The test results apply only to the particular sample(s) tested and to the specific tests carried out which is available on request for validation and information confirmed at our website.

Maximum location: X=16.00, Y=21.00

SAR Peak: 0.52W/kg

SAR 10g (W/Kg)	0.309701
SAR 1g (W/Kg)	0.409353

Z (mm)	0.00	4.00	9.00	14.00	19.00	24.00	29.00
SAR (W/Kg)	0.5579	0.4245	0.3120	0.2651	0.1942	0.1617	0.1206

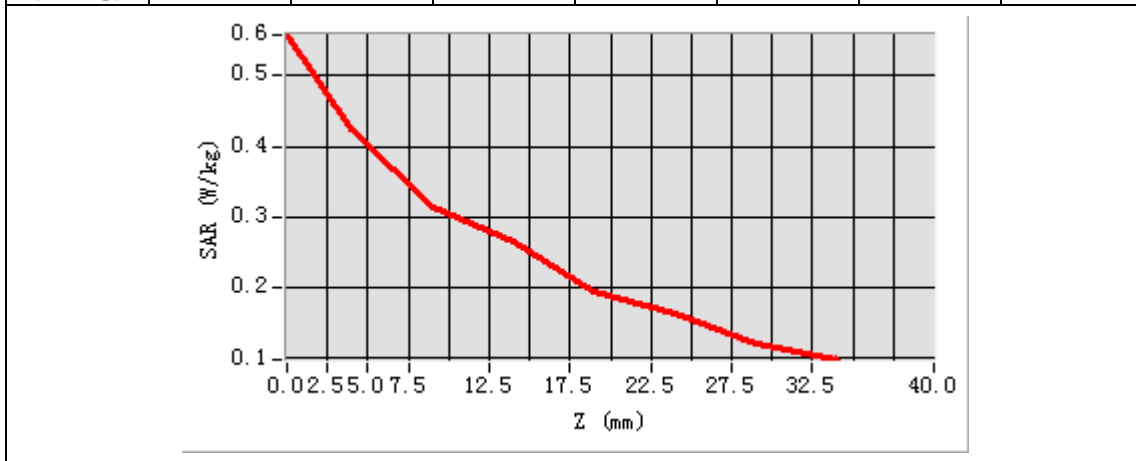

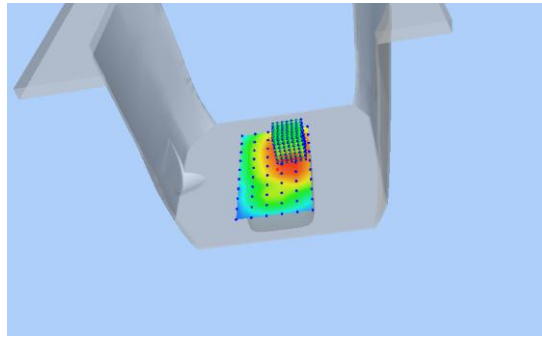
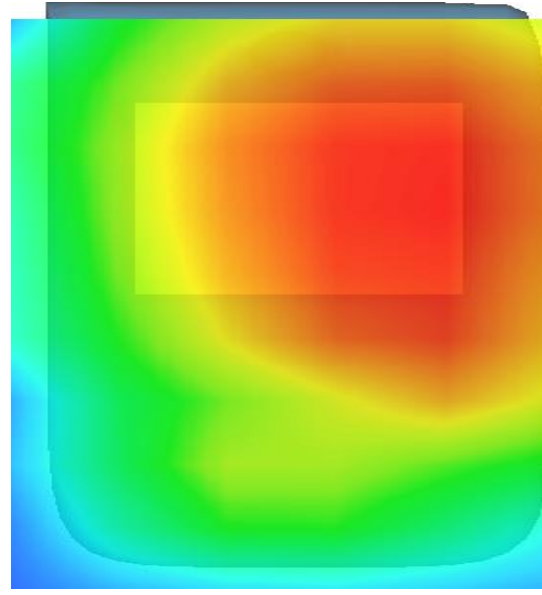
3D screen shot	Hot spot position
	

NOTE: This document is issued by MORLAB, the test report shall not be reproduced except in full without prior written permission of the company. The test results apply only to the particular sample(s) tested and to the specific tests carried out which is available on request for validation and information confirmed at our website.

MEASUREMENT 20

Type: Phone measurement (Complete)

Area scan resolution: dx=15mm,dy=15mm

Zoom scan resolution: dx=8mm, dy=8mm, dz=5mm

Date of measurement: 2018.04.10

Measurement duration: 16 minutes 39 seconds

A. Experimental conditions.

<u>Phantom File</u>	<u>surf_sam_plan.txt</u>
<u>Phantom</u>	<u>Flat</u>
<u>Device Position</u>	<u>Body</u>
<u>Band</u>	<u>LTE band 2</u>
<u>Channels</u>	<u>Middle</u>
<u>Signal</u>	<u>LTE</u>

B. SAR Measurement Results

Middle Band SAR (Channel 18900):

Frequency (MHz)	1879.500000
Relative permittivity (real part)	53.338999
Conductivity (S/m)	1.520724
Power drift (%)	-0.230000
Ambient Temperature:	22.1°C
Liquid Temperature:	22.4°C
ConvF:	5.71
Duty cycle:	1:1

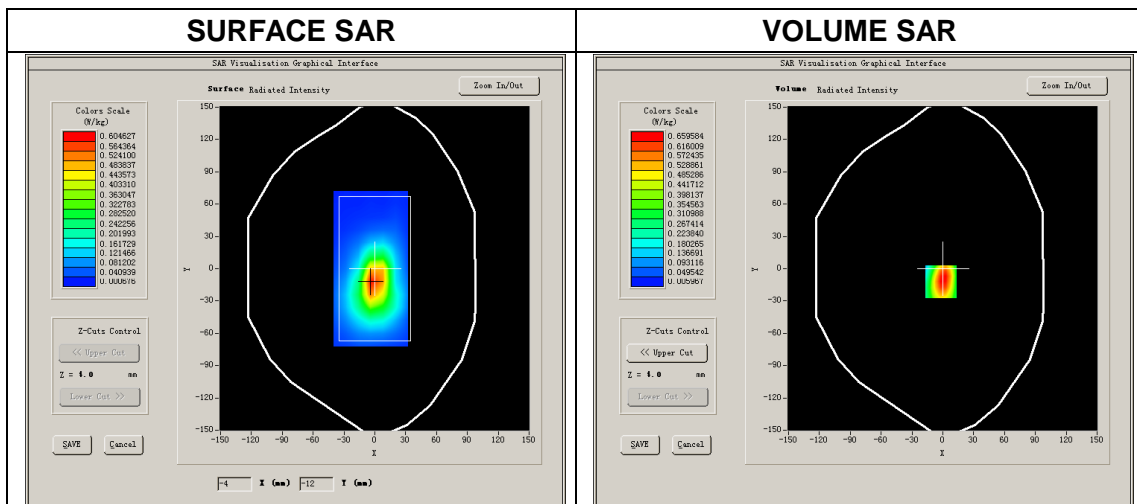

NOTE: This document is issued by MORLAB, the test report shall not be reproduced except in full without prior written permission of the company. The test results apply only to the particular sample(s) tested and to the specific tests carried out which is available on request for validation and information confirmed at our website.

Maximum location: X=-2.00, Y=-12.00

SAR Peak: 1.03W/kg

SAR 10g (W/Kg)	0.324505
SAR 1g (W/Kg)	0.624832

Z (mm)	0.00	4.00	9.00	14.00	19.00	24.00	29.00
SAR (W/Kg)	1.1983	0.6596	0.2955	0.2161	0.1036	0.0671	0.0253

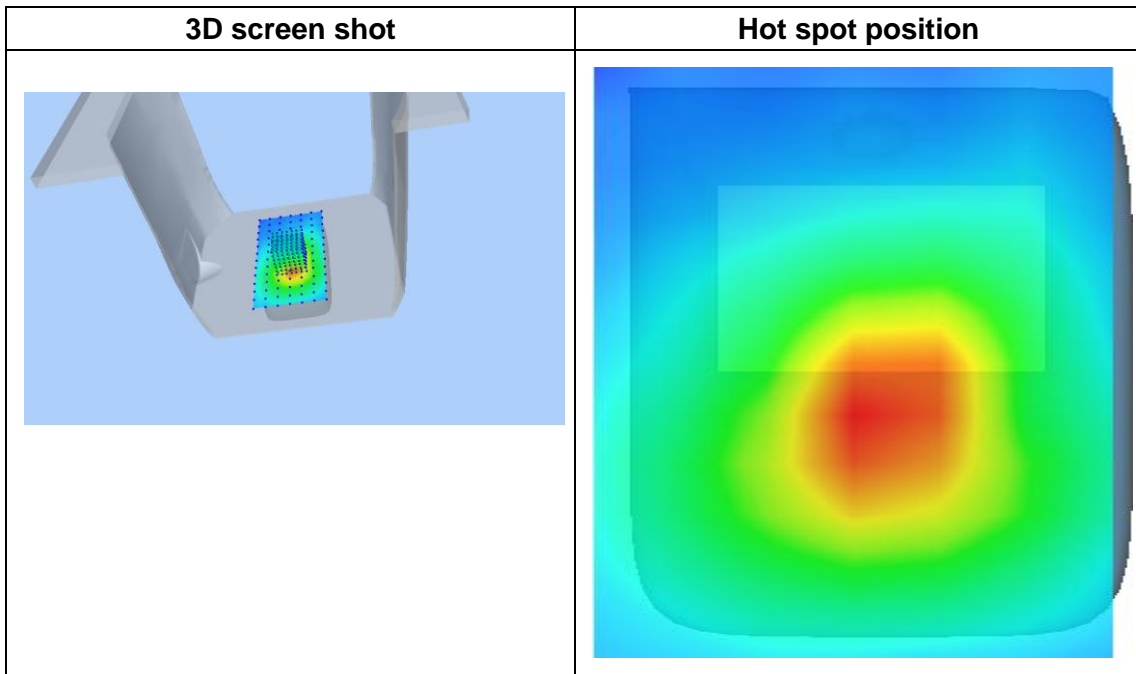
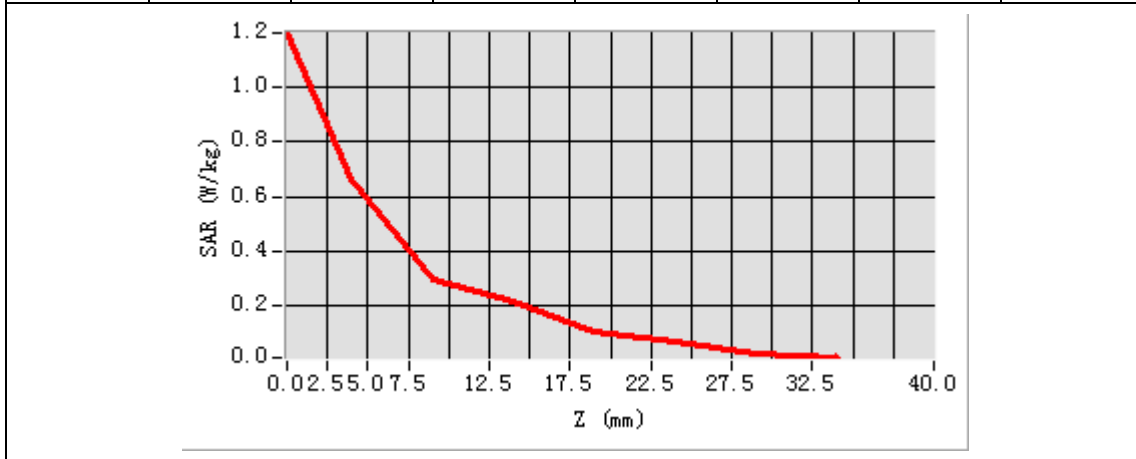

NOTE: This document is issued by MORLAB, the test report shall not be reproduced except in full without prior written permission of the company. The test results apply only to the particular sample(s) tested and to the specific tests carried out which is available on request for validation and information confirmed at our website.

MEASUREMENT 21

Type: Phone measurement (Complete)

Area scan resolution: dx=15mm,dy=15mm

Zoom scan resolution: dx=8mm, dy=8mm, dz=5mm

Date of measurement: 2018.04.05

Measurement duration: 10 minutes 2 seconds

A. Experimental conditions.

<u>Phantom File</u>	<u>surf_sam_plan.txt</u>
<u>Phantom</u>	<u>Flat</u>
<u>Device Position</u>	<u>Body</u>
<u>Band</u>	<u>LTE band 4</u>
<u>Channels</u>	<u>Low</u>
<u>Signal</u>	<u>LTE</u>

B. SAR Measurement Results

Higher Band SAR (Channel 20050):

Frequency (MHz)	1719.500000
Relative permittivity (real part)	53.538841
Conductivity (S/m)	1.460235
Power drift (%)	-0.280000
Ambient Temperature:	22.2°C
Liquid Temperature:	22.6°C
ConvF:	5.38
Crest factor:	1:1

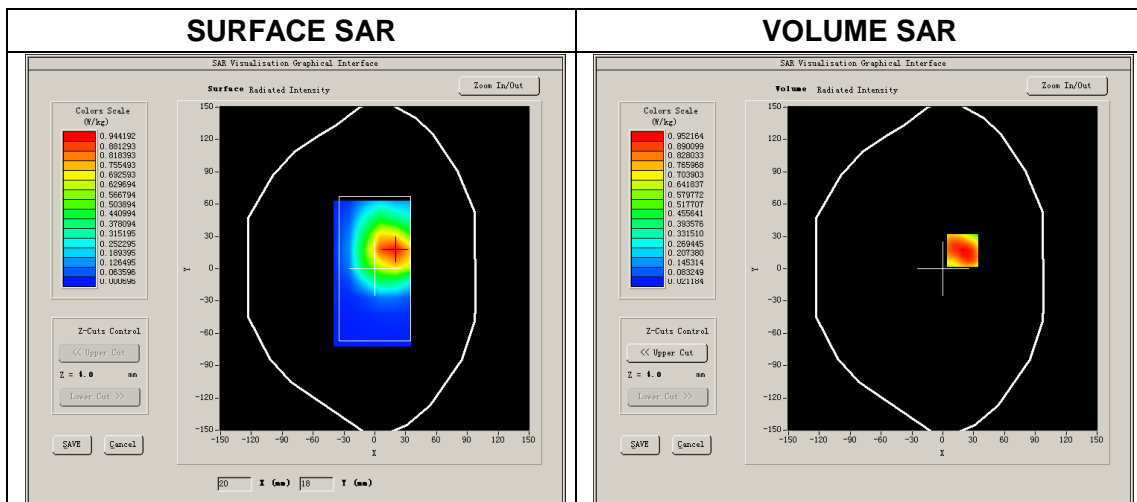

NOTE: This document is issued by MORLAB, the test report shall not be reproduced except in full without prior written permission of the company. The test results apply only to the particular sample(s) tested and to the specific tests carried out which is available on request for validation and information confirmed at our website.

Maximum location: X=19.00, Y=17.00

SAR Peak: 1.42W/kg

SAR 10g (W/Kg)	0.546895
SAR 1g (W/Kg)	0.910831

Z (mm)	0.00	4.00	9.00	14.00	19.00	24.00	29.00
SAR (W/Kg)	1.4204	0.9522	0.5694	0.3482	0.2059	0.1255	0.0676

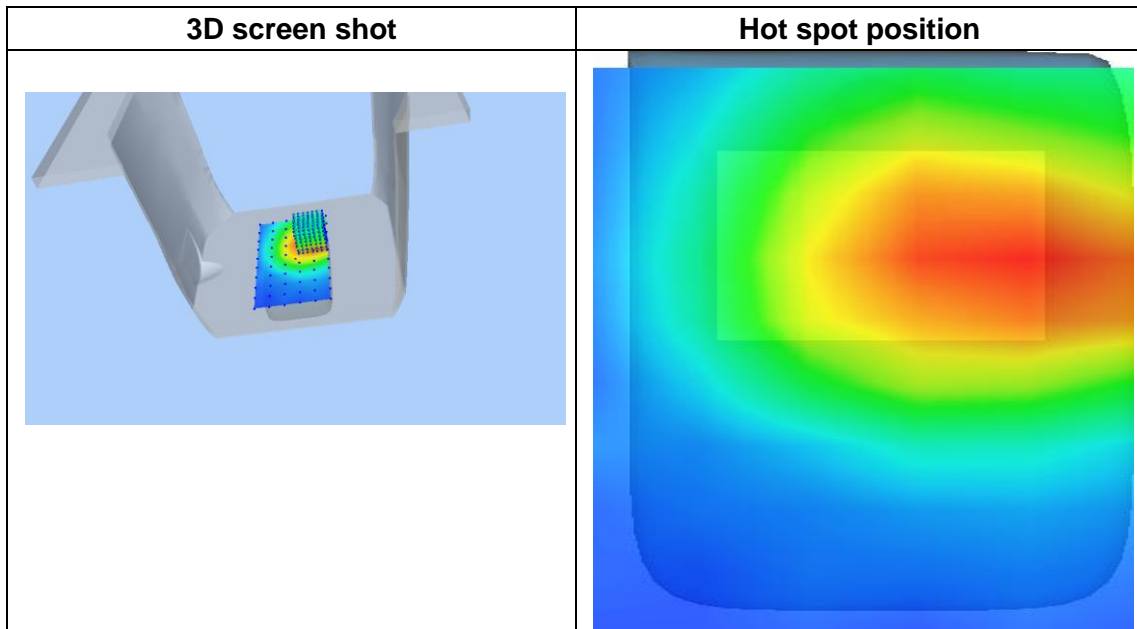
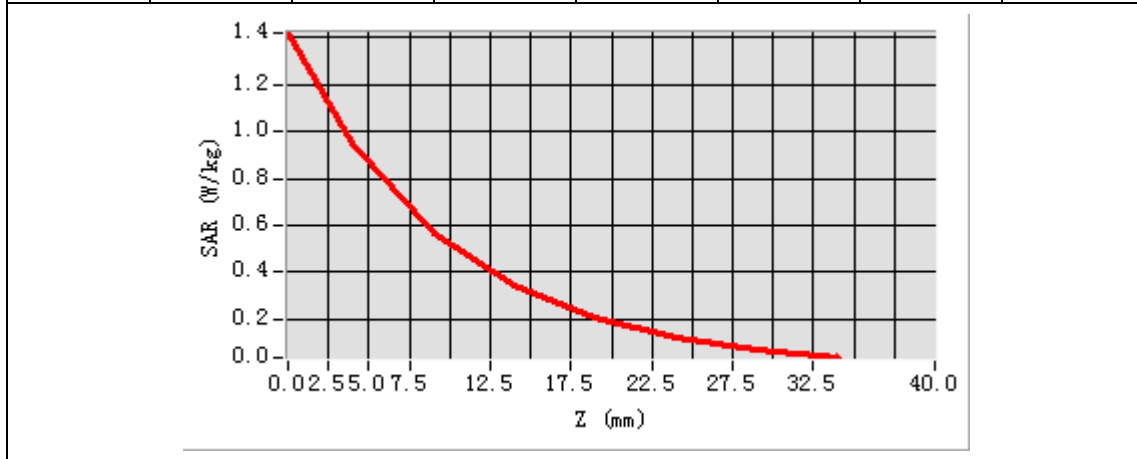

NOTE: This document is issued by MORLAB, the test report shall not be reproduced except in full without prior written permission of the company. The test results apply only to the particular sample(s) tested and to the specific tests carried out which is available on request for validation and information confirmed at our website.

MEASUREMENT 22

Type: Phone measurement (Complete)

Area scan resolution: dx=15mm,dy=15mm

Zoom scan resolution: dx=8mm, dy=8mm, dz=5mm

Date of measurement: 2018.04.05

Measurement duration: 16 minutes 56 seconds

A. Experimental conditions.

<u>Phantom File</u>	<u>surf_sam_plan.txt</u>
<u>Phantom</u>	<u>Flat</u>
<u>Device Position</u>	<u>Body</u>
<u>Band</u>	<u>LTE band 12</u>
<u>Channels</u>	<u>Middle</u>
<u>Signal</u>	<u>LTE</u>

B. SAR Measurement Results

Middle Band SAR (Channel 23095):

Frequency (MHz)	707.500000
Relative permittivity (real part)	55.696754
Conductivity (S/m)	1.039129
Power drift (%)	-2.950000
Ambient Temperature:	22.6°C
Liquid Temperature:	21.2°C
ConvF:	6.68
Crest factor:	1:1

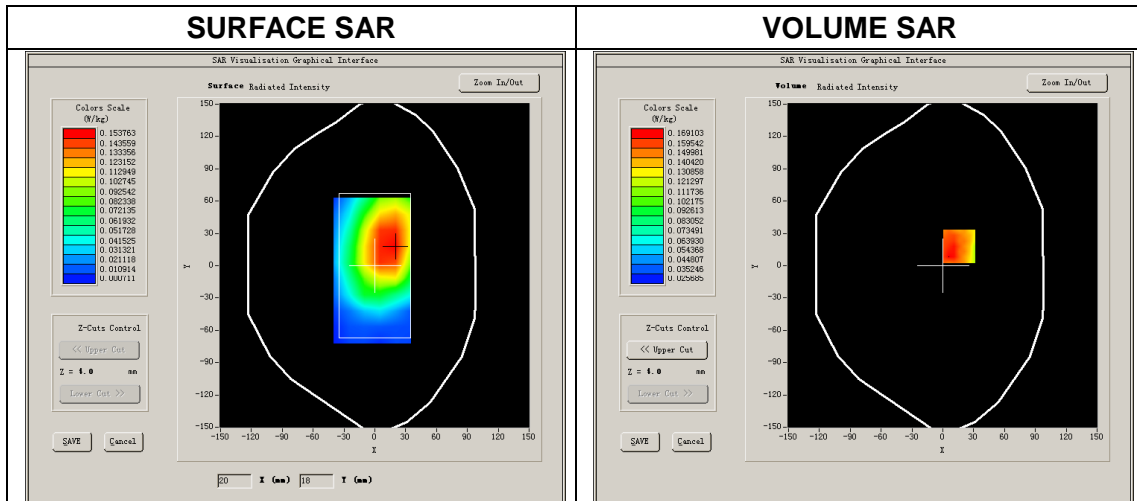

NOTE: This document is issued by MORLAB, the test report shall not be reproduced except in full without prior written permission of the company. The test results apply only to the particular sample(s) tested and to the specific tests carried out which is available on request for validation and information confirmed at our website.

Maximum location: X=16.00, Y=18.00

SAR Peak: 0.22W/kg

SAR 10g (W/Kg)	0.126708
SAR 1g (W/Kg)	0.171033

Z (mm)	0.00	4.00	9.00	14.00	19.00	24.00	29.00
SAR (W/Kg)	0.2522	0.1691	0.1110	0.1011	0.0711	0.0625	0.0426

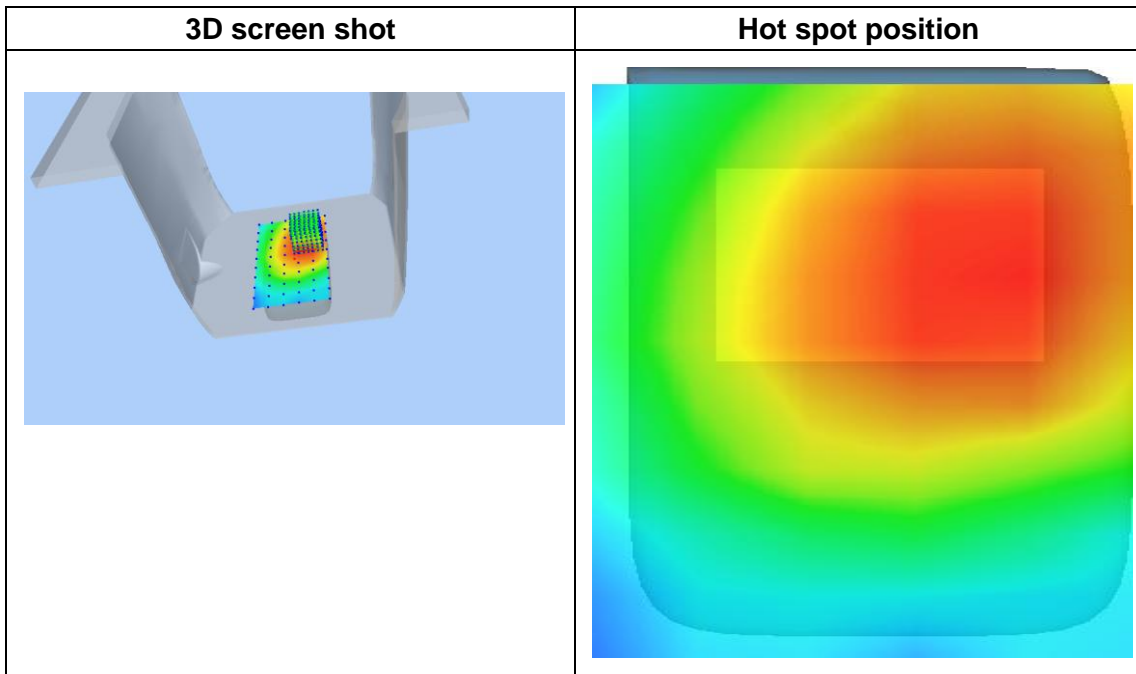
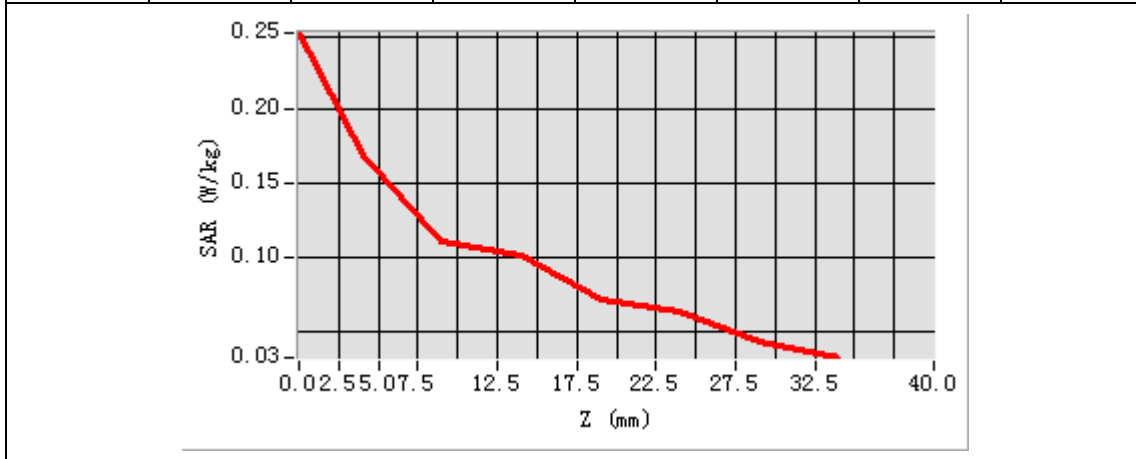

NOTE: This document is issued by MORLAB, the test report shall not be reproduced except in full without prior written permission of the company. The test results apply only to the particular sample(s) tested and to the specific tests carried out which is available on request for validation and information confirmed at our website.



MEASUREMENT 23

Type: Phone measurement (Complete)
 Area scan resolution: dx=15mm,dy=15mm
 Zoom scan resolution: dx=8mm, dy=8mm, dz=5mm
 Date of measurement: 2018.04.05
 Measurement duration: 16 minutes 8 seconds

A. Experimental conditions.

Phantom File	surf_sam_plan.txt
Phantom	Flat
Device Position	Body
Band	LTE band 17
Channels	High
Signal	LTE

B. SAR Measurement Results

Higher Band SAR (Channel 23800):

Frequency (MHz)	711.000000
Relative permittivity (real part)	55.663117
Conductivity (S/m)	1.038276
Power drift (%)	4.000000
Ambient Temperature:	22.6°C
Liquid Temperature:	21.2°C
ConvF:	6.68
Crest factor:	1:1

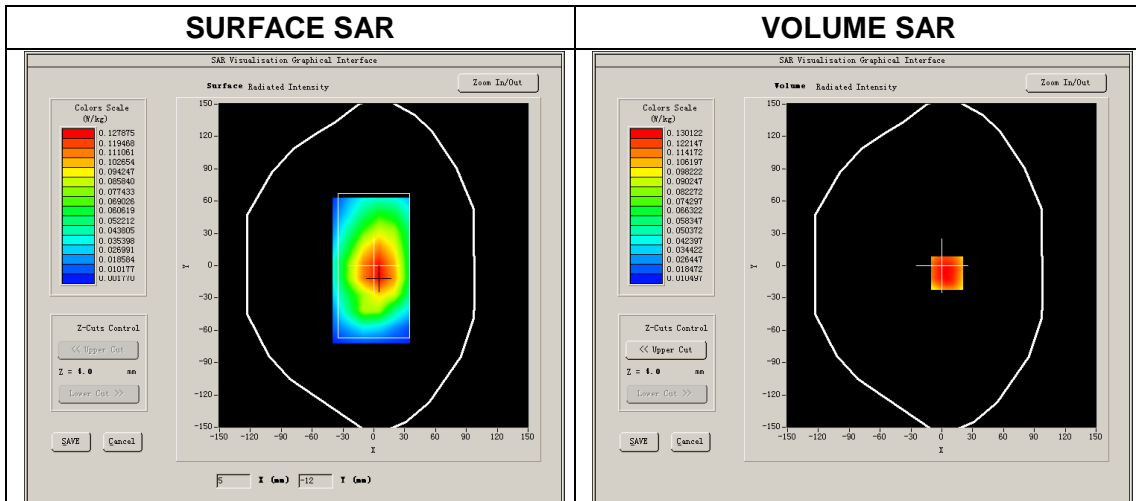

NOTE: This document is issued by MORLAB, the test report shall not be reproduced except in full without prior written permission of the company. The test results apply only to the particular sample(s) tested and to the specific tests carried out which is available on request for validation and information confirmed at our website.

Maximum location: X=5.00, Y=-7.00

SAR Peak: 0.17W/kg

SAR 10g (W/Kg)	0.097361
SAR 1g (W/Kg)	0.134063

Z (mm)	0.00	4.00	9.00	14.00	19.00	24.00	29.00
SAR (W/Kg)	0.1531	0.1301	0.1019	0.0746	0.0605	0.0387	0.0322

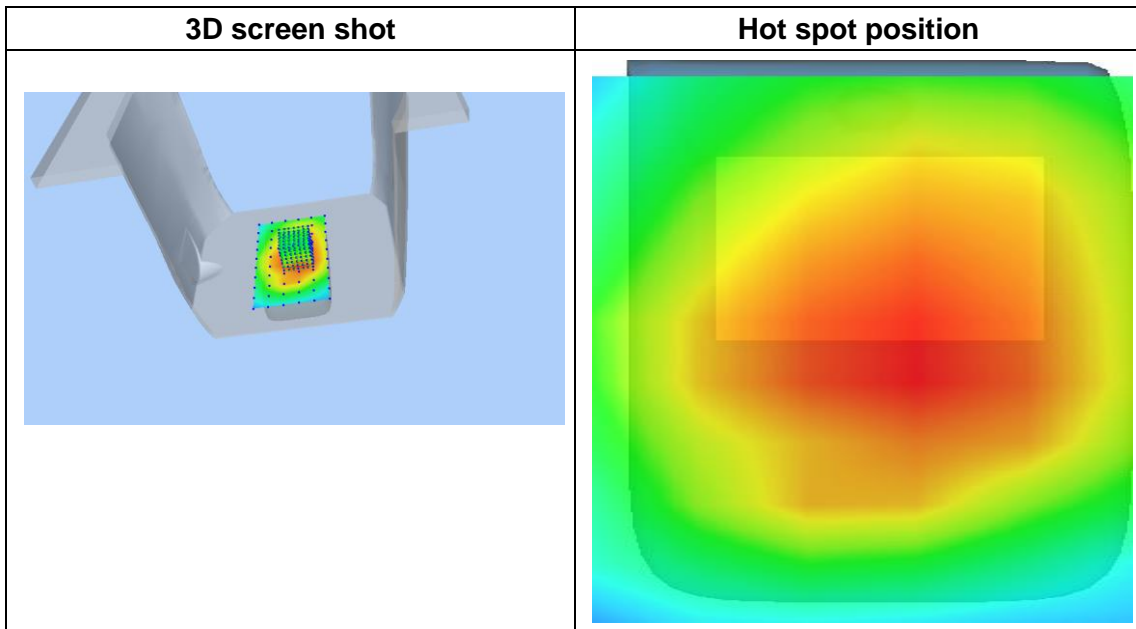
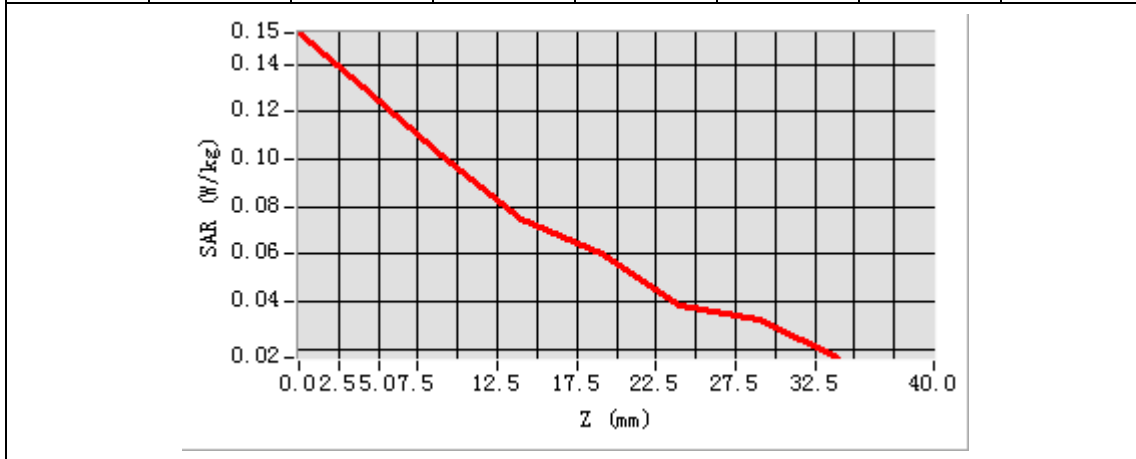

NOTE: This document is issued by MORLAB, the test report shall not be reproduced except in full without prior written permission of the company. The test results apply only to the particular sample(s) tested and to the specific tests carried out which is available on request for validation and information confirmed at our website.

MEASUREMENT 24

Type: Phone measurement (Complete)

Area scan resolution: dx=12mm,dy=12mm

Zoom scan resolution: dx=5mm, dy=5mm, dz=4mm

Date of measurement: 2018.04.17

Measurement duration: 18 minutes 53 seconds

A. Experimental conditions.

<u>Phantom File</u>	<u>surf_sam_plan.txt</u>
<u>Phantom</u>	<u>Flat</u>
<u>Device Position</u>	<u>Body</u>
<u>Band</u>	<u>IEEE 802.11b ISM</u>
<u>Channels</u>	<u>Middle</u>
<u>Signal</u>	<u>DSSS</u>

B. SAR Measurement Results

Middle Band SAR (Channel 6):

Frequency (MHz)	2437.000000
Relative permittivity (real part)	52.717335
Conductivity (S/m)	1.937580
Power Drift (%)	-2.200000
Ambient Temperature:	22.0°C
Liquid Temperature:	21.8°C
ConvF:	4.93
Crest factor:	1:1

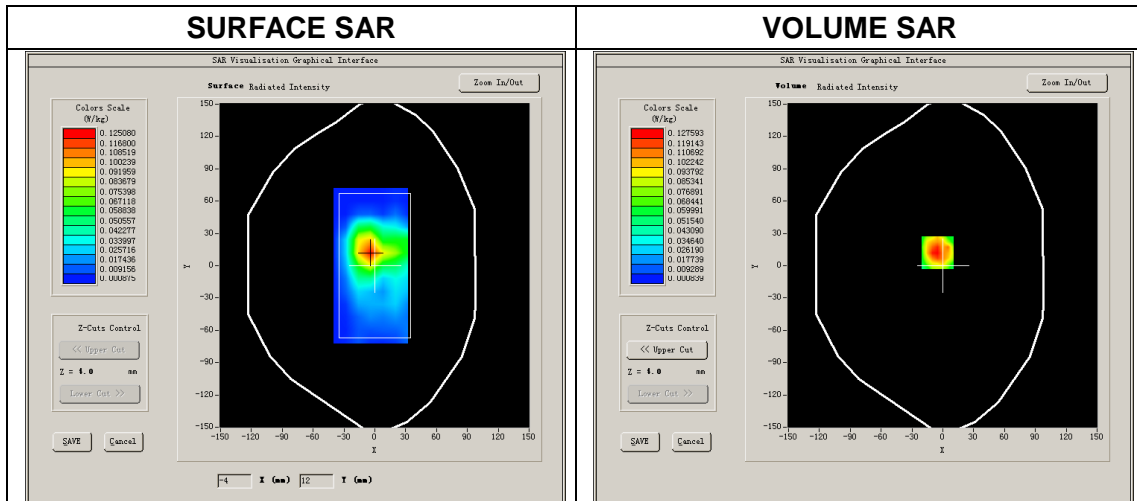

NOTE: This document is issued by MORLAB, the test report shall not be reproduced except in full without prior written permission of the company. The test results apply only to the particular sample(s) tested and to the specific tests carried out which is available on request for validation and information confirmed at our website.

Maximum location: X=-5.00, Y=12.00

SAR Peak: 0.23W/kg

SAR 10g (W/Kg)	0.055008
SAR 1g (W/Kg)	0.114357

Z (mm)	0.00	4.00	8.00	12.00	16.00	20.00	24.00	28.00
SAR (W/Kg)	0.2231	0.1276	0.0658	0.0335	0.0109	0.0049	0.0035	0.0012

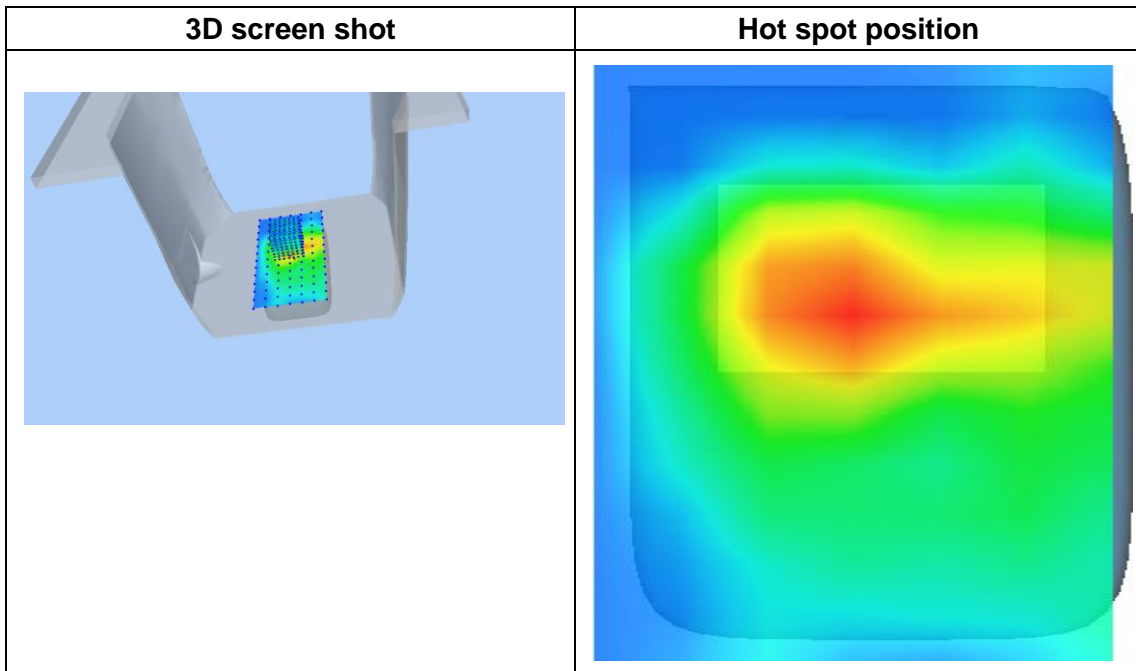
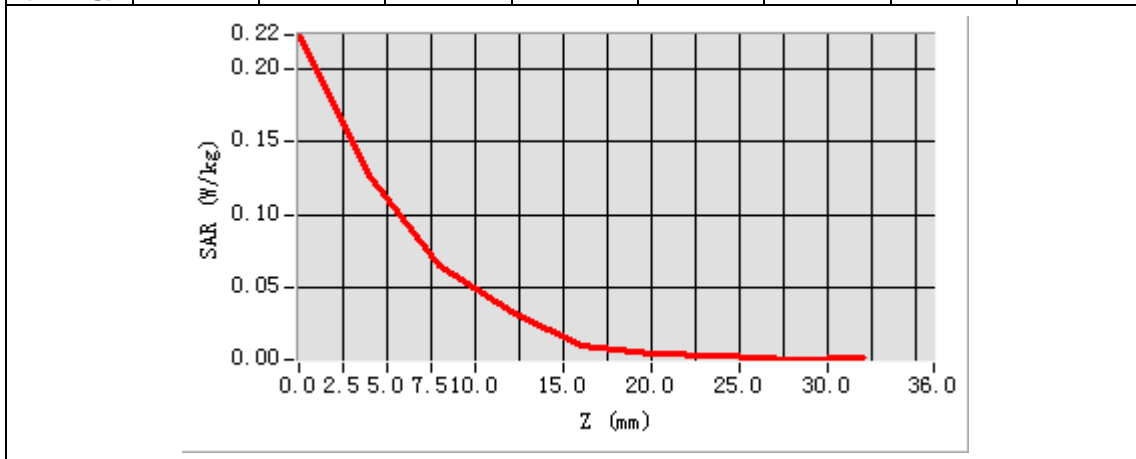

NOTE: This document is issued by MORLAB, the test report shall not be reproduced except in full without prior written permission of the company. The test results apply only to the particular sample(s) tested and to the specific tests carried out which is available on request for validation and information confirmed at our website.

MEASUREMENT 25

Type: Phone measurement (Complete)

Area scan resolution: dx=10mm,dy=10mm

Zoom scan resolution: dx=4mm, dy=4mm, dz=2mm

Date of measurement: 2018.04.16

Measurement duration: 27 minutes 6 seconds

A. Experimental conditions.

Phantom File	surf_sam_plan.txt
Phantom	Flat
Device Position	Body
Band	IEEE 802.11a U-NII
Channels	High
Signal	OFDM

B. SAR Measurement Results

Higher Band SAR (Channel 48):

Frequency (MHz)	5240.000000
Relative permittivity (real part)	48.359999
Conductivity (S/m)	4.799698
Power Drift (%)	1.510002
Ambient Temperature:	22.9°C
Liquid Temperature:	22.1°C
ConvF:	22.11
Crest factor:	1:1

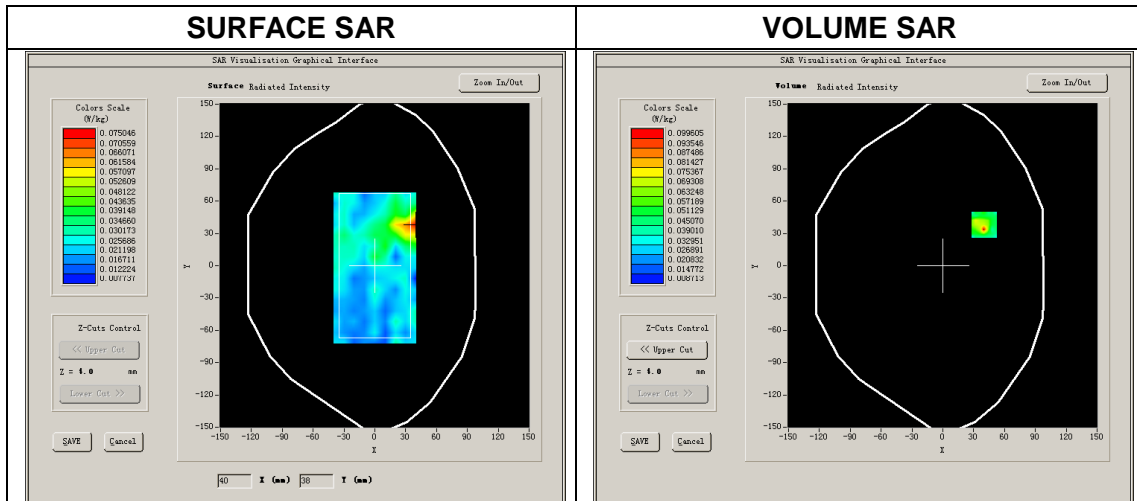

NOTE: This document is issued by MORLAB, the test report shall not be reproduced except in full without prior written permission of the company. The test results apply only to the particular sample(s) tested and to the specific tests carried out which is available on request for validation and information confirmed at our website.

Maximum location: X=40.00, Y=38.00

SAR Peak: 0.34W/kg

SAR 10g (W/Kg)	0.047294
SAR 1g (W/Kg)	0.084082

Z (m m)	0.00	4.00	6.00	8.00	10.0	12.0	14.0	16.0	18.0	20.0	22.0	24.0
SA R (W/ Kg)	0.2671	0.0996	0.0440	0.0356	0.0246	0.0256	0.0226	0.0182	0.0195	0.0252	0.0119	0.0227

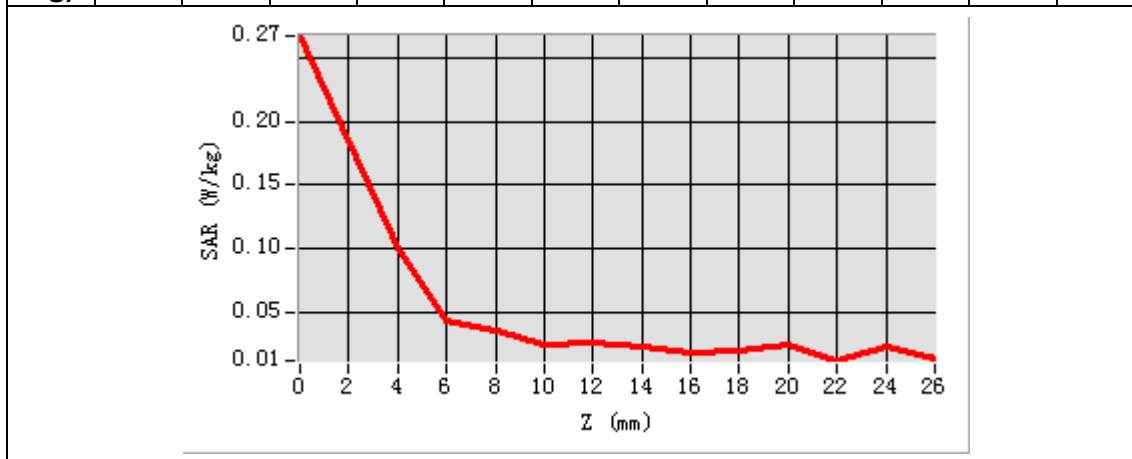

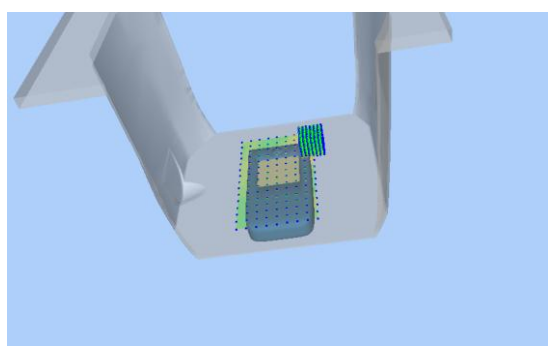
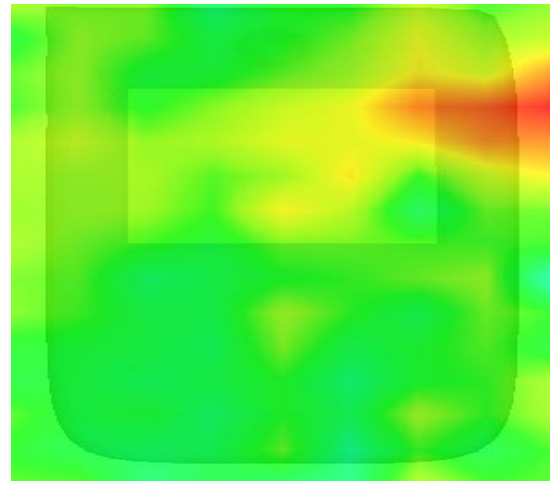
3D screen shot	Hot spot position
	

NOTE: This document is issued by MORLAB, the test report shall not be reproduced except in full without prior written permission of the company. The test results apply only to the particular sample(s) tested and to the specific tests carried out which is available on request for validation and information confirmed at our website.

MEASUREMENT 26

Type: Phone measurement (Complete)

Area scan resolution: dx=10mm,dy=10mm

Zoom scan resolution: dx=4mm, dy=4mm, dz=2mm

Date of measurement: 2018.04.16

Measurement duration: 27 minutes 8 seconds

A. Experimental conditions.

Phantom File	surf_sam_plan.txt
Phantom	Flat
Device Position	Body
Band	IEEE 802.11a U-NII
Channels	Middle
Signal	OFDM

B. SAR Measurement Results

Middle Band SAR (Channel 60):

Frequency (MHz)	5300.000000
Relative permittivity (real part)	48.260002
Conductivity (S/m)	5.459694
Power Drift (%)	3.710000
Ambient Temperature:	22.9°C
Liquid Temperature:	22.1°C
ConvF:	22.11
Crest factor:	1:1

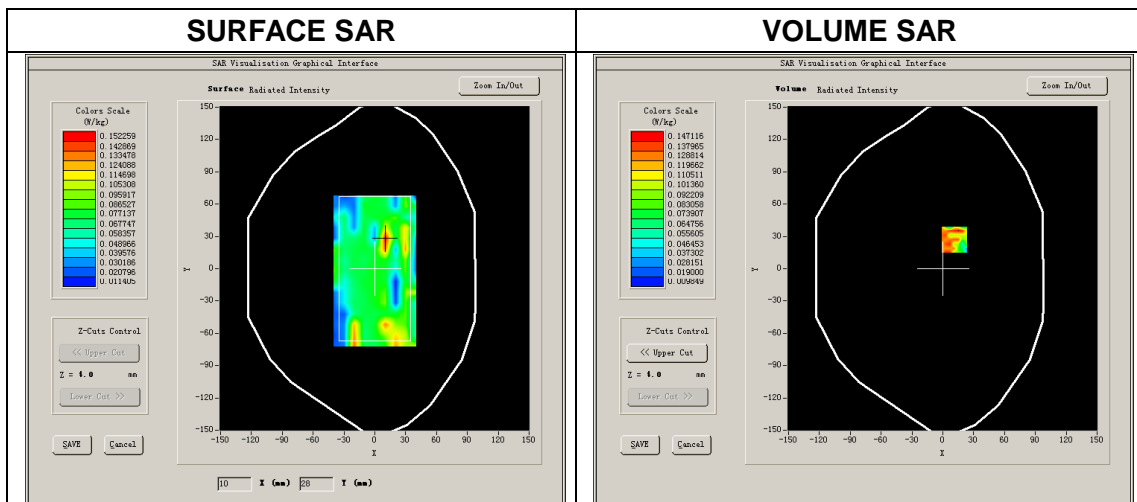

NOTE: This document is issued by MORLAB, the test report shall not be reproduced except in full without prior written permission of the company. The test results apply only to the particular sample(s) tested and to the specific tests carried out which is available on request for validation and information confirmed at our website.

Maximum location: X=11.00, Y=27.00

SAR Peak: 0.42W/kg

SAR 10g (W/Kg)	0.103144
SAR 1g (W/Kg)	0.146335

Z (m m)	0.00	4.00	6.00	8.00	10.0	12.0	14.0	16.0	18.0	20.0	22.0	24.0
SA R (W/ Kg)	0.1583	0.1471	0.1313	0.1187	0.0834	0.0623	0.0654	0.0611	0.0529	0.0614	0.0610	0.0482

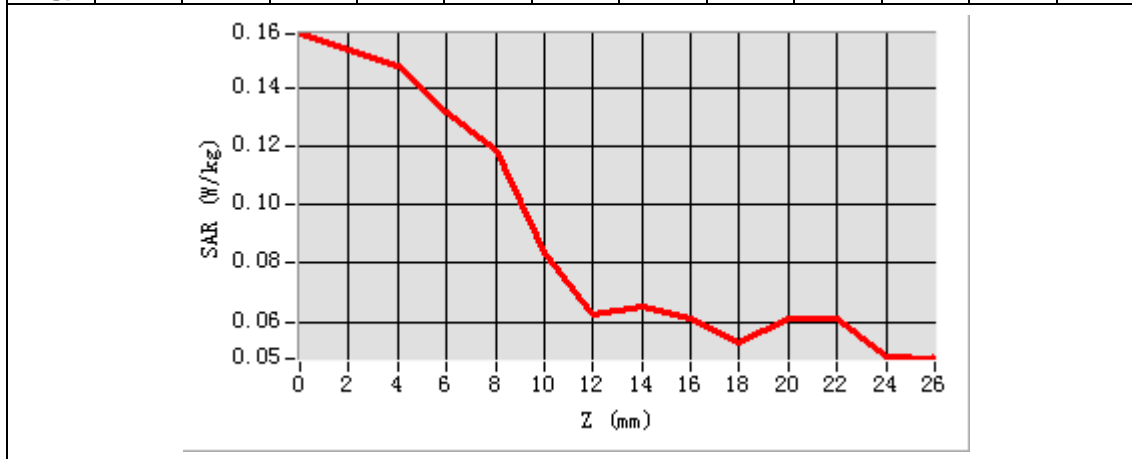

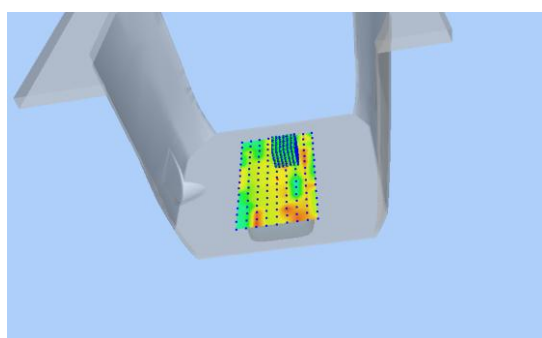
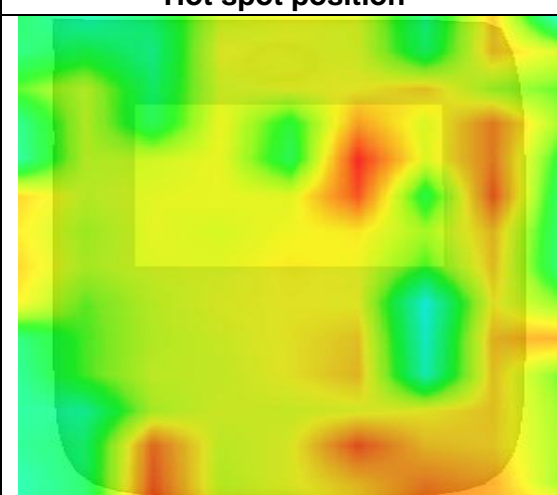
3D screen shot	Hot spot position
	

NOTE: This document is issued by MORLAB, the test report shall not be reproduced except in full without prior written permission of the company. The test results apply only to the particular sample(s) tested and to the specific tests carried out which is available on request for validation and information confirmed at our website.

MEASUREMENT 27

Type: Phone measurement (Complete)

Area scan resolution: dx=10mm,dy=10mm

Zoom scan resolution: dx=4mm, dy=4mm, dz=2mm

Date of measurement: 2018.04.16

Measurement duration: 27 minutes 6 seconds

A. Experimental conditions.

Phantom File	surf_sam_plan.txt
Phantom	Flat
Device Position	Body
Band	IEEE 802.11a U-NII
Channels	Middle
Signal	OFDM

B. SAR Measurement Results

Middle Band SAR (Channel 120):

Frequency (MHz)	5600.000000
Relative permittivity (real part)	48.394381
Conductivity (S/m)	5.7432600
Power Drift (%)	2.740000
Ambient Temperature:	22.9°C
Liquid Temperature:	22.1°C
ConvF:	23.02
Crest factor:	1:1

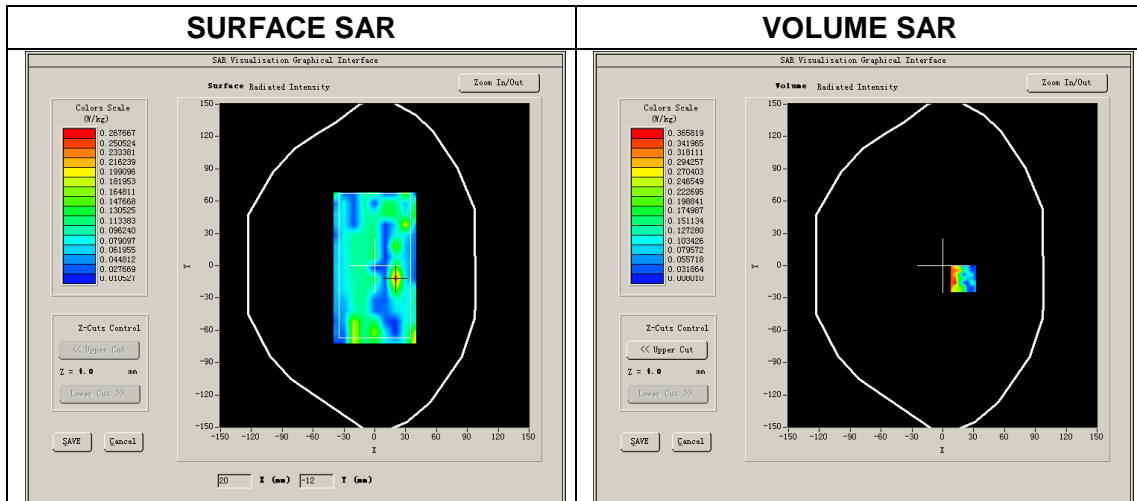

NOTE: This document is issued by MORLAB, the test report shall not be reproduced except in full without prior written permission of the company. The test results apply only to the particular sample(s) tested and to the specific tests carried out which is available on request for validation and information confirmed at our website.

Maximum location: X=20.00, Y=-12.00

SAR Peak: 0.83W/kg

SAR 10g (W/Kg)	0.131294
SAR 1g (W/Kg)	0.245391

Z (m m)	0.00	4.00	6.00	8.00	10.0	12.0	14.0	16.0	18.0	20.0	22.0	24.0
SA R (W/ Kg)	0.8880	0.3658	0.0194	0.3551	0.0284	0.1127	0.0980	0.0934	0.1239	0.0818	0.0546	0.0337

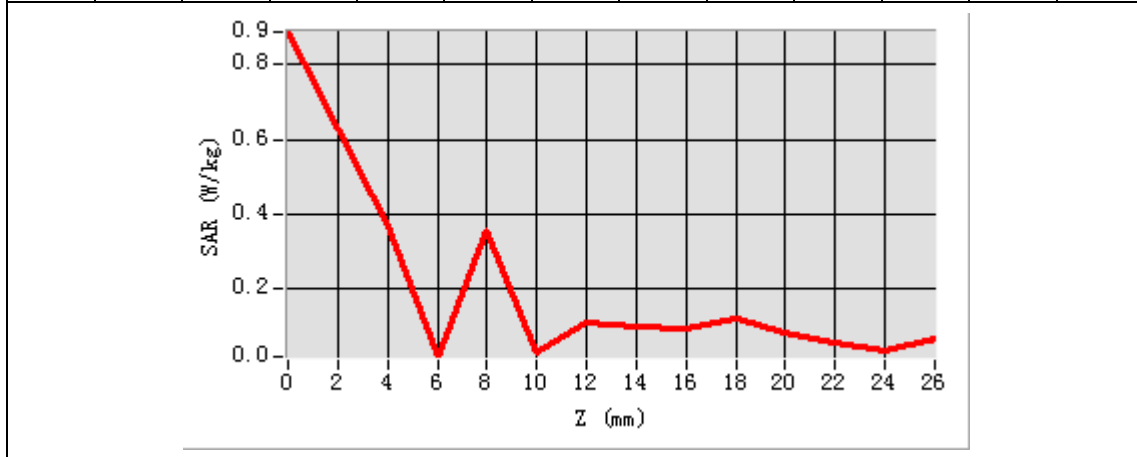

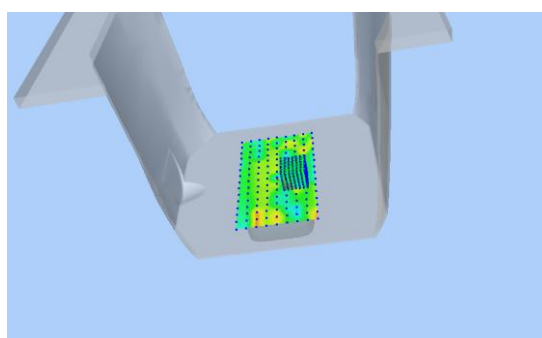
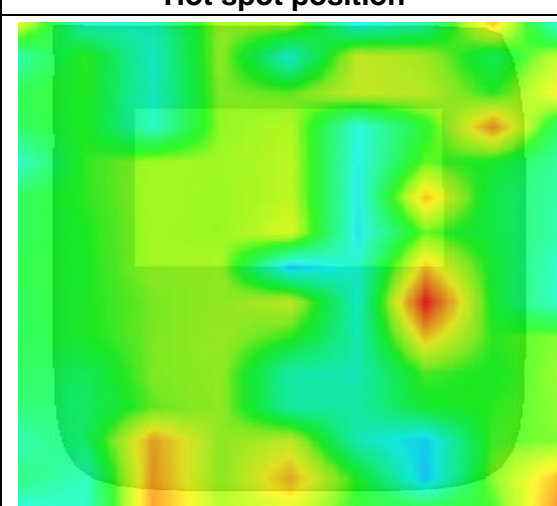
3D screen shot	Hot spot position
	

NOTE: This document is issued by MORLAB, the test report shall not be reproduced except in full without prior written permission of the company. The test results apply only to the particular sample(s) tested and to the specific tests carried out which is available on request for validation and information confirmed at our website.

MEASUREMENT 28

Type: Phone measurement (Complete)

Area scan resolution: dx=10mm,dy=10mm

Zoom scan resolution: dx=4mm, dy=4mm, dz=2mm

Date of measurement: 2018.04.16

Measurement duration: 27 minutes 18 seconds

A. Experimental conditions.

<u>Phantom File</u>	<u>surf_sam_plan.txt</u>
<u>Phantom</u>	<u>Flat</u>
<u>Device Position</u>	<u>Body</u>
<u>Band</u>	<u>IEEE 802.11a U-NII</u>
<u>Channels</u>	<u>High</u>
<u>Signal</u>	<u>OFDM</u>

B. SAR Measurement Results

Higher Band SAR (Channel 159):

Frequency (MHz)	5795.000000
Relative permittivity (real part)	48.005000
Conductivity (S/m)	5.786528
Power Drift (%)	2.900002
Ambient Temperature:	22.9°C
Liquid Temperature:	22.1°C
ConvF:	23.02
Crest factor:	1:1

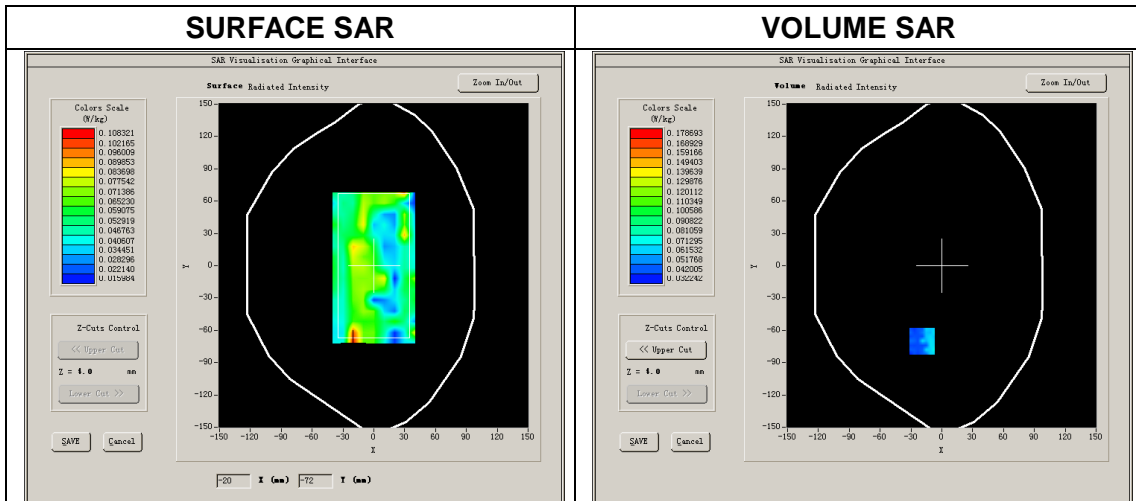

NOTE: This document is issued by MORLAB, the test report shall not be reproduced except in full without prior written permission of the company. The test results apply only to the particular sample(s) tested and to the specific tests carried out which is available on request for validation and information confirmed at our website.

Maximum location: X=-19.00, Y=-70.00

SAR Peak: 0.37W/kg

SAR 10g (W/Kg)	0.085262
SAR 1g (W/Kg)	0.113628

Z (m m)	0.00	4.00	6.00	8.00	10.0	12.0	14.0	16.0	18.0	20.0	22.0	24.0
SA R (W/ Kg)	0.1452	0.0715	0.0406	0.0587	0.0375	0.0373	0.0398	0.1544	0.0424	0.1716	0.0443	0.1432

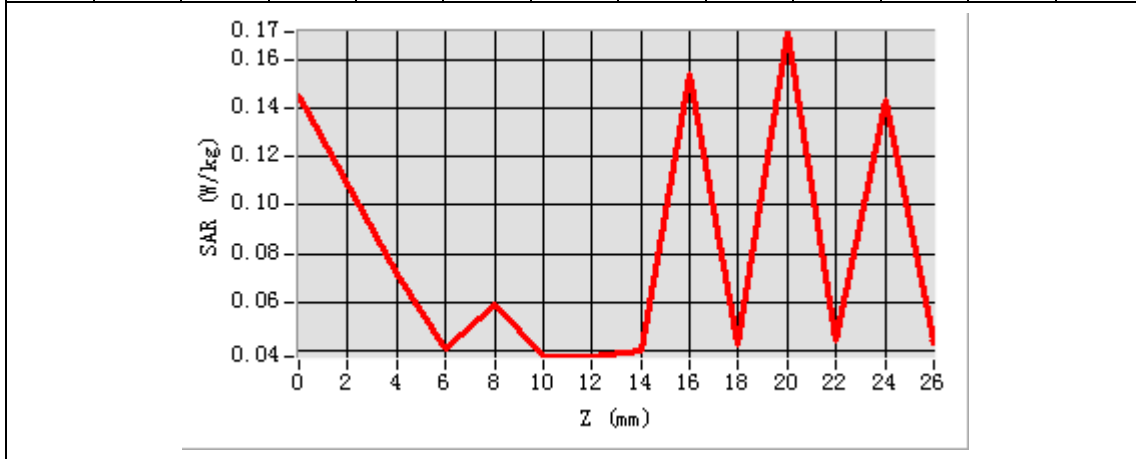

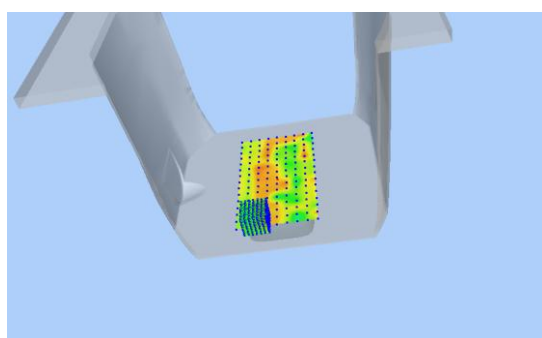
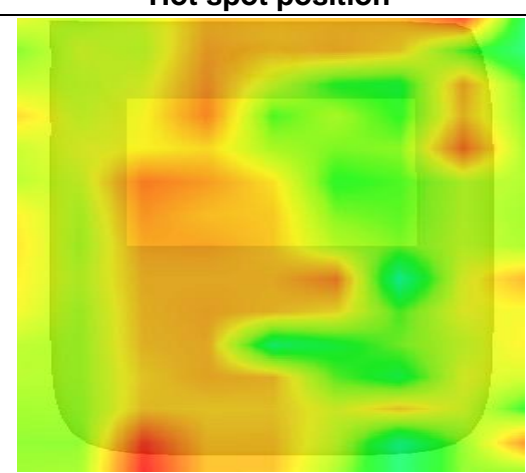
3D screen shot	Hot spot position
	

NOTE: This document is issued by MORLAB, the test report shall not be reproduced except in full without prior written permission of the company. The test results apply only to the particular sample(s) tested and to the specific tests carried out which is available on request for validation and information confirmed at our website.