

(Plot O3.1, HSUPA1900MHz, Channel = 9538 1GHz to 20GHz)

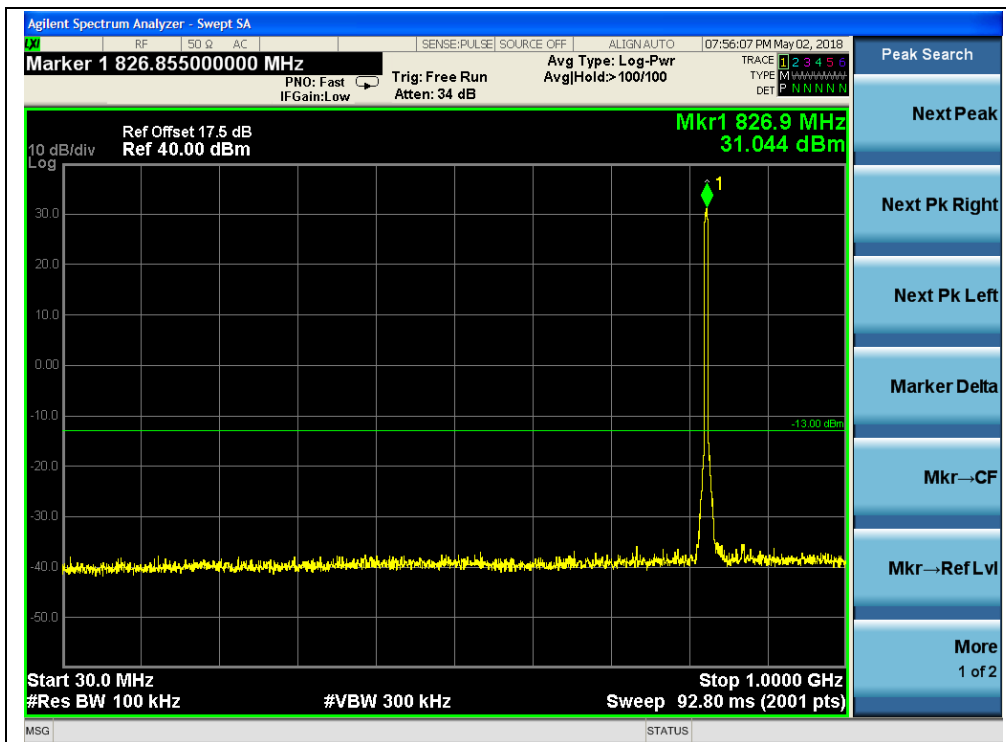

(Plot P1, HSPA+ 850MHz, Channel = 4132, 30MHz to 1GHz)



(Plot P1.1, HSPA+ 850MHz, Channel = 4132, 1GHz to 9GHz)

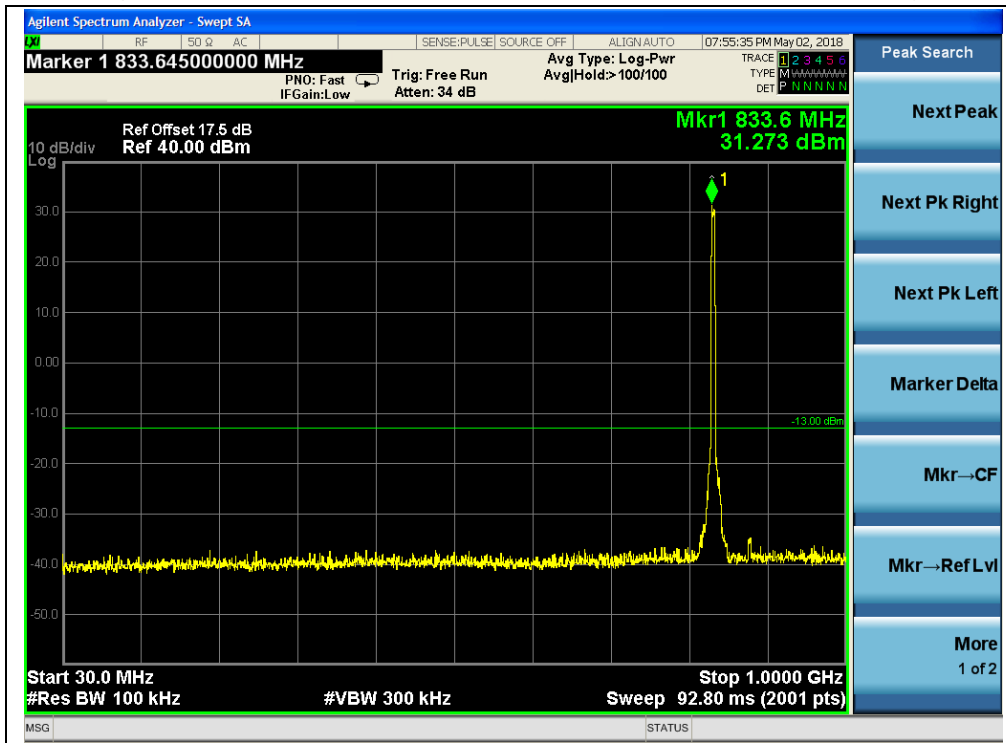

(Plot P2, HSPA+ 850MHz, Channel = 4175, 30MHz to 1GHz)



(Plot P2.1, HSPA+ 850MHz, Channel = 4175, 1GHz to 9GHz)

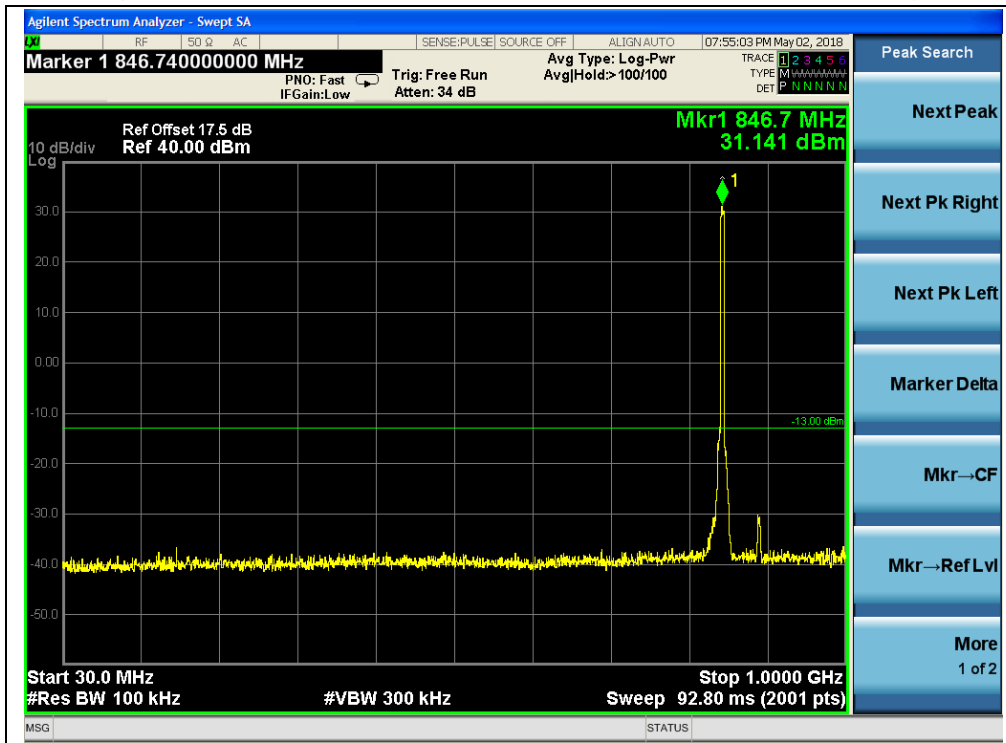

(Plot P3, HSPA+ 850MHz, Channel = 4233, 30MHz to 1GHz)



(Plot P3.1, HSPA+ 850MHz, Channel = 4233, 1GHz to 9GHz)

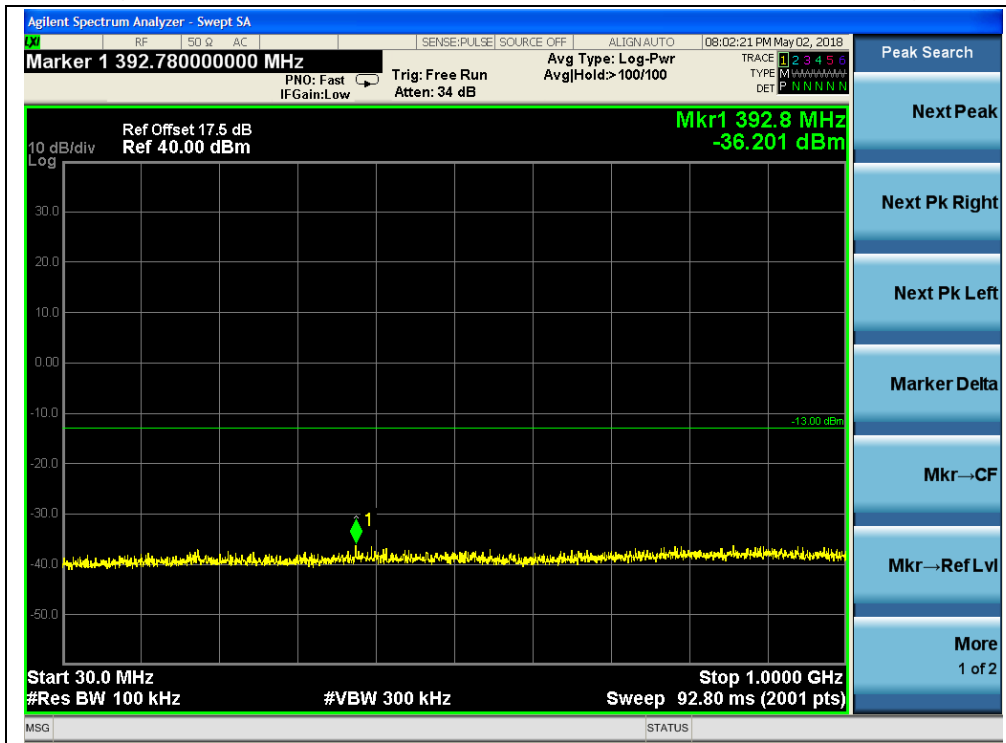

(Plot Q1, HSPA+1700MHz, Channel = 1312, 30MHz to 1GHz)

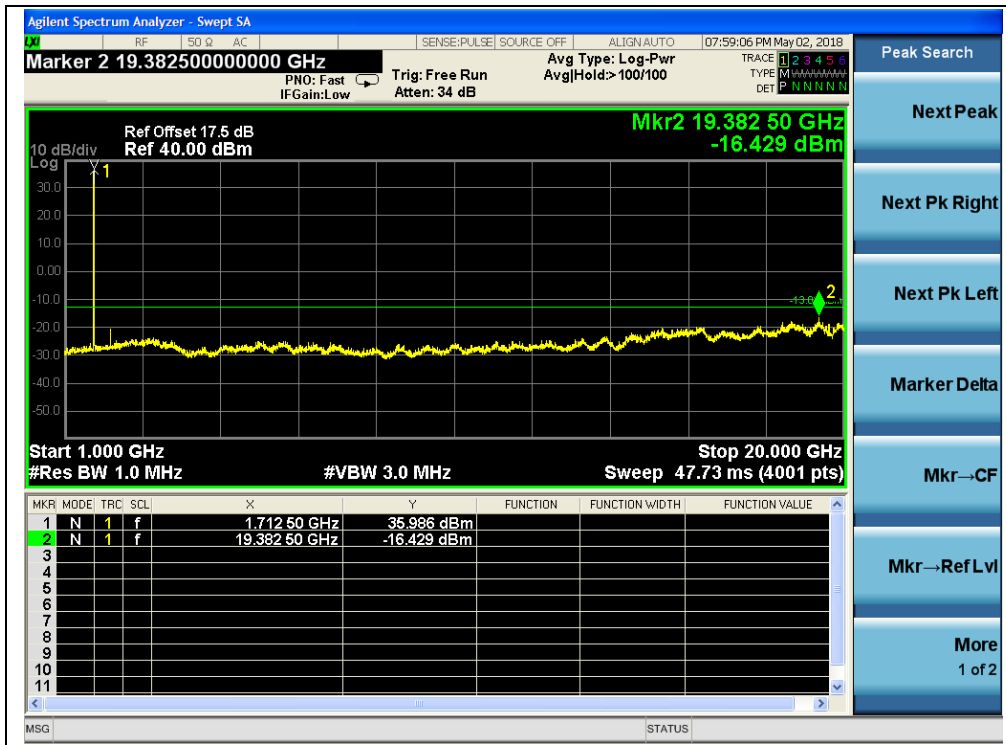

(Plot Q1.1, HSPA+ 1700MHz, Channel = 1312, 1GHz to 20GHz)

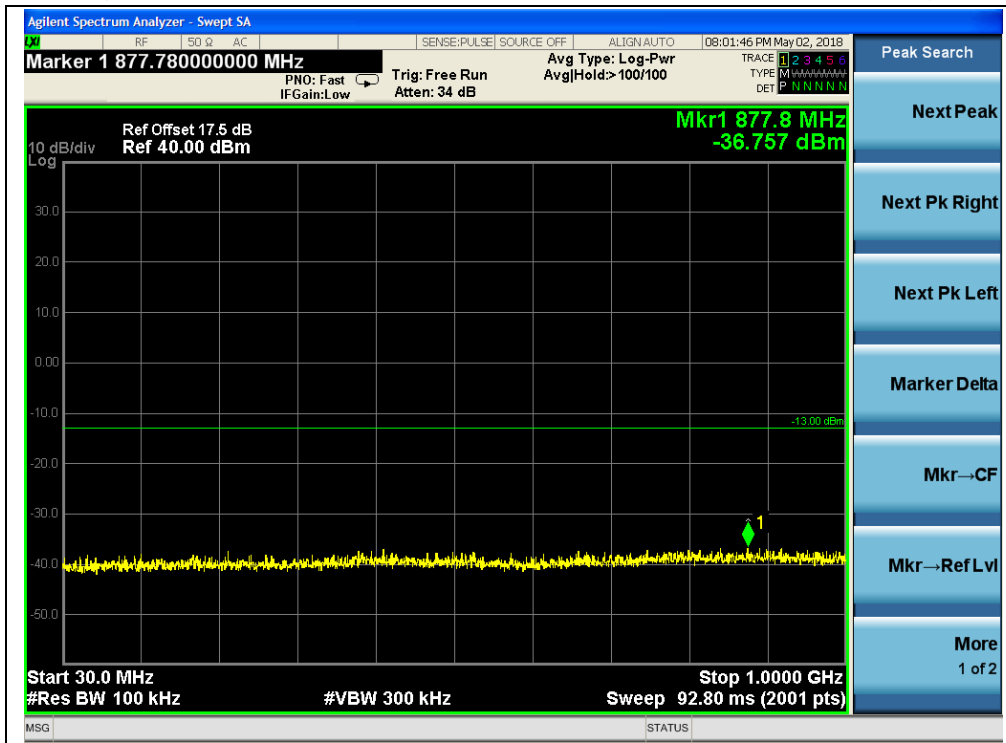

(Plot Q2, HSPA+ 1700MHz, Channel = 1412, 30MHz to 1GHz)

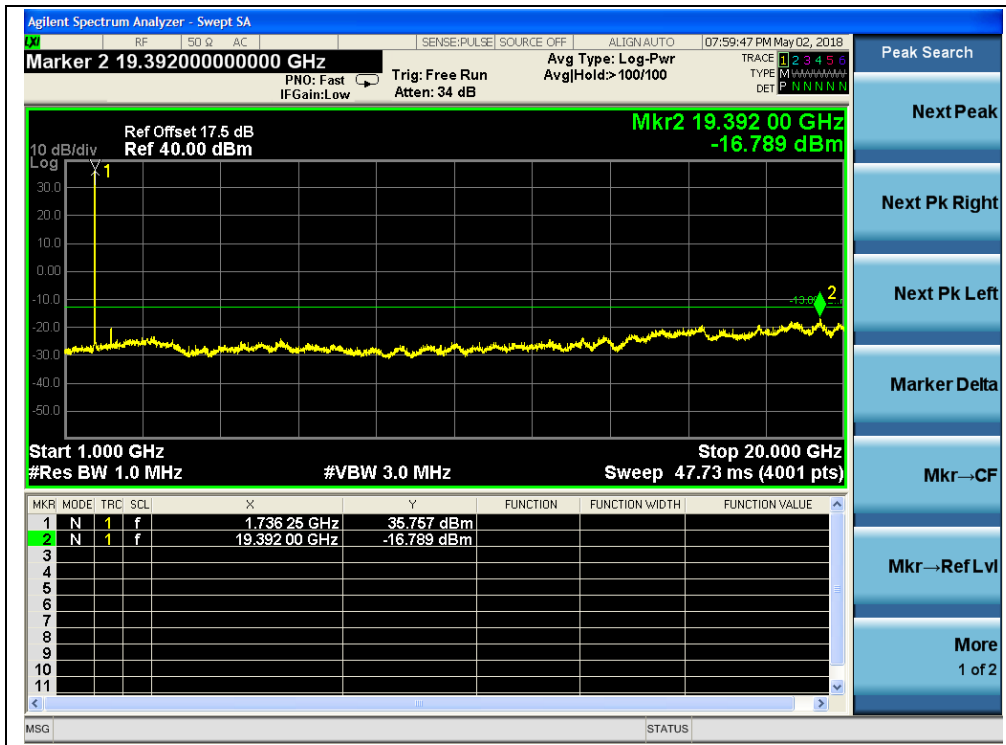

(Plot Q2.1, HSPA+1700MHz, Channel = 1412, 1GHz to 20GHz)

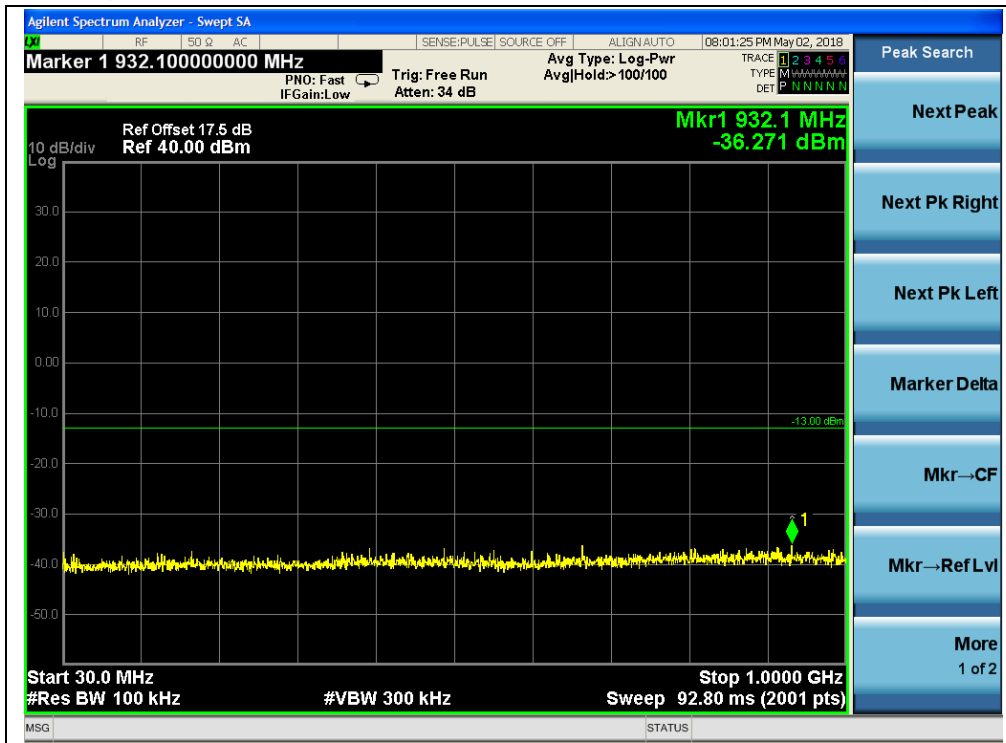

(Plot Q3, HSPA+1700MHz, Channel = 1513, 30MHz to 1GHz)

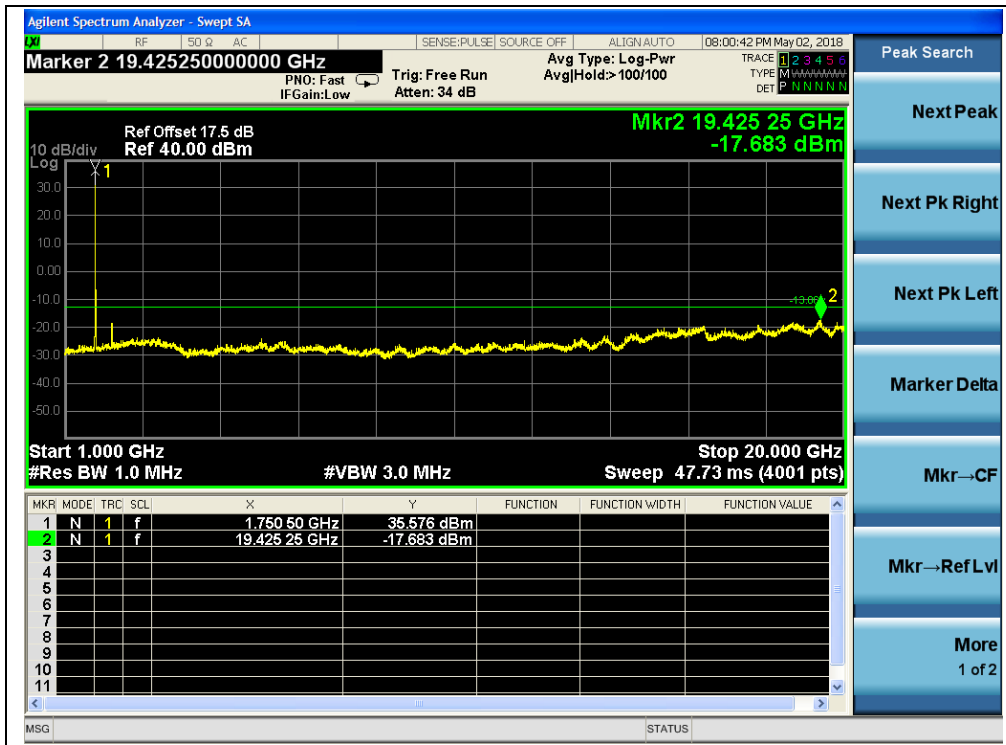

(Plot Q3.1, HSPA+1700MHz, Channel = 1513, 1GHz to 20GHz)

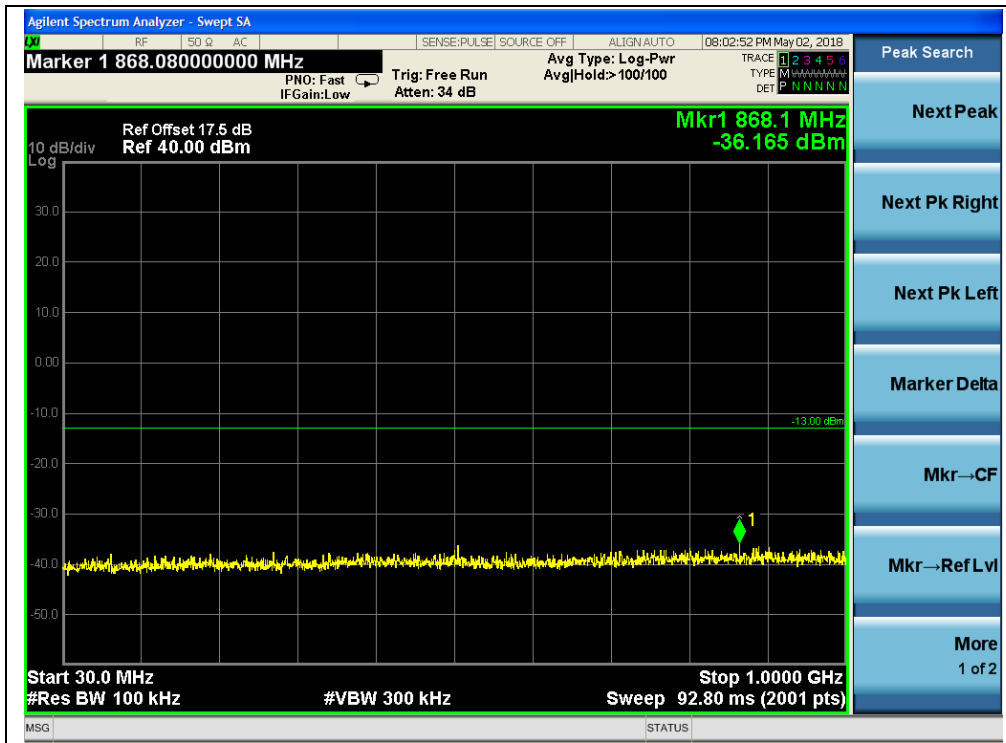

(Plot R1, HSPA+ 1900MHz, Channel = 9262, 30MHz to 1GHz)

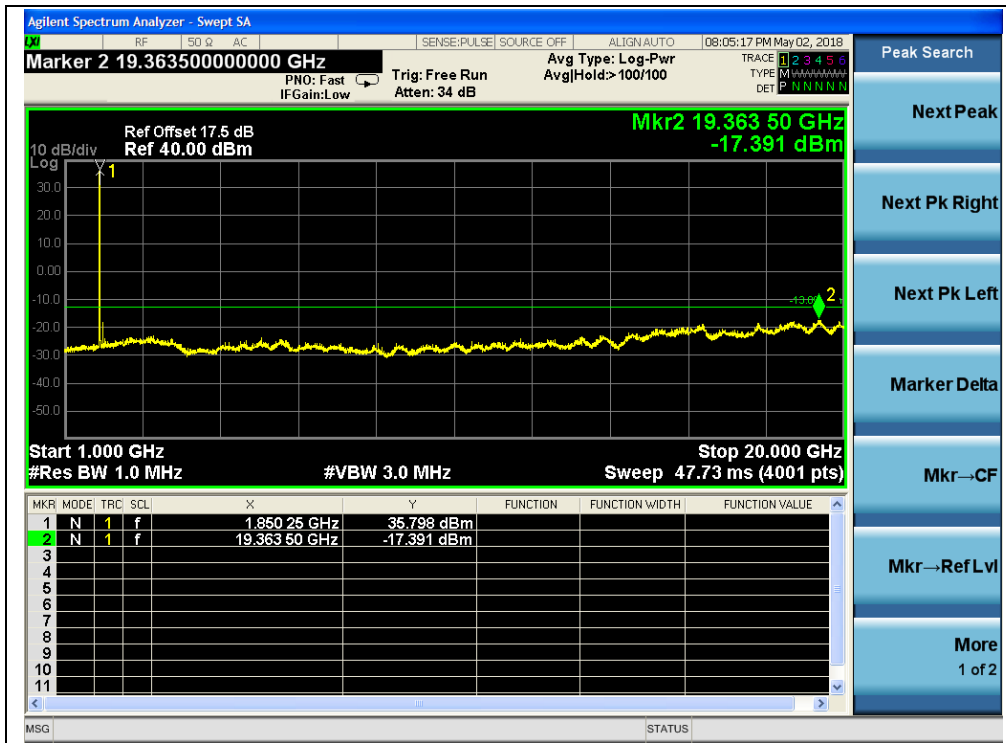

(Plot R1.1, HSPA+ 1900MHz, Channel = 9262, 1GHz to 20GHz)

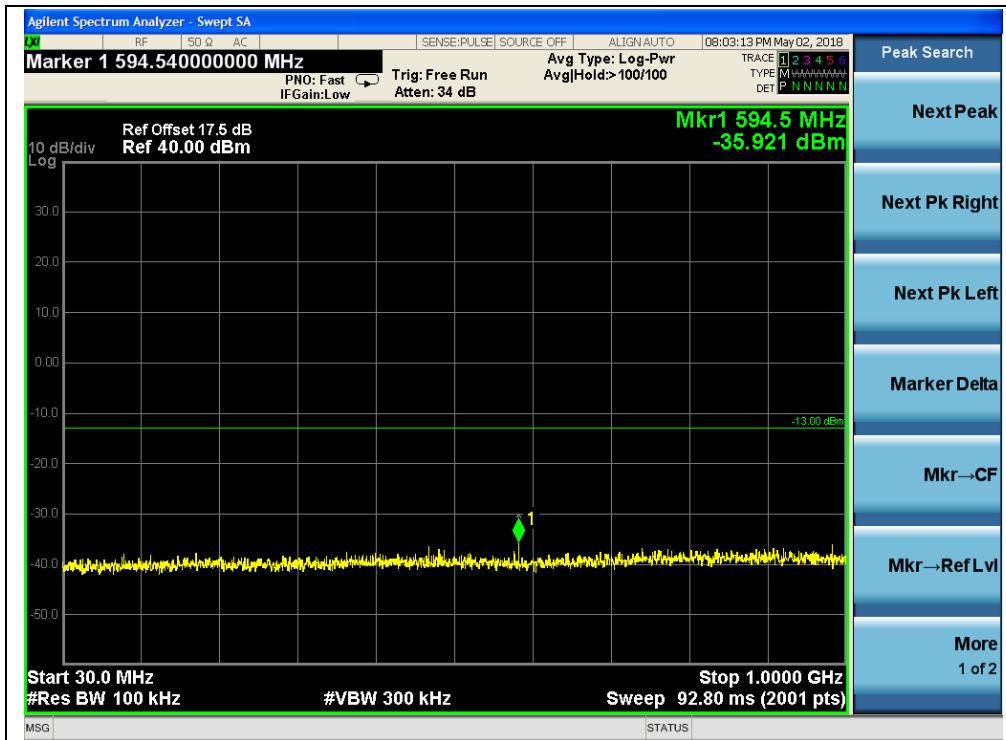

(Plot R2, HSPA+ 1900MHz, Channel = 9400, 30MHz to 1GHz)



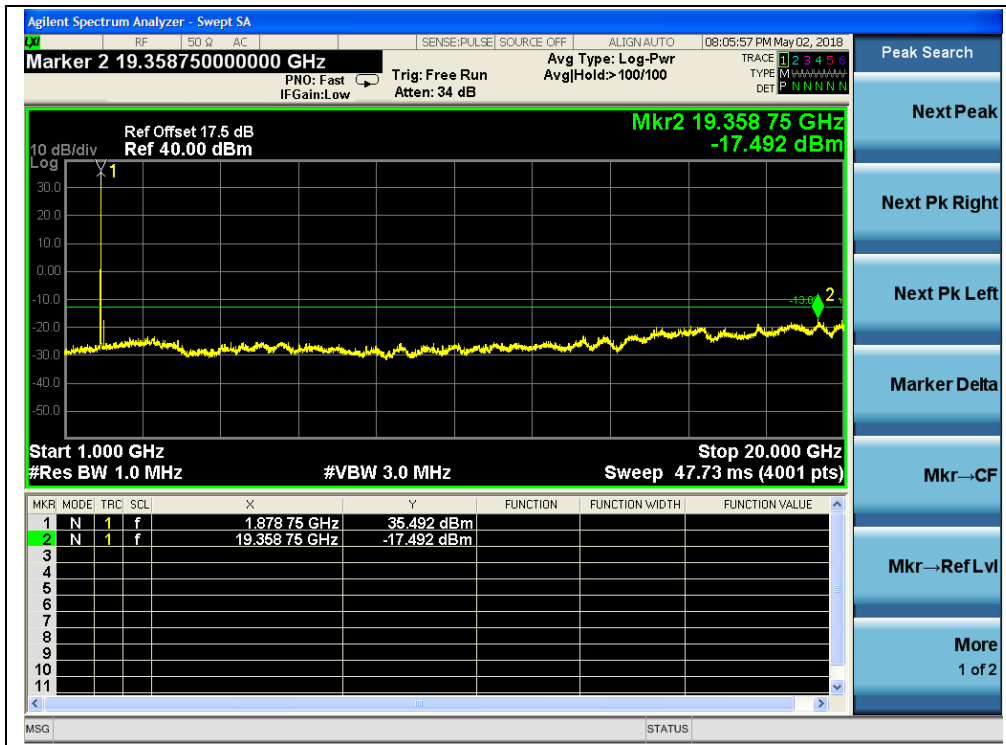

(Plot R2.1, HSPA+1900MHz, Channel = 9400, 1GHz to 20GHz)

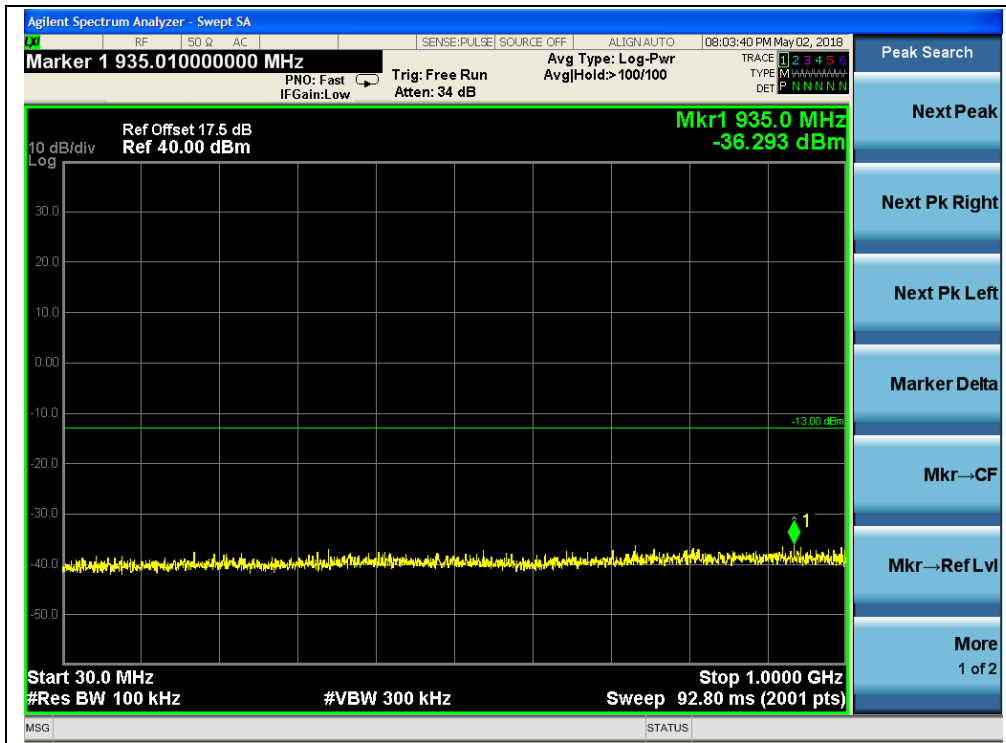

(Plot R3, HSPA+1900MHz, Channel = 9538, 30MHz to 1GHz)

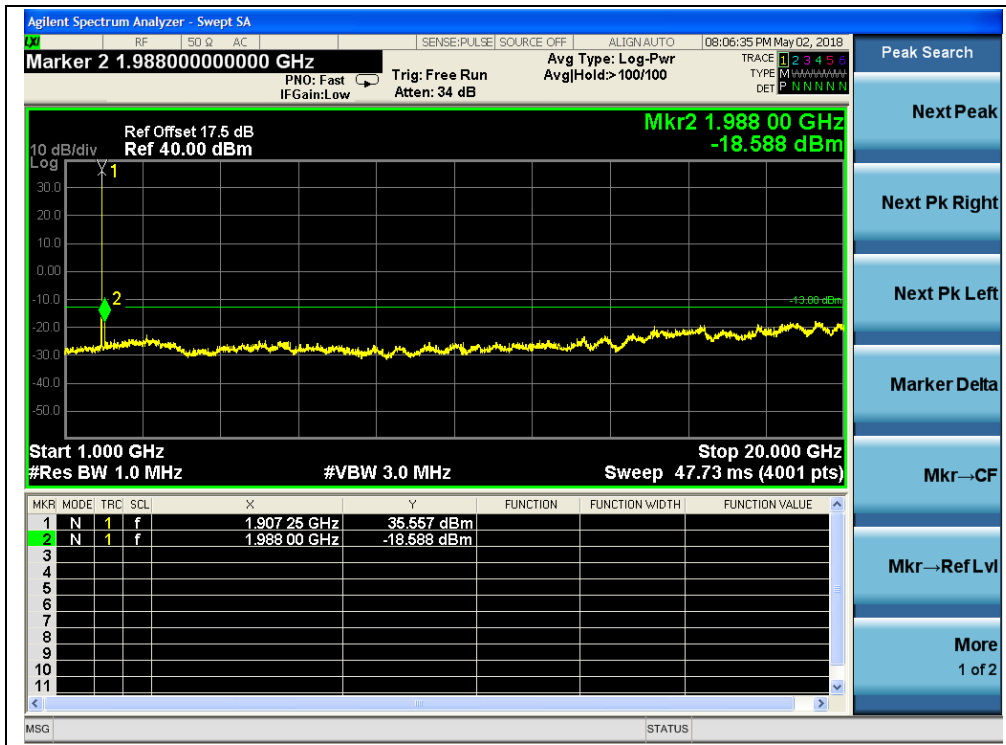

(Plot R3.1, HSPA+1900MHz, Channel = 9538 1GHz to 20GHz)

## 2.6. Band Edge

### 2.6.1. Requirement

According to FCC section 22.917(b) and FCC section 24.238(b) in the 1MHz bands immediately outside and adjacent to the frequency block a resolution bandwidth of at least one percent of the emission bandwidth (26dB emission bandwidth) of the fundamental emission of the transmitter may be employed.

### 2.6.2. Test Description

Test Setup:

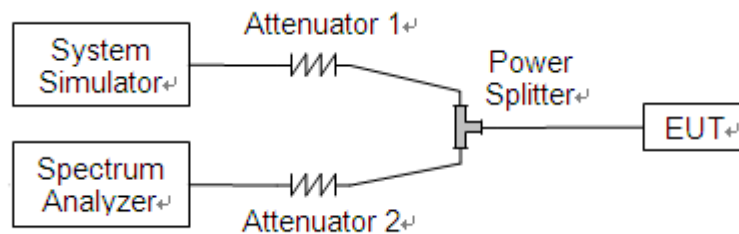

The EUT is coupled to the Spectrum Analyzer (SA) and the System Simulator (SS) with Attenuators through the Power Splitter; the RF load attached to the EUT antenna terminal is 50Ohm; the path loss as the factor is calibrated to correct the reading. The EUT is commanded by the SS to operate at the maximum output power i.e. Power Control Level (PCL) = 5 and Power Class = 4. A call is established between the EUT and the SS.



2.6.3. Test Result

The lowest and highest channels are tested to verify the band edge emissions.

A. Test Verdict:

Band	Channel	Frequency (MHz)	Measured Max. Band Edge Emission (dBm)	Refer to Plot	Limit (dBm)	Verdict
GSM 850MHz	128	824.2	-14.61	Plat A1	-13	PASS
	251	848.8	-14.36	Plot A2		PASS
GSM 1900MHz	512	1850.2	-17.52	Plat B1	-13	PASS
	810	1909.8	-18.43	Plot B2		PASS
EGPRS 850MHz	128	824.2	-19.88	Plat C1	-13	PASS
	251	848.8	-21.09	Plot C2		PASS
EGPRS 1900MHz	512	1850.2	-22.30	Plat D1	-13	PASS
	810	1909.8	-22.23	Plot D2		PASS

B. Test Plots:

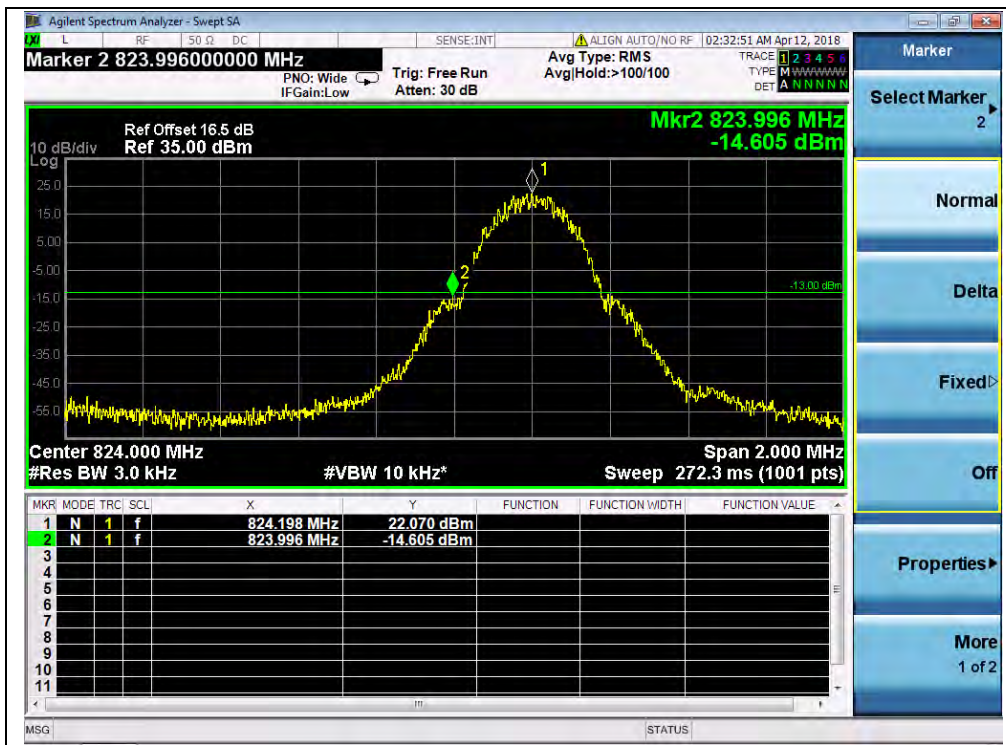

(Plot A1, GSM 850, Channel = 128)

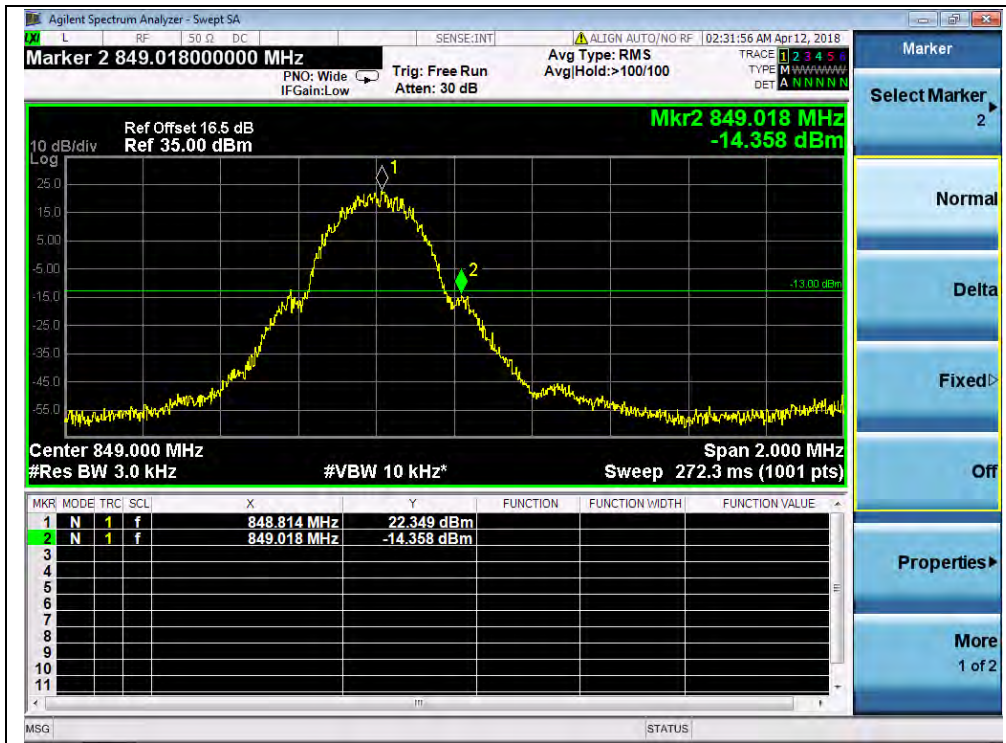

(Plot A2, GSM 850, Channel = 251)

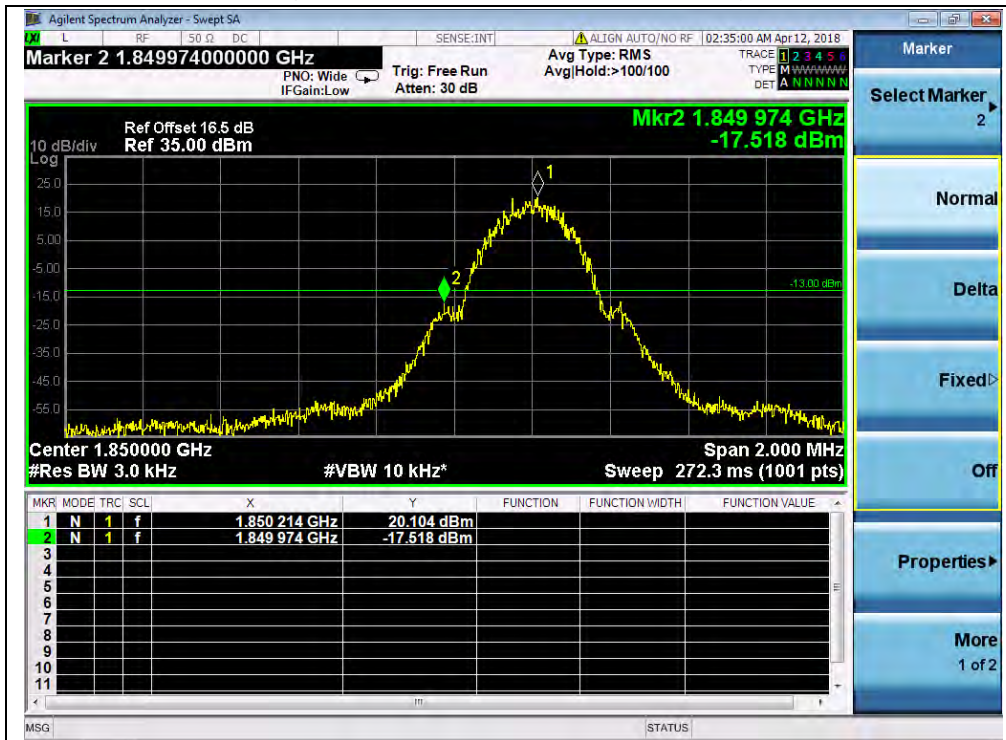

(Plot B1, GSM 1900, Channel = 512)

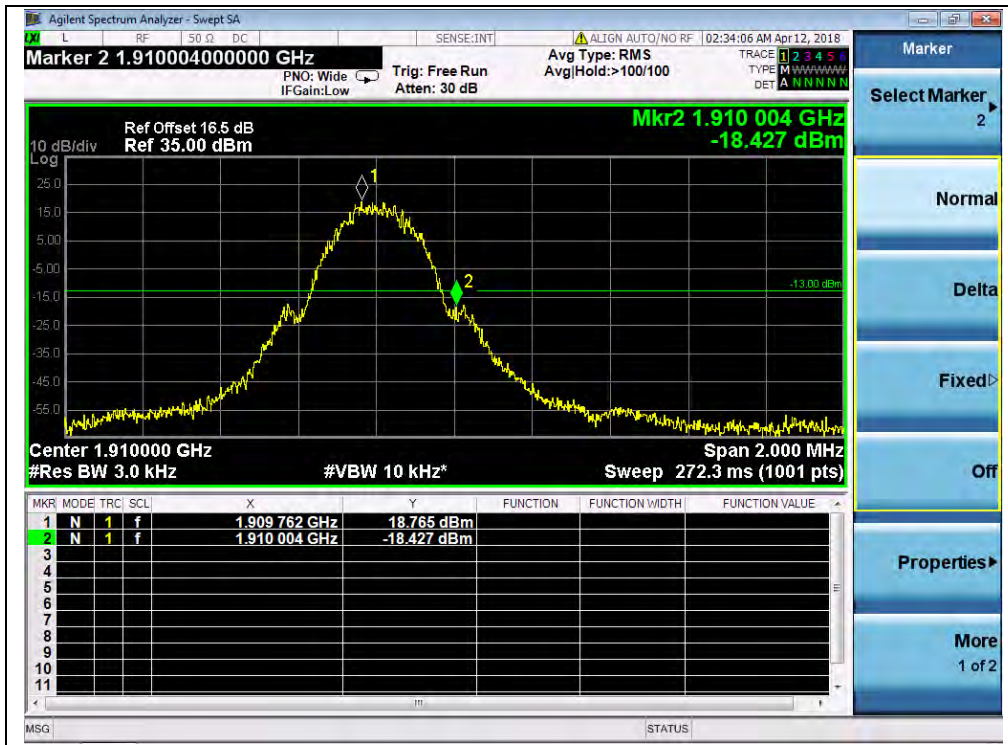

(Plot B2, GSM 1900, Channel = 810)

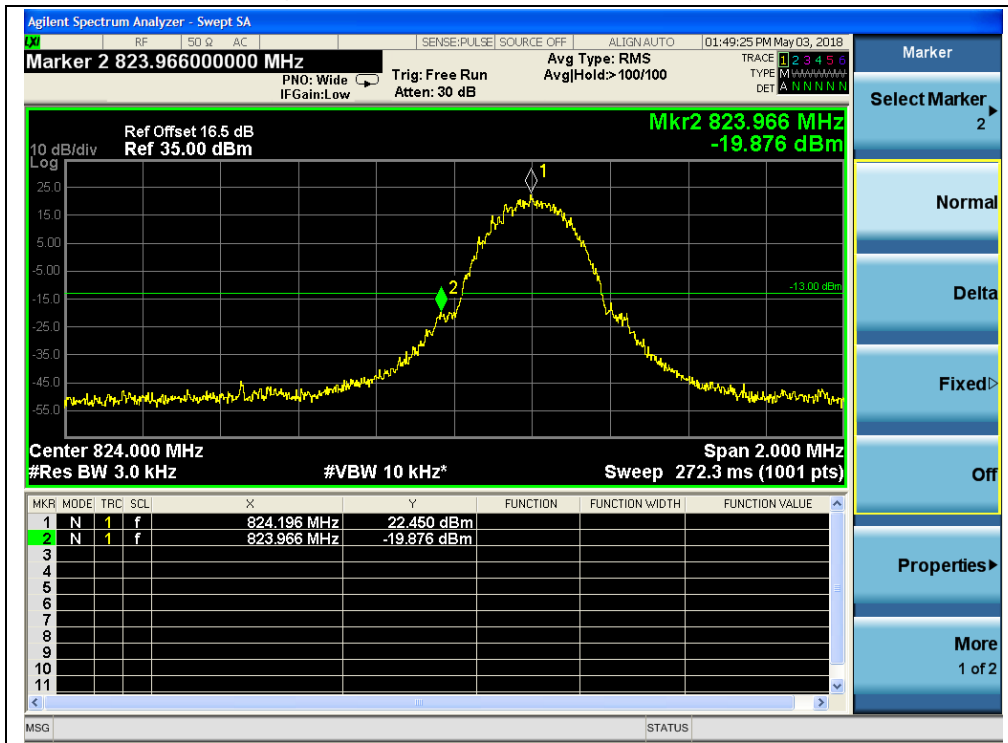

(Plot C1, EGPRS 850, Channel = 128)

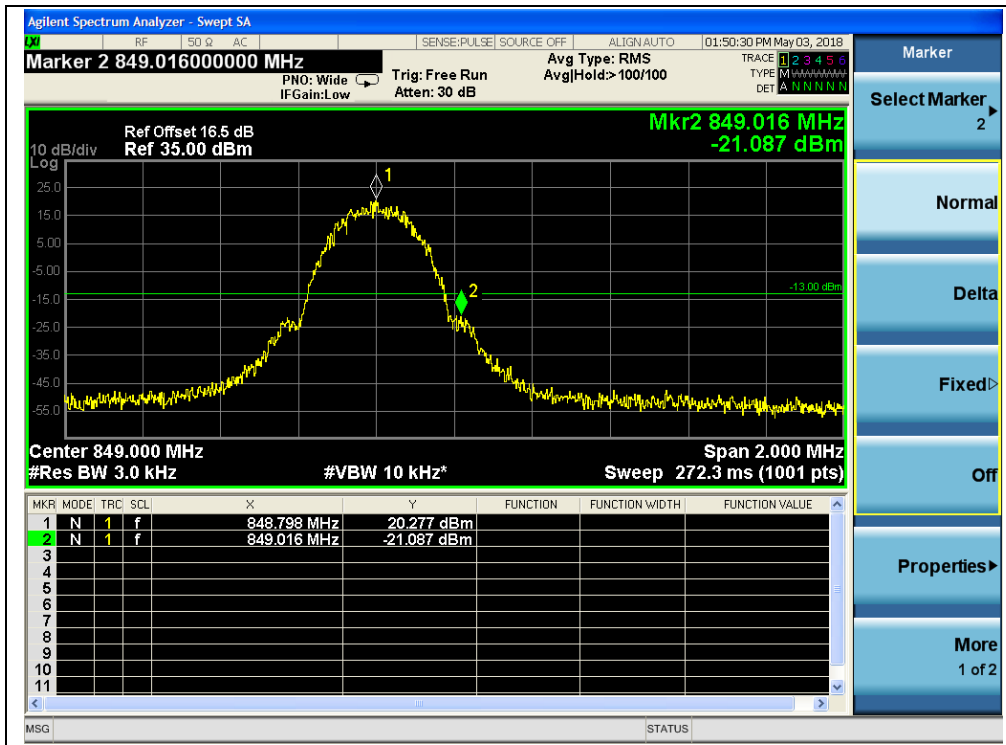

(Plot C2, EGPRS 850, Channel = 251)

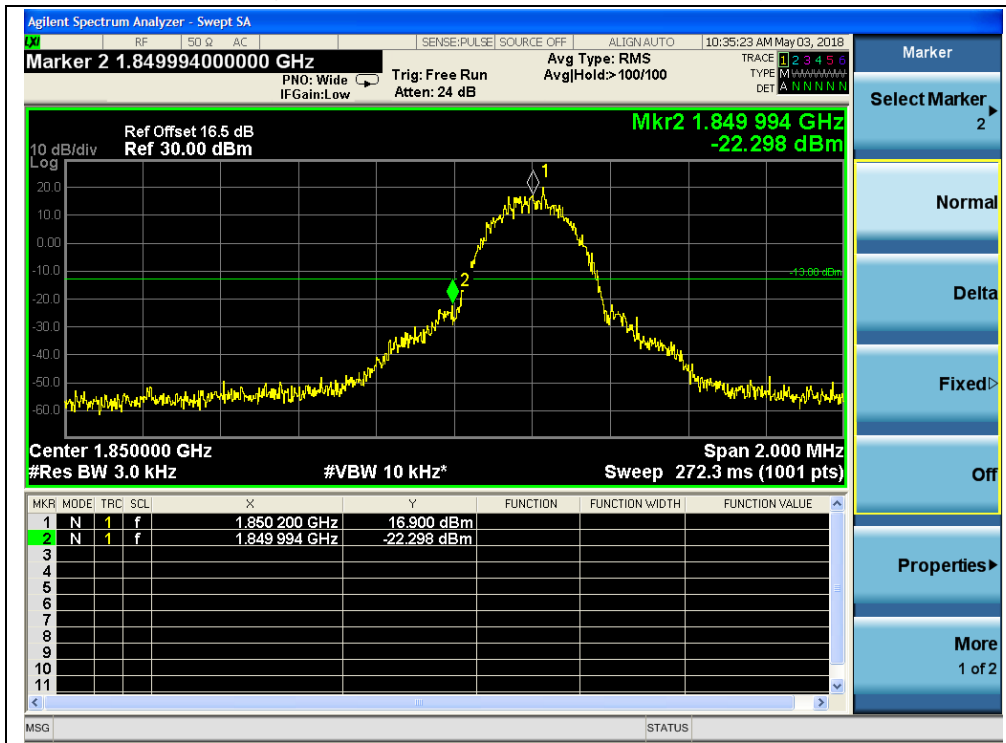

(Plot D1, EGPRS 1900, Channel = 512)

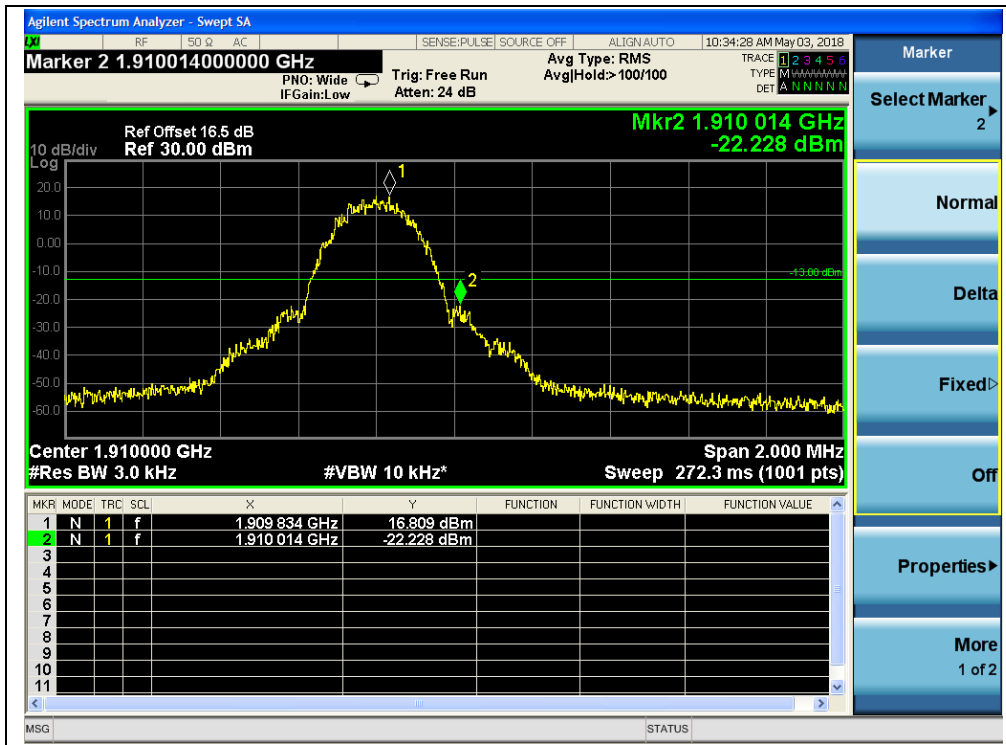

(Plot D2, EGPRS 1900, Channel = 810)





**WCDMA Test Verdict**

Band	Channel	Frequency (MHz)	Measured Max. Band Edge Emission (dBm)	Refer to Plot	Limit (dBm)	Verdict
WCDMA 850MHz	4132	826.4	-31.01	Plat E1	-13	PASS
	4233	846.6	-29.91	Plot E2		PASS
WCDMA 1700MHz	1312	1712.4	-30.25	Plat F1	-13	PASS
	1513	1752.6	-26.92	Plot F2		PASS
WCDMA 1900MHz	9262	1852.4	-27.51	Plat G1	-13	PASS
	9538	1907.6	-28.88	Plot G2		PASS
HSDPA 850MHz	4132	826.4	-31.25	Plat H1	-13	PASS
	4233	846.6	-32.25	Plot H2		PASS
HSDPA 1700MHz	1312	1712.4	-32.93	Plat I1	-13	PASS
	1513	1752.6	-30.49	Plot I2		PASS
HSDPA 1900MHz	9262	1852.4	-27.32	Plat J1	-13	PASS
	9538	1907.6	-32.34	Plot J2		PASS
HSUPA 850MHz	4132	826.4	-31.51	Plat K1	-13	PASS
	4233	846.6	-32.65	Plot K2		PASS
HSUPA 1700MHz	1312	1712.4	-32.92	Plat L1	-13	PASS
	1513	1752.6	-30.92	Plot L2		PASS
HSUPA 1900MHz	9262	1852.4	-27.38	Plat M1	-13	PASS
	9538	1907.6	-32.48	Plot M2		PASS
HSPA+ 850MHz	4132	826.4	-31.14	Plat N1	-13	PASS
	4233	846.6	-31.94	Plot N2		PASS
HSPA+ 1700MHz	1312	1712.4	-32.82	Plat O1	-13	PASS
	1513	1752.6	-31.01	Plot O2		PASS
HSPA+ 1900MHz	9262	1852.4	-27.70	Plat P1	-13	PASS
	9538	1907.6	-32.68	Plot P2		PASS



Test Plot

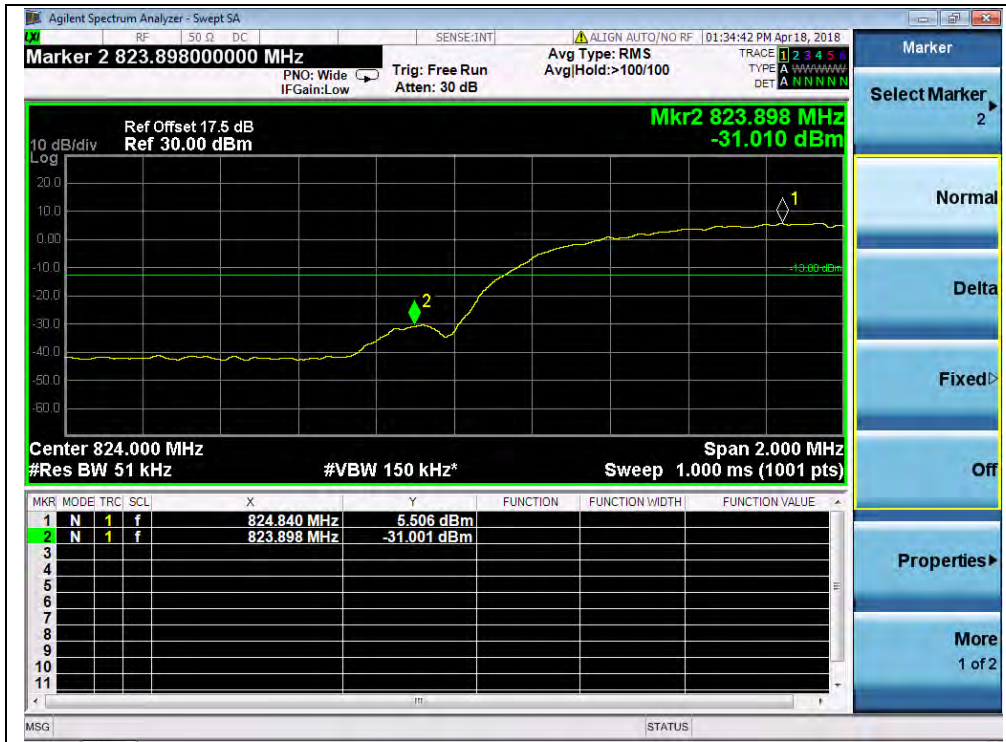

(Plot E1, WCDMA 850, Channel = 4132)

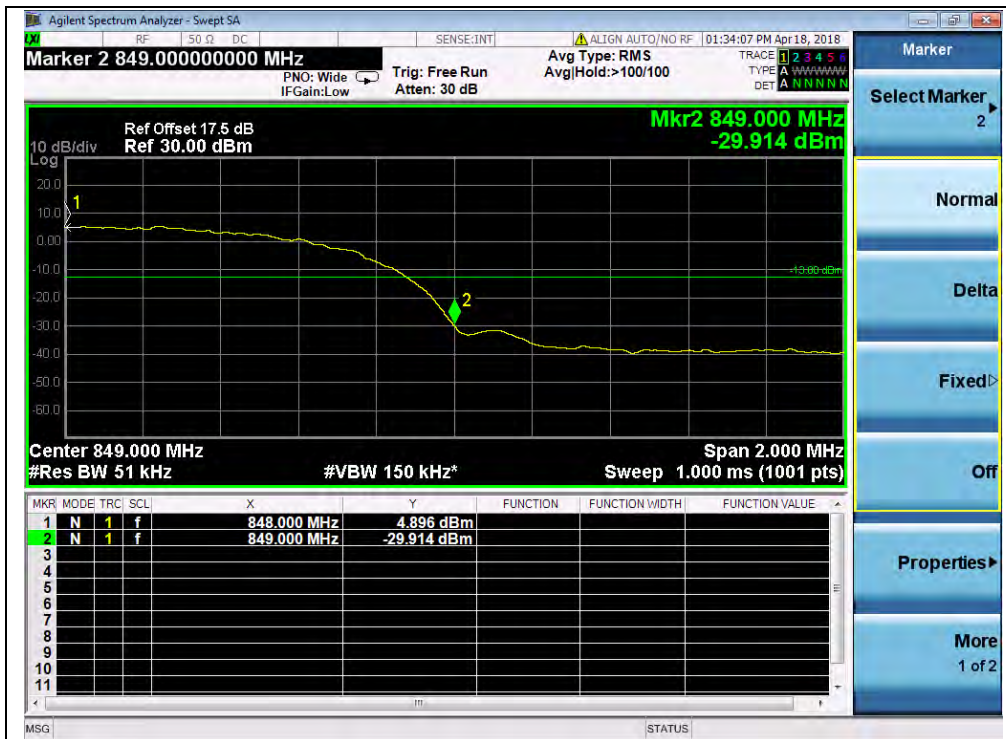

(Plot E2, WCDMA 850, Channel = 4233)

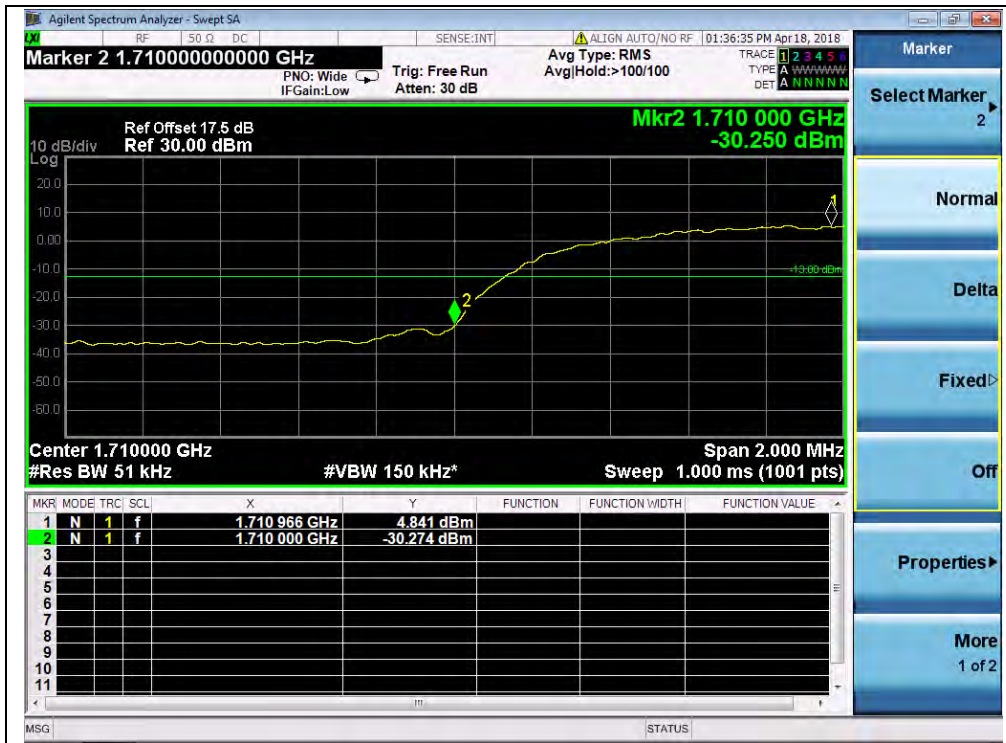

(Plot F1, WCDMA 1700, Channel = 1312)

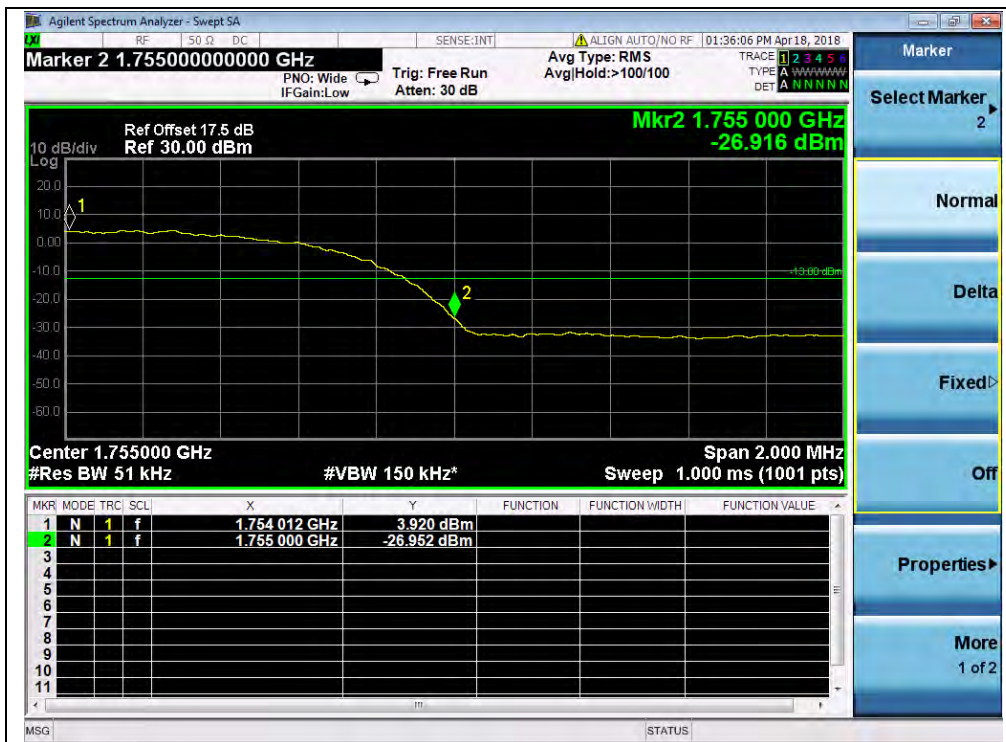

(Plot F2, WCDMA 1700, Channel = 1513)

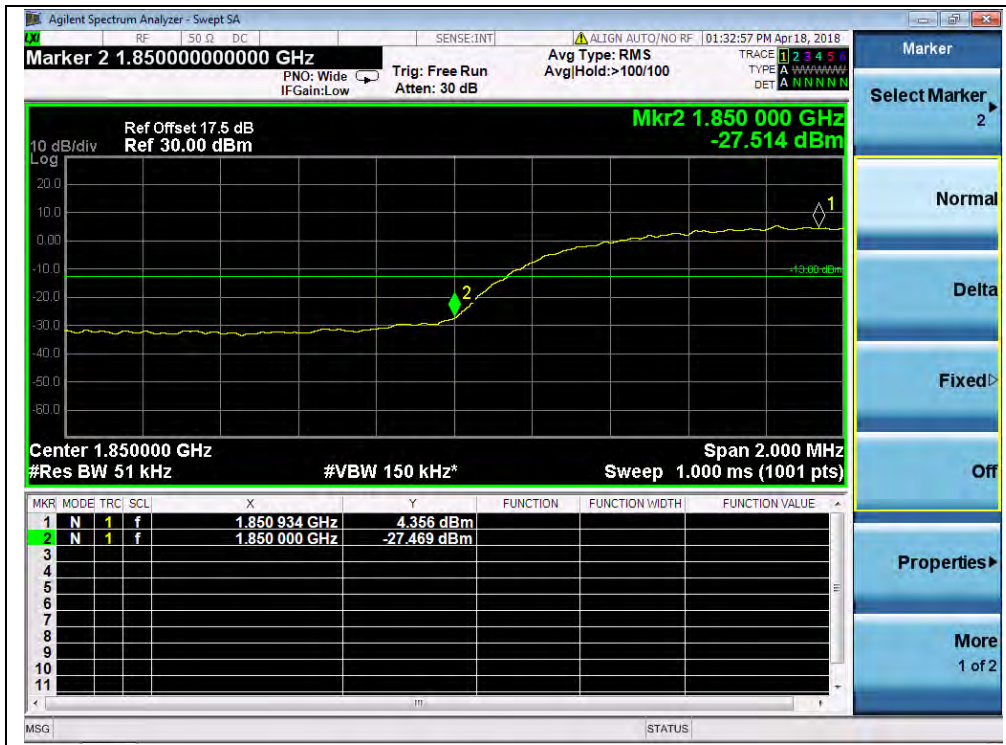

(Plot G1, WCDMA 1900, Channel = 9262)

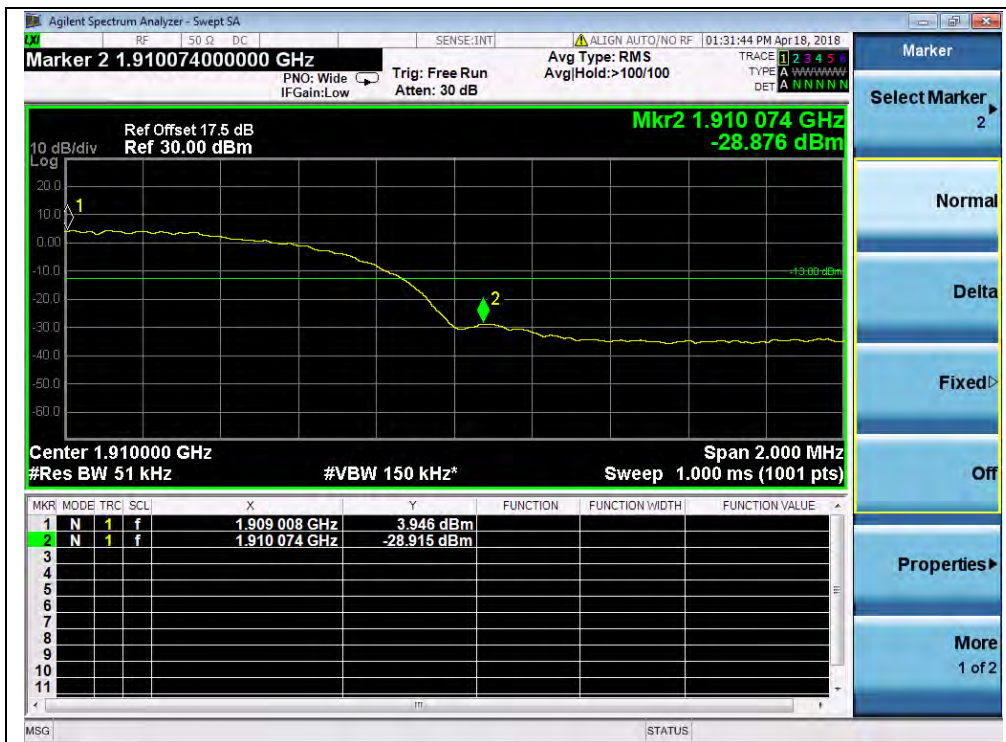

(Plot G2, WCDMA 1900, Channel = 9538)

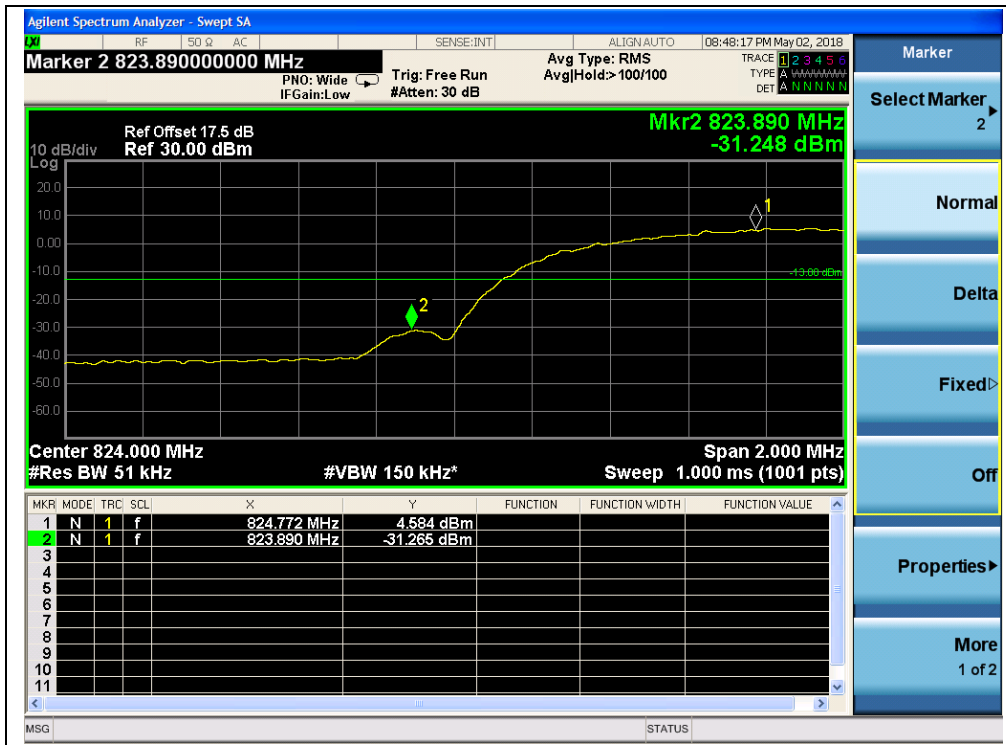

(Plot H1, HSDPA 850, Channel = 4132)



(Plot H2, HSDPA 850, Channel = 4233)

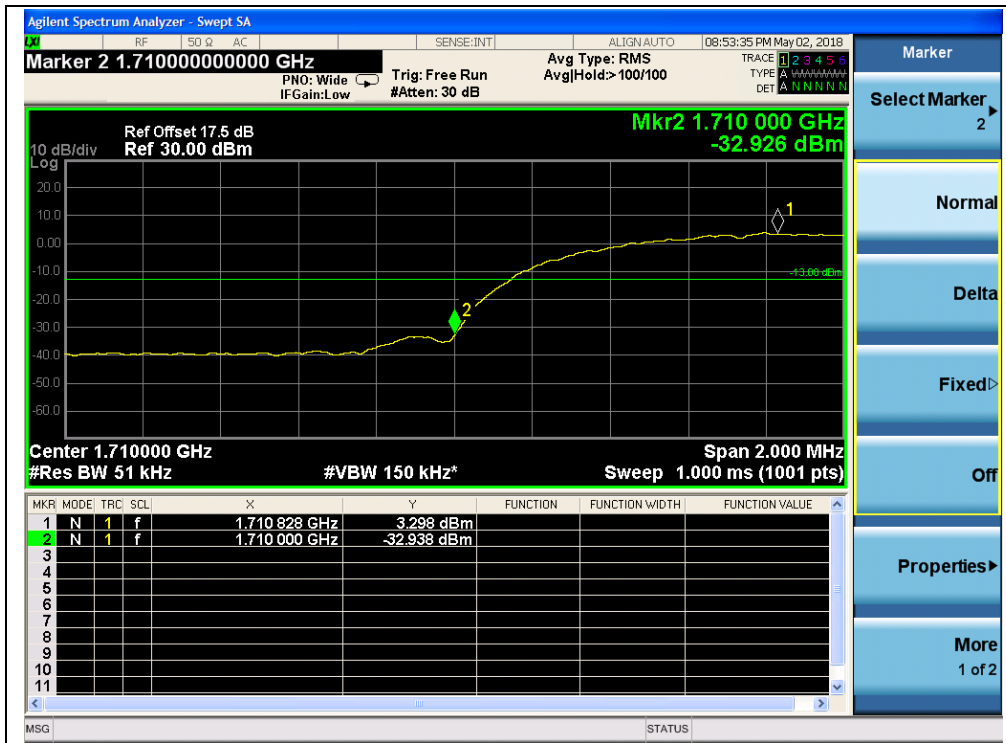

(Plot I1, HSDPA 1700, Channel = 1312)



(Plot I2, HSDPA 1700, Channel = 1513)

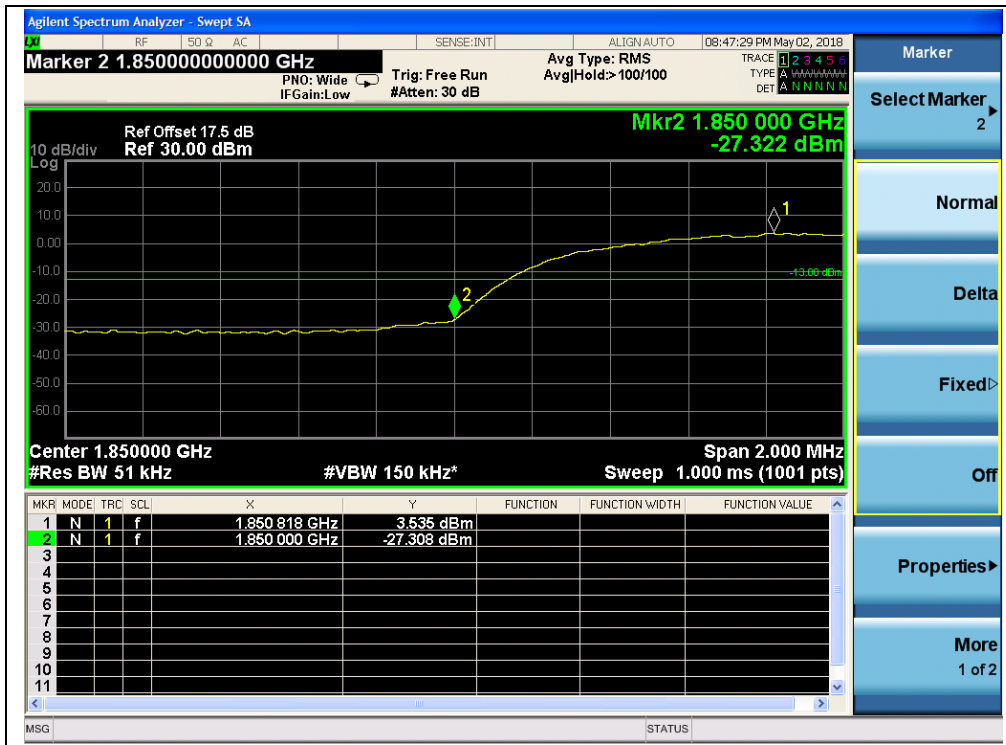

(Plot J1, HSDPA 1900, Channel = 9262)



(Plot J2, HSDPA 1900, Channel = 9538)

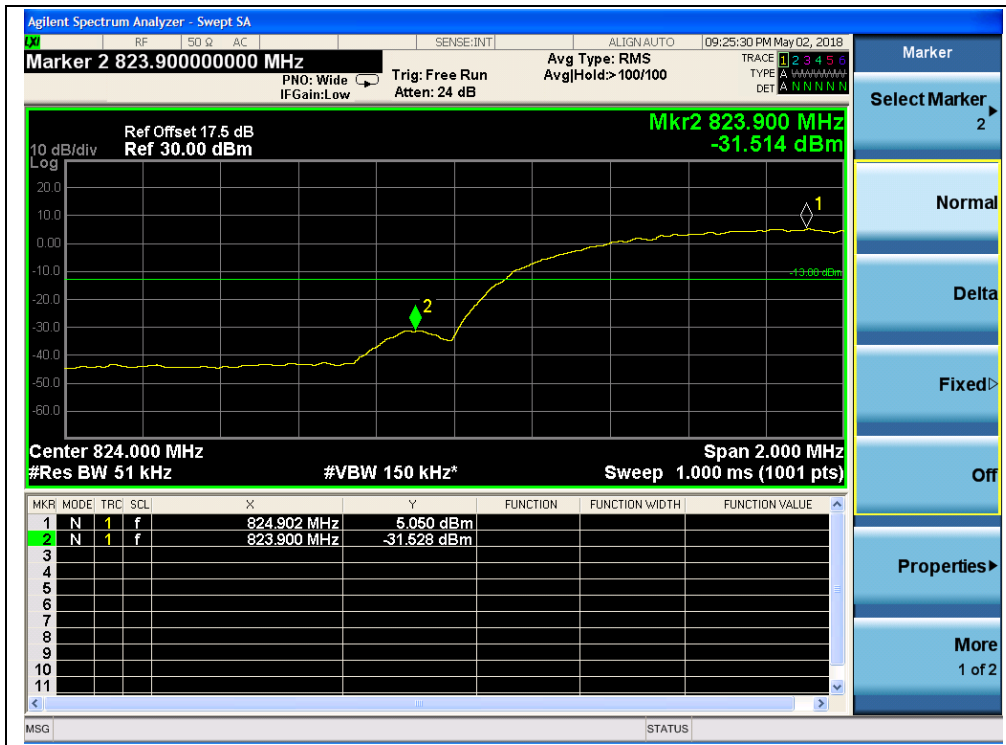

(Plot K1, HSUPA 850, Channel = 4132)

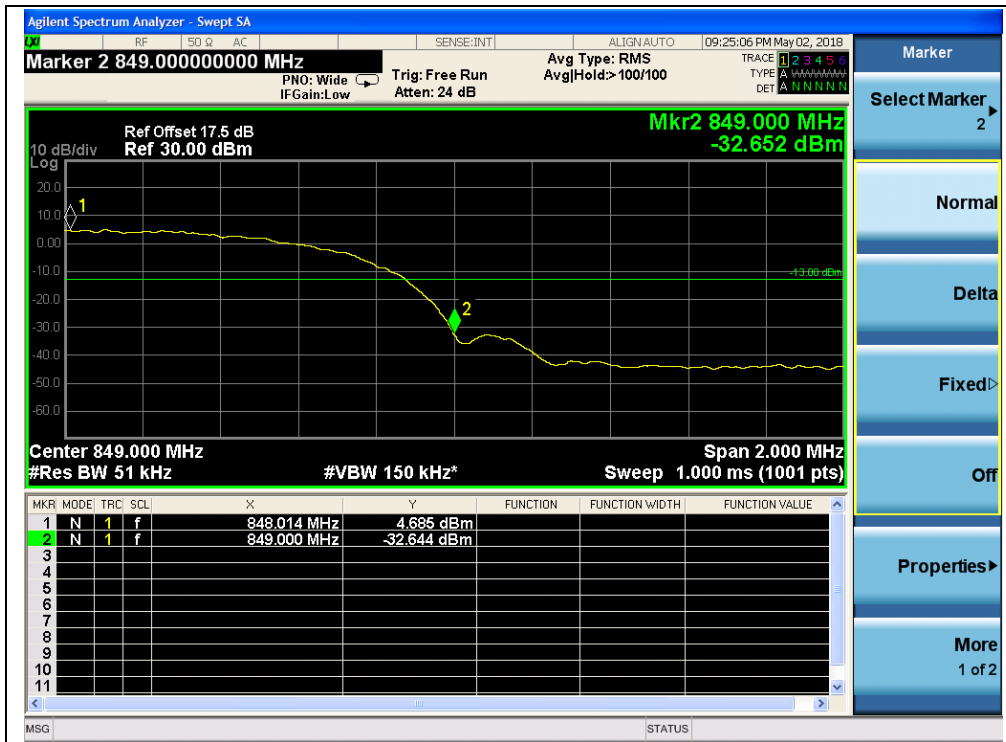

(Plot K2, HSUPA 850, Channel = 4233)



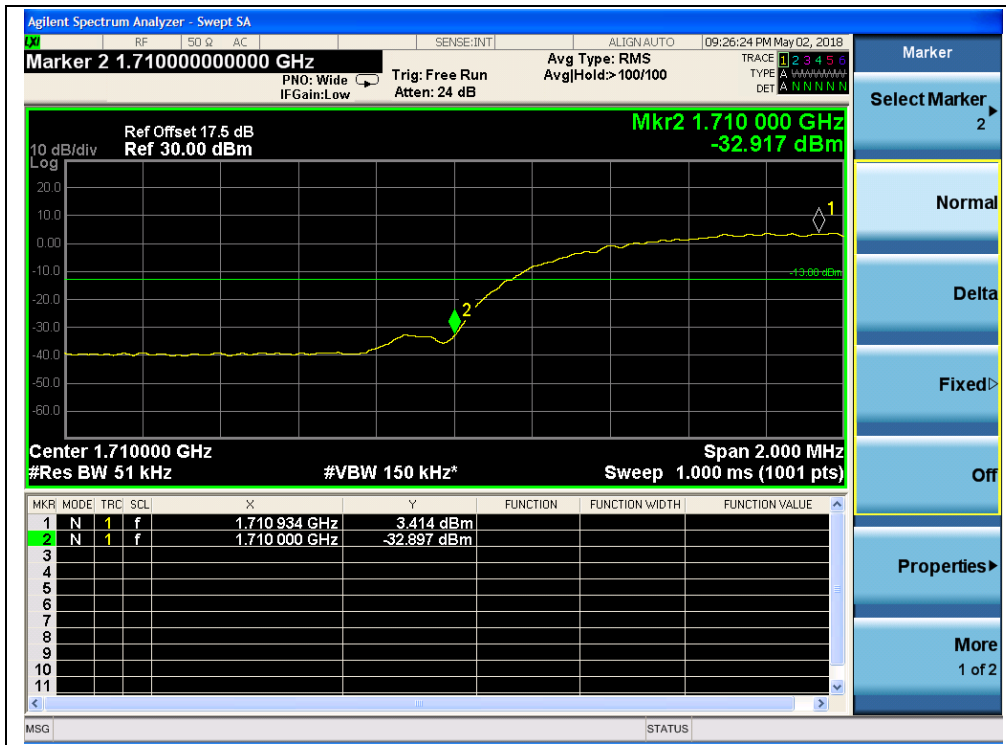

(Plot L1, HSUPA 1700, Channel = 1312)

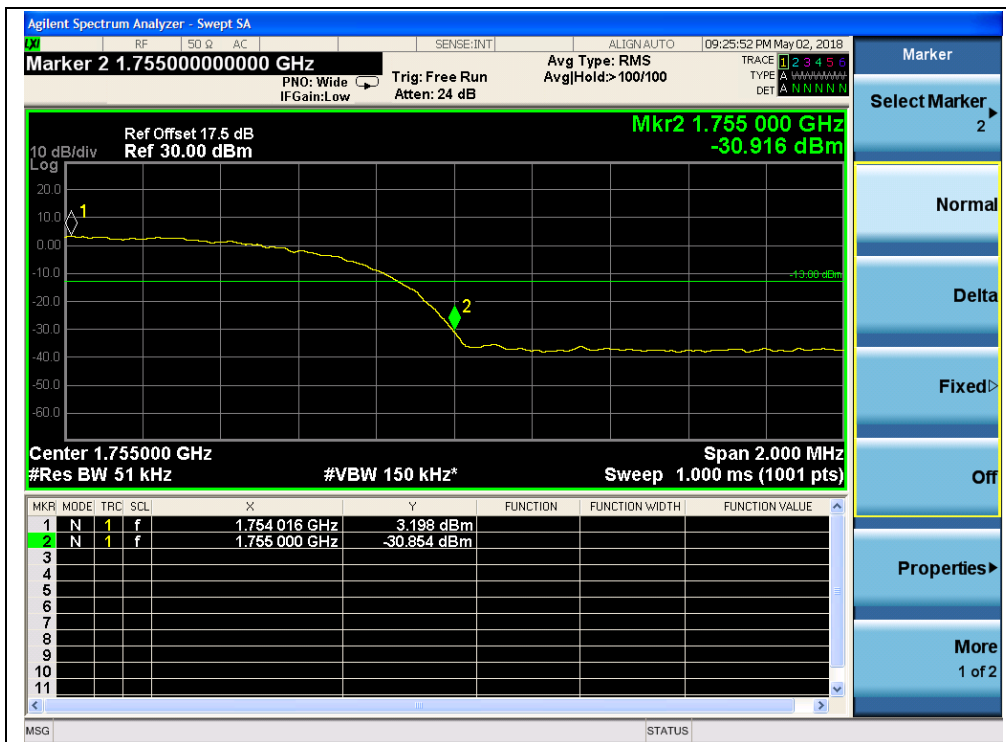

(Plot L2, HSUPA 1700, Channel = 1513)

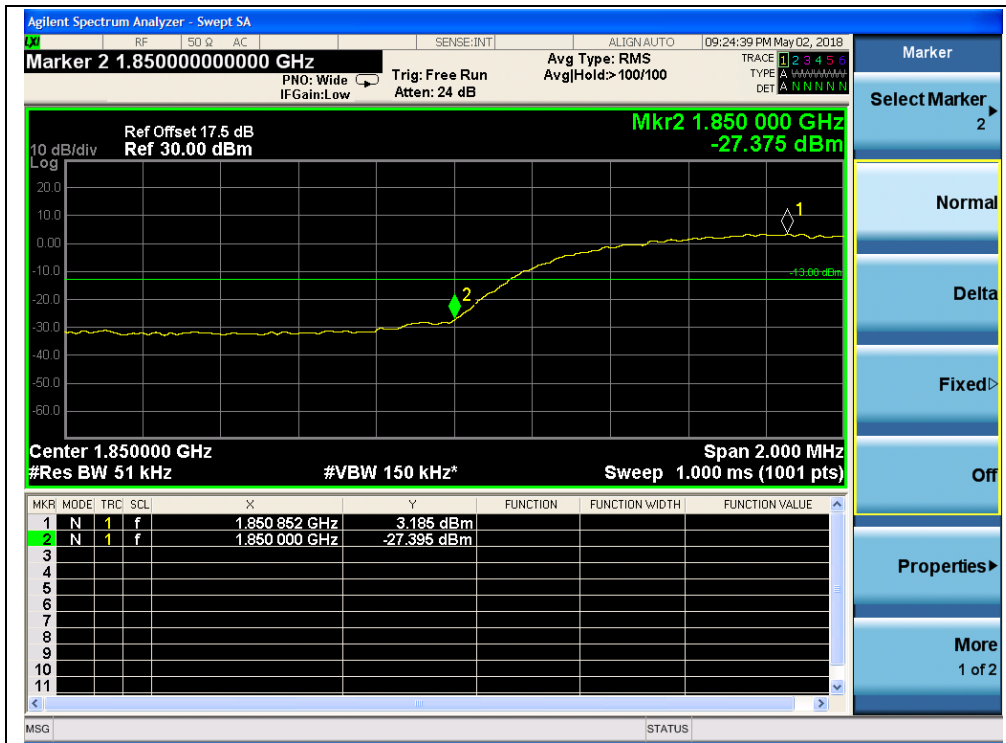

(Plot M1, HSUPA 1900, Channel = 9262)

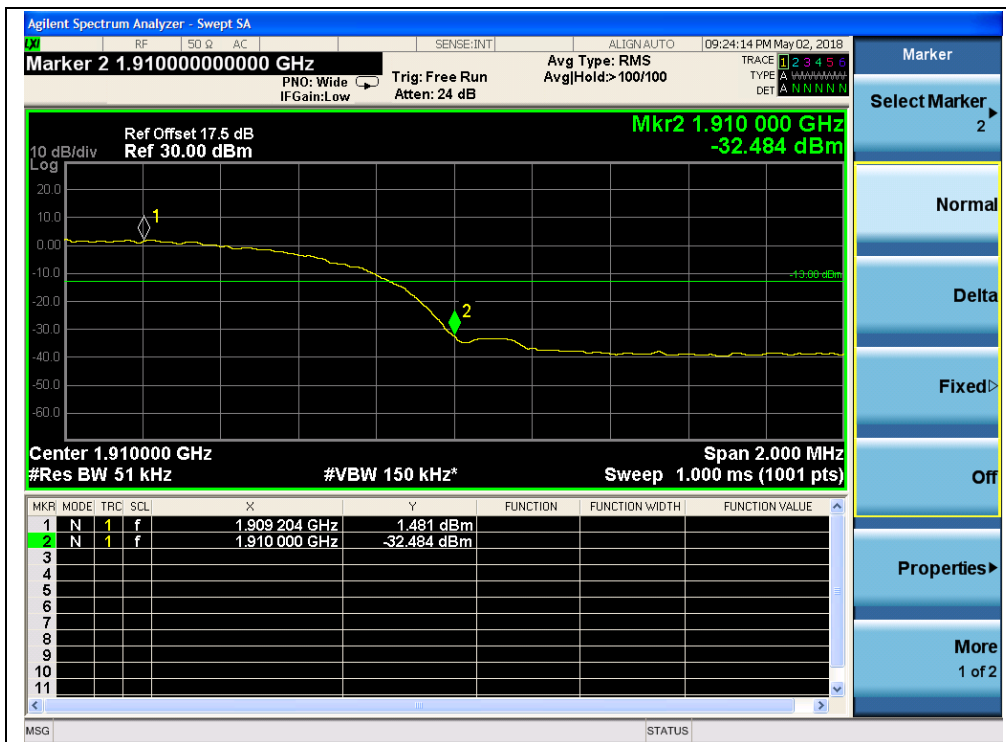

(Plot M2, HSUPA 1900, Channel = 9538)

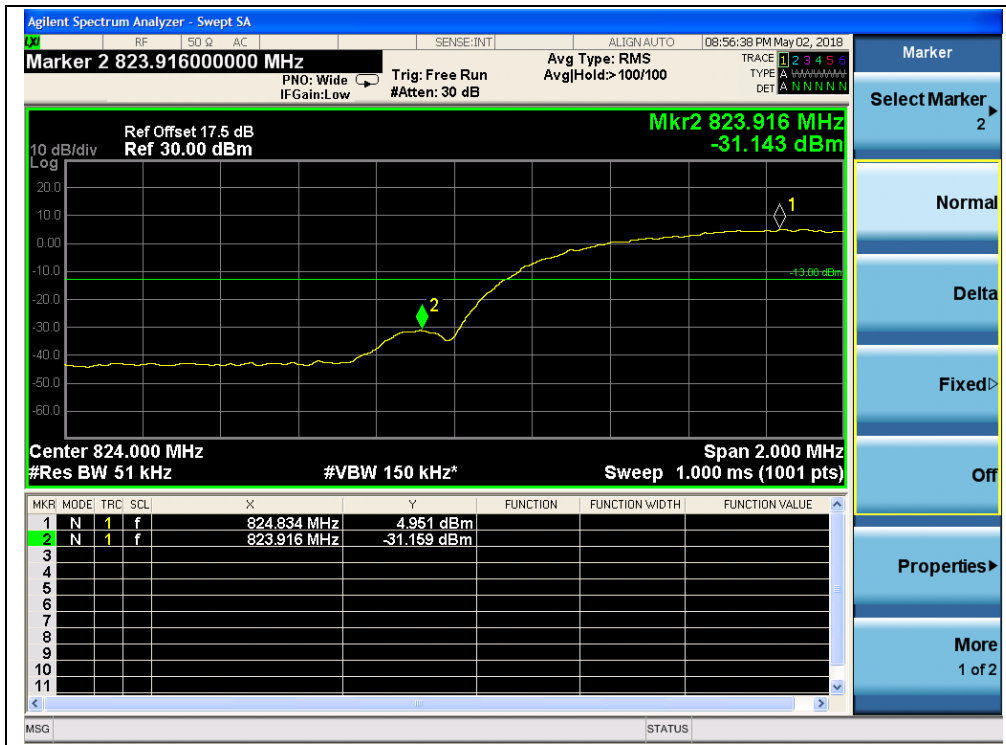

(Plot N1, HSPA+ 850, Channel = 4132)



(Plot N2, HSPA+ 850, Channel = 4233)

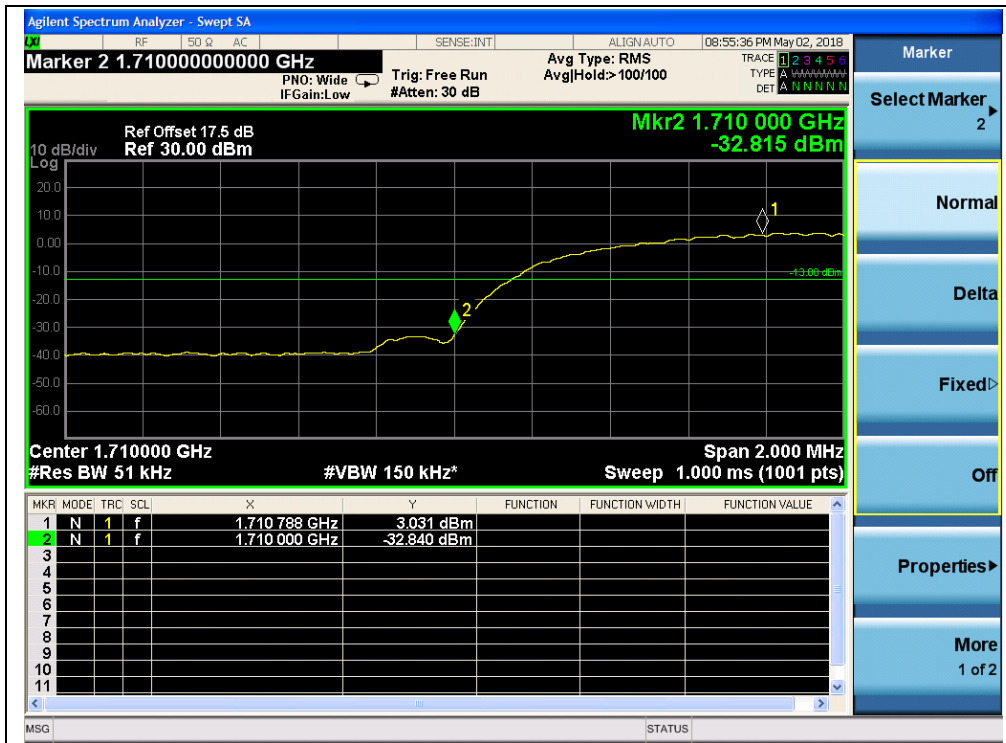

(Plot O1, HSPA+ 1700, Channel = 1312)



(Plot O2, HSPA+ 1700, Channel = 1513)

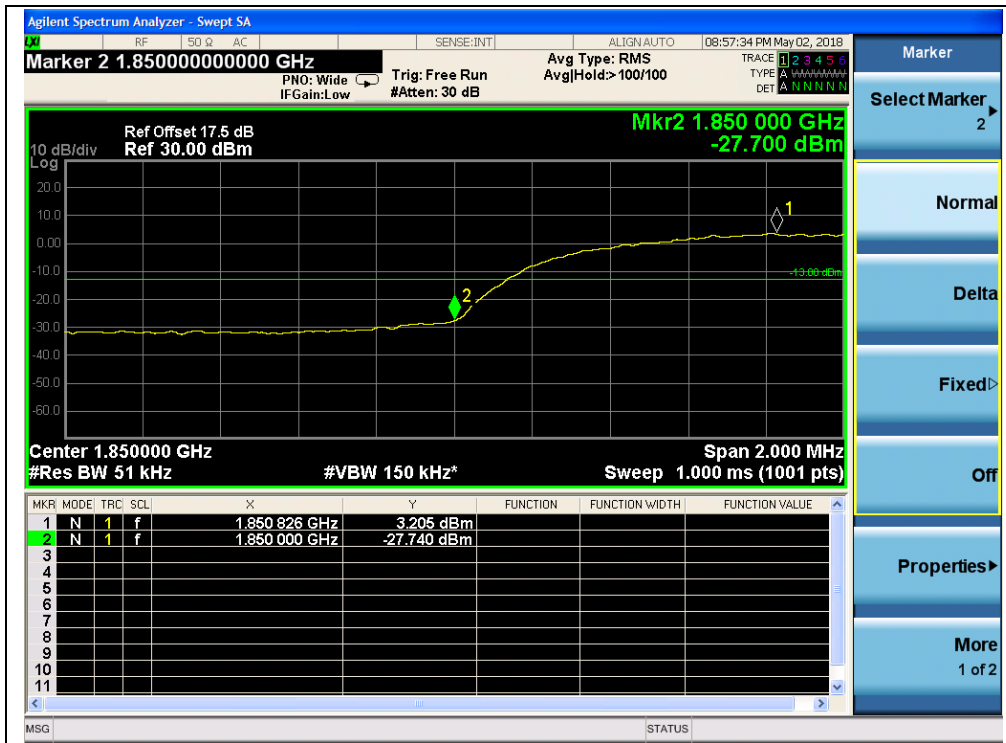

(Plot P1, HSPA+ 1900, Channel = 9262)



(Plot P2, HSPA+ 1900, Channel = 9538)

## 2.7. Transmitter Radiated Power (EIRP/ERP)

### 2.7.1. Requirement

According to FCC section 22.913, the Effective Radiated Power (ERP) of mobile transmitters and auxiliary test transmitters must not exceed 7Watts.

According to FCC section 24.232, the broadband PCS mobile station is limited to 2 Watts e.i.r.p. peak power.

According to FCC section 27.50, mobile, and portable (hand-held) stations is limited to 1 Watts e.i.r.p. peak power.

### 2.7.2. Test Description

Test Setup:

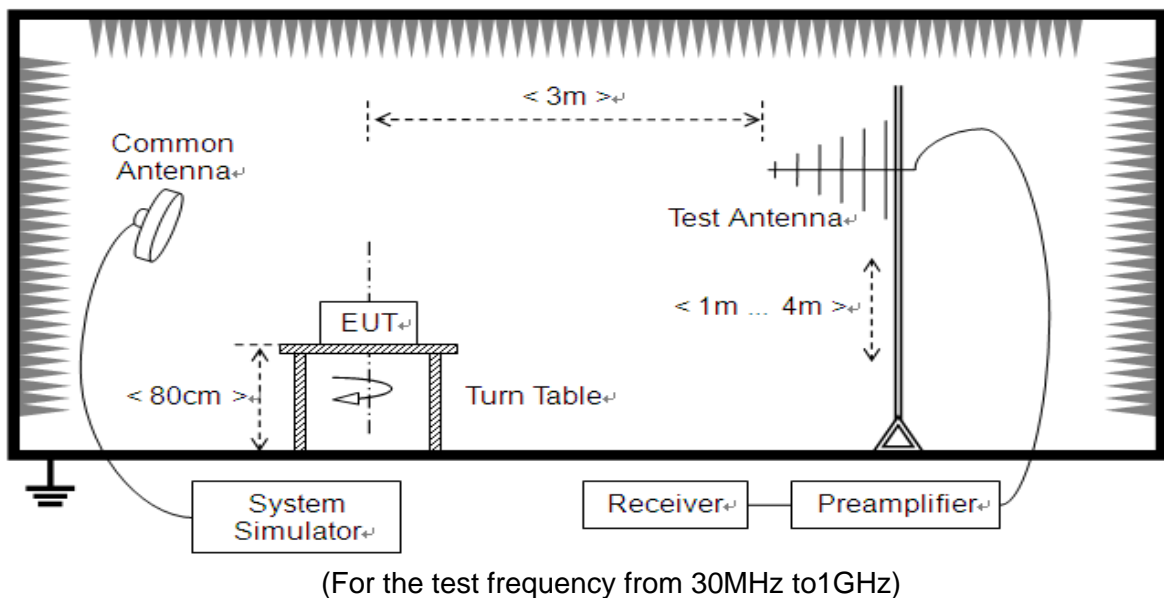

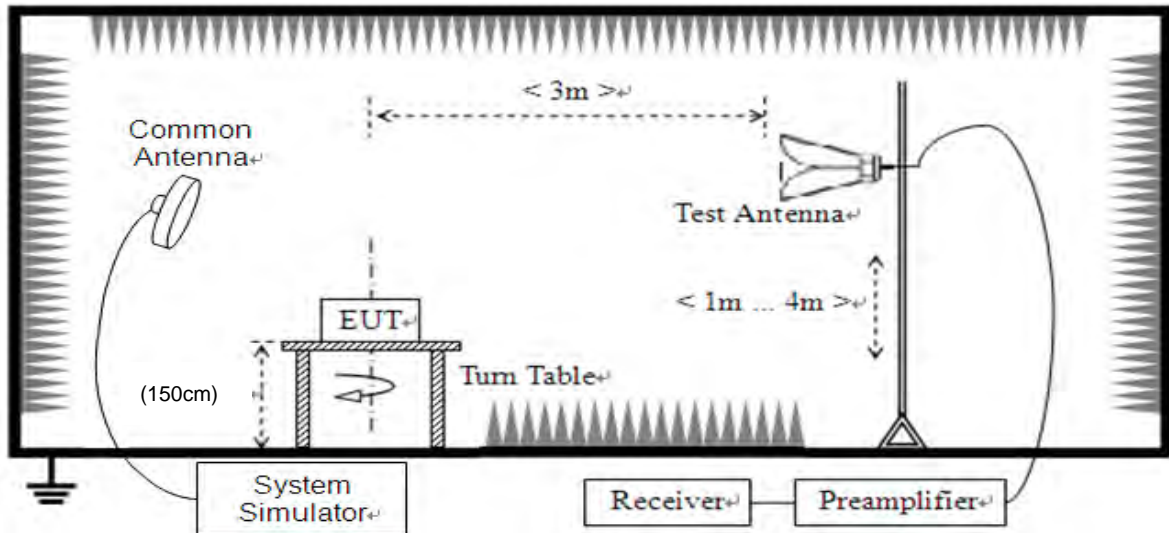

(For the test frequency above 1GHz)

The EUT is located in a 3m Full-Anechoic Chamber; the cable loss, air loss and so on of the site as factors are pre-calibrated using the "Substitution" method, and calculated to correct the reading. A call is established between the EUT and the SS via a Common Antenna. The EUT is commanded by the SS to operate at the maximum and minimum output power (i.e. GSM850MHz band Power Control Level (PCL) = 5/19 and Power Class = 4, GSM1900MHz band Power Control Level (PCL) = 0/15 and Power Class = 1), and only the test result of the maximum output power was recorded. Please refer to section 2.1.3 of this report.

- Step size (dB): 3dB

The Test Antenna is a Bi-Log one (used for 30MHz to 1GHz) or a Horn one (used for above 3GHz), it's located at the same height as the EUT. The Filters consists of Notch Filters and High Pass Filter.



### 2.7.3. Test Result

The Turn Table is actuated to turn from 0° to 360°, and both horizontal and vertical polarizations of the Test Antenna are used to find the maximum radiated power. The lowest, middle and highest channels are tested.

The substitution corrections are obtained as described below:

$$A_{\text{SUBST}} = P_{\text{SUBST\_TX}} - P_{\text{SUBST\_RX}} - L_{\text{SUBST\_CABLES}} + G_{\text{SUBST\_TX\_ANT}}$$

$$A_{\text{TOT}} = L_{\text{CABLES}} + A_{\text{SUBST}}$$

Where  $A_{\text{SUBST}}$  is the final substitution correction including receive antenna gain.

$P_{\text{SUBST\_TX}}$  is signal generator level,

$P_{\text{SUBST\_RX}}$  is receiver level,

$L_{\text{SUBST\_CABLES}}$  is cable losses including TX cable,

$G_{\text{SUBST\_TX\_ANT}}$  is substitution antenna gain.

$A_{\text{TOT}}$  is total correction factor including cable loss and substitution correction

During the test, the data of  $A_{\text{TOT}}$  was added in the Test Spectrum Analyze, so Spectrum Analyze reading is the final values which contain the data of  $A_{\text{TOT}}$ .





**GSM Test verdict:**

Band	Channel	Frequency (MHz)	PCL	Measured ERP			Limit		Verdict
				dBm	W	Refer to Plot	dBm	W	
GSM 850MHz	128	824.20	5	33.74	2.37	Plot A	38.5	7	PASS
	190	836.60	5	32.22	1.67				PASS
	251	848.80	5	32.32	1.71				PASS
GPRS 850MHz	128	824.20	5	33.25	2.11	Plot B <sup>Note 1</sup>	38.5	7	PASS
	190	836.60	5	32.55	1.80				PASS
	251	848.80	5	33.20	2.09				PASS
EGPRS 850MHz	128	824.20	5	33.03	2.01	Plot C <sup>Note 1</sup>	38.5	7	PASS
	190	836.60	5	32.41	1.74				PASS
	251	848.80	5	32.18	1.65				PASS
GSM 1900MHz	512	1850.2	0	28.47	0.70	Plot D	33	2	PASS
	661	1880.0	0	28.51	0.71				PASS
	810	1909.8	0	26.69	0.47				PASS
GPRS 1900MHz	512	1850.2	0	27.93	0.62	Plot E <sup>Note 1</sup>	33	2	PASS
	661	1880.0	0	26.73	0.47				PASS
	810	1909.8	0	27.14	0.52				PASS
EGPRS 1900MHz	512	1850.2	0	26.98	0.50	Plot F <sup>Note 1</sup>	33	2	PASS
	661	1880.0	0	26.54	0.45				PASS
	810	1909.8	0	25.53	0.36				PASS

Note 1: For the GPRS and EGPRS model, all the slots were tested and just the worst data were recorded in this report.

Note 2: Both horizontal and vertical polarizations of the test antenna are evaluated respectively, only the worst data (horizontal) were recorded in this report.



Test Plots:

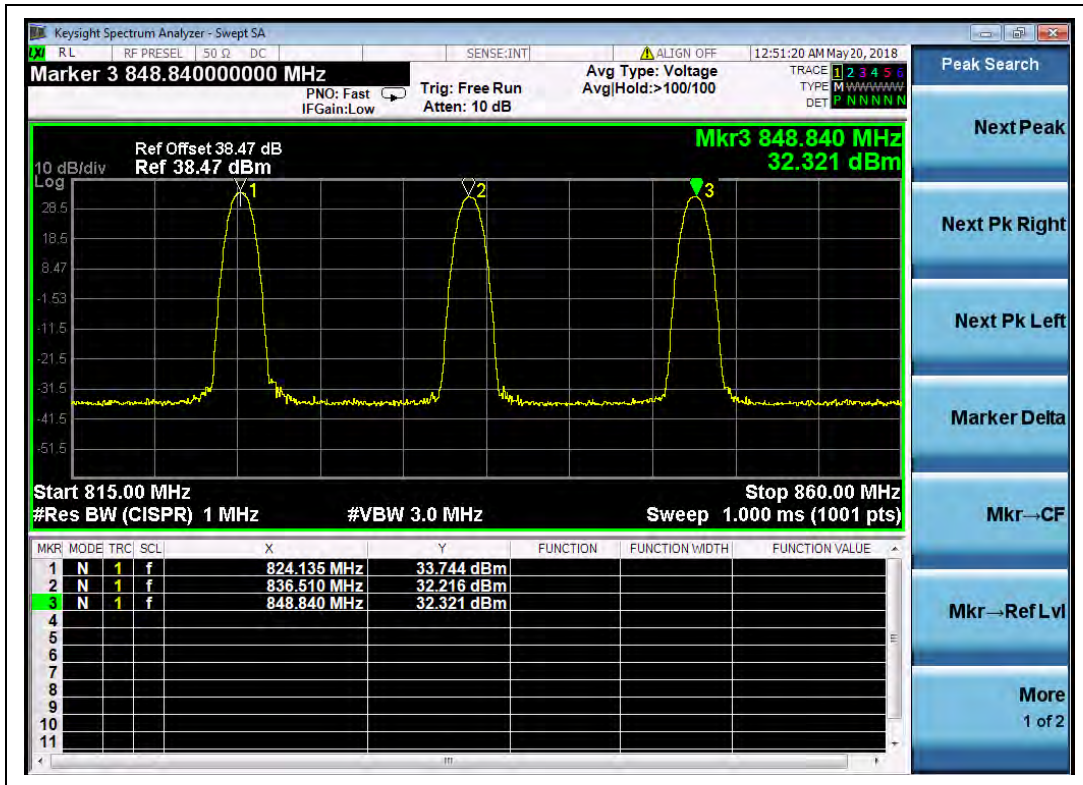

(Plot A, GSM 850MHz, Channel = 128, 190, 251)

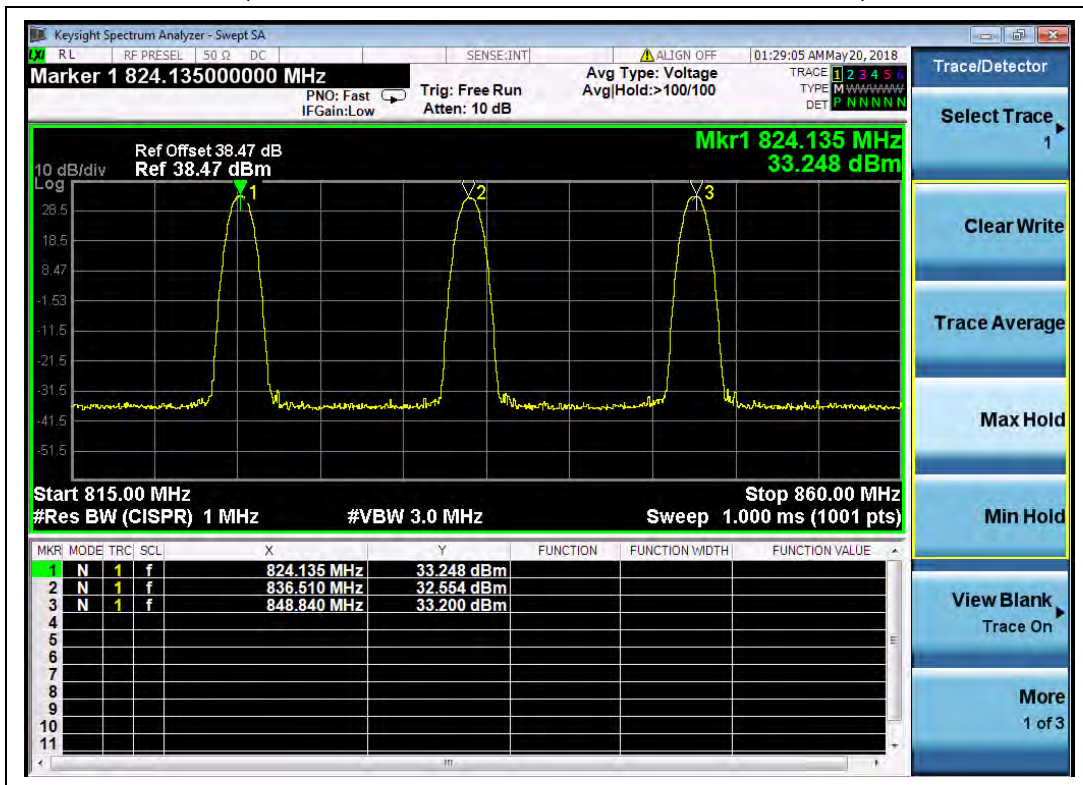

(Plot B, GPRS 850MHz, Channel = 128, 190, 251)

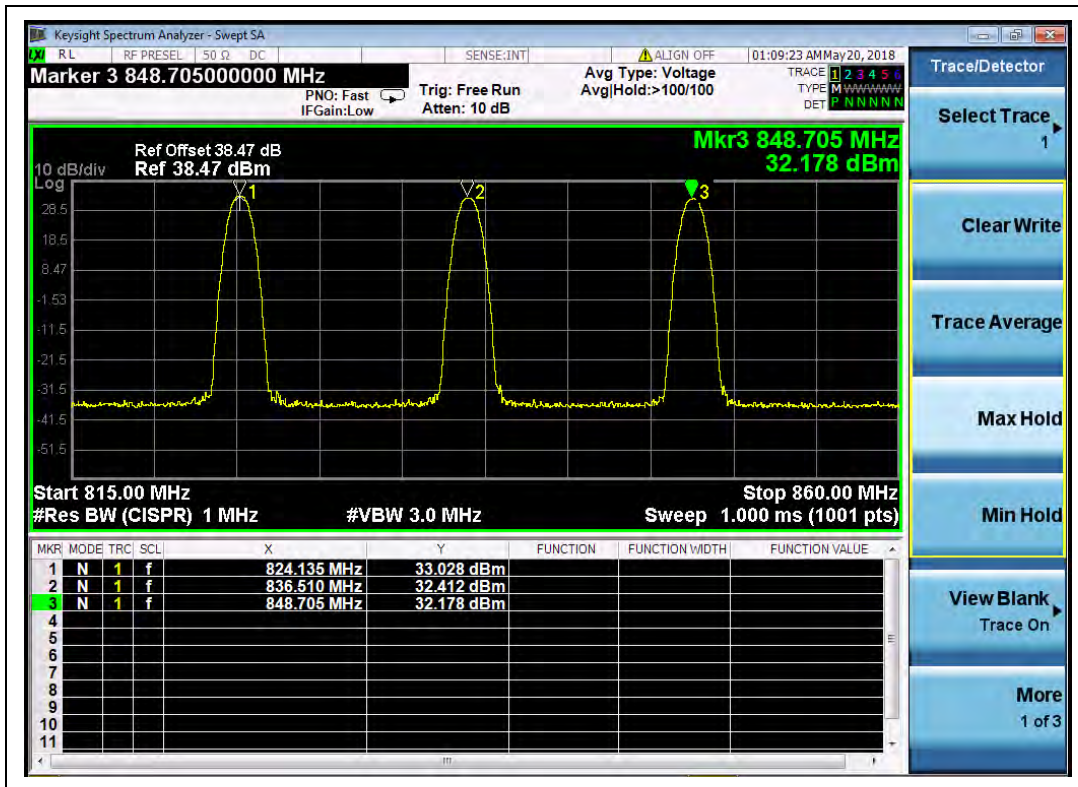

(Plot C, EGPRS 850MHz, Channel = 128, 190, 251)

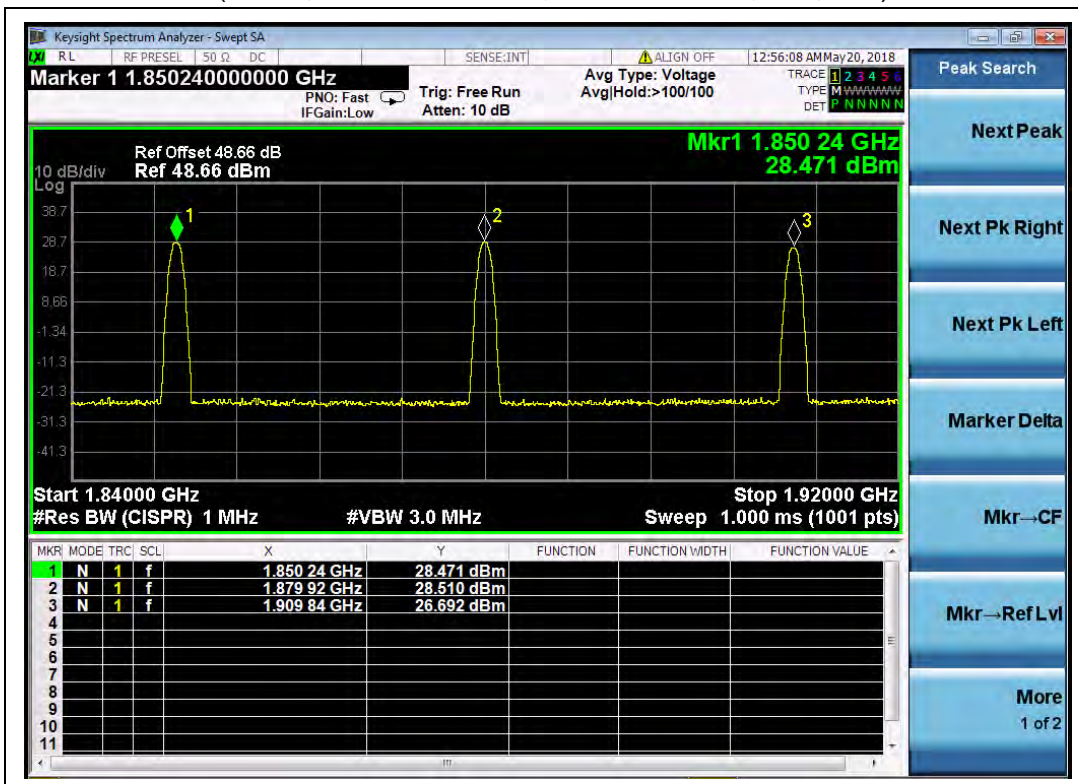

(Plot D, GSM 1900MHz, Channel = 512, 661, 810)

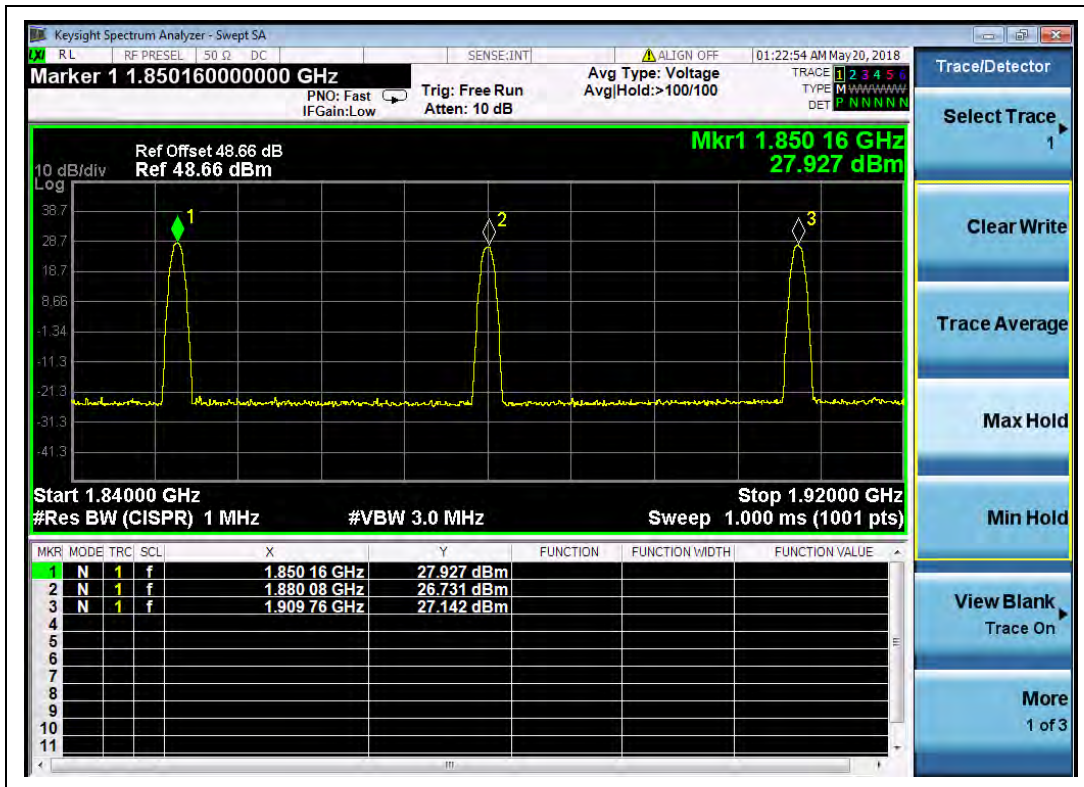

(Plot E, GPRS 1900MHz, Channel = 512, 661, 810)

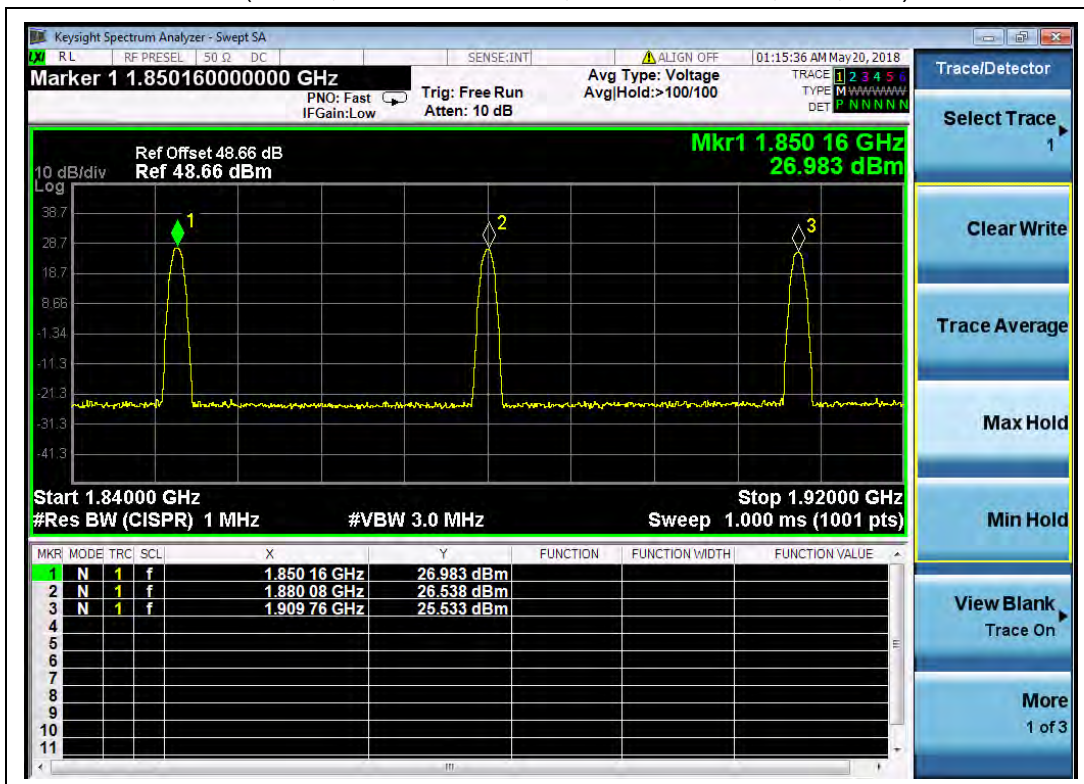

(Plot F, EGPRS 1900MHz, Channel = 512, 661, 810)



**WCDMA Test verdict:**

Band	Channel	Frequency (MHz)	Measured ERP			Limit		Verdict
			dBm	W	Refer to Plot	dBm	W	
WCDMA 850MHz	4132	826.4	27.24	0.53	Plot G	38.5	7	PASS
	4175	835.0	27.31	0.54				PASS
	4233	846.6	27.68	0.59				PASS
HSDPA 850MHz	4132	826.4	27.57	0.57	Plot H	38.5	7	PASS
	4175	835.0	27.84	0.61				PASS
	4233	846.6	27.10	0.51				PASS
HSUPA 850MHz	4132	826.4	27.66	0.58	Plot I	38.5	7	PASS
	4175	835.0	27.30	0.54				PASS
	4233	846.6	27.47	0.56				PASS
HSPA+ 850MHz	4132	826.4	27.84	0.61	Plot J	38.5	7	PASS
	4175	835.0	27.14	0.52				PASS
	4233	846.6	27.44	0.55				PASS
WCDMA 1900MHz	9262	1852.4	25.09	0.32	Plot K	33	2	PASS
	9400	1880.0	25.30	0.34				PASS
	9538	1907.6	25.78	0.38				PASS
HSDPA 1900MHz	9262	1852.4	25.35	0.34	Plot L	33	2	PASS
	9400	1880.0	25.28	0.34				PASS
	9538	1907.6	25.41	0.35				PASS
HSUPA 1900MHz	9262	1852.4	25.36	0.34	Plot M	33	2	PASS
	9400	1880.0	25.23	0.33				PASS
	9538	1907.6	25.15	0.33				PASS
HSPA+ 1900MHz	9262	1852.4	25.37	0.34	Plot N	33	2	PASS
	9400	1880.0	25.48	0.35				PASS
	9538	1907.6	25.54	0.36				PASS

Band	Channel	Frequency (MHz)	Measured EIRP			Limit		Verdict
			dBm	W	Refer to Plot	dBm	W	
WCDMA 1700MHz	1312	1712.4	26.29	0.43	Plot O	30	1	PASS
	1412	1732.4	26.13	0.41				PASS
	1513	1752.6	26.10	0.41				PASS
HSDPA 1700MHz	1312	1712.4	24.74	0.30	Plot P	30	1	PASS
	1412	1732.4	25.24	0.33				PASS
	1513	1752.6	24.85	0.31				PASS
HSUPA 1700MHz	1312	1712.4	25.49	0.35	Plot Q	30	1	PASS
	1412	1732.4	25.56	0.36				PASS
	1513	1752.6	25.00	0.32				PASS
HSPA+ 1700MHz	1312	1712.4	25.29	0.34	Plot R	30	1	PASS
	1412	1732.4	25.24	0.33				PASS
	1513	1752.6	24.86	0.31				PASS

Note 1: Both horizontal and vertical polarizations of the test antenna are evaluated respectively, only the worst data (horizontal) were recorded in this report.

**Test Plot**

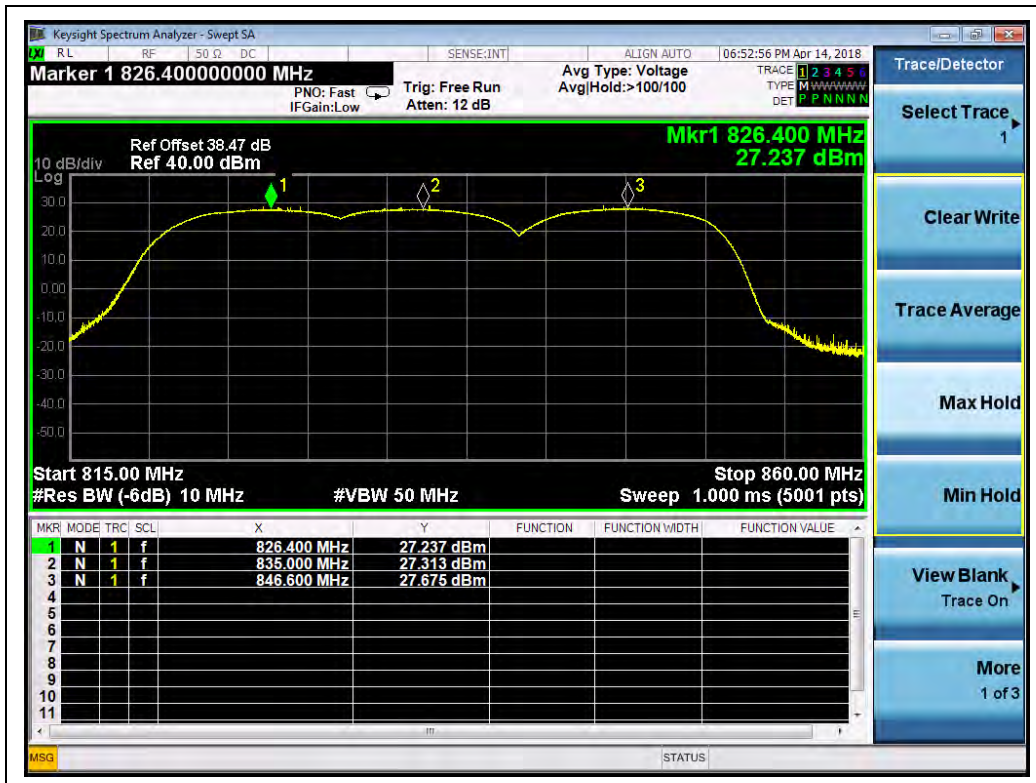

(Plot G, WCDMA 850 MHz, Channel = 4132, 4175, 4233)

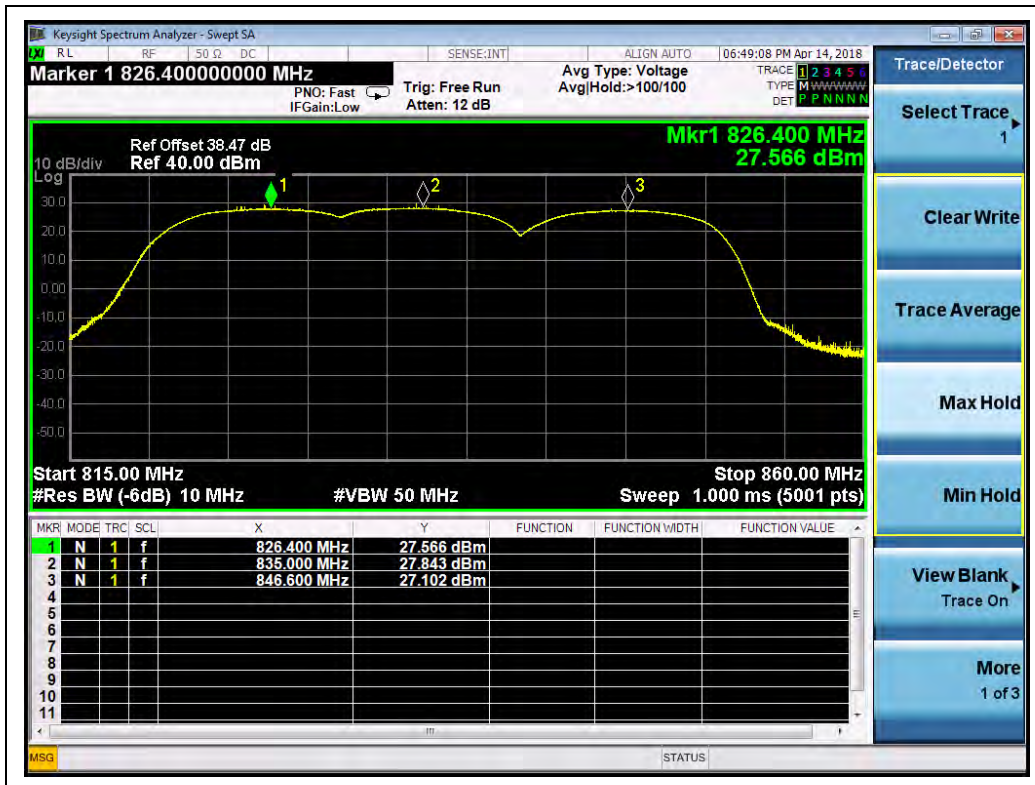

(Plot H, HSDPA 850 MHz, Channel = 4132, 4175, 4233)

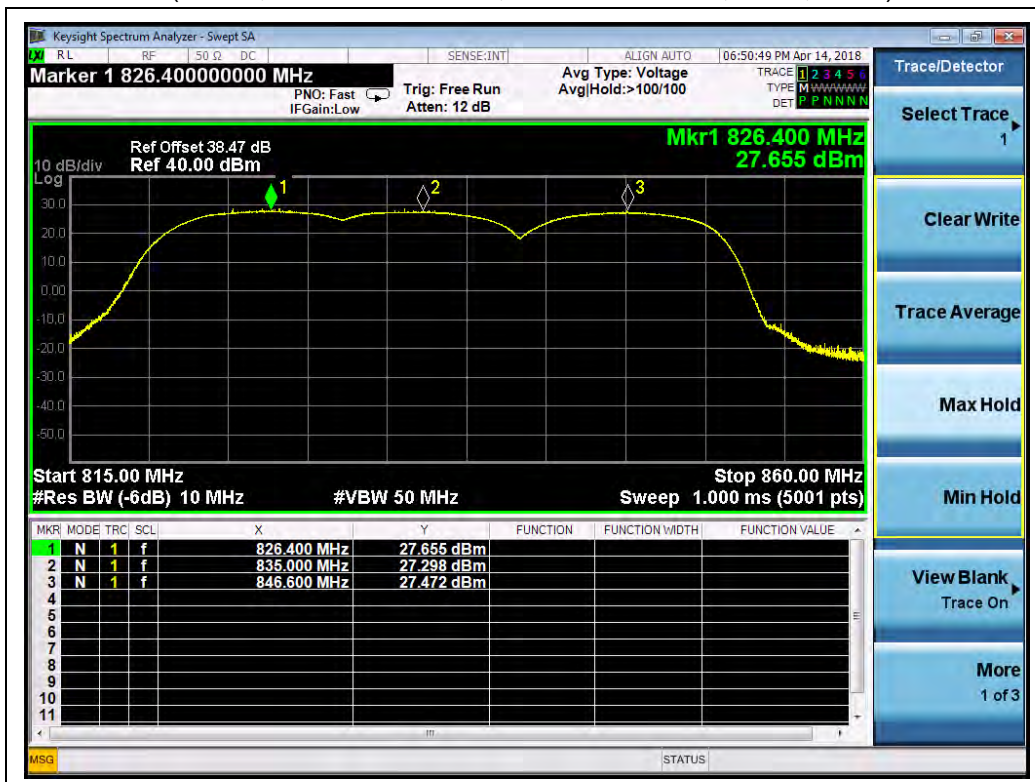

(Plot I, HSUPA 850 MHz, Channel = 4132, 4175, 4233)

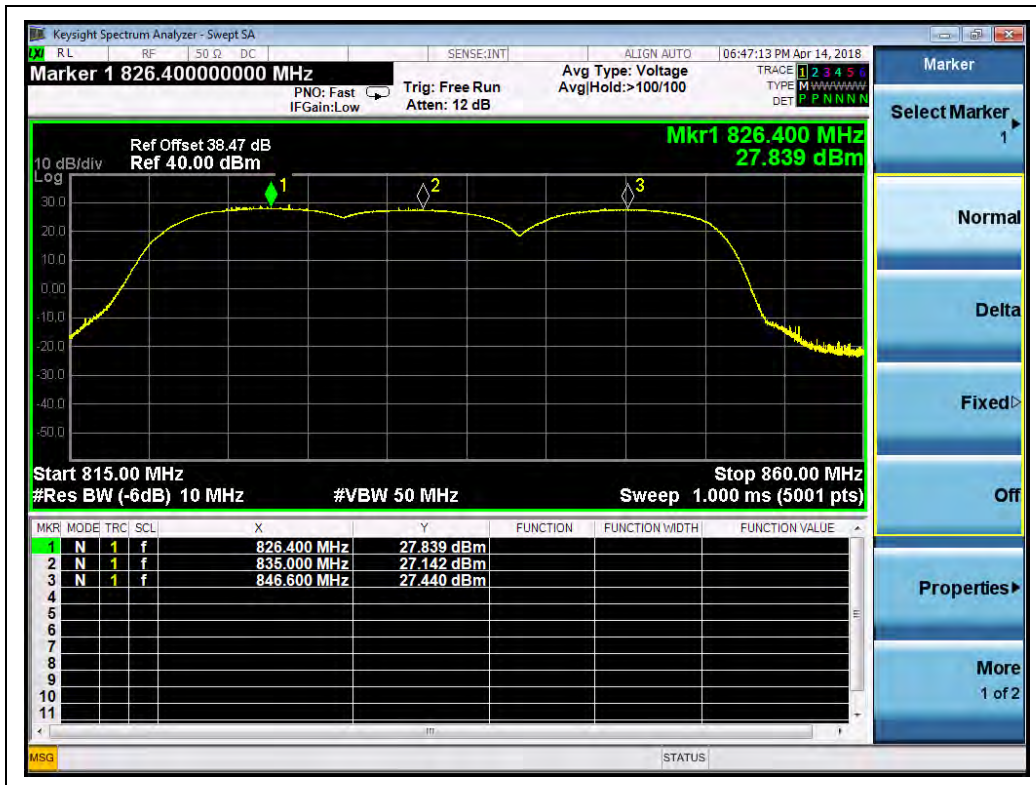

(Plot J, HSPA+ 850 MHz, Channel = 4132, 4175, 4233)

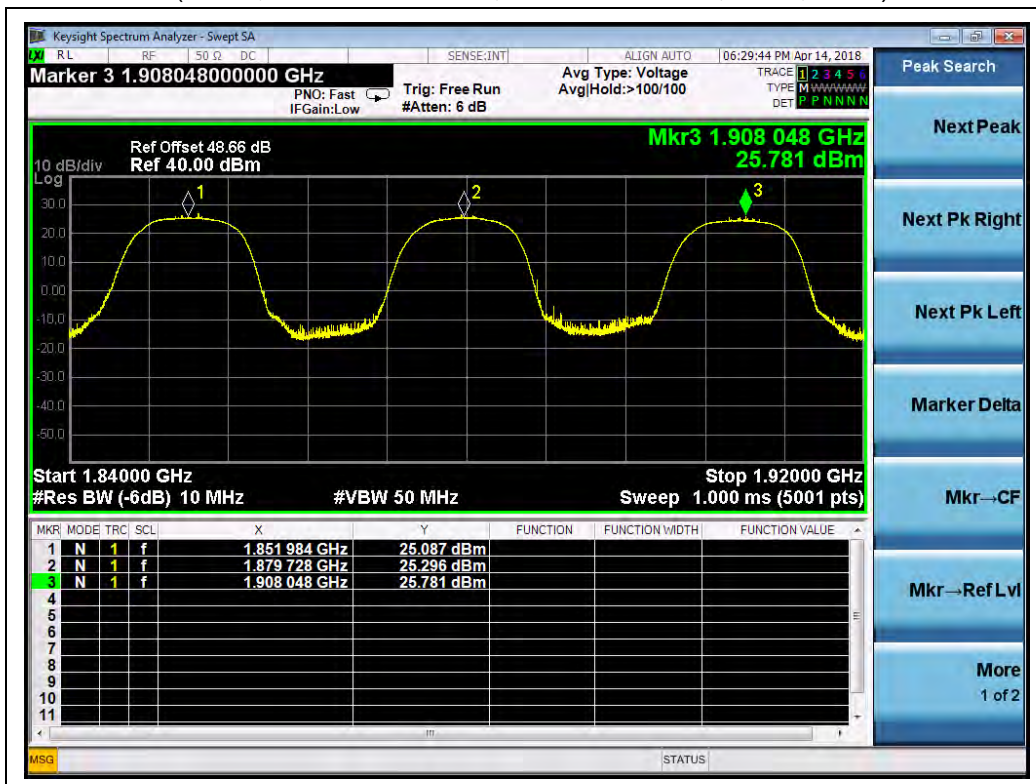

(Plot K, WCDMA 1900 MHz, Channel = 9262, 9400, 9538)



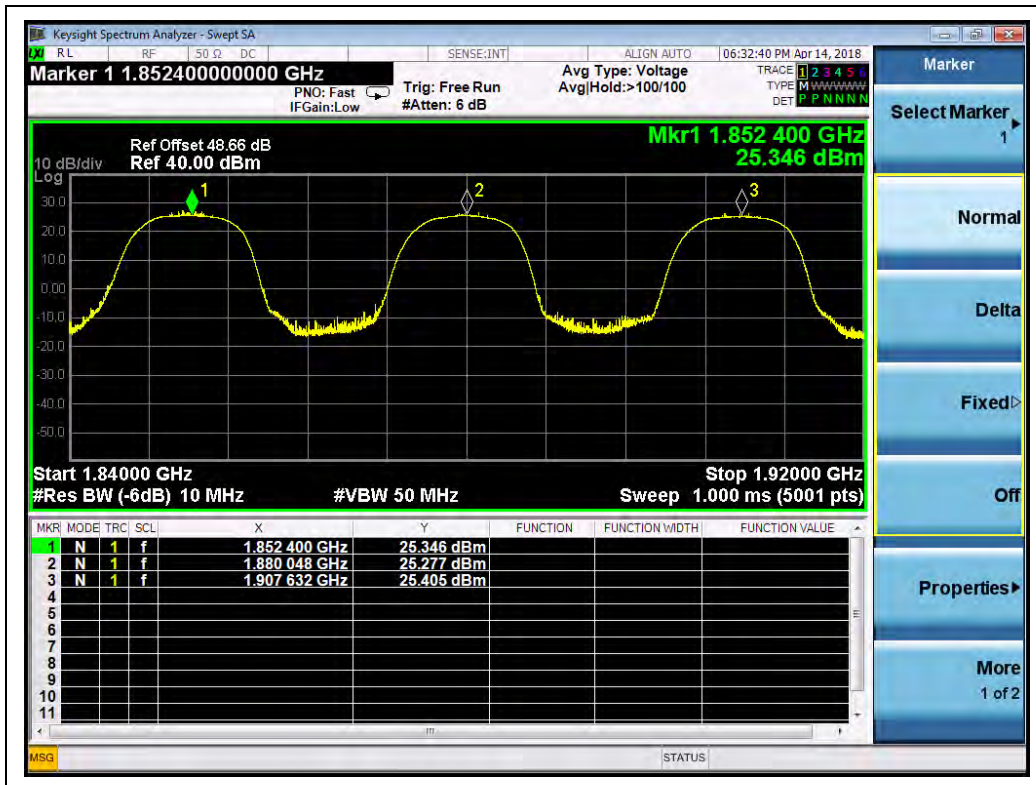

(Plot L, HSDPA1900 MHz, Channel = 9262, 9400, 9538)

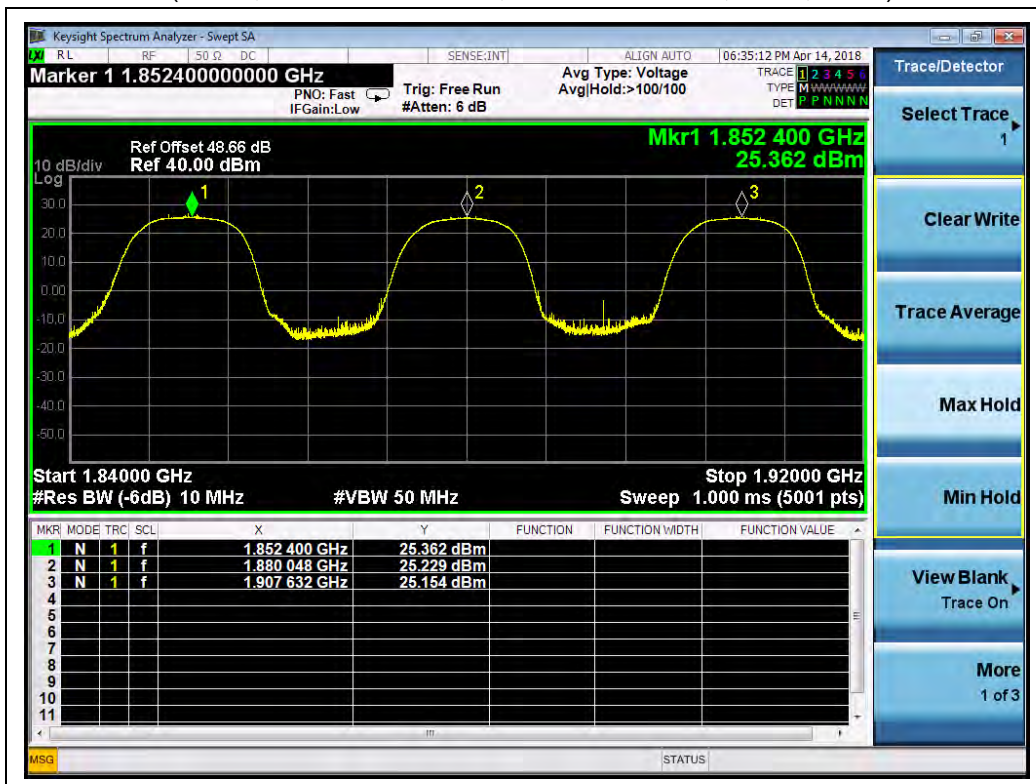

(Plot M, HSUPA1900 MHz, Channel = 9262, 9400, 9538)

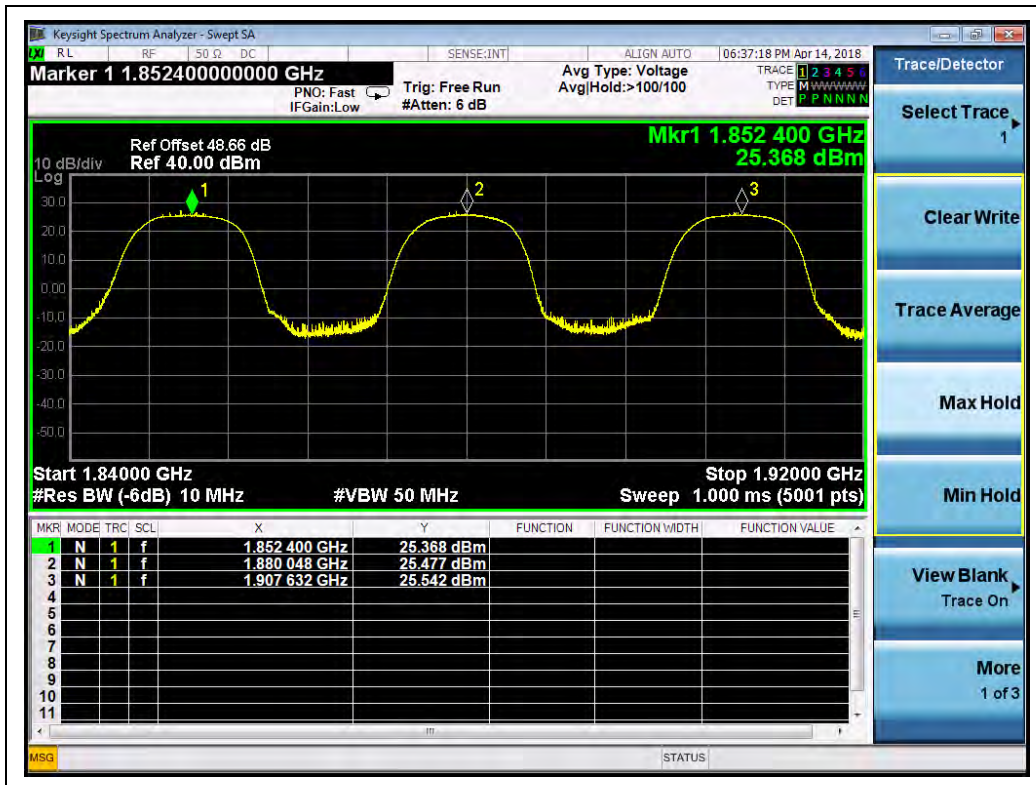

(Plot N, HSPA+ 1900 MHz, Channel = 9262, 9400, 9538)

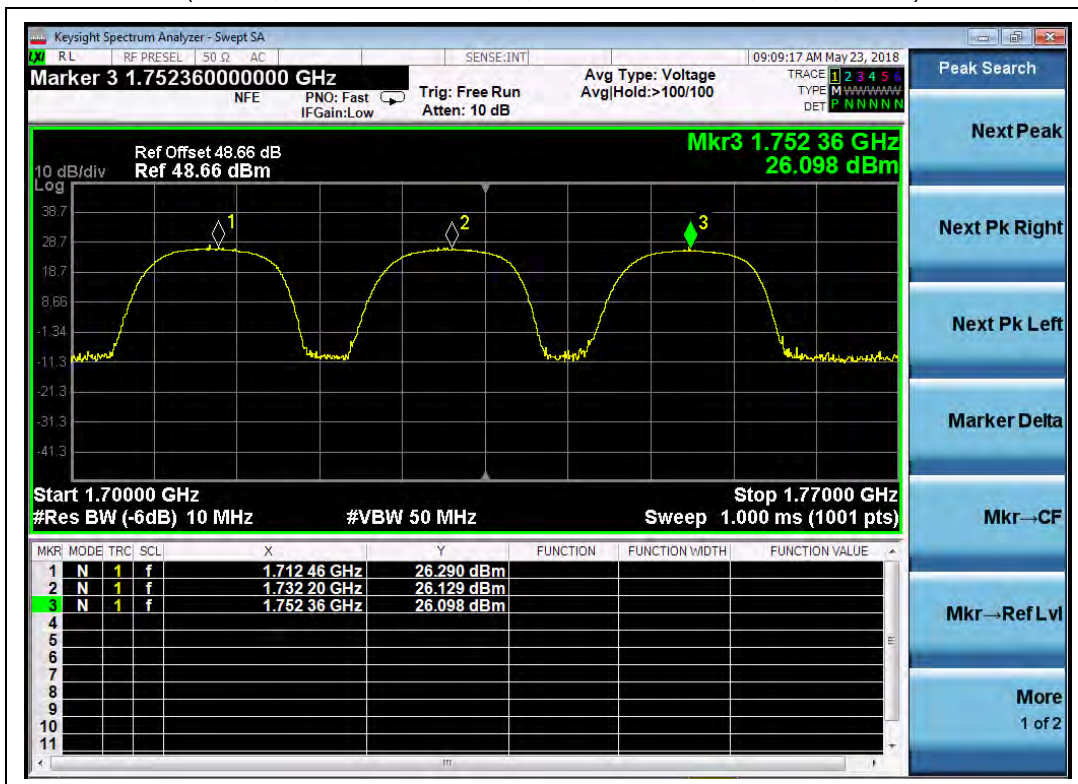

(Plot O, WCDMA 1700 MHz, Channel = 1312, 1412, 1513)

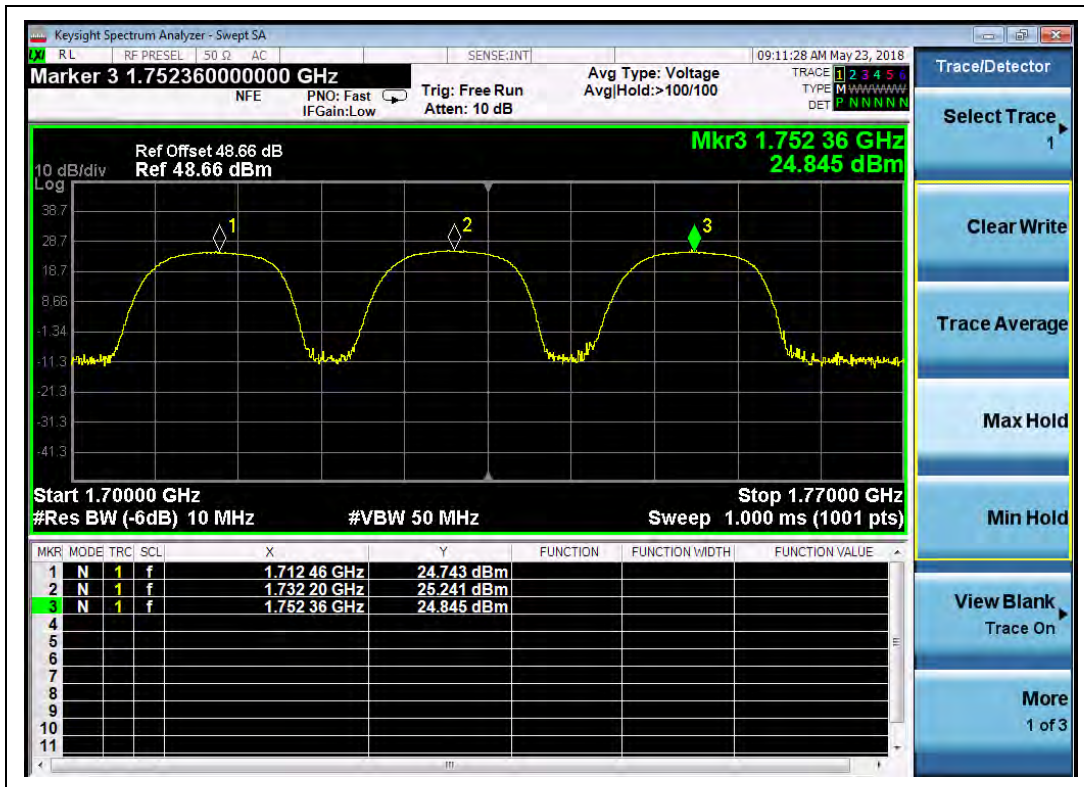

(Plot P, HSDPA1700 MHz, Channel = 1312, 1412, 1513)

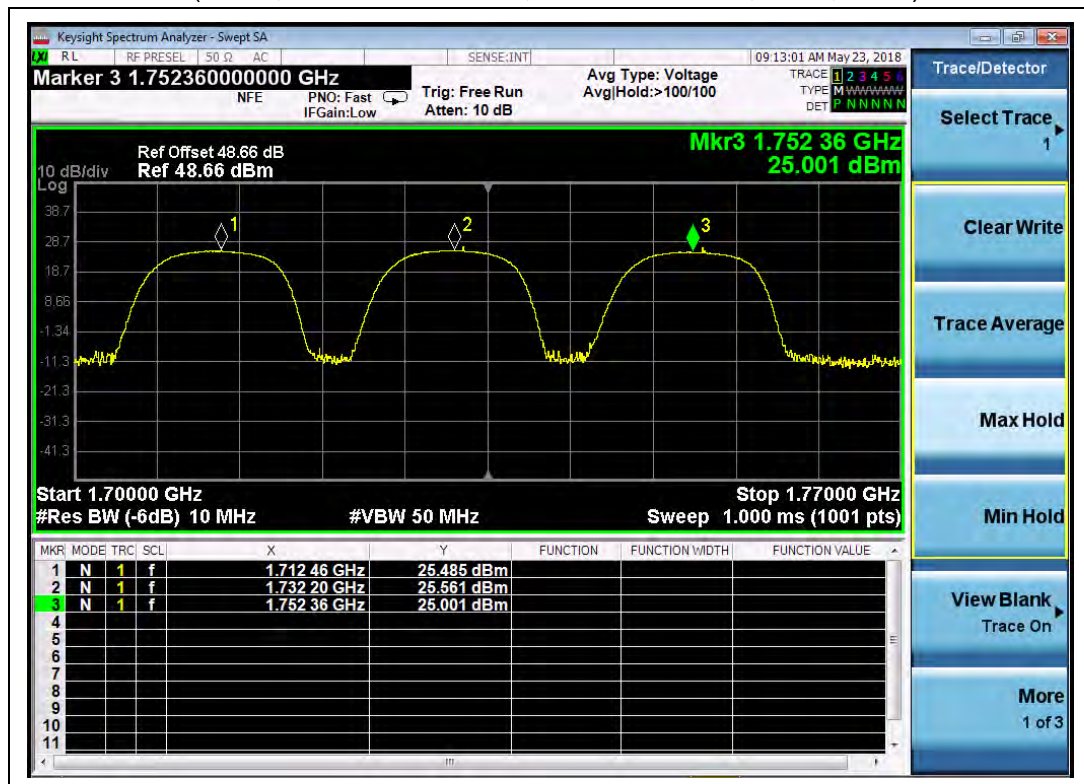

(Plot Q, HSUPA1700 MHz, Channel = 1312, 1412, 1513)

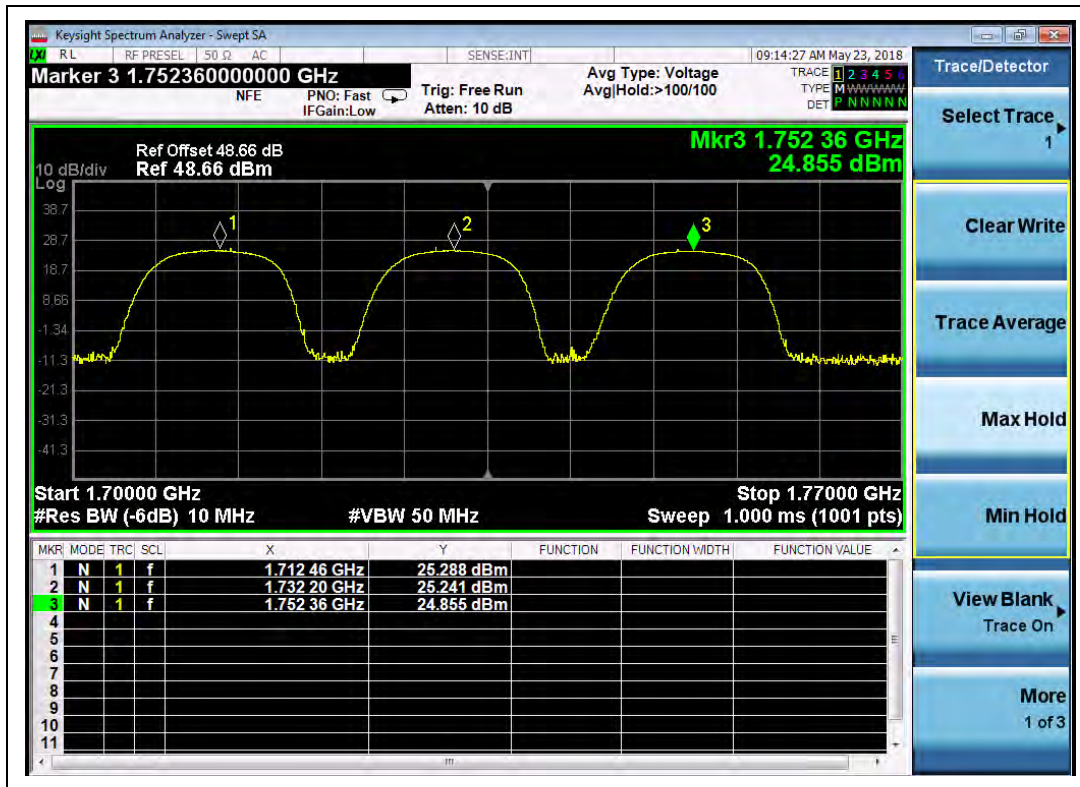

(Plot R, HSPA+1700 MHz, Channel = 1312, 1412, 1513)

## 2.8. Radiated Out of Band Emissions

### 2.8.1. Requirement

The power of any emission outside of the authorized operating frequency ranges must be attenuated below the transmitting power (P) by a factor of at least  $43+10*\log(P)$ dB. This calculated to be -13dBm.

### 2.8.2. Test Description

Test Setup:

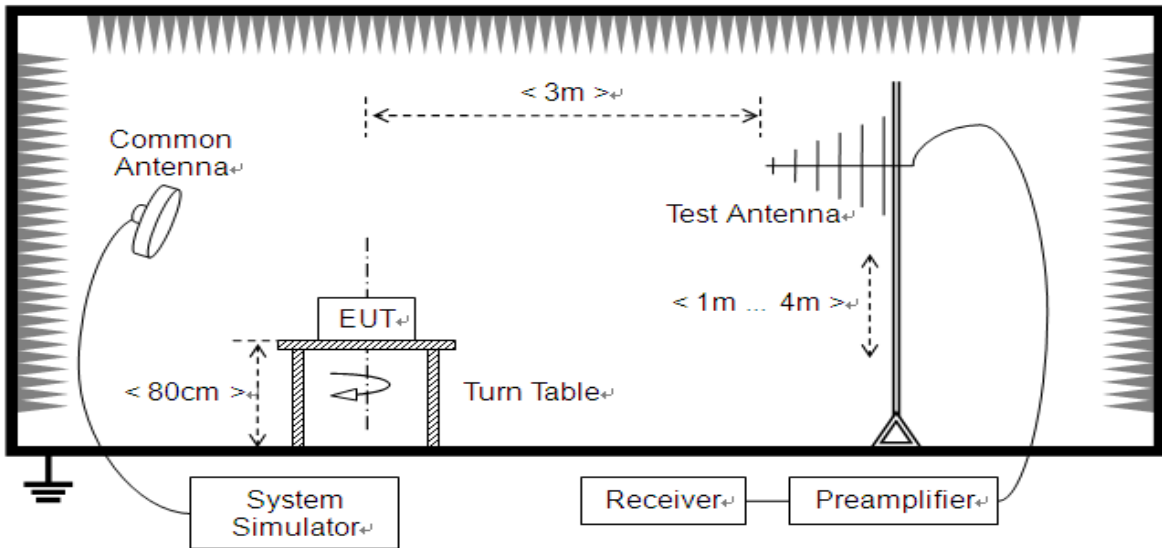

(For the test frequency from 30MHz to 1GHz)

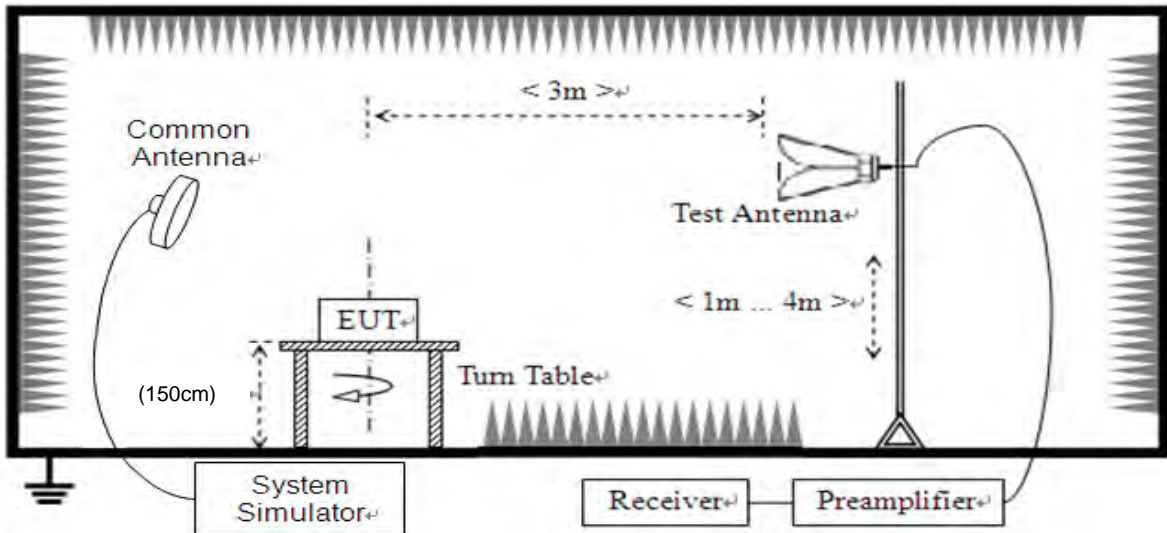

(For the test frequency above 1GHz)

The EUT is located in a 3m Full-Anechoic Chamber, the cable loss, air loss and so on of the site as factors are pre-calibrated using the "Substitution" method, and calculated to correct the reading. A call is established between the EUT and the SS via a Common Antenna. The EUT is commanded by the SS to operate at the maximum and minimum output power (i.e. GSM850MHz band Power Control Level (PCL) = 5/19 and Power Class = 4, GSM1900MHz band Power Control Level (PCL) = 0/15 and Power Class = 1), and only the test result of the maximum output power was recorded. Please refer to section 2.1.3 of this report.

- Step size (dB): 3dB

The Test Antenna is a Bi-Log one (used for 30MHz to 1GHz) and a Horn one (used for above 3 GHz), it's located at the same height as the EUT. The Filters consists of Notch Filters and High Pass Filter.

Note: when doing measurements above 1GHz, the EUT has been within the 3dB cone width of the horn antenna during horizontal antenna.



**2.8.3. Test Result**

The measurement frequency range is from 30MHz to the 10th harmonic of the fundamental frequency. The Turn Table is actuated to turn from 0° to 360°, and both horizontal and vertical polarizations of the Test Antenna are used to find the maximum radiated power. The lowest, middle and highest channels are tested to verify the out of band emissions. The power of the EUT transmitting frequency should be ignored.

**Note 1:** All test mode and condition mentioned were considered and evaluated respectively by performing full test, only the worst data were recorded and reported.

**Note 2:** All Spurious Emission tests were performed in X, Y, Z axis direction. And only the worst axis test condition was recorded in this test report.

**A. Test Verdict:**

Band	Channel	Frequency (MHz)	Measured Max. Spurious Emission (dBm)		Refer to Plot	Limit (dBm)	Verdict
			Test Antenna Horizontal	Test Antenna Vertical			
GSM 850MHz	128	824.2	< -25	< -25	Plot A1/A2	-13	PASS
	190	836.6	< -25	< -25	Plot A3/A4		PASS
	251	848.8	< -25	< -25	Plot A5/A6		PASS
GSM 1900MHz	512	1850.2	< -25	< -25	Plot B1/B2	-13	PASS
	661	1880.0	< -25	< -25	Plot B3/B4		PASS
	810	1909.8	< -25	< -25	Plot B5/B6		PASS
EGPRS 850MHz	128	824.2	< -25	< -25	Plot C1/C2	-13	PASS
	190	836.6	< -25	< -25	Plot C3/C4		PASS
	251	848.8	< -25	< -25	Plot C5/C6		PASS
EGPRS 1900MHz	512	1850.2	< -25	< -25	Plot D1/D2	-13	PASS
	661	1880.0	< -25	< -25	Plot D3/D4		PASS
	810	1909.8	< -25	< -25	Plot D5/D6		PASS
WCDMA 850MHz	4132	826.4	< -25	< -25	Plot E1/E2	-13	PASS
	4175	835.0	< -25	< -25	Plot E3/E4		PASS
	4233	846.6	< -25	< -25	Plot E5/E6		PASS
WCDMA 1700MHz	1312	1712.4	< -25	< -25	Plot F1/F2	-13	PASS
	1412	1732.4	< -25	< -25	Plot F3/F4		PASS
	1513	1752.6	< -25	< -25	Plot F5/F6		PASS
WCDMA 1900MHz	9262	1852.4	< -25	< -25	Plot G1/G2	-13	PASS
	9400	1880.0	< -25	< -25	Plot G3/G4		PASS
	9538	1907.6	< -25	< -25	Plot G5/G6		PASS

**B. Test Plots**

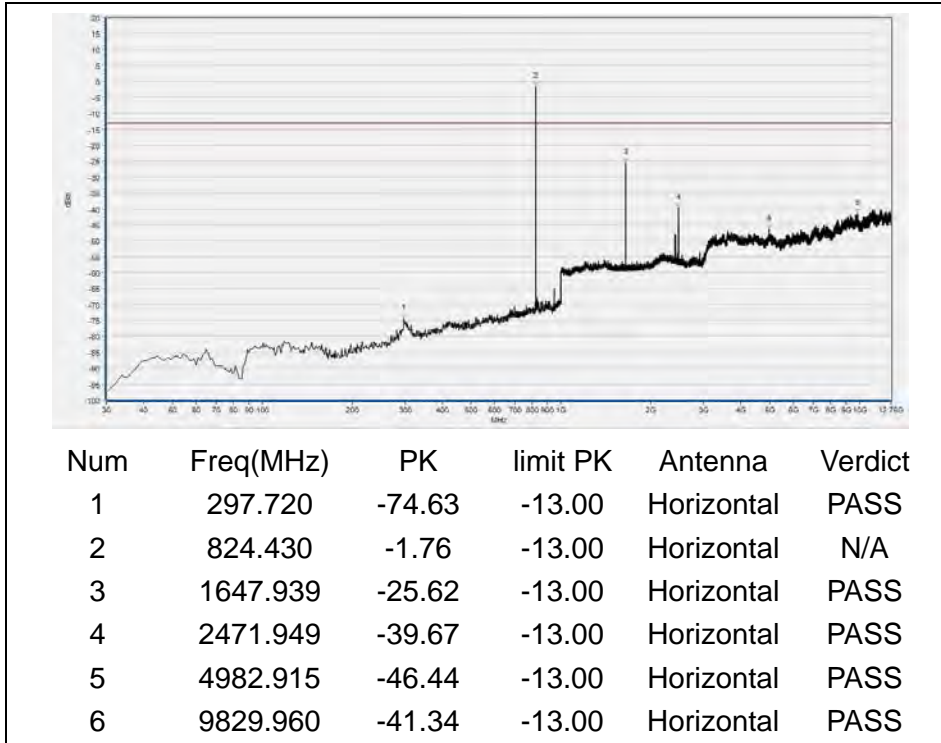

(Plot A1, GSM 850MHz, Channel = 128, Horizontal)

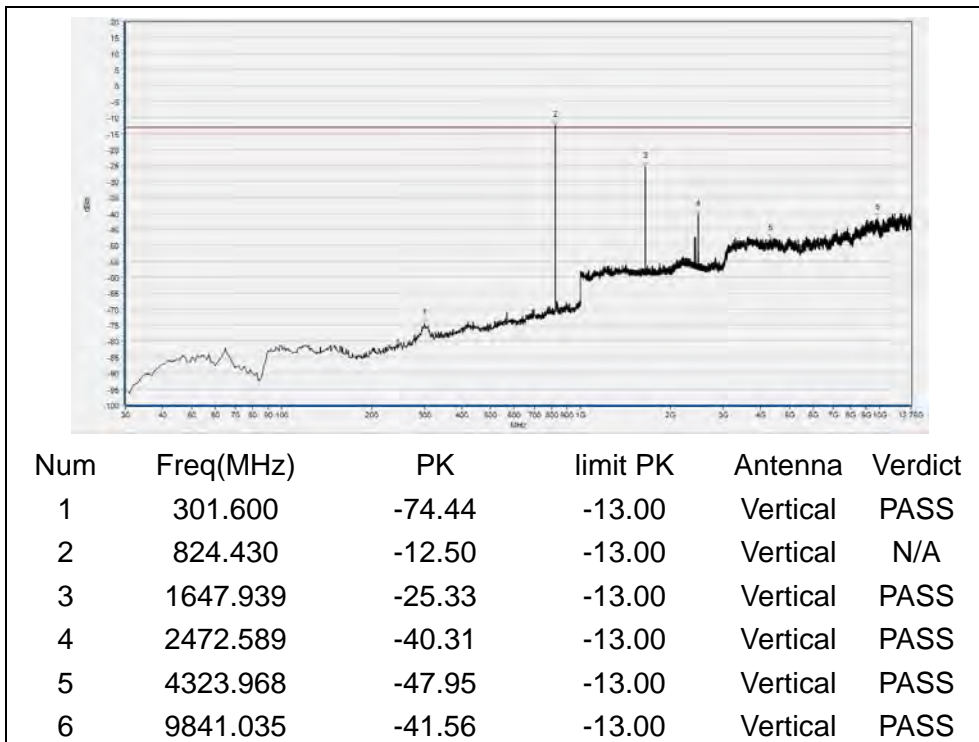

(Plot A2, GSM 850MHz, Channel = 128, Vertical)



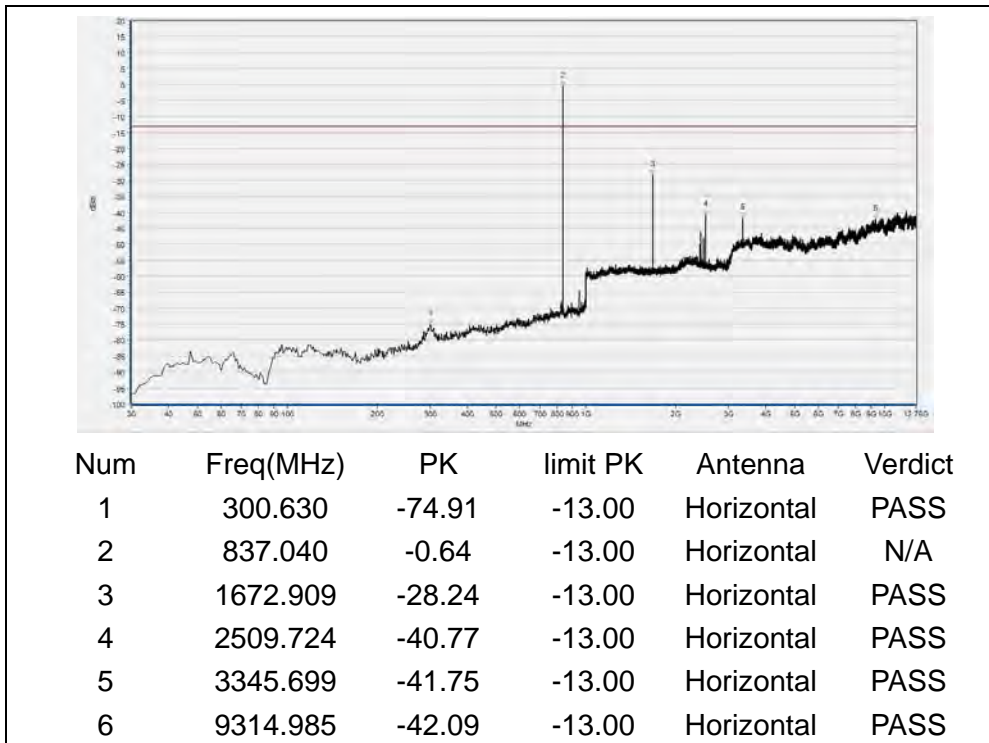

(Plot A3, GSM850MHz, Channel = 190, Horizontal)

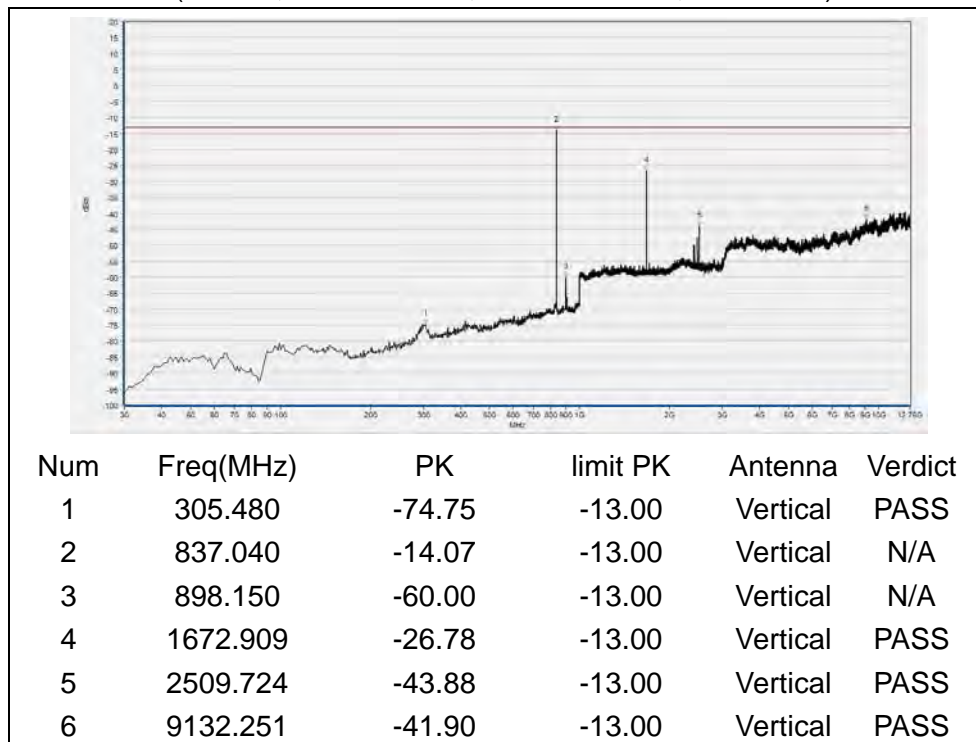

(Plot A4, GSM 850MHz, Channel = 190, Vertical)

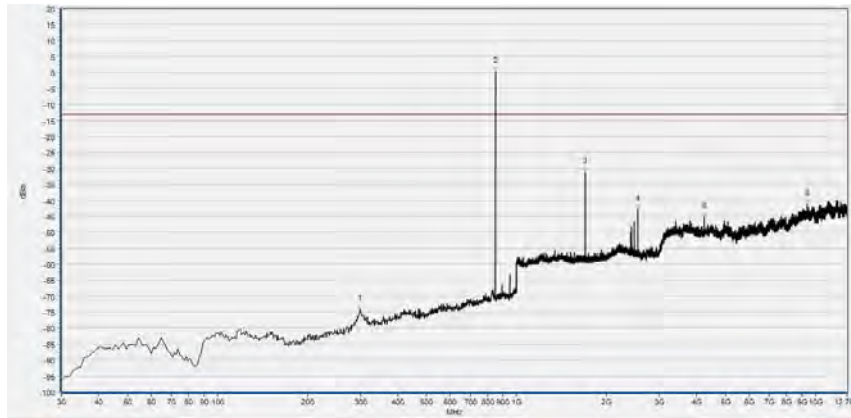

Num	Freq(MHz)	PK	limit PK	Antenna	Verdict
1	299.660	-74.00	-13.00	Horizontal	PASS
2	848.680	0.26	-13.00	Horizontal	N/A
3	1697.239	-31.26	-13.00	Horizontal	PASS
4	2546.218	-42.70	-13.00	Horizontal	PASS
5	4244.599	-45.23	-13.00	Horizontal	PASS
6	9344.517	-41.19	-13.00	Horizontal	PASS

(Plot A5, GSM 850MHz, Channel = 251, Horizontal)

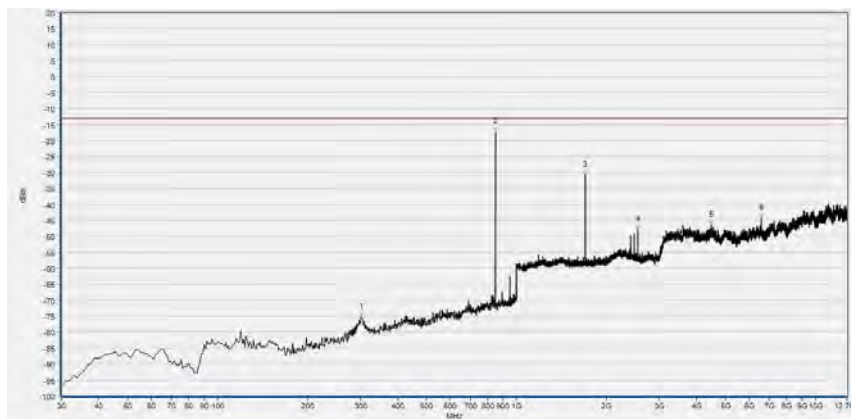

Num	Freq(MHz)	PK	limit PK	Antenna	Verdict
1	302.570	-75.30	-13.00	Vertical	PASS
2	848.680	-17.25	-13.00	Vertical	N/A
3	1697.239	-31.03	-13.00	Vertical	PASS
4	2546.218	-47.94	-13.00	Vertical	PASS
5	4473.477	-46.55	-13.00	Vertical	PASS
6	6570.295	-44.30	-13.00	Vertical	PASS

(Plot A6, GSM 850MHz, Channel = 251, Vertical)