



# SAR TEST REPORT

FCC ID..... :	2APBP-CS50	
Test Report No..... :	TCT211124E020	
Date of issue..... :	Dec. 27, 2021	
Testing laboratory .....	SHENZHEN TONGCE TESTING LAB	
Testing location/ address:	TCT Testing Industrial Park Fuqiao 5th Industrial Zone, Fuhai Street, Bao'an District Shenzhen, Guangdong, 518103, People's Republic of China	
Applicant's name..... :	Ciontek Technology Corp.	
Address..... :	B501, Chanxueyan Building Wuhan University, No.6 Of Yuexing 2nd Road, Yuehai Street, Nanshan District, Shenzhen, China	
Manufacturer's name ... :	Ciontek Technology Corp.	
Address..... :	B501, Chanxueyan Building Wuhan University, No.6 Of Yuexing 2nd Road, Yuehai Street, Nanshan District, Shenzhen, China	
Test item description .....	Smart POS Payment Terminal	
Trade Mark .....	Ciontek	
Model/Type reference..... :	CS50, CS50PRO, CS50LITE, CS50S, CS50V, CS50MINI, CS50A, CS50C, CS51, CS52	
SAR Max. Values..... :	<b>0.70 W/Kg (1g) for Body-worn; 0.72 W/Kg (1g) for Hotspot</b>	
Date of receipt of test item .....	Nov. 24, 2021	
Date (s) of performance of test..... :	Nov. 24, 2021 - Dec. 23, 2021	
Tested by (+signature) ... :	Karl WANG	
Check by (+signature).... :	Beryl ZHAO	
Approved by (+signature):	Tomsin	

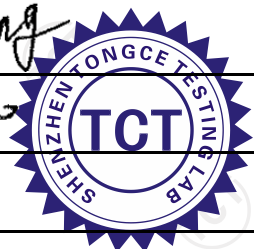

**General disclaimer:**

This report shall not be reproduced except in full, without the written approval of SHENZHEN TONGCE TESTING LAB. This document may be altered or revised by SHENZHEN TONGCE TESTING LAB personnel only, and shall be noted in the revision section of the document. The test results in the report only apply to the tested sample.

TABLE OF CONTENTS

1. General Product Information .....	4
1.1. EUT description .....	4
1.2. Model(s) list .....	5
2. Test standard.....	6
3. Facilities and Accreditations .....	6
3.1. Facilities.....	6
3.2. Location .....	6
3.3. Environment Condition:.....	6
4. Test Result Summary .....	7
5. RF Exposure Limit .....	8
6. SAR Measurement System Configuration .....	9
6.1. SAR Measurement Set-up.....	9
6.2. E-field Probe.....	10
6.3. Phantom.....	10
6.4. Device Holder .....	11
6.5. Data Storage and Evaluation.....	12
6.6. Position of the wireless device in relation to the phantom .....	13
6.7. Tissue Dielectric Parameters .....	16
6.8. Tissue-equivalent Liquid Properties .....	17
6.9. System Check .....	18
7. Measurement Procedure .....	19
8. Conducted Output Power.....	22
9. Exposure Position Consideration .....	39
9.1. EUT Antenna Location .....	39
9.2. Test Position Consideration.....	39
10. SAR Test Results Summary.....	40
10.1.Body-Worn 1g SAR Data.....	40
10.2.Hotspot 1g SAR Data.....	42
10.3.Simultaneous Transmission Conclusion.....	45
10.4.SAR Simultaneous Transmission Analysis.....	47
10.5.Measurement Uncertainty (450MHz-3GHz).....	51
10.6.Test Equipment List .....	53
11. System Check Results .....	54
12. SAR Test Data .....	68
Appendix A: EUT Photos.....	124
Appendix B: Test Setup Photos .....	126
Appendix C: Probe Calibration Certificate .....	128

**Appendix D: Dipole Calibration Report ..... 145**  
**Appendix E: SAR SYSTEM VALIDATION..... 212**  
**Appendix F: The Check Data of Impedance and Return Loss ..... 213**



# 1. General Product Information

## 1.1. EUT description

Test item description.....:	Smart POS Payment Terminal
Model/Type reference.....:	CS50
Sample Number.....:	TCT211124E020-0101
Rating(s).....:	Rechargeable Li-ion Battery DC7.6V
<b>2G</b>	
Operation Band.....:	GSM850, GSM1900
Supported type.....:	GSM/GPRS/EGPRS
Power Class.....:	GSM850:Power Class 5; GSM1900:Power Class 0
Modulation Type.....:	GMSK for GSM/GPRS; 8QPSK for EGPRS
GSM Release Version.....:	R99
GPRS Multislot Class.....:	12
EGPRS Multislot Class.....:	N/A
<b>3G</b>	
Operation Band.....:	FDD Band II & FDD Band IV & FDD Band V
Power Class.....:	Power Class 3
Modulation Type.....:	QPSK for WCDMA/HSDPA/HSUPA
WCDMA Release Version.....:	R99
HSDPA Release Version.....:	Release 5
HSUPA Release Version.....:	Release 6
DC-HSUPA Release Version.....:	Not Supported
<b>LTE</b>	
Operation Band.....:	LTE Band 2 & LTE Band 4 & LTE Band 5 & LTE Band 12 & LTE Band 17
Power Class.....:	Power Class 3
Modulation Type.....:	QPSK &16-QAM for LTE
<b>Wi-Fi 2.4G</b>	
Supported type.....:	802.11b/802.11g/802.11n
Modulation Type.....:	802.11b: DSSS 802.11g/802.11n:OFDM
Operation Frequency.....:	802.11b/802.11g/802.11n(HT20):2412MHz~2462MHz; 802.11n(HT40):2422MHz~2452MHz
Channel number.....:	802.11b/802.11g/802.11n(HT20):11; 802.11n(HT40):7
Channel separation.....:	5MHz

Bluetooth	
Bluetooth Version.....:	Supported 5.0
Modulation.....:	GFSK(1Mbps) , $\pi/4$ -DQPSK(2Mbps) , 8-DPSK(3Mbps)
Operation Frequency.....:	2402MHz~2480MHz
Channel number.....:	79/40
Channel separation.....:	1MHz/2MHz
Wi-Fi 5G	
Operation Frequency.....:	Band 1: 5180 MHz -5240 MHz Band 4: 5745 MHz -5825 MHz
Channel Bandwidth.....:	802.11a: 20MHz 802.11n: 20MHz, 40MHz 802.11ac: 20MHz, 40MHz, 80MHz
Modulation Technology.....:	Orthogonal Frequency Division Multiplexing(OFDM)
Modulation Type.....:	256QAM, 64QAM, 16QAM, BPSK, QPSK

### 1.2. Model(s) list

No.	Model No.	Tested with
1	CS50	<input checked="" type="checkbox"/>
Other models	CS50, CS50PRO, CS50LITE, CS50S, CS50V, CS50MINI, CS50A, CS50C, CS51, CS52	<input type="checkbox"/>

Note: CS50 is tested model, other models are derivative models. The models are identical in circuit and PCB layout, only different on the model names. So the test data of CS50 can represent the remaining models.

## 2. Test standard

The tests were performed according to following standards:

FCC 47 CFR §2.1093

IEEE1528-2013:Recommended Practice for Determining the Peak Spatial-Average Specific Absorption Rate in the Human Head from Wireless Communications Devices: Measurement Techniques

KDB447498 D01:General RF Exposure Guidance v06

KDB865664 D01:SAR measurement 100MHz to 6GHz v01r04

KDB865664 D02:RF Exposure Reporting v01r02.

KDB941225 D01:3G SAR Procedures v03r01

KDB248227 D01:802.11 wi-fi SAR v02r02

KDB941225 D05:SAR for LTE devices v02r05

KDB941225 D06:Hotspot Mode v02r01

KDB941225 D07:UMPC Mini Tablet v01r02

KDB690783 D01:SAR Listings on Grant v01r03

## 3. Facilities and Accreditations

### 3.1. Facilities

The test facility is recognized, certified, or accredited by the following organizations:

- FCC - Registration No.: 645098

SHENZHEN TONGCE TESTING LAB

Designation Number: CN1205

The testing lab has been registered and fully described in a report with the (FCC) Federal Communications Commission. The acceptance letter from the FCC is maintained in our files.

- IC - Registration No.: 10668A-1

SHENZHEN TONGCE TESTING LAB

CAB identifier: CN0031

The testing lab has been registered by Certification and Engineering Bureau of Industry Canada for radio equipment testing.

### 3.2. Location

SHENZHEN TONGCE TESTING LAB

Address: TCT Testing Industrial Park Fugiao 5th Industrial Zone, Fuhai Street, Bao'an District Shenzhen, Guangdong, 518103, People's Republic of China

### 3.3. Environment Condition:

Temperature:	18°C ~25°C
Humidity:	35%~75% RH
Atmospheric Pressure:	1011 mbar

### 4. Test Result Summary

The maximum results of Specific Absorption Rate (SAR) found during test as bellows:

<Highest Reported standalone SAR Summary>

Exposure Position	Frequency Band	Reported SAR (W/kg)	Equipment Class	Highest Reported SAR (W/kg)
Body-worn 1-g SAR (10 mm Gap)	GSM 850	0.67	PCE	0.70
	GSM 1900	0.58		
	WCDMA Band II	0.66		
	WCDMA Band IV	0.41		
	WCDMA Band V	0.20		
	LTE Band 2	0.52		
	LTE Band 4	<b>0.70</b>		
	LTE Band 5	0.33		
	LTE Band 12	0.15		
	LTE Band 17	0.22		
	5.2GWLAN	0.36	NII	
	5.8GWLAN	0.37		
	WLAN 2.4 GHz	0.23	DTS	
Hotspot 1-g SAR (10 mm Gap)	GSM 850	0.69	PCE	0.72
	GSM 1900	0.60		
	WCDMA Band II	0.68		
	WCDMA Band IV	0.44		
	WCDMA Band V	0.21		
	LTE Band 2	0.57		
	LTE Band 4	<b>0.72</b>		
	LTE Band 5	0.37		
	LTE Band 12	0.17		
	LTE Band 17	0.25		
	5.2GWLAN	0.38	NII	
	5.8GWLAN	0.40		
	WLAN 2.4 GHz	0.24	DTS	

<Highest Reported simultaneous SAR Summary>

Exposure Position	Frequency Band	Highest Reported Simultaneous Transmission SAR (W/kg)
Body 1-g SAR (10 mm Gap)	LTE Band 4 + WIFI 5G	<b>1.07</b>
Hotspot 1-g SAR (10 mm Gap)	LTE Band 4 + WIFI 5G	<b>1.12</b>

**Note:**

- The highest simultaneous transmission is scalar summation of Reported standalone SAR per FCC KDB 690783 D01 v01r03, and scalar SAR summation of all possible simultaneous transmission scenarios are < 1.6W/kg.
- This device is compliance with Specific Absorption Rate (SAR) for general population/uncontrolled exposure limits specified in FCC 47 CFR part 2 (2.1093) and ANSI/IEEE C95.1-2005, and had been tested in accordance with the measurement methods and procedures specified in IEEE 1528-2013.
- This EUT owns four cards, after we perform the pretest for these two SIM card; we found the SIM 1 is the worst case, so its result is recorded in this report.

## 5. RF Exposure Limit

Type Exposure	SAR (W/kg)
	Uncontrolled Exposure Limit
Spatial Peak SAR (averaged over any 1 g of tissue)	1.60
Spatial Peak SAR (hands/wrists/feet/ankles averaged over 10g)	4.00
Spatial Peak SAR (averaged over the whole body)	0.08
<b>Note:</b>	
1. The Spatial Peak value of the SAR averaged over any 1 gram of tissue (defined as a tissue volume in the shape of a cube) and over the appropriate averaging time.	
2. The Spatial Average value of the SAR averaged over the whole body.	
3. The Spatial Peak value of the SAR averaged over any 10 grams of tissue (defined as a tissue volume in the shape of a cube) and over the appropriate averaging time.	



## 6. SAR Measurement System Configuration

### 6.1. SAR Measurement Set-up

The OPENSAR system for performing compliance tests consist of the following items:

A standard high precision 6-axis robot (KUKA) with controller and software.

KUKA Control Panel (KCP)

A dosimetric probe, i.e., an isotropic E-field probe optimized and calibrated for usage in tissue simulating liquid. The probe is equipped with a Video Positioning System (VPS).

The stress sensor is composed with mechanical and electronic when the electronic part detects a change on the electro-mechanical switch; it sends an "Emergency signal" to the robot controller that to stop robot's moves A computer operating Windows XP.

OPENSAR software Remote control with teaches pendant and additional circuitry for robot safety such as warning lamps, etc.

The SAM phantom enabling testing left-hand right-hand and body usage.

The Position device for handheld EUT

Tissue simulating liquid mixed according to the given recipes.

System validation dipoles to validate the proper functioning of the system.

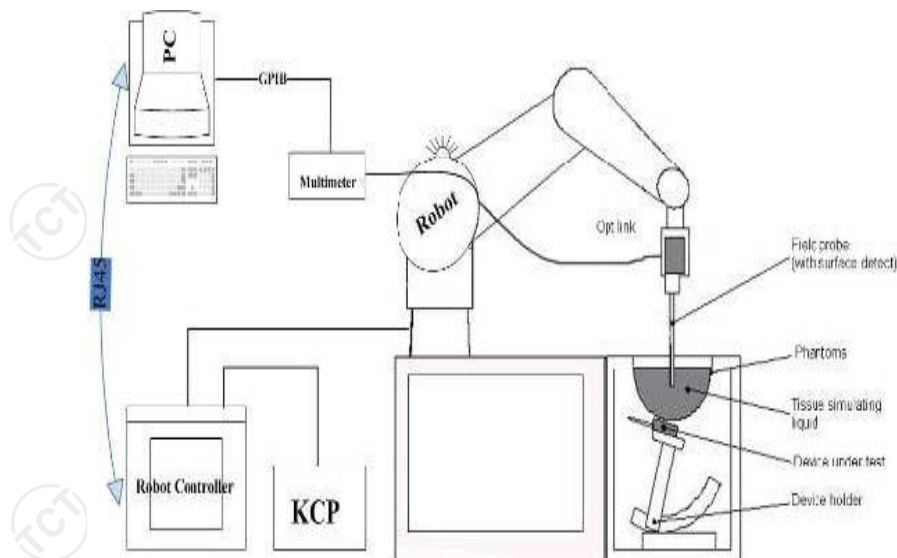

**KUKA SAR Test System Configuration**

## 6.2. E-field Probe

The SAR measurement is conducted with the dosimetric probe (manufactured by MVG). The probe is specially designed and calibrated for use in liquid with high permittivity. The dosimetric probe has special calibration in liquid at different frequency. This probe has a built in optical surface detection system to prevent from collision with phantom.

### Probe Specification

Construction Symmetrical design with triangular core  
Interleaved sensors  
Built-in shielding against static charges  
PEEK enclosure material (resistant to organic solvents, e.g., DGBE)  
Calibration ISO/IEC 17025 calibration service available.

Device Type	COMOSAR DOSIMETRIC E FIELD PROBE
Manufacturer	MVG
Model	SSE2
Serial Number	SN 36/20 EPGO346
Frequency Range of Probe	0.15 GHz-6GHz
Resistance of Three Dipoles at Connector	Dipole 1:R1=0.217MΩ Dipole 2:R3=0.245MΩ Dipole 3:R3=0.219MΩ

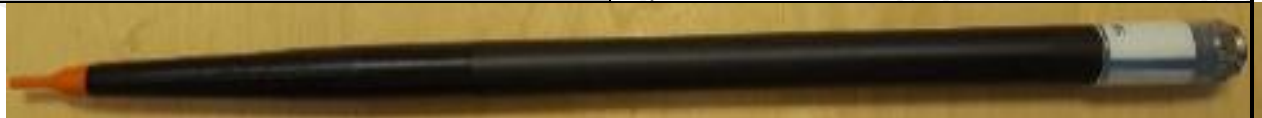

Photo of E-Field Probe

## 6.3. Phantom

The SAM Phantom SAM120 is constructed of a fiberglass shell integrated in a wooden table. The shape of the shell is in compliance with the specification set in IEEE P1528 and CENELEC IEC 62209-1, IEC 62209-2:2010.

The phantom enables the dosimetric evaluation of left and right hand phone usage as well as body mounted usage at the flat phantom region.

A cover prevents the evaporation of the liquid.

Reference markings on the Phantom allow the complete setup of all predefined phantom positions and measurement grids by manually teaching three points in the robot

System checking was performed using the flat section, whilst Head SAR tests used the left and right head profile sections.

Body SAR testing also used the flat section between the head profiles.

Name: COMOSAR IEEE SAM PHANTOM  
S/N: SN 19/15 SAM 120  
Manufacture: MVG



SAM Twin Phantom

#### 6.4. Device Holder

In combination with the Generic Twin Phantom SAM120, the Mounting Device enables the rotation of the mounted transmitter in spherical coordinates whereby the rotation points is the ear opening. The devices can be easily, accurately, and repeatedly positioned according to the FCC and CENELEC specifications. The device holder can be locked at different phantom locations (left head, right head, flat phantom).



COMOSAR Mobile  
phone positioning  
system

## 6.5. Data Storage and Evaluation

### Data Storage

The OPENSAR software stores the acquired data from the data acquisition electronics as raw data (in microvolt readings from the probe sensors), together with all necessary software parameters for the data evaluation (probe calibration data, liquid parameters and device frequency and modulation data) in measurement files. The software evaluates the desired unit and format for output each time the data is visualized or exported. This allows verification of the complete software setup even after the measurement and allows correction of incorrect parameter settings. For example, if a measurement has been performed with a wrong crest factor parameter in the device setup, the parameter can be corrected afterwards and the data can be re-evaluated.

The measured data can be visualized or exported in different units or formats, depending on the selected probe type ([V/m], [A/m], [°C], [mW/g], [mW/cm<sup>2</sup>], [dBrel], etc.). Some of these units are not available in certain situations or show meaningless results, e.g., a SAR output in a lossless media will always be zero. Raw data can also be exported to perform the evaluation with other software packages.

### Data Evaluation

The OPENSAR software automatically executes the following procedures to calculate the field units from the microvolt readings at the probe connector. The parameters used in the evaluation are stored in the configuration modules of the software:

Probe parameters:	- Sensitivity	Normi, ai0, ai1, ai2
	- Conversion factor	ConvFi
	- Diode compression point	Dcpi
Device parameters:	- Frequency	f
	- Crest factor	cf
Media parameters:	- Conductivity	σ
	- Density	ρ

These parameters must be set correctly in the software. They can be found in the component documents or they can be imported into the software from the configuration files issued for the OPENSAR components. In the direct measuring mode of the millimeter option, the parameters of the actual system setup are used. In the scan visualization and export modes, the parameters stored in the corresponding document files are used.

The first step of the evaluation is a linearization of the filtered input signal to account for the compression characteristics of the detector diode. The compensation depends on the input signal, the diode type and the DC-transmission factor from the diode to the evaluation electronics. If the exciting field is pulsed, the crest factor of the signal must be known to correctly compensate for peak power. The formula for each channel can be given as:

$$V_i = U_i + U_i^2 \cdot c f / d c p_i$$

With	$V_i$	= compensated signal of channel i	(i = x, y, z)
	$U_i$	= input signal of channel i	(i = x, y, z)
	cf	= crest factor of exciting field	(MVG parameter)
	dcpi	= diode compression point	(MVG parameter)

From the compensated input signals the primary field data for each channel can be evaluated:

$$\text{E-field probes: } E_i = (V_i / \text{Normi} \cdot \text{ConvF})^{1/2}$$

$$\text{H-field probes: } H_i = (V_i)^{1/2} \cdot (a_{i0} + a_{i1} f + a_{i2} f^2) / f$$

With	$V_i$	= compensated signal of channel i	(i = x, y, z)
	Normi	= sensor sensitivity of channel i	(i = x, y, z)
		[mV/(V/m) <sup>2</sup> ] for E-field Probes	
	ConvF	= sensitivity enhancement in solution	
	a <sub>ij</sub>	= sensor sensitivity factors for H-field probes	
	f	= carrier frequency [GHz]	
	$E_i$	= electric field strength of channel i in V/m	
	$H_i$	= magnetic field strength of channel i in A/m	

The RSS value of the field components gives the total field strength (Hermitian magnitude):

$$E_{tot} = (E_x^2 + E_y^2 + E_z^2)^{1/2}$$

The primary field data are used to calculate the derived field units.

$$SAR = (E_{tot})^2 \cdot \sigma / (\rho \cdot 1000)$$

- with SAR = local specific absorption rate in mW/g
- E<sub>tot</sub> = total field strength in V/m
- σ = conductivity in [mho/m] or [Siemens/m]
- ρ = equivalent tissue density in g/cm<sup>3</sup>

Note that the density is normally set to 1 (or 1.06), to account for actual brain density rather than the density of the simulation liquid. The power flow density is calculated assuming the excitation field to be a free space field.

### 6.6. Position of the wireless device in relation to the phantom

#### Handset Reference Points

$$P_{pwe} = E_{tot}^2 / 3770 \text{ or } P_{pwe} = H_{tot}^2 \cdot 37.7$$

- With P<sub>pwe</sub> = equivalent power density of a plane wave in mW/cm<sup>2</sup>
- E<sub>tot</sub> = total electric field strength in V/m
- H<sub>tot</sub> = total magnetic field strength in A/m

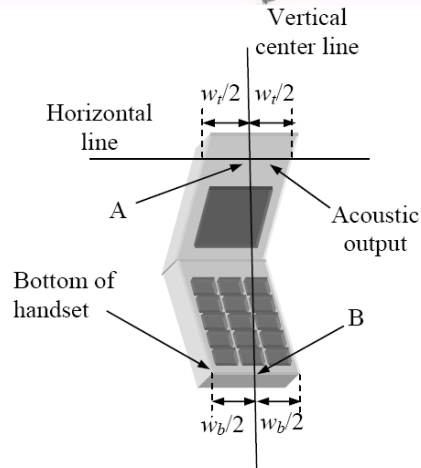
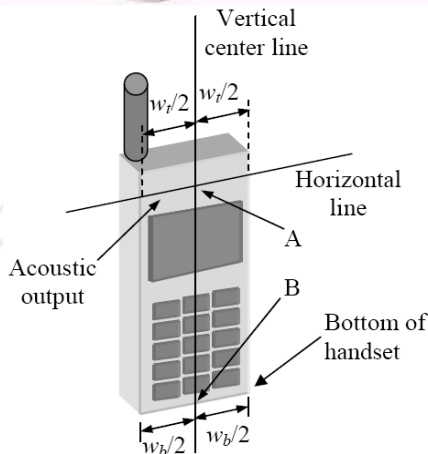

- W<sub>t</sub> Width of the handset at the level of the acoustic
- W<sub>b</sub> Width of the bottom of the handset
- A Midpoint of the width w<sub>t</sub> of the handset at the level of the acoustic output
- B Midpoint of the width w<sub>b</sub> of the bottom of the handset

#### Positioning for Cheek / Touch



**Positioning for Ear / 15° Tilt**

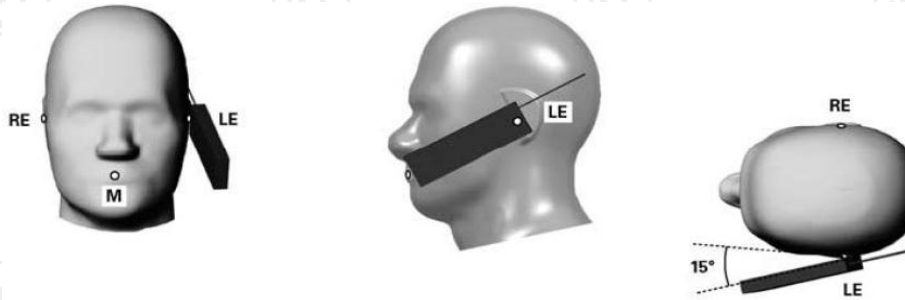

**Body Worn Accessory Configurations**

To position the device parallel to the phantom surface with either keypad up or down.

To adjust the device parallel to the flat phantom.

To adjust the distance between the device surface and the flat phantom to 15mm or holster surface and the flat phantom to 0 mm.

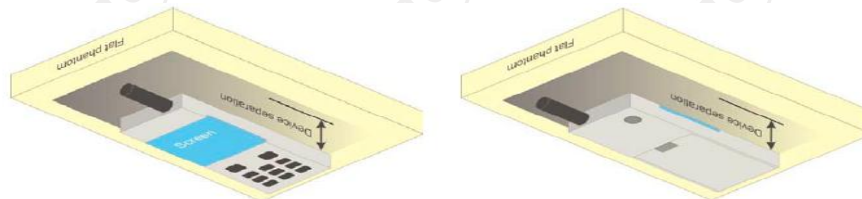

**Illustration for Body Worn Position**

**Wireless Router ( Hotspot ) Configurations**

Some battery-operated handsets have the capability to transmit and receive internet connectivity through simultaneous transmission of WIFI in conjunction with a separate licensed transmitter. The FCC has provided guidance in KDB Publication 941225 D06 where SAR test considerations for handsets (L x W ≥

9 cm x 5 cm) are based on a composite test separation distance of 10 mm from the front, back and edges of the device with antennas 2.5 cm or closer to the edge of the device, determined from general mixed use conditions for this type of devices. Since the hotspot SAR results may overlap with the body-worn accessory SAR requirements, the more conservative configurations can be considered, thus excluding some body-worn accessory SAR tests.

When the user enables the personal wireless router functions for the handset, actual operations include simultaneous transmission of both the WIFI transmitter and another licensed transmitter. Both transmitters often do not transmit at the same transmitting frequency and thus cannot be evaluated for SAR under actual use conditions. Therefore, SAR must be evaluated for each frequency transmission and mode separately and summed with the WIFI transmitter according to KDB 648474 publication procedures. The "Portable Hotspot" feature on the handset was NOT activated, to ensure the SAR measurements were evaluated for a single transmission frequency RF signal.

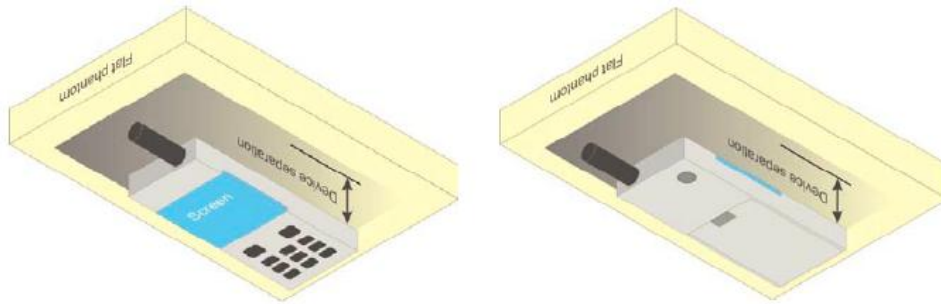
**Illustration for Hotspot Position****Limb-worn device**

A limb-worn device is a unit whose intended use includes being strapped to the arm or leg of the user while transmitting (except in idle mode). It is similar to a body-worn device. Therefore, the test positions of 6.1.4.4 also apply. The strap shall be opened so that it is divided into two parts as shown in Figure 9. The device shall be positioned directly against the phantom surface with the strap straightened as much as possible and the back of the device towards the phantom.

If the strap cannot normally be opened to allow placing in direct contact with the phantom surface, it may be necessary to break the strap of the device but ensuring to not damage the antenna.

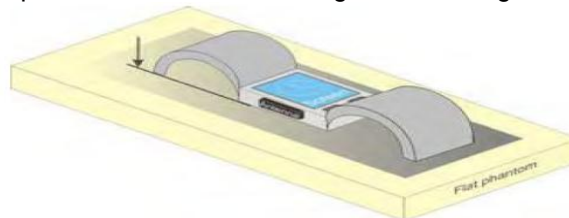
**Test position for limb-worn devices**

## 6.7. Tissue Dielectric Parameters

The liquid used for the frequency range of 100MHz-6G consisted of water, sugar, salt and Cellulose. The liquid has been previously proven to be suited for worst-case. The following Table shows the detail solution. It's satisfying the latest tissue dielectric parameters requirements proposed by the IEEE 1528 and IEC 62209.

The simulating liquids should be checked at the beginning of a series of SAR measurements to determine of the determine of the dielectric parameter are within the tolerances of the specified target values. The measured conductivity and relative permittivity should be within  $\pm 5\%$  of the target values.

The following materials are used for producing the tissue-equivalent materials

Targets for tissue simulating liquid

Frequency (MHz)	Liquid Type	Liquid Type ( $\sigma$ )	$\pm 5\%$ Range	Permittivity ( $\epsilon$ )	$\pm 5\%$ Range
300	Head	0.87	0.83~0.91	45.3	43.04~47.57
450	Head	0.87	0.83~0.91	43.5	41.33~45.68
835	Head	0.90	0.86~0.95	41.5	39.43~43.58
900	Head	0.97	0.92~1.02	41.5	39.43~43.58
1800-2000	Head	1.40	1.33~1.47	40.0	38.00~42.00
2450	Head	1.80	1.71~1.89	39.2	37.24~41.16
2600	Head	1.96	1.86~2.06	39.0	37.05~40.95
3000	Head	2.40	2.28~2.52	38.5	36.58~40.43
5800	Head	5.27	5.01~5.53	35.3	33.54~37.07
300	Body	0.92	0.87~0.97	58.2	55.29~61.11
450	Body	0.94	0.89~0.99	56.7	53.87~59.54
835	Body	0.97	0.92~1.02	55.2	52.44~57.96
900	Body	1.05	1.00~1.10	55.0	52.25~57.75
1800-2000	Body	1.52	1.44~1.60	53.3	50.64~55.97
2450	Body	1.95	1.85~2.05	52.7	50.07~55.34
2600	Body	2.16	2.05~2.27	52.5	49.88~55.13
3000	Body	2.73	2.60~2.87	52.0	49.40~54.60
5800	Body	6.00	5.70~6.30	48.2	45.79~50.61

( $\epsilon_r$  = relative permittivity,  $\sigma$  = conductivity and  $\rho = 1000 \text{ kg/m}^3$ )



### 6.8. Tissue-equivalent Liquid Properties

Test Date dd/mm/yy	Temp °C	Tissue Type	Measured Frequency ( MHz )	$\epsilon_r$	$\sigma$ (s/m)	Dev $\epsilon_r$ (%)	Dev $\sigma$ (%)
11/26/2021	22°C	750B	750	55.50	0.96	1.62	-4.16
11/29/2021	22°C	835B	825	55.26	0.93	0.11	-4.12
			835	55.24	0.94	0.07	-3.09
			850	55.21	0.97	0.02	0.00
12/01/2021	22°C	1800B	1710	53.34	1.49	0.08	-1.97
			1720	53.32	1.50	0.04	-1.32
			1750	53.31	1.51	0.02	-0.66
			1800	53.29	1.53	-0.02	0.66
12/07/2021	22°C	1900B	1850	53.34	1.49	0.08	-1.97
			1880	53.32	1.50	0.04	-1.32
			1900	53.31	1.51	0.02	-0.66
			1910	53.29	1.53	-0.02	0.66
12/13/2021	22°C	2450B	2410	54.65	1.97	3.70	1.03
			2435	54.63	1.98	3.66	1.54
			2450	54.62	2.01	3.64	3.08
			2460	54.59	2.03	3.59	4.10
12/14/2021	22°C	5200B	5200	49.02	5.46	1.70	-4.21
12/17/2021	22°C	5800B	5800	47.81	6.12	-0.81	2.00

### 6.9. System Check

The SAR system must be validated against its performance specifications before it is deployed. When SAR probe and system component or software are changed, upgraded or recalibrated, these must be validated with the SAR system(s) that operates with such component. Reference dipoles are used with the required tissue-equivalent media for system validation.

System check results have to be equal or near the values determined during dipole calibration with the relevant liquids and test system ( $\pm 10\%$ ).

System check is performed regularly on all frequency bands where tests are performed with the OPENSAR system.

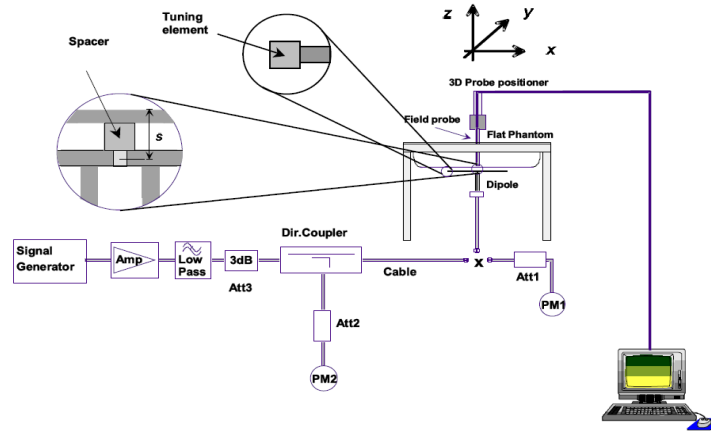

**System Check Set-up**

#### Verification Results

Frequency (MHz)	Liquid Type	Measured Value in 100mW (W/kg)		Normalized to 1W (W/kg)		Target Value (W/kg)		Deviation (%)	
		1 g Average	10 g Average	1 g Average	10 g Average	1 g Average	10 g Average	1 g Average	10 g Average
750	Body	0.83	0.56	8.30	5.60	8.46	5.81	-1.89	-3.61
835	Body	0.95	0.63	9.50	6.30	9.62	6.44	-1.25	-2.17
1800	Body	3.78	2.05	37.79	20.46	37.69	20.57	0.27	-0.54
1900	Body	3.77	1.99	37.70	19.90	38.71	20.53	-2.61	-3.07
2450	Body	5.07	2.42	50.70	24.16	50.63	23.40	0.14	3.25
5200	Body	16.35	5.62	163.50	56.20	158.49	55.40	3.16	1.44
5800	Body	18.37	6.38	183.70	63.80	183.06	61.62	0.35	3.53

Comparing to the original SAR value provided by MVG, the verification data should be within its specification of 10%. Below table shows the target SAR and measured SAR after normalized to 1W input power. The table as below indicates the system performance check can meet the variation criterion and the plots can be referred to Section 10 of this report.

## 7. Measurement Procedure

### Conducted power measurement

For WWAN power measurement, use base station simulator to configure EUT WWAN transition in conducted connection with RF cable, at maximum power in each supported wireless interface and frequency band.

Read the WWAN RF power level from the base station simulator.

For WLAN/BT power measurement, use engineering software to configure EUT WLAN/BT continuously transmission, at maximum RF power in each supported wireless interface and frequency band.

Connect EUT RF port through RF cable to the power meter or spectrum analyser, and measure WLAN/BT output power.

### Conducted power measurement

Use base station simulator to configure EUT WWAN transmission in radiated connection, and engineering software to configure EUT WLAN/BT continuously transmission, at maximum RF power, in the highest power channel.

Place the EUT in positions as Appendix B demonstrates.

Set scan area, grid size and other setting on the MVG software.

Measure SAR results for the highest power channel on each testing position.

Find out the largest SAR result on these testing positions of each band.

Measure SAR results for other channels in worst SAR testing position if the Reported SAR or highest power channel is larger than 0.8 W/kg.

According to the test standard, the recommended procedure for assessing the peak spatial-average SAR value consists of the following steps:

Power reference measurement

Area scan

Zoom scan

Power drift measurement

### Spatial Peak SAR Evaluation

The procedure for spatial peak SAR evaluation has been implemented according to the test standard. It can be conducted for 1g and 10g, as well as for user-specific masses. The MVG software includes all numerical procedures necessary to evaluate the spatial peak SAR value.

The base for the evaluation is a "cube" measurement. The measured volume must include the 1g and 10g cubes with the highest averaged SAR values. For that purpose, the center of the measured volume is aligned to the interpolated peak SAR value of a previously performed area scan.

The entire evaluation of the spatial peak values is performed within the post-processing engine (SEMCAD). The system always gives the maximum values for 1g and 10g cubes. The algorithm to find the cube with highest averaged SAR is divided into the following stages:

Extraction of the measured data (grid and values) from the Zoom Scan.

Calculation of the SAR value at every measurement point based on all stored data (A/D values and measurement parameters).

Generation of a high-resolution mesh within the measured volume.

Interpolation of all measured values from the measurement grid to the high-resolution grid

Extrapolation of the entire 3-D field distribution to the phantom surface over the distance from sensor to surface

Calculation of the averaged SAR within masses of 1g and 10g.

### Power Reference Measurement

The Power Reference Measurement and Power Drift Measurement are for monitoring the power drift of the device under test in the batch process. The minimum distance of probe sensors to surface determines the closest measurement point to phantom surface. This distance cannot be smaller than the distance of sensor calibration points to probe tip as defined in the probe properties

### Area & Zoom Scan Procedures

First Area Scan is used to locate the approximate location(s) of the local peak SAR value(s). The measurement grid within an Area Scan is defined by the grid extent, grid step size and grid offset. Next, in order to determine the EM field distribution in a three-dimensional spatial extension, Zoom Scan is required. The Zoom Scan is performed around the highest E-field value to determine the averaged SAR-distribution over 10g. Area scan and zoom scan resolution setting follows KDB 865664 D01v01r03 quoted below.

		≤ 3 GHz	> 3 GHz	
Maximum distance from closest measurement point (geometric center of probe sensors) to phantom surface		5 mm ± 1 mm	$\frac{1}{2} \cdot \delta \cdot \ln(2)$ mm ± 0.5 mm	
Maximum probe angle from probe axis to phantom surface normal at the measurement location		30° ± 1°	20° ± 1°	
Maximum area scan spatial resolution: $\Delta x_{Area}, \Delta y_{Area}$		≤ 2 GHz: ≤ 15 mm 2 – 3 GHz: ≤ 12 mm	3 – 4 GHz: ≤ 12 mm 4 – 6 GHz: ≤ 10 mm	
		When the x or y dimension of the test device, in the measurement plane orientation, is smaller than the above, the measurement resolution must be ≤ the corresponding x or y dimension of the test device with at least one measurement point on the test device.		
Maximum zoom scan spatial resolution: $\Delta x_{Zoom}, \Delta y_{Zoom}$		≤ 2 GHz: ≤ 8 mm 2 – 3 GHz: ≤ 5 mm*	3 – 4 GHz: ≤ 5 mm* 4 – 6 GHz: ≤ 4 mm*	
Maximum zoom scan spatial resolution, normal to phantom surface	uniform grid: $\Delta z_{Zoom}(n)$	≤ 5 mm	3 – 4 GHz: ≤ 4 mm 4 – 5 GHz: ≤ 3 mm 5 – 6 GHz: ≤ 2 mm	
	graded grid	$\Delta z_{Zoom}(1)$ : between 1 <sup>st</sup> two points closest to phantom surface	≤ 4 mm	3 – 4 GHz: ≤ 3 mm 4 – 5 GHz: ≤ 2.5 mm 5 – 6 GHz: ≤ 2 mm
		$\Delta z_{Zoom}(n>1)$ : between subsequent points	≤ 1.5 · $\Delta z_{Zoom}(n-1)$ mm	
Minimum zoom scan volume	x, y, z	≥ 30 mm	3 – 4 GHz: ≥ 28 mm 4 – 5 GHz: ≥ 25 mm 5 – 6 GHz: ≥ 22 mm	
Note: $\delta$ is the penetration depth of a plane-wave at normal incidence to the tissue medium; see IEEE Std 1528-2013 for details.				
* When zoom scan is required and the <i>reported</i> SAR from the <i>area scan based 1-g SAR estimation</i> procedures of KDB Publication 447498 is ≤ 1.4 W/kg, ≤ 8 mm, ≤ 7 mm and ≤ 5 mm zoom scan resolution may be applied, respectively, for 2 GHz to 3 GHz, 3 GHz to 4 GHz and 4 GHz to 6 GHz.				

### Volume Scan Procedures

The volume scan is used for assess overlapping SAR distributions for antennas transmitting in different frequency bands. It is equivalent to an oversized zoom scan used in standalone measurements. The measurement volume will be used to enclose all the simultaneous transmitting antennas. For antennas transmitting simultaneously in different frequency bands, the volume scan is measured separately in each frequency band. In order to sum correctly to compute the 1g aggregate SAR, the EUT remain in the same test position for all measurements and all volume scan use the same spatial resolution and grid spacing. When all volume scan were completed, the software, SEMCAD post-processor scan combine and subsequently superpose these measurement data to calculating the multiband SAR.

**SAR Averaged Methods**

In MVG, the interpolation and extrapolation are both based on the modified Quadratic Shepard's method. The interpolation scheme combines a least-square fitted function method and a weighted average method which are the two basic types of computational interpolation and approximation.

Extrapolation routines are used to obtain SAR values between the lowest measurement points and the inner phantom surface. The extrapolation distance is determined by the surface detection distance and the probe sensor offset. The uncertainty increases with the extrapolation distance. To keep the uncertainty within 1% for the 1g and 10g cubes, the extrapolation distance should not be larger than 5 mm.

**Power Drift Monitoring**

All SAR testing is under the EUT install full charged battery and transmit maximum output power. In MVG measurement software, the power reference measurement and power drift measurement procedures are used for monitoring the power drift of EUT during SAR test. Both these procedures measure the field at a specified reference position before and after the SAR testing. The software will calculate the field difference in dB. If the power drifts more than 5%, the SAR will be retested.

**Power Drift measurement**

The drift job measures the field at the same location as the most recent reference job within the same procedure, and with the same settings. The drift measurement gives the field difference in dB from the reading conducted within the last reference measurement. Several drift measurements are possible for

**Measurement Uncertainty**

Per KDB 865664 D01 SAR Measurement 100KHz to 6GHz ,when the highest measurement 1-g SAR within a frequency band is <1.5W/kg, the extensive SAR measurement uncertainty analysis described IEEE Std 1528-2013 is not required in SAR report submitted for equipment approval.

## 8. Conducted Output Power

Band: GSM 850	Measured Power (dBm)			Calculation (dB)	Averaged Power (dBm)		
	Channel	128	190		251	128	190
Frequency	824.2	836.6	848.8		824.2	836.6	848.8
GSM (GMSK, Voice)	32.89	32.95	33.01	-9.03	23.86	23.92	<b>23.98</b>
GPRS (GMSK, 1-slot)	32.96	32.99	33.05	-9.03	23.93	23.96	24.02
GPRS (GMSK, 2-slot)	32.33	32.38	32.45	-6.02	26.31	26.36	26.43
GPRS (GMSK, 3-slot)	30.37	30.74	30.82	-4.26	26.11	26.48	26.56
GPRS (GMSK, 4-slot)	29.50	29.58	29.67	-3.01	26.49	26.57	<b>26.66</b>
EGPRS (1-slot)	28.46	28.34	28.08	-9.03	19.43	19.31	19.05
EGPRS (2-slot)	27.21	27.21	26.94	-6.02	21.19	21.19	20.92
EGPRS (3-slot)	25.04	25.05	24.79	-4.26	20.78	20.79	20.53
EGPRS (4-slot)	23.80	23.75	23.57	-3.01	20.79	20.74	20.56

Note:

- Division Factors  
To average the power, the division factor is as follows:  
1TX-slot = 1 transmit time slot out of 8 time slots=> conducted power divided by (8/1) => -9.03dB  
2TX-slots = 2 transmit time slots out of 8 time slots=> conducted power divided by (8/2) => -6.02dB  
3TX-slots = 3 transmit time slots out of 8 time slots=> conducted power divided by (8/3) => -4.26dB  
4TX-slots = 4 transmit time slots out of 8 time slots=> conducted power divided by (8/4) => -3.01dB
- According to the conducted power as above, the body measurements are performed with 4Tx slots for 850MHz for GPRS.
- The device do not support power reduction, so power of hotspot activated as the same as hotspot disabled

Band: GSM 1900	Measured Power (dBm)			Calculation (dB)	Averaged Power (dBm)		
	Channel	512	661		810	512	661
Frequency	1850.2	1880.0	1909.8		1850.2	1880.0	1909.8
GSM (GMSK, Voice)	30.46	30.40	30.43	-9.03	<b>21.43</b>	21.37	21.40
GPRS (GMSK, 1-slot)	30.47	30.42	30.44	-9.03	21.44	21.39	21.41
GPRS (GMSK, 2-slot)	29.74	29.72	29.76	-6.02	23.72	23.70	23.74
GPRS (GMSK, 3-slot)	28.03	28.03	28.09	-4.26	23.77	23.77	23.83
GPRS (GMSK, 4-slot)	26.84	26.95	27.04	-3.01	23.83	23.94	<b>24.03</b>
EGPRS (1-slot)	29.01	28.83	28.85	-9.03	19.98	19.80	19.82
EGPRS (2-slot)	27.84	27.85	27.88	-6.02	21.82	21.83	21.86
EGPRS (3-slot)	26.04	25.87	25.89	-4.26	21.78	21.61	21.63
EGPRS (4-slot)	24.74	24.56	24.58	-3.01	21.73	21.55	21.57

Note:

- Division Factors

To average the power, the division factor is as follows:

1TX-slot = 1 transmit time slot out of 8 time slots=> conducted power divided by (8/1) => -9.03dB

2TX-slots = 2 transmit time slots out of 8 time slots=> conducted power divided by (8/2) => -6.02dB

3TX-slots = 3 transmit time slots out of 8 time slots=> conducted power divided by (8/3) => -4.26dB

4TX-slots = 4 transmit time slots out of 8 time slots=> conducted power divided by (8/4) => -3.01dB
- According to the conducted power as above, the body measurements are performed with 4Tx slots for 1900MHz for GPRS.
- The device do not support power reduction, so power of hotspot activated as the same as hotspot disabled

Band	WCDMA Band II			WCDMA Band V		
Channel	9262	9400	9538	4132	4182	4233
Frequency	1852.40	1880.00	1907.60	826.40	836.40	846.60
RMC 12.2Kbps	23.17	23.20	<b>23.22</b>	22.91	<b>22.98</b>	22.86
HSDPA Subtest-1	22.21	22.19	22.21	21.97	22.06	22.07
HSDPA Subtest-2	21.79	21.79	21.75	21.50	21.65	21.64
HSDPA Subtest-3	21.69	21.67	21.70	21.44	21.54	21.55
HSDPA Subtest-4	21.65	21.64	21.67	21.42	21.49	21.50
HSUPA Subtest-1	20.18	20.15	20.18	19.99	20.05	20.02
HSUPA Subtest-2	20.68	20.67	20.66	20.45	20.53	20.51
HSUPA Subtest-3	21.19	21.18	21.15	20.95	21.05	21.02
HSUPA Subtest-4	20.20	20.18	20.19	20.02	20.12	20.06
HSUPA Subtest-5	22.17	22.15	20.42	22.01	22.04	22.02
Band	WCDMA Band IV					
Channel	1312	1413	1513			
Frequency	1712.4	1732.6	1752.6			
RMC 12.2Kbps	23.11	23.07	<b>23.12</b>			
HSDPA Subtest-1	21.99	22.04	21.92			
HSDPA Subtest-2	21.53	21.65	21.45			
HSDPA Subtest-3	21.44	21.50	21.38			
HSDPA Subtest-4	21.45	21.51	21.38			
HSUPA Subtest-1	19.93	20.01	19.86			
HSUPA Subtest-2	20.40	20.47	20.36			
HSUPA Subtest-3	20.89	20.94	20.84			
HSUPA Subtest-4	19.94	20.00	19.86			
HSUPA Subtest-5	21.93	22.02	21.88			

Note:

1. According to the power listed above, the HSDPA and HSUPA were not determined for SAR testing.
2. The default test configuration is to measure SAR with an established radio link between the EUT and a communication test set using a 12.2kbps RMC(reference measurement channel) configuration in test loop mode
3. The device do not support power reduction, so power of hotspot activated as the same as hotspot disabled



WLAN 2.4G						
Mode	802.11b			802.11g		
Channel	1	6	11	1	6	11
Frequency	2412	2437	2462	2412	2437	2462
Average Power (dBm)	17.67	17.19	16.99	17.55	17.36	17.47
Mode	802.11n(HT20)			802.11n(HT40)		
Channel	1	6	11	3	6	9
Frequency	2412	2437	2462	2422	2437	2452
Average Power (dBm)	17.64	17.54	17.23	<b>17.95</b>	17.37	17.64

**Note**

1. Per KDB 248227 D01 v02r02, choose the highest output power channel to test SAR and determine further SAR exclusion.
2. The output power of all data rate were prescan , just the worst case (the lowest data rate) of all mode were shown in report

WLAN 5.2G						
Mode	IEEE 802.11a			IEEE 802.11n HT20		
Channel	36	40	48	36	40	48
Frequency	5180	5200	5240	5180	5200	5240
Average Power (dBm)	16.52	16.24	16.18	16.53	16.20	16.14
Mode	IEEE 802.11n HT40		IEEE 802.11ac HT20			
Channel	38		46		36	40
Frequency	5190		5230		5180	5240
Average Power (dBm)	16.37		16.10		<b>16.59</b>	16.23
Mode	IEEE 802.11ac HT40		IEEE 802.11ac HT80			
Channel	38		46		42	
Frequency	5190		5230		5210	
Average Power (dBm)	16.40		16.04		16.12	
WLAN 5.8G						
Mode	IEEE 802.11a			IEEE 802.11n HT20		
Channel	149	157	165	149	157	165
Frequency	5745	5785	5825	5745	5785	5825
Average Power (dBm)	16.02	15.84	16.38	16.33	15.92	<b>16.59</b>
Mode	IEEE 802.11n HT40		IEEE 802.11ac HT20			
Channel	151		159		149	157
Frequency	5755		5795		5745	5825
Average Power (dBm)	16.03		15.83		16.04	15.80
Mode	IEEE 802.11ac HT40		IEEE 802.11ac HT80			
Channel	151		159		155	
Frequency	5755		5795		5775	
Average Power (dBm)	16.14		15.84		15.87	

Bluetooth						
Mode	GFSK			Pi/4DQPSK		
Channel	0	39	78	0	39	78
Frequency	2402	2441	2480	2402	2441	2480
Average Power (dBm)	<b>4.64</b>	3.1	4.11	3.57	2.35	3.3
Mode	8DPSK			BLE		
Channel	0	39	78	0	20	39
Frequency	2402	2441	2480	2402	2440	2480
Average Power (dBm)	3.61	2.24	3.13	-2.04	-3.11	-2.55

Channel	Frequency (GHz)	Max. Tune-up Power (dBm)	Max. Power (mW)	Test distance (mm)	Result	Exclusion thresholds for 1-g SAR	Exclusion thresholds for 10-g SAR
0	2.402	5.00	3.16	5	0.98	3.0	7.5

**Note**

- Per KDB 447498 D01v06, the 1-g SAR test exclusion thresholds for 100 MHz to 6 GHz at test separation distances  $\leq 50$  mm are determined by:  

$$\left[ \frac{\text{max. power of channel, including tune-up tolerance, mW}}{\text{min. test separation distance, mm}} \right] \cdot [\sqrt{f(\text{GHz})}] \leq 3.0$$
 for 1-g SAR, where  
 ·f(GHz) is the RF channel transmit frequency in GHz  
 ·Power and distance are rounded to the nearest mW and mm before calculation  
 ·The result is rounded to one decimal place for comparison
- Base on the result of note1, RF exposure evaluation of BLE is not required.
- Per KDB 248227 D01 v02r02, choose the highest output power channel to test SAR and determine further SAR exclusion.
- The output power of all data rate were prescan, just the worst case (the lowest data rate) of all mode were shown in report.

LTE Band 2

Conducted Power of LTE Band 2								
Bandwidth	Modulation	RB size	RB offset	Channel	Channel	Channel		
				18607	18900	19193		
1.4MHz	QPSK	1	0.00	22.78	22.79	22.72		
			2.00	22.87	23.02	22.83		
			5.00	22.76	22.79	22.73		
		3	0.00	22.89	22.84	22.81		
			1.00	22.88	22.83	22.75		
			3.00	22.92	22.89	22.82		
	6	0.00	21.80	21.75	21.72			
	16QAM	1	0.00	21.67	21.61	21.53		
			2.00	21.89	21.63	21.64		
			5.00	21.69	21.59	21.53		
		3	0.00	21.68	21.67	21.62		
			1.00	21.70	21.67	21.60		
			3.00	21.72	21.69	21.59		
		6	0.00	20.85	20.62	20.59		
		Bandwidth	Modulation	RB size	RB offset	Channel	Channel	Channel
3MHz		QPSK	1	0.00	22.87	22.79	22.73	
	8.00			22.86	22.86	22.79		
	14.00			22.88	22.75	22.76		
	8		0.00	21.86	21.83	21.78		
			4.00	21.89	21.82	21.79		
			7.00	21.85	21.82	21.75		
	15		0.00	21.86	21.77	21.73		
	16QAM		1	0.00	21.77	21.58	21.77	
				8.00	21.73	21.60	21.82	
		14.00		21.69	21.61	21.73		
		8	0.00	20.86	20.86	20.79		
			4.00	20.91	20.85	20.79		
			7.00	20.90	20.87	20.78		
		15	0.00	20.77	20.69	20.79		
		Bandwidth	Modulation	RB size	RB offset	Channel	Channel	Channel
		3MHz	QPSK	1	0.00	22.87	22.79	22.73
	8.00				22.86	22.86	22.79	
	14.00				22.88	22.75	22.76	
8	0.00			21.86	21.83	21.78		
	4.00			21.89	21.82	21.79		
	7.00			21.85	21.82	21.75		
15	0.00			21.86	21.77	21.73		
16QAM	1			0.00	21.77	21.58	21.77	
				8.00	21.73	21.60	21.82	
			14.00	21.69	21.61	21.73		
	8		0.00	20.86	20.86	20.79		
			4.00	20.91	20.85	20.79		
			7.00	20.90	20.87	20.78		
	15		0.00	20.77	20.69	20.79		

**Conducted Power of LTE Band 2**

Bandwidth	Modulation	RB size	RB offset	Channel	Channel	Channel		
				18625	18900	19175		
5MHz	QPSK	1	0.00	22.77	22.71	22.63		
			12.00	22.87	22.83	22.82		
			24.00	22.67	22.68	22.66		
		12	0.00	21.85	21.76	21.75		
			6.00	21.86	21.75	21.71		
			13.00	21.84	21.76	21.67		
		25	0.00	21.85	21.79	21.69		
			16QAM	1	0.00	21.84	21.57	21.58
					12.00	21.97	21.70	21.66
	24.00	21.80			21.57	21.60		
	12	0.00		20.92	20.80	20.74		
		6.00		20.91	20.83	20.77		
		13.00		20.88	20.80	20.62		
	25	0.00	20.86	20.85	20.73			
		Bandwidth	Modulation	RB size	RB offset	Channel	Channel	Channel
					18650	18900	19150	
10MHz	QPSK	1	0.00	22.83	22.67	22.66		
			24.00	22.87	22.92	22.79		
			49.00	22.71	22.75	22.61		
		25	0.00	21.77	21.79	21.76		
			12.00	21.79	21.83	21.71		
			25.00	21.83	21.72	21.58		
		50	0.00	21.75	21.69	21.68		
			16QAM	1	0.00	21.65	21.51	21.66
					24.00	21.72	21.63	21.69
	49.00	21.54			21.47	21.68		
	25	0.00		20.82	20.83	20.74		
		24.00		20.87	20.84	20.81		
		49.00		20.85	20.81	20.59		
	50	0.00		20.84	20.77	20.70		

**Conducted Power of LTE Band 2**

Bandwidth	Modulation	RB size	RB offset	Channel	Channel	Channel		
				18675	18900	19125		
15MHz	QPSK	1	0.00	22.60	22.61	22.56		
			38.00	22.62	22.74	22.59		
			74.00	22.50	22.60	22.50		
		37	0.00	21.72	21.41	21.59		
			18.00	21.77	21.50	21.60		
			37.00	21.58	21.29	21.52		
			75	0.00	21.75	21.74	21.66	
			16QAM	1	0.00	21.74	21.37	21.56
					38.00	21.82	21.48	21.61
	74.00	21.64			21.32	21.54		
	37	0.00		21.69	21.38	21.56		
		18.00		21.77	21.49	21.60		
		37.00		21.66	21.31	21.50		
	75	0.00	20.79	20.72	20.63			
	Bandwidth	Modulation	RB size	RB offset	Channel	Channel	Channel	
					18700	18900	19100	
	20MHz	QPSK	1	0.00	22.55	22.50	22.49	
				49.00	<b>22.88</b>	22.78	22.82	
99.00				22.47	22.40	22.43		
50			0.00	<b>21.64</b>	21.70	21.62		
			25.00	21.60	21.72	21.62		
			50.00	21.65	21.66	21.45		
			100	0.00	21.60	21.69	21.49	
			16QAM	1	0.00	21.70	21.28	21.36
					49.00	21.96	21.63	21.67
99.00		21.60			21.23	21.37		
50		0.00		20.69	20.82	20.66		
		25.00		20.65	20.80	20.66		
		50.00		20.70	20.77	20.48		
		100		0.00	20.64	20.78	20.55	

LTE Band 4

Conducted Power of LTE Band 4							
Bandwidth	Modulation	RB size	RB offset	Channel	Channel	Channel	
				19957	20175	20393	
1.4MHz	QPSK	1	0.00	22.61	22.68	22.56	
			2.00	22.74	22.75	22.61	
			5.00	22.58	22.64	22.57	
		3	0.00	22.67	22.73	22.65	
			1.00	22.69	22.73	22.66	
			3.00	22.69	22.74	22.67	
	6	0.00	21.61	21.64	21.56		
	16QAM	1	0.00	21.42	21.44	21.37	
			2.00	21.58	21.68	21.49	
			5.00	21.42	21.50	21.38	
		3	0.00	21.54	21.59	21.49	
			1.00	21.53	21.61	21.49	
			3.00	21.54	21.61	21.47	
		6	0.00	20.47	20.56	20.46	
		Bandwidth	Modulation	RB size	RB offset	Channel	Channel
19965						20175	20385
3MHz	QPSK	1	0.00	22.58	22.60	22.47	
			8.00	22.55	22.50	22.22	
			14.00	22.56	22.53	21.94	
		8	0.00	21.47	21.63	21.11	
			4.00	21.50	21.64	21.21	
			7.00	21.50	21.61	21.35	
	15	0.00	21.49	21.60	21.00		
	16QAM	1	0.00	21.45	21.39	21.52	
			8.00	21.45	21.39	21.27	
			14.00	21.36	21.39	21.26	
		8	0.00	20.55	20.63	20.16	
			4.00	20.56	20.66	20.20	
			7.00	20.56	20.63	20.04	
		15	0.00	20.52	20.53	20.01	

**Conducted Power of LTE Band 4**

Bandwidth	Modulation	RB size	RB offset	Channel	Channel	Channel			
				19975	20175	20375			
5MHz	QPSK	1	0.00	22.48	22.54	22.47			
			12.00	22.55	22.38	22.25			
			24.00	22.40	22.21	21.96			
		12	0.00	21.58	21.50	21.07			
			6.00	21.62	21.47	21.06			
			13.00	21.46	21.66	21.06			
	25	0.00	21.39	21.64	21.21				
		16QAM	1	0.00	21.57	21.11	21.14		
				12.00	21.72	21.15	21.20		
	24.00			21.35	21.16	20.94			
	12	12	0.00	20.64	20.20	20.02			
			6.00	20.56	20.43	20.08			
			13.00	20.29	20.67	20.06			
	25	25	0.00	20.49	20.64	20.11			
			Bandwidth	Modulation	RB size	RB offset	Channel	Channel	Channel
20000							20175	20350	
10MHz	QPSK	1	0.00	22.55	22.60	22.45			
			24.00	22.67	22.78	22.65			
			49.00	22.57	22.56	22.38			
		25	25	0.00	21.59	21.71	21.63		
				12.00	21.68	21.74	21.63		
				25.00	21.69	21.67	21.56		
		50	50	0.00	21.57	21.68	21.56		
				16QAM	1	0.00	21.46	21.39	21.55
						24.00	21.52	21.53	21.75
	49.00	21.41	21.38			21.48			
	25	25	0.00	20.70	20.76	20.65			
			12.00	20.70	20.78	20.70			
			25.00	20.71	20.75	20.56			
	50	50	0.00	20.66	20.68	20.59			



**Conducted Power of LTE Band 4**

Bandwidth	Modulation	RB size	RB offset	Channel	Channel	Channel	
				20025	20175	20325	
15MHz	QPSK	1	0.00	22.29	22.48	22.38	
			38.00	22.41	22.54	22.42	
			74.00	22.34	22.40	22.36	
		37	0.00	21.56	21.27	21.44	
			18.00	21.57	21.35	21.52	
			37.00	21.52	21.19	21.38	
	75	0.00	21.53	21.58	21.54		
	16QAM	1	0.00	21.49	21.26	21.43	
			38.00	21.60	21.37	21.49	
			74.00	21.56	21.18	21.41	
		37	0.00	21.55	21.30	21.45	
			18.00	21.59	21.37	21.48	
			37.00	21.52	21.26	21.41	
	75	0.00	20.61	20.59	20.51		
Bandwidth	Modulation	RB size	RB offset	Channel	Channel	Channel	
20MHz	QPSK	1	0.00	22.24	22.31	22.31	
			49.00	22.65	22.58	<b>22.67</b>	
			99.00	22.33	22.30	22.29	
		50	0.00	21.47	21.59	21.62	
			25.00	21.49	21.59	<b>21.67</b>	
			50.00	21.60	21.55	21.41	
		100	0.00	21.54	21.56	21.48	
		16QAM	1	0.00	21.43	21.17	21.23
				49.00	21.84	21.47	21.59
	99.00			21.55	21.14	21.20	
	50		0.00	20.53	20.67	20.65	
			25.00	20.49	20.64	20.65	
			50.00	20.71	20.64	20.40	
	100		0.00	20.59	20.51	20.55	

**LTE Band 5**

Conducted Power of LTE Band 5							
Bandwidth	Modulation	RB size	RB offset	Channel	Channel	Channel	
				20407	20525	20643	
1.4MHz	QPSK	1	0.00	22.61	22.72	22.54	
			2.00	22.73	22.81	22.63	
			5.00	22.55	22.66	22.51	
		3	0.00	22.61	22.76	22.70	
			1.00	22.61	22.75	22.67	
			3.00	22.64	22.64	22.64	
	6	0.00	21.59	21.36	21.51		
	16QAM	1	0.00	21.45	21.49	21.43	
			2.00	21.43	21.73	21.58	
			5.00	21.39	21.51	21.39	
		3	0.00	21.46	21.57	21.48	
			1.00	21.47	21.35	21.37	
			3.00	21.48	21.47	21.46	
		6	0.00	20.45	20.33	20.46	
		Bandwidth	Modulation	RB size	RB offset	Channel	Channel
20415						20525	20635
3MHz	QPSK	1	0.00	22.70	22.71	22.60	
			8.00	22.61	22.72	22.55	
			14.00	22.59	22.68	22.57	
		8	0.00	21.56	21.74	21.58	
			4.00	21.61	21.75	21.64	
			7.00	21.61	21.75	21.55	
	15	0.00	21.57	21.74	21.61		
	16QAM	1	0.00	21.56	21.46	21.60	
			8.00	21.48	21.54	21.61	
			14.00	21.41	21.44	21.65	
		8	0.00	20.59	20.73	20.65	
			4.00	20.61	20.76	20.65	
			7.00	20.60	20.70	20.63	
		15	0.00	20.49	20.68	20.57	

**Conducted Power of LTE Band 5**

Bandwidth	Modulation	RB size	RB offset	Channel	Channel	Channel	
				20425	20525	20625	
5MHz	QPSK	1	0.00	22.53	22.60	22.55	
			12.00	22.59	22.77	22.64	
			24.00	22.50	22.60	22.59	
		12	0.00	21.49	21.66	21.65	
			6.00	21.46	21.67	21.64	
			13.00	21.62	21.67	21.45	
	25	0.00	21.55	21.71	21.53		
		16QAM	1	0.00	21.62	21.59	21.54
				12.00	21.66	21.66	21.56
	24.00			21.59	21.53	21.43	
	12	0.00	20.52	20.69	20.61		
		6.00	20.51	20.68	20.64		
		13.00	20.61	20.70	20.42		
	25	0.00	20.52	20.77	20.58		
	Bandwidth	Modulation	RB size	RB offset	Channel	Channel	Channel
				20450	20525	20600	
10MHz	QPSK	1	0.00	22.63	22.68	22.59	
			24.00	22.79	<b>22.81</b>	22.67	
			49.00	22.68	22.62	22.61	
		25	0.00	21.58	21.88	21.46	
			12.00	21.53	<b>21.89</b>	21.45	
			25.00	21.42	21.84	21.46	
		50	0.00	21.50	21.83	21.42	
		16QAM	1	0.00	21.48	21.45	21.60
				24.00	21.56	21.62	21.71
	49.00			21.53	21.40	21.60	
	25		0.00	20.59	20.97	20.42	
			12.00	20.57	20.96	20.44	
			25.00	20.46	20.89	20.47	
	50		0.00	20.54	20.83	20.40	

**LTE Band 12**

Conducted Power of LTE Band 12						
Bandwidth	Modulation	RB size	RB offset	Channel	Channel	Channel
				23017	23095	23173
1.4MHz	QPSK	1	0.00	22.52	22.48	22.42
			2.00	22.55	22.61	22.48
			5.00	22.43	22.56	22.50
		3	0.00	22.58	22.57	22.56
			1.00	22.52	22.58	22.59
			3.00	22.61	22.63	22.65
	6	0.00	21.47	21.50	21.46	
	16QAM	1	0.00	21.36	21.34	21.28
			2.00	21.43	21.48	21.46
			5.00	21.34	21.35	21.32
		3	0.00	21.44	21.45	21.38
			1.00	21.43	21.45	21.42
			3.00	21.44	21.45	21.44
	6	0.00	20.35	20.34	20.29	
	Bandwidth	Modulation	RB size	RB offset	Channel	Channel
23025					23095	23165
3MHz	QPSK	1	0.00	22.56	22.53	22.46
			8.00	22.56	22.49	22.45
			14.00	22.52	22.52	22.52
		8	0.00	21.45	21.47	21.59
			4.00	21.46	21.45	21.51
			7.00	21.54	21.50	21.48
	15	0.00	21.54	21.52	21.46	
	16QAM	1	0.00	21.49	21.29	21.56
			7.00	21.41	21.32	21.47
			14.00	21.37	21.30	21.54
		8	0.00	20.51	20.54	20.59
			4.00	20.53	20.48	20.51
			7.00	20.53	20.59	20.49
	15	0.00	20.41	20.48	20.56	

**Conducted Power of LTE Band 12**

Bandwidth	Modulation	RB size	RB offset	Channel	Channel	Channel		
				23035	23095	23155		
5MHz	QPSK	1	0.00	22.49	22.51	22.39		
			12.00	22.54	22.62	22.52		
			24.00	22.48	22.47	22.46		
		12	0.00	21.48	21.56	21.55		
			6.00	21.45	21.54	21.54		
			13.00	21.50	21.53	21.42		
	25	0.00	21.47	21.59	21.46			
	16QAM	1	0.00	21.40	21.44	21.56		
			12.00	21.46	21.54	21.58		
			24.00	21.39	21.43	21.58		
		12	0.00	20.48	20.54	20.63		
			6.00	20.49	20.58	20.64		
			13.00	20.52	20.58	20.47		
		25	0.00	20.54	20.67	20.51		
Bandwidth		Modulation	RB size	RB offset	Channel	Channel	Channel	
10MHz	QPSK	1	0.00	22.54	22.53	22.52		
			24.00	22.57	<b>22.65</b>	22.52		
			49.00	22.55	22.56	22.48		
		25	0.00	21.59	21.71	21.48		
			12.00	21.61	<b>21.75</b>	21.46		
			25.00	21.51	21.71	21.47		
		50	0.00	21.58	21.72	21.49		
		16QAM	1	0.00	21.39	21.26	21.50	
				24.00	21.56	21.40	21.67	
	49.00			21.43	21.33	21.59		
	25		0.00	20.64	20.80	20.52		
			12.00	20.63	20.81	20.51		
			25.00	20.65	20.83	20.47		
	50		0.00	20.66	20.78	20.51		
	Bandwidth		Modulation	RB size	RB offset	Channel	Channel	Channel
	10MHz		QPSK	1	0.00	22.54	22.53	22.52
		24.00			22.57	<b>22.65</b>	22.52	
		49.00			22.55	22.56	22.48	
25		0.00		21.59	21.71	21.48		
		12.00		21.61	<b>21.75</b>	21.46		
		25.00		21.51	21.71	21.47		
50		0.00		21.58	21.72	21.49		
16QAM		1		0.00	21.39	21.26	21.50	
				24.00	21.56	21.40	21.67	
			49.00	21.43	21.33	21.59		
		25	0.00	20.64	20.80	20.52		
			12.00	20.63	20.81	20.51		
			25.00	20.65	20.83	20.47		
		50	0.00	20.66	20.78	20.51		

LTE Band 17

Conducted Power of LTE Band 17

Bandwidth	Modulation	RB size	RB offset	Channel	Channel	Channel		
				23755	23790	23825		
5MHz	QPSK	1	0.00	22.38	22.50	22.48		
			12.00	22.53	22.62	22.62		
			24.00	22.39	22.44	22.44		
		12	0.00	21.58	21.46	21.51		
			6.00	21.61	21.49	21.52		
			13.00	21.54	21.57	21.47		
		25	0.00	21.60	21.57	21.44		
		16QAM	1	0.00	21.54	21.37	21.43	
				12.00	21.69	21.57	21.56	
	24.00			21.50	21.33	21.45		
	12		0.00	20.70	20.56	20.51		
			6.00	20.66	20.52	20.53		
			13.00	20.62	20.62	20.44		
	25	0.00	20.60	20.62	20.52			
	Bandwidth	Modulation	RB size	RB offset	Channel	Channel	Channel	
10MHz	QPSK	1	0.00	22.50	22.47	22.53		
			24.00	<b>22.77</b>	22.59	22.69		
			49.00	22.45	22.49	22.54		
		25	0.00	<b>21.65</b>	21.56	21.51		
			12.00	21.65	21.59	21.51		
			25.00	21.68	21.59	21.50		
		50	0.00	21.68	21.62	21.49		
		16QAM	1	0.00	21.29	21.56	21.44	
				24.00	21.50	21.64	21.54	
	49.00			21.22	21.51	21.39		
	25		0.00	20.70	20.58	20.57		
			12.00	20.73	20.58	20.56		
			25.00	20.78	20.58	20.53		
	50		0.00	20.65	20.60	20.52		
	Bandwidth		Modulation	RB size	RB offset	Channel	Channel	Channel
	10MHz		QPSK	1	0.00	23780	23790	23800
						22.50	22.47	22.53

## 9. Exposure Position Consideration

### 9.1. EUT Antenna Location

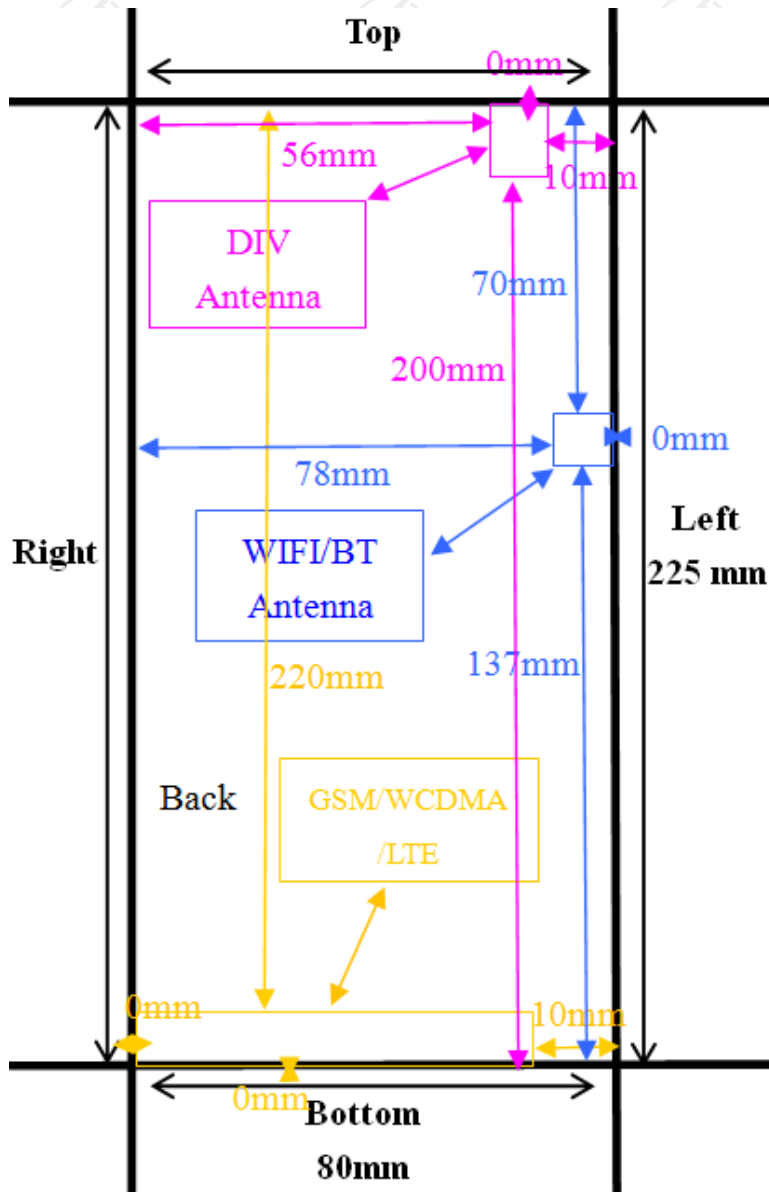

### 9.2. Test Position Consideration

Test Positions						
Mode	Back	Front	Top Side	Bottom Side	Right Side	Left Side
GSM/WCDMA/CDMA /LTE	Yes	Yes	No	Yes	Yes	Yes
WIFI/BT	Yes	Yes	No	No	No	Yes

**Note:**

- KDB 447498 D01v06, particular DUT edges were not required to be evaluated for SAR if the antenna-to-edge distance is greater than 2.5cm.

## 10. SAR Test Results Summary

### 10.1. Body-Worn 1g SAR Data

Band	Mode	Test Position with 10mm	CH.	Freq. (MHz)	Ave. Power (dBm)	Tune-Up Limit (dBm)	Power Drift (%)	Meas. SAR1g (W/kg)	Scaling Factor	Reported SAR1g (W/kg)	Limit (W/Kg)
GSM850	voice	Front	251	848.8	33.01	33.50	-1.46	0.17	1.119	0.19	1.60
		Back	251	848.8	33.01	33.50	2.40	0.32	1.119	0.36	
	GPRS 4 slots	Front	251	848.8	29.67	30.00	1.28	0.31	1.079	0.33	
		Back	251	848.8	29.67	30.00	1.84	0.62	1.079	<b>0.67</b>	
GSM1900	voice	Front	512	1850.2	30.46	30.50	-1.39	0.17	1.009	0.17	
		Back	512	1850.2	30.46	30.50	-0.73	0.32	1.009	0.32	
	GPRS 4 slots	Front	810	1909.8	27.04	27.50	0.99	0.27	1.112	0.30	
		Back	810	1909.8	27.04	27.50	0.48	0.52	1.112	<b>0.58</b>	
WCDMA Band II	RMC	Front	9538	1907.6	23.22	23.50	0.62	0.31	1.067	0.33	
		Back	9538	1907.6	23.22	23.50	-0.05	0.62	1.067	<b>0.66</b>	
WCDMA Band IV	RMC	Front	1513	1752.6	23.12	23.50	2.57	0.19	1.091	0.21	
		Back	1513	1752.6	23.12	23.50	-0.23	0.38	1.091	<b>0.41</b>	
WCDMA Band V	RMC	Front	4182	836.4	22.98	23.00	0.64	0.10	1.005	0.10	
		Back	4182	836.4	22.98	23.00	-1.16	0.20	1.005	<b>0.20</b>	
2.4G	802.11n Ht40	Front	3	2422	17.95	18.00	0.63	0.13	1.012	0.13	
		Back	3	2422	17.95	18.00	-0.71	0.23	1.012	<b>0.23</b>	
5.2G	802.11ac HT20	Front	36	5180	16.59	17.00	2.47	0.18	1.099	0.20	
		Back	36	5180	16.59	17.00	-0.55	0.33	1.099	<b>0.36</b>	
5.8G	802.11n HT20	Front	165	5825	16.59	17.00	3.14	0.20	1.099	0.22	
		Back	165	5825	16.59	17.00	-1.65	0.34	1.099	<b>0.37</b>	



Band	Mode	Test Position with 10mm	CH.	Freq. (MHz)	RB allocation	RB offset	Ave. Power (dBm)	Tune-Up Limit (dBm)	Power Drift (%)	Meas. SAR1g (W/kg)	Scaling Factor	Reported SAR1g (W/kg)
LTE Band 2	QPSK (20MHz)	Front	18700	1860	1	49	22.88	23.00	-1.09	0.26	1.028	0.27
					50	0	21.64	22.00	1.07	0.24	1.086	0.26
		Back	18700	1860	1	49	22.88	23.00	2.18	0.51	1.028	<b>0.52</b>
					50	0	21.64	22.00	-0.21	0.48	1.086	0.52
LTE Band 4	QPSK (20MHz)	Front	20300	1745	1	49	22.67	23.00	0.34	0.35	1.079	0.38
					50	25	21.67	22.00	-1.21	0.30	1.079	0.32
		Back	20300	1745	1	49	22.67	23.00	-0.35	0.65	1.079	<b>0.70</b>
					50	25	21.67	22.00	1.06	0.60	1.079	0.65
LTE Band 5	QPSK (10MHz)	Front	20525	836.5	1	24	22.81	23.00	-2.14	0.17	1.045	0.18
					25	12	21.89	22.00	3.06	0.14	1.026	0.14
		Back	20525	836.5	1	24	22.81	23.00	-1.54	0.32	1.045	<b>0.33</b>
					25	12	21.89	22.00	2.19	0.29	1.026	0.30
LTE Band 12	QPSK (10MHz)	Front	23095	707.5	1	24	22.65	23.00	2.40	0.07	1.084	0.08
					25	12	21.75	22.00	-2.05	0.05	1.059	0.05
		Back	23095	707.5	1	24	22.65	23.00	-1.16	0.14	1.084	<b>0.15</b>
					25	12	21.75	22.00	1.08	0.10	1.059	0.11
LTE Band 17	QPSK (10MHz)	Front	23780	709	1	24	22.77	23.00	-0.65	0.11	1.054	0.12
					25	0	21.65	22.00	-0.04	0.09	1.084	0.10
		Back	23780	709	1	24	22.77	23.00	-1.36	0.21	1.054	<b>0.22</b>
					25	0	21.65	22.00	0.09	0.18	1.084	0.20

**Note:**

- Per KDB 447498 D01 v06, for each exposure position, if the highest output power channel Reported SAR  $\leq 0.8W/kg$ , other channels SAR testing is not necessary.
- Per KDB 447498 D01 v06, body-worn use is evaluated with the device positioned at 10 mm from a flat phantom filled with head tissue-equivalent medium.
- Per KDB 447498 D01 v06, the report SAR is measured SAR value adjusted for maximum tune-up tolerance. Scaling Factor =  $10^{[(\text{tune-up limit power (dBm)} - \text{Ave. power power (dBm)})/10]}$ , where tune-up limit is the maximum rated power among all production units.  
Reported SAR(W/kg) = Measured SAR (W/kg) \* Scaling Factor.
- Per KDB865664D01 v01r04 perform a second repeated measurement only the ratio of largest to smallest SAR for the original and first repeated measurement is  $>1.20$  or when the original or repeated measurement is  $\geq 1.45W/kg$ .
- Perform a second measurement only if the original, first and second repeated measurement is  $\geq 1.5w/kg$  and the ratio of largest to smallest SAR for the original, first and second repeated measurement is  $>1.20$ .

**10.2. Hotspot 1g SAR Data**

Band	Mode	Test Position with10mm	CH.	Freq. (MHz)	Ave. Power (dBm)	Tune-Up Limit (dBm)	Power Drift (%)	Meas. SAR1g (W/kg)	Scaling Factor	Reported SAR1g (W/kg)	Limit (W/Kg)
GSM850	GPRS 4 slots	Front	251	848.8	29.67	30.00	-0.61	0.32	1.079	0.35	1.60
		Back	251	848.8	29.67	30.00	3.98	0.64	1.079	<b>0.69</b>	
		Left	251	848.8	29.67	30.00	-1.51	0.03	1.079	0.03	
		Right	251	848.8	29.67	30.00	2.14	0.02	1.079	0.02	
		Bottom	251	848.8	29.67	30.00	2.63	0.01	1.079	0.01	
GSM1900	GPRS 4slots	Front	810	1909.8	27.04	27.50	-0.08	0.29	1.112	0.32	
		Back	810	1909.8	27.04	27.50	1.06	0.54	1.112	<b>0.60</b>	
		Left	810	1909.8	27.04	27.50	-1.05	0.03	1.112	0.03	
		Right	810	1909.8	27.04	27.50	2.43	0.02	1.112	0.02	
		Bottom	810	1909.8	27.04	27.50	2.09	0.01	1.112	0.01	
WCDMA Band II	RMC	Front	9538	1907.6	23.22	23.50	-1.50	0.34	1.067	0.36	
		Back	9538	1907.6	23.22	23.50	-1.10	0.64	1.067	<b>0.68</b>	
		Left	9538	1907.6	23.22	23.50	2.01	0.04	1.067	0.04	
		Right	9538	1907.6	23.22	23.50	3.57	0.02	1.067	0.02	
		Bottom	9538	1907.6	23.22	23.50	-1.06	0.01	1.067	0.01	
WCDMA Band IV	RMC	Front	1513	1752.6	23.12	23.50	2.87	0.20	1.091	0.22	
		Back	1513	1752.6	23.12	23.50	-0.80	0.40	1.091	<b>0.44</b>	
		Left	1513	1752.6	23.12	23.50	3.39	0.03	1.091	0.03	
		Right	1513	1752.6	23.12	23.50	-1.57	0.02	1.091	0.02	
		Bottom	1513	1752.6	23.12	23.50	2.09	0.01	1.091	0.01	
WCDMA Band V	RMC	Front	4182	836.4	22.98	23.00	2.06	0.11	1.005	0.11	
		Back	4182	836.4	22.98	23.00	-2.41	0.21	1.005	<b>0.21</b>	
		Left	4182	836.4	22.98	23.00	1.50	0.03	1.005	0.03	
		Right	4182	836.4	22.98	23.00	2.54	0.02	1.005	0.02	
		Bottom	4182	836.4	22.98	23.00	-3.09	0.01	1.005	0.01	

2.4G	802.11n Ht40	Front	3	2422	17.95	18.00	-1.67	0.14	1.012	0.14	<b>1.60</b>
		Back	3	2422	17.95	18.00	-1.45	0.24	1.012	<b>0.24</b>	
		Left	3	2422	17.95	18.00	2.06	0.02	1.012	0.02	
5.2G	802.11ac HT20	Front	36	5180	16.59	17.00	2.88	0.20	1.099	0.22	
		Back	36	5180	16.59	17.00	-3.53	0.35	1.099	<b>0.38</b>	
		Left	36	5180	16.59	17.00	-1.99	0.03	1.099	0.03	
5.8G	802.11n HT20	Front	165	5825	16.59	17.00	1.23	0.21	1.099	0.23	
		Back	165	5825	16.59	17.00	-2.28	0.36	1.099	<b>0.40</b>	
		Left	165	5825	16.59	17.00	2.92	0.04	1.099	0.04	

Band	Mode	Test Position with 10mm	CH.	Freq. (MHz)	RB allocation	RB offset	Ave. Power (dBm)	Tune-Up Limit (dBm)	Power Drift (%)	Meas. SAR1g (W/kg)	Scaling Factor	Reported SAR1g (W/kg)		
LTE Band 2	QPSK (20MHz)	Front	18700	1860	1	49	22.88	23.00	-2.14	0.27	1.028	0.28		
					50	0	21.64	22.00	3.01	0.25	1.086	0.27		
		Back	18700	1860	1	49	22.88	23.00	-1.03	0.55	1.028	<b>0.57</b>		
					50	0	21.64	22.00	-2.62	0.50	1.086	0.54		
		Left	18700	1860	1	49	22.88	23.00	2.62	0.03	1.028	0.03		
					50	0	21.64	22.00	1.52	0.02	1.086	0.02		
		Right	18700	1860	1	49	22.88	23.00	-1.57	0.02	1.028	0.02		
					50	0	21.64	22.00	2.30	0.01	1.086	0.01		
		Bottom	18700	1860	1	49	22.88	23.00	-2.61	0.03	1.028	0.03		
					50	0	21.64	22.00	1.63	0.02	1.086	0.02		
		LTE Band 4	QPSK (20MHz)	Front	20300	1745	1	49	22.67	23.00	-1.62	0.34	1.079	0.37
							50	25	21.67	22.00	2.04	0.30	1.079	0.32
Back	20300			1745	1	49	22.67	23.00	-0.29	0.67	1.079	<b>0.72</b>		
					50	25	21.67	22.00	2.62	0.60	1.079	0.65		
Left	20300			1745	1	49	22.67	23.00	-1.93	0.04	1.079	0.04		
					50	25	21.67	22.00	2.09	0.03	1.079	0.03		
Right	20300			1745	1	49	22.67	23.00	-1.80	0.03	1.079	0.03		
					50	25	21.67	22.00	2.03	0.02	1.079	0.02		
Bottom	20300			1745	1	49	22.67	23.00	1.32	0.02	1.079	0.02		
					50	25	21.67	22.00	1.03	0.01	1.079	0.01		

LTE Band 5	QPSK (10MHz)	Front	20525	836.5	1	24	22.81	23.00	-0.65	0.20	1.045	0.21
					25	12	21.89	22.00	2.42	0.15	1.026	0.15
		Back	20525	836.5	1	24	22.81	23.00	-1.09	0.35	1.045	<b>0.37</b>
					25	12	21.89	22.00	1.63	0.30	1.026	0.31
		Left	20525	836.5	1	24	22.81	23.00	2.09	0.04	1.045	0.04
					25	12	21.89	22.00	-1.38	0.02	1.026	0.02
		Right	20525	836.5	1	24	22.81	23.00	2.85	0.03	1.045	0.03
					25	12	21.89	22.00	-1.52	0.02	1.026	0.02
		Bottom	20525	836.5	1	24	22.81	23.00	-0.68	0.02	1.045	0.02
					25	12	21.89	22.00	2.62	0.01	1.026	0.01
LTE Band 12	QPSK (10MHz)	Front	23095	707.5	1	24	22.65	23.00	-1.50	0.08	1.084	0.09
					25	12	21.75	22.00	2.05	0.07	1.059	0.07
		Back	23095	707.5	1	24	22.65	23.00	-0.46	0.16	1.084	<b>0.17</b>
					25	12	21.75	22.00	-3.61	0.14	1.059	0.15
		Left	23095	707.5	1	24	22.65	23.00	-2.41	0.02	1.084	0.02
					25	12	21.75	22.00	3.62	0.01	1.059	0.01
		Right	23095	707.5	1	24	22.65	23.00	2.41	0.03	1.084	0.03
					25	12	21.75	22.00	3.32	0.02	1.059	0.02
		Bottom	23095	707.5	1	24	22.65	23.00	1.26	0.02	1.084	0.02
					25	12	21.75	22.00	-3.54	0.01	1.059	0.01
LTE Band 17	QPSK (10MHz)	Front	23780	709	1	24	22.77	23.00	-1.06	0.12	1.054	0.13
					25	0	21.65	22.00	2.21	0.10	1.084	0.11
		Back	23780	709	1	24	22.77	23.00	3.61	0.24	1.054	<b>0.25</b>
					25	0	21.65	22.00	-1.62	0.20	1.084	0.22
		Left	23780	709	1	24	22.77	23.00	2.51	0.02	1.054	0.02
					25	0	21.65	22.00	-2.29	0.01	1.084	0.01
		Right	23780	709	1	24	22.77	23.00	2.86	0.02	1.054	0.02
					25	0	21.65	22.00	-1.44	0.01	1.084	0.01
		Bottom	23780	709	1	24	22.77	23.00	0.35	0.03	1.054	0.03
					25	0	21.65	22.00	-2.54	0.02	1.084	0.02

**Note:**

- Per KDB 447498 D01 v06, for each exposure position, if the highest output power channel Reported SAR  $\leq 0.8W/kg$ , other channels SAR testing is not necessary.
- Per KDB 447498 D01 v06, body-worn with hotspot use is evaluated with the device positioned at 10 mm from a flat phantom filled with head tissue-equivalent medium.
- Per KDB 447498 D01 v06, the report SAR is measured SAR value adjusted for maximum tune-up tolerance. Scaling Factor =  $10^{\frac{(\text{tune-up limit power(dBm)} - \text{Ave. power (dBm)})}{10}}$ , where tune-up limit is the maximum rated power among all production units.  
Reported SAR(W/kg) = Measured SAR (W/kg) \* Scaling Factor.
- Per KDB865664D01 v01r04 perform a second repeated measurement only the ratio of largest to smallest SAR for the original and first repeated measurement is  $>1.20$  or when the original or repeated measurement is  $\geq 1.45W/kg$ .
- Perform a second measurement only if the original, first and second repeated measurement is  $\geq 1.5w/kg$  and the ratio of largest to smallest SAR for the original, first and second repeated measurement is  $>1.20$ .

### 10.3. Simultaneous Transmission Conclusion

#### Multi-Band Simultaneous Transmission Considerations

According to FCC KDB Publication 447498 D01v05r02, transmitters are considered to be transmitting simultaneously when there is overlapping transmission, with the exception of transmissions during network hand-offs with maximum hand-off duration less than 30 seconds. Possible transmission paths for the EUT are shown in below Figure and are color-coded to indicate communication modes which share the same path. Modes which share the same transmission path cannot transmit simultaneously with one another.



#### Simultaneous Transmission Procedures

This device contains transmitters that may operate simultaneously. Therefore simultaneous transmission analysis is required. Per FCC KDB 447498 D01v05r02, simultaneous transmission SAR test exclusion may be applied when the sum of the 1-g SAR for all the simultaneous transmitting antennas in a specific a physical test configuration is  $\leq 1.6$  W/kg. When standalone SAR is not required to be measured, per FCC KDB 447498 D01v05r02 4.3.2.2), the following equation must be used to estimate the standalone 1g SAR and 10g extremity SAR for simultaneous transmission assessment involving that transmitter.

$$\text{Estimated SAR} = \frac{\sqrt{f(\text{GHz})}}{7.5(18.75)} \cdot \frac{\text{Max. power of channel, mW}}{\text{Min. Separation Distance, mm}}$$

Mode	Max. tune-up Power (dBm)	Exposure Position	Head	Body -worn
		Test Distance (mm)	5	5
BT	3.16	Estimated SAR (W/kg)	/	0.13

**Note:**

- When the minimum *test separation distance* is  $< 5$  mm, a distance of 5 mm according is applied to determine estimated SAR.
- (max. power of channel, including tune-up tolerance, mW)/(min. test separation distance, mm)  $\cdot$   $[\sqrt{f(\text{GHz})}/x]$  W/kg for test separation distances  $\leq 5$  mm; where  $x = 7.5$  for 1-g SAR, and  $x = 18.75$  for 10-g SAR.
- Next to the mouth exposure requires 1-g SAR, and the wrist-worn condition requires 10-g extremity SAR.

**Simultaneous Transmission Possibilities**

The Simultaneous Transmission Possibilities of this device are as below:

NO.	Configuration	Head	Body-Worn	Hotspot
1	GSM850/1900(Voice)+WIFI(2.4)	YES	YES	NO
2	GPRS 850/1900(DATA)+WIFI(2.4)	YES	YES	YES
3	WCDMA+ WIFI(2.4)	YES	YES	YES
4.	LTE+WIFI(2.4)	YES	YES	YES
5.	GSM850/1900(Voice)+BT	YES	YES	NO
6	GPRS/EDGE 850/1900(DATA)+BT	YES	YES	NO
7.	WCDMA+ BT	YES	YES	NO
8.	LTE+BT	YES	YES	NO

### 10.4. SAR Simultaneous Transmission Analysis

Band	Test Position	Scaled SAR			Σ SAR (W/kg)	SPLSR	Remark
		Body-Worn	WIFI 5G	BT			
GSM850 (voice)	Front	0.19	0.22	0.13	0.41	N/A	N/A
	Back	0.36	0.37	0.13	0.73	N/A	N/A
GSM850 (GPRS 4slot)	Front	0.33	0.22	0.13	0.55	N/A	N/A
	Back	0.67	0.37	0.13	1.04	N/A	N/A
GSM1900 (voice)	Front	0.17	0.22	0.13	0.39	N/A	N/A
	Back	0.32	0.37	0.13	0.69	N/A	N/A
GSM1900 (GPRS 4slot)	Front	0.30	0.22	0.13	0.52	N/A	N/A
	Back	0.58	0.37	0.13	0.95	N/A	N/A
WCDMA Band II	Front	0.33	0.22	0.13	0.55	N/A	N/A
	Back	0.66	0.37	0.13	1.03	N/A	N/A
WCDMA Band IV	Front	0.21	0.22	0.13	0.43	N/A	N/A
	Back	0.41	0.37	0.13	0.78	N/A	N/A
WCDMA Band V	Front	0.10	0.22	0.13	0.32	N/A	N/A
	Back	0.20	0.37	0.13	0.57	N/A	N/A

Band	Test Position	RB allocation	Scaled			Σ SAR (W/kg)	SPLSR	Remark
			Body-Worn	WIFI 5G	Bluetooth			
LTE Band 2 QPSK (20MHz)	Front	1	0.27	0.22	0.13	0.49	N/A	N/A
		50	0.26	0.22	0.13	0.48	N/A	N/A
	Back	1	0.52	0.37	0.13	0.89	N/A	N/A
		50	0.52	0.37	0.13	0.89	N/A	N/A
LTE Band 4 QPSK (20MHz)	Front	1	0.38	0.22	0.13	0.60	N/A	N/A
		50	0.32	0.22	0.13	0.54	N/A	N/A
	Back	1	0.70	0.37	0.13	<b>1.07</b>	N/A	N/A
		50	0.65	0.37	0.13	1.02	N/A	N/A
LTE Band 5 QPSK (10MHz)	Front	1	0.18	0.22	0.13	0.40	N/A	N/A
		25	0.14	0.22	0.13	0.36	N/A	N/A
	Back	1	0.33	0.37	0.13	0.70	N/A	N/A
		25	0.30	0.37	0.13	0.67	N/A	N/A

LTE Band 12 QPSK (10MHz)	Front	1	0.08	0.22	0.13	0.30	N/A	N/A
		25	0.05	0.22	0.13	0.27	N/A	N/A
	Back	1	0.15	0.37	0.13	0.52	N/A	N/A
		25	0.11	0.37	0.13	0.48	N/A	N/A
LTE Band 17 QPSK (10MHz)	Front	1	0.12	0.22	0.13	0.34	N/A	N/A
		25	0.10	0.22	0.13	0.32	N/A	N/A
	Back	1	0.22	0.37	0.13	0.59	N/A	N/A
		25	0.20	0.37	0.13	0.57	N/A	N/A

Band	Test Position	Scaled SAR		Σ SAR (W/kg)	SPLSR	Remark
		Hotspot	WIFI 5G			
GSM850 (GPRS)	Front	0.35	0.23	0.58	N/A	N/A
	Back	0.69	0.40	1.09	N/A	N/A
	Left	0.03	0.04	0.07	N/A	N/A
	Right	0.02	/	0.02	N/A	N/A
	Bottom	0.01	/	0.01	N/A	N/A
GSM1900(G PRS)	Front	0.32	0.23	0.55	N/A	N/A
	Back	0.60	0.40	1.00	N/A	N/A
	Left	0.03	0.04	0.07	N/A	N/A
	Right	0.02	/	0.02	N/A	N/A
	Bottom	0.01	/	0.01	N/A	N/A
WCDMA Band II	Front	0.36	0.23	0.59	N/A	N/A
	Back	0.68	0.40	1.08	N/A	N/A
	Left	0.04	0.04	0.08	N/A	N/A
	Right	0.02	/	0.02	N/A	N/A
	Bottom	0.01	/	0.01	N/A	N/A
WCDMA Band IV	Front	0.22	0.23	0.45		
	Back	0.44	0.40	0.84		
	Left	0.03	0.04	0.07		
	Right	0.02	/	0.02		
	Bottom	0.01	/	0.01		
WCDMA Band V	Front	0.11	0.23	0.34	N/A	N/A
	Back	0.21	0.40	0.61	N/A	N/A
	Left	0.03	0.04	0.07	N/A	N/A
	Right	0.02	/	0.02	N/A	N/A
	Bottom	0.01	/	0.01	N/A	N/A



Band	Test Position	RB allocation	Scaled		$\Sigma$ SAR (W/kg)	SPLSR	Remark
			Hotspot	WIFI 5G			
LTE Band 2 QPSK (20MHz)	Front	1	0.28	0.23	0.51	N/A	N/A
		50	0.27	0.23	0.50	N/A	N/A
	Back	1	0.57	0.40	0.97	N/A	N/A
		50	0.54	0.40	0.94	N/A	N/A
	Left	1	0.03	0.04	0.07	N/A	N/A
		50	0.02	0.04	0.06	N/A	N/A
	Right	1	0.02	/	0.02	N/A	N/A
		50	0.01	/	0.01	N/A	N/A
	Bottom	1	0.03	/	0.03	N/A	N/A
		50	0.02	/	0.02	N/A	N/A
LTE Band 4 QPSK (20MHz)	Front	1	0.37	0.23	0.60	N/A	N/A
		50	0.32	0.23	0.55	N/A	N/A
	Back	1	0.72	0.40	1.12	N/A	N/A
		50	0.65	0.40	1.05	N/A	N/A
	Left	1	0.04	0.04	0.08	N/A	N/A
		50	0.03	0.04	0.07	N/A	N/A
	Right	1	0.03	/	0.03	N/A	N/A
		50	0.02	/	0.02	N/A	N/A
	Bottom	1	0.02	/	0.02	N/A	N/A
		50	0.01	/	0.01	N/A	N/A
LTE Band 5 QPSK (10MHz)	Front	1	0.21	0.23	0.44	N/A	N/A
		25	0.15	0.23	0.38	N/A	N/A
	Back	1	0.37	0.40	0.77	N/A	N/A
		25	0.31	0.40	0.71	N/A	N/A
	Left	1	0.04	0.04	0.08	N/A	N/A
		25	0.02	0.04	0.06	N/A	N/A
	Right	1	0.03	/	0.03	N/A	N/A
		25	0.02	/	0.02	N/A	N/A
	Bottom	1	0.02	/	0.02	N/A	N/A
		25	0.01	/	0.01	N/A	N/A

LTE Band 12 QPSK (10MHz)	Front	1	0.09	0.23	0.32	N/A	N/A	
		25	0.07	0.23	0.3	N/A	N/A	
	Back	1	0.17	0.40	0.57	N/A	N/A	
		25	0.15	0.40	0.55	N/A	N/A	
	Left	1	0.02	0.04	0.06	N/A	N/A	
		25	0.01	0.04	0.05	N/A	N/A	
	Right	1	0.03	/	0.03	N/A	N/A	
		25	0.02	/	0.02	N/A	N/A	
	Bottom	1	0.02	/	0.02	N/A	N/A	
		25	0.01	/	0.01	N/A	N/A	
	LTE Band 17 QPSK (10MHz)	Front	1	0.13	0.23	0.36	N/A	N/A
			25	0.11	0.23	0.34	N/A	N/A
Back		1	0.25	0.40	0.65	N/A	N/A	
		25	0.22	0.40	0.62	N/A	N/A	
Left		1	0.02	0.04	0.06	N/A	N/A	
		25	0.01	0.04	0.05	N/A	N/A	
Right		1	0.02	/	0.02	N/A	N/A	
		25	0.01	/	0.01	N/A	N/A	
Bottom		1	0.03	/	0.03	N/A	N/A	
		25	0.02	/	0.02	N/A	N/A	

### Simultaneous Transmission Conclusion

The above numerical summed SAR results for all the case simultaneous transmission conditions were below the SAR limit. Therefore, the above analysis is sufficient to determine that simultaneous transmission cases will not exceed the SAR limit and therefore measured volumetric simultaneous SAR summation is not required per FCC KDB Publication 447498 D01v05r02.

### 10.5. Measurement Uncertainty (450MHz-3GHz)

UNCERTAINTY EVALUATION FOR HEADSET SAR									
Uncertainty Component	Description	Uncertainty Value(%)	Probably Distribution	Div.	(Ci) 1g	(Ci) 10g	Std. Unc. 1g(%)	Std. Unc. 10g(%)	v
<b>Measurement system</b>									
Probe calibration	7.2.1	5.8	N	1	1	1	5.8	5.8	∞
Axial isotropy	7.2.1.1	3.5	R	$\sqrt{3}$	$(1-C_p)^{1/2}$	$(1-C_p)^{1/2}$	1.43	1.43	∞
Hemispherical isotropy	7.2.1.1	5.9	R	$\sqrt{3}$	$\sqrt{C_p}$	$\sqrt{C_p}$	2.41	2.41	∞
Boundary Effects	7.2.1.4	1.00	R	$\sqrt{3}$	1	1	0.58	0.58	∞
Linearity	7.2.1.2	4.70	R	$\sqrt{3}$	1	1	2.71	2.71	∞
System detection limits	7.2.1.2	1	R	$\sqrt{3}$	1	1	0.58	0.58	∞
Modulation Response	7.2.1.3	3	N	1	1	1	3.00	3.00	∞
Readout Electronics	7.2.1.5	0.5	N	1	1	1	0.50	0.50	∞
Response Time	7.2.1.6	0	R	$\sqrt{3}$	1	1	0.00	0.00	∞
Integration Time	7.2.1.7	1.4	R	$\sqrt{3}$	1	1	0.81	0.81	∞
RF Ambient Conditions-Noise	7.2.3.7	3	R	$\sqrt{3}$	1	1	1.73	1.73	∞
RF Ambient Conditions-Reflection	7.2.3.7	3	R	$\sqrt{3}$	1	1	1.73	1.73	∞
Probe positioned mechanical Tolerance	7.2.2.1	1.4	R	$\sqrt{3}$	1	1	0.81	0.81	∞
Probe positioning with respect to phantom shell	7.2.2.3	1.4	R	$\sqrt{3}$	1	1	0.81	0.81	∞
Extrapolation interpolation and integration algorithms for Max.SAR evaluation	7.2.4	2.3	R	1	1	1	1.33	1.33	∞
<b>Test sample related</b>									
Test sample positioning	7.2.2.4.4	2.6	N	1	1	1	2.60	2.60	∞
Device holder uncertainty	7.2.2.4.2 7.2.2.4.3	3	N	1	1	1	3.00	3.00	∞
output power variation-SAR drift measurement	7.2.3.6	5	R	$\sqrt{3}$	1	1	2.89	2.89	∞
SAR scaling	7.2.5	2	R	$\sqrt{3}$	1	1	1.15	1.15	∞
<b>Phantom and tissue parameters</b>									
Phantom uncertainty (shape and thickness tolerances)	7.2.2.2	4	R	$\sqrt{3}$	1	1	2.31	2.31	∞
uncertainty in SAR correction for deviation (in permittivity and conductivity)	7.2.6	2	N	1	1	0.84	2.00	1.68	∞
Liquid conductivity (temperature uncertainty)	7.2.3.5	2.5	N	1	0.78	0.71	1.95	1.78	∞
Liquid conductivity -measurement uncertainty	7.2.3.3	4	N	1	0.23	0.26	0.92	1.04	∞
Liquid permittivity (temperature uncertainty)	7.2.3.5	2.5	N	1	0.78	0.71	1.95	1.78	∞
Liquid permittivity measurement uncertainty	7.2.3.4	5	N	1	0.23	0.26	1.15	1.30	∞
Combined standard uncertainty			RSS				10.83	10.54	
Expanded uncertainty (95%CONFIDENCEINTERVAL)			k				21.26	21.08	

**UNCERTAINTY FOR PERFORMANCE CHECK**

Uncertainty Component	Description	Uncertainty Value(%)	Probably Distribution	Div.	(Ci) 1g	(Ci) 10g	Std. Unc. 1g(%)	Std. Unc. 10g(%)	v
<b>Measurement system</b>									
Probe calibration	7.2.1	5.8	N	1	1	1	5.8	5.8	∞
Axial isotropy	7.2.1.1	3.5	R	$\sqrt{3}$	$(1-C_p)^{1/2}$	$(1-C_p)^{1/2}$	1.43	1.43	∞
Hemispherical isotropy	7.2.1.1	5.9	R	$\sqrt{3}$	$\sqrt{C_p}$	$\sqrt{C_p}$	2.41	2.41	∞
Boundary Effects	7.2.1.4	1.00	R	$\sqrt{3}$	1	1	0.58	0.58	∞
Linearity	7.2.1.2	4.70	R	$\sqrt{3}$	1	1	2.71	2.71	∞
System detection limits	7.2.1.2	1	R	$\sqrt{3}$	1	1	0.58	0.58	∞
Modulation Response	7.2.1.3	3	N	1	1	1	0.00	0.00	∞
Readout Electronics	7.2.1.5	0.5	N	1	1	1	0.50	0.50	∞
Response Time	7.2.1.6	0	R	$\sqrt{3}$	1	1	0.00	0.00	∞
Integration Time	7.2.1.7	1.4	R	$\sqrt{3}$	1	1	0.81	0.81	∞
RF Ambient Conditions-Noise	7.2.3.7	3	R	$\sqrt{3}$	1	1	1.73	1.73	∞
RF Ambient Conditions-Reflection	7.2.3.7	3	R	$\sqrt{3}$	1	1	1.73	1.73	∞
Probe positioned mechanical Tolerance	7.2.2.1	1.4	R	$\sqrt{3}$	1	1	0.81	0.81	∞
Probe positioning with respect to phantom shell	7.2.2.3	1.4	R	$\sqrt{3}$	1	1	0.81	0.81	∞
Extrapolation interpolation and integration algorithms for Max.SAR evaluation	7.2.4	2.3	R	1	1	1	1.33	1.33	∞
<b>Dipole</b>									
Deviation of experimental source from numerical source		4	N	1	1	1	4.00	4.00	∞
Input power and SAR drift measurement	7.2.3.6	5	R	$\sqrt{3}$	1	1	2.89	2.89	∞
Dipole axis to liquid distance		2	R	$\sqrt{3}$	1	1			∞
<b>Phantom and tissue parameters</b>									
Phantom uncertainty (shape and thickness tolerances)	7.2.2.2	4	R	$\sqrt{3}$	1	1	2.31	2.31	∞
uncertainty in SAR correction for deviation (in permittivity and conductivity)	7.2.6	2	N	1	1	0.84	2.00	1.68	∞
Liquid conductivity (temperature uncertainty)	7.2.3.5	2.5	N	1	0.78	0.71	1.95	1.78	∞
Liquid conductivity -measurement uncertainty	7.2.3.3	4	N	1	0.23	0.26	0.92	1.04	∞
Liquid permittivity (temperature uncertainty)	7.2.3.5	2.5	N	1	0.78	0.71	1.95	1.78	∞
Liquid permittivity measurement uncertainty	7.2.3.4	5	N	1	0.23	0.26	1.15	1.30	∞
Combined standard uncertainty			RSS				10.15	10.05	
Expanded uncertainty (95%CONFIDENCEINTERVAL			k				20.29	20.10	

### 10.6. Test Equipment List

Test Equipment	Manufacturer	Model	Serial Number	Calibration	
				Calibration Date (D.M.Y)	Calibration Due (D.M.Y)
PC	Lenovo	H3050	N/A	N/A	N/A
Signal Generator	Agilent	N5182A	MY47070282	Jul. 08, 2021	Jul. 07, 2022
Multimeter	Keithley	Multimeter 2000	4078275	Jul. 08, 2021	Jul. 07, 2022
Network Analyzer	Agilent	8753E	US38432457	Jul. 08, 2021	Jul. 07, 2022
Wireless Communication Test Set	R & S	CMU200	111382	Jul. 08, 2021	Jul. 07, 2022
Wideband Radio Communication Tester	R&S	CMW500	114220	Jul. 08, 2021	Jul. 07, 2022
Power Meter	Agilent	E4418B	GB43312526	Jul. 08, 2021	Jul. 07, 2022
Power Meter	Agilent	E4416A	MY45101555	Jul. 08, 2021	Jul. 07, 2022
Power Meter	Agilent	N1912A	MY50001018	Jul. 08, 2021	Jul. 07, 2022
Power Sensor	Agilent	E9301A	MY41497725	Jul. 08, 2021	Jul. 07, 2022
Power Sensor	Agilent	E9327A	MY44421198	Jul. 08, 2021	Jul. 07, 2022
Power Sensor	Agilent	E9323A	MY53070005	Jul. 08, 2021	Jul. 07, 2022
Power Amplifier	PE	PE15A4019	112342	N/A	N/A
Directional Coupler	Agilent	722D	MY52180104	N/A	N/A
Attenuator	Chensheng	FF779	134251	N/A	N/A
E-Field PROBE	MVG	SSE2	SN 36/20 EPGO346	Oct. 08, 2021	Oct. 07, 2022
DIPOLE 750	MVG	SID750	SN 16/15 DIP 0G750-368	Jun. 05, 2021	Jun. 04, 2024
DIPOLE 835	MVG	SID835	SN 16/15 DIP 0G835-369	Jun. 05, 2021	Jun. 04, 2024
DIPOLE 1800	MVG	SID 1800	SN 16/15 DIP 1G800-371	Jun. 05, 2021	Jun. 04, 2024
DIPOLE 1900	MVG	SID1900	SN 16/15 DIP 1G900-372	Jun. 05, 2021	Jun. 04, 2024
DIPOLE 2450	MVG	SID 2450	SN 16/15 DIP 2G450-374	Jun. 05, 2021	Jun. 04, 2024
DIPOLE 5G	MVG	SID 5G	SN 13/14 WGA32	May 15, 2021	May 14, 2024
Limesar Dielectric Probe	MVG	SCLMP	SN 19/15 OCPG71	Jun. 05, 2021	Jun. 04, 2024
Communication Antenna	MVG	ANTA59	SN 39/14 ANTA59	N/A	N/A
Mobile Phone Position Device	MVG	MSH101	SN 19/15 MSH101	N/A	N/A
Dummy Probe	MVG	DP66	SN 13/15 DP66	N/A	N/A
SAM PHANTOM	MVG	SAM120	SN 19/15 SAM120	N/A	N/A
PHANTOM TABLE	MVG	TABP101	SN 19/15 TABP101	N/A	N/A
Robot TABLE	MVG	TABP61	SN 19/15 TABP61	N/A	N/A
6 AXIS ROBOT	KUKA	KR6-R900	501822	N/A	N/A

- Note:**
1. N/A means this equipment no need to calibrate
  2. Each Time means this device need to calibrate every use time
  3. The dipole was not damaged properly repaired.
  4. The measured SAR deviates from the calibrated SAR value by less than 10%
  5. The most recent return-loss result meets the required 20 dB minimum return-loss requirement
  6. The most recent measurement of the real or imaginary parts of the impedance deviates by less than 5 Ω from the previous measurement.

## 11. System Check Results

Date of measurement: 11/26/2021 Test mode: 750 (Body)

Product Description: Validation

Dipole Model: SID750

E-Field Probe: SSE2 (SN 36/20 EPGO346)

Phantom	Validation plane
Input Power	100mW
Crest Factor	1.0
Probe Conversion factor	1.78
Frequency (MHz)	750.000000
Relative permittivity (real part)	55.501166
Relative permittivity (imaginary part)	20.148160
Conductivity (S/m)	0.961243
Variation (%)	-0.150000
<b>SAR 10g (W/Kg)</b>	<b>0.562014</b>
<b>SAR 1g (W/Kg)</b>	<b>0.832441</b>

### SURFACE SAR

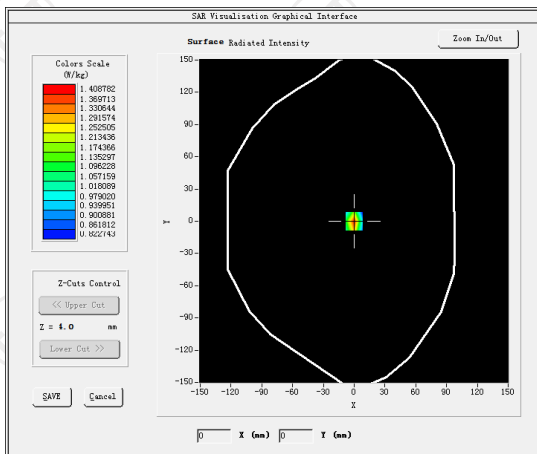

### VOLUME SAR

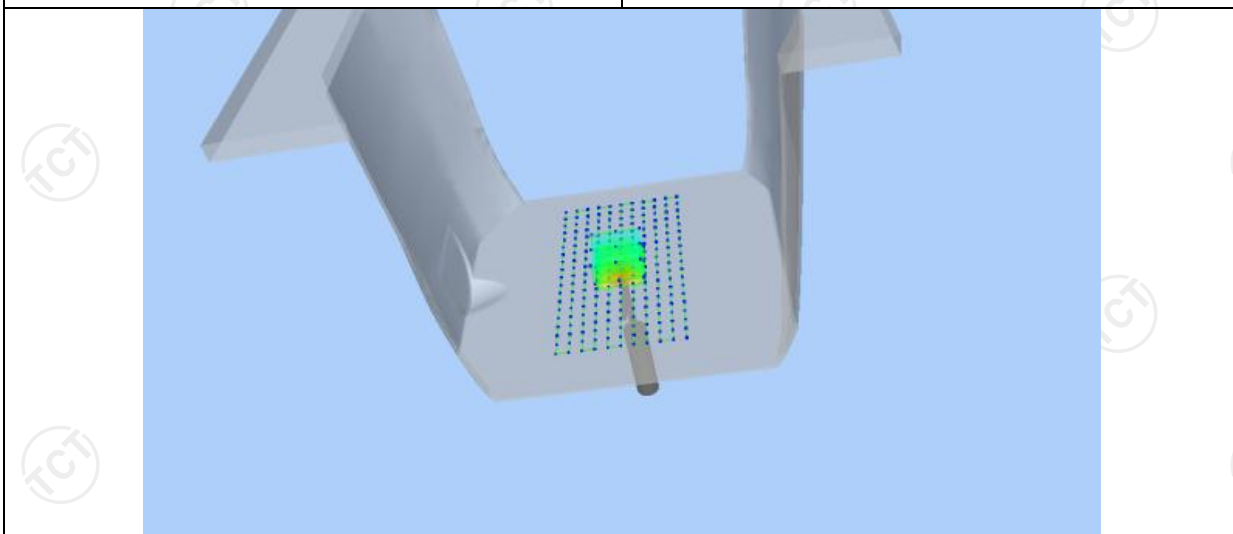
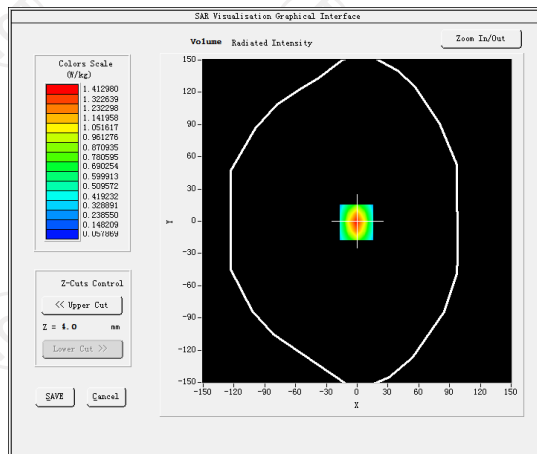

Z (mm)	0.00	4.00	9.00	14.00	19.00
SAR (W/Kg)	1.014	0.4420	0.3029	0.2419	0.2240

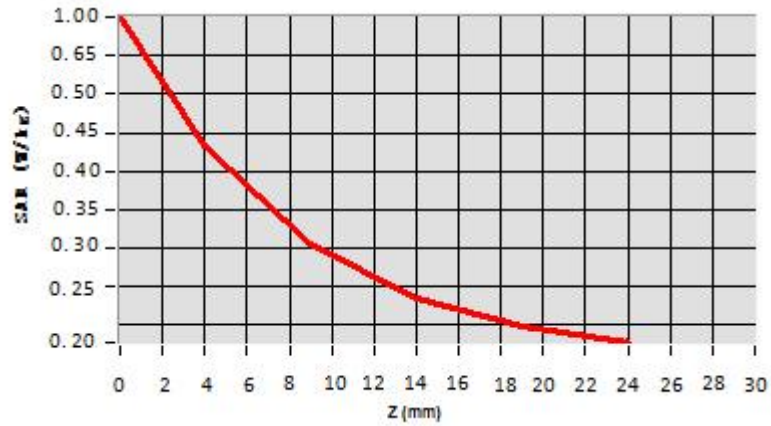

**Hot spot position**



Date of measurement: 11/29/2021 Test mode: 835 (Body)  
 Product Description: Validation  
 Dipole Model: SID835  
 E-Field Probe: SSE2 (SN 36/20 EPGO346)

Phantom	Validation plane
Input Power	100mW
Crest Factor	1.0
Probe Conversion factor	1.78
Frequency (MHz)	835.000000
Relative permittivity (real part)	55.242077
Relative permittivity (imaginary part)	21.378187
Conductivity (S/m)	0.938883
Variation (%)	-0.150000
<b>SAR 10g (W/Kg)</b>	<b>0.633123</b>
<b>SAR 1g (W/Kg)</b>	<b>0.949446</b>

### SURFACE SAR

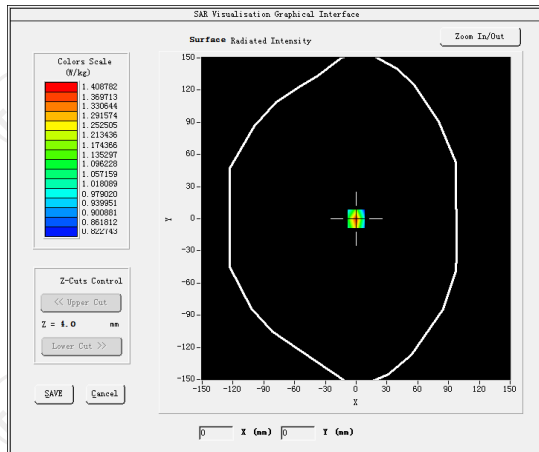

### VOLUME SAR

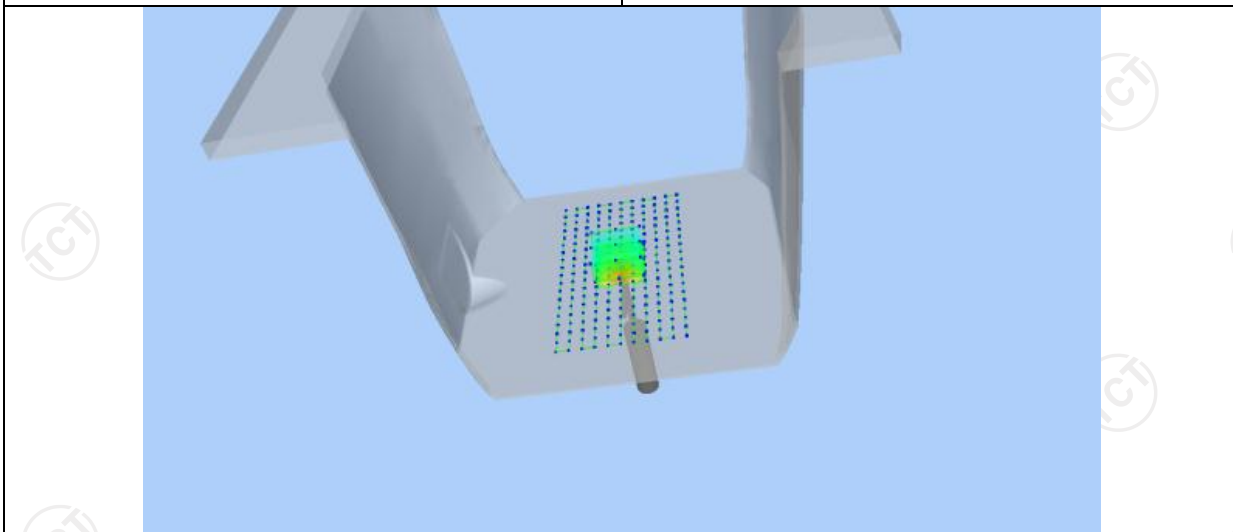
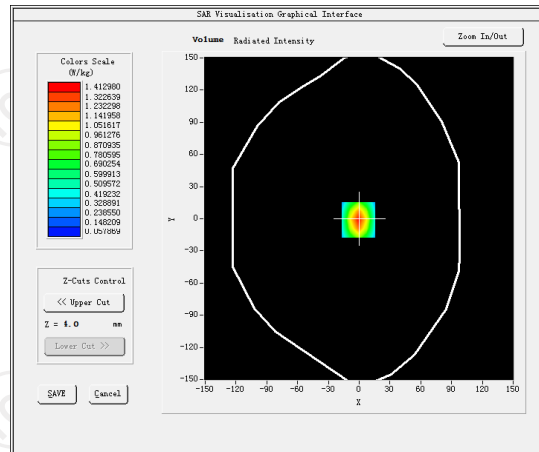



Z (mm)	0.00	4.00	9.00	14.00	19.00
SAR (W/Kg)	0.9625	0.6022	0.3594	0.2202	0.0725

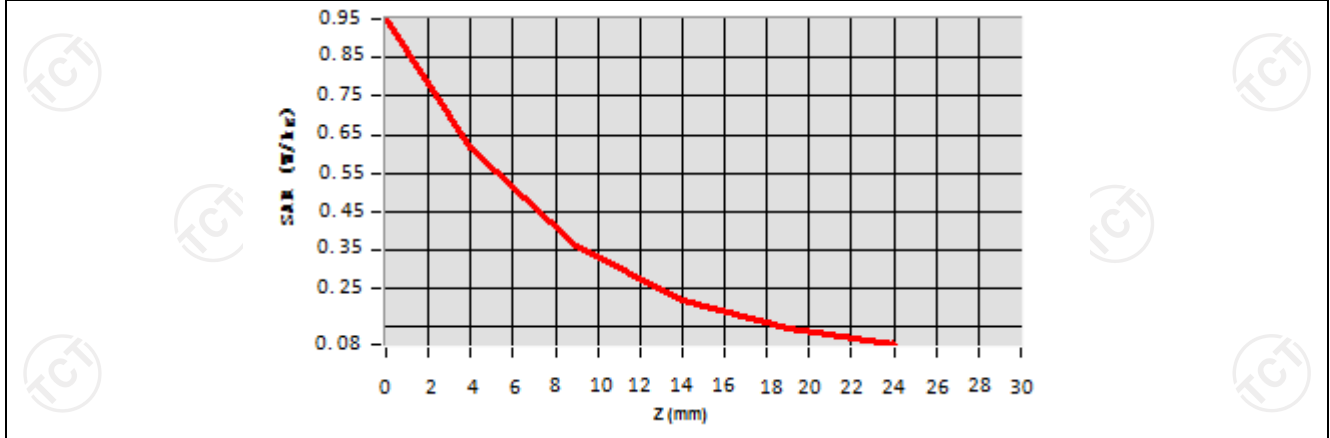

**Hot spot position**

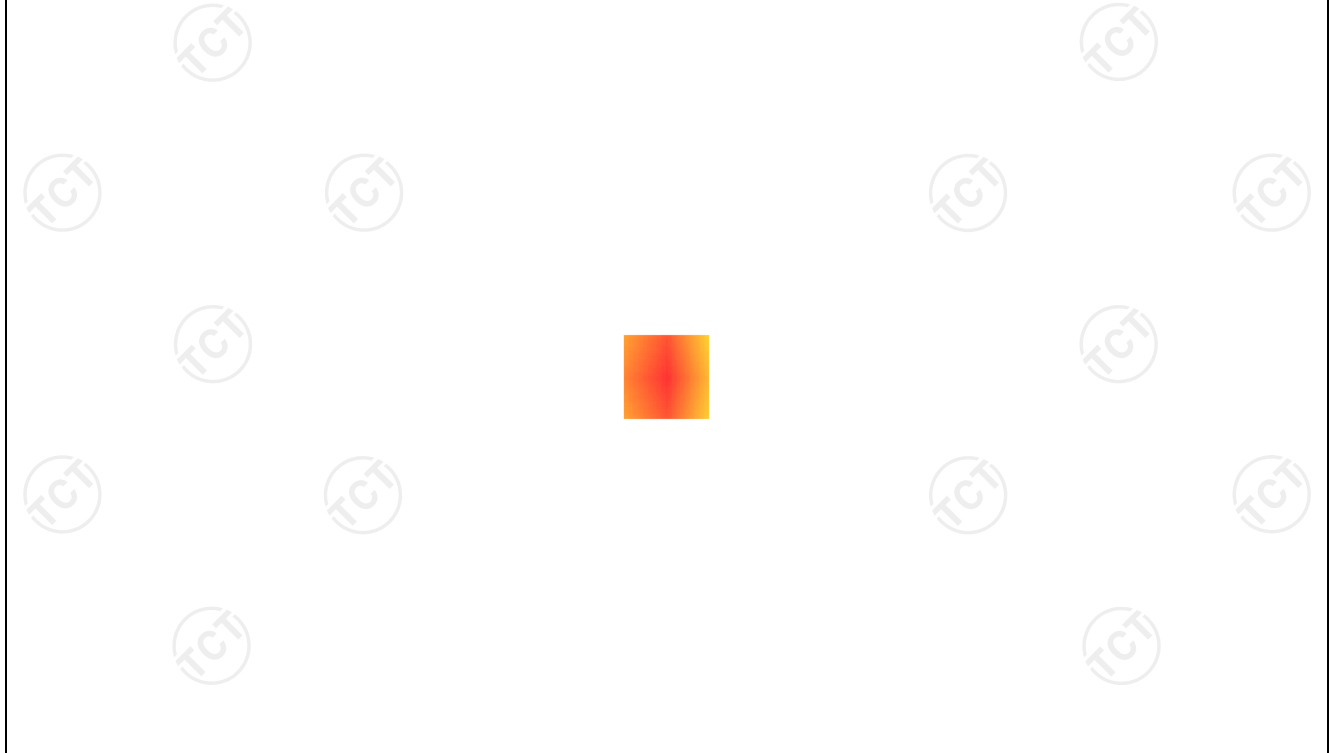

Date of measurement: 12/01/2021 Test mode: 1800MHz (Body)

Product Description: Validation

Dipole Model: SID1800

E-Field Probe: SSE2 (SN 36/20 EPGO346)

Phantom	Validation plane
Input Power	100mW
Crest Factor	1.0
Probe Conversion factor	2.16
Frequency (MHz)	1800.000000
Relative permittivity (real part)	53.292699
Relative permittivity (imaginary part)	15.200000
Conductivity (S/m)	1.530000
Variation (%)	3.050000
<b>SAR 10g (W/Kg)</b>	<b>2.053687</b>
<b>SAR 1g (W/Kg)</b>	<b>3.782547</b>

### SURFACE SAR

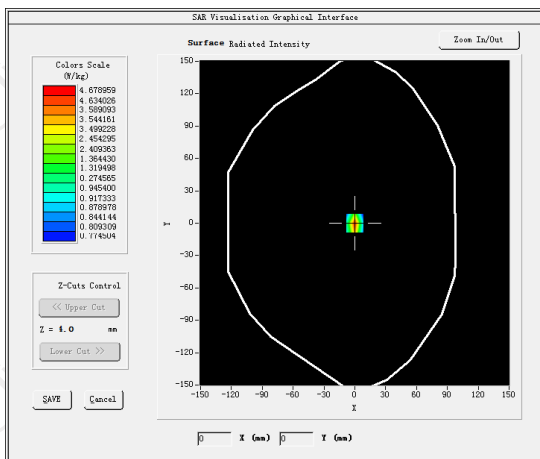

### VOLUME SAR

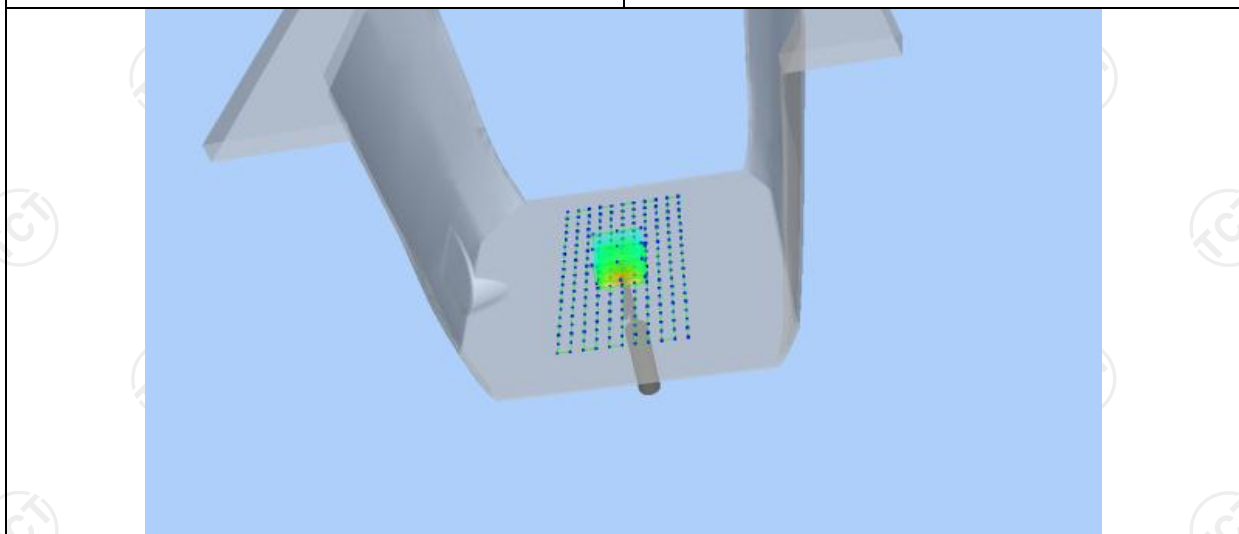
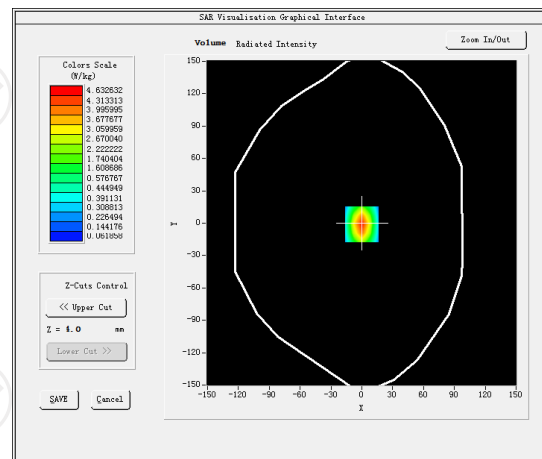

Z (mm)	0.00	4.00	9.00	14.00	19.00
SAR (W/Kg)	3.7545	2.4524	1.3520	0.8214	0.5525

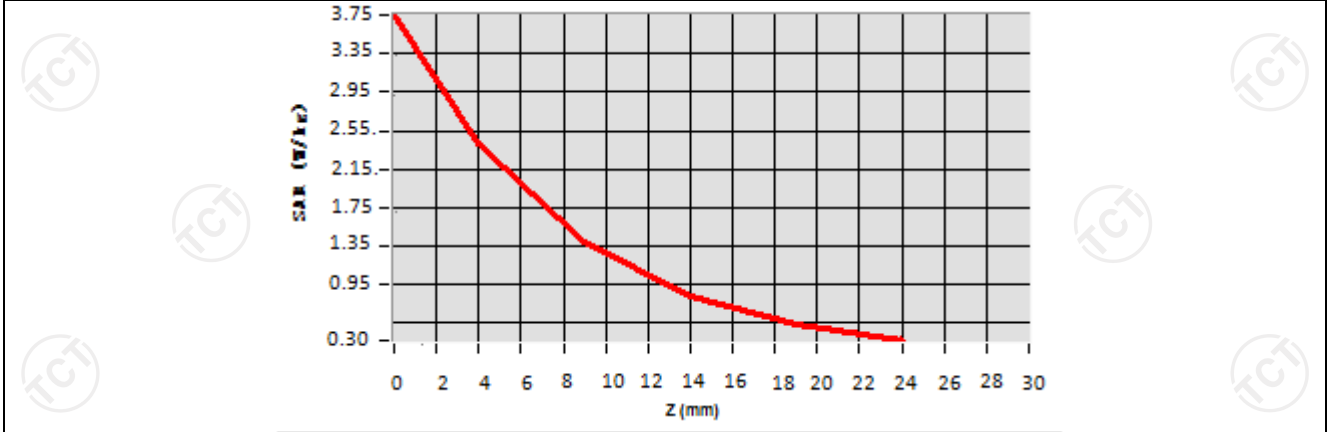

**Hot spot position**

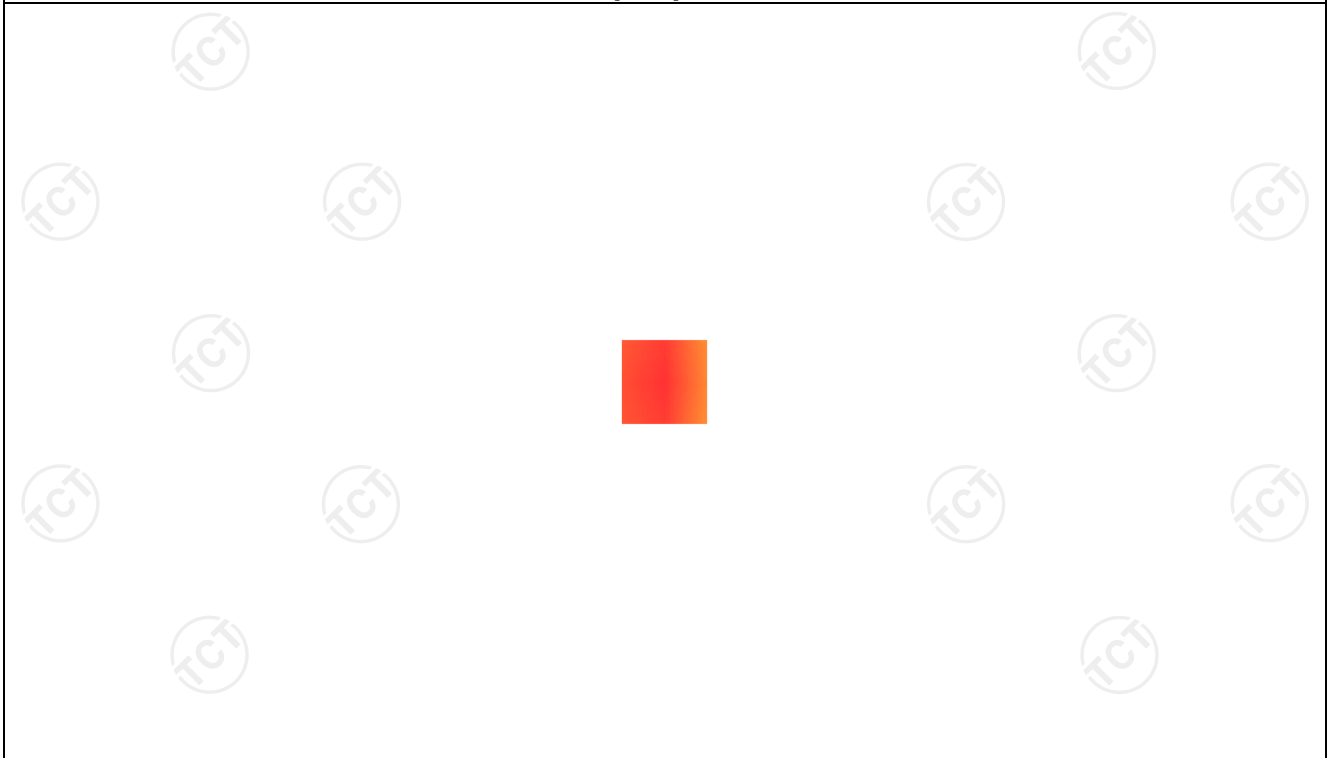

Date of measurement: 12/07/2021 Test mode: 1900MHz (Body)

Product Description: Validation

Dipole Model: SID1900

E-Field Probe: SSE2 (SN 36/20 EPGO346)

Phantom	Validation plane
Input Power	100mW
Crest Factor	1.0
Probe Conversion factor	2.16
Frequency (MHz)	1900.000000
Relative permittivity (real part)	53.309999
Relative permittivity (imaginary part)	14.329440
Conductivity (S/m)	1.510354
Variation (%)	1.250000
<b>SAR 10g (W/Kg)</b>	<b>1.994255</b>
<b>SAR 1g (W/Kg)</b>	<b>3.766112</b>

**SURFACE SAR**

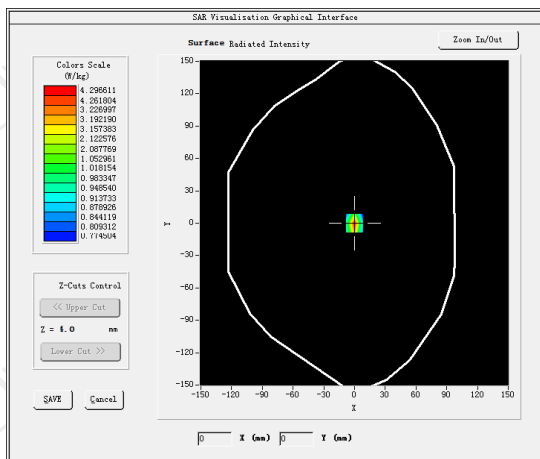

**VOLUME SAR**

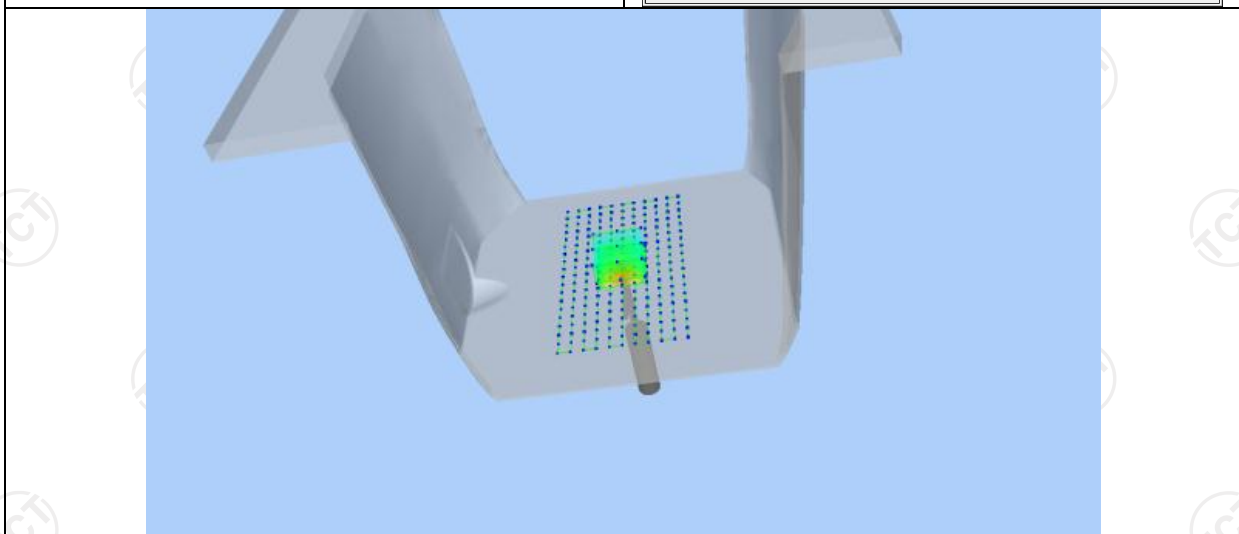
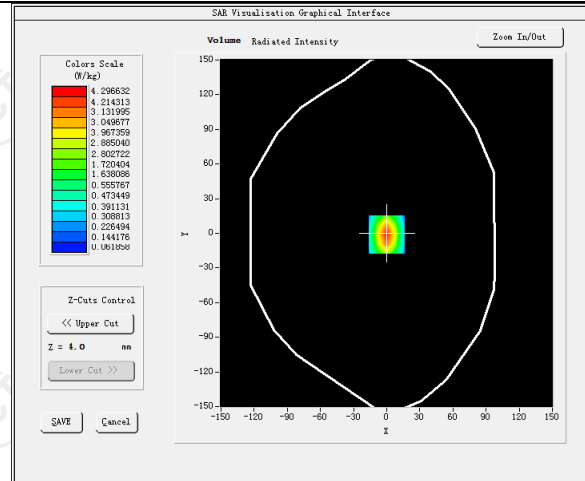

Z (mm)	0.00	4.00	9.00	14.00	19.00
SAR (W/Kg)	3.7752	2.7154	1.9525	1.5694	0.9014

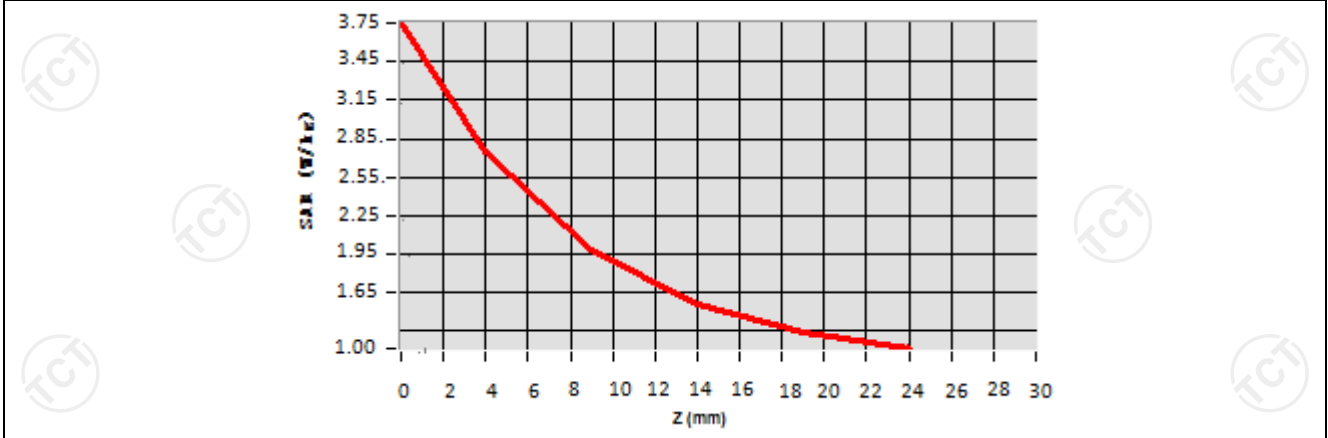

**Hot spot position**

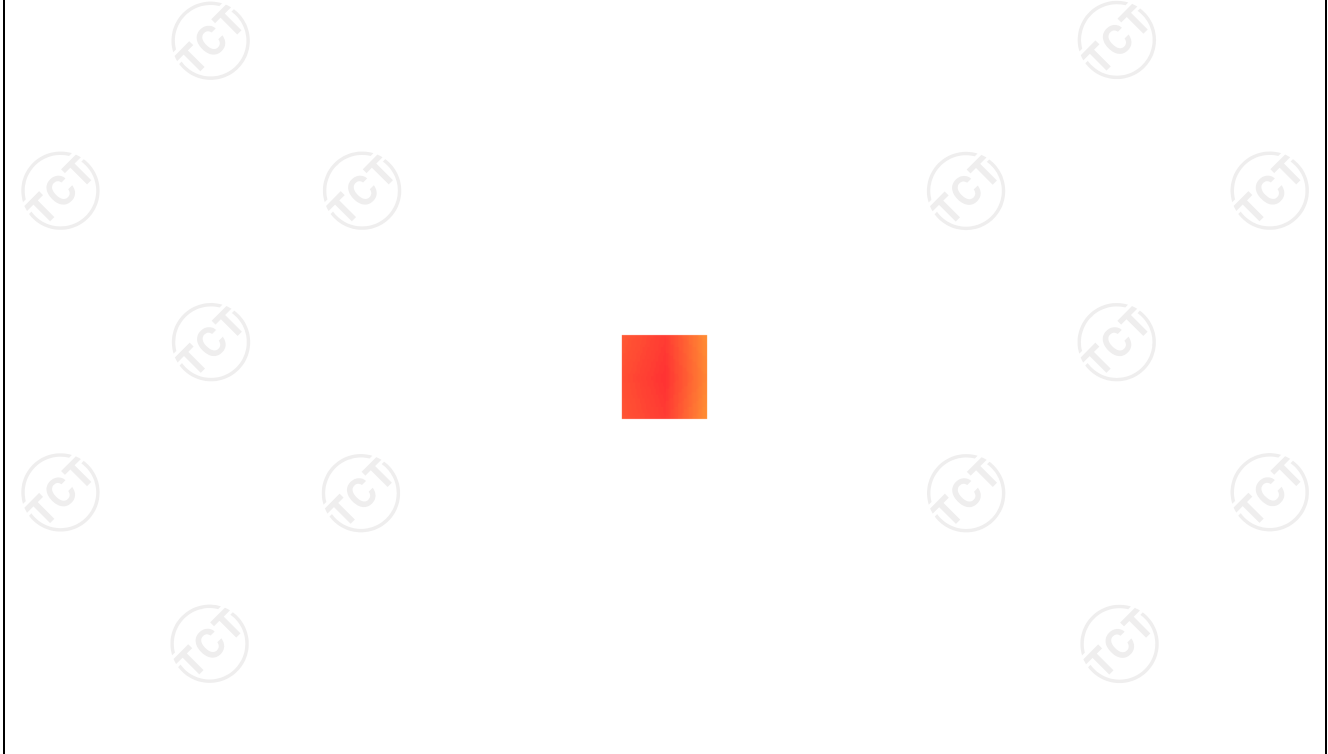

Date of measurement: 12/13/2021 Test mode: 2450MHz (Body)  
 Product Description: Validation  
 Dipole Model: SID2450  
 E-Field Probe: SSE2 (SN 36/20 EPGO346)

Phantom	Validation plane
Input Power	100mW
Crest Factor	1.0
Probe Conversion factor	2.37
Frequency (MHz)	2450.000000
Relative permittivity (real part)	54.616199
Relative permittivity (imaginary part)	14.930150
Conductivity (S/m)	2.012159
Variation (%)	-0.230000
<b>SAR 10g (W/Kg)</b>	<b>2.416669</b>
<b>SAR 1g (W/Kg)</b>	<b>5.066368</b>

**SURFACE SAR**

**VOLUME SAR**

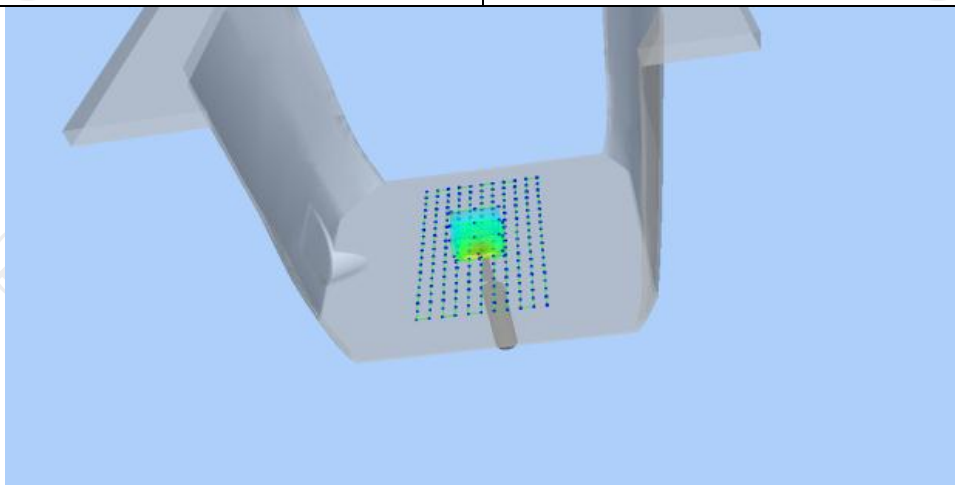
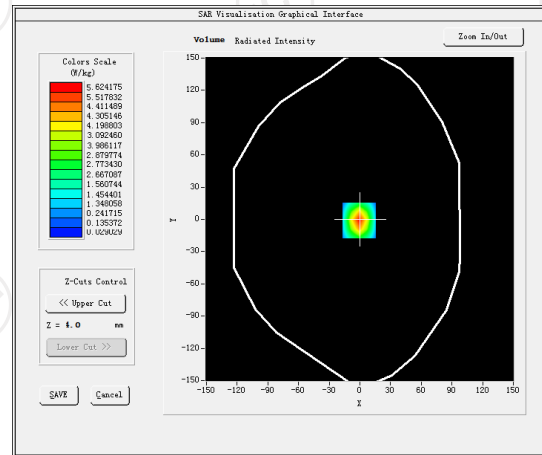
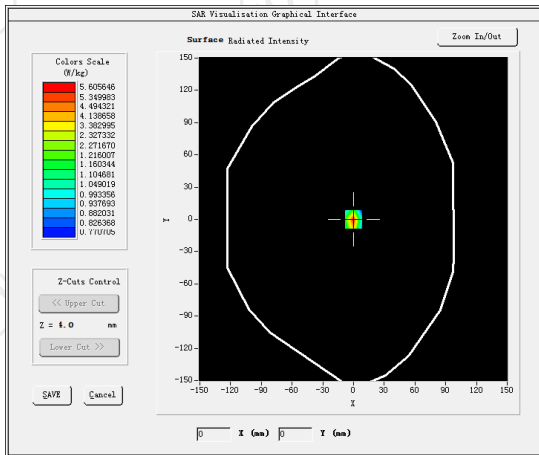

Z (mm)	0.00	4.00	9.00	14.00	19.00
SAR (W/Kg)	5.0622	2.7984	1.5251	0.8352	0.4200

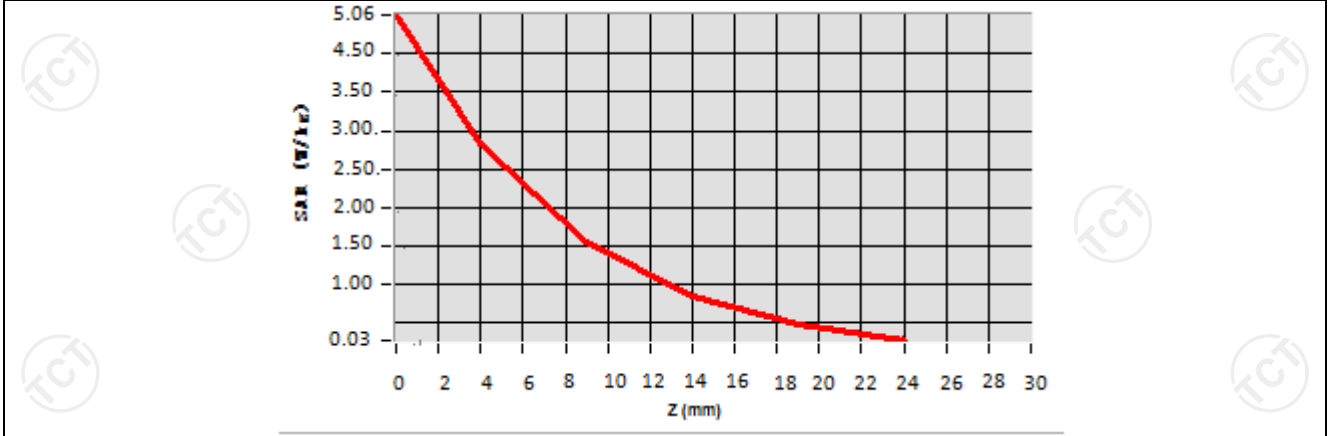

**Hot spot position**

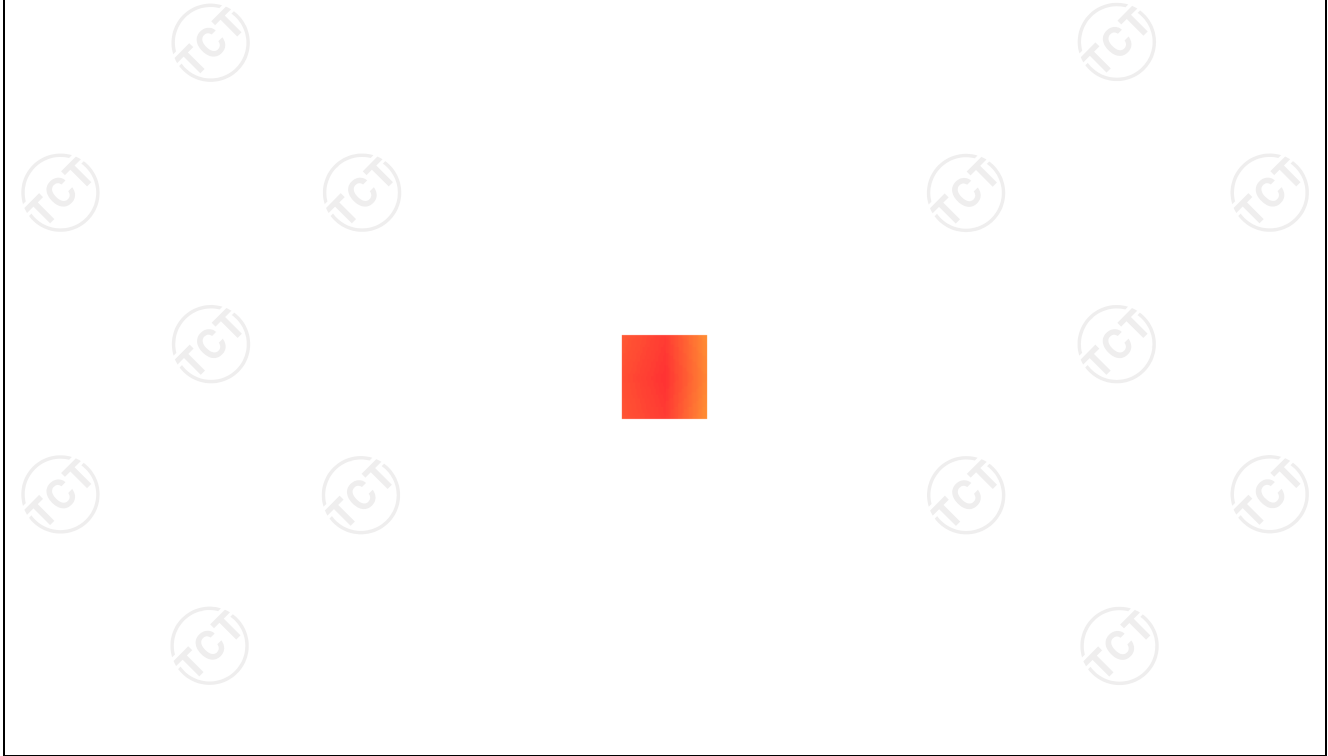

Date of measurement: 12/14/2021 Test mode: 5200 (Body)  
 Product Description: Validation  
 Dipole Model: SID5000  
 E-Field Probe: SSE2 (SN 36/20 EPGO346)

Phantom	Validation plane
Input Power	100mW
Crest Factor	1.0
Probe Conversion factor	2.08
Frequency (MHz)	5200.000000
Relative permittivity (real part)	49.022077
Relative permittivity (imaginary part)	21.378187
Conductivity (S/m)	5.458883
Variation (%)	-3.140000
<b>SAR 10g (W/Kg)</b>	<b>5.623123</b>
<b>SAR 1g (W/Kg)</b>	<b>16.349446</b>

**SURFACE SAR**

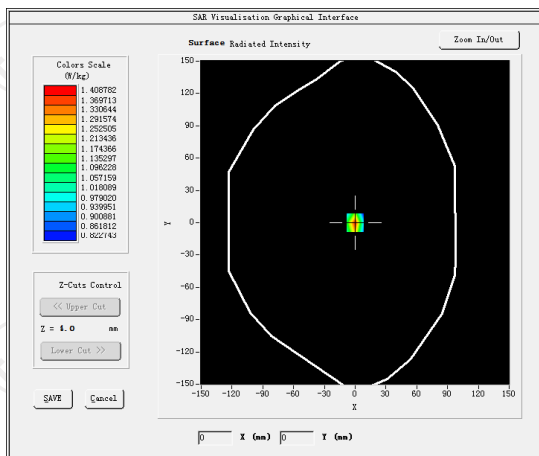

**VOLUME SAR**

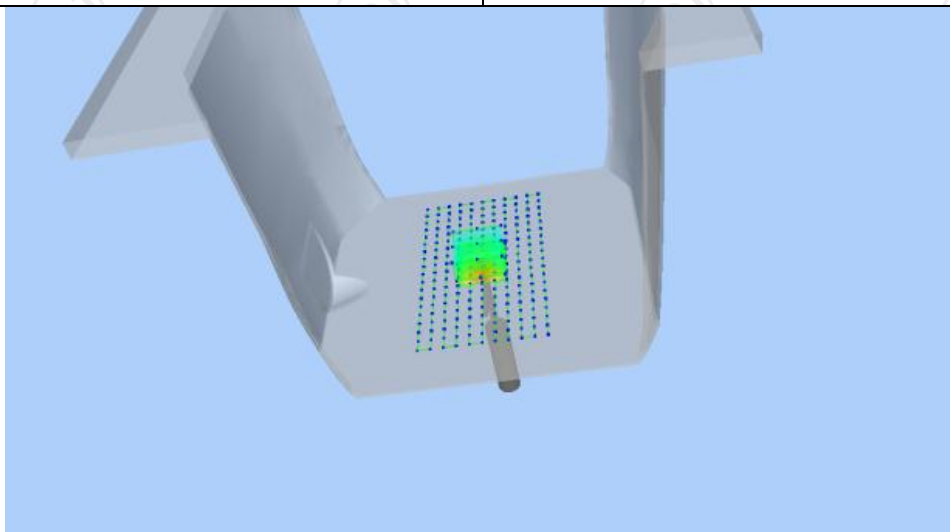
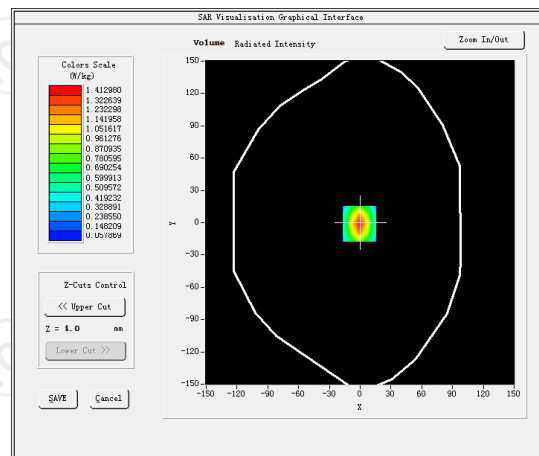



Z (mm)	0.00	4.00	9.00	14.00	19.00
SAR (W/Kg)	42.9525	27.6022	10.3594	10.2202	10.0725

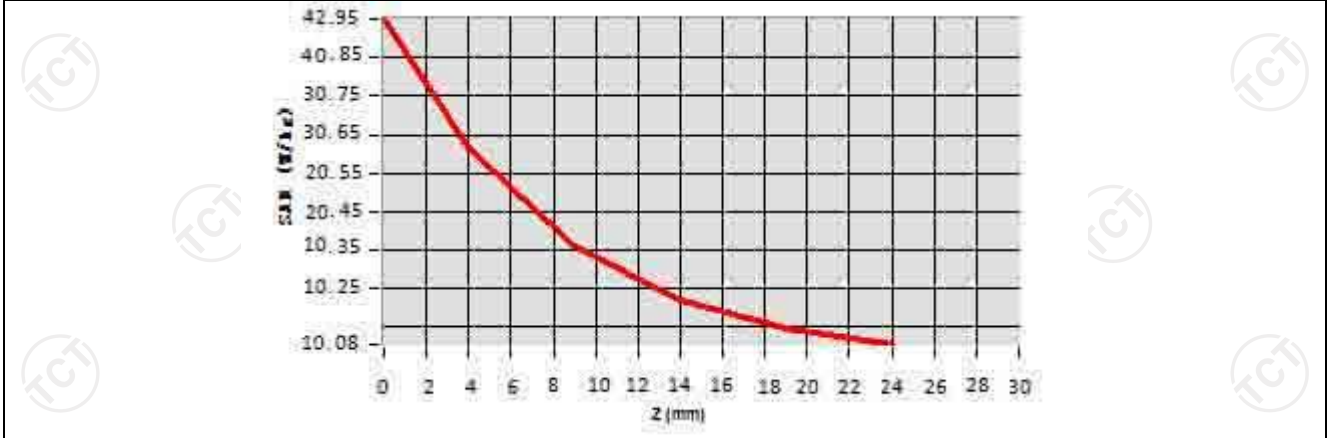

**Hot spot position**

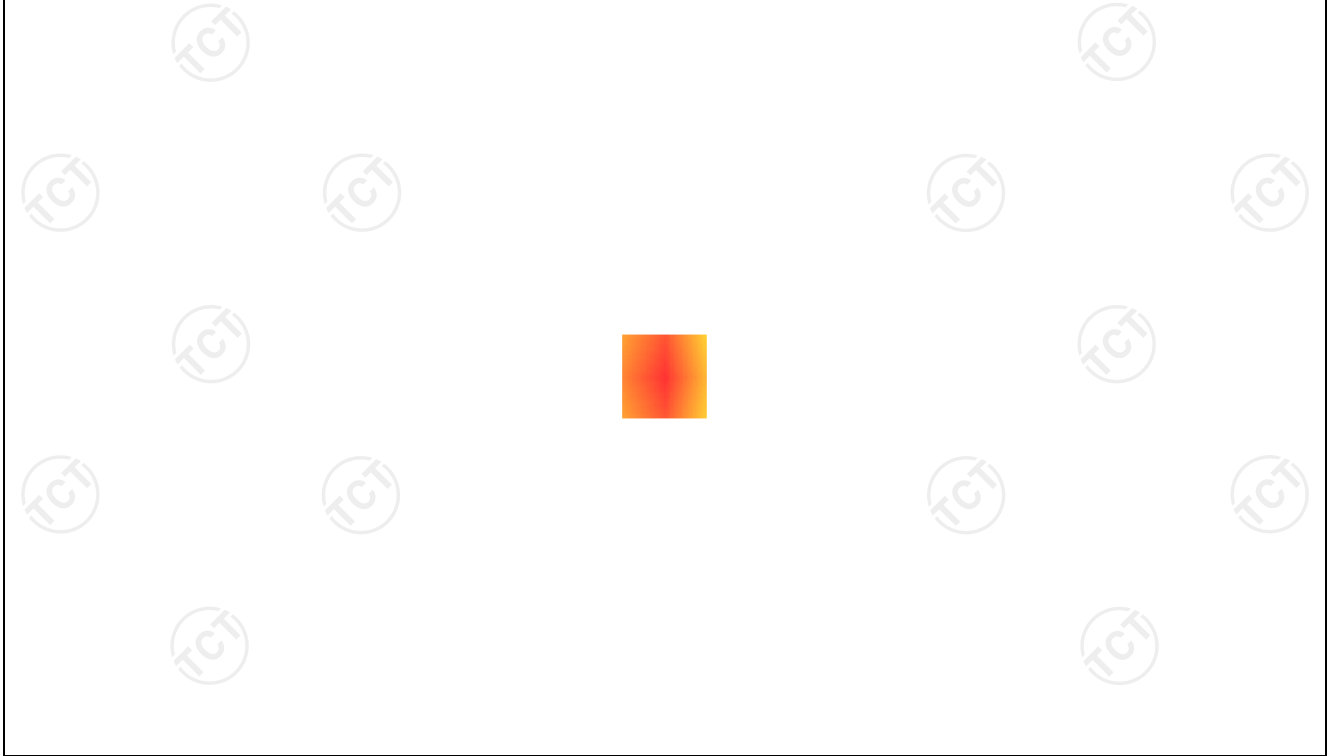

Date of measurement: 12/17/2021 Test mode: 5800MHz (Body)  
 Product Description: Validation  
 Dipole Model: SID5000  
 E-Field Probe: SSE2 (SN 36/20 EPGO346)

Phantom	Validation plane
Input Power	100mW
Crest Factor	1.0
Probe Conversion factor	2.13
Frequency (MHz)	5800.000000
Relative permittivity (real part)	47.813887
Relative permittivity (imaginary part)	14.935214
Conductivity (S/m)	6.124821
Variation (%)	-1.420000
<b>SAR 10g (W/Kg)</b>	<b>6.382177</b>
<b>SAR 1g (W/Kg)</b>	<b>18.365098</b>

**SURFACE SAR**

**VOLUME SAR**

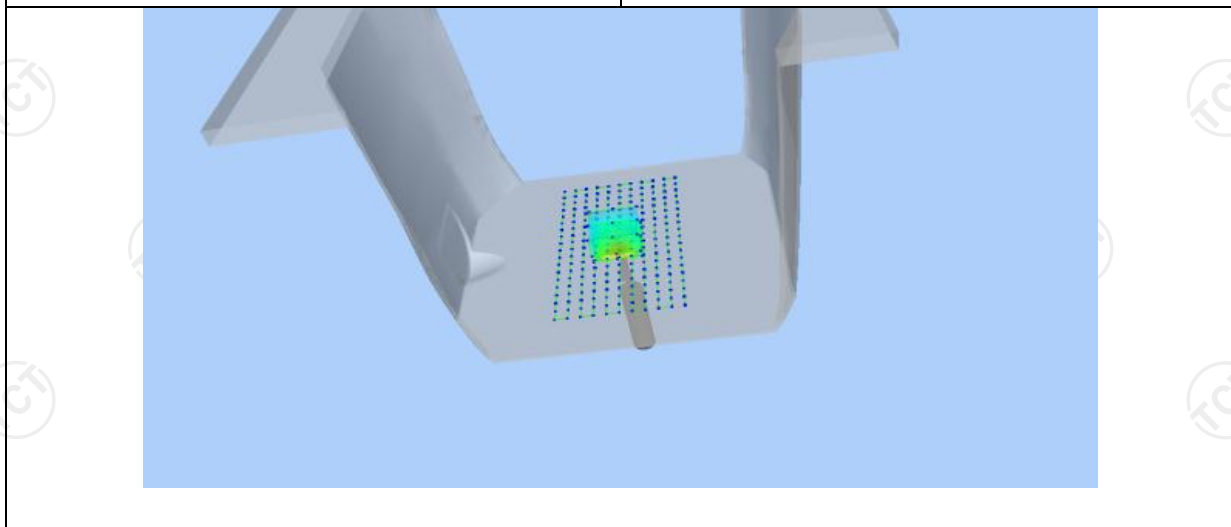
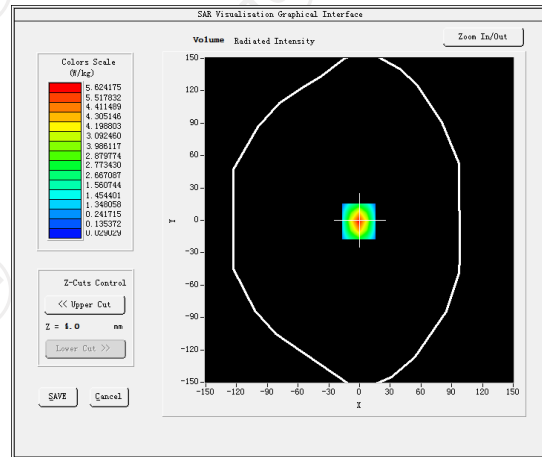
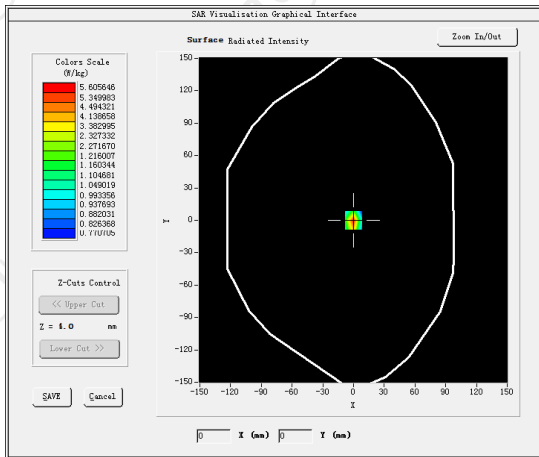

Z (mm)	0.00	4.00	9.00	14.00	19.00
SAR (W/Kg)	51.8021	29.9510	10.2037	10.0321	10.0203

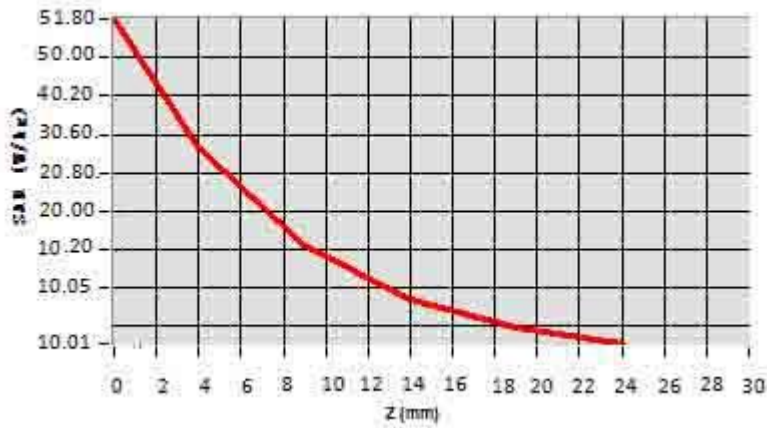

Hot spot position



## 12. SAR Test Data

GSM850

### MEASUREMENT 1

High Band SAR (Channel 251):

Date: 11/29/2021

<b>Frequency (MHz)</b>	848.800000
<b>Relative permittivity (real part)</b>	55.212927
<b>Relative permittivity (imaginary part)</b>	21.368266
<b>Conductivity (S/m)</b>	0.971230
<b>Variation (%)</b>	2.400000
<b>Crest Factor:</b>	1.0
<b>Probe Conversion factor</b>	1.78
<b>E-Field Probe:</b>	SSE2 (SN 36/20 EPGO346)
<b>Area Scan</b>	<u>dx=8mm dy=8mm, h= 5.00 mm</u>
<b>ZoomScan</b>	<u>5x5x7, dx=8mm dy=8mm</u> <u>dz=5mm, Complete/ndx=8mm dy=8mm, h=</u> <u>5.00 mm</u>
<b>Phantom</b>	<u>Validation plane</u>
<b>Device Position</b>	<u>Body back(10mm)</u>
<b>Band</b>	<u>GSM850(Voice)</u>

#### SURFACE SAR

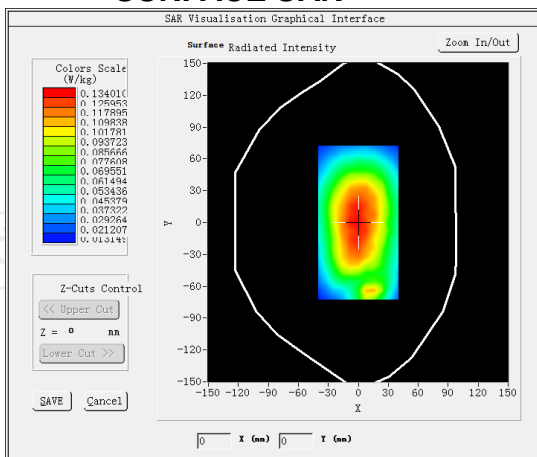

#### VOLUME SAR

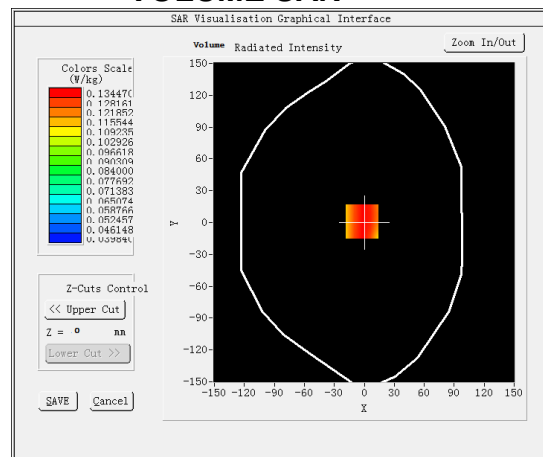

**Maximum location: X=-2.00, Y=1.00 SAR Peak: 0.17 W/kg**

**SAR 10g (W/Kg)**

0.192914

**SAR 1g (W/Kg)**

0.315770

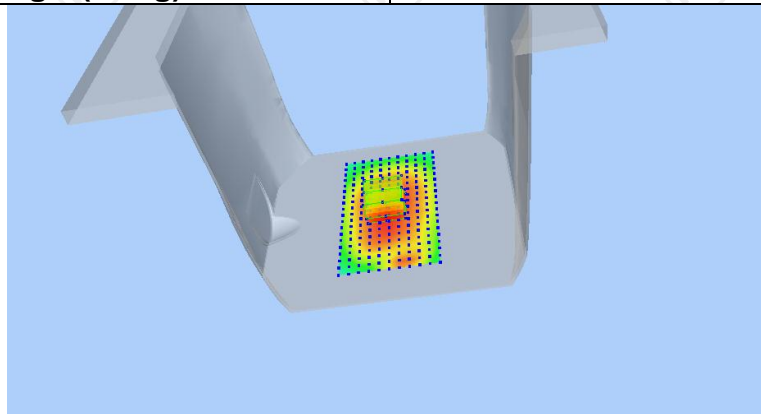

<b>Z (mm)</b>	<b>0.00</b>	<b>4.00</b>	<b>9.00</b>	<b>14.00</b>	<b>19.00</b>
<b>SAR (W/Kg)</b>	<b>0.4300</b>	<b>0.3357</b>	<b>0.2419</b>	<b>0.1707</b>	<b>0.1169</b>

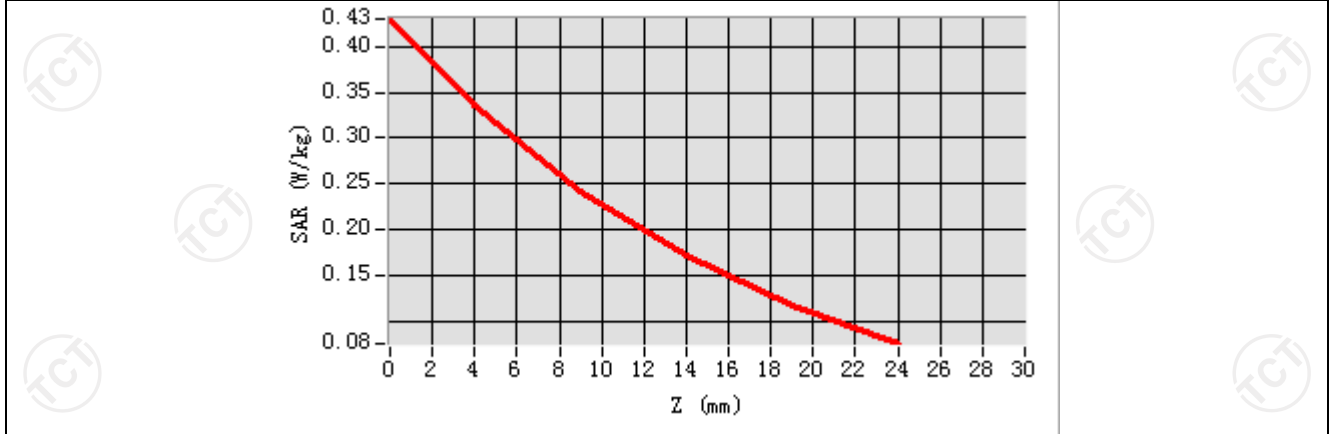

**Hot spot position**

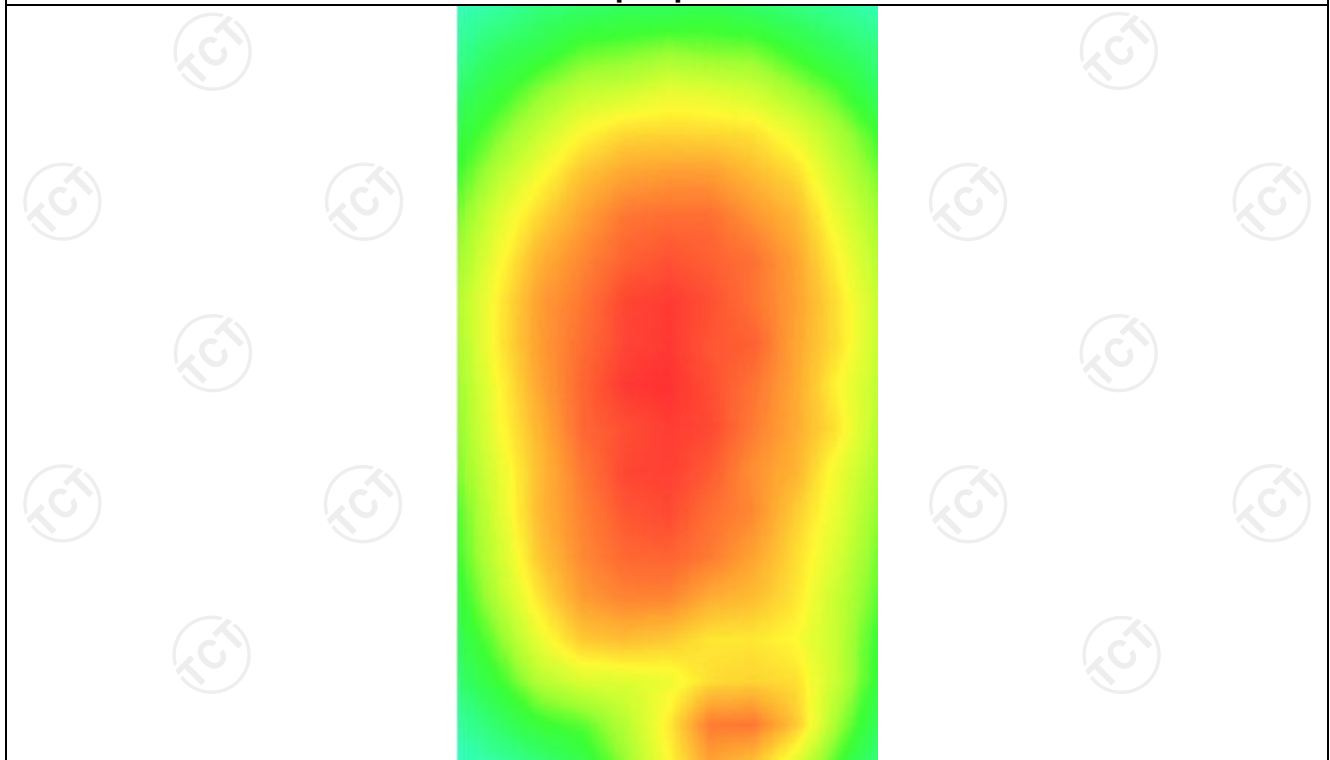

**MEASUREMENT 2**

Hight Band SAR (Channel 251):

Date: 11/29/2021

<b>Frequency (MHz)</b>	848.800000
<b>Relative permittivity (real part)</b>	55.212927
<b>Relative permittivity (imaginary part)</b>	21.368266
<b>Conductivity (S/m)</b>	0.971230
<b>Variation (%)</b>	1.840000
<b>Crest Factor:</b>	1.0
<b>Probe Conversion factor</b>	1.78
<b>E-Field Probe:</b>	SSE2 (SN 36/20 EPG0346)
<b>Area Scan</b>	<u>dx=8mm dy=8mm, h= 5.00 mm</u>
<b>ZoomScan</b>	<u>5x5x7,dx=8mm dy=8mm</u> <u>dz=5mm,Complete/ndx=8mm dy=8mm, h=</u> <u>5.00 mm</u>
<b>Phantom</b>	<u>Validation plane</u>
<b>Device Position</b>	<u>Body back(10mm)</u>
<b>Band</b>	<u>GSM850(GPRS 4slot)</u>

**SURFACE SAR**

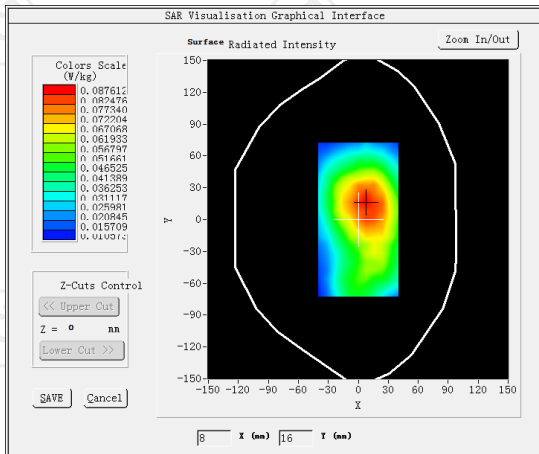

**VOLUME SAR**

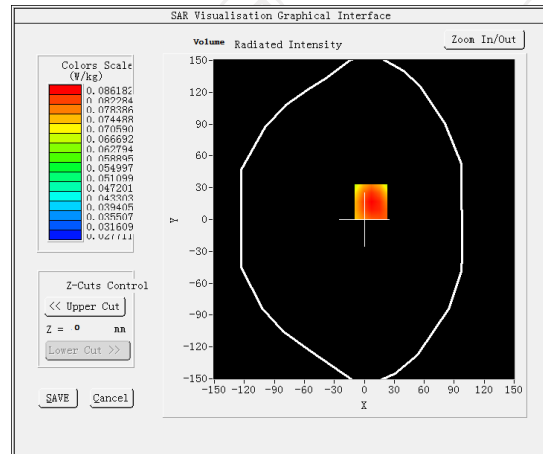

**Maximum location: X=7.00, Y=17.00 SAR Peak: 0.10 W/kg**

<b>SAR 10g (W/Kg)</b>	0.328419
<b>SAR 1g (W/Kg)</b>	0.623129

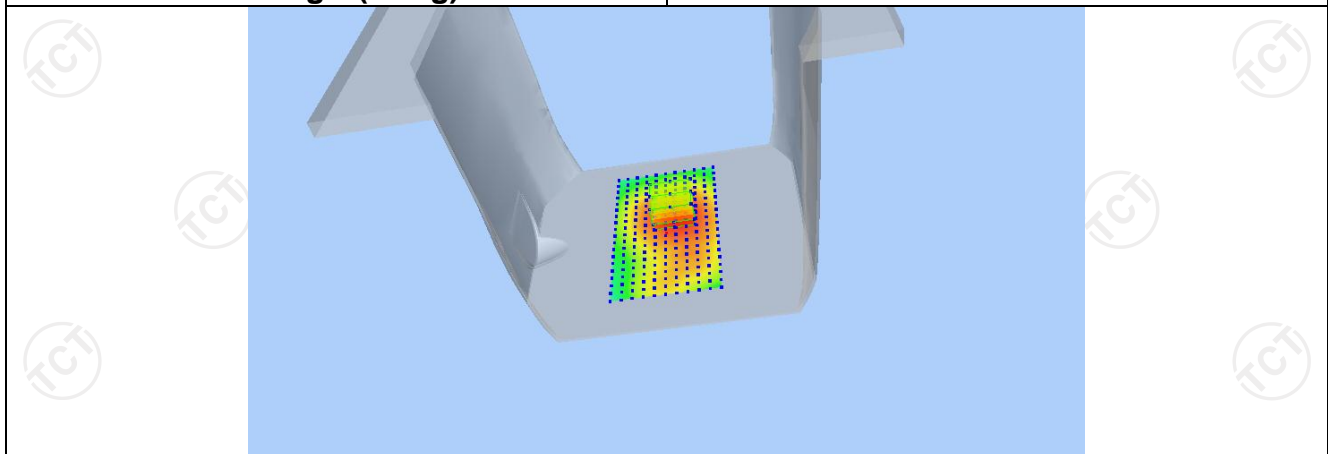

<b>Z (mm)</b>	<b>0.00</b>	<b>4.00</b>	<b>9.00</b>	<b>14.00</b>	<b>19.00</b>
<b>SAR (W/Kg)</b>	<b>1.1002</b>	<b>0.6857</b>	<b>0.3690</b>	<b>0.2009</b>	<b>0.1168</b>

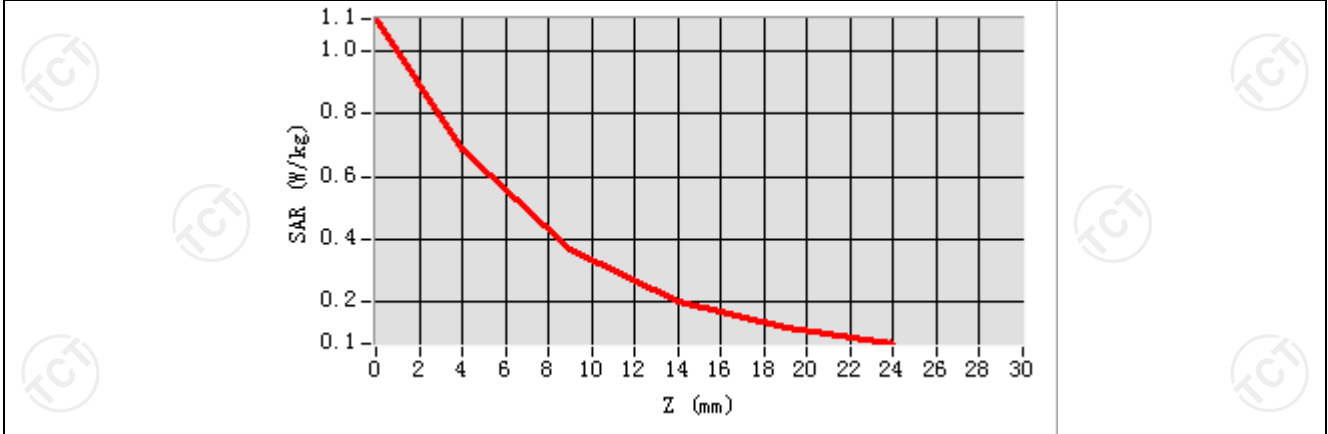

**Hot spot position**



**MEASUREMENT 3**

Hight Band SAR (Channel 251):

Date: 11/29/2021

<b>Frequency (MHz)</b>	848.800000
<b>Relative permittivity (real part)</b>	55.212927
<b>Relative permittivity (imaginary part)</b>	21.378266
<b>Conductivity (S/m)</b>	0.971230
<b>Variation (%)</b>	3.980000
<b>Crest Factor:</b>	1.0
<b>Probe Conversion factor</b>	1.78
<b>E-Field Probe:</b>	SSE2 (SN 36/20 EPG0346)
<b>Area Scan</b>	<u>dx=8mm dy=8mm, h= 5.00 mm</u>
<b>ZoomScan</b>	<u>5x5x7,dx=8mm dy=8mm</u> <u>dz=5mm,Complete/ndx=8mm dy=8mm, h=</u> <u>5.00 mm</u>
<b>Phantom</b>	<u>Validation plane</u>
<b>Device Position</b>	<u>Body back(10mm)</u>
<b>Band</b>	<u>GSM850(GPRS 4slot hotspot)</u>

**SURFACE SAR**

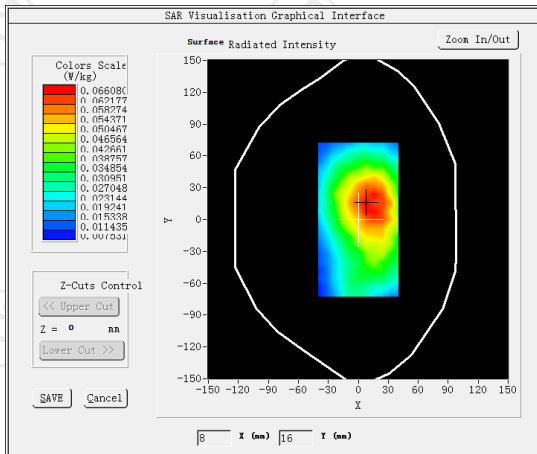

**VOLUME SAR**

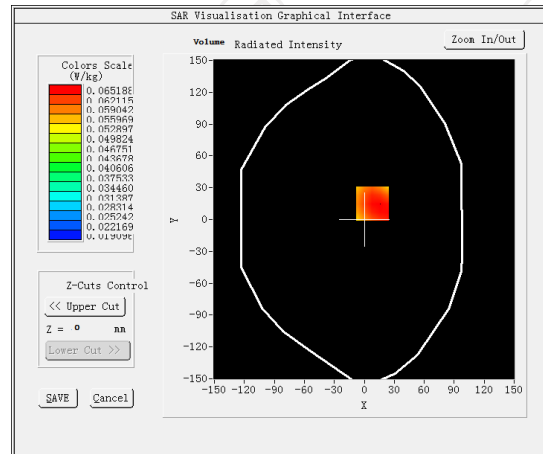

**Maximum location: X=-10.00, Y=-33.00 SAR Peak: 1.23 W/kg**

**SAR 10g (W/Kg)**

0.337694

**SAR 1g (W/Kg)**

0.642629

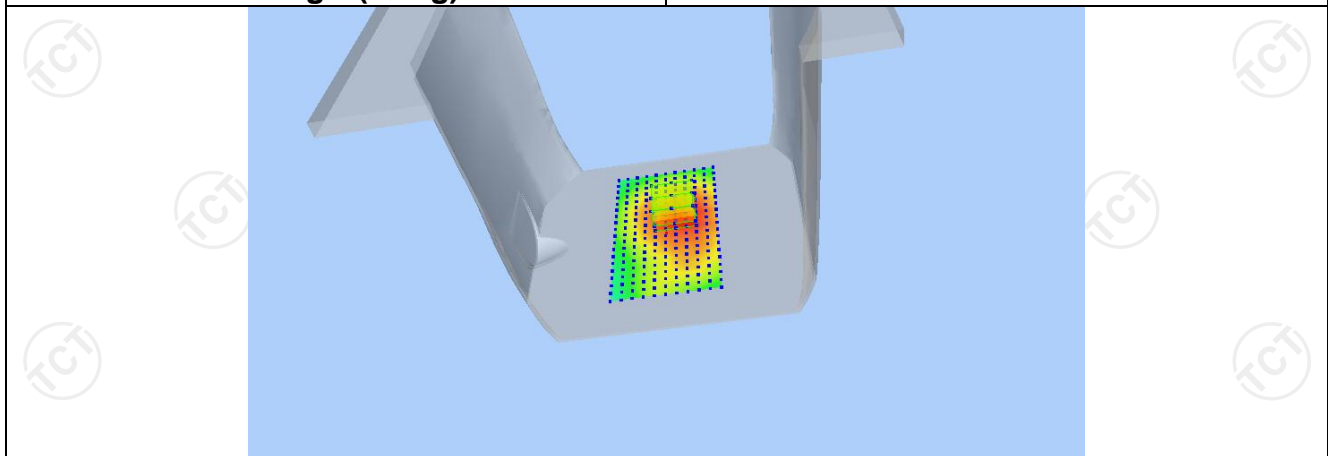



<b>Z (mm)</b>	<b>0.00</b>	<b>4.00</b>	<b>9.00</b>	<b>14.00</b>	<b>19.00</b>
<b>SAR (W/Kg)</b>	<b>1.2058</b>	<b>0.7195</b>	<b>0.3640</b>	<b>0.1881</b>	<b>0.1080</b>

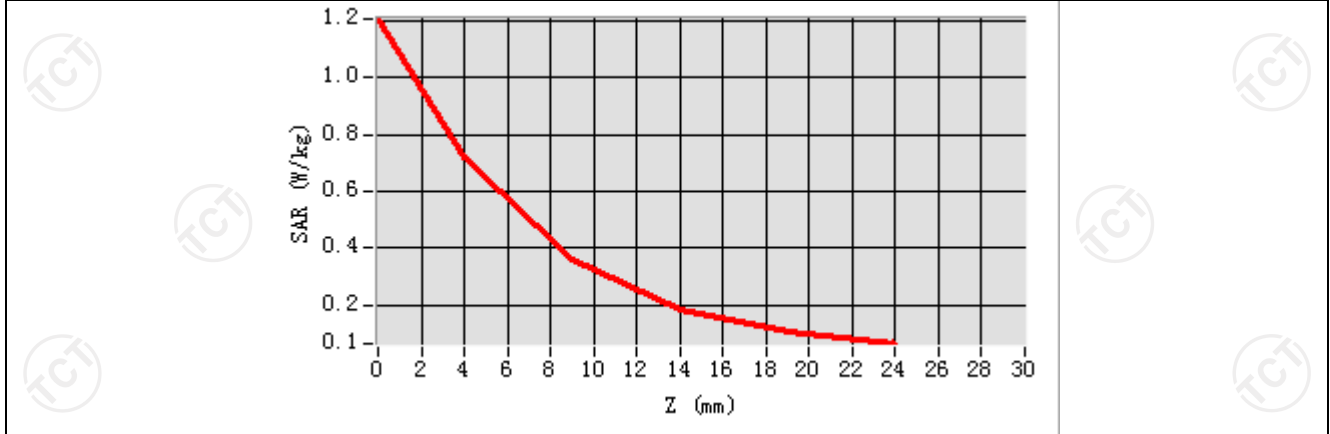

**Hot spot position**

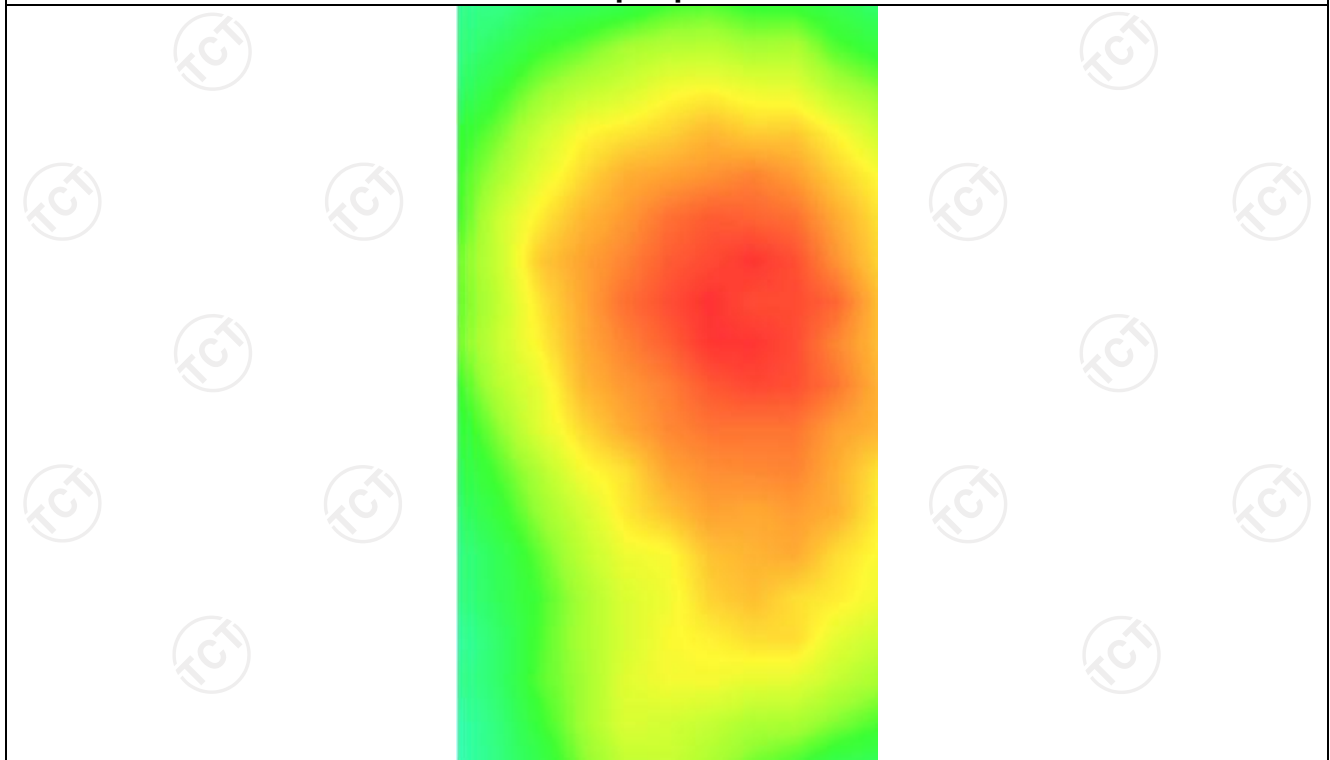

GSM1900

**MEASUREMENT 1**

Lower Band SAR (Channel 512):

Date: 12/07/2021

<b>Frequency (MHz)</b>	1850.200000
<b>Relative permittivity (real part)</b>	53.341337
<b>Relative permittivity (imaginary part)</b>	14.322400
<b>Conductivity (S/m)</b>	1.491736
<b>Variation (%)</b>	-0.730000
<b>Crest Factor</b>	1.0
<b>Probe Conversion factor</b>	2.16
<b>E-Field Probe:</b>	SSE2 (SN 36/20 EPG0346)
<b>Area Scan</b>	<u>dx=8mm dy=8mm, h= 5.00 mm</u>
<b>ZoomScan</b>	<u>5x5x7, dx=8mm dy=8mm</u> <u>dz=5mm, Complete/ndx=8mm dy=8mm, h=</u> <u>5.00 mm</u>
<b>Phantom</b>	<u>Validation plane</u>
<b>Device Position</b>	<u>Body back(10mm)</u>
<b>Band</b>	<u>GSM1900(voice)</u>

**SURFACE SAR**

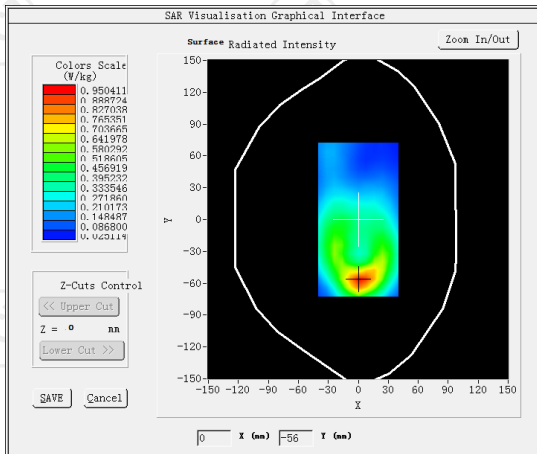

**VOLUME SAR**

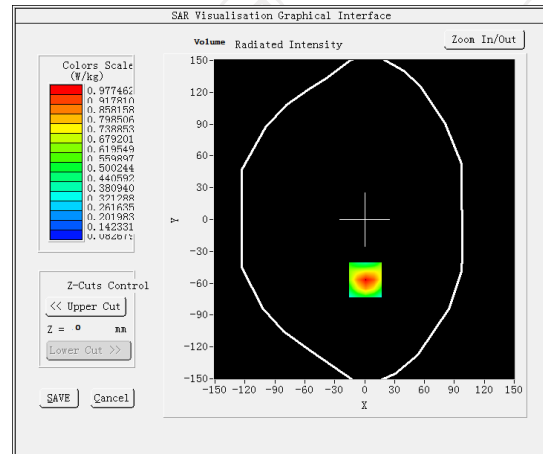

**Maximum location: X=1.00, Y=-57.00 SAR Peak: 1.49 W/kg**

**SAR 10g (W/Kg)**

0.145589

**SAR 1g (W/Kg)**

0.320076

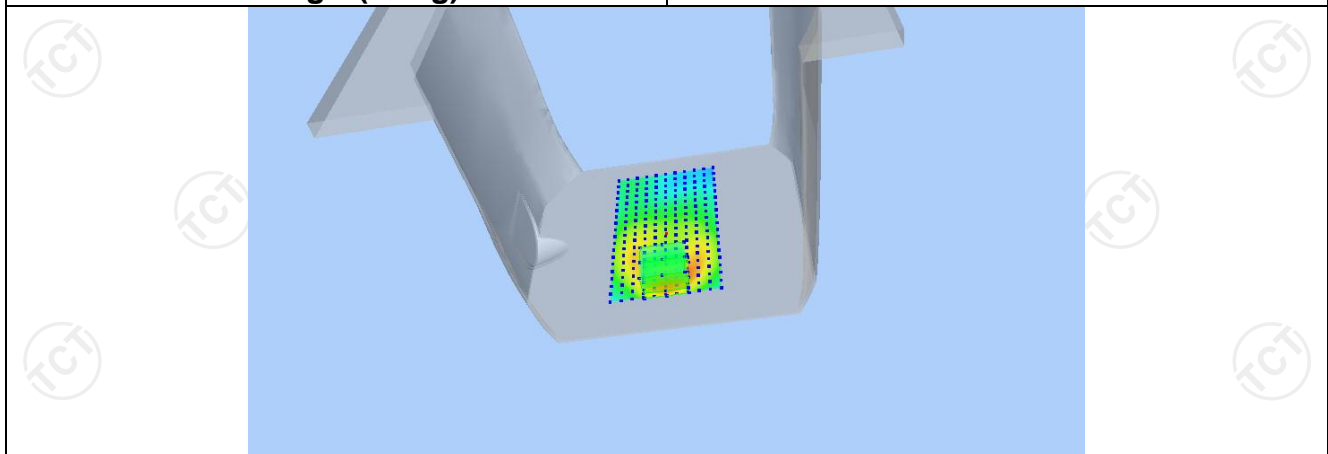

Z (mm)	0.00	4.00	9.00	14.00	19.00
SAR (W/Kg)	0.3941	0.2663	0.1681	0.0960	0.0592

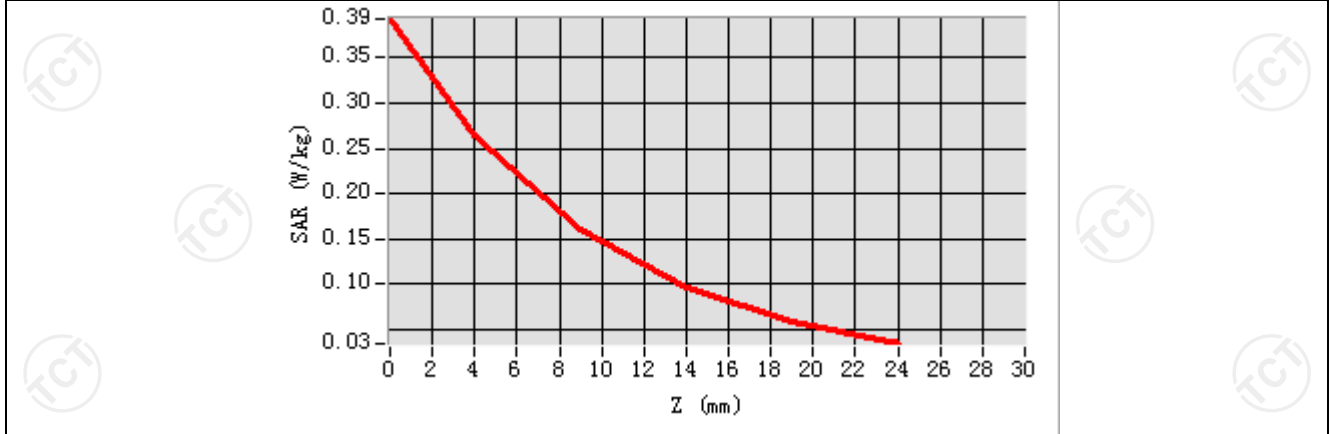

Hot spot position

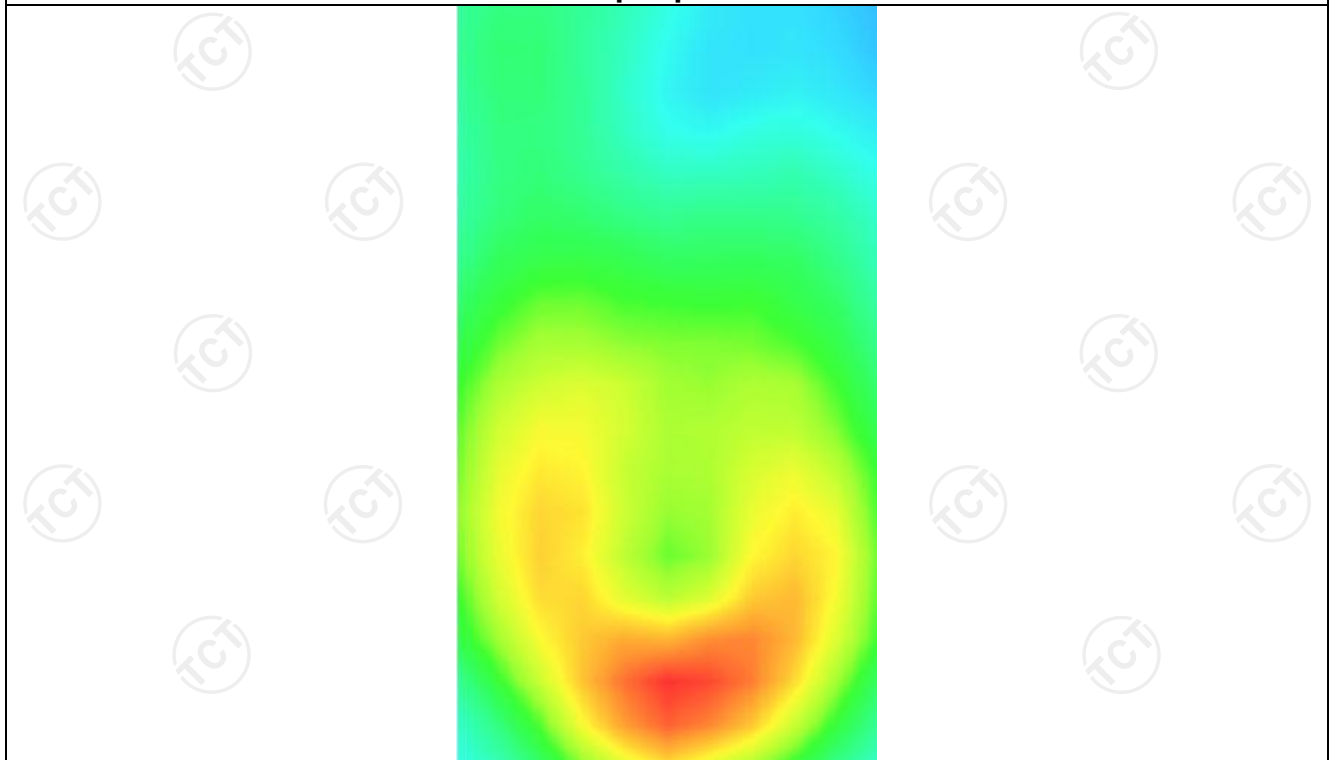

**MEASUREMENT 2**

Hight Band SAR (Channel 810):

Date: 12/07/2021

<b>Frequency (MHz)</b>	1909.800000
<b>Relative permittivity (real part)</b>	53.291337
<b>Relative permittivity (imaginary part)</b>	14.322400
<b>Conductivity (S/m)</b>	1.531736
<b>Variation (%)</b>	0.480000
<b>Crest Factor</b>	1.0
<b>Probe Conversion factor</b>	2.16
<b>E-Field Probe:</b>	SSE2 (SN 36/20 EPG0346)
<b>Area Scan</b>	<u>dx=8mm dy=8mm, h= 5.00 mm</u>
<b>ZoomScan</b>	<u>5x5x7,dx=8mm dy=8mm</u> <u>dz=5mm,Complete/ndx=8mm dy=8mm, h=</u> <u>5.00 mm</u>
<b>Phantom</b>	<u>Validation plane</u>
<b>Device Position</b>	<u>Body back(10mm)</u>
<b>Band</b>	<u>GSM1900(GPRS 4slot)</u>

**SURFACE SAR**

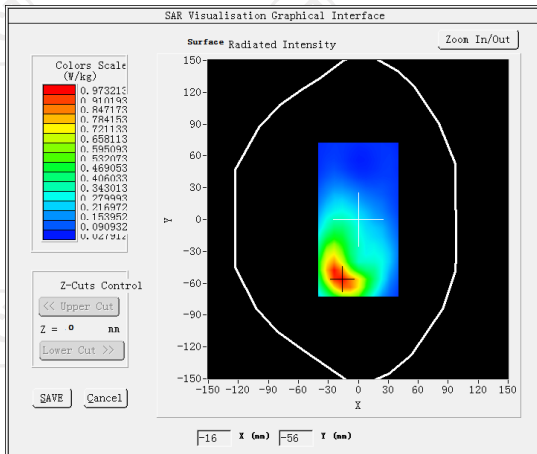

**VOLUME SAR**

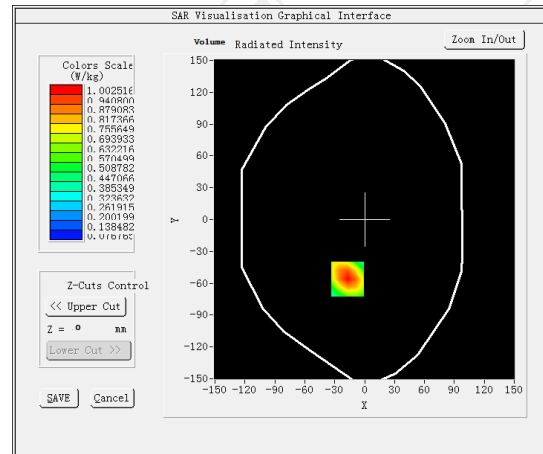

**Maximum location: X=-17.00, Y=-56.00 SAR Peak: 1.58 W/kg**

**SAR 10g (W/Kg)**

0.303660

**SAR 1g (W/Kg)**

0.524967

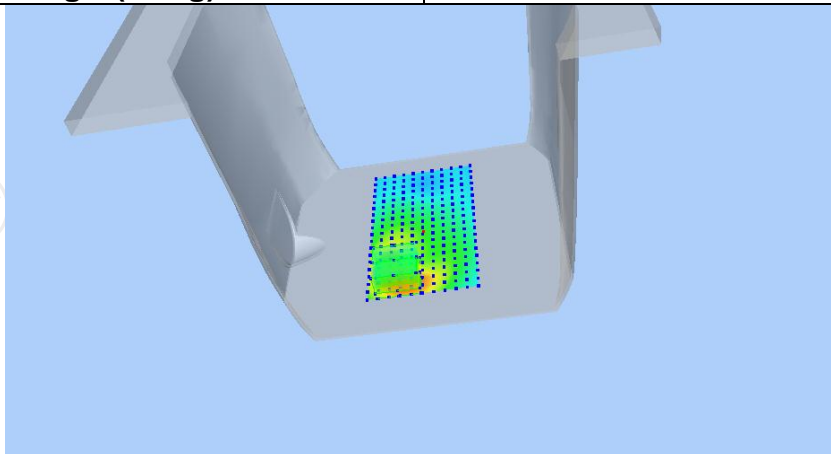

Z (mm)	0.00	4.00	9.00	14.00	19.00
SAR (W/Kg)	0.8473	0.5679	0.3373	0.1999	0.1205

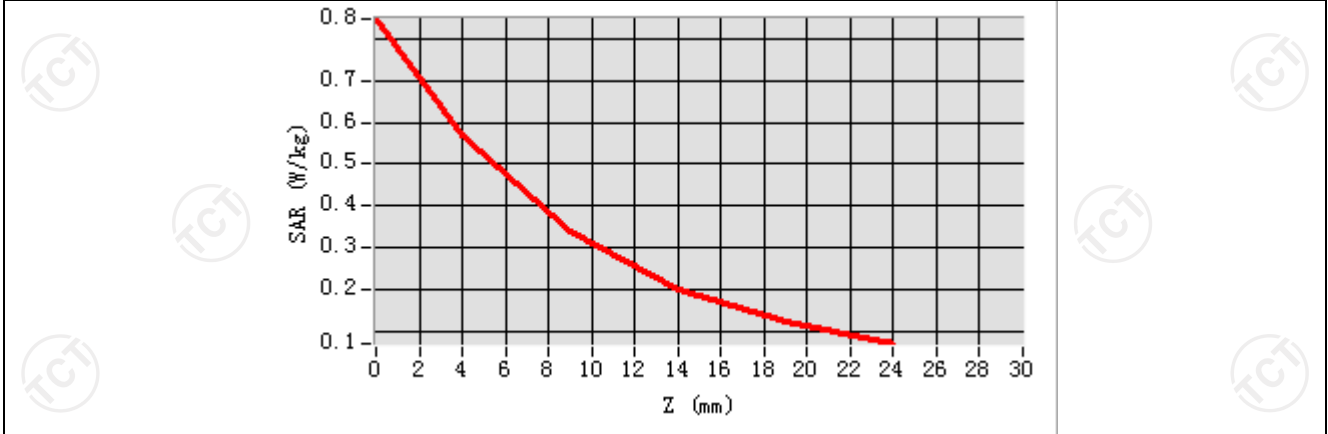

Hot spot position

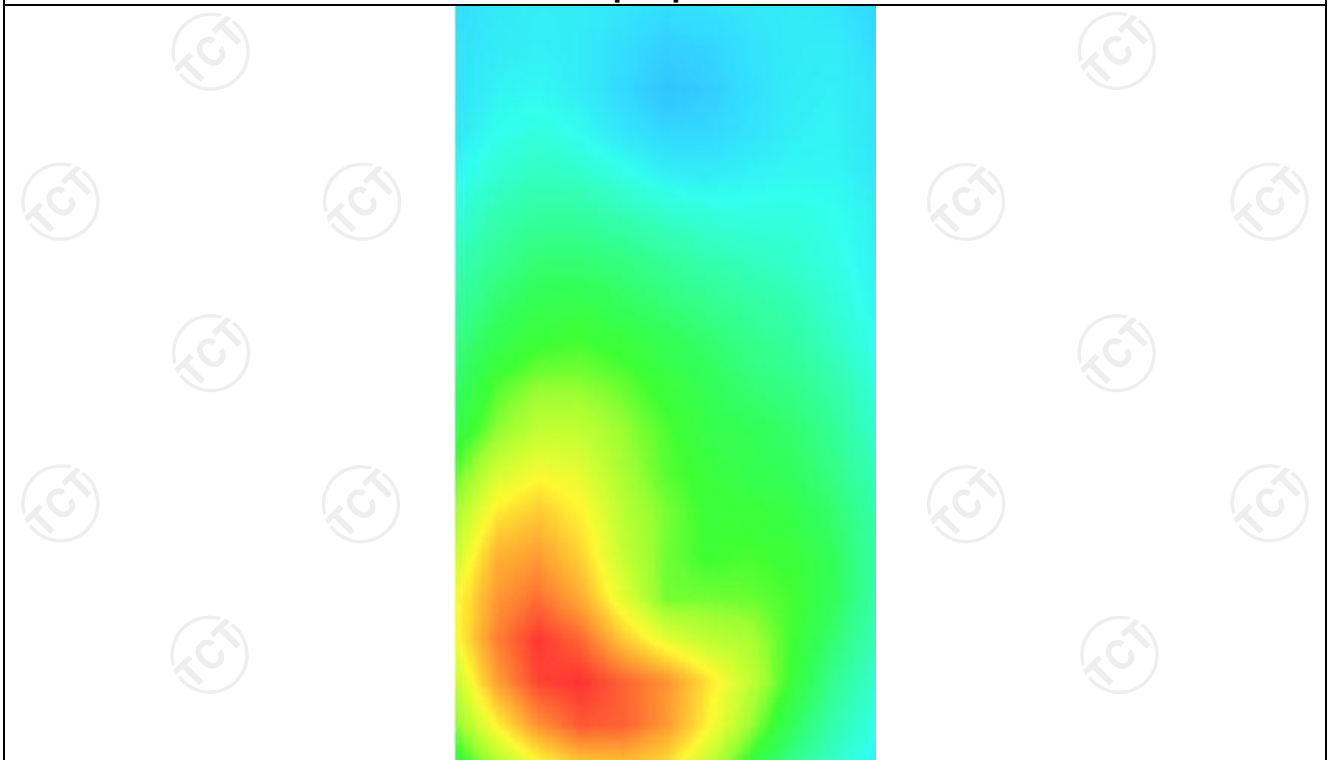

**MEASUREMENT 3**

Hight Band SAR (Channel 810):

Date: 12/07/2021

<b>Frequency (MHz)</b>	1909.800000
<b>Relative permittivity (real part)</b>	53.291337
<b>Relative permittivity (imaginary part)</b>	14.322400
<b>Conductivity (S/m)</b>	1.531736
<b>Variation (%)</b>	1.060000
<b>Crest Factor</b>	1.0
<b>Probe Conversion factor</b>	2.16
<b>E-Field Probe:</b>	SSE2 (SN 36/20 EPG0346)
<b>Area Scan</b>	<u>dx=8mm dy=8mm, h= 5.00 mm</u>
<b>ZoomScan</b>	<u>5x5x7,dx=8mm dy=8mm</u> <u>dz=5mm,Complete/ndx=8mm dy=8mm, h=</u> <u>5.00 mm</u>
<b>Phantom</b>	<u>Validation plane</u>
<b>Device Position</b>	<u>Body back(10mm)</u>
<b>Band</b>	<u>GSM1900(GPRS 4slot hotspot)</u>

**SURFACE SAR**

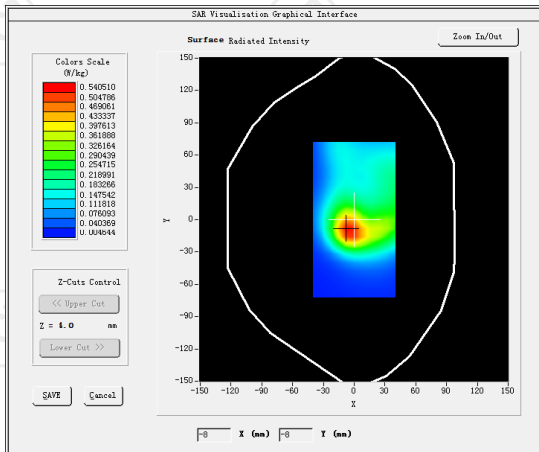

**VOLUME SAR**

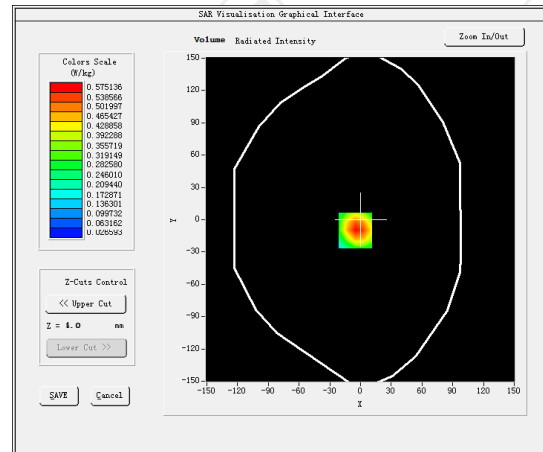

**Maximum location: X=-5.00, Y=-10.00 SAR Peak: 0.87 W/kg**

**SAR 10g (W/Kg)**

0.308172

**SAR 1g (W/Kg)**

0.543292

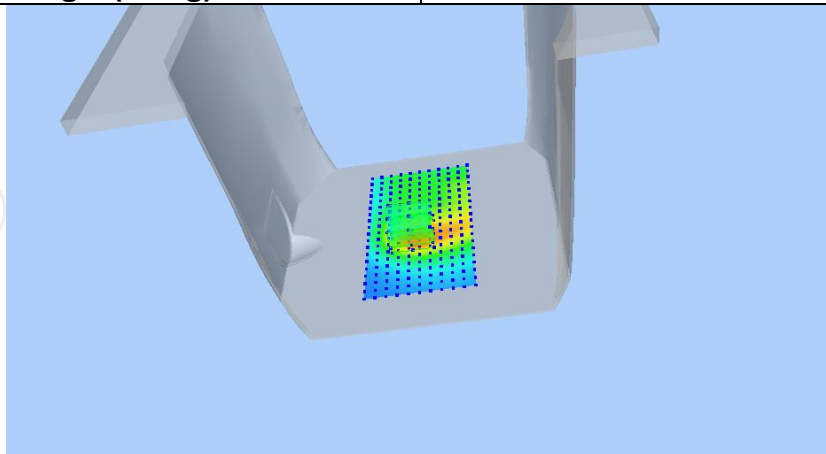

Z (mm)	0.00	4.00	9.00	14.00	19.00
SAR (W/Kg)	0.8581	0.5751	0.3415	0.2023	0.1218

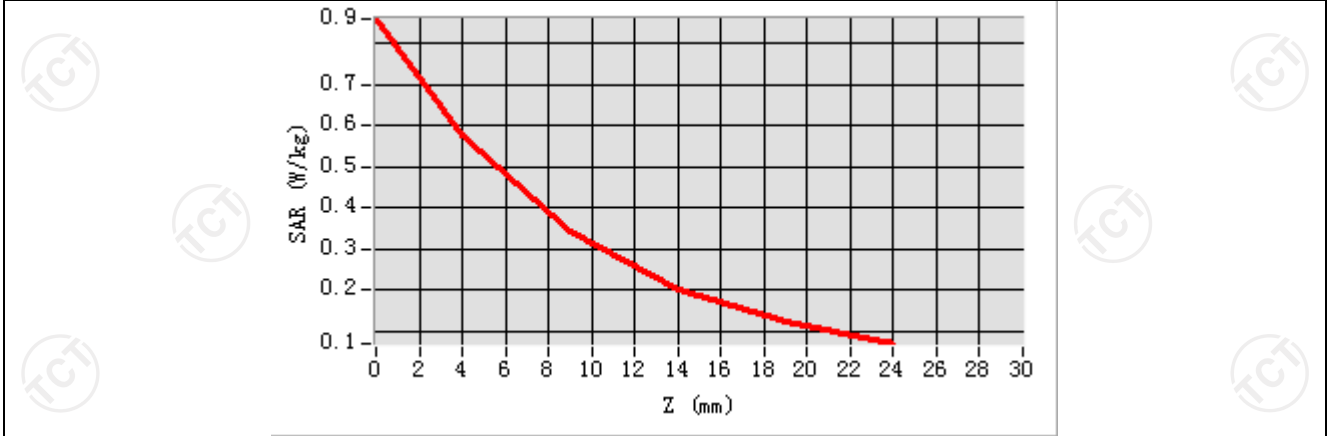

Hot spot position

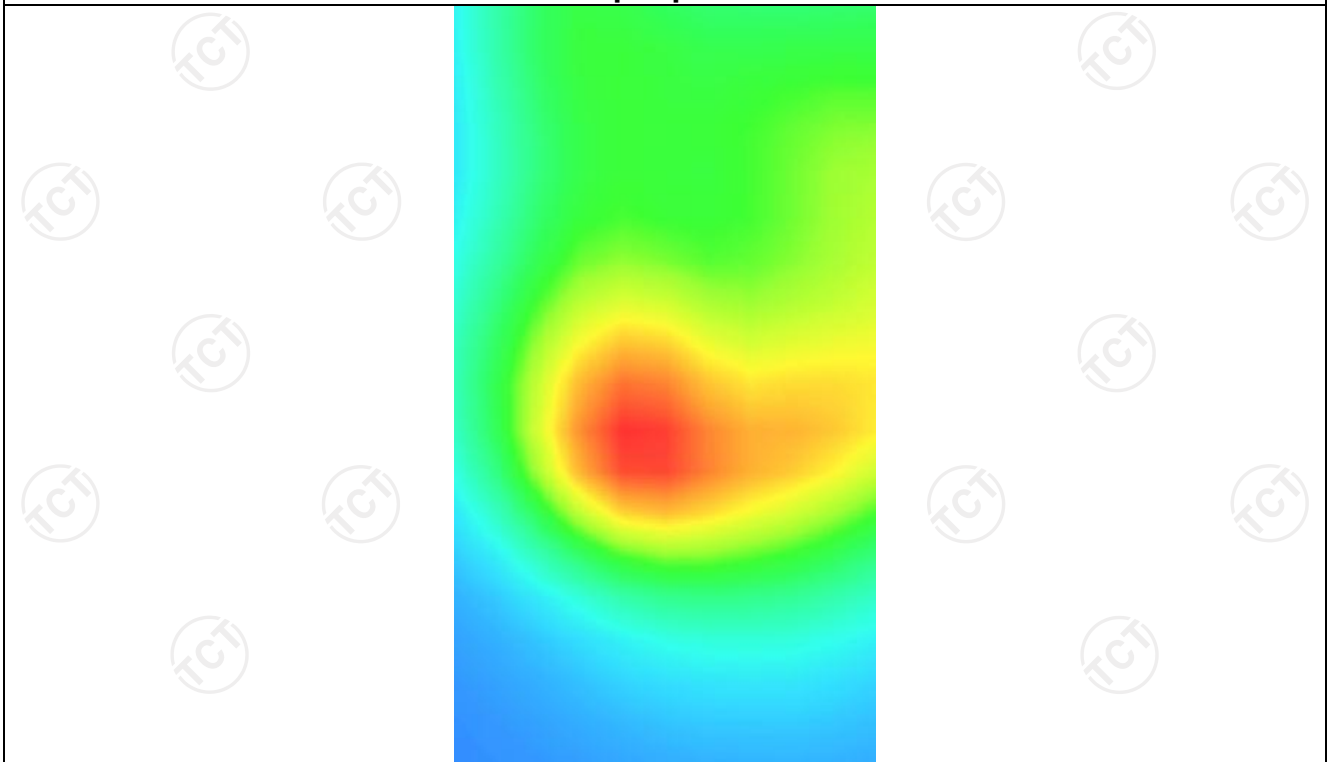

WCDMA Band II  
**MEASUREMENT 1**

Hight Band SAR (Channel 9538):

Date: 12/07/2021

<b>Frequency (MHz)</b>	1907.600000
<b>Relative permittivity (real part)</b>	53.291337
<b>Relative permittivity (imaginary part)</b>	14.232400
<b>Conductivity (S/m)</b>	1.526736
<b>Variation (%)</b>	-0.050000
<b>Crest Factor</b>	1.0
<b>Probe Conversion factor</b>	2.16
<b>E-Field Probe:</b>	SSE2 (SN 36/20 EPGO346)
<b>Area Scan</b>	<u>dx=8mm dy=8mm, h= 5.00 mm</u>
<b>ZoomScan</b>	<u>5x5x7, dx=8mm dy=8mm</u> <u>dz=5mm, Complete/ndx=8mm dy=8mm, h=</u> <u>5.00 mm</u>
<b>Phantom</b>	<u>Validation plane</u>
<b>Device Position</b>	<u>Body back(10mm)</u>
<b>Band</b>	<u>BAND1_WCDMA2100</u>

**SURFACE SAR**

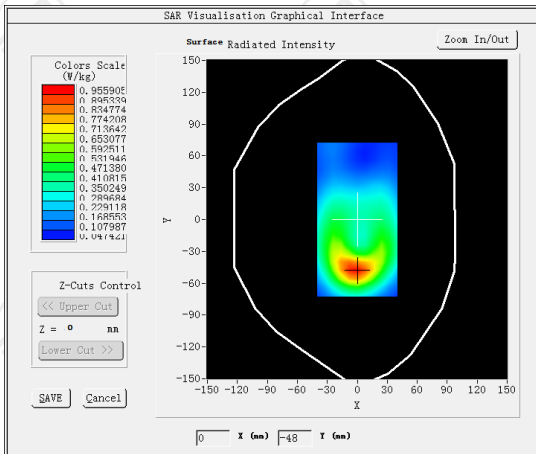

**VOLUME SAR**

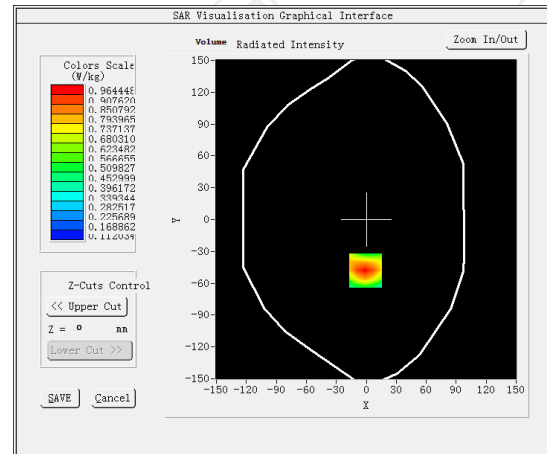

**Maximum location: X=-1.00, Y=-48.00 SAR Peak: 1.38 W/kg**

**SAR 10g (W/Kg)**

0.294218

**SAR 1g (W/Kg)**

0.618497

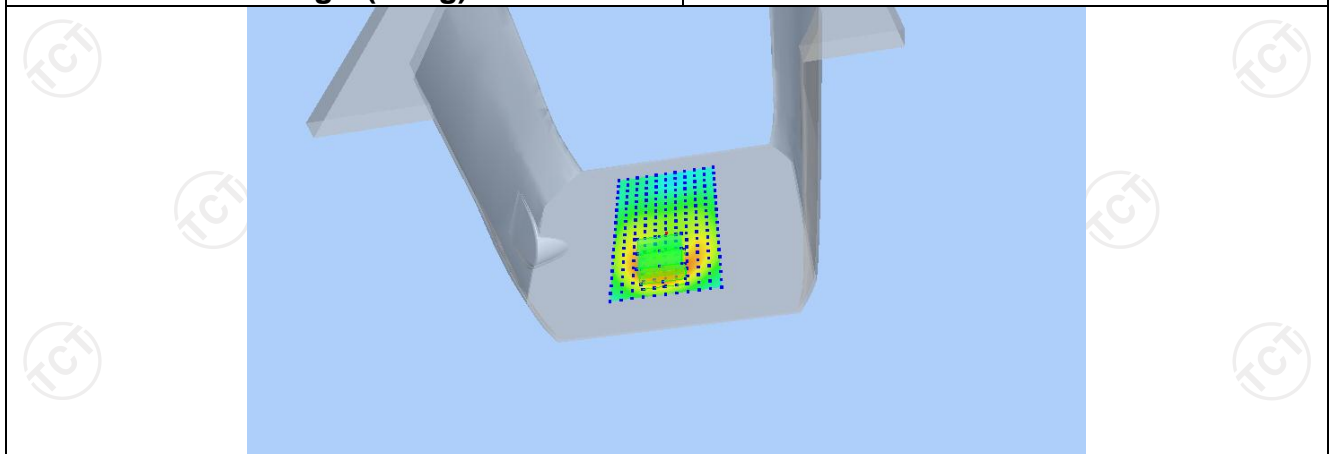



<b>Z (mm)</b>	<b>0.00</b>	<b>4.00</b>	<b>9.00</b>	<b>14.00</b>	<b>19.00</b>
<b>SAR (W/Kg)</b>	<b>0.8301</b>	<b>0.5529</b>	<b>0.3259</b>	<b>0.1923</b>	<b>0.1160</b>

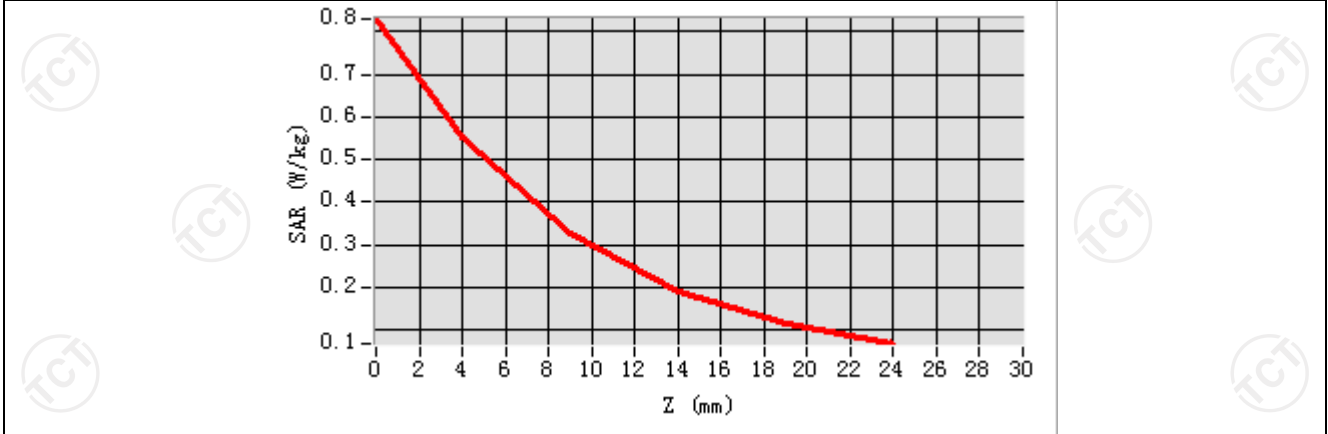

**Hot spot position**

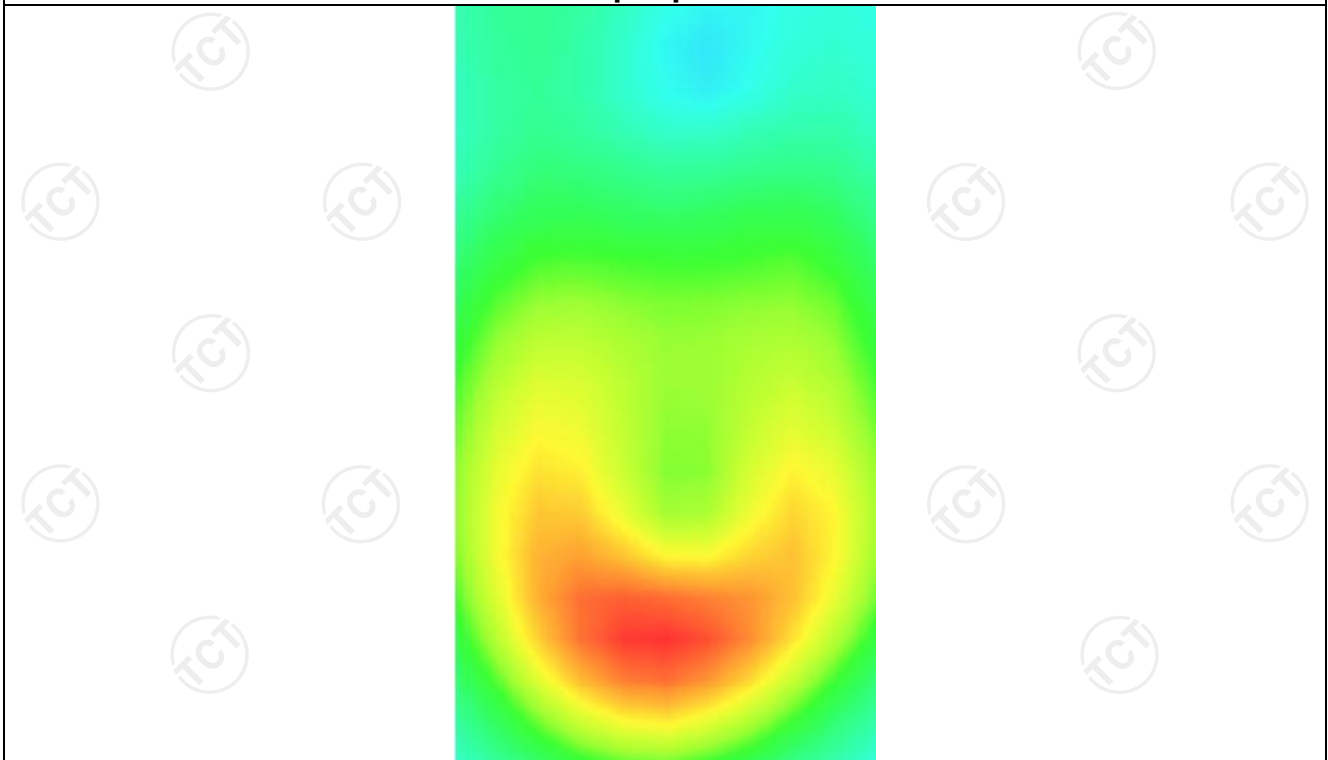

**MEASUREMENT 2**

Hight Band SAR (Channel 9538):

Date: 12/07/2021

<b>Frequency (MHz)</b>	1907.600000
<b>Relative permittivity (real part)</b>	53.291337
<b>Relative permittivity (imaginary part)</b>	14.232400
<b>Conductivity (S/m)</b>	1.526736
<b>Variation (%)</b>	-1.100000
<b>Crest Factor</b>	1.0
<b>Probe Conversion factor</b>	2.16
<b>E-Field Probe:</b>	SSE2 (SN 36/20 EPGO346)
<b>Area Scan</b>	<u>dx=8mm dy=8mm, h= 5.00 mm</u>
<b>ZoomScan</b>	<u>5x5x7, dx=8mm dy=8mm</u> <u>dz=5mm, Complete/ndx=8mm dy=8mm, h=</u> <u>5.00 mm</u>
<b>Phantom</b>	<u>Validation plane</u>
<b>Device Position</b>	<u>Body back(10mm)</u>
<b>Band</b>	<u>BAND1_WCDMA2100(hotspot)</u>

**SURFACE SAR**

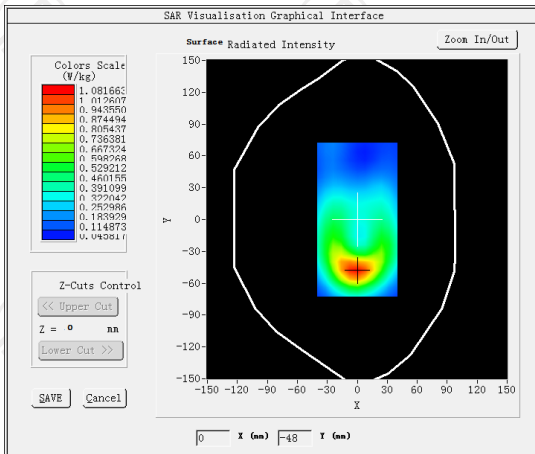

**VOLUME SAR**

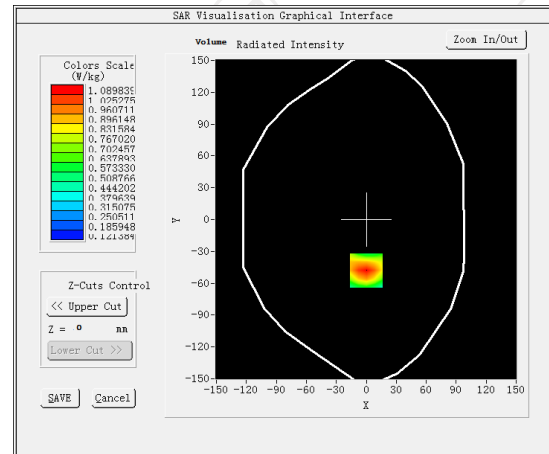

**Maximum location: X=0.00, Y=-48.00 SAR Peak: 1.56 W/kg**

**SAR 10g (W/Kg)**

0.347134

**SAR 1g (W/Kg)**

0.641439

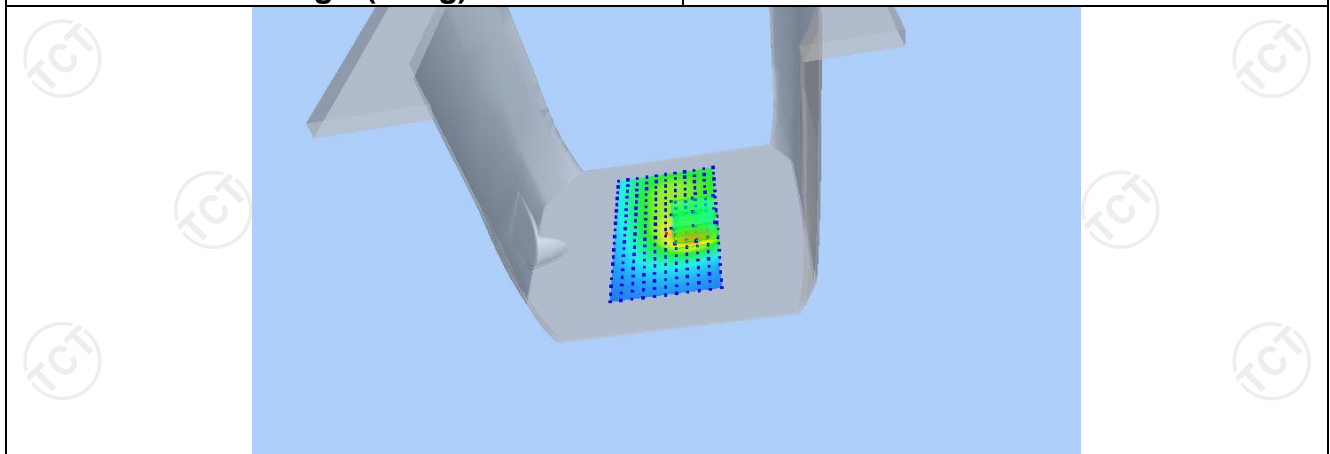

Z (mm)	0.00	4.00	9.00	14.00	19.00
SAR (W/Kg)	1.0080	0.6627	0.3834	0.2220	0.1320

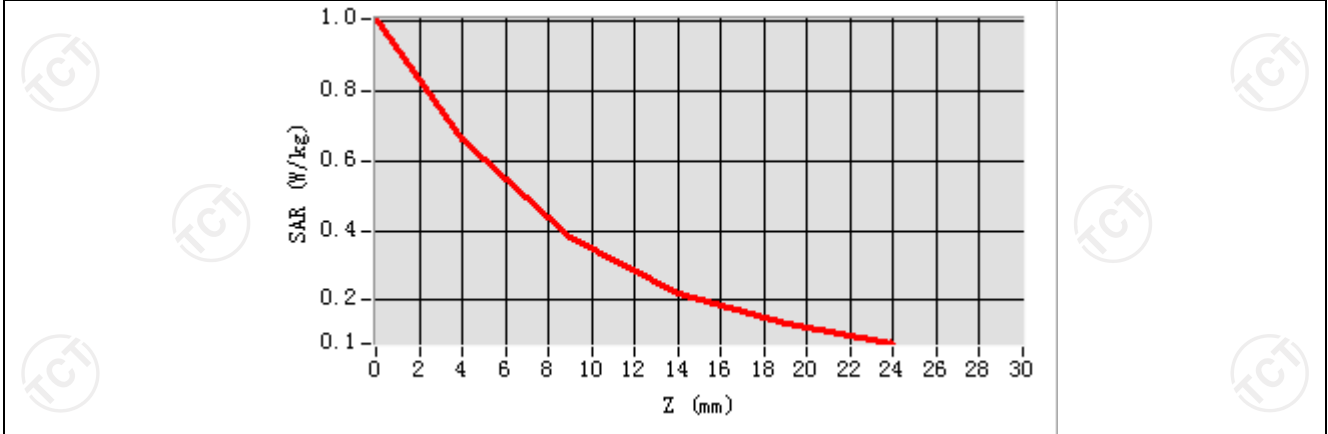

Hot spot position

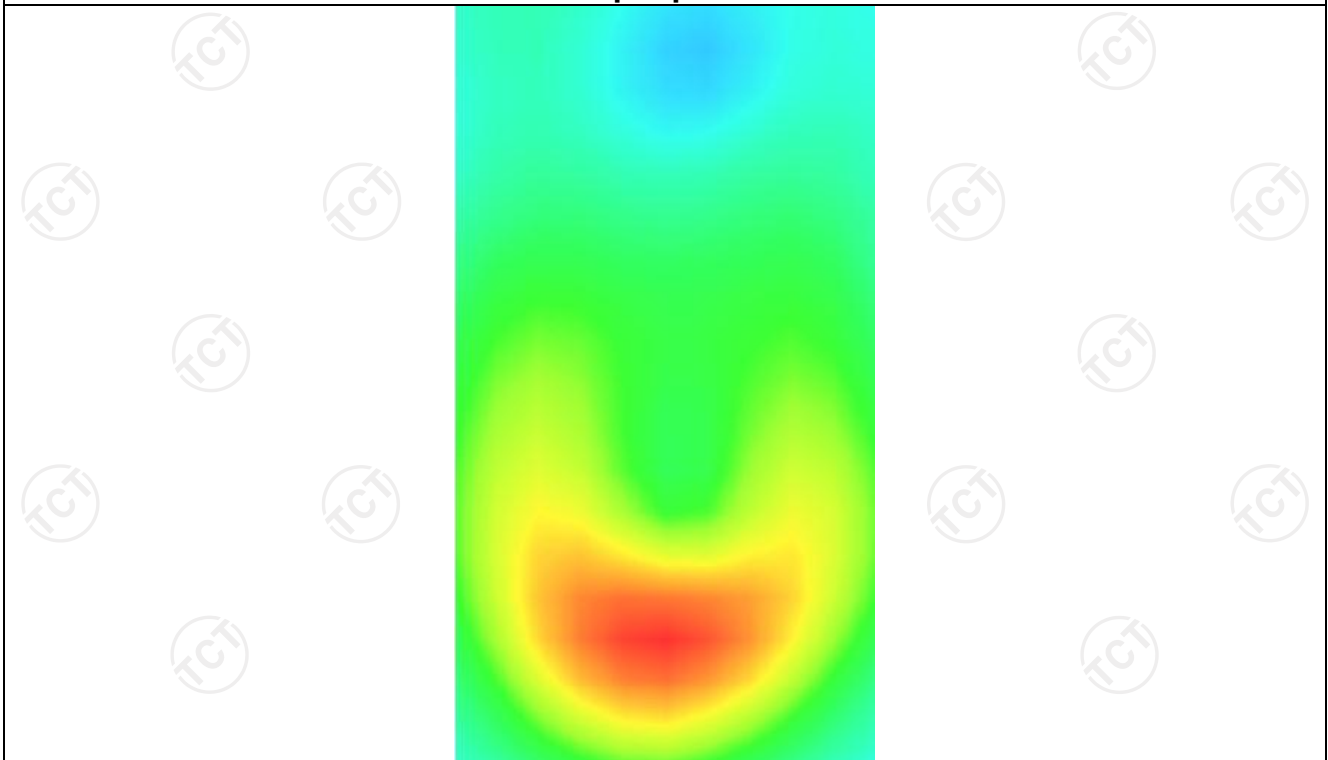

WCDMA Band IV  
**MEASUREMENT 1**

Hight Band SAR (Channel 1513):

Date: 12/01/2021

<b>Frequency (MHz)</b>	1752.600000
<b>Relative permittivity (real part)</b>	53.312521
<b>Relative permittivity (imaginary part)</b>	14.225400
<b>Conductivity (S/m)</b>	1.512530
<b>Variation (%)</b>	-0.230000
<b>Crest Factor</b>	1.0
<b>Probe Conversion factor</b>	2.16
<b>E-Field Probe:</b>	SSE2 (SN 36/20 EPGO346)
<b>Area Scan</b>	<u>dx=8mm dy=8mm, h= 5.00 mm</u>
<b>ZoomScan</b>	<u>5x5x7, dx=8mm dy=8mm</u> <u>dz=5mm, Complete/ndx=8mm dy=8mm, h=</u> <u>5.00 mm</u>
<b>Phantom</b>	<u>Validation plane</u>
<b>Device Position</b>	<u>Body back(10mm)</u>
<b>Band</b>	<u>BAND4 WCDMA1700</u>

**SURFACE SAR**

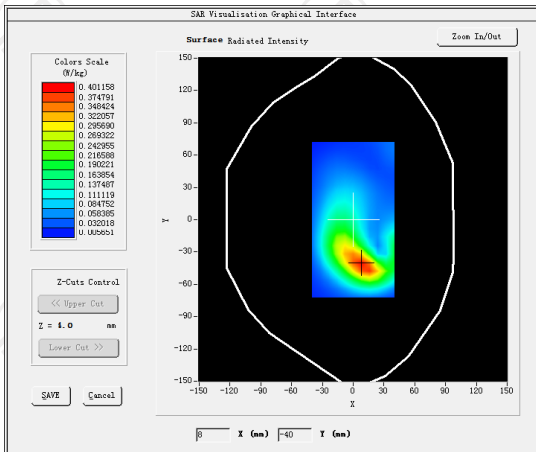

**VOLUME SAR**

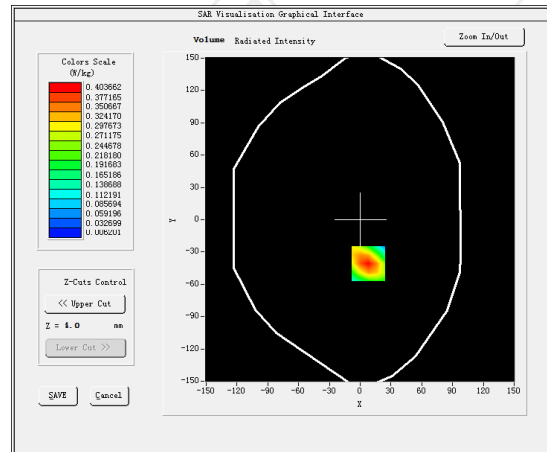

**Maximum location: X=8.00, Y=-41.00 SAR Peak: 0.60 W/kg**

**SAR 10g (W/Kg)**

0.215418

**SAR 1g (W/Kg)**

0.377408

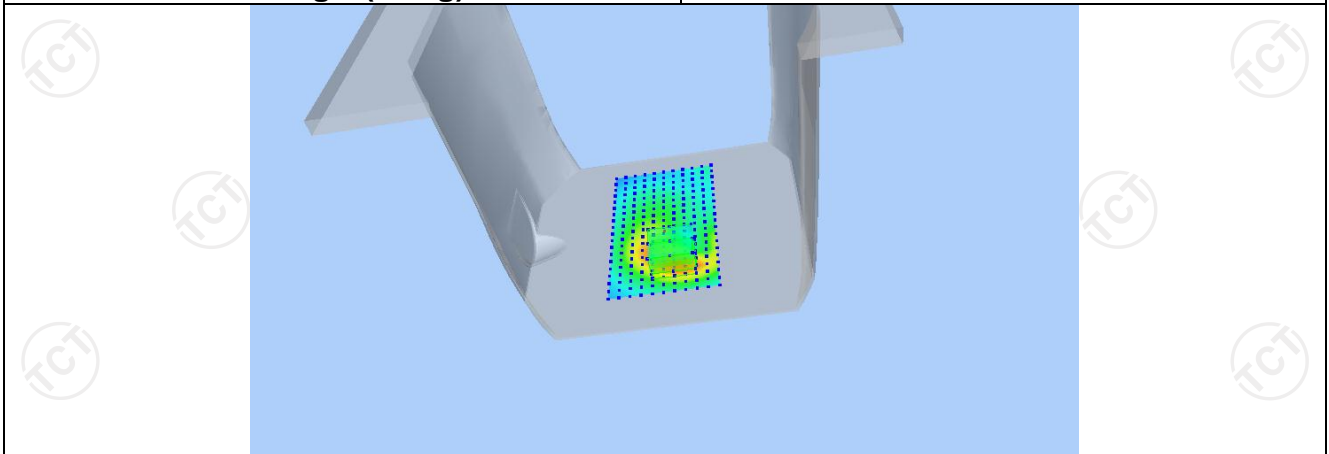

Z (mm)	0.00	4.00	9.00	14.00	19.00
SAR (W/Kg)	0.5985	0.4037	0.2429	0.1473	0.0922

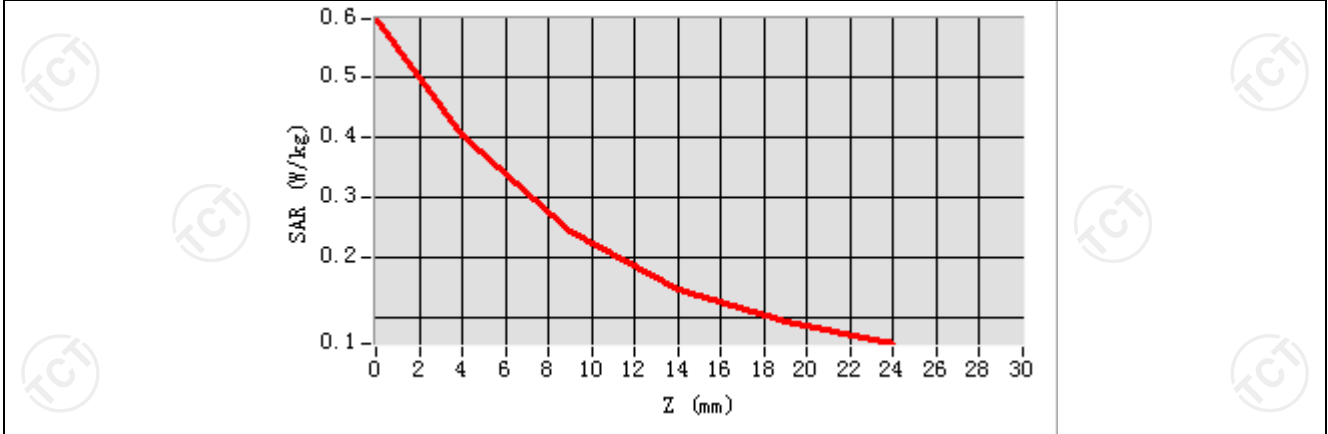

Hot spot position

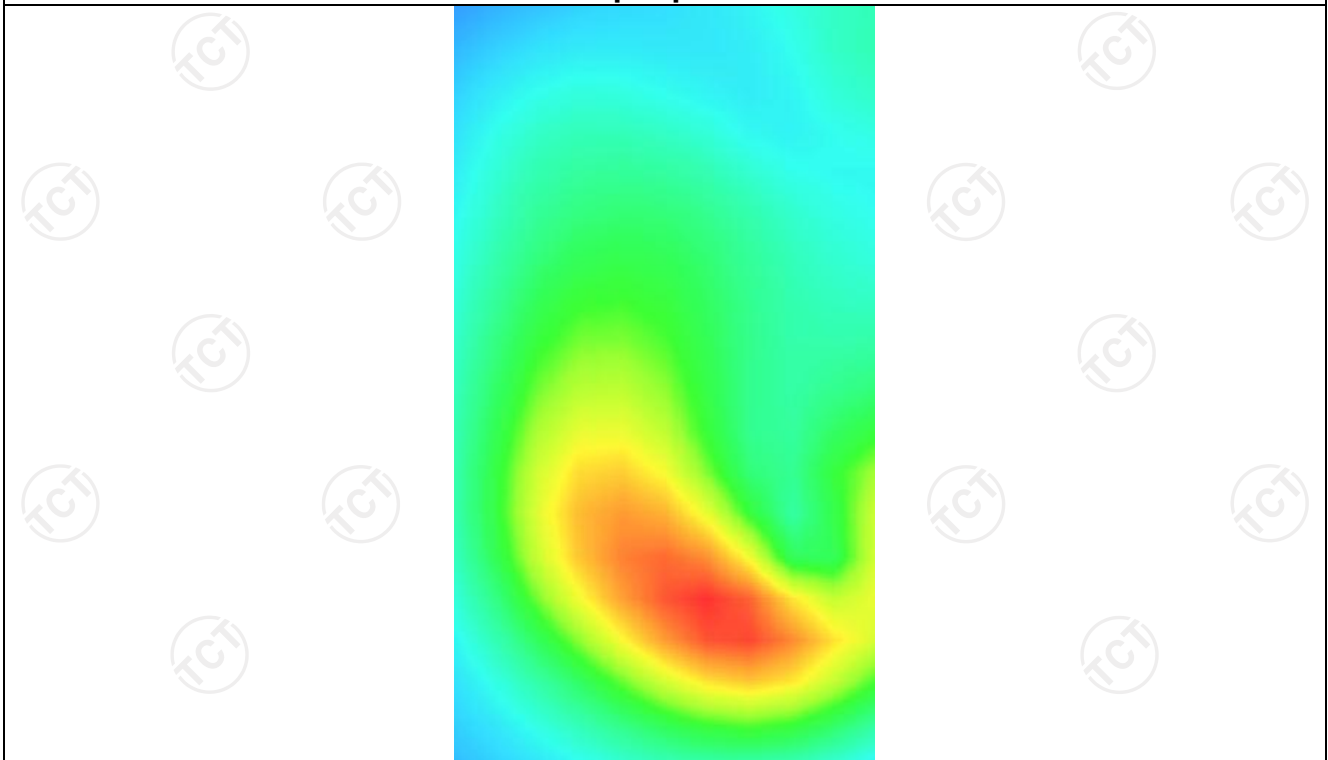

**MEASUREMENT 2**

Hight Band SAR (Channel 1513):

Date: 12/01/2021

<b>Frequency (MHz)</b>	1752.600000
<b>Relative permittivity (real part)</b>	53.312521
<b>Relative permittivity (imaginary part)</b>	14.225400
<b>Conductivity (S/m)</b>	1.512530
<b>Variation (%)</b>	-0.800000
<b>Crest Factor</b>	1.0
<b>Probe Conversion factor</b>	2.16
<b>E-Field Probe:</b>	SSE2 (SN 36/20 EPGO346)
<b>Area Scan</b>	<u>dx=8mm dy=8mm, h= 5.00 mm</u>
<b>ZoomScan</b>	<u>5x5x7, dx=8mm dy=8mm</u> <u>dz=5mm, Complete/ndx=8mm dy=8mm, h=</u> <u>5.00 mm</u>
<b>Phantom</b>	<u>Validation plane</u>
<b>Device Position</b>	<u>Body back (10mm)</u>
<b>Band</b>	<u>BAND4 WCDMA1700(hotspot)</u>

**SURFACE SAR**

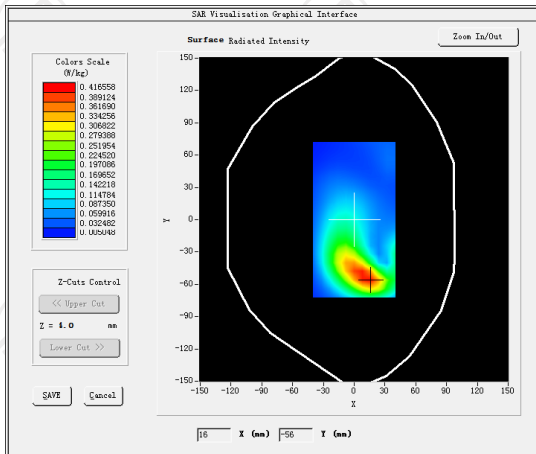

**VOLUME SAR**

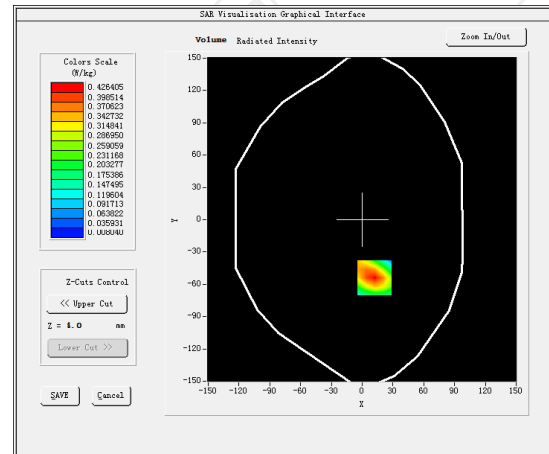

**Maximum location: X=12.00, Y=-54.00 SAR Peak: 0.63 W/kg**

**SAR 10g (W/Kg)**

0.228778

**SAR 1g (W/Kg)**

0.399345

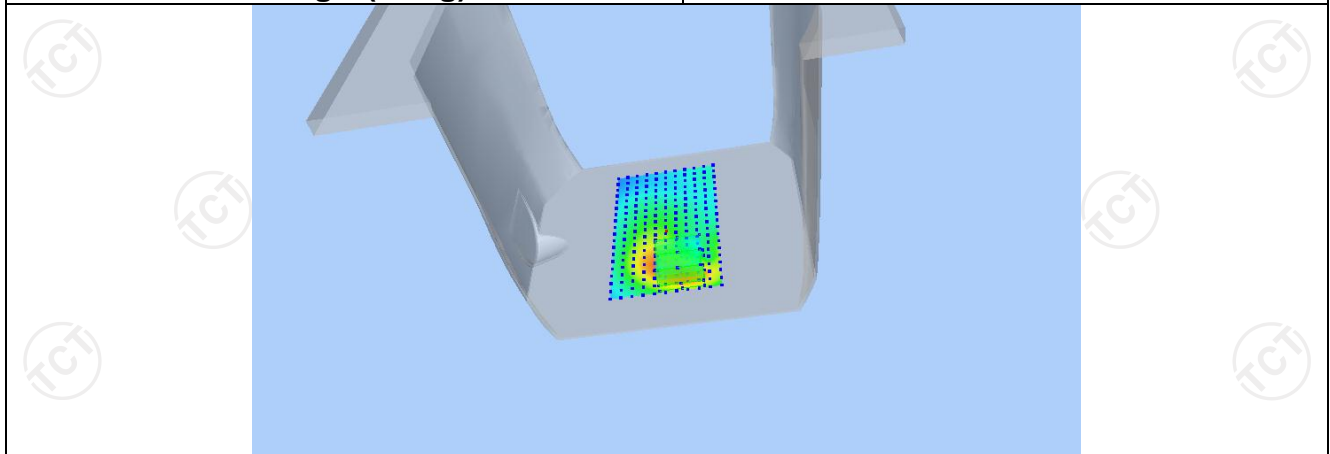

Z (mm)	0.00	4.00	9.00	14.00	19.00
SAR (W/Kg)	0.6279	0.4264	0.2585	0.1572	0.0977

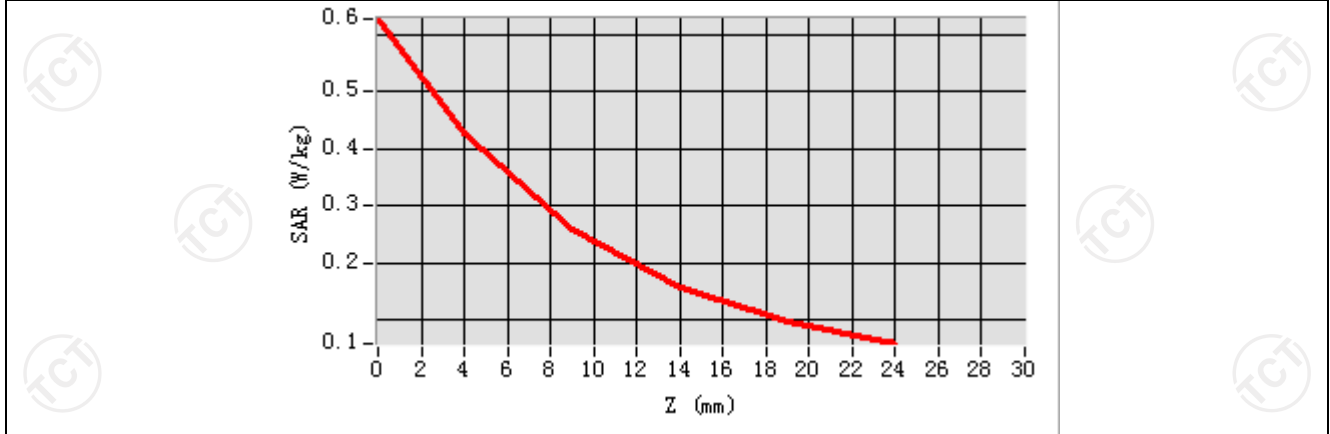

Hot spot position

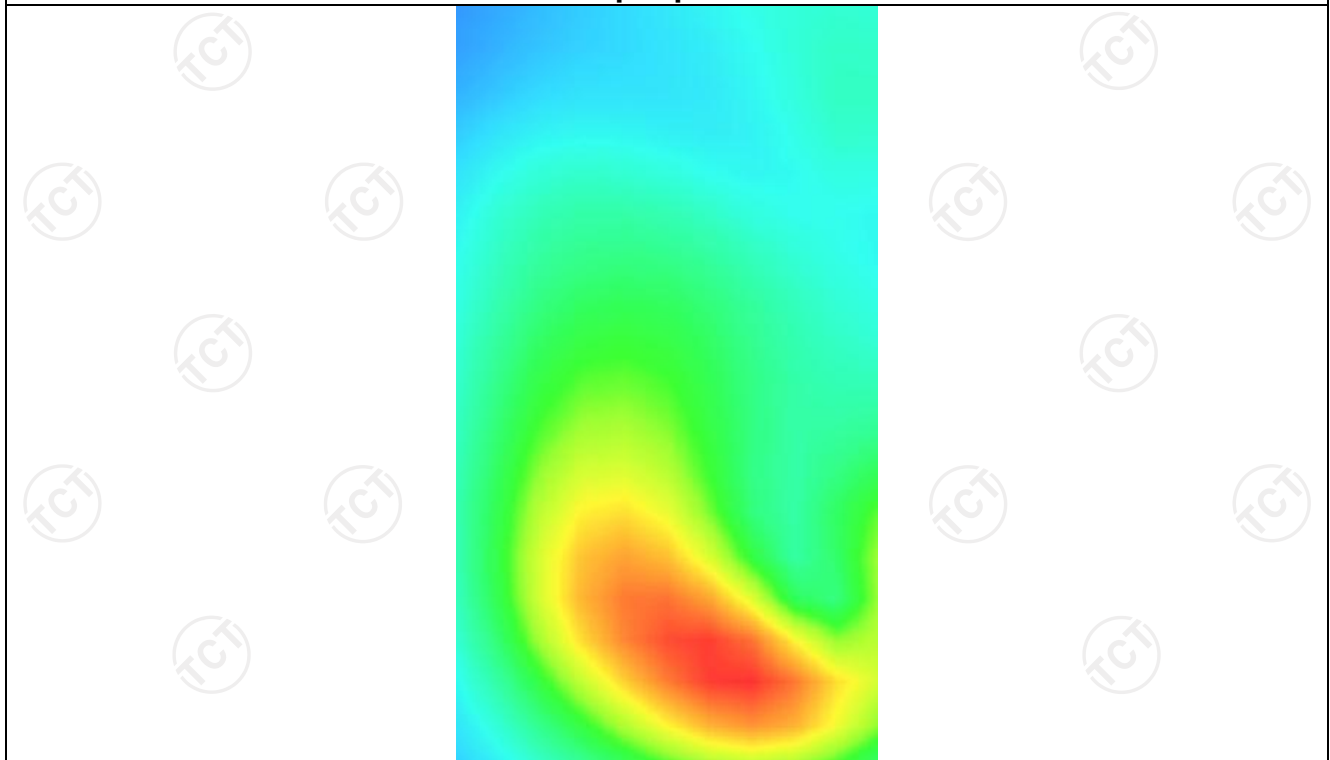

WCDMA Band V  
**MEASUREMENT 1**

Middle Band SAR (Channel 4182):

Date: 11/29/2021

<b>Frequency (MHz)</b>	836.400000
<b>Relative permittivity (real part)</b>	55.242927
<b>Relative permittivity (imaginary part)</b>	21.378266
<b>Conductivity (S/m)</b>	0.941230
<b>Variation (%)</b>	-1.160000
<b>Crest Factor:</b>	1.0
<b>Probe Conversion factor</b>	1.78
<b>E-Field Probe:</b>	SSE2 (SN 36/20 EPG0346)
<b>Area Scan</b>	<u>dx=8mm dy=8mm, h= 5.00 mm</u>
<b>ZoomScan</b>	<u>5x5x7,dx=8mm dy=8mm</u> <u>dz=5mm,Complete/ndx=8mm dy=8mm, h=</u> <u>5.00 mm</u>
<b>Phantom</b>	<u>Validation plane</u>
<b>Device Position</b>	<u>Body back(10mm)</u>
<b>Band</b>	<u>BAND5 WCDMA850</u>

**SURFACE SAR**

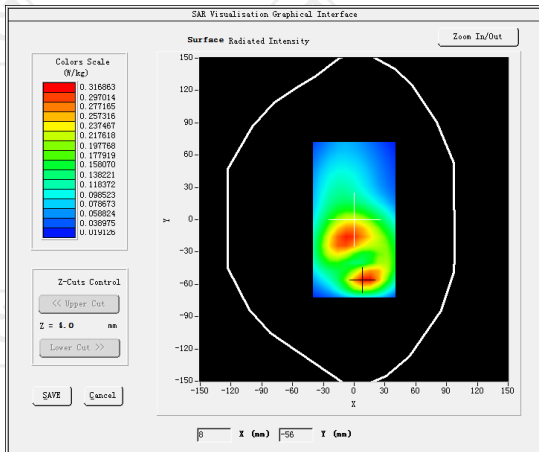

**VOLUME SAR**

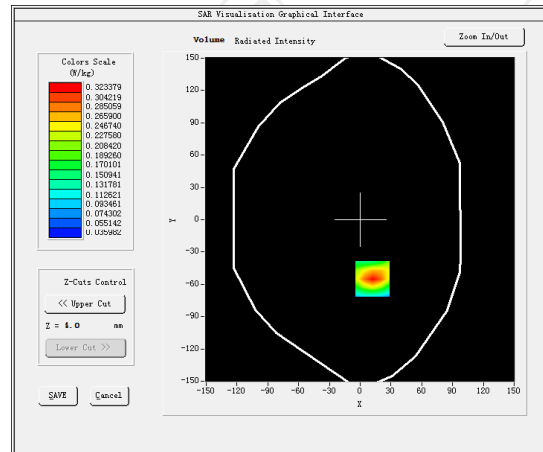

**Maximum location: X=11.00, Y=-50.00 SAR Peak: 0.23 W/kg**

**SAR 10g (W/Kg)**

0.089898

**SAR 1g (W/Kg)**

0.197819

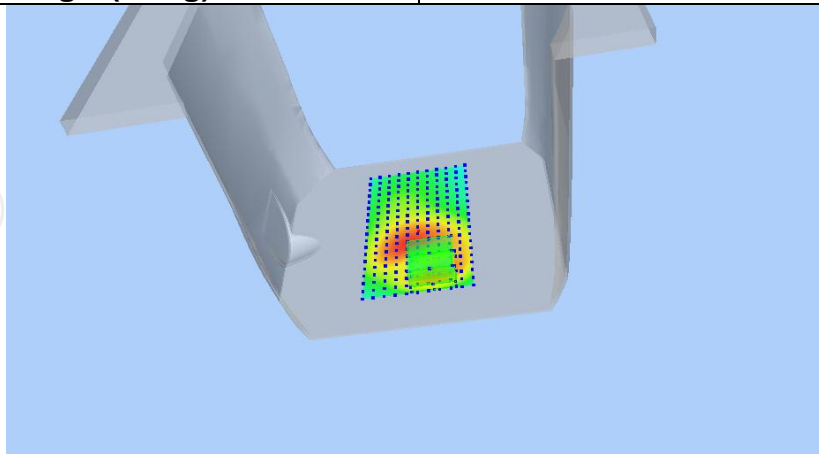



<b>Z (mm)</b>	<b>0.00</b>	<b>4.00</b>	<b>9.00</b>	<b>14.00</b>	<b>19.00</b>
<b>SAR (W/Kg)</b>	<b>0.2246</b>	<b>0.1549</b>	<b>0.0969</b>	<b>0.0622</b>	<b>0.0419</b>

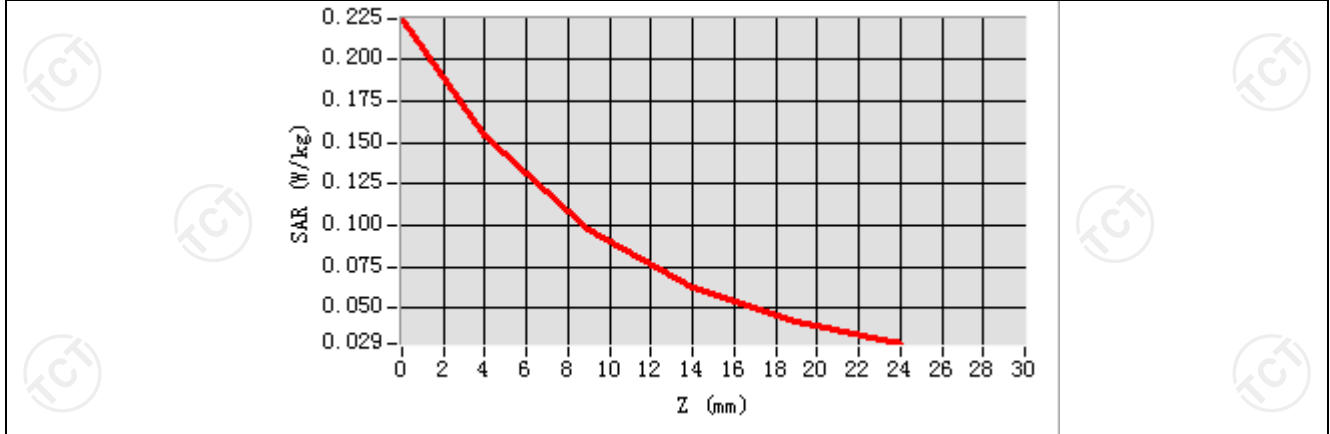

**Hot spot position**

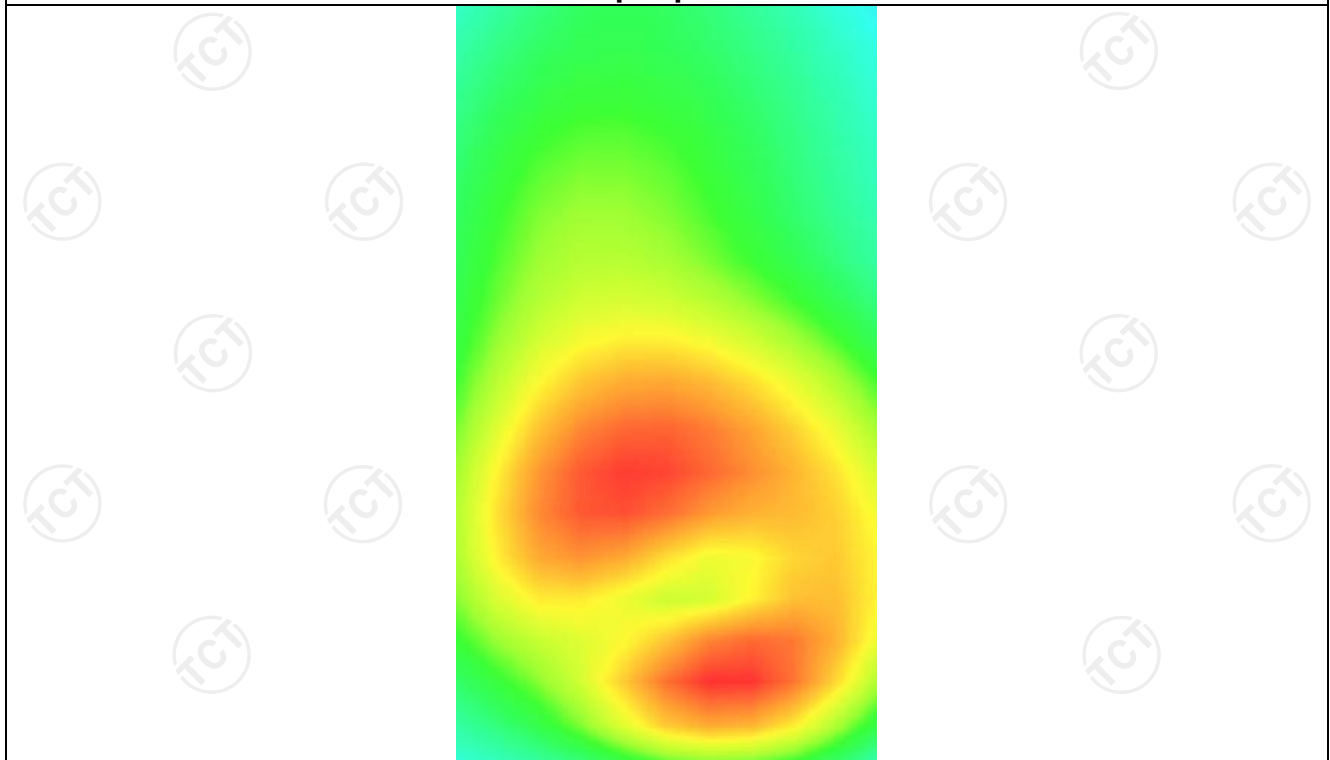

**MEASUREMENT 2**

Middle Band SAR (Channel 4182):

Date: 11/29/2021

Frequency (MHz)	836.400000
Relative permittivity (real part)	55.242927
Relative permittivity (imaginary part)	21.378266
Conductivity (S/m)	0.941230
Variation (%)	-2.410000
Crest Factor:	1.0
Probe Conversion factor	1.78
E-Field Probe:	SSE2 (SN 36/20 EPGO346)
Area Scan	<u>dx=8mm dy=8mm, h= 5.00 mm</u>
ZoomScan	<u>5x5x7,dx=8mm dy=8mm</u> <u>dz=5mm,Complete/ndx=8mm dy=8mm,</u> <u>h= 5.00 mm</u>
Phantom	<u>Validation plane</u>
Device Position	<u>Body back(10mm)</u>
Band	<u>BAND5_WCDMA850(hotspot)</u>

**SURFACE SAR**

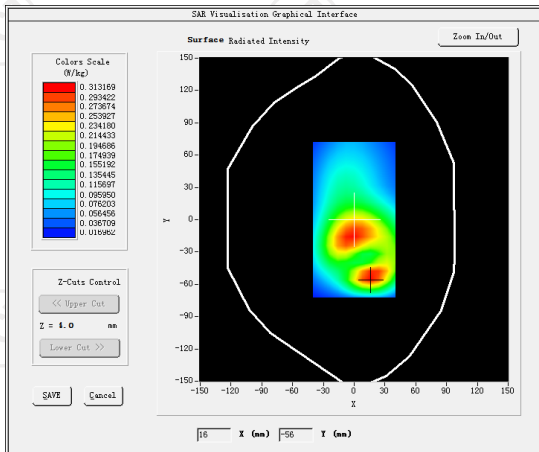

**VOLUME SAR**

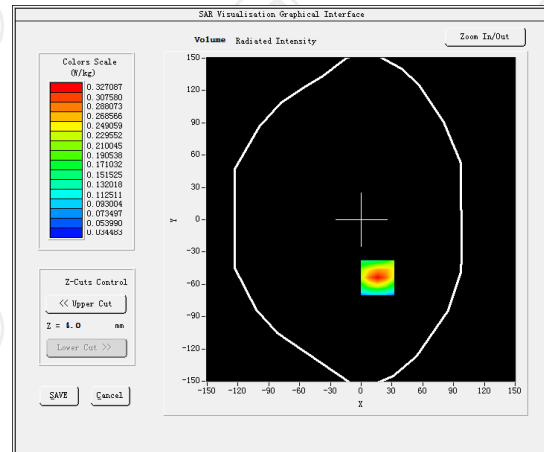

**Maximum location: X=19.00, Y=-58.00 SAR Peak: 0.23 W/kg**

**SAR 10g (W/Kg)**

0.092273

**SAR 1g (W/Kg)**

0.209034

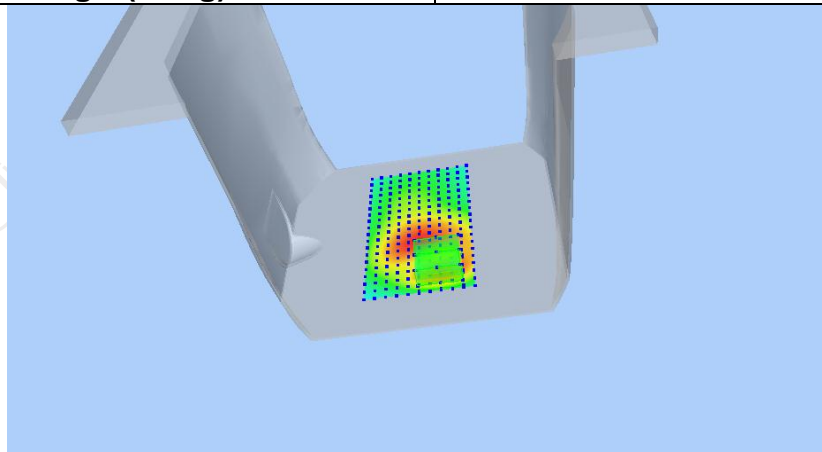

<b>Z (mm)</b>	<b>0.00</b>	<b>4.00</b>	<b>9.00</b>	<b>14.00</b>	<b>19.00</b>
<b>SAR (W/Kg)</b>	<b>0.2253</b>	<b>0.1557</b>	<b>0.0975</b>	<b>0.0631</b>	<b>0.0430</b>

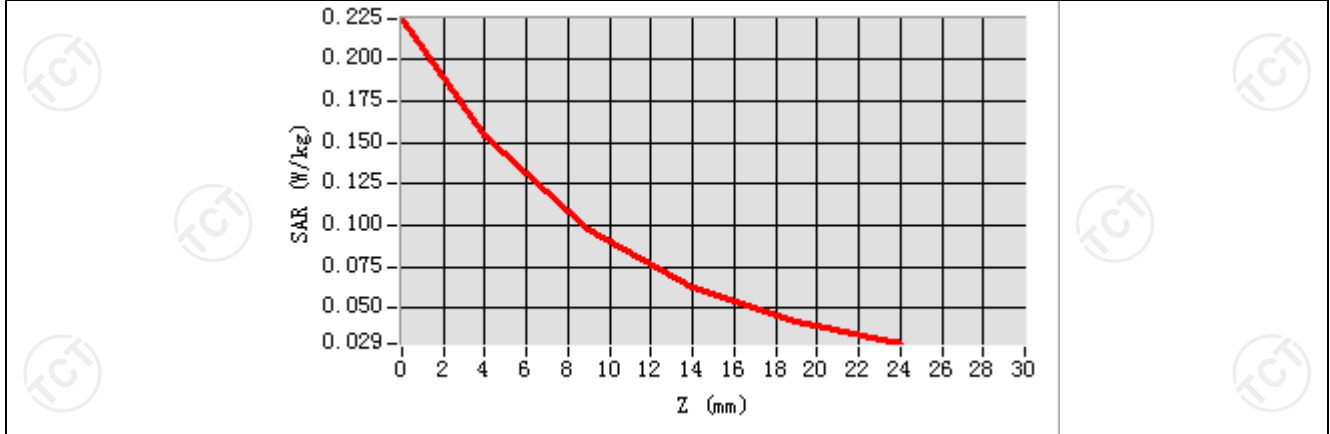

**Hot spot position**

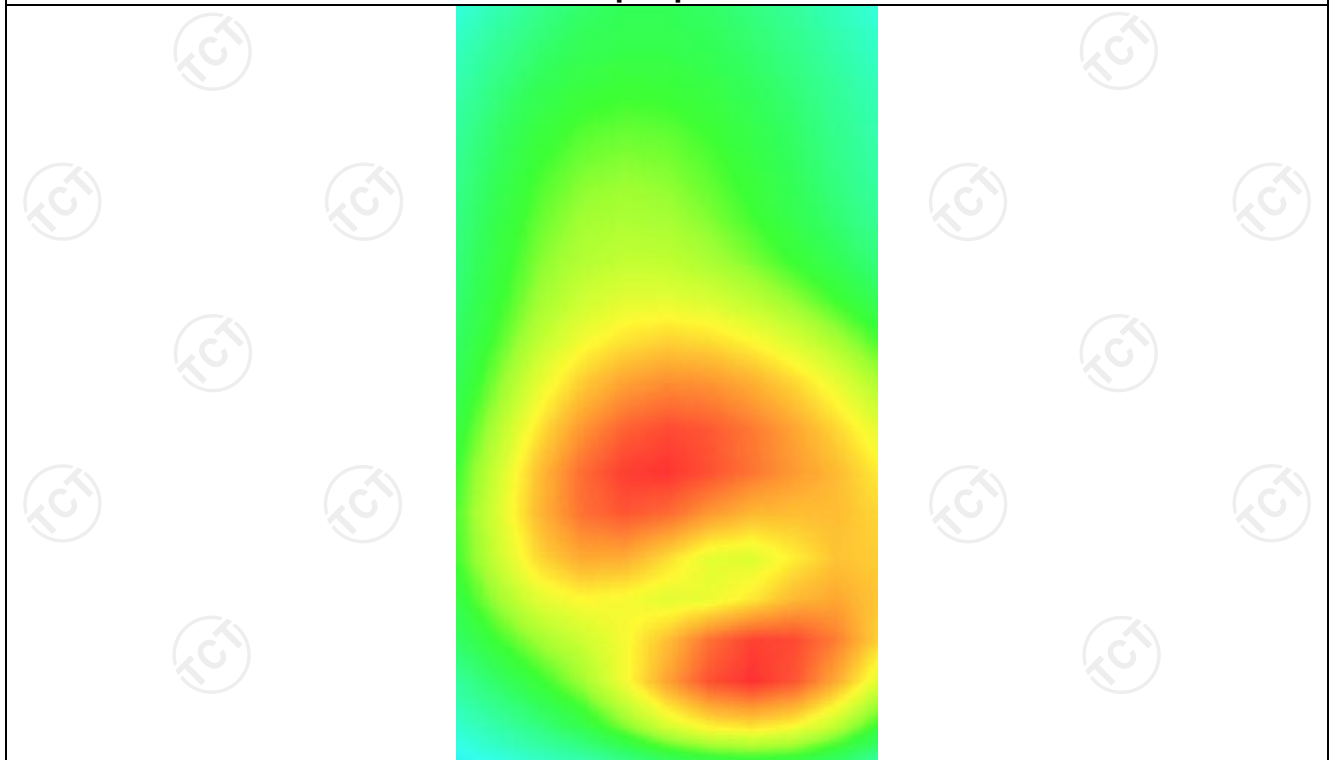

LTE Band 2

**MEASUREMENT 1**

Lower Band SAR (Channel 18700):

Date: 12/01/2021

<b>Frequency (MHz)</b>	1860.000000
<b>Relative permittivity (real part)</b>	53.321337
<b>Relative permittivity (imaginary part)</b>	14.232400
<b>Conductivity (S/m)</b>	1.501736
<b>Variation (%)</b>	2.180000
<b>Crest Factor</b>	1.0
<b>Probe Conversion factor</b>	2.16
<b>E-Field Probe:</b>	SSE2 (SN36/20 EPG0346)
<b>Area Scan</b>	<u>dx=8mm dy=8mm, h= 5.00 mm</u>
<b>ZoomScan</b>	<u>5x5x7,dx=8mm dy=8mm</u> <u>dz=5mm,Complete/ndx=8mm dy=8mm, h=</u> <u>5.00 mm</u>
<b>Phantom</b>	<u>Validation plane</u>
<b>Device Position</b>	<u>Body back(10mm)</u>
<b>Band</b>	<u>LTE band 2 (1 RB#49)</u>

**SURFACE SAR**

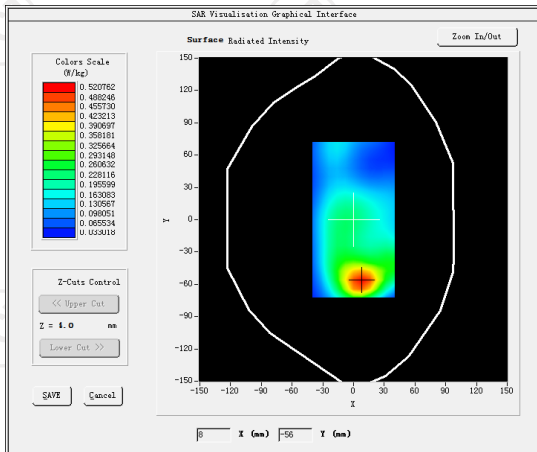

**VOLUME SAR**

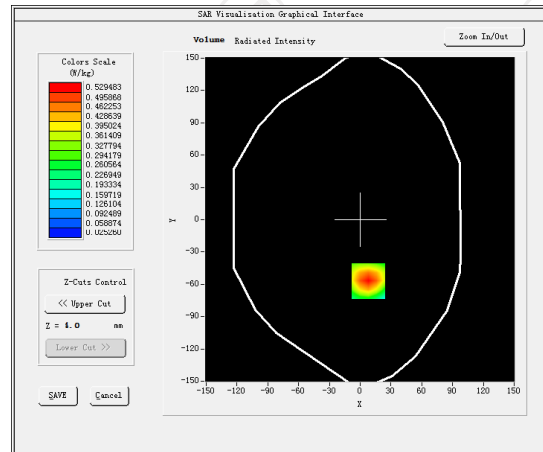

**Maximum location: X=18.00, Y=-37.00 SAR Peak: 0.79 W/kg**

**SAR 10g (W/Kg)**

0.285447

**SAR 1g (W/Kg)**

0.507064

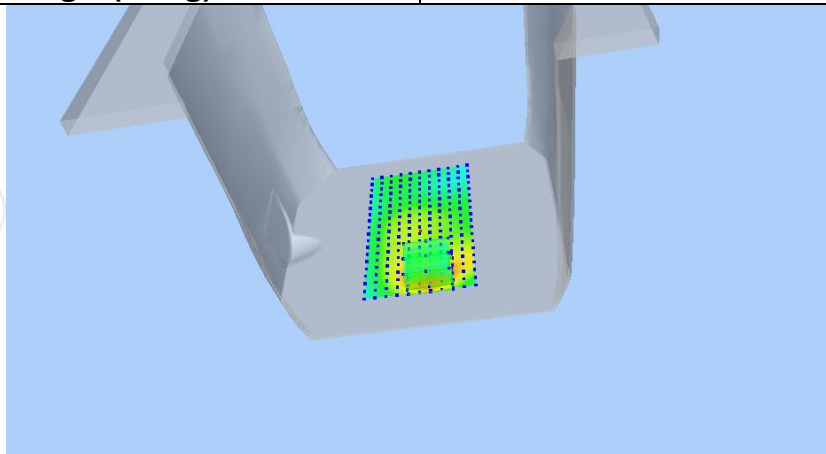

Z (mm)	0.00	4.00	9.00	14.00	19.00
SAR (W/Kg)	0.7921	0.5295	0.3141	0.1871	0.1145

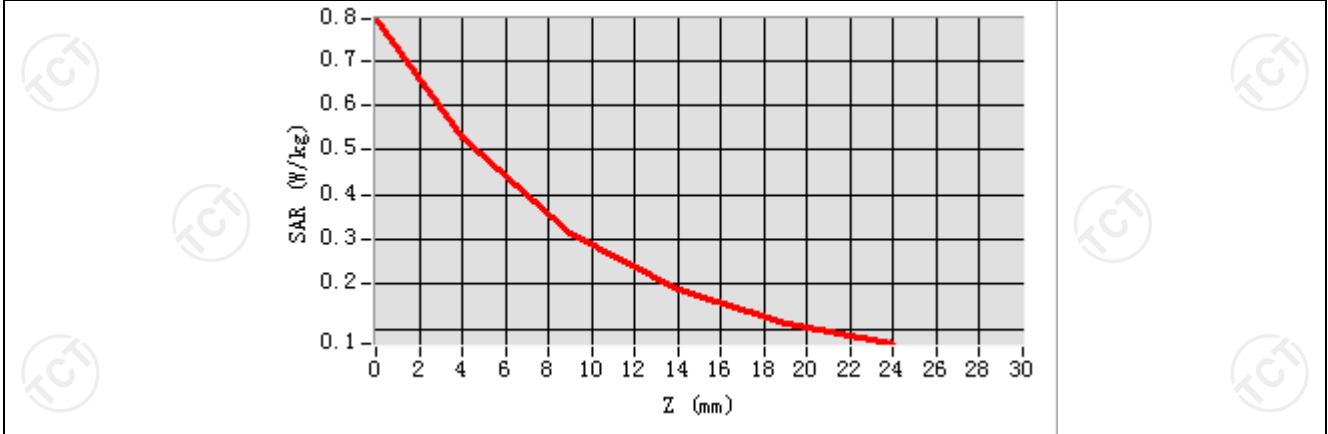

Hot spot position

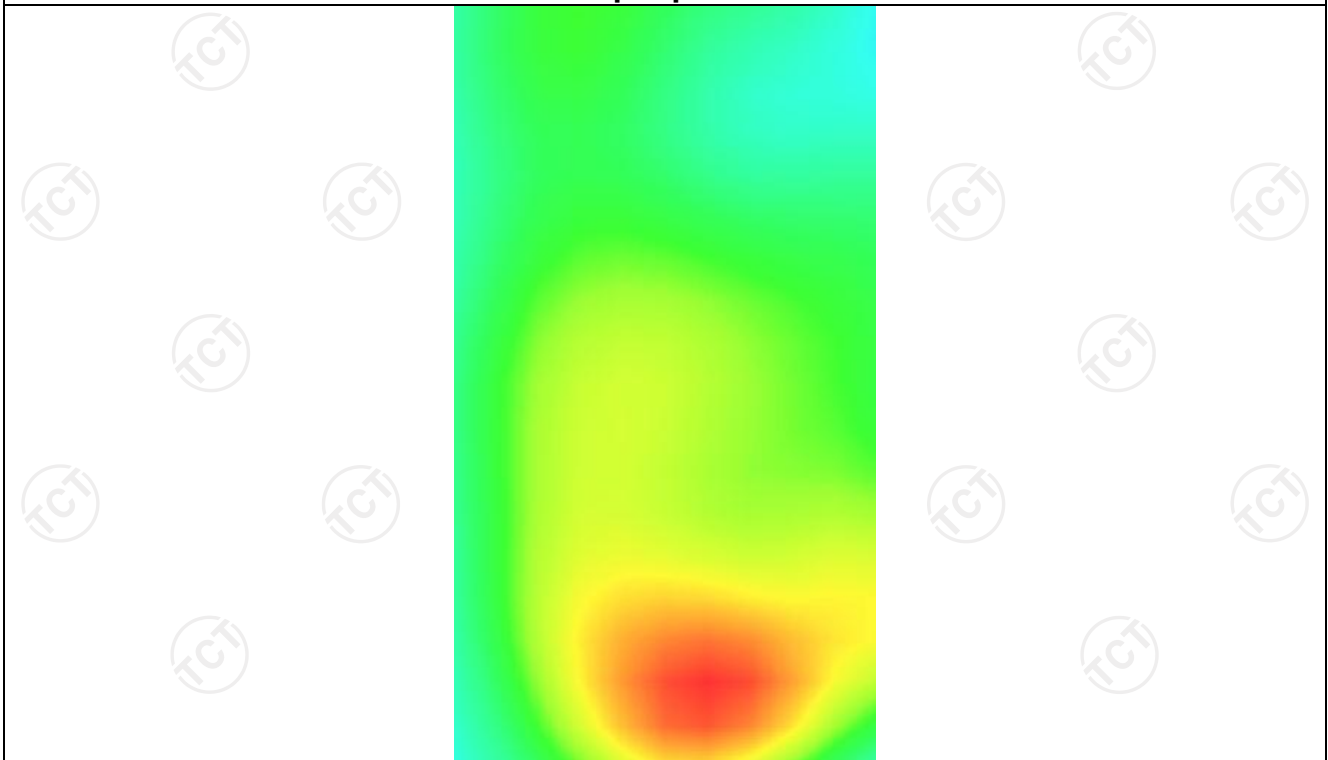

**MEASUREMENT 2**

Lower Band SAR (Channel 18700):

Date: 12/01/2021

<b>Frequency (MHz)</b>	1860.000000
<b>Relative permittivity (real part)</b>	53.321337
<b>Relative permittivity (imaginary part)</b>	14.232400
<b>Conductivity (S/m)</b>	1.501736
<b>Variation (%)</b>	-1.030000
<b>Crest Factor</b>	1.0
<b>Probe Conversion factor</b>	2.16
<b>E-Field Probe:</b>	SSE2 (SN36/20 EPGO346)
<b>Area Scan</b>	<u>dx=8mm dy=8mm, h= 5.00 mm</u>
<b>ZoomScan</b>	<u>5x5x7,dx=8mm dy=8mm</u> <u>dz=5mm,Complete/ndx=8mm dy=8mm, h=</u> <u>5.00 mm</u>
<b>Phantom</b>	<u>Validation plane</u>
<b>Device Position</b>	<u>Body back(hotspot 10mm)</u>
<b>Band</b>	<u>LTE band 2 (1 RB#49)</u>

**SURFACE SAR**

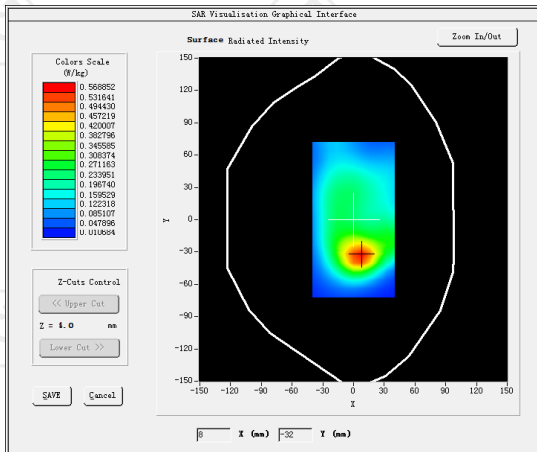

**VOLUME SAR**

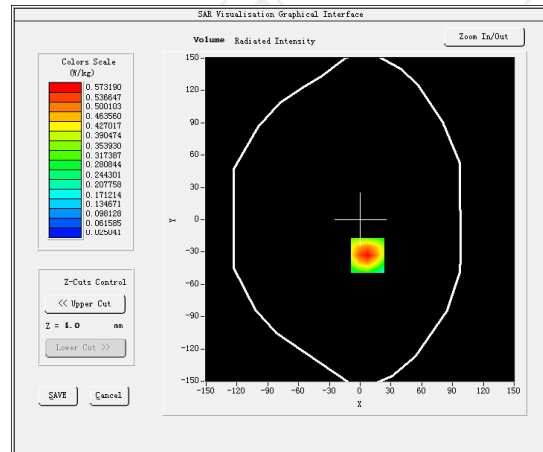

**Maximum location: X=7.00, Y=-33.00 SAR Peak: 0.87 W/kg**

**SAR 10g (W/Kg)**

0.306230

**SAR 1g (W/Kg)**

0.548711

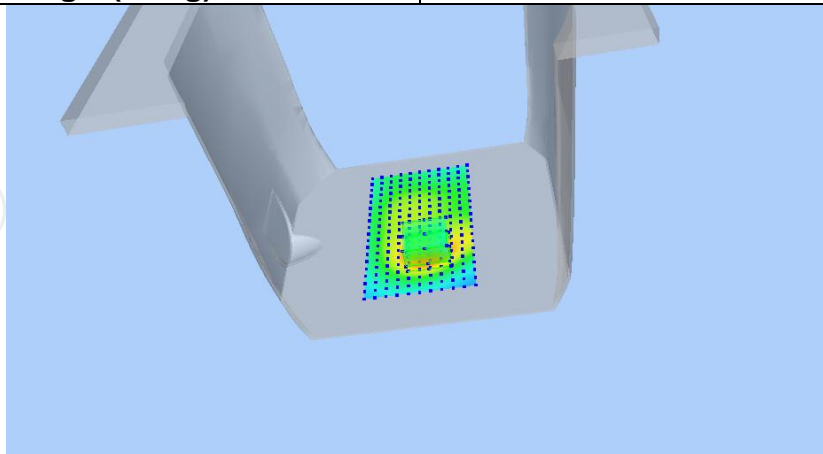

<b>Z (mm)</b>	<b>0.00</b>	<b>4.00</b>	<b>9.00</b>	<b>14.00</b>	<b>19.00</b>
<b>SAR (W/Kg)</b>	<b>0.9040</b>	<b>0.5731</b>	<b>0.3313</b>	<b>0.1931</b>	<b>0.1170</b>

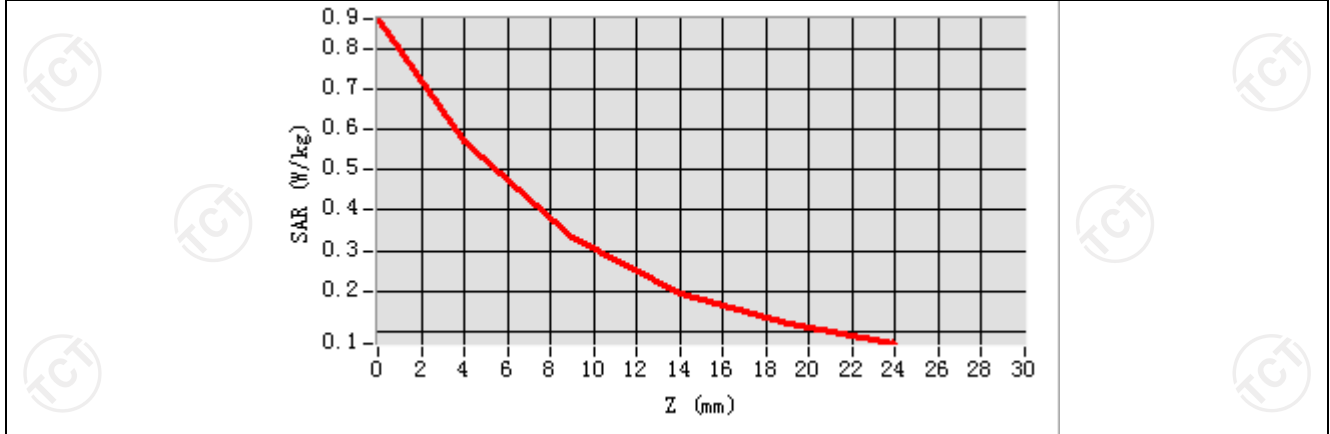

**Hot spot position**

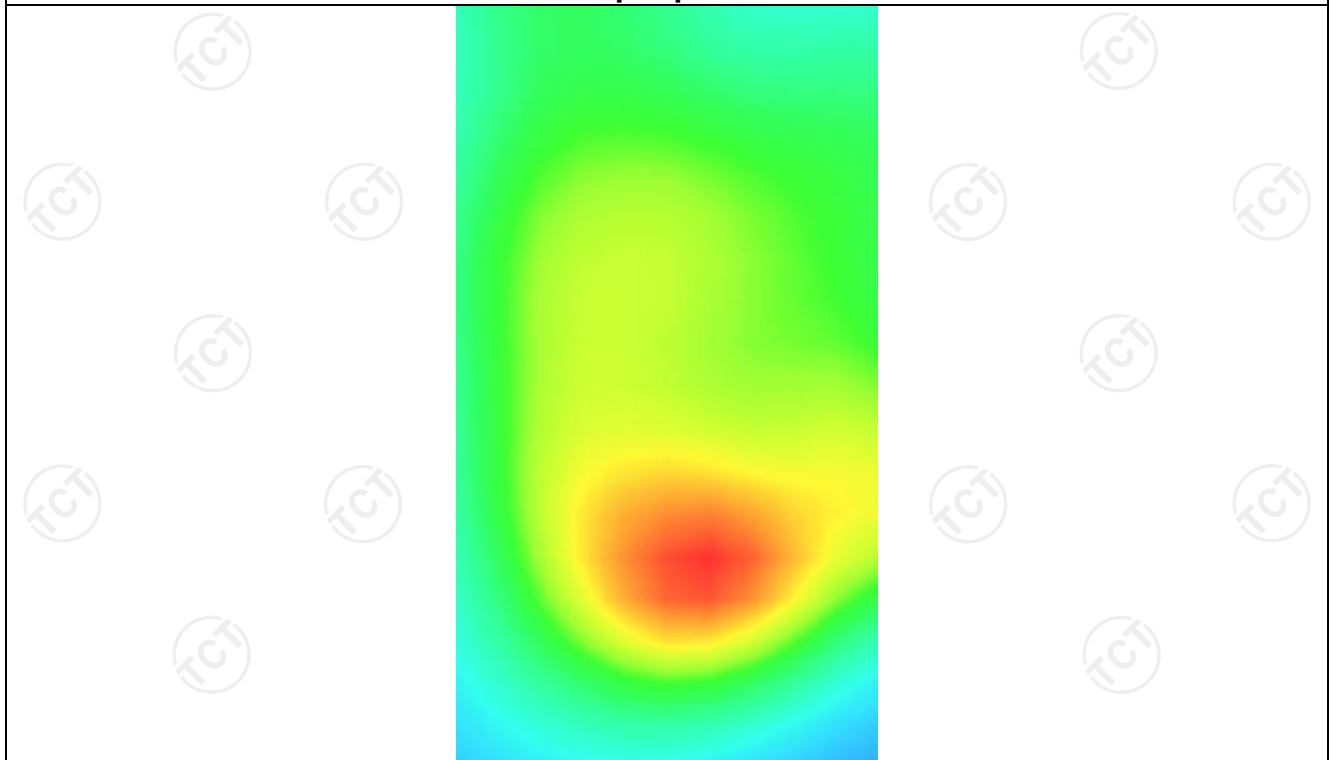

LTE Band 4

**MEASUREMENT 1**

Hight Band SAR (Channel 20300):

Date: 12/01/2021

<b>Frequency (MHz)</b>	1745.000000
<b>Relative permittivity (real part)</b>	53.311249
<b>Relative permittivity (imaginary part)</b>	12.468850
<b>Conductivity (S/m)</b>	1.512592
<b>Variation (%)</b>	-0.350000
<b>Crest Factor</b>	1.0
<b>Probe Conversion factor</b>	2.16
<b>E-Field Probe:</b>	SSE2 (SN 36/20 EPGO346)
<b>Area Scan</b>	<u>dx=8mm dy=8mm, h= 5.00 mm</u>
<b>ZoomScan</b>	<u>5x5x7,dx=8mm dy=8mm</u> <u>dz=5mm,Complete/ndx=8mm dy=8mm, h=</u> <u>5.00 mm</u>
<b>Phantom</b>	<u>Validation plane</u>
<b>Device Position</b>	<u>Body back(10mm)</u>
<b>Band</b>	<u>LTE band 4(1 RB#49)</u>

**SURFACE SAR**

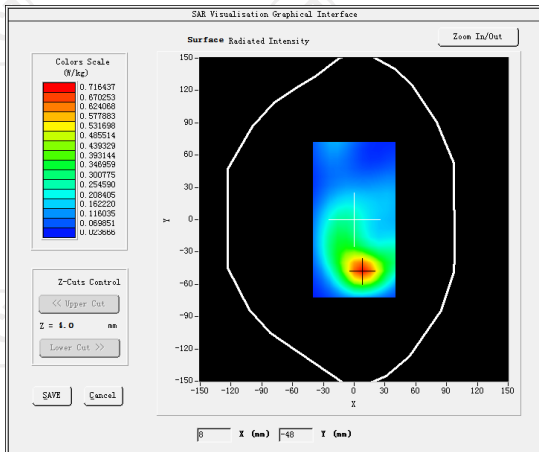

**VOLUME SAR**

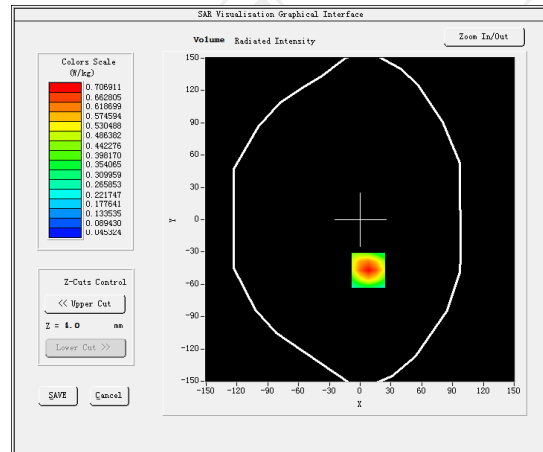

**Maximum location: X=8.00, Y=-47.00 SAR Peak: 1.01 W/kg**

**SAR 10g (W/Kg)**

0.390679

**SAR 1g (W/Kg)**

0.653149

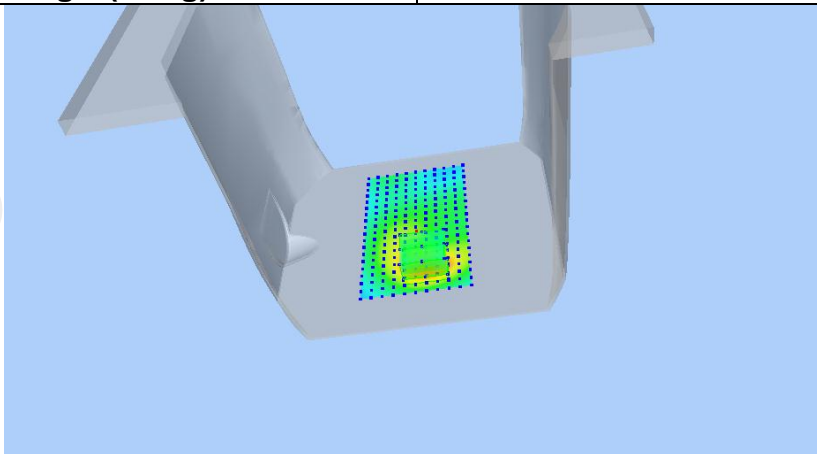



<b>Z (mm)</b>	<b>0.00</b>	<b>4.00</b>	<b>9.00</b>	<b>14.00</b>	<b>19.00</b>
<b>SAR (W/Kg)</b>	<b>1.0069</b>	<b>0.7071</b>	<b>0.4460</b>	<b>0.2820</b>	<b>0.1710</b>

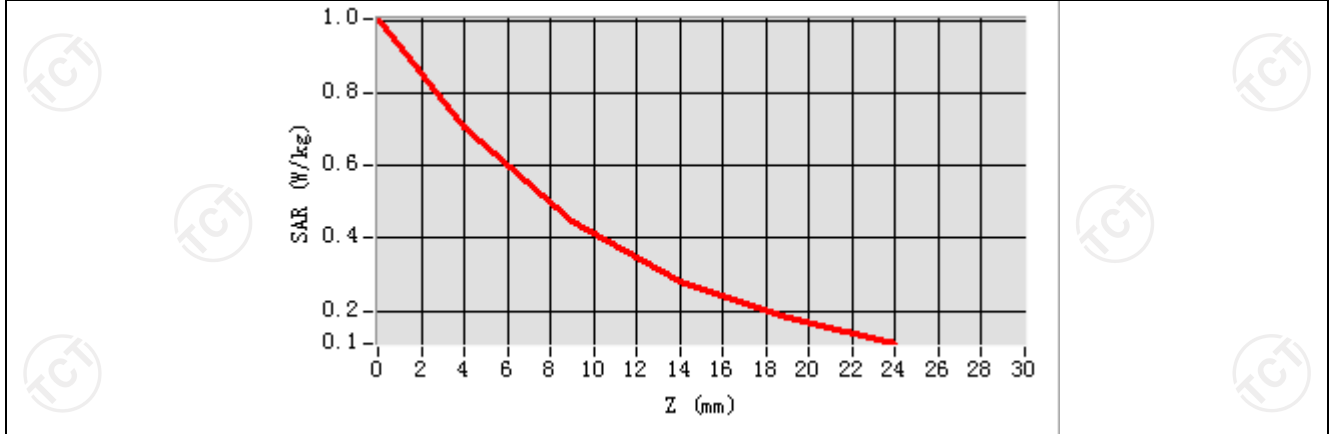

**Hot spot position**

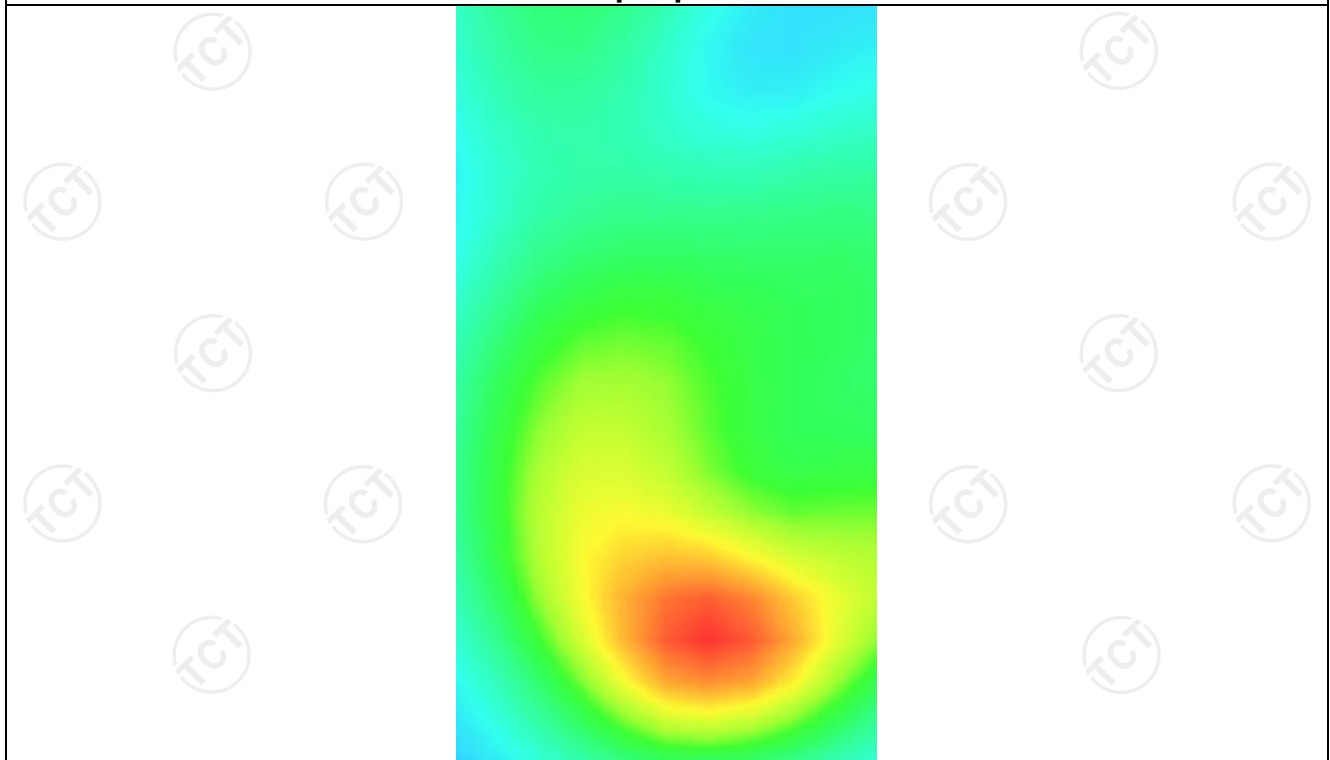

**MEASUREMENT 2**

Hight Band SAR (Channel 20300):

Date: 12/01/2021

<b>Frequency (MHz)</b>	1745.000000
<b>Relative permittivity (real part)</b>	53.311249
<b>Relative permittivity (imaginary part)</b>	12.468850
<b>Conductivity (S/m)</b>	1.512592
<b>Variation (%)</b>	-0.290000
<b>Crest Factor</b>	1.0
<b>Probe Conversion factor</b>	2.16
<b>E-Field Probe:</b>	SSE2 (SN 36/20 EPGO346)
<b>Area Scan</b>	<u>dx=8mm dy=8mm, h= 5.00 mm</u>
<b>ZoomScan</b>	<u>5x5x7,dx=8mm dy=8mm</u> <u>dz=5mm,Complete/ndx=8mm dy=8mm, h=</u> <u>5.00 mm</u>
<b>Phantom</b>	<u>Validation plane</u>
<b>Device Position</b>	<u>Body back(hotspot 10mm)</u>
<b>Band</b>	<u>LTE band 4(1 RB#49)</u>

**SURFACE SAR**

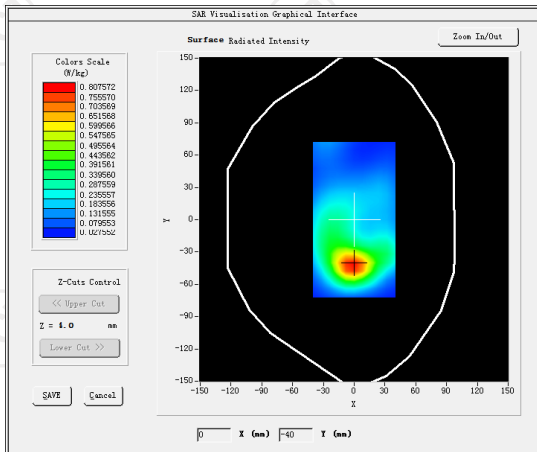

**VOLUME SAR**

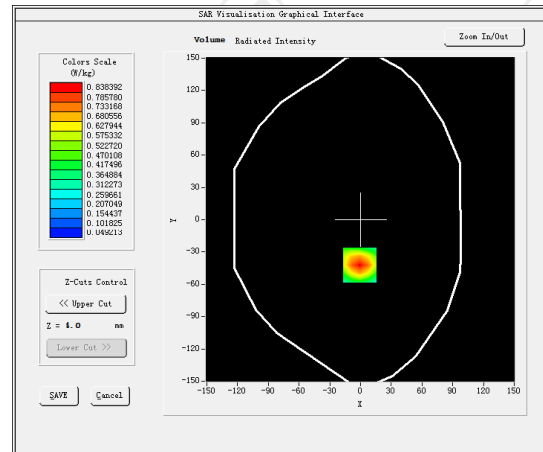

**Maximum location: X=-1.00, Y=-42.00 SAR Peak: 1.22 W/kg**

**SAR 10g (W/Kg)**

0.413559

**SAR 1g (W/Kg)**

0.673801

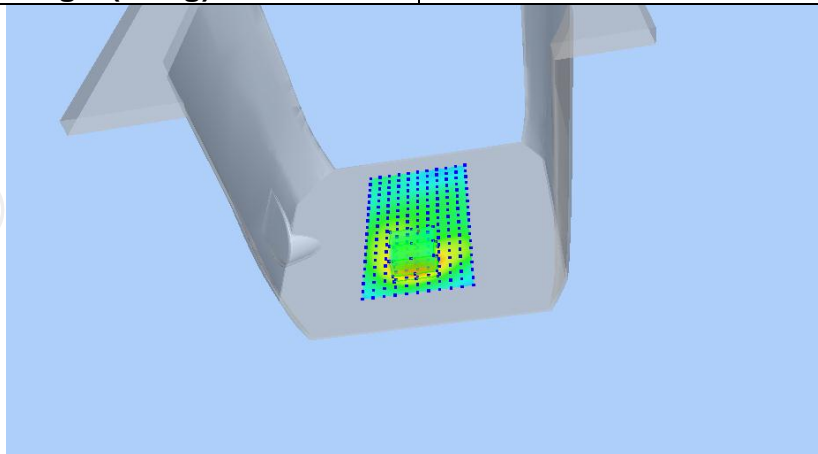

Z (mm)	0.00	4.00	9.00	14.00	19.00
SAR (W/Kg)	1.2161	0.8382	0.5180	0.3211	0.2020

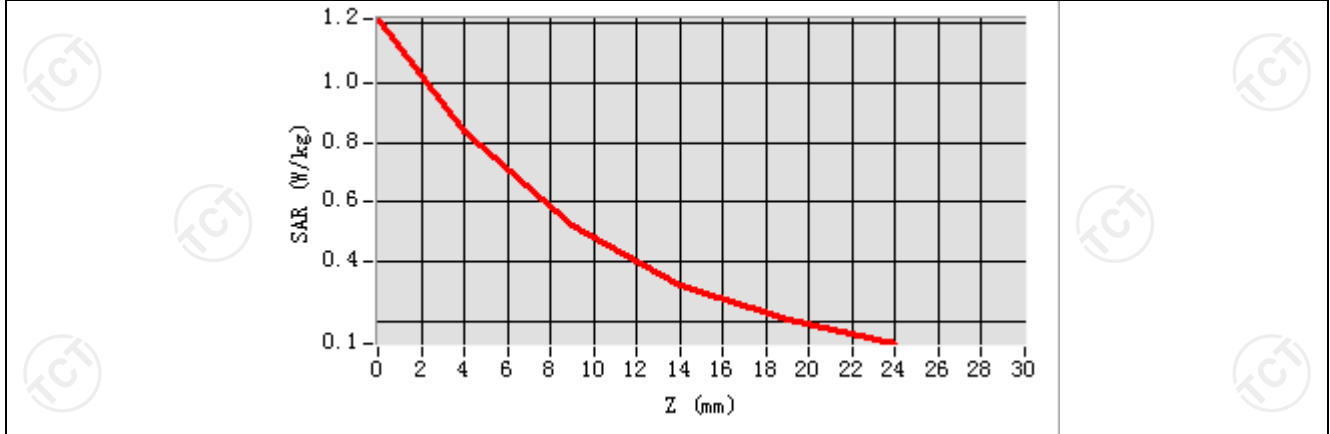

Hot spot position

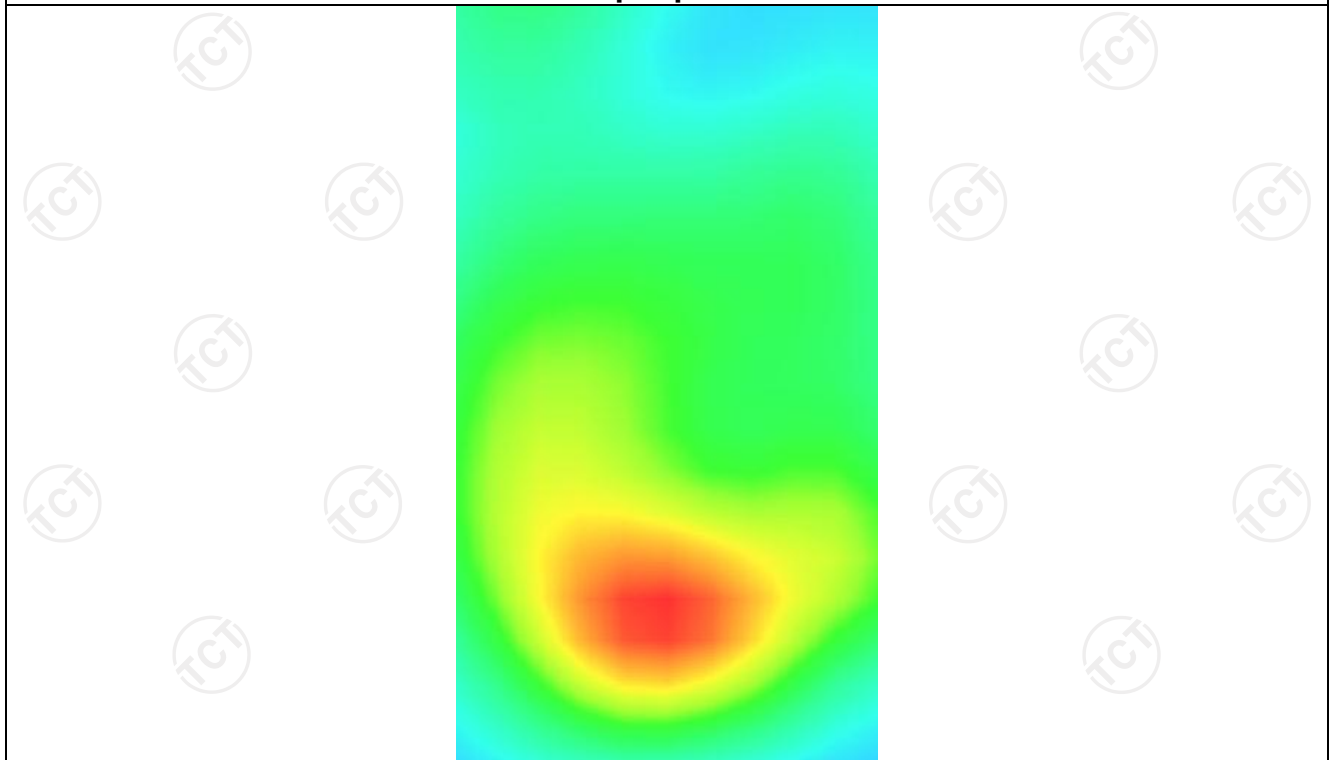

LTE Band 5

**MEASUREMENT 1**

Middle Band SAR (Channel 20525):

Date: 11/29/2021

<b>Frequency (MHz)</b>	836.500000
<b>Relative permittivity (real part)</b>	55.240832
<b>Relative permittivity (imaginary part)</b>	12.468860
<b>Conductivity (S/m)</b>	0.944272
<b>Variation (%)</b>	-1.540000
<b>Crest Factor</b>	1.0
<b>Probe Conversion factor</b>	1.78
<b>E-Field Probe:</b>	SSE2 (SN 36/20 EPG0346)
<b>Area Scan</b>	<u>dx=8mm dy=8mm, h= 5.00 mm</u>
<b>ZoomScan</b>	<u>5x5x7,dx=8mm dy=8mm</u> <u>dz=5mm,Complete/ndx=8mm dy=8mm, h=</u> <u>5.00 mm</u>
<b>Phantom</b>	<u>Validation plane</u>
<b>Device Position</b>	<u>Body back(10mm)</u>
<b>Band</b>	<u>LTE band 5(1 RB#24)</u>

**SURFACE SAR**

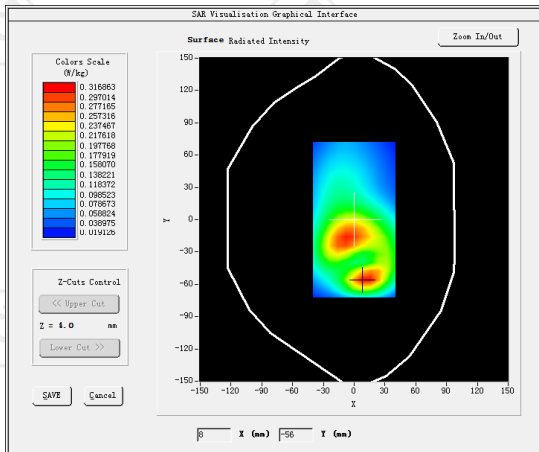

**VOLUME SAR**

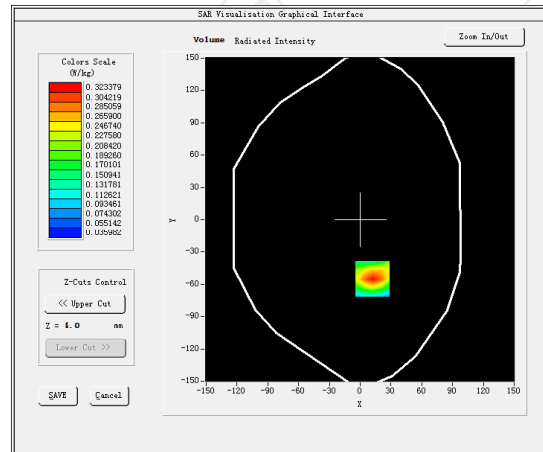

**Maximum location: X=12.00, Y=-55.00 SAR Peak: 0.45 W/kg**

**SAR 10g (W/Kg)**

0.182644

**SAR 1g (W/Kg)**

0.323078

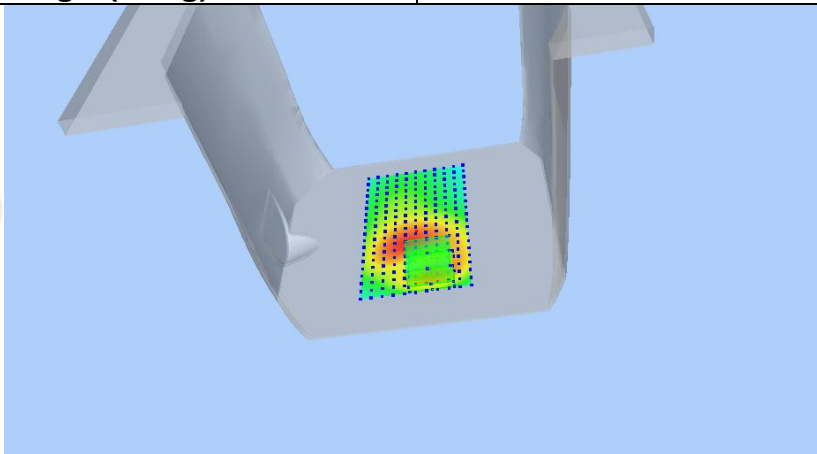

<b>Z (mm)</b>	<b>0.00</b>	<b>4.00</b>	<b>9.00</b>	<b>14.00</b>	<b>19.00</b>
<b>SAR (W/Kg)</b>	<b>0.4495</b>	<b>0.3234</b>	<b>0.2137</b>	<b>0.1437</b>	<b>0.0997</b>

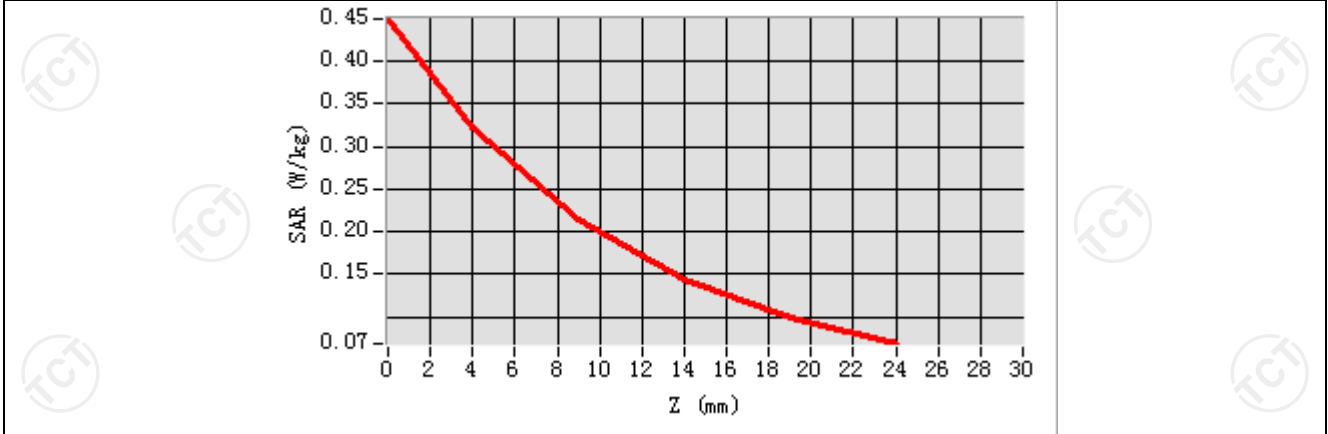

**Hot spot position**

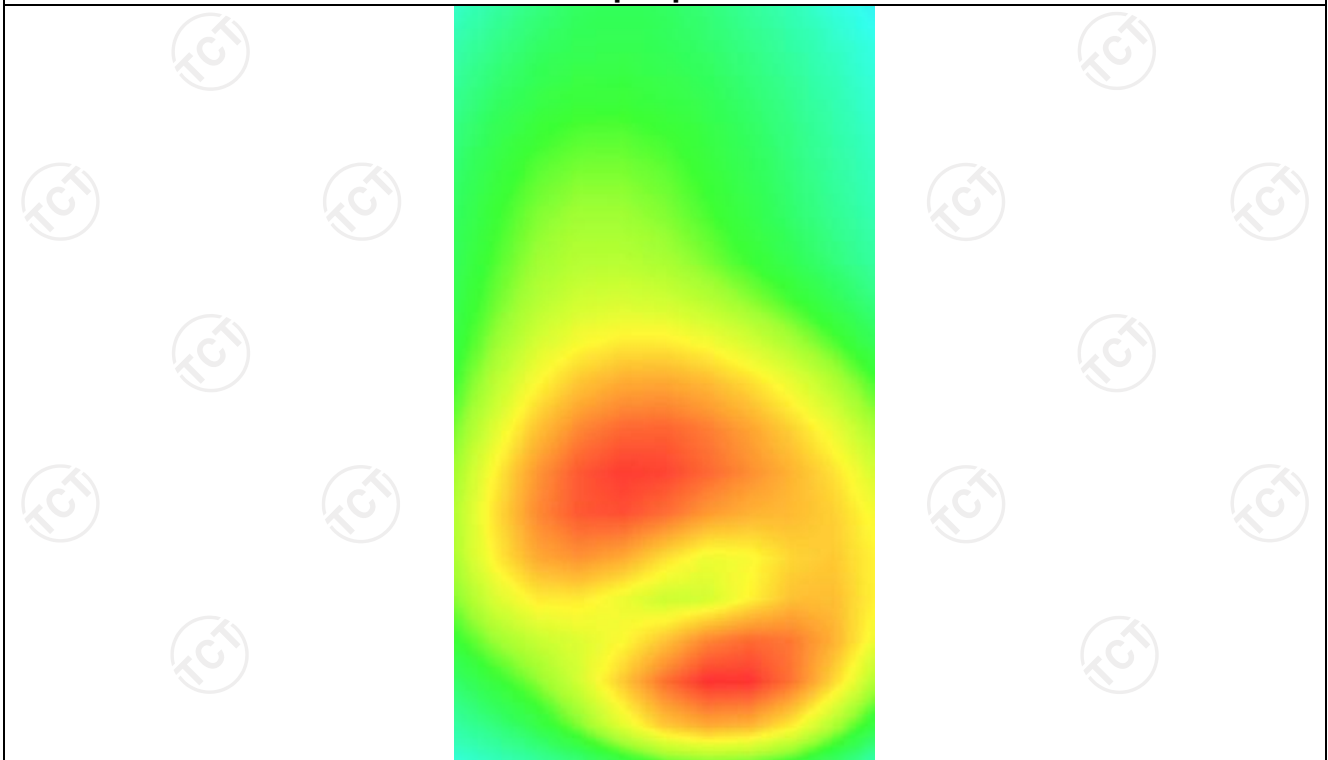

**MEASUREMENT 2**

Middle Band SAR (Channel 20525):

Date: 11/29/2021

<b>Frequency (MHz)</b>	836.500000
<b>Relative permittivity (real part)</b>	55.240832
<b>Relative permittivity (imaginary part)</b>	12.468860
<b>Conductivity (S/m)</b>	0.944272
<b>Variation (%)</b>	-1.090000
<b>Crest Factor</b>	1.0
<b>Probe Conversion factor</b>	1.78
<b>E-Field Probe:</b>	SSE2 (SN 36/20 EPG0346)
<b>Area Scan</b>	<u>dx=8mm dy=8mm, h= 5.00 mm</u>
<b>ZoomScan</b>	<u>5x5x7,dx=8mm dy=8mm</u> <u>dz=5mm,Complete/ndx=8mm dy=8mm, h=</u> <u>5.00 mm</u>
<b>Phantom</b>	<u>Validation plane</u>
<b>Device Position</b>	<u>Body back(10mm)</u>
<b>Band</b>	<u>LTE band 5(1 RB#24)</u>

**SURFACE SAR**

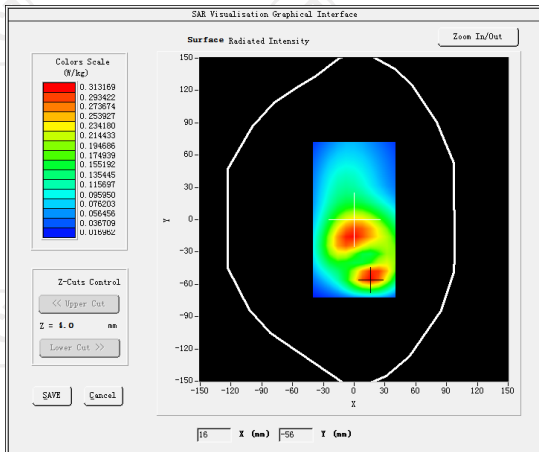

**VOLUME SAR**

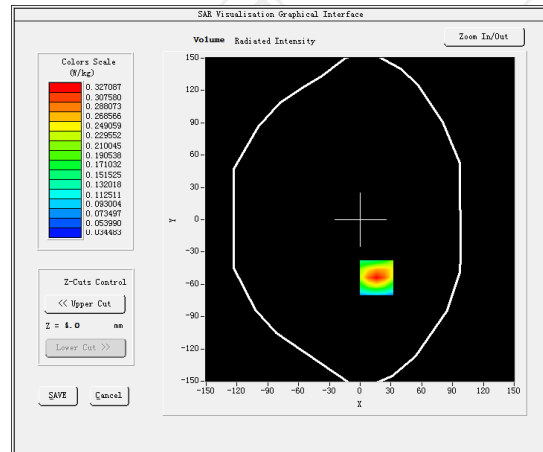

**Maximum location: X=-23.00, Y=-41.00 SAR Peak: 0.23 W/kg**

**SAR 10g (W/Kg)**

0.184888

**SAR 1g (W/Kg)**

0.347301

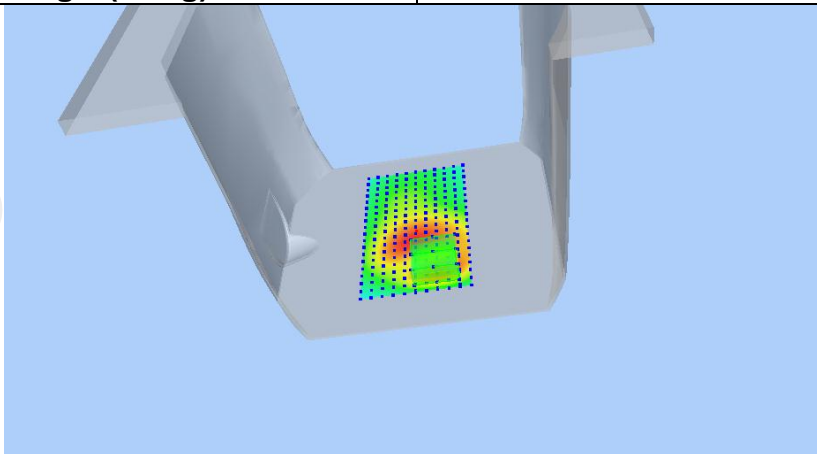

<b>Z (mm)</b>	<b>0.00</b>	<b>4.00</b>	<b>9.00</b>	<b>14.00</b>	<b>19.00</b>
<b>SAR (W/Kg)</b>	<b>0.4530</b>	<b>0.3271</b>	<b>0.2171</b>	<b>0.1465</b>	<b>0.1019</b>

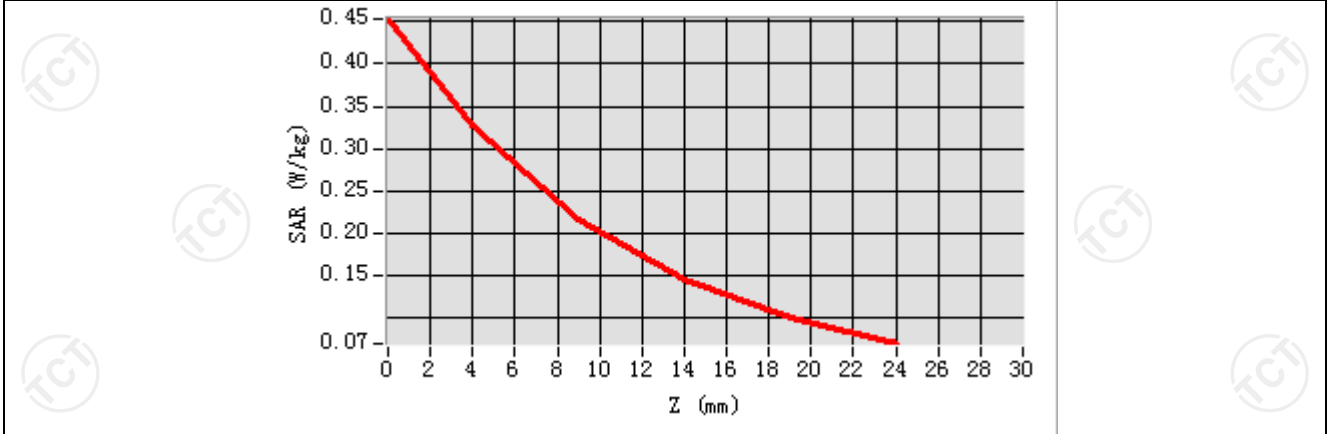

**Hot spot position**

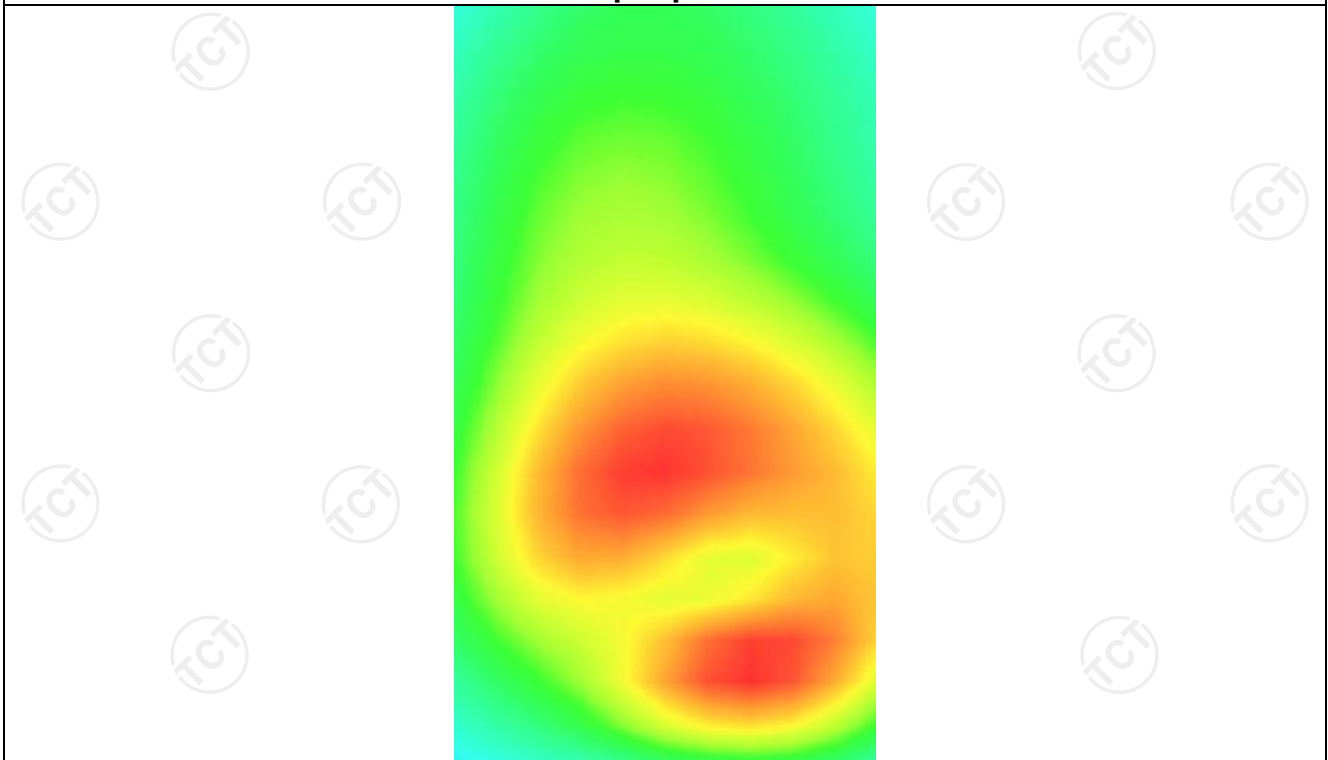

LTE Band 12

**MEASUREMENT 1**

Middle Band SAR (Channel 23095):

Date: 11/26/2021

<b>Frequency (MHz)</b>	707.500000
<b>Relative permittivity (real part)</b>	55.500832
<b>Relative permittivity (imaginary part)</b>	12.468860
<b>Conductivity (S/m)</b>	0.964272
<b>Variation (%)</b>	-1.160000
<b>Crest Factor</b>	1.0
<b>Probe Conversion factor</b>	1.78
<b>E-Field Probe:</b>	SSE2 (SN 36/20 EPG0346)
<b>Area Scan</b>	<u>dx=8mm dy=8mm, h= 5.00 mm</u>
<b>ZoomScan</b>	<u>5x5x7,dx=8mm dy=8mm</u> <u>dz=5mm,Complete/ndx=8mm dy=8mm, h=</u> <u>5.00 mm</u>
<b>Phantom</b>	<u>Validation plane</u>
<b>Device Position</b>	<u>Body back(10mm)</u>
<b>Band</b>	<u>LTE band 12(1 RB#24)</u>

**SURFACE SAR**

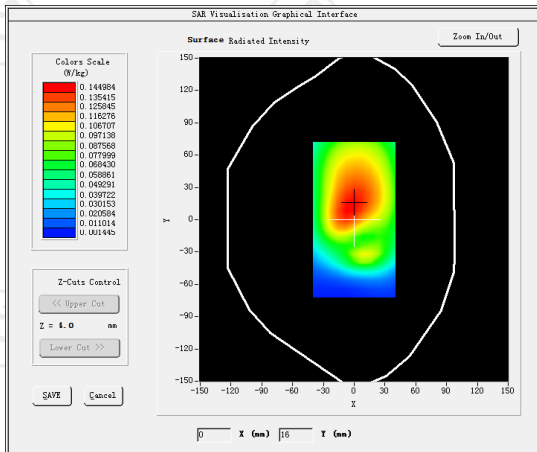

**VOLUME SAR**

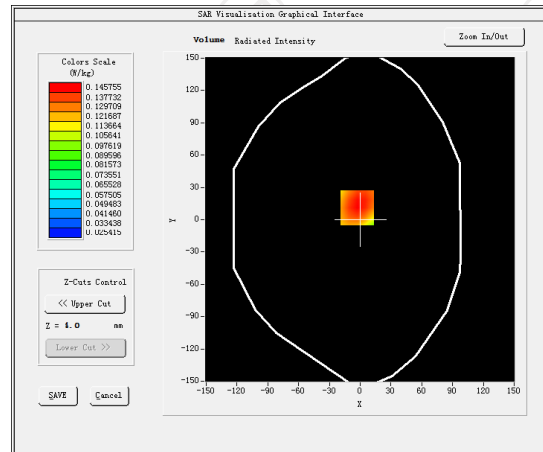

**Maximum location: X=-3.00, Y=11.00 SAR Peak: 0.17 W/kg**

**SAR 10g (W/Kg)**

0.108746

**SAR 1g (W/Kg)**

0.141547

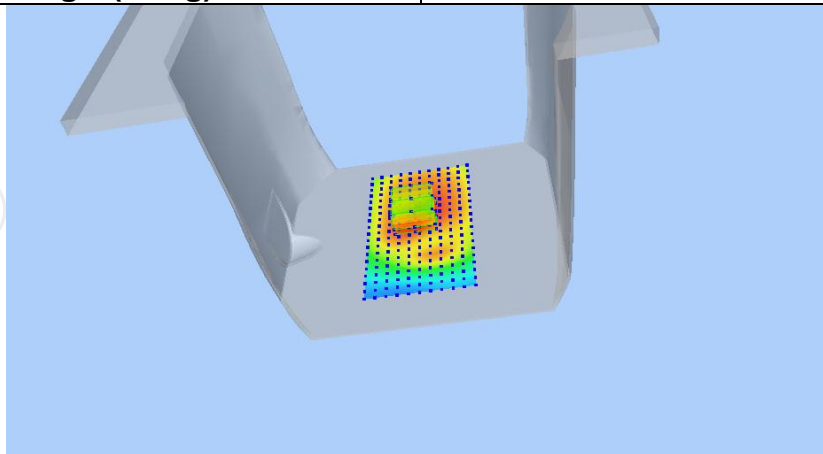



<b>Z (mm)</b>	<b>0.00</b>	<b>4.00</b>	<b>9.00</b>	<b>14.00</b>	<b>19.00</b>
<b>SAR (W/Kg)</b>	<b>0.1728</b>	<b>0.1458</b>	<b>0.1169</b>	<b>0.0930</b>	<b>0.0732</b>

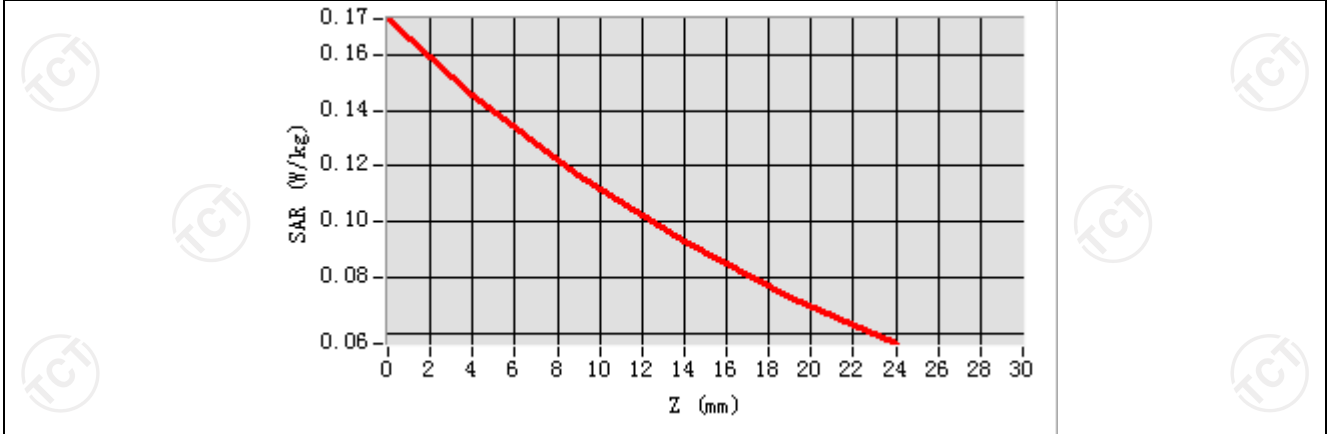

**Hot spot position**

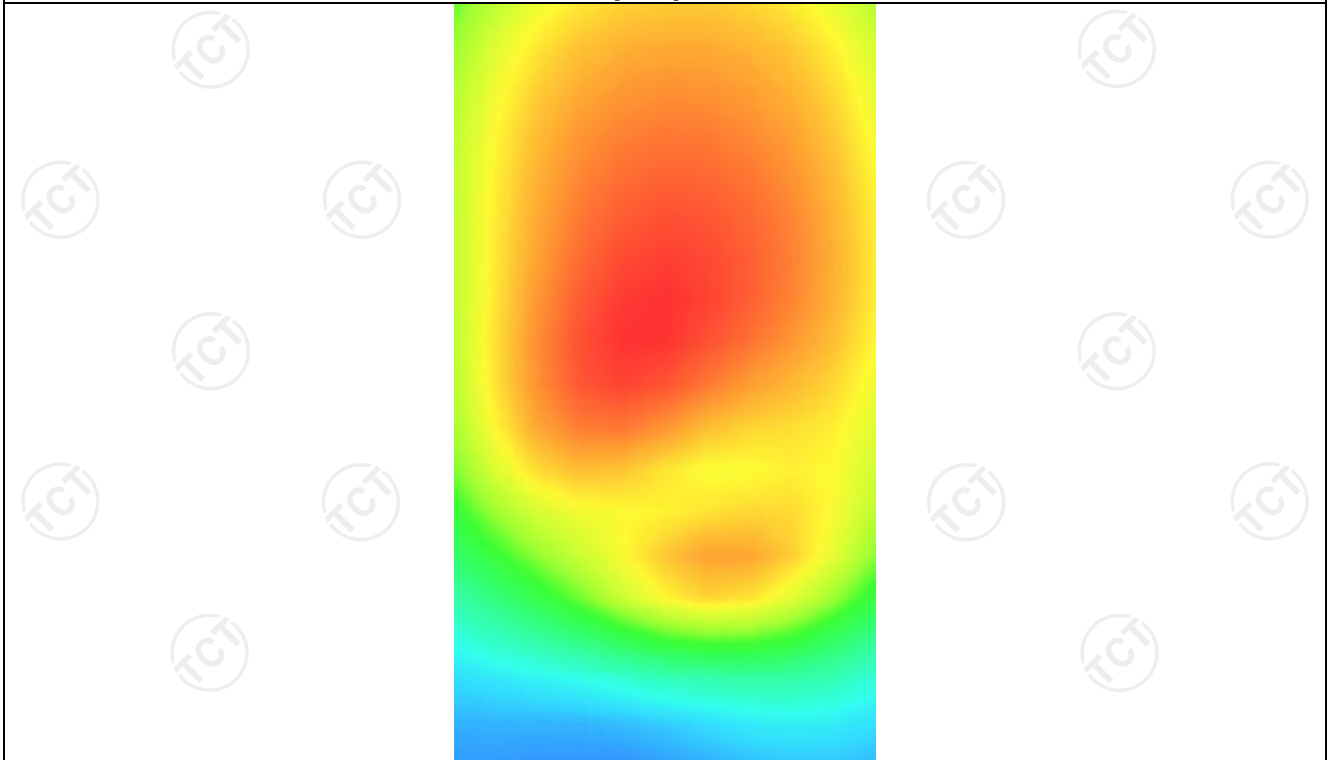

**MEASUREMENT 2**

Middle Band SAR (Channel 23095):

Date: 11/26/2021

<b>Frequency (MHz)</b>	707.500000
<b>Relative permittivity (real part)</b>	55.500832
<b>Relative permittivity (imaginary part)</b>	12.468860
<b>Conductivity (S/m)</b>	0.964272
<b>Variation (%)</b>	-0.460000
<b>Crest Factor</b>	1.0
<b>Probe Conversion factor</b>	1.78
<b>E-Field Probe:</b>	SSE2 (SN 36/20 EPG0346)
<b>Area Scan</b>	<u>dx=8mm dy=8mm, h= 5.00 mm</u>
<b>ZoomScan</b>	<u>5x5x7, dx=8mm dy=8mm</u> <u>dz=5mm, Complete/ndx=8mm dy=8mm, h=</u> <u>5.00 mm</u>
<b>Phantom</b>	<u>Validation plane</u>
<b>Device Position</b>	<u>Body back(hotspot 10mm)</u>
<b>Band</b>	<u>LTE band 12(1 RB#24)</u>

**SURFACE SAR**

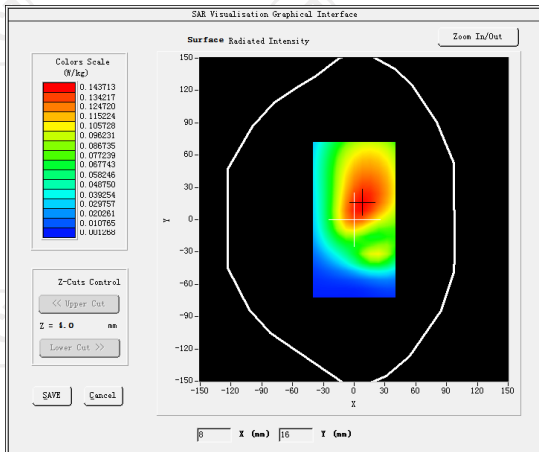

**VOLUME SAR**

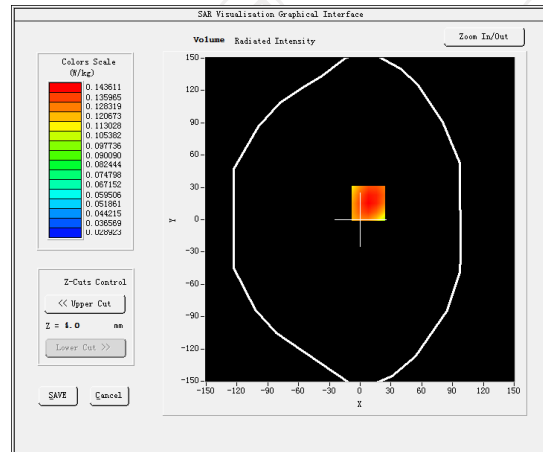

**Maximum location: X=8.00, Y=15.00 SAR Peak: 0.17 W/kg**

**SAR 10g (W/Kg)**

0.108025

**SAR 1g (W/Kg)**

0.159366

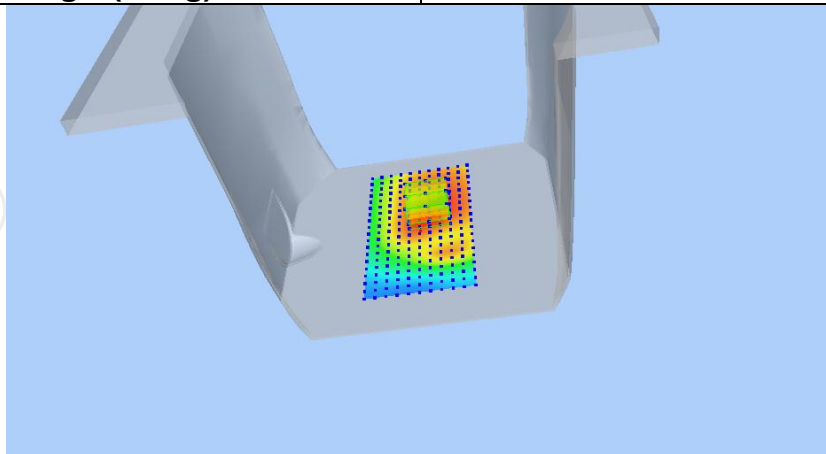

<b>Z (mm)</b>	<b>0.00</b>	<b>4.00</b>	<b>9.00</b>	<b>14.00</b>	<b>19.00</b>
<b>SAR (W/Kg)</b>	<b>0.1693</b>	<b>0.1436</b>	<b>0.1162</b>	<b>0.0936</b>	<b>0.0747</b>

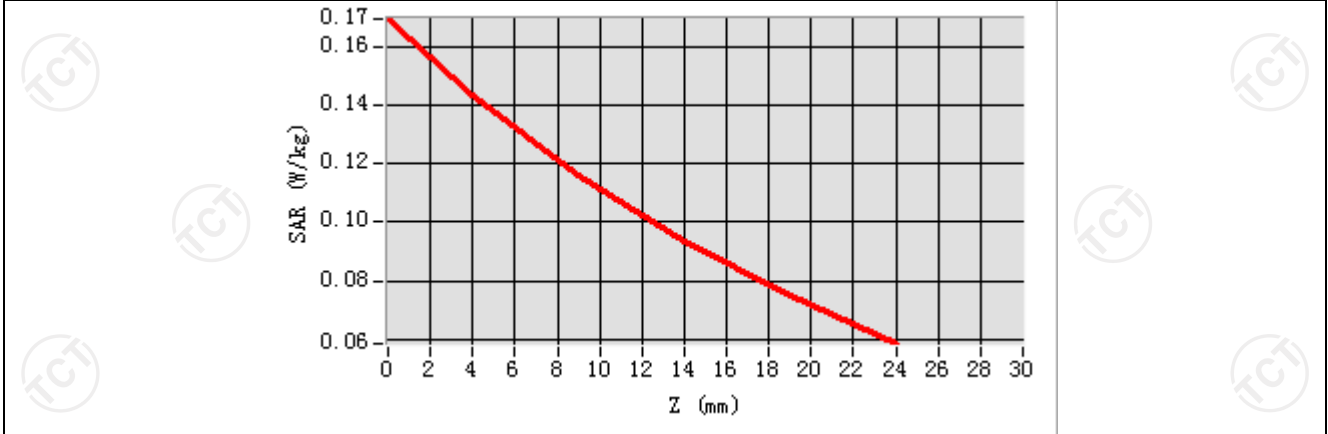

**Hot spot position**

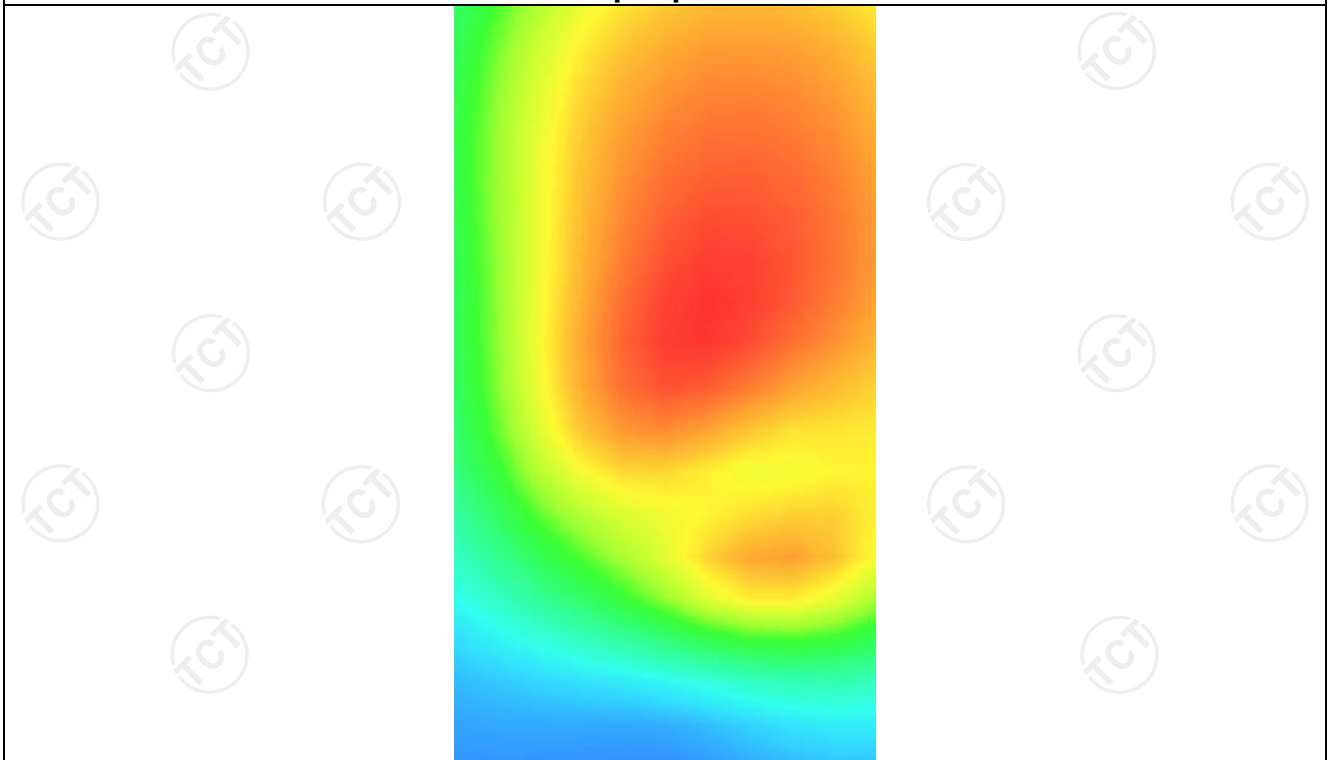

LTE Band 17

**MEASUREMENT 1**

Lower Band SAR (Channel 23780):

Date: 11/26/2021

<b>Frequency (MHz)</b>	709.000000
<b>Relative permittivity (real part)</b>	55.503812
<b>Relative permittivity (imaginary part)</b>	12.468867
<b>Conductivity (S/m)</b>	0.960822
<b>Variation (%)</b>	-1.360000
<b>Crest Factor</b>	1.0
<b>Probe Conversion factor</b>	1.78
<b>E-Field Probe:</b>	SSE2 (SN 36/20 EPG0346)
<b>Area Scan</b>	<u>dx=8mm dy=8mm, h= 5.00 mm</u>
<b>ZoomScan</b>	<u>5x5x7,dx=8mm dy=8mm</u> <u>dz=5mm,Complete/ndx=8mm dy=8mm, h=</u> <u>5.00 mm</u>
<b>Phantom</b>	<u>Validation plane</u>
<b>Device Position</b>	<u>Body back(10mm)</u>
<b>Band</b>	<u>LTE band 17(1 RB#24)</u>

**SURFACE SAR**

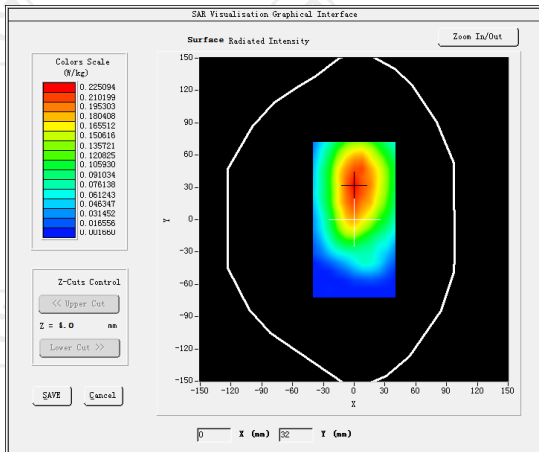

**VOLUME SAR**

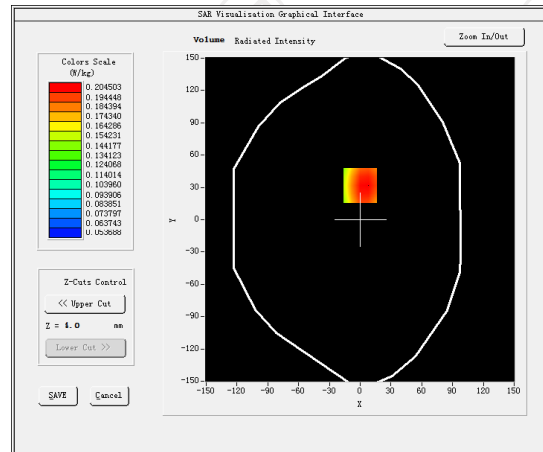

**Maximum location: X=0.00, Y=32.00 SAR Peak: 0.23 W/kg**

<b>SAR 10g (W/Kg)</b>	0.163761
<b>SAR 1g (W/Kg)</b>	0.211528

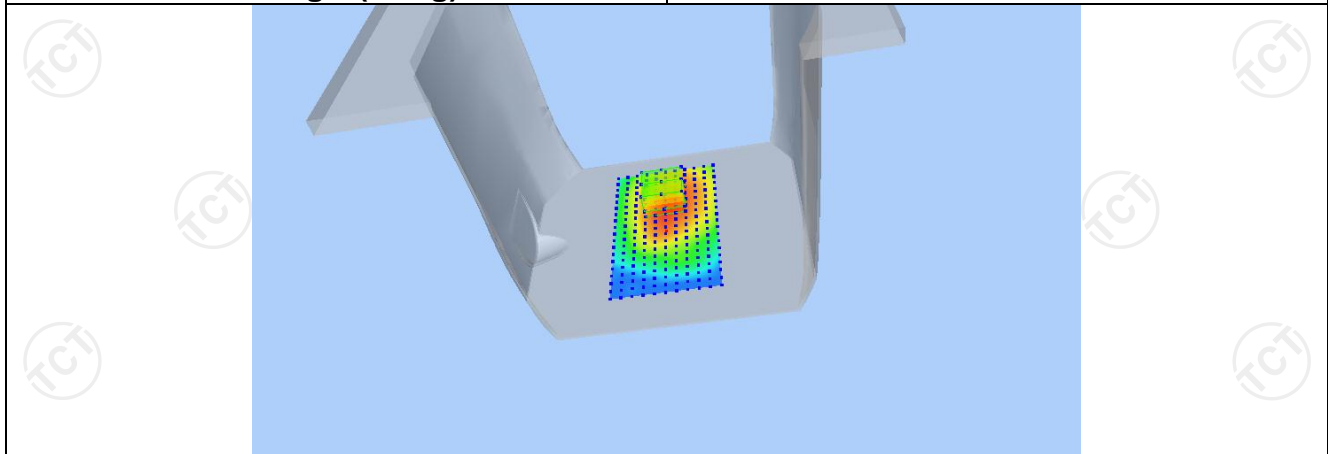

<b>Z (mm)</b>	<b>0.00</b>	<b>4.00</b>	<b>9.00</b>	<b>14.00</b>	<b>19.00</b>
<b>SAR (W/Kg)</b>	<b>0.2255</b>	<b>0.2037</b>	<b>0.1731</b>	<b>0.1402</b>	<b>0.1071</b>

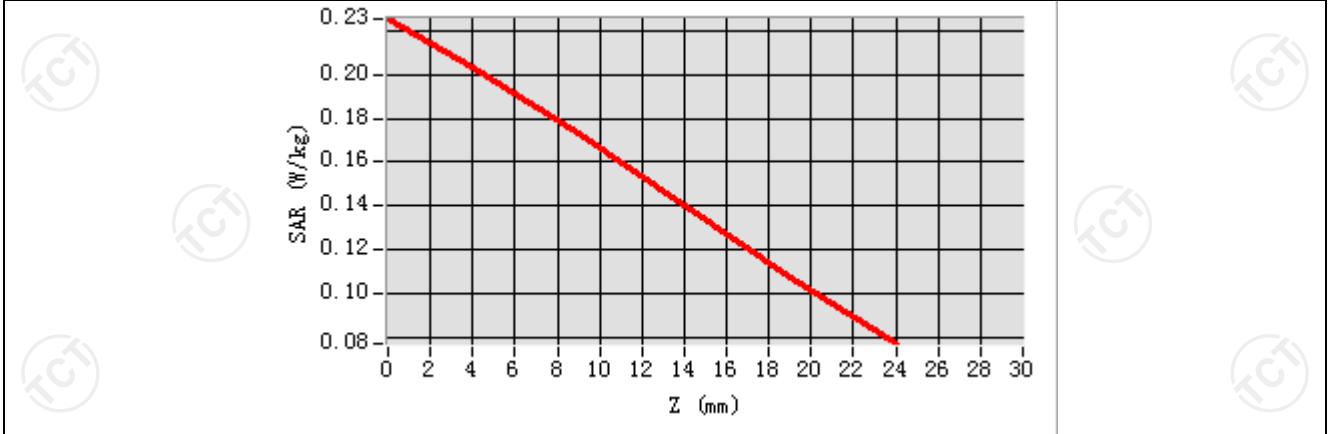

**Hot spot position**

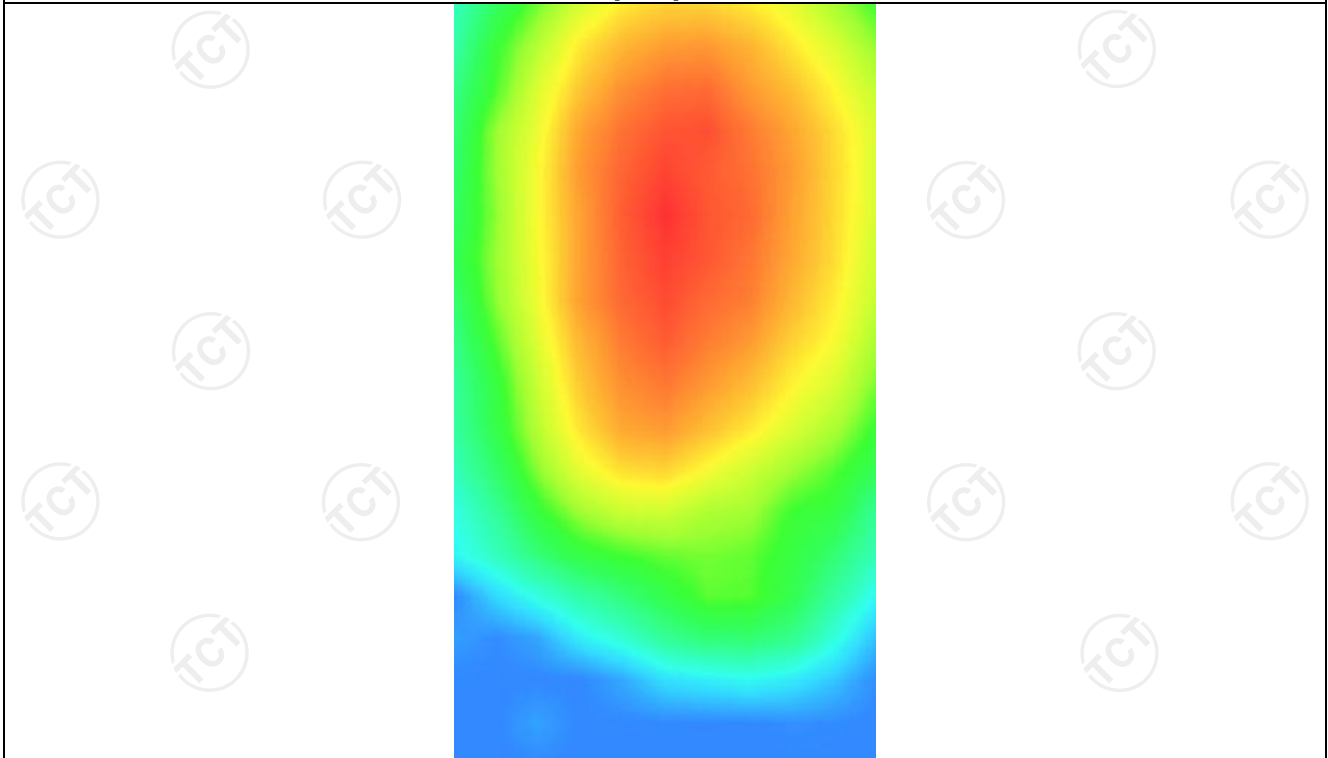

**MEASUREMENT 2**

Lower Band SAR (Channel 23780):

Date: 11/26/2021

Frequency (MHz)	709.000000
Relative permittivity (real part)	55.503812
Relative permittivity (imaginary part)	12.468867
Conductivity (S/m)	0.961392
Variation (%)	3.610000
Crest Factor	1.0
Probe Conversion factor	1.78
E-Field Probe:	SSE2 (SN 36/20 EPG0346)
Area Scan	<u>dx=8mm dy=8mm, h= 5.00 mm</u>
ZoomScan	<u>5x5x7,dx=8mm dy=8mm</u> <u>dz=5mm,Complete/ndx=8mm dy=8mm, h=</u> <u>5.00 mm</u>
Phantom	<u>Validation plane</u>
Device Position	<u>Body back(hotspot 10mm)</u>
Band	<u>LTE band 17(1 RB#24)</u>

**SURFACE SAR**

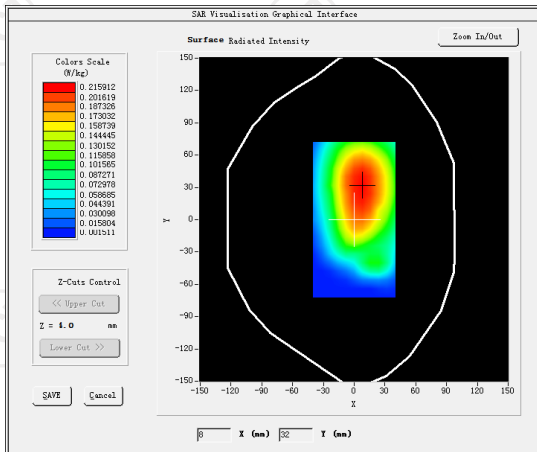

**VOLUME SAR**

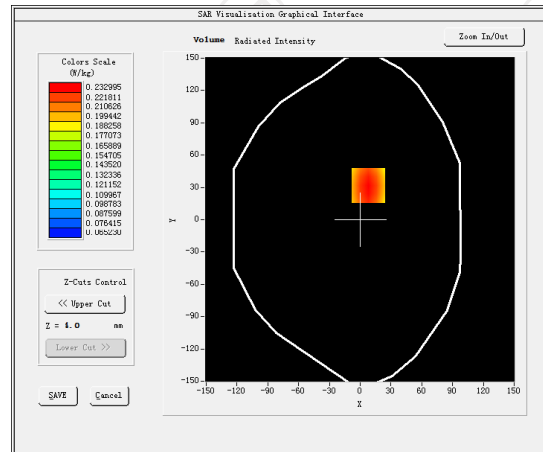

**Maximum location: X=8.00, Y=32.00 SAR Peak: 0.29 W/kg**

**SAR 10g (W/Kg)**

0.174627

**SAR 1g (W/Kg)**

0.238358

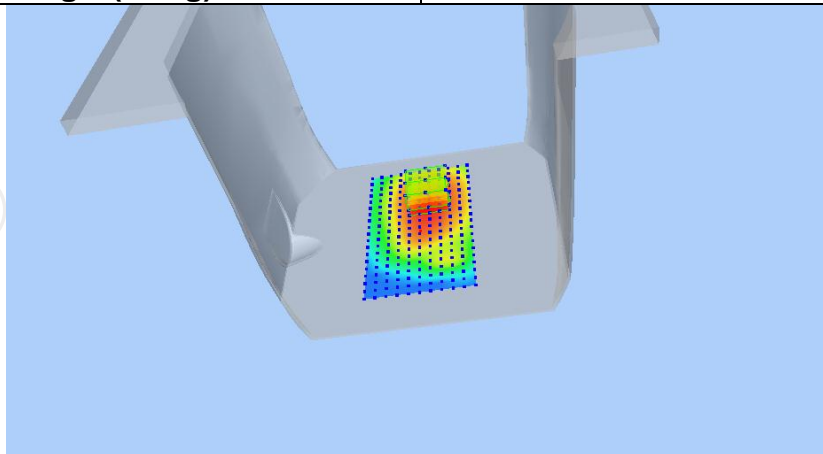

<b>Z (mm)</b>	<b>0.00</b>	<b>4.00</b>	<b>9.00</b>	<b>14.00</b>	<b>19.00</b>
<b>SAR (W/Kg)</b>	<b>0.2934</b>	<b>0.2330</b>	<b>0.1761</b>	<b>0.1359</b>	<b>0.1077</b>

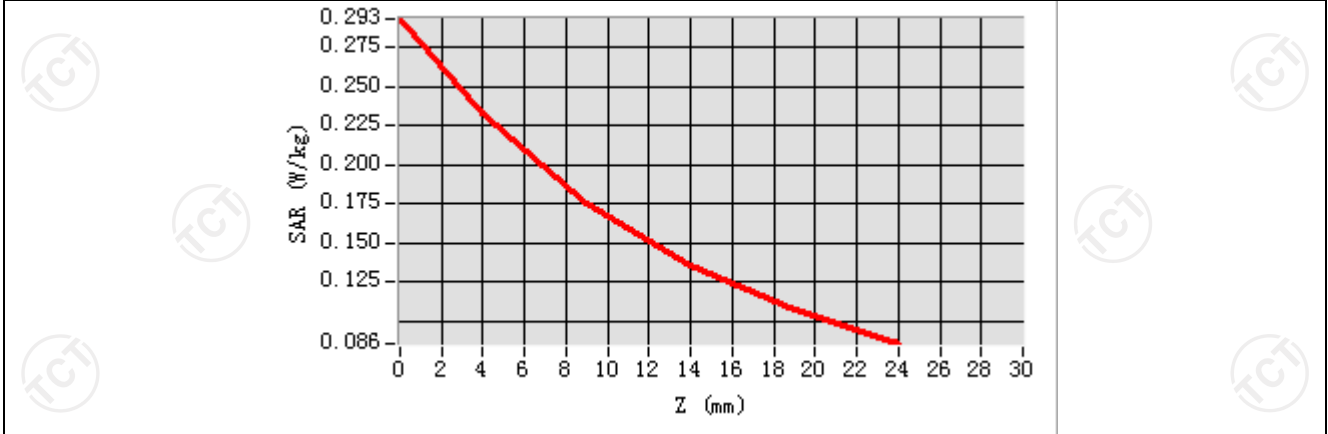

**Hot spot position**

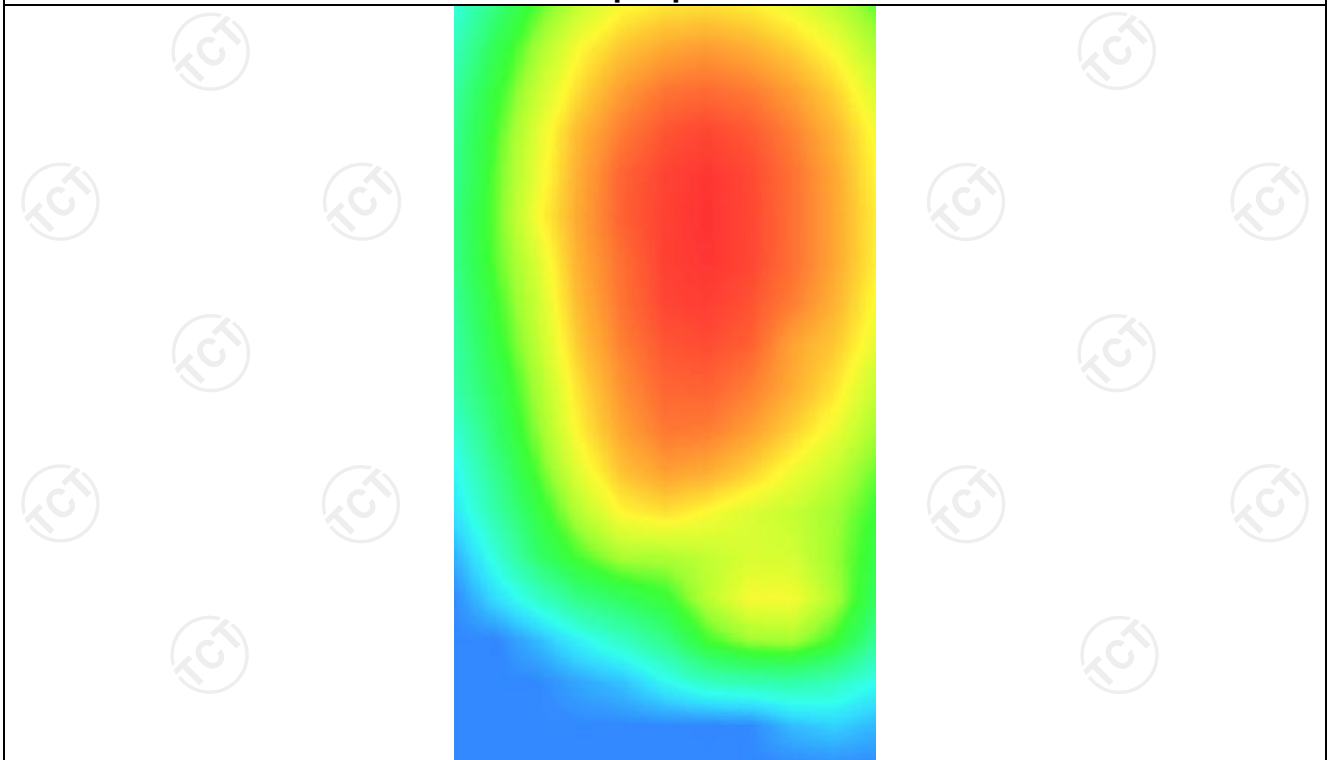

WLAN 2.4G

**MEASUREMENT 1**

Lower Band SAR (Channel 03):

Date: 12/13/2021

<b>Frequency (MHz)</b>	2422.00000
<b>Relative permittivity (real part)</b>	54.632146
<b>Relative permittivity (imaginary part)</b>	14.318285
<b>Conductivity (S/m)</b>	1.983842
<b>Variation (%)</b>	-0.710000
<b>Crest Factor</b>	1.0
<b>Probe Conversion factor</b>	2.37
<b>E-Field Probe:</b>	SSE2 (SN 36/20 EPG0346)
<b>Area Scan</b>	<u>dx=8mm dy=8mm, h= 5.00 mm</u>
<b>ZoomScan</b>	<u>5x5x7, dx=8mm dy=8mm</u> <u>dz=5mm, Complete/ndx=8mm dy=8mm, h=</u> <u>5.00 mm</u>
<b>Phantom</b>	Validation plane
<b>Device Position</b>	Body back(10mm)
<b>Band</b>	<u>IEEE 802.11n HT40 ISM</u>

**SURFACE SAR**

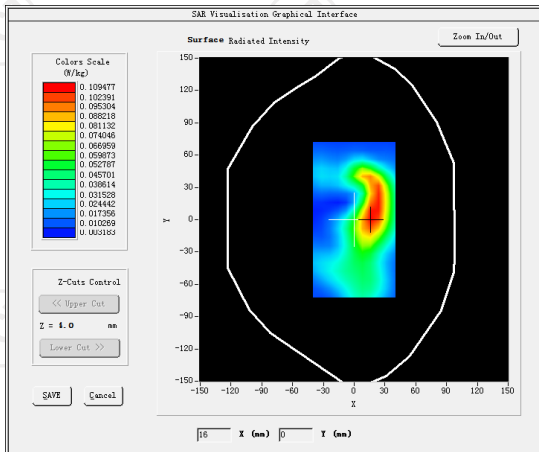

**VOLUME SAR**

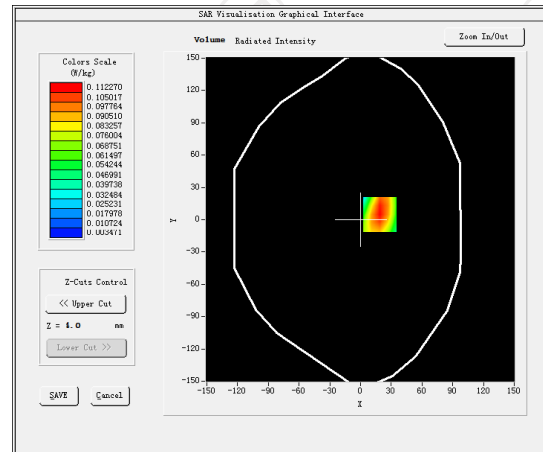

**Maximum location: X=19.00, Y=5.00 SAR Peak: 0.39 W/kg**

<b>SAR 10g (W/Kg)</b>	0.068895
<b>SAR 1g (W/Kg)</b>	0.229565

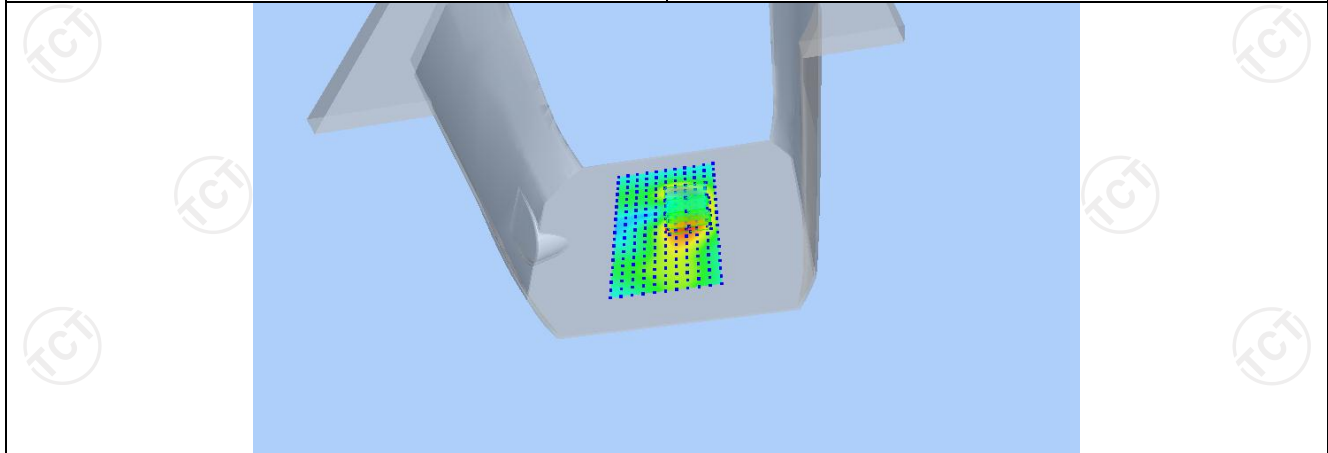



<b>Z (mm)</b>	<b>0.00</b>	<b>4.00</b>	<b>9.00</b>	<b>14.00</b>	<b>19.00</b>
<b>SAR (W/Kg)</b>	<b>0.3880</b>	<b>0.2293</b>	<b>0.1129</b>	<b>0.0549</b>	<b>0.0281</b>

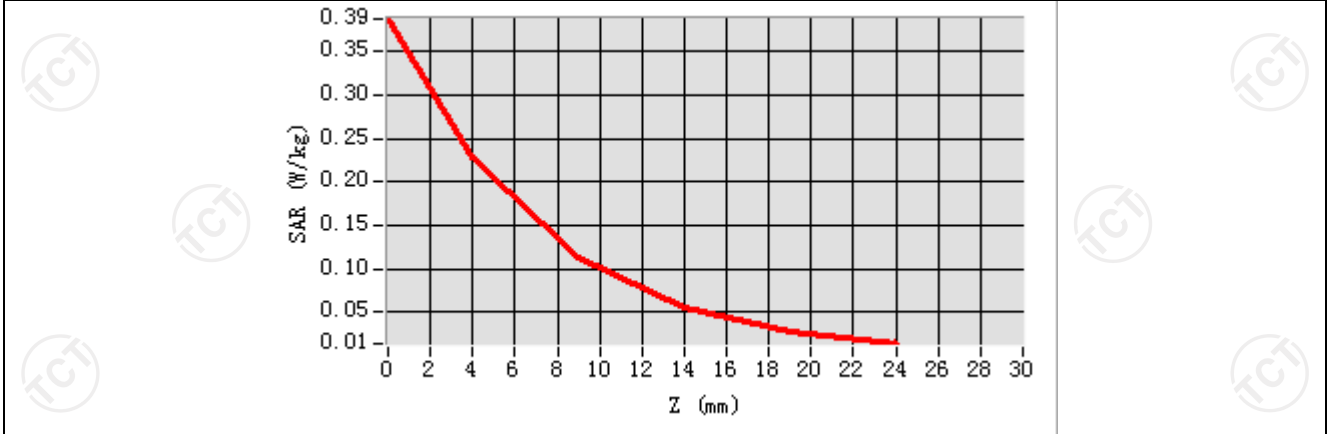

**Hot spot position**

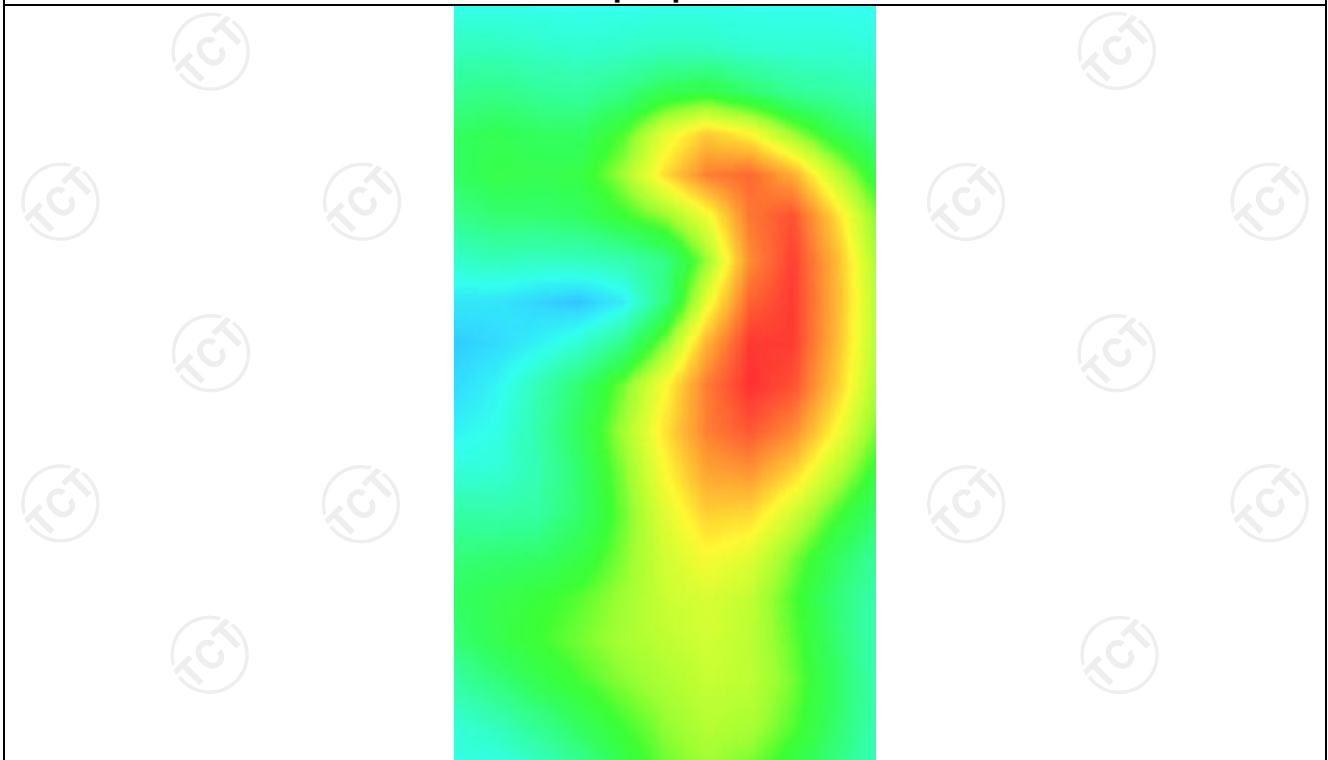

**MEASUREMENT 2**

Lower Band SAR (Channel 03):

Date: 12/13/2021

<b>Frequency (MHz)</b>	2422.00000
<b>Relative permittivity (real part)</b>	54.632146
<b>Relative permittivity (imaginary part)</b>	14.318285
<b>Conductivity (S/m)</b>	1.983842
<b>Variation (%)</b>	-1.450000
<b>Crest Factor</b>	1.0
<b>Probe Conversion factor</b>	2.37
<b>E-Field Probe:</b>	SSE2 (SN 36/20 EPG0346)
<b>Area Scan</b>	<u>dx=8mm dy=8mm, h= 5.00 mm</u>
<b>ZoomScan</b>	<u>5x5x7,dx=8mm dy=8mm</u> <u>dz=5mm,Complete/ndx=8mm dy=8mm, h=</u> <u>5.00 mm</u>
<b>Phantom</b>	Validation plane
<b>Device Position</b>	Body back(10mm)
<b>Band</b>	<u>IEEE 802.11n HT40 ISM (hotspot)</u>

**SURFACE SAR**

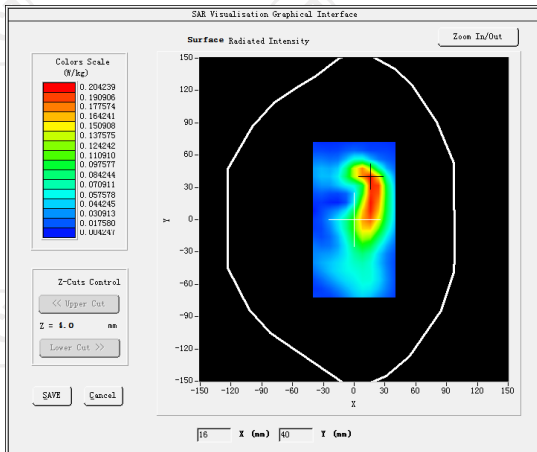

**VOLUME SAR**

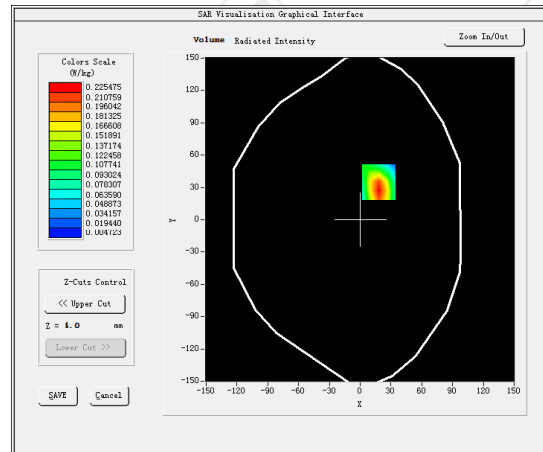

**Maximum location: X=18.00, Y=35.00 SAR Peak: 0.39 W/kg**

**SAR 10g (W/Kg)**

0.098645

**SAR 1g (W/Kg)**

0.244300

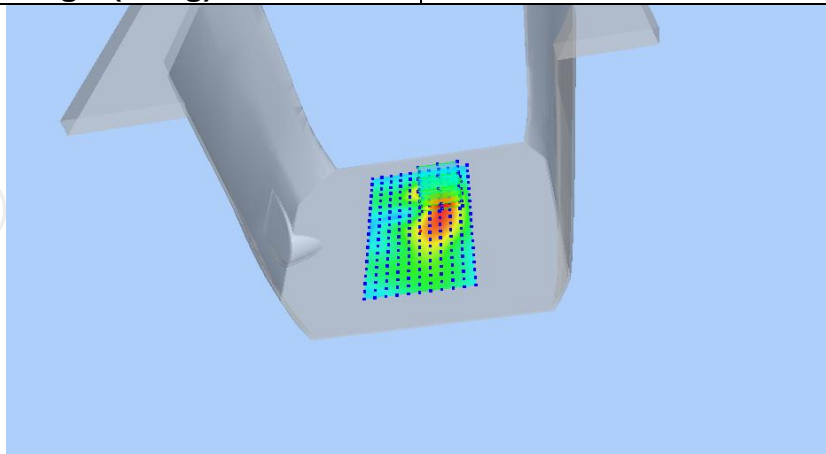

<b>Z (mm)</b>	<b>0.00</b>	<b>4.00</b>	<b>9.00</b>	<b>14.00</b>	<b>19.00</b>
<b>SAR (W/Kg)</b>	<b>0.3683</b>	<b>0.2119</b>	<b>0.1003</b>	<b>0.0468</b>	<b>0.0235</b>

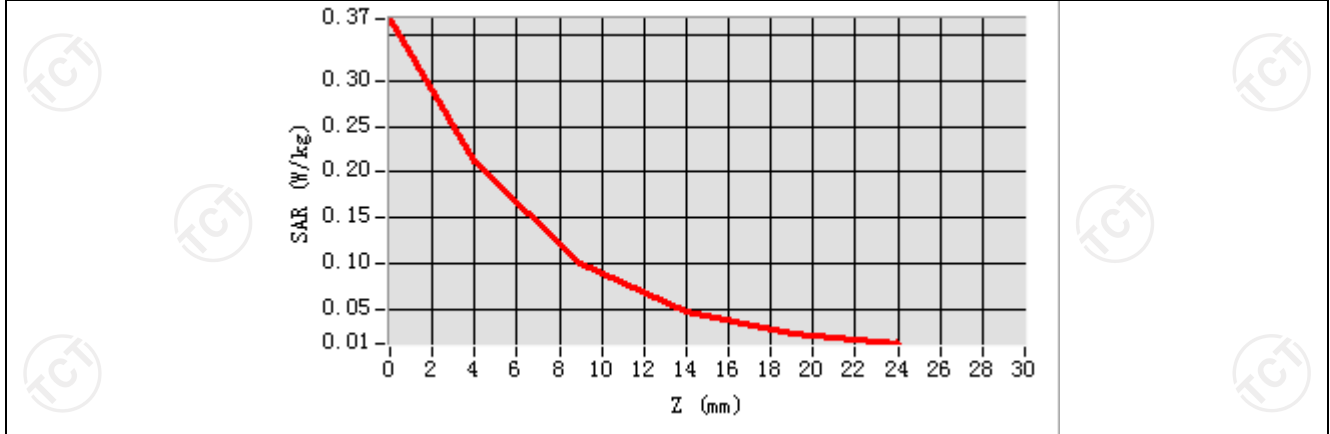

**Hot spot position**

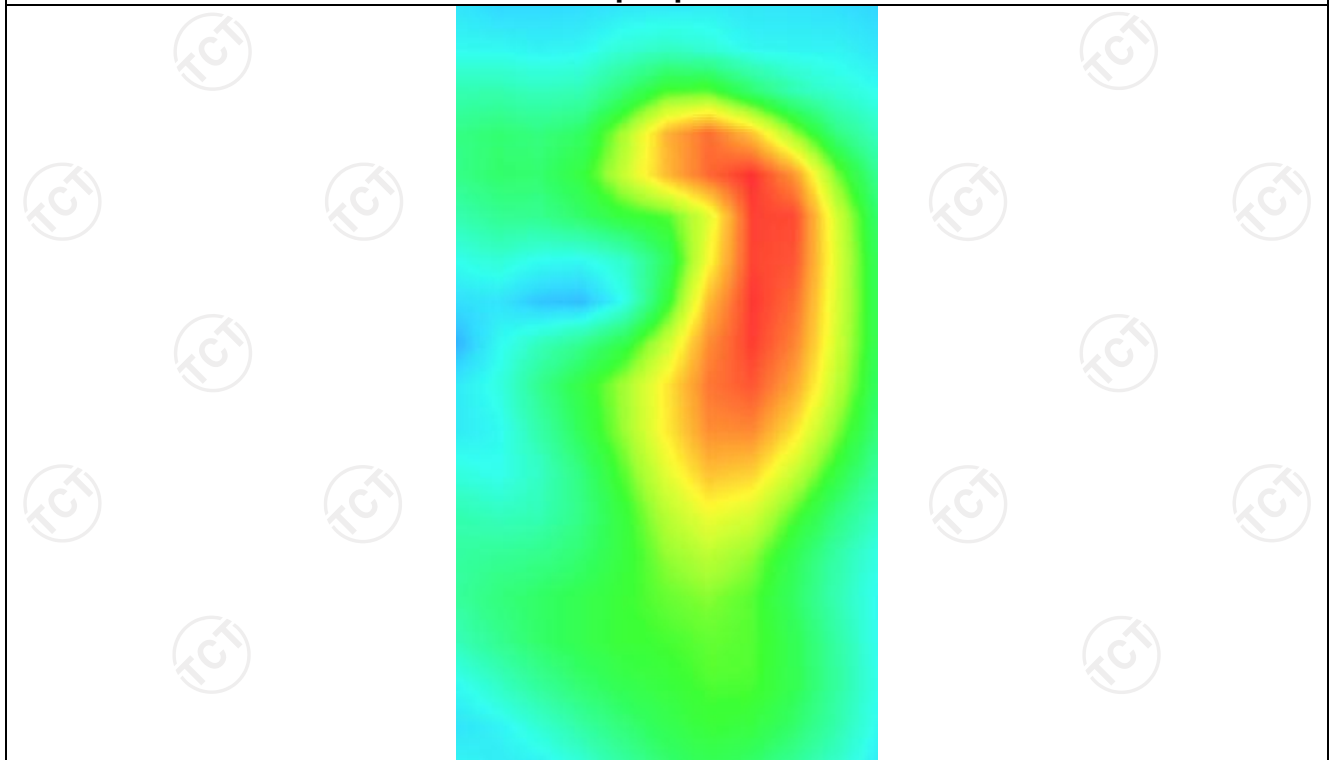

WLAN 5.2G

**MEASUREMENT 1**

SAR (Channel 36):

Date: 12/14/2021

<b>Frequency (MHz)</b>	5180.000000
<b>Relative permittivity (real part)</b>	49.022077
<b>Relative permittivity (imaginary part)</b>	21.378187
<b>Conductivity (S/m)</b>	5.458883
<b>Variation (%)</b>	-0.550000
<b>Crest Factor</b>	1.0
<b>Probe Conversion factor</b>	2.08
<b>E-Field Probe:</b>	SSE2 (SN 36/20 EPGO346)
<b>Area Scan</b>	<u>dx=8mm dy=8mm, h= 5.00 mm</u>
<b>ZoomScan</b>	<u>5x5x7, dx=8mm dy=8mm</u> <u>dz=5mm, Complete/ndx=8mm dy=8mm, h=</u> <u>5.00 mm</u>
<b>Phantom</b>	Validation plane
<b>Device Position</b>	Body back(10mm)
<b>Band</b>	<u>IEEE 802.11ac HT20 ISM</u>

**SURFACE SAR**

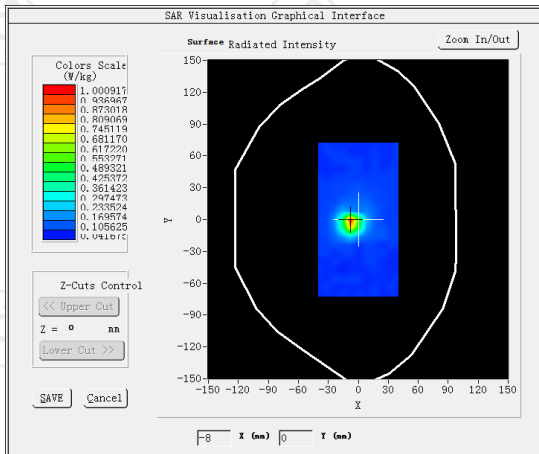

**VOLUME SAR**

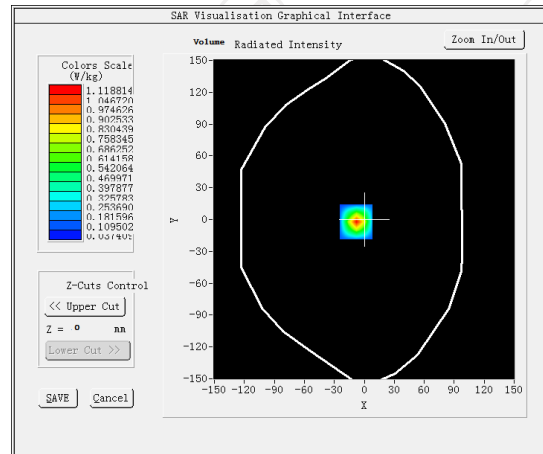

**Maximum location: X=-8.00, Y=-2.00 SAR Peak: 1.88 W/kg**

**SAR 10g (W/Kg)**

0.245356

**SAR 1g (W/Kg)**

0.331034

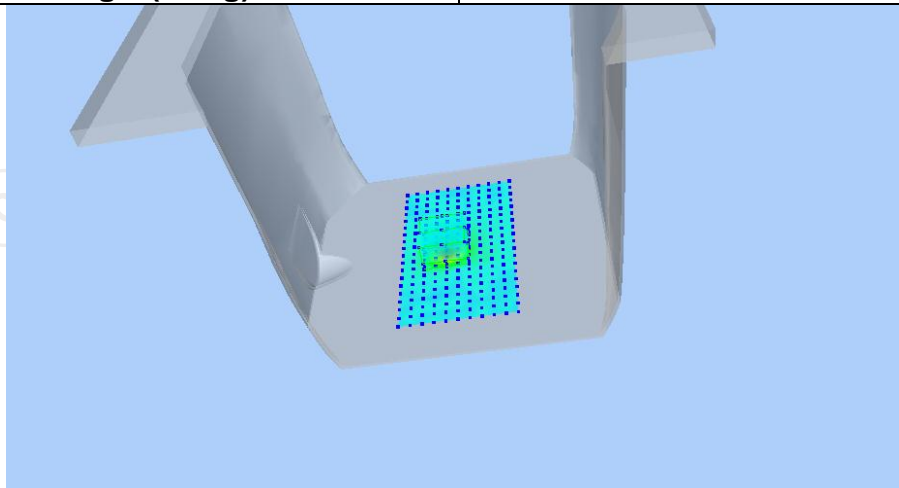

<b>Z (mm)</b>	<b>0.00</b>	<b>2.00</b>	<b>7.00</b>	<b>12.00</b>	<b>17.00</b>
<b>SAR (W/Kg)</b>	<b>1.8200</b>	<b>1.1188</b>	<b>0.2558</b>	<b>0.0533</b>	<b>0.0374</b>

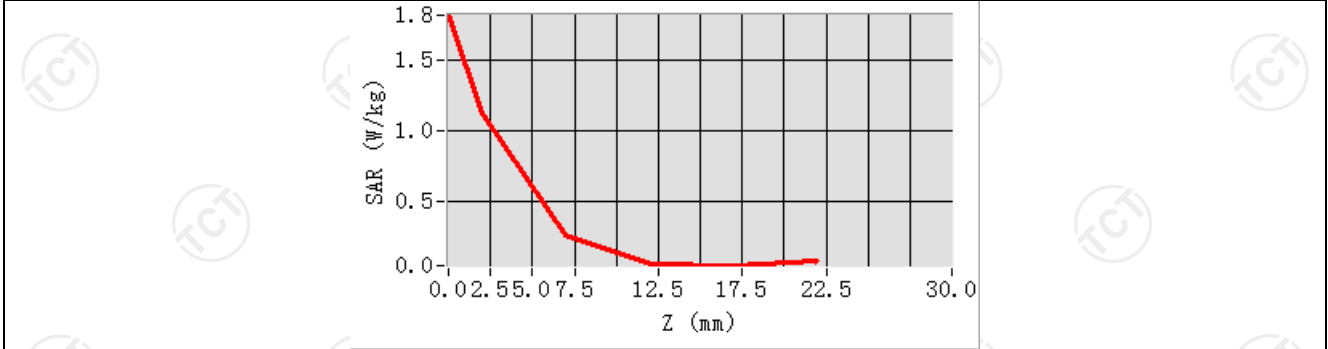

**Hot spot position**

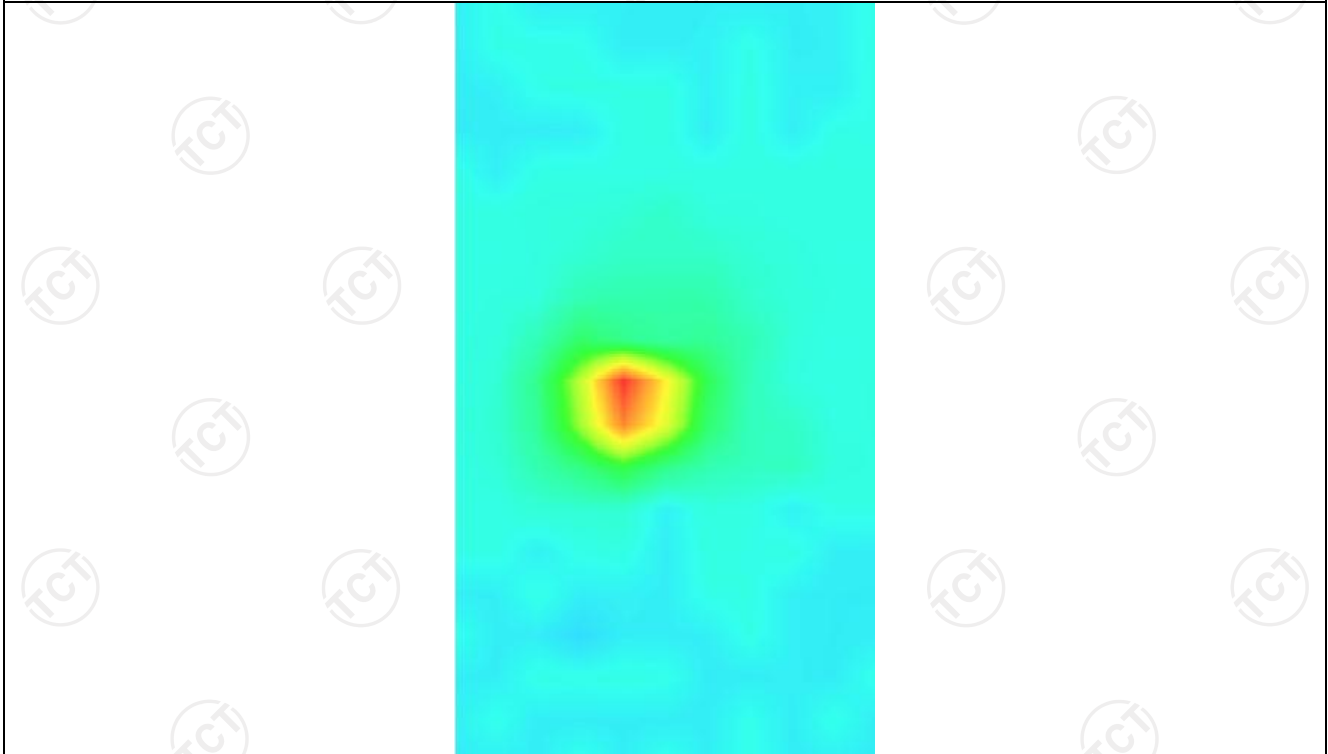

**MEASUREMENT 2**

SAR (Channel 36):

Date: 12/14/2021

<b>Frequency (MHz)</b>	5180.000000
<b>Relative permittivity (real part)</b>	50.022077
<b>Relative permittivity (imaginary part)</b>	21.378187
<b>Conductivity (S/m)</b>	5.458883
<b>Variation (%)</b>	-3.530000
<b>Crest Factor</b>	1.0
<b>Probe Conversion factor</b>	2.08
<b>E-Field Probe:</b>	SSE2 (SN 36/20 EPG0346)
<b>Area Scan</b>	<u>dx=8mm dy=8mm, h= 5.00 mm</u>
<b>ZoomScan</b>	<u>5x5x7, dx=8mm dy=8mm</u> <u>dz=5mm, Complete/ndx=8mm dy=8mm, h=</u> <u>5.00 mm</u>
<b>Phantom</b>	Validation plane
<b>Device Position</b>	Body back(10mm)
<b>Band</b>	<u>IEEE 802.11ac HT20 ISM(hotspot)</u>

**SURFACE SAR**

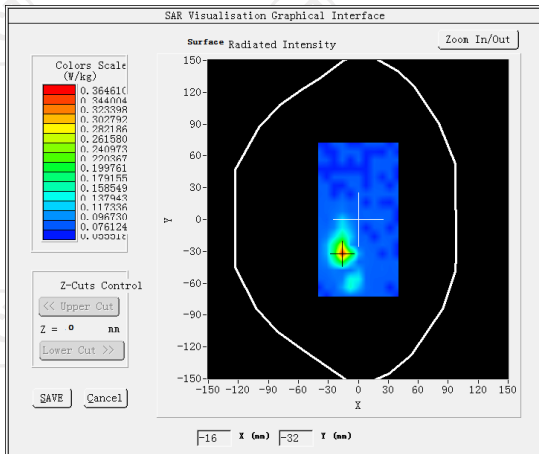

**VOLUME SAR**

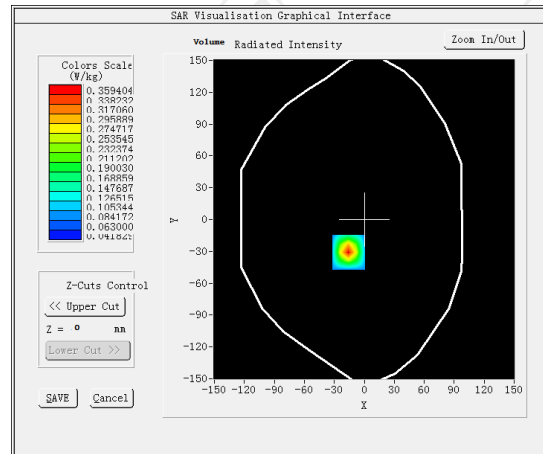

**Maximum location: X=-16.00, Y=-31.00 SAR Peak: 0.55 W/kg**

**SAR 10g (W/Kg)**

0.115867

**SAR 1g (W/Kg)**

0.347908

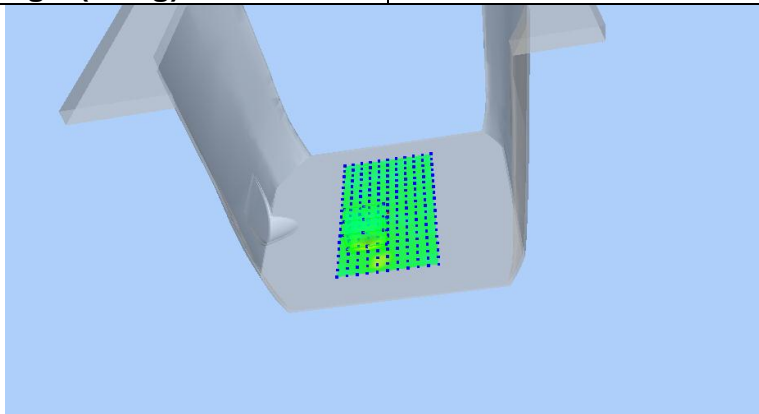

<b>Z (mm)</b>	<b>0.00</b>	<b>2.00</b>	<b>7.00</b>	<b>12.00</b>	<b>17.00</b>
<b>SAR (W/Kg)</b>	<b>0.5348</b>	<b>0.3594</b>	<b>0.1222</b>	<b>0.0501</b>	<b>0.0418</b>

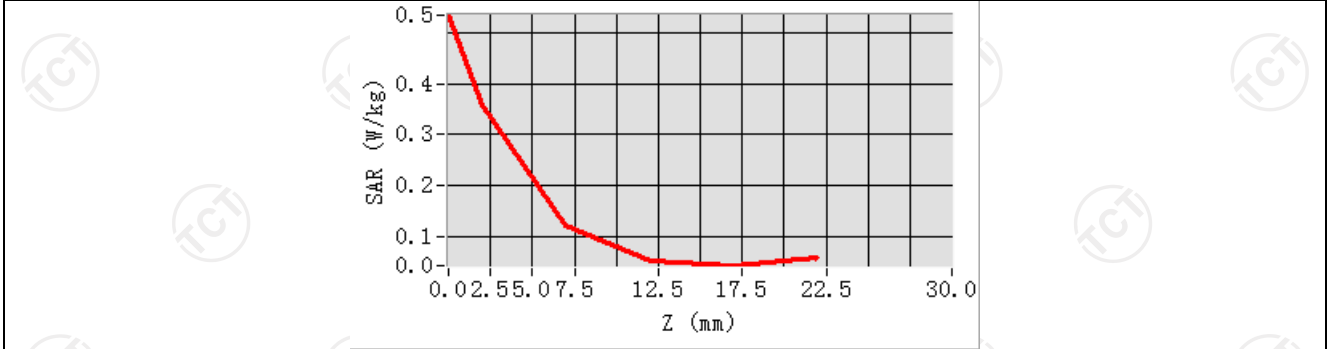

**Hot spot position**

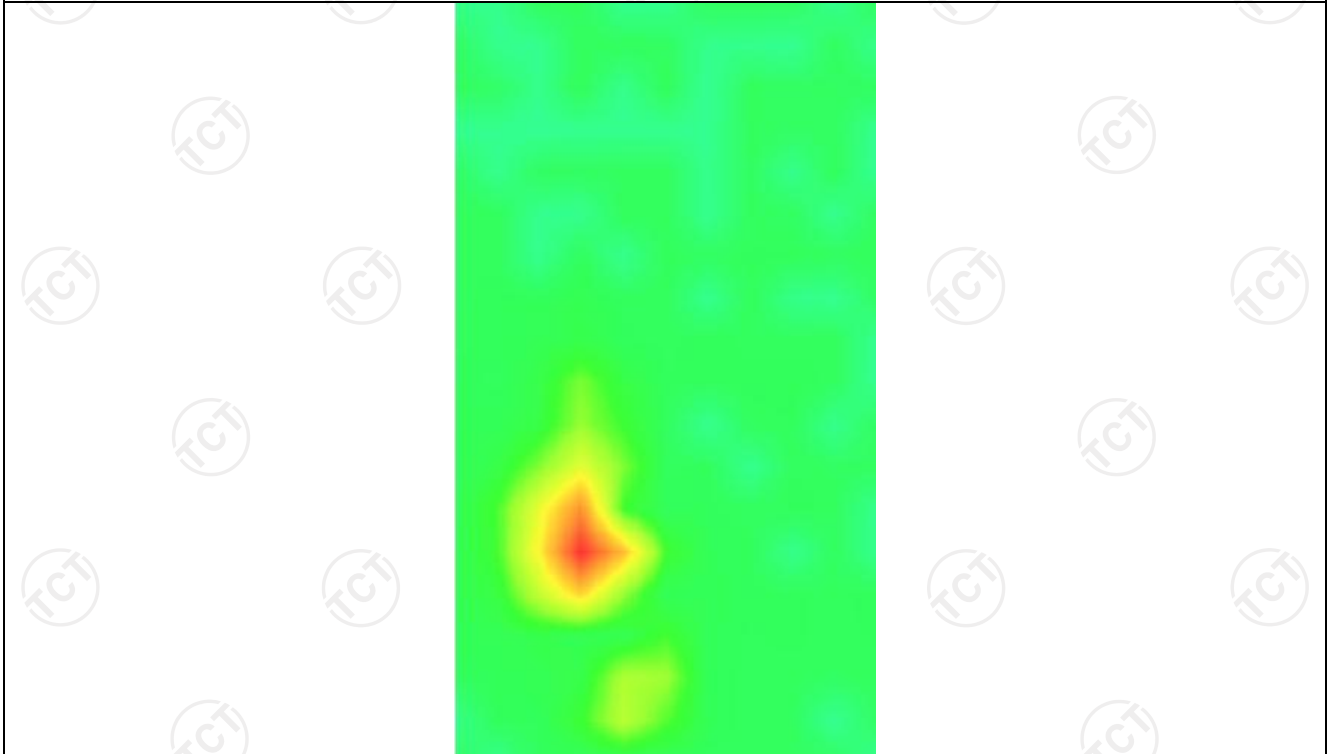

WLAN 5.8G

**MEASUREMENT 1**

SAR (Channel 165):

Date: 12/17/2021

<b>Frequency (MHz)</b>	5825.000000
<b>Relative permittivity (real part)</b>	47.813887
<b>Relative permittivity (imaginary part)</b>	14.935214
<b>Conductivity (S/m)</b>	6.124821
<b>Variation (%)</b>	-1.650000
<b>Crest Factor</b>	1.0
<b>Probe Conversion factor</b>	2.13
<b>E-Field Probe:</b>	SSE2 (SN 36/20 EPGO346)
<b>Area Scan</b>	<u>dx=8mm dy=8mm, h= 5.00 mm</u>
<b>ZoomScan</b>	<u>5x5x7,dx=8mm dy=8mm</u> <u>dz=5mm,Complete/ndx=8mm dy=8mm, h=</u> <u>5.00 mm</u>
<b>Phantom</b>	<u>Validation plane</u>
<b>Device Position</b>	<u>Body back(10mm)</u>
<b>Band</b>	<u>IEEE 802.11n HT20 ISM</u>

**SURFACE SAR**

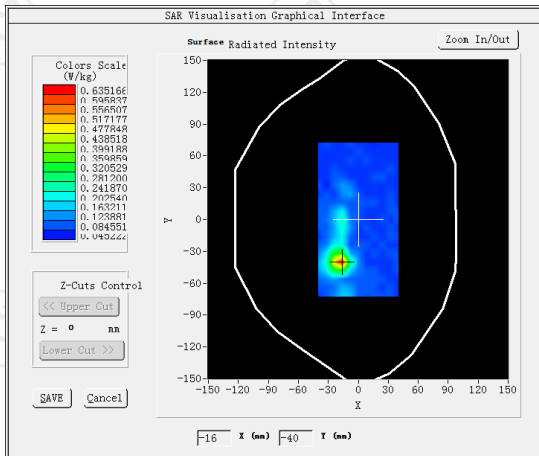

**VOLUME SAR**

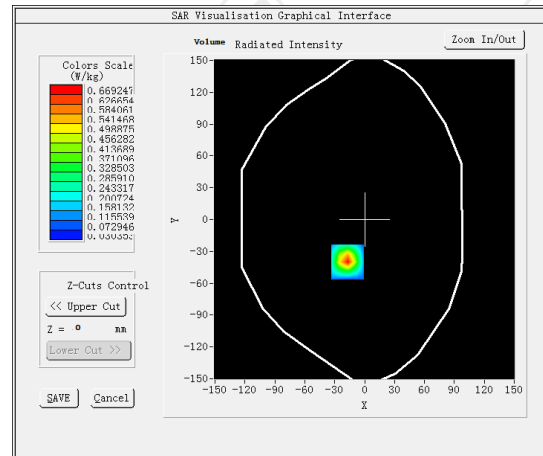

**Maximum location: X=-17.00, Y=-40.00 SAR Peak: 1.18 W/kg**

**SAR 10g (W/Kg)**

0.169772

**SAR 1g (W/Kg)**

0.342557

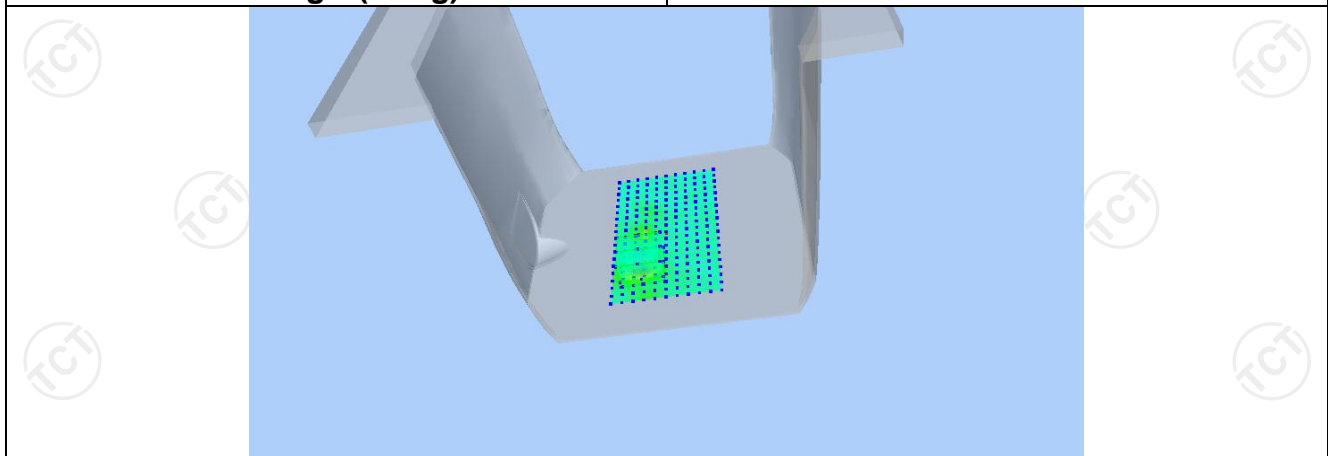



Z (mm)	0.00	2.00	7.00	12.00	17.00
SAR (W/Kg)	1.1106	0.6692	0.1416	0.0304	0.0315

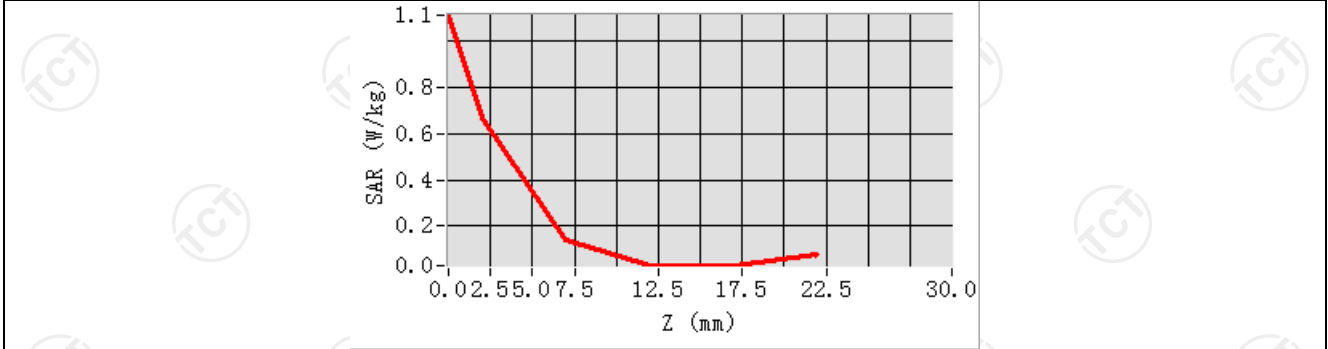

**Hot spot position**

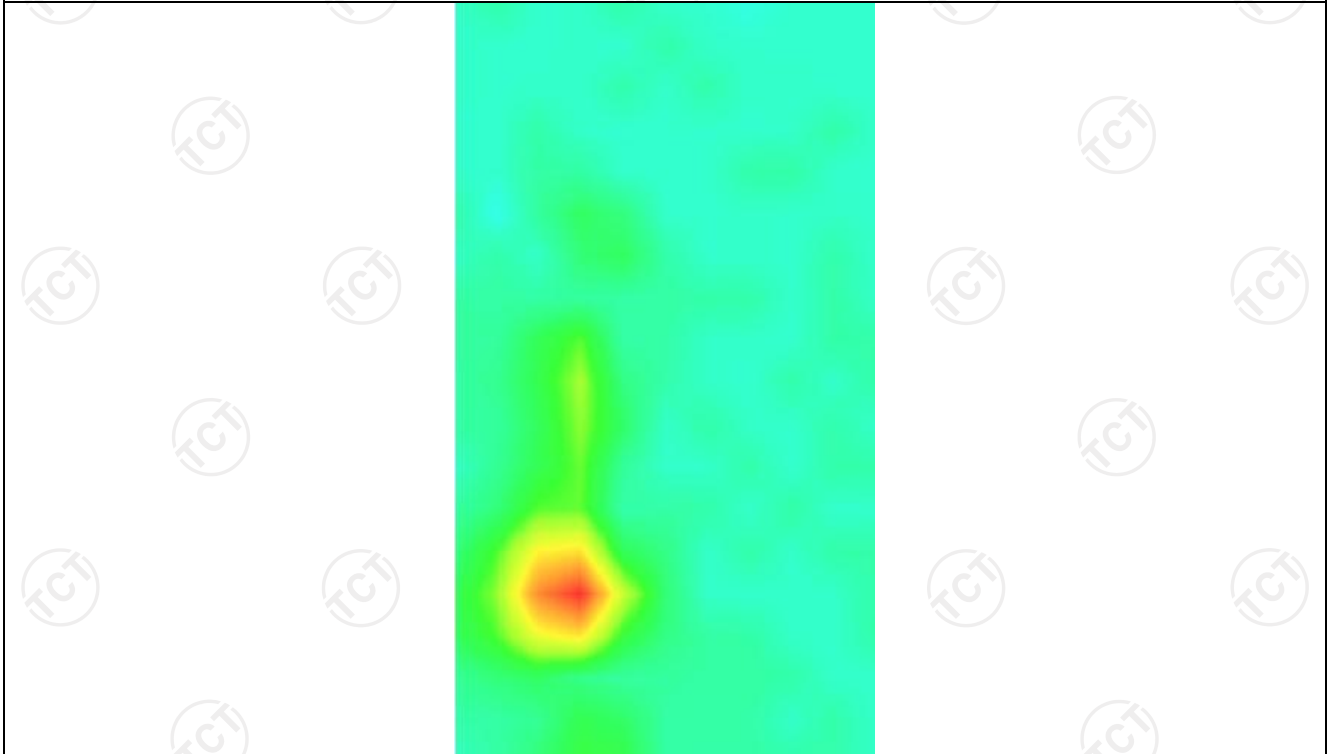

**MEASUREMENT 2**

SAR (Channel 165):

Date: 12/17/2021

Frequency (MHz)	5825.000000
Relative permittivity (real part)	47.813887
Relative permittivity (imaginary part)	14.935214
Conductivity (S/m)	6.124821
Variation (%)	-2.280000
Crest Factor	1.0
Probe Conversion factor	2.13
E-Field Probe:	SSE2 (SN 36/20 EPG0346)
Area Scan	<u>dx=8mm dy=8mm, h= 5.00 mm</u>
ZoomScan	<u>5x5x7,dx=8mm dy=8mm</u> <u>dz=5mm,Complete/ndx=8mm dy=8mm, h=</u> <u>5.00 mm</u>
Phantom	<u>Validation plane</u>
Device Position	<u>Body back(10mm)</u>
Band	<u>IEEE 802.11n HT20 ISM(hotspot)</u>

**SURFACE SAR**

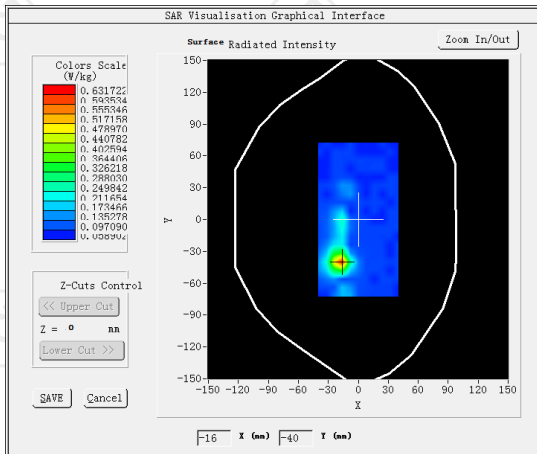

**VOLUME SAR**

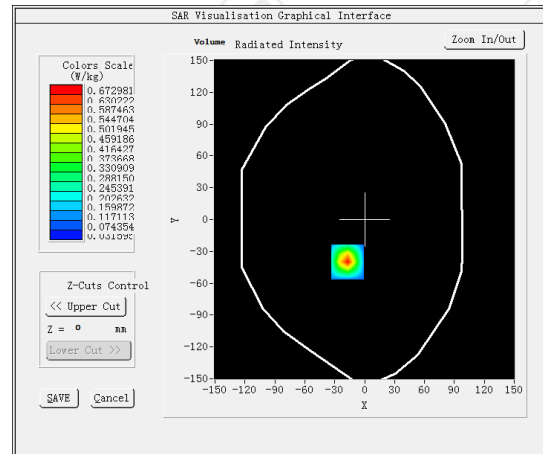

**Maximum location: X=-17.00, Y=-40.00 SAR Peak: 1.17 W/kg**

**SAR 10g (W/Kg)**

0.169650

**SAR 1g (W/Kg)**

0.364496

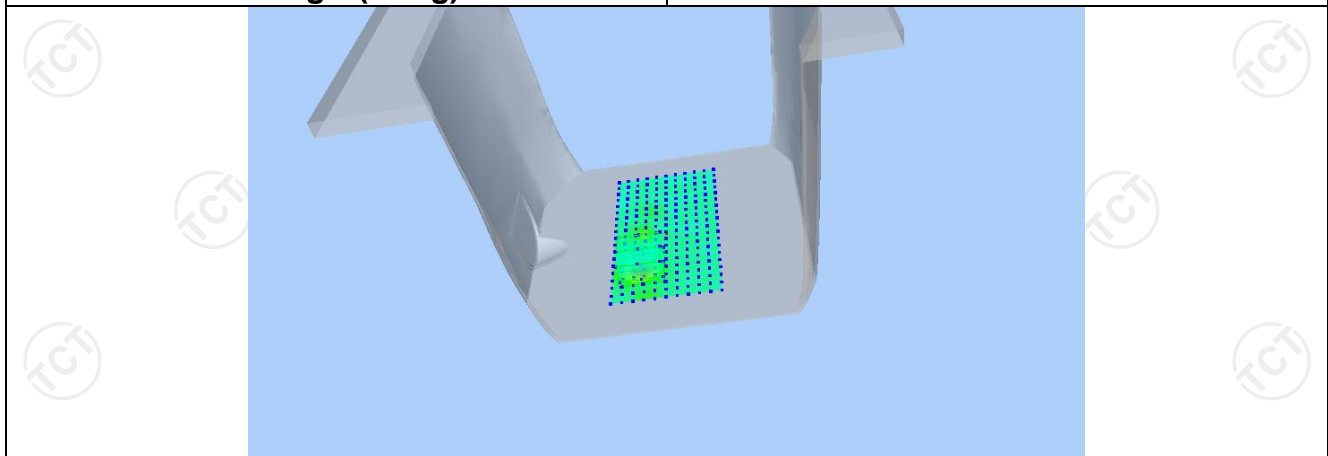

<b>Z (mm)</b>	<b>0.00</b>	<b>2.00</b>	<b>7.00</b>	<b>12.00</b>	<b>17.00</b>
<b>SAR (W/Kg)</b>	<b>1.1147</b>	<b>0.6730</b>	<b>0.1438</b>	<b>0.0316</b>	<b>0.0330</b>

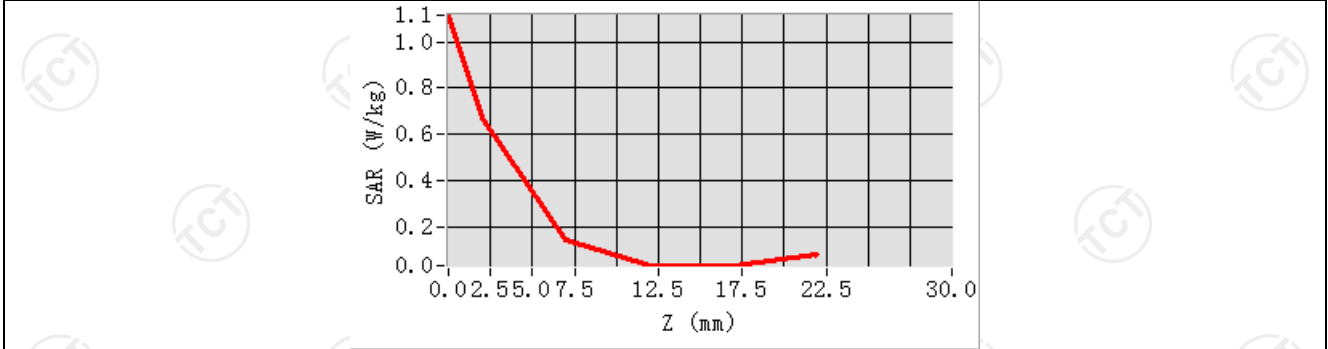

**Hot spot position**

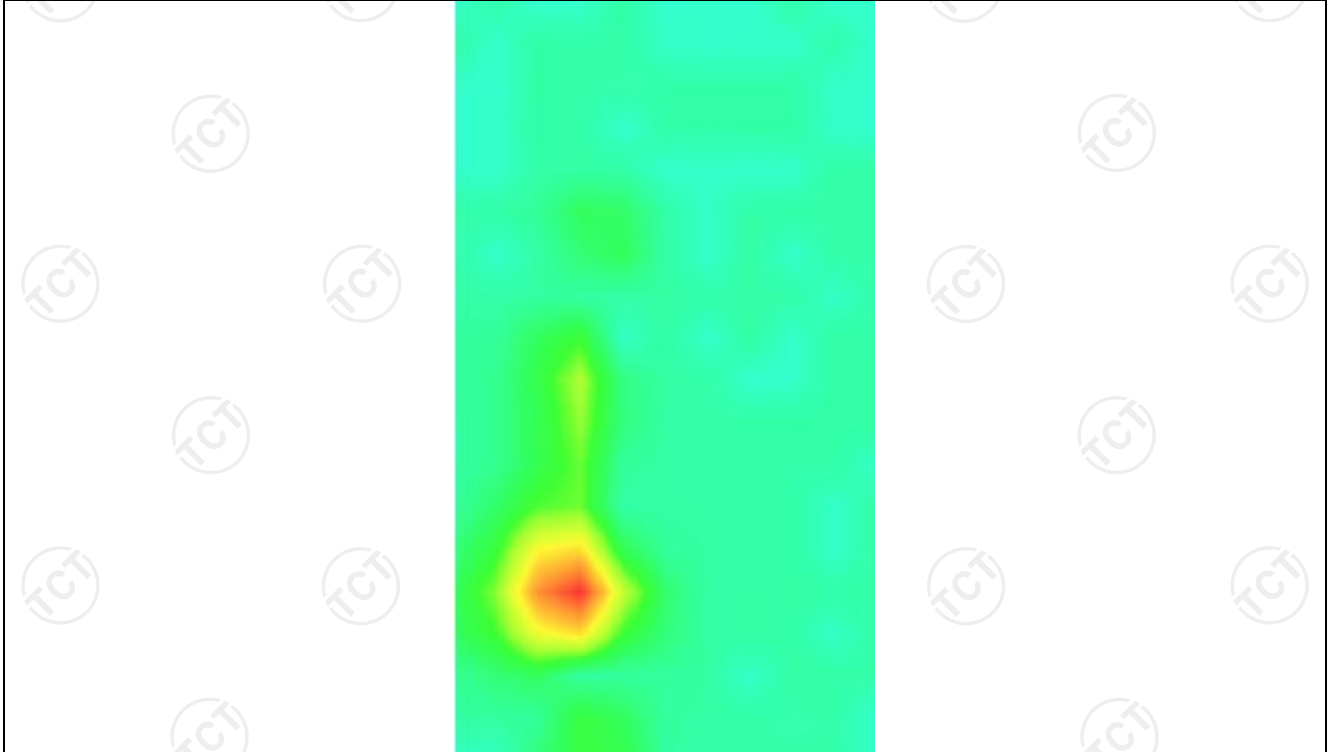

### Appendix A: EUT Photos



### Liquid depth



The Body Liquid of 835MHz (15.4cm)



The Body Liquid of 1800MHz (15.2 cm)



The Body Liquid of 1900MHz (16.4 cm)



The Body Liquid of 2450MHz (15.3cm)



The Body Liquid of 5000-6000MHz (16.5cm)

**Appendix B: Test Setup Photos**

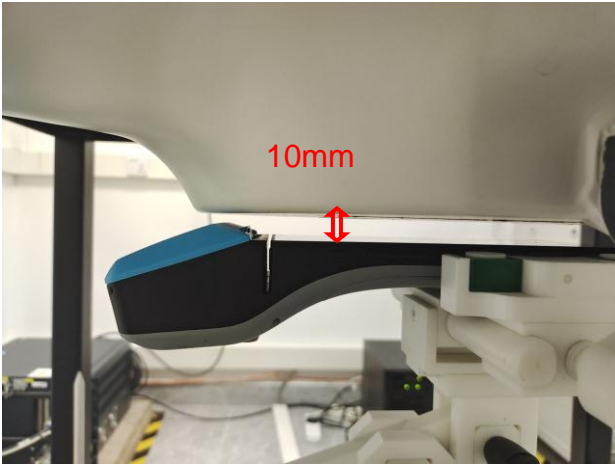

Body worn – Front (10mm)

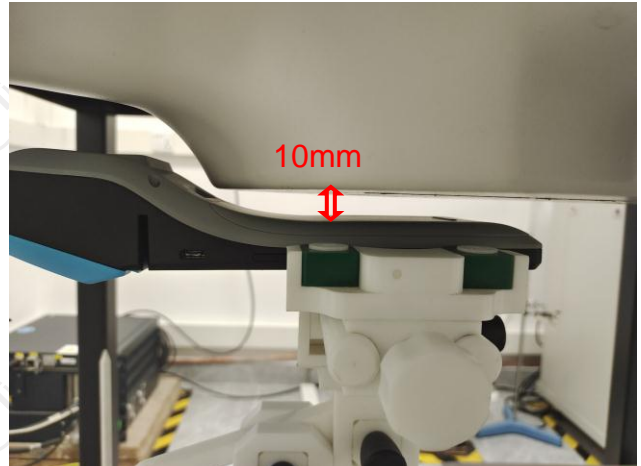

Body worn – Back (10mm)

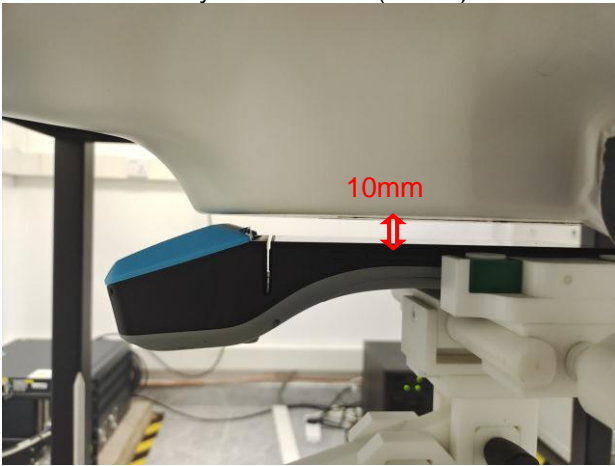

Hotspot Front (10mm)

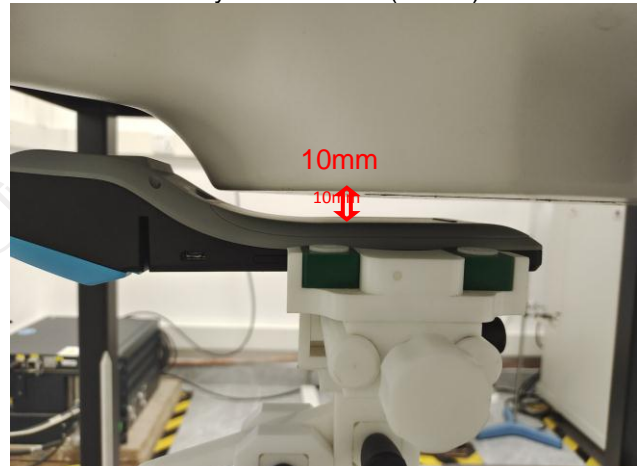

Hotspot Back (10mm)

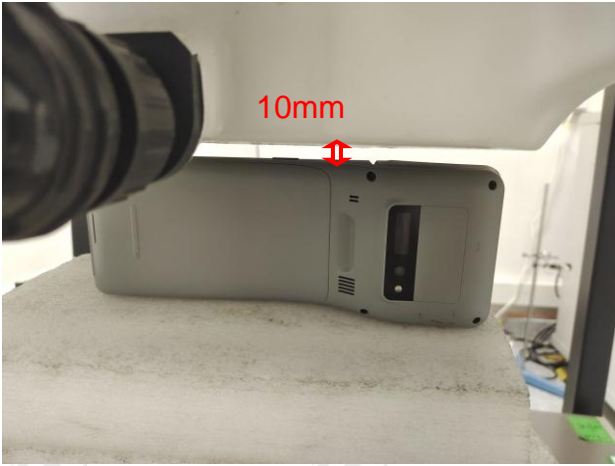

Hotspot Right (10mm)

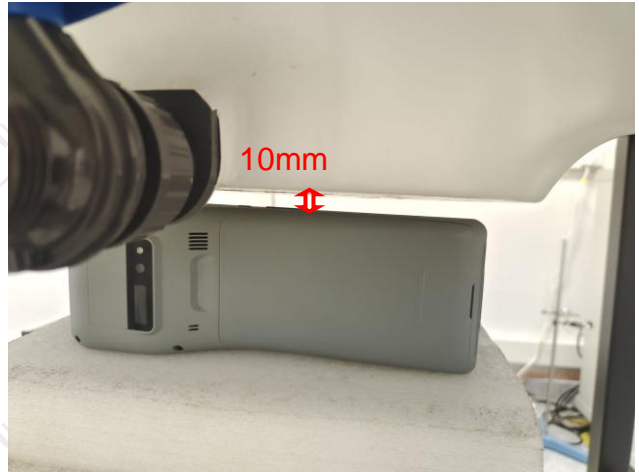

Hotspot Left (10mm)

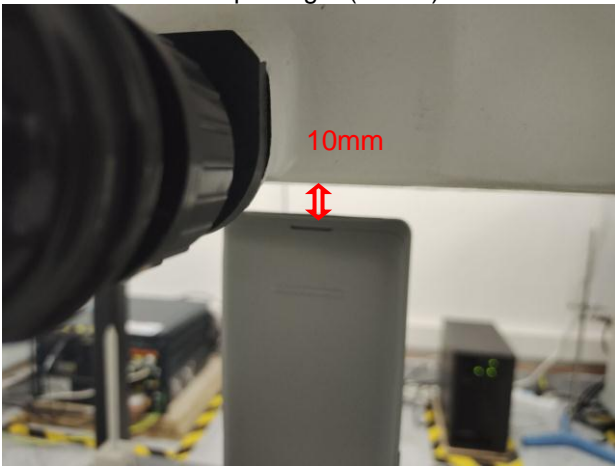

Hotspot Bottom (1mm)

## Appendix C: Probe Calibration Certificate

COMOSAR E-FIELD Probe



### COMOSAR E-Field Probe Calibration Report

Ref : ACR.297.1.20.MVGB.A

**SHENZHEN TONGCE TESTING LAB.**  
TCT TESTING INDUSTRIAL PARK, FUQIAO 5TH  
INDUSTRIAL ZONE, FUHAI STREET,  
BAOAN DISTRICT, SHENZHEN, GUANGDONG ,  
518103, PEOPLES REPUBLIC OF CHINA  
**MVG COMOSAR DOSIMETRIC E-FIELD PROBE**  
SERIAL NO.: SN 36/20 EPGO346

Calibrated at MVG  
Z.I. de la pointe du diable  
Technopôle Brest Iroise – 295 avenue Alexis de Rochon  
29280 PLOUZANE - FRANCE

Calibration date: 10/08/2021



Accreditations #2-6789 and #2-6814  
Scope available on [www.cofrac.fr](http://www.cofrac.fr)

#### Summary:

This document presents the method and results from an accredited COMOSAR E-Field Probe calibration performed at MVG, using the CALIPROBE test bench, for use with a MVG COMOSAR system only. The test results covered by accreditation are traceable to the International System of Units (SI).





COMOSAR E-FIELD PROBE CALIBRATION REPORT

Ref: ACR.297.1.20.MVGB.A

	<i>Name</i>	<i>Function</i>	<i>Date</i>	<i>Signature</i>
<i>Prepared by :</i>	Jérôme LUC	Technical Manager	10/08/2021	<i>JS</i>
<i>Checked by :</i>	Jérôme LUC	Technical Manager	10/08/2021	<i>JS</i>
<i>Approved by :</i>	Yann Toutain	Laboratory Director	10/11/2021	<i>Yann Toutain</i>

	<i>Customer Name</i>
<i>Distribution :</i>	SHENHEN TONGCE TESTING LAB.

<i>Issue</i>	<i>Name</i>	<i>Date</i>	<i>Modifications</i>
A	Jérôme LUC	10/08/2021	Initial release



**TABLE OF CONTENTS**

1	Device Under Test .....	4
2	Product Description .....	4
2.1	General Information .....	4
3	Measurement Method .....	4
3.1	Linearity .....	4
3.2	Sensitivity .....	5
3.3	Lower Detection Limit .....	5
3.4	Isotropy .....	5
3.1	Boundary Effect .....	5
4	Measurement Uncertainty .....	6
5	Calibration Measurement Results .....	6
5.1	Sensitivity in air .....	6
5.2	Linearity .....	7
5.3	Sensitivity in liquid .....	8
5.4	Isotropy .....	9
6	List of Equipment .....	10



**1 DEVICE UNDER TEST**

Device Under Test	
Device Type	COMOSAR DOSIMETRIC E FIELD PROBE
Manufacturer	MVG
Model	SSE2
Serial Number	SN 36/20 EPGO346
Product Condition (new / used)	New
Frequency Range of Probe	0.15 GHz-6GHz
Resistance of Three Dipoles at Connector	Dipole 1: R1=0.217 MΩ Dipole 2: R2=0.245 MΩ Dipole 3: R3=0.219 MΩ

**2 PRODUCT DESCRIPTION**

**2.1 GENERAL INFORMATION**

MVG's COMOSAR E field Probes are built in accordance to the IEEE 1528, FCC KDB865664 D01, CENELEC EN62209 and CEI/IEC 62209 standards.



Figure 1 – MVG COMOSAR Dosimetric E field Dipole

Probe Length	330 mm
Length of Individual Dipoles	2 mm
Maximum external diameter	8 mm
Probe Tip External Diameter	2.5 mm
Distance between dipoles / probe extremity	1 mm

**3 MEASUREMENT METHOD**

The IEEE 1528, FCC KDB865664 D01, CENELEC EN62209 and CEI/IEC 62209 standards provide recommended practices for the probe calibrations, including the performance characteristics of interest and methods by which to assess their affect. All calibrations / measurements performed meet the fore mentioned standards.

**3.1 LINEARITY**

The evaluation of the linearity was done in free space using the waveguide, performing a power sweep to cover the SAR range 0.01W/kg to 100W/kg.



### 3.2 SENSITIVITY

The sensitivity factors of the three dipoles were determined using a two step calibration method (air and tissue simulating liquid) using waveguides as outlined in the standards.

### 3.3 LOWER DETECTION LIMIT

The lower detection limit was assessed using the same measurement set up as used for the linearity measurement. The required lower detection limit is 10 mW/kg.

### 3.4 ISOTROPY

The axial isotropy was evaluated by exposing the probe to a reference wave from a standard dipole with the dipole mounted under the flat phantom in the test configuration suggested for system validations and checks. The probe was rotated along its main axis from 0 to 360 degrees in 15-degree steps. The hemispherical isotropy is determined by inserting the probe in a thin plastic box filled with tissue-equivalent liquid, with the plastic box illuminated with the fields from a half wave dipole. The dipole is rotated about its axis (0°–180°) in 15° increments. At each step the probe is rotated about its axis (0°–360°).

### 3.1 BOUNDARY EFFECT

The boundary effect is defined as the deviation between the SAR measured data and the expected exponential decay in the liquid when the probe is oriented normal to the interface. To evaluate this effect, the liquid filled flat phantom is exposed to fields from either a reference dipole or waveguide. With the probe normal to the phantom surface, the peak spatial average SAR is measured and compared to the analytical value at the surface.

The boundary effect uncertainty can be estimated according to the following uncertainty approximation formula based on linear and exponential extrapolations between the surface and  $d_{be} + d_{step}$  along lines that are approximately normal to the surface:

$$SAR_{uncertainty} [\%] = \Delta SAR_{be} \frac{(d_{be} + d_{step})^2}{2d_{step}} \frac{(e^{-d_{be}/\delta})^2}{\delta/2} \quad \text{for } (d_{be} + d_{step}) < 10 \text{ mm}$$

where

- $SAR_{uncertainty}$  is the uncertainty in percent of the probe boundary effect
- $d_{be}$  is the distance between the surface and the closest *zoom-scan* measurement point, in millimetre
- $\Delta_{step}$  is the separation distance between the first and second measurement points that are closest to the phantom surface, in millimetre, assuming the boundary effect at the second location is negligible
- $\delta$  is the minimum penetration depth in millimetres of the head tissue-equivalent liquids defined in this standard, i.e.,  $\delta \approx 14$  mm at 3 GHz;
- $\Delta SAR_{be}$  in percent of SAR is the deviation between the measured SAR value, at the distance  $d_{be}$  from the boundary, and the analytical SAR value.



The measured worst case boundary effect SAR uncertainty [%] for scanning distances larger than 4mm is 1.0% Limit (2%).

#### 4 MEASUREMENT UNCERTAINTY

The guidelines outlined in the IEEE 1528, OET 65 Bulletin C, CENELEC EN50361 and CEI/IEC 62209 standards were followed to generate the measurement uncertainty associated with an E-field probe calibration using the waveguide technique. All uncertainties listed below represent an expanded uncertainty expressed at approximately the 95% confidence level using a coverage factor of k=2, traceable to the Internationally Accepted Guides to Measurement Uncertainty.

Uncertainty analysis of the probe calibration in waveguide					
ERROR SOURCES	Uncertainty value (%)	Probability Distribution	Divisor	ci	Standard Uncertainty (%)
Expanded uncertainty 95 % confidence level k = 2					14 %

#### 5 CALIBRATION MEASUREMENT RESULTS

Calibration Parameters	
Liquid Temperature	20 +/- 1 °C
Lab Temperature	20 +/- 1 °C
Lab Humidity	30-80 %

##### 5.1 SENSITIVITY IN AIR

Normx dipole 1 (µV/(V/m) <sup>2</sup> )	Normy dipole 2 (µV/(V/m) <sup>2</sup> )	Normz dipole 3 (µV/(V/m) <sup>2</sup> )
0.81	0.71	0.80

DCP dipole 1 (mV)	DCP dipole 2 (mV)	DCP dipole 3 (mV)
115	112	112

Calibration curves  $e_i=f(V)$  (i=1,2,3) allow to obtain E-field value using the formula:

$$E = \sqrt{E_1^2 + E_2^2 + E_3^2}$$



COMOSAR E-FIELD PROBE CALIBRATION REPORT

Ref: ACR.297.1.20.MVGB.A

Calibration curves

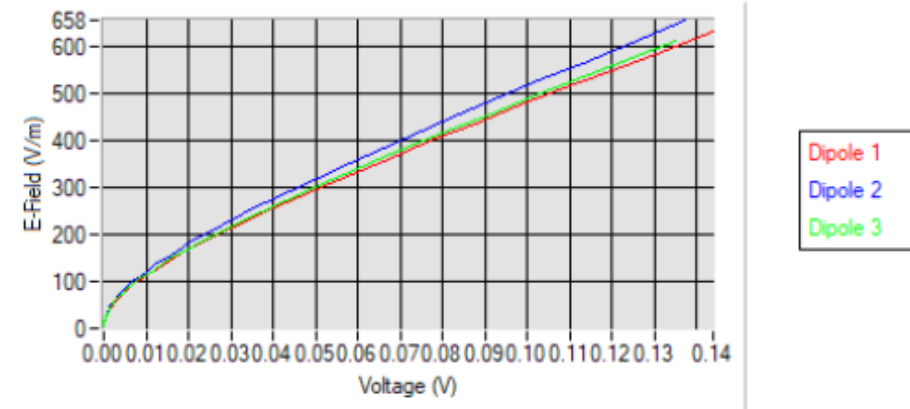

5.2 LINEARITY

Linearity

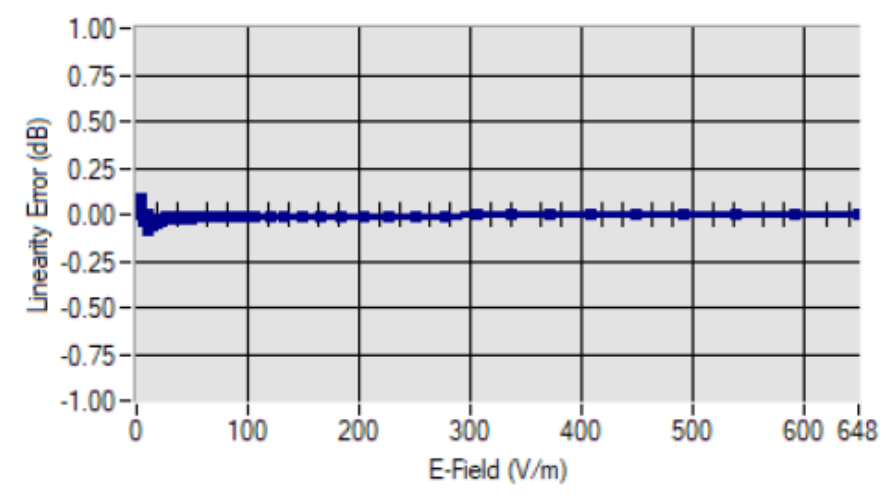

Linearity: +/-1.97% (+/-0.09dB)



COMOSAR E-FIELD PROBE CALIBRATION REPORT

Ref: ACR.297.1.20.MVGB.A

5.3 SENSITIVITY IN LIQUID

Liquid	Frequency (MHz +/- 100MHz)	ConvF	Epsilon (S/m)	Permittivity
HL750	750	1.71	0.93	40.76
BL750	750	1.78	0.98	56.70
HL900	900	1.91	0.93	41.94
BL900	900	1.96	0.98	54.62
HL1800	1800	2.08	1.29	40.86
BL1800	1800	2.16	1.47	52.27
HL2000	2000	2.03	1.42	38.37
BL2000	2000	2.10	1.52	52.03
HL2450	2450	2.31	1.80	38.72
BL2450	2450	2.37	1.97	54.91
HL2600	2600	2.16	1.89	39.98
BL2600	2600	2.23	2.18	54.42
HL5200	5200	2.01	4.45	36.68
BL5200	5200	2.08	5.46	49.02
HL5800	5800	2.06	5.08	34.81
BL5800	5800	2.13	6.12	47.81

LOWER DETECTION LIMIT: 8mW/kg



5.4 ISOTROPY

HL1800 MHz

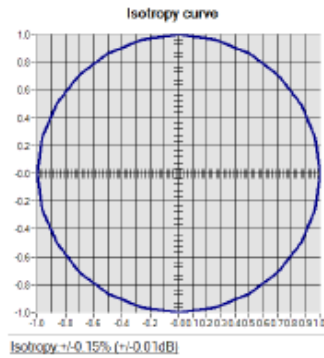





6 LIST OF EQUIPMENT

Equipment Summary Sheet				
Equipment Description	Manufacturer / Model	Identification No.	Current Calibration Date	Next Calibration Date
Flat Phantom	MVG	SN-20/09-SAM71	Validated. No cal required.	Validated. No cal required.
COMOSAR Test Bench	Version 3	NA	Validated. No cal required.	Validated. No cal required.
Network Analyzer	Rohde & Schwarz ZVM	100203	05/2019	05/2022
Network Analyzer – Calibration kit	Rohde & Schwarz ZV-Z235	101223	05/2019	05/2022
Multimeter	Keithley 2000	1160271	02/2020	02/2023
Signal Generator	Rohde & Schwarz SMB	106589	04/2019	04/2022
Amplifier	Aethercomm	SN 046	Characterized prior to test. No cal required.	Characterized prior to test. No cal required.
Power Meter	NI-USB 5680	170100013	05/2019	05/2022
Directional Coupler	Narda 4216-20	01386	Characterized prior to test. No cal required.	Characterized prior to test. No cal required.
Waveguide	Mega Industries	069Y7-158-13-712	Validated. No cal required.	Validated. No cal required.
Waveguide Transition	Mega Industries	069Y7-158-13-701	Validated. No cal required.	Validated. No cal required.
Waveguide Termination	Mega Industries	069Y7-158-13-701	Validated. No cal required.	Validated. No cal required.
Temperature / Humidity Sensor	Testo 184 H1	44220687	05/2020	05/2023



## Dielectric Probe Calibration Report

Ref : ACR.138.4.33.SATU.A

**SHENZHEN TONGCE TESTING LAB.**  
TCT TESTING INDUSTRIAL PARK, FUQIAO 5TH INDUSTRIAL  
ZONE, FUHAI STREET, BAOAN DISTRICT, SHENZHEN CHINA  
**MVG COMOSAR DOSIMETRIC E-FIELD PROBE**

**FREQUENCY: 0.3-6 GHZ**  
**SERIAL NO.: SN 19/15 OCPG 71**

**Calibrated at MVG US**  
2105 Barrett Park Dr. - Kennesaw, GA 30144



**Calibration Date: 06/05/2021**

*Summary:*

This document presents the method and results from an accredited Dielectric Probe calibration performed in MVG USA using the LIMESAR test bench. All calibration results are traceable to national metrology institutions.



SAR DIELECTRIC PROBE CALIBRATION REPORT

Ref: ACR.138.4.33.SATUA

	Name	Function	Date	Signature
Prepared by :	Jérôme LUC	Product Manager	06/05/2021	<i>JS</i>
Checked by :	Jérôme LUC	Product Manager	06/05/2021	<i>JS</i>
Approved by :	Kim RUTKOWSKI	Quality Manager	06/05/2021	<i>Kim Rutkowski</i>

	Customer Name
Distribution :	SHENZHEN TONGCE TESTING LAB

Issue	Date	Modifications
A	06/05/2021	Initial release



**TABLE OF CONTENTS**

1	Introduction.....	4
2	Device Under Test .....	4
3	Product Description .....	4
3.1	General Information .....	4
4	Measurement Method .....	5
4.1	Liquid Permittivity Measurements .....	5
5	Measurement Uncertainty .....	5
5.1	Dielectric Permittivity Measurement .....	5
6	Calibration Measurement Results .....	6
6.1	Liquid Permittivity Measurement .....	6
7	List of Equipment .....	7

Page: 3/7

*This document shall not be reproduced, except in full or in part, without the written approval of MVG.  
The information contained herein is to be used only for the purpose for which it is submitted and is not to be released in whole or part without written approval of MVG.*



**1 INTRODUCTION**

This document contains a summary of the suggested methods and requirements set forth by the IEEE 1528 and CEI/IEC 62209 standards for liquid permittivity measurements and the measurements that were performed to verify that the product complies with the fore mentioned standards.

**2 DEVICE UNDER TEST**

Device Under Test	
Device Type	LIMESAR DIELECTRIC PROBE
Manufacturer	MVG
Model	SCLMP
Serial Number	SN 19/15 OCPG 71
Product Condition (new / used)	Used

A yearly calibration interval is recommended.

**3 PRODUCT DESCRIPTION**

**3.1 GENERAL INFORMATION**

MVG's Dielectric Probes are built in accordance to the IEEE 1528 and CEI/IEC 62209 standards. The product is designed for use with the LIMESAR test bench only.



**Figure 1 – MVG LIMESAR Dielectric Probe**



**4 MEASUREMENT METHOD**

The IEEE 1528, OET 65 Bulletin C and CEI/IEC 62209-1 & 2 standards outline techniques for dielectric property measurements. The LIMESAR test bench employs one of the methods outlined in the standards, using a contact probe or open-ended coaxial transmission-line probe and vector network analyzer. The standards recommend the measurement of two reference materials that have well established and stable dielectric properties to validate the system, one for the calibration and one for checking the calibration. The LIMESAR test bench uses De-ionized water as the reference for the calibration and either DMS or Methanol as the reference for checking the calibration. The following measurements were performed to verify that the product complies with the fore mentioned standards.

**4.1 LIQUID PERMITTIVITY MEASUREMENTS**

The permittivity of a liquid with well established dielectric properties was measured and the measurement results compared to the values provided in the fore mentioned standards.

**5 MEASUREMENT UNCERTAINTY**

All uncertainties listed below represent an expanded uncertainty expressed at approximately the 95% confidence level using a coverage factor of k=2, traceable to the Internationally Accepted Guides to Measurement Uncertainty.

**5.1 DIELECTRIC PERMITTIVITY MEASUREMENT**

The following uncertainties apply to the Dielectric Permittivity measurement:

Uncertainty analysis of Permittivity Measurement					
ERROR SOURCES	Uncertainty value (+/-%)	Probability Distribution	Divisor	ci	Standard Uncertainty (+/-%)
Repeatability (n repeats, mid-band)	4.00%	N	1	1	4.000%
Deviation from reference liquid	5.00%	R	√3	1	2.887%
Network analyser-drift, linearity	2.00%	R	√3	1	1.155%
Test-port cable variations	0.00%	U	√2	1	0.000%
<b>Combined standard uncertainty</b>					5.066%
<b>Expanded uncertainty (confidence level of 95%, k = 2)</b>					10.0%

Uncertainty analysis of Conductivity Measurement					
ERROR SOURCES	Uncertainty value (+/-%)	Probability Distribution	Divisor	ci	Standard Uncertainty (+/-%)
Repeatability (n repeats, mid-band)	3.50%	N	1	1	3.500%
Deviation from reference liquid	3.00%	R	√3	1	1.732%
Network analyser-drift, linearity	2.00%	R	√3	1	1.155%
Test-port cable variations	0.00%	U	√2	1	0.000%
<b>Combined standard uncertainty</b>					4.072%
<b>Expanded uncertainty (confidence level of 95%, k = 2)</b>					8.1%



SAR DIELECTRIC PROBE CALIBRATION REPORT

Ref. ACR.138.4.33..SATU.A

6 CALIBRATION MEASUREMENT RESULTS

Measurement Condition

Software	LIMESAR
Liquid Temperature	21°C
Lab Temperature	21°C
Lab Humidity	44%

6.1 LIQUID PERMITTIVITY MEASUREMENT

A liquid of known characteristics (methanol at 20°C) is measured with the probe and the results (complex permittivity  $\epsilon' + j\epsilon''$ ) are compared with the well-known theoretical values for this liquid.

