

FCC Radio Test Report

FCC ID: 2APBP-CS50

Original Grant

Report No. : TB-FCC185240
Applicant : Ciontek Technology Corp.
Equipment Under Test (EUT)
EUT Name : Smart POS Payment Terminal
Model No. : CS50
Series Model No. : CS50PRO, CS50LITE, CS50S, CS50V, CS50MINI, CS50A, CS50C, CS51, CS52
Brand Name : Ciontek
Sample ID : 20211111-01_01-01#& 20211111-01_01-02#
Receipt Date : 2021-11-17
Test Date : 2021-11-17 to 2022-01-11
Issue Date : 2021-01-11
Standards : 47 CFR Part 2, 22(H), 24(E), 27
Test Method : ANSI C63.26 2015
Conclusions : **PASS**

In the configuration tested, the EUT complied with the standards specified above,

The EUT technically complies with the FCC requirements

Test/Witness Engineer :

Camille Li

Camille Li

Engineer Supervisor :

Ivan Su

Ivan Su

Engineer Manager :

Ray Lai

Ray Lai



This report details the results of the testing carried out on one sample. The results contained in this test report do not relate to other samples of the same product. The manufacturer should ensure that all products in series production are in conformity with the product sample detailed in the report.

Contents

CONTENTS	2
1. GENERAL INFORMATION ABOUT EUT	5
1.1 Client Information.....	5
1.2 General Description of EUT (Equipment Under Test)	5
1.3 Block Diagram Showing the Configuration of System Tested.....	10
1.4 Description of Support Units	10
1.5 Description of Test Mode.....	11
1.6 Measurement Uncertainty	12
1.7 Test Facility.....	13
2. TEST SUMMARY	14
3. TEST EQUIPMENT	15
4. CONDUCTED RF OUTPUT POWER	16
4.1 Test Standard and Limit.....	16
4.2 Test Setup.....	16
4.3 Test Procedure.....	16
4.4 EUT Operating Condition	16
4.5 Deviation From Test Standard.....	16
4.6 Test Data.....	16
5. PEAK-AVERAGE RATIO	17
5.1 Test Standard and Limit.....	17
5.2 Test Setup.....	17
5.3 Test Procedure.....	17
5.4 EUT Operating Condition	17
5.5 Deviation From Test Standard.....	17
5.6 Test Data.....	17
6. OCCUPIED BANDWIDTH	18
6.1 Test Standard and Limit.....	18
6.2 Test Setup.....	18
6.3 Test Procedure.....	18
6.4 EUT Operating Condition	19
6.5 Deviation From Test Standard.....	19
6.6 Test Data.....	19
7. OUT OF BAND EMISSION AT ANTENNA TERMINALS	20
7.1 Test Standard and Limit.....	20
7.2 Test Setup.....	20
7.3 Test Procedure.....	21
7.4 EUT Operating Condition	21
7.5 Deviation From Test Standard.....	21
7.6 Test Data.....	21
8. BAND EDGE TEST	22
8.1 Test Standard and Limit.....	22

8.2 Test Setup.....	22
8.3 Test Procedure.....	22
8.4 EUT Operating Condition	23
8.5 Deviation From Test Standard.....	23
8.6 Test Data.....	23
9. RADIATED OUTPUT POWER	24
9.1 Test Standard and Limit.....	24
9.2 Test Setup.....	24
9.3 Test Procedure.....	25
9.4 EUT Operating Condition	25
9.5 Deviation From Test Standard.....	25
9.6 Test Data.....	25
10. RADIATED OUT BAND OF EMISSIONS.....	26
10.1 Test Standard and Limit	26
10.2 Test Setup.....	26
10.3 Test Procedure.....	26
10.4 EUT Operating Condition	27
10.5 Deviation From Test Standard.....	27
10.6 Test Data.....	27
11. FREQUENCY STABILITY.....	28
11.1 Test Standard and Limit	28
11.2 Test Setup.....	28
11.3 Test Procedure.....	29
11.4 EUT Operating Condition	29
11.5 Deviation From Test Standard.....	29
11.6 Test Data.....	29
ATTACHMENT F--RADIATED OUTPUT POWER	30
ATTACHMENT G--RADIATED OUT BAND OF EMISSIONS.....	41

1. General Information about EUT

1.1 Client Information

Applicant	:	Ciontek Technology Corp.
Address	:	B501, Chanxueyan Building Wuhan University, No.6 Of Yuexing 2nd Road, Yuehai Street, Nanshan District, Shenzhen, China
Manufacturer	:	Ciontek Technology Corp.
Address	:	B501, Chanxueyan Building Wuhan University, No.6 Of Yuexing 2nd Road, Yuehai Street, Nanshan District, Shenzhen, China

1.2 General Description of EUT (Equipment Under Test)

EUT Name	:	Smart POS Payment Terminal
Models No.	:	CS50, CS50PRO, CS50LITE, CS50S, CS50V, CS50MINI, CS50A, CS50C, CS51, CS52
Model Difference	:	All PCB boards and circuit diagrams are the same, the only difference is the color appearance.
Product Description	:	<p>Frequency Bands: LTE Band 2:TX: 1850MHz-1910MHz, RX: 1930MHz-1990MHz LTE Band 4:TX: 1710MHz-1755MHz, RX: 2110MHz-2155MHz LTE Band 5:TX: 824MHz-849MHz, RX: 869MHz-894MHz LTE Band 12: TX: 699MHz -716MHz, RX: 729MHz-746MHz LTE Band 17: TX: 704MHz -716MHz, RX: 734MHz-746MHz</p>
	Antenna Gain:	0.8dBi PIFA Antenna
	Modulation Type:	QPSK, 16QAM
	Bandwidth:	LTE Band 2 :1.4MHz/3MHz/5MHz/10MHz/15MHz/20MHz LTE Band 4 :1.4MHz/3MHz/5MHz/10MHz/15MHz/20MHz LTE Band 5 :1.4MHz/3MHz/5MHz/10MHz LTE Band 12 :1.4MHz/3MHz/5MHz/10MHz LTE Band 17 :5MHz/10MHz
Power Rating	:	For Adapter: Input: 100-240V~ 50/60Hz Output:5V ⁼⁼ , 2A
Battery	:	DC 7.6V by 2600mAh rechargeable Li-ion Battery
Software Version	:	a52_v0.09_20211103g
Hardware Version	:	CS50HWV2.0
Remark	:	The antenna gain and adapter provided by the applicant, the verified for the RF conduction test provided by TOBY test lab.

Note:

- (1) For a more detailed features description, please refer to the manufacturer's specifications or the User's Manual.
- (2) Channel List

LTE Band 2(1.4MHz)		LTE Band 2(3MHz)	
Channel	Frequency (MHz)	Channel	Frequency (MHz)
18607	1850.70	18615	1851.50
18608	1850.80	18616	1851.60
.....
18899	1879.90	18899	1879.90
18900	1880.00	18900	1880.00
18901	1880.10	18901	1880.10
.....
19192	1909.20	19184	1905.40
19193	1909.30	19185	1908.50
LTE Band 2(5MHz)		LTE Band 2(10MHz)	
Channel	Frequency (MHz)	Channel	Frequency (MHz)
18625	1852.50	18650	1855.00
18616	1853.60	18626	1854.90
.....
18899	1879.90	18899	1879.90
18900	1880.00	18900	1880.00
18901	1880.10	18901	1880.10
.....
19174	1908.40	19149	1907.90
19175	1907.50	19150	1905.00
LTE Band 2(15MHz)		LTE Band 2(20MHz)	
Channel	Frequency (MHz)	Channel	Frequency (MHz)
18675	1857.50	18700	1860.00
18676	1857.60	18701	1860.10
.....
18899	1879.90	18899	1879.90
18900	1880.00	18900	1880.00
18901	1880.10	18901	1880.10
.....
19124	1902.40	19099	1899.90
19125	1902.50	19100	1900.00

LTE Band 4(1.4MHz)		LTE Band 4(3MHz)	
Channel	Frequency (MHz)	Channel	Frequency (MHz)
19957	1710.70	19965	1711.50
19958	1710.80	19966	1711.60
.....
20174	1732.40	20174	1732.40
20175	1732.50	20175	1732.50
20176	1732.60	20176	1732.60
.....
20392	1754.20	20384	1753.40
20393	1754.30	20385	1753.50
LTE Band 4(5MHz)		LTE Band 4(10MHz)	
Channel	Frequency (MHz)	Channel	Frequency (MHz)
19975	1712.50	20000	1715.00
19976	1712.60	20001	1715.10
.....
20174	1732.40	20174	1732.40
20175	1732.50	20175	1732.50
20176	1732.60	20176	1732.60
.....
20374	1752.40	20349	1749.90
20375	1752.50	20350	1750.00
LTE Band 4(15MHz)		LTE Band 4(20MHz)	
Channel	Frequency (MHz)	Channel	Frequency (MHz)
20025	1717.50	20050	1720.00
20026	1717.60	20051	1720.10
.....
20174	1732.40	20174	1732.40
20175	1732.50	20175	1732.50
20176	1732.60	20176	1732.60
.....
20324	1747.40	20299	1744.90
20325	1747.50	20300	1745.00

LTE Band 5(1.4MHz)		LTE Band 5(3MHz)	
Channel	Frequency (MHz)	Channel	Frequency (MHz)
20407	824.70	20415	825.50
20408	824.80	20416	825.60
.....
20524	836.40	20524	836.40
20525	836.50	20525	836.50
20526	836.60	20526	836.60
.....
20643	848.20	20634	847.40
20643	848.30	20635	847.50
LTE Band 5(5MHz)		LTE Band 5(10MHz)	
Channel	Frequency (MHz)	Channel	Frequency (MHz)
20425	826.50	20450	829.00
20426	826.60	20451	829.10
.....
20524	836.40	20524	836.40
20525	836.50	20525	836.50
20526	836.60	20526	836.60
.....
20624	846.40	20599	843.90
20625	846.50	20600	844.00
LTE Band 12(1.4MHz)		LTE Band 12(3MHz)	
Channel	Frequency (MHz)	Channel	Frequency (MHz)
23017	699.70	23025	700.50
23018	699.80	23026	700.60
.....
23094	707.40	23094	707.40
23095	707.50	23095	707.50
23096	707.60	23096	707.60
.....
23172	715.20	23164	714.30
23173	715.30	23165	714.40

LTE Band 12(5MHz)		LTE Band 12(10MHz)	
Channel	Frequency (MHz)	Channel	Frequency (MHz)
23035	701.50	23060	704.00
23036	701.40	23061	703.90
.....
23094	707.40	23094	707.40
23095	707.50	23095	707.50
23096	707.60	23096	707.60
.....
23156	713.40	23129	710.90
23155	713.50	23130	711.00
LTE Band 17(5MHz)		LTE Band 17(10MHz)	
Channel	Frequency (MHz)	Channel	Frequency (MHz)
23755	706.50	23780	709.00
23756	706.60	23781	709.10
.....
23789	709.90	23789	709.90
23790	710.00	23790	710.00
23791	710.10	23791	710.10
.....
23524	713.40	23799	710.90
23825	713.50	23800	711.00

1.3 Block Diagram Showing the Configuration of System Tested

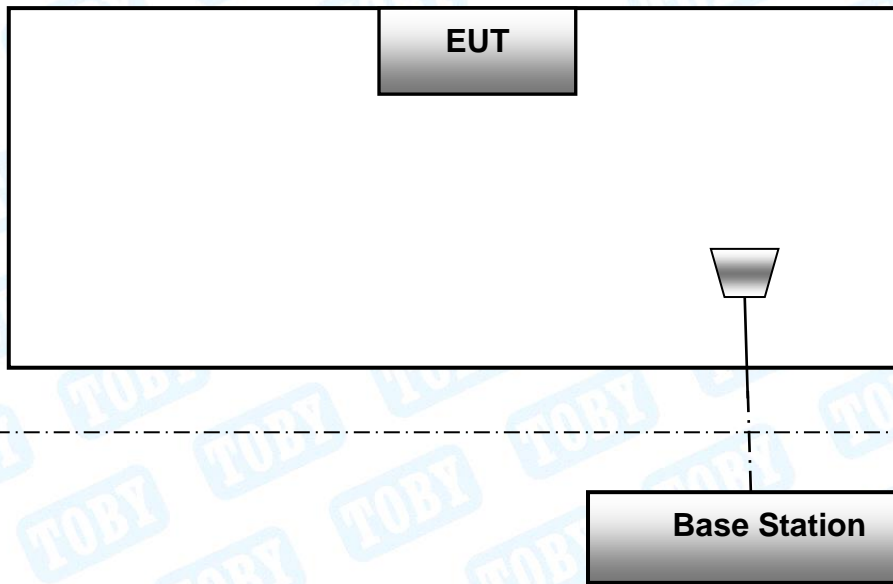

The above block diagram of setup is the normal mode. And more detail please refer to the test setup of each test item of bellow.

1.4 Description of Support Units

The EUT has been tested as an independent unit.

1.5 Description of Test Mode

Antenna port conducted and radiated test items listed below are performed according to KDB 971168 D01 v03r01 and ANSI C63.26 2015 Power Meas. License Digital Systems with maximum output power. Radiated measurements are performed by rotating the EUT in three different ortho-gonal test planes to find the maximum emission.

Remark:

1. The mark “v “ means that this configuration is chosen for testing
2. The mark “--“ means that this bandwidth is not supported.
3. The device is investigated from 30MHz to 10 times of fundamental signal for radiated

ITEMS	Band	Bandwidth (MHz)						Modulation		RB #			Test Channel		
		1.4	3	5	10	15	20	QPSK	16QAM	1	Half	Full	L	M	H
RF Output Power	2	V	V	V	V	V	V	V	V	V	V	V	V	V	V
	4	V	V	V	V	V	V	V	V	V	V	V	V	V	V
	5	V	V	V	V	--	--	V	V	V	V	V	V	V	V
	12	V	V	V	V	--	--	V	V	V	V	V	V	V	V
	17	--	--	V	V	--	--	V	V	V	V	V	V	V	V
Peak-to-Average Ratio	2	--	--	--	--	--	V	V	V			V	V	V	V
	4	--	--	--	--	--	V	V	V			V	V	V	V
	5	--	--	--	V	--	--	V	V			V	V	V	V
	12	--	--	--	V	--	--	V	V			V	V	V	V
	17	--	--	--	V	--	--	V	V			V	V	V	V
99% & -26 dB Occupied Bandwidth	2	V	V	V	V	V	V	V	V	V			V	V	V
	4	V	V	V	V	V	V	V	V	V			V	V	V
	5	V	V	V	V	--	--	V	V	V			V	V	V
	12	V	V	V	V	--	--	V	V	V			V	V	V
	17	--	--	V	V	--	--	V	V	V			V	V	V
Spurious Emissions at Antenna Terminal	2	V	V	V	V	V	V	V	V	V			V	V	V
	4	V	V	V	V	V	V	V	V	V			V	V	V
	5	V	V	V	V	--	--	V	V	V			V	V	V
	12	V	V	V	V	--	--	V	V	V			V	V	V
	17	--	--	V	V	--	--	V	V	V			V	V	V
Field Strength of Spurious Radiation	2	--	--	--	--	--	V	V	--	V				V	
	4	--	--	--	--	--	V	V	--	V				V	
	5	--	--	--	V	--	--	V	--	V				V	
	12	--	--	--	V	--	--	V	--	V				V	
	17	--	--	--	V	--	--	V	--	V				V	

Out of band emission Band Edge	2	V	V	V	V	V	V	V	V	V	V	V	V	V
	4	V	V	V	V	V	V	V	V	V	V	V	V	V
	5	V	V	V	V	--	--	V	V	V	V	V	V	V
	12	V	V	V	V	--	--	V	V	V	V	V	V	V
	17	--	--	V	V	--	--	V	V	V	V	V	V	V
Frequency stability	2	--	--	--	--	--	V	V	V	V	V	V	V	V
	4	--	--	--	--	--	V	V	V	V	V	V	V	V
	5	--	--	--	V	--	--	V	V	V	V	V	V	V
	12	--	--	--	V	--	--	V	V	V	V	V	V	V
	17	--	--	--	V	--	--	V	V	V	V	V	V	V

Note: (1) During the testing procedure, the EUT is in link mode with base station emulator at maximum power level in each test mode.

(2) The EUT is considered a portable unit; it was pre-tested on the positioned of each 3 axis, X-plane, Y-plane and Z-plane. The worst case was found positioned on Z-plane as the normal use. Therefore only the test data of this Z-plane was used for radiated emission measurement test.

1.6 Measurement Uncertainty

Test Item	Parameters	Expanded Uncertainty (U _{Lab})
RF Power, conducted	/	±0.82 dB
Radiated Emission	Level Accuracy: 9kHz to 30 MHz	±4.60 dB
Radiated Emission	Level Accuracy: 30MHz to 1000 MHz	±4.40 dB
Radiated Emission	Level Accuracy: Above 1000MHz	±4.20 dB

1.7 Test Facility

The testing report were performed by the Shenzhen Toby Technology Co., Ltd., in their facilities located at 1A/F., Bldg.6, Yusheng Industrial Zone, The National Road No.107 Xixiang Section 467, Xixiang, Bao'an, Shenzhen, Guangdong, China. At the time of testing, the following bodies accredited the Laboratory:

CNAS (L5813)

The Laboratory has been accredited by CNAS to ISO/IEC 17025: 2017 General Requirements for the Competence of Testing and Calibration Laboratories for the competence in the field of testing. And the Registration No.: CNAS L5813.

A2LA Certificate No.: 4750.01

The laboratory has been accredited by American Association for Laboratory Accreditation(A2LA) to ISO/IEC 17025: 2017 General Requirements for the Competence of Testing and Calibration Laboratories for the technical competence in the field of Electrical Testing. And the A2LA Certificate No.: 4750.01.FCC Accredited Test Site Number: 854351. Designation Number: CN1223.

IC Registration No.: (11950A)

The Laboratory has been registered by Certification and Engineering Bureau of Industry Canada for radio equipment testing. The site registration: Site# 11950A. CAB identifier: CN0056.

2. Test Summary

Test Item	Section in CFR 47	Result
RF Output Power	Part 2.1046 Part 22.913(a)(2) Part 24.232(c) Part 27.50 (b)(10) Part 27.50 (d)(4) Part 27.50 (h)(2)	PASS
Peak-to-Average Ratio	Part 24.232(d) Part 27.50(d)(5)	PASS
99% & -26 dB Occupied Bandwidth	Part 2.1049 Part 22.917(a) Part 24.238(b) Part 27.53(h) Part 27.53(m)	PASS
Spurious Emissions at Antenna Terminal	Part 2.1051 Part 24.238(a) Part 27.53 (h) Part 27.53(m)	PASS
Field Strength of Spurious Radiation	Part 2.1053 Part 22.917(a) Part 24.238(a) Part 27.53 (h) Part 27.53(m)	PASS
Out of band emission, Band Edge	Part 24.238(a) Part 22.917(a) Part 27.53 (h) Part 27.53(m)	PASS
Frequency stability vs. temperature	Part 27.54 Part 24.235 Part 22.355 Part 2.1055(a)(1)(b)	PASS
Frequency stability vs. voltage	Part 27.54 Part 24.235 Part 22.355 Part 2.1055(d)(2)	PASS

Pass: The EUT complies with the essential requirements in the standard.

3. Test Equipment

Radiation Emission Test					
Equipment	Manufacturer	Model No.	Serial No.	Last Cal.	Cal. Due Date
Spectrum Analyzer	Agilent	E4407B	MY45106456	Jul. 02, 2021	Jul. 01, 2022
EMI Test Receiver	Rohde & Schwarz	ESPI	100010/007	Jul. 02, 2021	Jul. 01, 2022
Spectrum Analyzer	Rohde & Schwarz	FSV40-N	102197	Jul. 02, 2021	Jul. 01, 2022
Wideband Radio Communication Tester	Rohde & Schwarz	CMW500	144382	Jul. 02, 2021	Jul. 01, 2022
Universal Radio Communication Tester	Rohde&Schwarz	CMU200	103903	Jul. 02, 2021	Jul. 01, 2022
Bilog Antenna	ETS-LINDGREN	3142E	00117537	Mar.01, 2020	Feb. 28, 2022
Horn Antenna	ETS-LINDGREN	3117	00143207	Mar.01, 2020	Feb. 28, 2022
Horn Antenna	ETS-LINDGREN	BBHA 9170	BBHA9170582	Mar.01, 2020	Feb. 28, 2022
Loop Antenna	SCHWARZBECK	FMZB 1519 B	1519B-059	Jul. 07, 2020	Jul. 06, 2021
Pre-amplifier	Sonoma	310N	185903	Jul. 06, 2021	Jul. 05, 2022
Pre-amplifier	HP	8449B	3008A00849	Feb. 25, 2021	Feb. 24, 2022
Pre-amplifier	SKET	LNPA_1840G-50	SK201904032	Feb. 25, 2021	Feb. 24, 2022
Cable	HUBER+SUHNER	100	SUCOFLEX	Feb. 25, 2021	Feb. 24, 2022
Positioning Controller	ETS-LINDGREN	2090	N/A	N/A	N/A
Antenna Conducted Emission					
Equipment	Manufacturer	Model No.	Serial No.	Last Cal.	Cal. Due Date
Spectrum Analyzer	Agilent	E4407B	MY45106456	Jul. 02, 2021	Jul. 01, 2022
Wideband Radio Communication Tester	Rohde & Schwarz	CMW500	144382	Jul. 02, 2021	Jul. 01, 2022
Universal Radio Communication Tester	Rohde&Schwarz	CMU200	103903	Jul. 02, 2021	Jul. 01, 2022
Spectrum Analyzer	Rohde & Schwarz	ESPI	100010/007	Jul. 02, 2021	Jul. 01, 2022
MXA Signal Analyzer	Agilent	N9020A	MY49100060	Sep. 10, 2021	Sep. 09, 2022
Vector Signal Generator	Agilent	N5182A	MY50141294	Sep. 10, 2021	Sep. 09, 2022
Analog Signal Generator	Agilent	N5181A	MY50141953	Sep. 10, 2021	Sep. 09, 2022
RF Power Sensor	DARE!! Instruments	RadiPowerRPR3006W	17100015SNO26	Sep. 10, 2021	Sep. 09, 2022
	DARE!! Instruments	RadiPowerRPR3006W	17100015SNO29	Sep. 10, 2021	Sep. 09, 2022
	DARE!! Instruments	RadiPowerRPR3006W	17100015SNO31	Sep. 10, 2021	Sep. 09, 2022
	DARE!! Instruments	RadiPowerRPR3006W	17100015SNO33	Sep. 10, 2021	Sep. 09, 2022

4. Conducted RF Output Power

4.1 Test Standard and Limit

4.1.1 Test Standard

FCC part 2.1046, FCC part 22.913(a)(2),
FCC part 24.232(c), FCC Part 27.50(b)&(d),
FCC Part 27.50 (h)

4.2 Test Setup

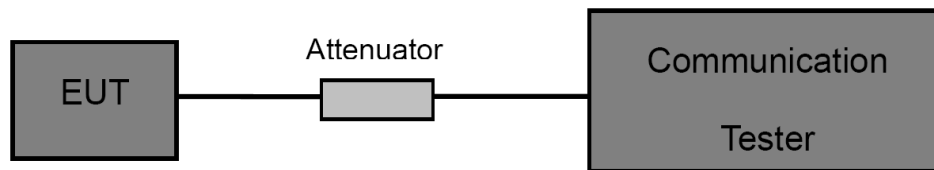

4.3 Test Procedure

- (1) The EUT is coupled to the Base Station with the suitable Attenuator, the path loss is calibrated to correct the reading.
- (2) A call is set up by the Base Station to the generic call set up procedure.
- (3) Set EUT at maximum power level through base station by power level command.
- (4) Then read record the power value from the Base Station in dBm.

4.4 EUT Operating Condition

The EUT was continuously connected with the Base station and transmitting in the max power during the test.

4.5 Deviation From Test Standard

No deviation

4.6 Test Data

Please refer to the Appendix LTE Test Data Section A-**Radiated Power Output Data**.

5. Peak-Average Ratio

5.1 Test Standard and Limit

5.1.1 Test Standard

FCC part 24.232(d)

FCC Part 27.50(d), FCC Part 27.50 (h)

5.1.2 Test Limit

Peak-to-Average Ratio

The peak-to-average ratio (PAR) of the transmission may not exceed 13 dB.

5.2 Test Setup

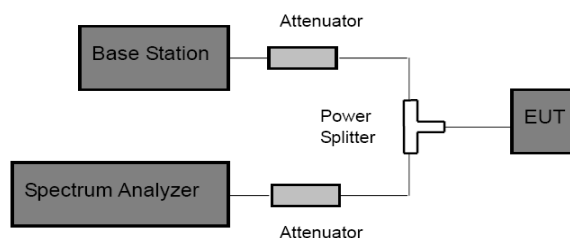

5.3 Test Procedure

According with KDB 971168

- (1) The signal analyzer's CCDF measurement profile is enabled.
- (2) Frequency = carrier center frequency.
- (3) Measurement BW > Emission bandwidth of signal.
- (4) The signal analyzer was set to collect one million samples to generate the CCDF curve.
- (5) Set the EUT working in highest power level, measured and recorded the 0.1% as PAPR level.
- (6) The measurement interval was set depending on the type of signal analyzed. For continuous signals (>98% duty cycle), the measurement interval was set to 1ms. For burst transmissions, the spectrum analyzer is set to use an internal "RF Burst" trigger that is synced with an incoming pulse and the measurement interval is set to less than the duration of the "on time" of one burst to ensure that energy is only captured during a time in which of the transmitter is operating at maximum power.

5.4 EUT Operating Condition

The EUT was continuously connected with the Base station and transmitting in the max power during the test.

5.5 Deviation From Test Standard

No deviation

5.6 Test Data

Please refer to the Appendix LTE Test Data Section B- **Peak-to-Average Ratio**

6. Occupied Bandwidth

6.1 Test Standard and Limit

6.1.1 Test Standard

FCC Part 2: 2.1049, FCC Part 22.917(a),
FCC part 24.238(b)
FCC Part 27.53(h)
FCC Part 27.53(m)

6.1.2 Test Requirement

According to FCC section 2.1049, the occupied bandwidth is the frequency bandwidth such that below its lower and above its upper frequency limits, the mean powers radiated are each equal to 0.5 percent of the total mean power radiated by a given emission.

Occupied bandwidth is also known as 99% power and -26dBC occupied bandwidths.

6.2 Test Setup

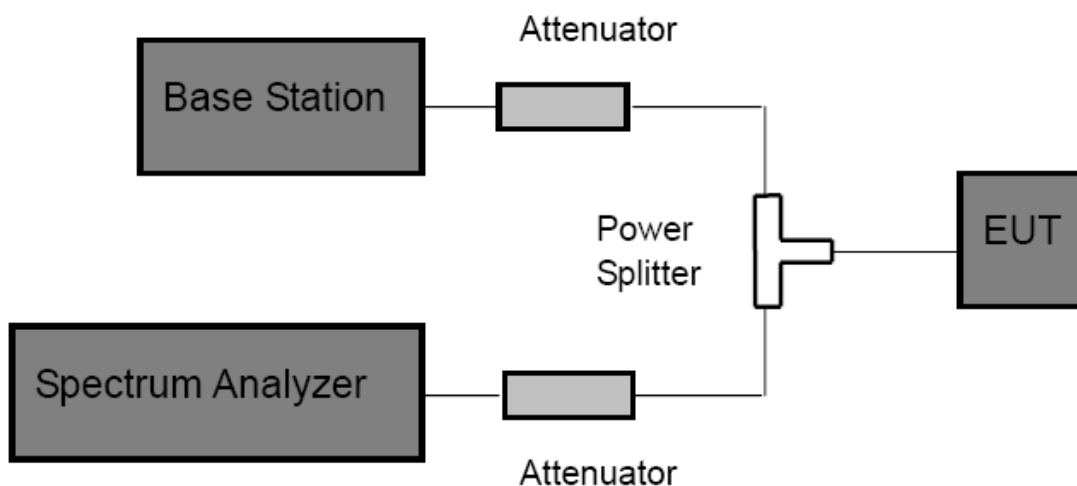

6.3 Test Procedure

- (1) The EUT was directly connected to the spectrum analyzer and Base station via power splitter as show in the block diagram above.
- (2) The resolution bandwidth of the Spectrum Analyzer is set to at least 1% of the occupied bandwidth. VBW= 3 times RBW.
- (3) The low, middle and the high channels are selected to perform tests respectively.
- (4) Set the frequency range of the Spectrum Analyzer suitably to capture the waveform; search peak; make a line whose value is 26dB lower than the peak; mark two points which the line intersected the waveform at; finally record the delta of the two points as the occupied bandwidth and the plot.
- (5) Set the Spectrum Analyzer Occupied bandwidth function to measure the 99% occupied bandwidth.

6.4 EUT Operating Condition

The EUT was continuously connected with the Base station and transmitting in the max power during the test.

6.5 Deviation From Test Standard

No deviation

6.6 Test Data

Please refer to the Appendix LTE Test Data Section C- **26dB Bandwidth and Occupied Bandwidth**

7. Out of Band Emission at Antenna Terminals

7.1 Test Standard and Limit

7.1.1 Test Standard

FCC Part 2: 2.1051, 2.1057
FCC Part 22.917(a), FCC part 24.238(a)
FCC Part 27.53 (h), FCC Part 27.53(m)

7.1.2 Test Limit

Band 7: For mobile digital stations, the attenuation factor shall be not less than $40 + 10 \log (P)$ dB on all frequencies between the channel edge and 5 megahertz from the channel edge, $43 + 10 \log (P)$ dB on all frequencies between 5 megahertz and X megahertz from the channel edge, and $55 + 10 \log (P)$ dB on all frequencies more than X megahertz from the channel edge, where X is the greater of 6 megahertz or the actual emission bandwidth as defined in paragraph (m)(6) of this section. In addition, the attenuation factor shall not be less that $43 + 10 \log (P)$ dB on all frequencies between 2490.5 MHz and 2496 MHz and $55 + 10 \log (P)$ dB at or below 2490.5 MHz. The power of any emission outside of the authorized operating frequency ranges must be attenuated below the transmitting power(P) by a factor of at least $43 + 10 \log (P)$ dB. For all power levels +30 dBm to 0 dBm, this becomes a constant specification limit of -13 dBm.

7.2 Test Setup

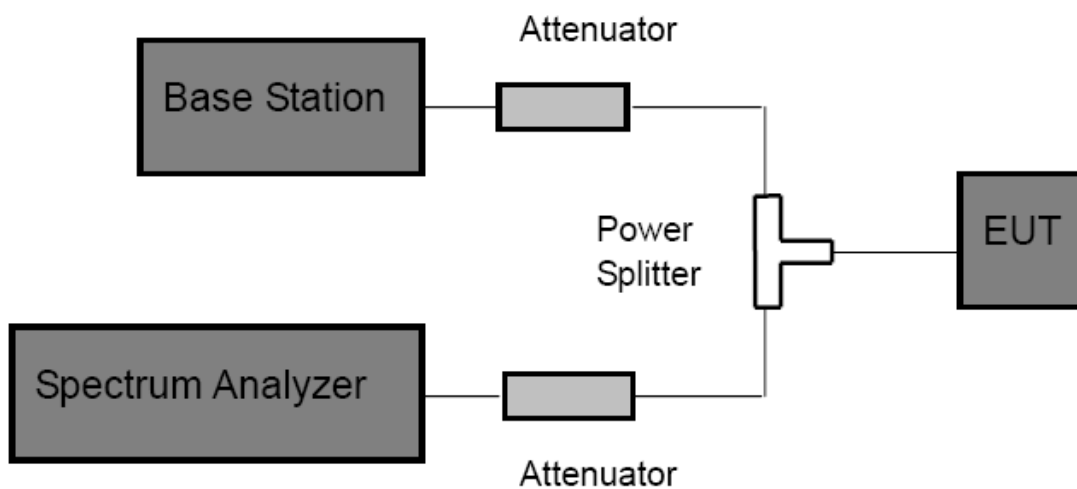

7.3 Test Procedure

- 1 The RF output of the transceiver was connected to a spectrum analyzer through appropriate attenuation.
- 2 The resolution bandwidth of the spectrum analyzer was set at 100 kHz when below 1GHz, 1MHz when above 1 GHz; sufficient scans were taken to show the out of band Emissions if any up to 10th harmonic.
- 3 For the out of band: Set the RBW=100 kHz, VBW=300 kHz when below 1 GHz, RBW =1 MHz, VBW=3 MHz when above 1 GHz, Start=30MHz, Stop= 10th harmonic.
- 4 Band Edge Requirements: In the 1 MHz bands immediately outside and adjacent to the frequency block, a resolution bandwidth of at least 1 percent of the emission bandwidth of the fundamental emission of the transmitter.

7.4 EUT Operating Condition

The EUT was continuously connected with the Base station and transmitting in the max power during the test.

7.5 Deviation From Test Standard

No deviation

7.6 Test Data

Please refer to the Appendix LTE Test Data Section E- **Conducted Spurious Emission**

8. Band Edge Test

8.1 Test Standard and Limit

8.1.1 Test Standard

FCC Part 2: 2.1051, 2.1057
FCC Part 22.917(a), FCC part 24.238(a)
FCC Part 27.53 (h), FCC Part 27.53(m)

8.1.2 Test Limit

Band 7: For mobile digital stations, the attenuation factor shall be not less than $40 + 10 \log (P)$ dB on all frequencies between the channel edge and 5 megahertz from the channel edge, $43 + 10 \log (P)$ dB on all frequencies between 5 megahertz and X megahertz from the channel edge, and $55 + 10 \log (P)$ dB on all frequencies more than X megahertz from the channel edge, where X is the greater of 6 megahertz or the actual emission bandwidth as defined in paragraph (m)(6) of this section. In addition, the attenuation factor shall not be less that $43 + 10 \log (P)$ dB on all frequencies between 2490.5 MHz and 2496 MHz and $55 + 10 \log (P)$ dB at or below 2490.5 MHz. The power of any emission outside of the authorized operating frequency ranges must be attenuated below the transmitting power(P) by a factor of at least $43+10\log(P)$ dB. For all power levels +30 dBm to 0 dBm, this becomes a constant specification limit of -13 dBm.

8.2 Test Setup

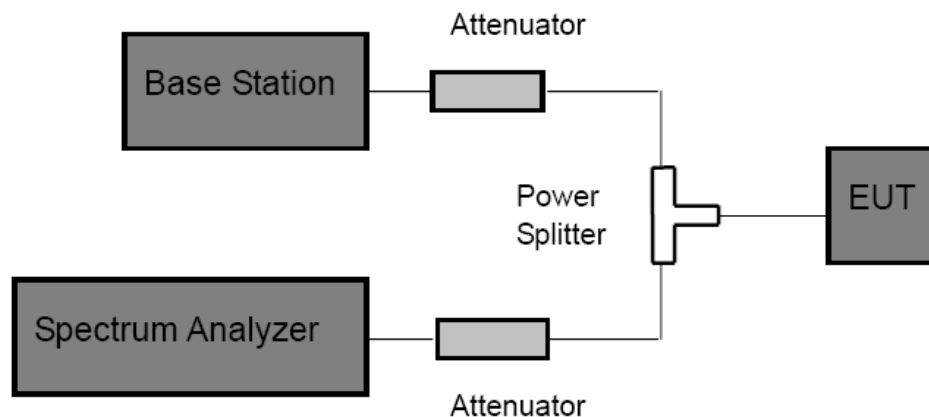

8.3 Test Procedure

- (1) The EUT was directly connected to the spectrum analyzer and Base station via power splitter as show in the block diagram above.
- (2) Band Edge Requirements: In the 1 MHz bands immediately outside and adjacent to the frequency block, a resolution bandwidth of at least 1 percent of the emission bandwidth of the fundamental emission of the transmitter.

8.4 EUT Operating Condition

The EUT was continuously connected with the Base station and transmitting in the max power during the test.

8.5 Deviation From Test Standard

No deviation

8.6 Test Data

Please refer to the Appendix LTE Test Data Section D- **Band Edge**

9. Radiated Output Power

9.1 Test Standard and Limit

9.1.1 Test Standard

FCC Part 2.1046, FCC Part 22.913(a)(2),
FCC part 24.232(c)
FCC part 27.50(c), FCC part 27.50(d)

9.1.2 Test Limit

E.I.R.P	E.I.R.P	E.R.P	E.I.R.P
LTE Band 2	LTE Band 4	LTE Band 5	LTE Band 7
2W(33 dBm)	1W(30 dBm)	7W(38.45dBm)	2W(33 dBm)
E.R.P	E.R.P	E.I.R.P	E.R.P
LTE Band 12	LTE Band 17	LTE Band 25	LTE Band 26
3W(34.77dBm)	3W(34.77dBm)	2W(33 dBm)	7W(38.45dBm)

9.2 Test Setup

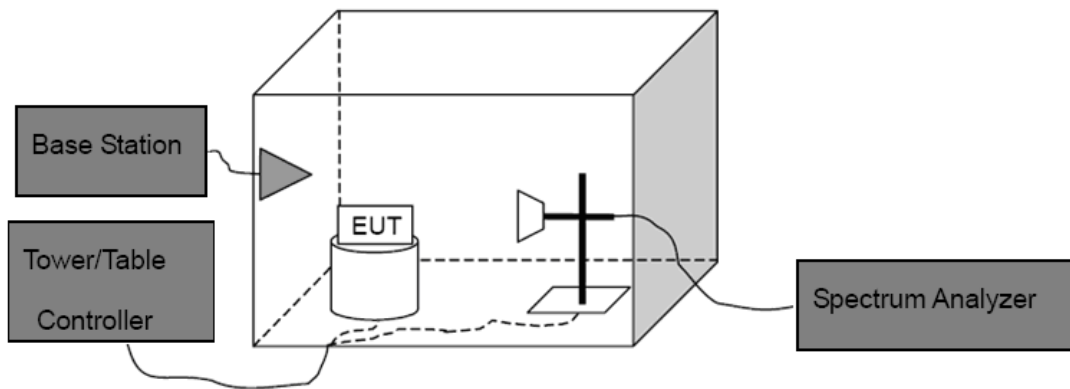

Above 1G

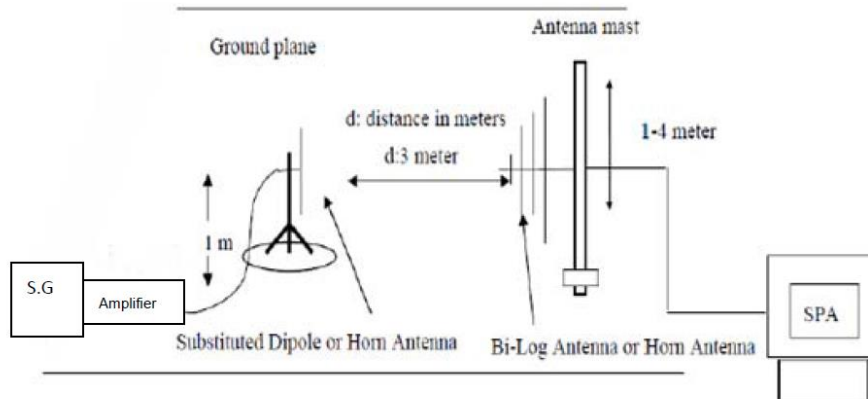

Substituted Method

9.3 Test Procedure

- (1) The EUT was placed on a non-conductive rotating platform with 0.8 meter height in an anechoic chamber. The radiated emission at the fundamental frequency was measured at 3 m with a test antenna and a spectrum analyzer with RBW=3 MHz, VBW=3 MHz and peak detector settings.
- (2) During the measurement, the EUT was enforced in maximum power and linked with the Base Station. The highest was recorded from analyzer power level (LVT) from the 360 degrees rotation of the turntable and the test antenna raised and lowered over a range from 1 to 4 meters in both horizontally and vertically polarized orientations.
- (3) Effective Isotropic Radiated Power (EIRP) was measured by substitution method according to C63.26. The EUT was replaced by dipole antenna (for frequency below 1 GHz) or Horn antenna (for frequency above 1 GHz) at same location with same polarize of receiver antenna and then a known power of each measure frequency from S.G. was applied into the dipole antenna or Horn antenna through a TX cable, and then recorded the maximum Analyzer reading through raised and lowered the test antenna.

Note: In test, the S.G Connect the Pre-amplifier(Sonoma 310N Pre-amplifier for frequency below 1 GHz, HP 8449B Pre-amplifier for frequency above 1 GHz)

Then the EUT's EIRP and ERP was calculated with the correction factor:

$ERP = S.G.Level + Antenna Gain Cord.(dB) - Cable Loss(dB)$

$EIRP = S.G.Level + Antenna Gain Cord.(dBi) - Cable Loss(dB)$

9.4 EUT Operating Condition

The EUT was continuously connected with the Base station and transmitting in the max power during the test.

9.5 Deviation From Test Standard

No deviation

9.6 Test Data

Please refer to the Attachment F.
Measurement Data (worst case)

10. Radiated Out Band of Emissions

10.1 Test Standard and Limit

10.1.1 Test Standard

FCC Part 2: 2.1053, FCC Part 22.917(a)
FCC part 24.238(a)
FCC Part 27.53 (h), FCC Part 27.53(m)

10.1.2 Test Limit

The power of any emission outside of the authorized operating frequency ranges must be attenuated below the transmitting power(P) by a factor of at least $43+10\log(P)$ dB. For all power levels +30 dBm to 0 dBm, this becomes a constant specification limit of -13 dBm.

10.2 Test Setup

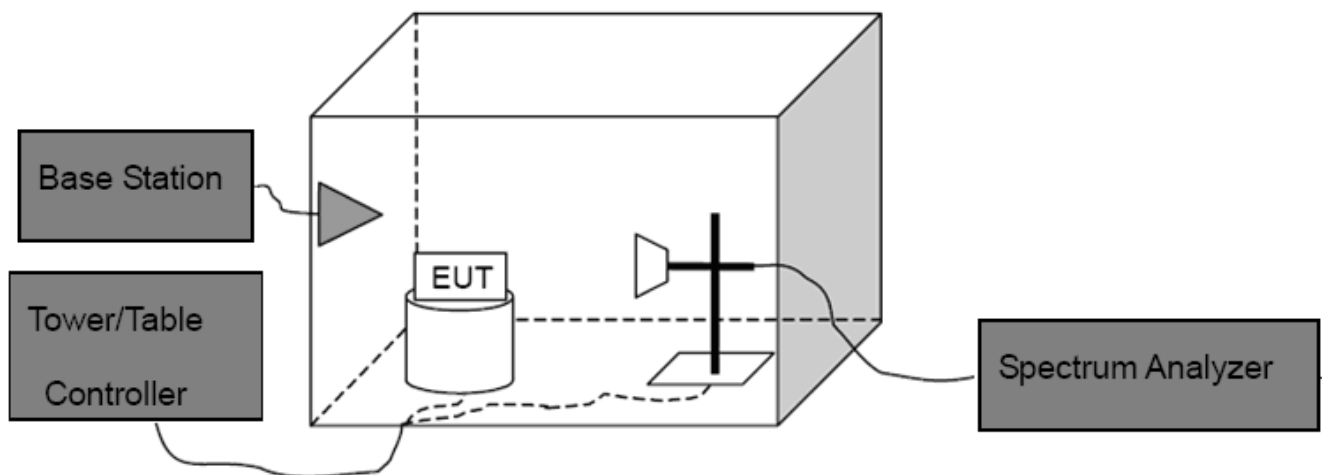

10.3 Test Procedure

- (1) The test system setup as show in the block diagram above.
- (2) The EUT was placed on an non-conductive rotating platform in an anechoic chamber. The radiated spurious emissions from 30MHz to 10th harmonious of fundamental frequency were measured at 3 m with a test antenna and a spectrum analyzer with RBW=1 MHz, VBW=1 MHz, peak detector settings.
- (3) During the measurement, the EUT was enforced in maximum power and linked with a base station. All the spurious emissions at 3m were measured by rotation of the turntable and the test antenna raised and lowered over a range from 1 to 4 meters in both horizontally and vertically polarized orientations.
- (4) When found the maximum level of emissions from the EUT. Remove the EUT and replace it with substitution antenna. A signal generator was connected to the substitution antenna by a non-radiating cable. The absolute levels of the spurious emissions were measured by the substitution.

Spurious emissions in dB=10 log(TX power in Watts/0.001)-the absolute level

Spurious attenuation limit in dB= $43+10 \log(\text{power out in Watts})$

10.4 EUT Operating Condition

The EUT was continuously connected with the Base station and transmitting in the max power during the test.

10.5 Deviation From Test Standard

No deviation

10.6 Test Data

Please refer to the Attachment G.
Measurement Data (worst case)

11. Frequency Stability

11.1 Test Standard and Limit

11.1.1 Test Standard

FCC Part 2.1055(a)(1)(b) FCC Part 22.355

FCC Part 24.235, Part 27.54

11.1.2 Limit

Limit
±2.5ppm

11.2 Test Setup

For Temperature Test:

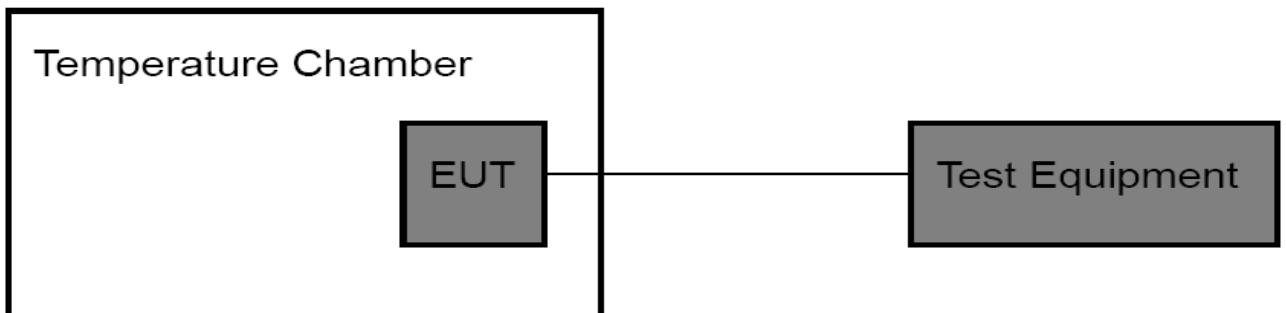

For Voltage Test:

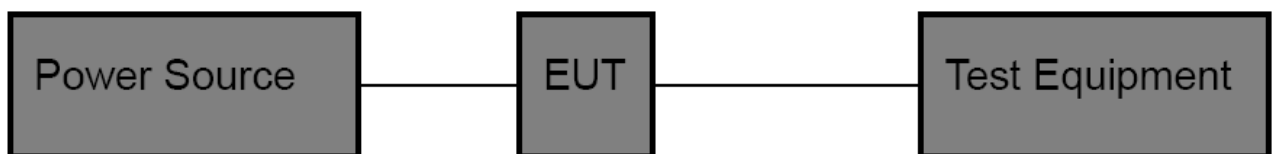

11.3 Test Procedure

Test Procedures for Temperature Variation:

- (1) The EUT was set up in the thermal chamber and connected with the base station.
- (2) With power off, the temperature was decreased to -30°C and the EUT was stabilized for three hours. Power was applied and the maximum change in frequency was recorded within one minute.
- (3) With power off, the temperature was raised in 10°C set up to 50°C and the EUT was stabilized for three hours. Power was applied and the maximum change in frequency was recorded within one minute.
- (4) If the EUT cannot be turned on at -30°C , the testing lowest temperature will be raised in 10°C step until the EUT can be turned on.

Test Procedures for Voltage Variation:

- (1) The EUT was placed in a temperature chamber at $25 \pm 5^{\circ}\text{C}$ and connected with the base station.
- (2) Reduce the input voltage to specify extreme voltage variation ($\pm 15\%$) and endpoint, record the maximum frequency change.
- (3) The variation in frequency was measured for the worst case.

11.4 EUT Operating Condition

The Equipment Under Test was set to Communication with the Base Station.

11.5 Deviation From Test Standard

No deviation

11.6 Test Data

Please refer to the Appendix LTE Test Data Section F- **Frequency Stability**

ATTACHMENT F--RADIATED OUTPUT POWER

Radiated Power (EIRP) for LTE Band 2 / 1.4M									
Modulation	RB		Channel	Antenna (H&V)	SG Level (dBm)	Antenna Factor (dB)	Cable Loss (dB)	EIRP (dBm)	EIRP (W)
	Size	offset							
QPSK	1	0	Lowest	H	19.11	5.01	2.59	21.53	0.142
				V	16.83	5.01	2.59	19.25	0.084
	1	0	Middle	H	19.96	4.82	2.59	22.19	0.166
				V	16.60	4.82	2.59	18.83	0.076
	1	0	Highest	H	20.16	4.45	2.59	22.02	0.159
				V	17.11	4.45	2.59	18.97	0.079
16QAM	1	0	Lowest	H	19.35	5.01	2.59	21.77	0.150
				V	16.20	5.01	2.59	18.62	0.073
	1	0	Middle	H	19.58	4.82	2.59	21.81	0.152
				V	16.92	4.82	2.59	19.15	0.082
	1	0	Highest	H	20.48	4.45	2.59	22.34	0.172
				V	17.09	4.45	2.59	18.95	0.079
Limit								33	2

Radiated Power (EIRP) for LTE Band 2 / 3M									
Modulation	RB		Channel	Antenna (H&V)	SG Level (dBm)	Antenna Factor (dB)	Cable Loss (dB)	EIRP (dBm)	EIRP (W)
	Size	offset							
QPSK	1	0	Lowest	H	19.45	5.01	2.59	21.87	0.154
				V	16.07	5.01	2.59	18.49	0.071
	1	0	Middle	H	19.81	4.82	2.59	22.04	0.160
				V	16.80	4.82	2.59	19.03	0.080
	1	0	Highest	H	20.30	4.45	2.59	22.16	0.164
				V	17.07	4.45	2.59	18.93	0.078
16QAM	1	0	Lowest	H	18.93	5.01	2.59	21.35	0.136
				V	16.26	5.01	2.59	18.68	0.074
	1	0	Middle	H	19.90	4.82	2.59	22.13	0.163
				V	16.40	4.82	2.59	18.63	0.073
	1	0	Highest	H	20.41	4.45	2.59	22.27	0.169
				V	16.54	4.45	2.59	18.40	0.069
Limit								33	2

Radiated Power (EIRP) for LTE Band 2 / 5M									
Modulation	RB		Channel	Antenna (H&V)	SG Level (dBm)	Antenna Factor (dB)	Cable Loss (dB)	EIRP (dBm)	EIRP (W)
	Size	offset							
QPSK	1	0	Lowest	H	19.33	5.01	2.59	21.75	0.150
				V	16.24	5.01	2.59	18.66	0.073
	1	0	Middle	H	19.36	4.82	2.59	21.59	0.144
				V	16.66	4.82	2.59	18.89	0.077
	1	0	Highest	H	20.05	4.45	2.59	21.91	0.155
				V	16.77	4.45	2.59	18.63	0.073
16QAM	1	0	Lowest	H	19.33	5.01	2.59	21.75	0.150
				V	16.40	5.01	2.59	18.82	0.076
	1	0	Middle	H	19.45	4.82	2.59	21.68	0.147
				V	16.49	4.82	2.59	18.72	0.074
	1	0	Highest	H	20.23	4.45	2.59	22.09	0.162
				V	16.76	4.45	2.59	18.62	0.073
Limit								33	2

Radiated Power (EIRP) for LTE Band 2 / 10M									
Modulation	RB		Channel	Antenna (H&V)	SG Level (dBm)	Antenna Factor (dB)	Cable Loss (dB)	EIRP (dBm)	EIRP (W)
	Size	offset							
QPSK	1	0	Lowest	H	19.04	5.01	2.59	21.46	0.140
				V	16.97	5.01	2.59	19.39	0.087
	1	0	Middle	H	19.43	4.82	2.59	21.66	0.147
				V	15.64	4.82	2.59	17.87	0.061
	1	0	Highest	H	20.05	4.45	2.59	21.91	0.155
				V	16.33	4.45	2.59	18.19	0.066
16QAM	1	0	Lowest	H	18.94	5.01	2.59	21.36	0.137
				V	15.95	5.01	2.59	18.37	0.069
	1	0	Middle	H	19.13	4.82	2.59	21.36	0.137
				V	16.17	4.82	2.59	18.40	0.069
	1	0	Highest	H	19.20	4.45	2.59	21.06	0.128
				V	16.59	4.45	2.59	18.45	0.070
Limit								33	2

Radiated Power (EIRP) for LTE Band 2 / 15M									
Modulation	RB		Channel	Antenna (H&V)	SG Level (dBm)	Antenna Factor (dB)	Cable Loss (dB)	EIRP (dBm)	EIRP (W)
	Size	offset							
QPSK	1	0	Lowest	H	18.59	5.01	2.59	21.01	0.126
				V	15.71	5.01	2.59	18.13	0.065
	1	0	Middle	H	19.39	4.82	2.59	21.62	0.145
				V	15.96	4.82	2.59	18.19	0.066
	1	0	Highest	H	19.71	4.45	2.59	21.57	0.143
				V	16.11	4.45	2.59	17.97	0.063
16QAM	1	0	Lowest	H	18.97	5.01	2.59	21.39	0.138
				V	16.15	5.01	2.59	18.57	0.072
	1	0	Middle	H	19.45	4.82	2.59	21.68	0.147
				V	16.35	4.82	2.59	18.58	0.072
	1	0	Highest	H	19.28	4.45	2.59	21.14	0.130
				V	16.73	4.45	2.59	18.59	0.072
Limit								33	2

Radiated Power (EIRP) for LTE Band 2 / 20M									
Modulation	RB		Channel	Antenna (H&V)	SG Level (dBm)	Antenna Factor (dB)	Cable Loss (dB)	EIRP (dBm)	EIRP (W)
	Size	offset							
QPSK	1	0	Lowest	H	18.86	5.01	2.59	21.28	0.134
				V	15.32	5.01	2.59	17.74	0.059
	1	0	Middle	H	19.54	4.82	2.59	21.77	0.150
				V	16.35	4.82	2.59	18.58	0.072
	1	0	Highest	H	19.76	4.45	2.59	21.62	0.145
				V	16.53	4.45	2.59	18.39	0.069
16QAM	1	0	Lowest	H	19.44	5.01	2.59	21.86	0.154
				V	15.31	5.01	2.59	17.73	0.059
	1	0	Middle	H	19.12	4.82	2.59	21.35	0.137
				V	16.01	4.82	2.59	18.24	0.067
	1	0	Highest	H	19.49	4.45	2.59	21.35	0.136
				V	15.87	4.45	2.59	17.73	0.059
Limit								33	2

Radiated Power (EIRP) for LTE Band 4 / 1.4M									
Modulation	RB		Channel	Antenna (H&V)	SG Level (dBm)	Antenna Factor (dB)	Cable Loss (dB)	EIRP (dBm)	EIRP (W)
	Size	offset							
QPSK	1	0	Lowest	H	18.47	5.26	2.43	21.30	0.135
				V	15.76	5.26	2.43	18.59	0.072
	1	0	Middle	H	18.87	5.38	2.43	21.82	0.152
				V	16.00	5.38	2.43	18.95	0.079
	1	0	Highest	H	18.79	5.4	2.43	21.76	0.150
				V	15.21	5.4	2.43	18.18	0.066
16QAM	1	0	Lowest	H	19.33	5.26	2.43	22.16	0.164
				V	15.83	5.26	2.43	18.66	0.073
	1	0	Middle	H	18.55	5.38	2.43	21.50	0.141
				V	15.73	5.38	2.43	18.68	0.074
	1	0	Highest	H	17.98	5.4	2.43	20.95	0.124
				V	15.14	5.4	2.43	18.11	0.065
Limit								30	1

Radiated Power (EIRP) for LTE Band 4 / 3M									
Modulation	RB		Channel	Antenna (H&V)	SG Level (dBm)	Antenna Factor (dB)	Cable Loss (dB)	EIRP (dBm)	EIRP (W)
	Size	offset							
QPSK	1	0	Lowest	H	18.39	5.26	2.43	21.22	0.133
				V	15.01	5.26	2.43	17.84	0.061
	1	0	Middle	H	18.55	5.38	2.43	21.50	0.141
				V	15.78	5.38	2.43	18.73	0.075
	1	0	Highest	H	18.64	5.4	2.43	21.61	0.145
				V	16.03	5.4	2.43	19.00	0.080
16QAM	1	0	Lowest	H	19.08	5.26	2.43	21.91	0.155
				V	15.75	5.26	2.43	18.58	0.072
	1	0	Middle	H	18.19	5.38	2.43	21.14	0.130
				V	14.70	5.38	2.43	17.65	0.058
	1	0	Highest	H	18.54	5.4	2.43	21.51	0.142
				V	15.64	5.4	2.43	18.61	0.073
Limit								30	1

Radiated Power (EIRP) for LTE Band 4 / 5M									
Modulation	RB		Channel	Antenna (H&V)	SG Level (dBm)	Antenna Factor (dB)	Cable Loss (dB)	EIRP (dBm)	EIRP (W)
	Size	offset							
QPSK	1	0	Lowest	H	18.27	5.26	2.43	21.10	0.129
				V	15.43	5.26	2.43	18.26	0.067
	1	0	Middle	H	18.77	5.38	2.43	21.72	0.149
				V	15.40	5.38	2.43	18.35	0.068
	1	0	Highest	H	18.18	5.4	2.43	21.15	0.130
				V	14.96	5.4	2.43	17.93	0.062
16QAM	1	0	Lowest	H	18.78	5.26	2.43	21.61	0.145
				V	15.46	5.26	2.43	18.29	0.067
	1	0	Middle	H	19.12	5.38	2.43	22.07	0.161
				V	15.82	5.38	2.43	18.77	0.075
	1	0	Highest	H	18.63	5.4	2.43	21.60	0.145
				V	15.60	5.4	2.43	18.57	0.072
Limit								30	1

Radiated Power (EIRP) for LTE Band 4 / 10M									
Modulation	RB		Channel	Antenna (H&V)	SG Level (dBm)	Antenna Factor (dB)	Cable Loss (dB)	EIRP (dBm)	EIRP (W)
	Size	offset							
QPSK	1	0	Lowest	H	18.23	5.26	2.43	21.06	0.128
				V	14.63	5.26	2.43	17.46	0.056
	1	0	Middle	H	18.38	5.38	2.43	21.33	0.136
				V	15.46	5.38	2.43	18.41	0.069
	1	0	Highest	H	18.70	5.4	2.43	21.67	0.147
				V	14.84	5.4	2.43	17.81	0.060
16QAM	1	0	Lowest	H	19.16	5.26	2.43	21.99	0.158
				V	15.80	5.26	2.43	18.63	0.073
	1	0	Middle	H	18.31	5.38	2.43	21.26	0.134
				V	15.55	5.38	2.43	18.50	0.071
	1	0	Highest	H	18.32	5.4	2.43	21.29	0.135
				V	15.70	5.4	2.43	18.67	0.074
Limit								30	1

Radiated Power (EIRP) for LTE Band 4 / 15M									
Modulation	RB		Channel	Antenna (H&V)	SG Level (dBm)	Antenna Factor (dB)	Cable Loss (dB)	EIRP (dBm)	EIRP (W)
	Size	offset							
QPSK	1	0	Lowest	H	18.13	5.26	2.43	20.96	0.125
				V	15.23	5.26	2.43	18.06	0.064
	1	0	Middle	H	17.92	5.38	2.43	20.87	0.122
				V	15.08	5.38	2.43	18.03	0.063
	1	0	Highest	H	18.44	5.4	2.43	21.41	0.138
				V	15.31	5.4	2.43	18.28	0.067
16QAM	1	0	Lowest	H	18.24	5.26	2.43	21.07	0.128
				V	15.71	5.26	2.43	18.54	0.072
	1	0	Middle	H	17.94	5.38	2.43	20.89	0.123
				V	14.46	5.38	2.43	17.41	0.055
	1	0	Highest	H	18.85	5.4	2.43	21.82	0.152
				V	15.38	5.4	2.43	18.35	0.068
Limit								30	1

Radiated Power (EIRP) for LTE Band 4 / 20M									
Modulation	RB		Channel	Antenna (H&V)	SG Level (dBm)	Antenna Factor (dB)	Cable Loss (dB)	EIRP (dBm)	EIRP (W)
	Size	offset							
QPSK	1	0	Lowest	H	18.40	5.26	2.43	21.23	0.133
				V	14.69	5.26	2.43	17.52	0.056
	1	0	Middle	H	18.66	5.38	2.43	21.61	0.145
				V	15.59	5.38	2.43	18.54	0.071
	1	0	Highest	H	18.55	5.4	2.43	21.52	0.142
				V	15.89	5.4	2.43	18.86	0.077
16QAM	1	0	Lowest	H	19.04	5.26	2.43	21.87	0.154
				V	15.92	5.26	2.43	18.75	0.075
	1	0	Middle	H	18.64	5.38	2.43	21.59	0.144
				V	15.76	5.38	2.43	18.71	0.074
	1	0	Highest	H	18.88	5.4	2.43	21.85	0.153
				V	15.82	5.4	2.43	18.79	0.076
Limit								30	1

Radiated Power (ERP) for LTE Band 5 / 1.4M									
Modulation	RB		Channel	Antenna (H&V)	SG Level (dBm)	Antenna Factor (dB)	Cable Loss (dB)	ERP (dBm)	ERP (W)
	Size	offset							
QPSK	1	0	Lowest	H	18.45	4.7	1.36	21.79	0.151
				V	14.99	4.7	1.36	18.33	0.068
	1	0	Middle	H	18.05	4.83	1.36	21.52	0.142
				V	14.67	4.83	1.36	18.14	0.065
	1	0	Highest	H	16.69	5.3	1.36	20.63	0.116
				V	14.17	5.3	1.36	18.11	0.065
16QAM	1	0	Lowest	H	17.86	4.7	1.36	21.20	0.132
				V	15.08	4.7	1.36	18.42	0.069
	1	0	Middle	H	17.88	4.83	1.36	21.35	0.136
				V	14.69	4.83	1.36	18.16	0.065
	1	0	Highest	H	17.04	5.3	1.36	20.98	0.125
				V	14.19	5.3	1.36	18.13	0.065
Limit								38.45	7

Radiated Power (ERP) for LTE Band 5 / 3M									
Modulation	RB		Channel	Antenna (H&V)	SG Level (dBm)	Antenna Factor (dB)	Cable Loss (dB)	ERP (dBm)	ERP (W)
	Size	offset							
QPSK	1	0	Lowest	H	18.57	4.7	1.36	21.91	0.155
				V	14.82	4.7	1.36	18.16	0.065
	1	0	Middle	H	17.70	4.83	1.36	21.17	0.131
				V	14.76	4.83	1.36	18.23	0.066
	1	0	Highest	H	17.49	5.3	1.36	21.43	0.139
				V	14.36	5.3	1.36	18.30	0.068
16QAM	1	0	Lowest	H	18.24	4.7	1.36	21.58	0.144
				V	15.36	4.7	1.36	18.70	0.074
	1	0	Middle	H	17.98	4.83	1.36	21.45	0.140
				V	14.97	4.83	1.36	18.44	0.070
	1	0	Highest	H	17.66	5.3	1.36	21.60	0.145
				V	14.76	5.3	1.36	18.70	0.074
Limit								38.45	7

Radiated Power (ERP) for LTE Band 5 / 5M									
Modulation	RB		Channel	Antenna (H&V)	SG Level (dBm)	Antenna Factor (dB)	Cable Loss (dB)	ERP (dBm)	ERP (W)
	Size	offset							
QPSK	1	0	Lowest	H	18.26	4.7	1.36	21.60	0.144
				V	15.24	4.7	1.36	18.58	0.072
	1	0	Middle	H	18.14	4.83	1.36	21.61	0.145
				V	15.35	4.83	1.36	18.82	0.076
	1	0	Highest	H	17.35	5.3	1.36	21.29	0.135
				V	14.59	5.3	1.36	18.53	0.071
16QAM	1	0	Lowest	H	18.03	4.7	1.36	21.37	0.137
				V	15.05	4.7	1.36	18.39	0.069
	1	0	Middle	H	18.44	4.83	1.36	21.91	0.155
				V	15.08	4.83	1.36	18.55	0.072
	1	0	Highest	H	17.08	5.3	1.36	21.02	0.126
				V	14.34	5.3	1.36	18.28	0.067
Limit								38.45	7

Radiated Power (ERP) for LTE Band 5 / 10M									
Modulation	RB		Channel	Antenna (H&V)	SG Level (dBm)	Antenna Factor (dB)	Cable Loss (dB)	ERP (dBm)	ERP (W)
	Size	offset							
QPSK	1	0	Lowest	H	17.58	4.7	1.36	20.92	0.124
				V	14.46	4.7	1.36	17.80	0.060
	1	0	Middle	H	17.50	4.83	1.36	20.97	0.125
				V	14.35	4.83	1.36	17.82	0.060
	1	0	Highest	H	17.61	5.3	1.36	21.55	0.143
				V	14.31	5.3	1.36	18.25	0.067
16QAM	1	0	Lowest	H	18.13	4.7	1.36	21.47	0.140
				V	15.10	4.7	1.36	18.44	0.070
	1	0	Middle	H	18.10	4.83	1.36	21.57	0.144
				V	15.16	4.83	1.36	18.63	0.073
	1	0	Highest	H	17.72	5.3	1.36	21.66	0.147
				V	14.63	5.3	1.36	18.57	0.072
Limit								38.45	7

Radiated Power (EIRP) for LTE Band 12 / 1.4M									
Modulation	RB		Channel	Antenna (H&V)	SG Level (dBm)	Antenna Factor (dBd)	Cable Loss (dB)	EIRP (dBm)	EIRP (W)
	Size	offset							
QPSK	1	0	Lowest	H	19.77	4.76	2.65	21.88	0.154
				V	17.86	4.76	2.65	19.97	0.099
	1	0	Middle	H	19.63	4.91	2.65	21.89	0.155
				V	17.44	4.91	2.65	19.7	0.093
	1	0	Highest	H	20.12	5	2.65	22.47	0.177
				V	17.47	5	2.65	19.82	0.096
16QAM	1	0	Lowest	H	20.04	4.76	2.65	22.15	0.164
				V	17.04	4.76	2.65	19.15	0.082
	1	0	Middle	H	20.07	4.91	2.65	22.33	0.171
				V	18.00	4.91	2.65	20.26	0.106
	1	0	Highest	H	19.83	5	2.65	22.18	0.165
				V	17.05	5	2.65	19.4	0.087
Limit								34.77	3

Radiated Power (EIRP) for LTE Band 12 / 3M									
Modulation	RB		Channel	Antenna (H&V)	SG Level (dBm)	Antenna Factor (dBd)	Cable Loss (dB)	EIRP (dBm)	EIRP (W)
	Size	offset							
QPSK	1	0	Lowest	H	19.88	4.76	2.65	21.99	0.158
				V	17.80	4.76	2.65	19.91	0.098
	1	0	Middle	H	19.78	4.91	2.65	22.04	0.160
				V	17.37	4.91	2.65	19.63	0.092
	1	0	Highest	H	20.26	5	2.65	22.61	0.182
				V	17.48	5	2.65	19.83	0.096
16QAM	1	0	Lowest	H	20.03	4.76	2.65	22.14	0.164
				V	17.09	4.76	2.65	19.2	0.083
	1	0	Middle	H	20.08	4.91	2.65	22.34	0.171
				V	17.96	4.91	2.65	20.22	0.105
	1	0	Highest	H	19.85	5	2.65	22.2	0.166
				V	17.21	5	2.65	19.56	0.090
Limit								34.77	3

Radiated Power (EIRP) for LTE Band 12 /5M									
Modulation	RB		Channel	Antenna (H&V)	SG Level (dBm)	Antenna Factor (dBd)	Cable Loss (dB)	EIRP (dBm)	EIRP (W)
	Size	offset							
QPSK	1	0	Lowest	H	19.87	4.76	2.65	21.98	0.158
				V	17.77	4.76	2.65	19.88	0.097
	1	0	Middle	H	19.72	4.91	2.65	21.98	0.158
				V	17.45	4.91	2.65	19.71	0.094
	1	0	Highest	H	20.30	5	2.65	22.65	0.184
				V	17.61	5	2.65	19.96	0.099
16QAM	1	0	Lowest	H	20.00	4.76	2.65	22.11	0.163
				V	17.06	4.76	2.65	19.17	0.083
	1	0	Middle	H	20.04	4.91	2.65	22.3	0.170
				V	18.01	4.91	2.65	20.27	0.106
	1	0	Highest	H	19.89	5	2.65	22.24	0.167
				V	17.11	5	2.65	19.46	0.088
Limit								34.77	3

Radiated Power (EIRP) for LTE Band 12 /10M									
Modulation	RB		Channel	Antenna (H&V)	SG Level (dBm)	Antenna Factor (dBd)	Cable Loss (dB)	EIRP (dBm)	EIRP (W)
	Size	offset							
QPSK	1	0	Lowest	H	19.86	4.76	2.65	21.97	0.157
				V	17.80	4.76	2.65	19.91	0.098
	1	0	Middle	H	19.67	4.91	2.65	21.93	0.156
				V	17.33	4.91	2.65	19.59	0.091
	1	0	Highest	H	20.28	5	2.65	22.63	0.183
				V	17.54	5	2.65	19.89	0.097
16QAM	1	0	Lowest	H	20.06	4.76	2.65	22.17	0.165
				V	17.06	4.76	2.65	19.17	0.083
	1	0	Middle	H	20.10	4.91	2.65	22.36	0.172
				V	17.99	4.91	2.65	20.25	0.106
	1	0	Highest	H	19.87	5	2.65	22.22	0.167
				V	17.18	5	2.65	19.53	0.090
Limit								34.77	3

Radiated Power (EIRP) for LTE Band 17 / 5M									
Modulation	RB		Channel	Antenna (H&V)	SG Level (dBm)	Antenna Factor (dBd)	Cable Loss (dB)	EIRP (dBm)	EIRP (W)
	Size	offset							
QPSK	1	0	Lowest	H	19.93	4.76	2.65	22.04	0.160
				V	17.85	4.76	2.65	19.96	0.099
	1	0	Middle	H	19.69	4.91	2.65	21.95	0.157
				V	17.32	4.91	2.65	19.58	0.091
	1	0	Highest	H	20.26	5	2.65	22.61	0.182
				V	17.60	5	2.65	19.95	0.099
16QAM	1	0	Lowest	H	20.10	4.76	2.65	22.21	0.166
				V	17.15	4.76	2.65	19.26	0.084
	1	0	Middle	H	20.02	4.91	2.65	22.28	0.169
				V	18.02	4.91	2.65	20.28	0.107
	1	0	Highest	H	19.88	5	2.65	22.23	0.167
				V	17.11	5	2.65	19.46	0.088
Limit								34.77	3

Radiated Power (EIRP) for LTE Band 17 / 10M									
Modulation	RB		Channel	Antenna (H&V)	SG Level (dBm)	Antenna Factor (dBd)	Cable Loss (dB)	EIRP (dBm)	EIRP (W)
	Size	offset							
QPSK	1	0	Lowest	H	19.85	4.76	2.65	21.96	0.157
				V	17.71	4.76	2.65	19.82	0.096
	1	0	Middle	H	19.70	4.91	2.65	21.96	0.157
				V	17.35	4.91	2.65	19.61	0.091
	1	0	Highest	H	20.11	5	2.65	22.46	0.176
				V	17.58	5	2.65	19.93	0.098
16QAM	1	0	Lowest	H	20.10	4.76	2.65	22.21	0.166
				V	17.05	4.76	2.65	19.16	0.082
	1	0	Middle	H	20.10	4.91	2.65	22.36	0.172
				V	17.95	4.91	2.65	20.21	0.105
	1	0	Highest	H	19.92	5	2.65	22.27	0.169
				V	17.16	5	2.65	19.51	0.089
Limit								34.77	3

ATTACHMENT G--RADIATED OUT BAND OF EMISSIONS

Measurement Data (worst case)

Test mode: LTE BAND 2 20MHz (RB size 1 & RB offset 0) for QPSK							
Channel: Middle				Date of Test: 2022-01-11			
Frequency (MHz)	Spurious Emission					Limit (dBm)	Result
	Polarization (H&V)	Read Level (dBm)	Antenna Correct Factor (dBi)	Cable Loss (dB)	Emission Level (dBm)		
3759.90	Horizontal	-55.28	14.94	6.12	-34.22	-13.00	Pass
5640.20	H	-65.48	13.87	7.86	-43.75		
7519.60	H	-70.68	14.49	9.54	-46.65		
3759.90	Vertical	-51.01	15.97	6.12	-28.92	-13.00	Pass
5640.20	V	-61.40	13.94	7.86	-39.60		
7519.60	V	-66.93	13.87	9.54	-43.52		

Remark: 1, The testing has been conformed to $10 \times 1880\text{MHz} = 18800\text{MHz}$.
 2, All other emissions more than 30 dB below the limit.
 3, Emission Level= Read Level+ Antenna Correct Factor +Cable Loss

Test mode: LTE BAND 4 20MHz (RB size 1 & RB offset 0) for QPSK							
Channel: Middle				Date of Test: 2022-01-11			
Frequency (MHz)	Spurious Emission					Limit (dBm)	Result
	Polarization (H&V)	Read Level (dBm)	Antenna Correct Factor (dBi)	Cable Loss (dB)	Emission Level (dBm)		
3465.99	Horizontal	-52.46	14.94	6.24	-31.28	-13.00	Pass
5198.98	H	-62.30	13.87	7.98	-40.45		
6932.13	H	-65.92	14.49	9.68	-41.75		
3465.99	Vertical	-51.93	15.97	6.24	-29.72	-13.00	Pass
5198.98	V	-63.30	13.94	7.98	-41.38		
6932.13	V	-71.68	13.87	9.68	-48.13		

Remark: 1, The testing has been conformed to $10 \times 1732.5\text{MHz} = 17325\text{MHz}$.
 2, All other emissions more than 30 dB below the limit.
 3, Emission Level= Read Level+ Antenna Correct Factor +Cable Loss

Test mode: LTE BAND 5 10MHz (RB size 1 & RB offset 0) for QPSK							
Channel: Middle			Date of Test: 2022-01-11				
Frequency (MHz)	Spurious Emission					Limit (dBm)	Result
	Polarization (H&V)	Read Level (dBm)	Antenna Correct Factor (dBi)	Cable Loss (dB)	Emission Level (dBm)		
1673.00	Horizontal	-44.47	7.49	3.97	-33.01	-13.00	Pass
2509.50	H	-50.19	7.03	5.05	-38.11		
3346.00	H	-64.47	12.48	5.98	-46.01		
1673.00	Vertical	-42.31	8.02	3.97	-30.32	-13.00	Pass
2509.50	V	-57.07	10.47	5.05	-41.55		
3346.00	V	-69.23	16.92	5.98	-46.33		
Remark: 1, The testing has been conformed to $10 \times 836.5\text{MHz} = 8365\text{MHz}$. 2, All other emissions more than 30 dB below the limit. 3, Emission Level= Read Level+ Antenna Correct Factor +Cable Loss							
Test mode: LTE BAND 12 10MHz (RB size 1 & RB offset 0) for QPSK							
Channel: Middle			Date of Test: 2022-01-11				
Frequency (MHz)	Spurious Emission					Limit (dBm)	Result
	Polarization (H&V)	Read Level (dBm)	Antenna Correct Factor (dBi)	Cable Loss (dB)	Emission Level (dBm)		
5070.00	Horizontal	-59.37	7.49	7.53	-51.96	-25.00	Pass
7605.00	H	-53.15	7.03	9.26	-51.04		
10140.00	H	-52.99	12.48	11.45	-50.73		
5070.00	Vertical	-60.21	7.49	7.53	-57.95	-25.00	Pass
7605.00	V	-51.93	7.03	9.26	-49.58		
10140.00	V	-57.15	12.48	11.45	-54.8		
Remark: 1, The testing has been conformed to $10 \times 2535.0\text{MHz} = 25350\text{MHz}$. 2, All other emissions more than 30 dB below the limit. 3, Emission Level= Read Level+ Antenna Correct Factor +Cable Loss							

Test mode: LTE BAND 17 10MHz (RB size 1 & RB offset 0) for QPSK							
Channel: Middle			Date of Test: 2022-01-11				
Frequency (MHz)	Spurious Emission					Limit (dBm)	Result
	Polarization (H&V)	Read Level (dBm)	Antenna Correct Factor (dBi)	Cable Loss (dB)	Emission Level (dBm)		
1673.00	Horizontal	-44.53	7.49	3.97	-37.12	-13.00	Pass
2509.50	H	-50.33	7.03	5.05	-48.22		
3346.00	H	-64.59	12.48	5.98	-62.33		
1673.00	Vertical	-42.42	8.02	3.97	-40.16	-13.00	Pass
2509.50	V	-57.22	10.47	5.05	-54.87		
3346.00	V	-69.43	16.92	5.98	-67.08		

Remark: 1, The testing has been conformed to $10 \times 836.5\text{MHz} = 8365\text{MHz}$.
 2, All other emissions more than 30 dB below the limit.
 3, Emission Level= Read Level+ Antenna Correct Factor +Cable Loss

-----End of Report-----