



EMC TEST REPORT

Applicant VivaChek Biotech(Hangzhou) Co., Ltd.
FCC ID 2APAPVGM08
Product Blood Glucose Meter
Model VGM08
Report No. R2111A0974-E1V1
Issue Date March 22, 2022

TA Technology (Shanghai) Co., Ltd. tested the above equipment in accordance with the requirements in **FCC Code CFR47 Part15B (2020)/ ANSI C63.4 (2014)**. The test results show that the equipment tested is capable of demonstrating compliance with the requirements as documented in this report.

Wei Liu

Prepared by: Wei Liu

Guangchang Fan

Approved by: Guangchang Fan

TA Technology (Shanghai) Co., Ltd.

No.145, Jintang Rd, Tangzhen Industry Park, Pudong Shanghai, China

TEL: +86-021-50791141/2/3

FAX: +86-021-50791141/2/3-8000



Table of Contents

1	Test Laboratory.....	5
1.1	Notes of the Test Report.....	5
1.2	Test facility.....	5
1.3	Testing Location.....	5
2	General Description of Equipment under Test.....	6
2.1	Applicant and Manufacturer Information.....	6
2.2	General information.....	6
2.3	Applied Standards.....	7
2.4	Test Mode.....	8
3	Test Case Results.....	9
3.1	Radiated Emission.....	9
3.2	Conducted Emission.....	14
4	Main Test Instruments.....	17
	ANNEX A: The EUT Appearance.....	18
	ANNEX B: Test Setup Photos.....	19



Version	Revision description	Issue Date
Rev.0	Initial issue of report.	December 22, 2021
Rev.1	Update information in Page 6.	March 22, 2022

Note: This revised report (Report No. R2111A0974-E1V1) supersedes and replaces the previously issued report (Report No. R2111A0974-E1). Please discard or destroy the previously issued report and dispose of it accordingly.

Summary of measurement results

Number	Test Case	Clause in FCC Rules	Conclusion
1	Radiated Emission	FCC Part15.109, ANSI C63.4-2014	PASS
2	Conducted Emission	FCC Part15.107, ANSI C63.4-2014	PASS
Date of Testing: November 23, 2021 ~ November 24, 2021			
Date of Sample Received: November 17, 2021			
Note: All indications of Pass/Fail in this report are opinions expressed by TA Technology (Shanghai) Co., Ltd. based on interpretations and/or observations of test results. Measurement Uncertainties were not taken into account and are published for informational purposes only.			

1 Test Laboratory

1.1 Notes of the Test Report

This report shall not be reproduced in full or partial, without the written approval of **TA technology (shanghai) co., Ltd.** The results documented in this report apply only to the tested sample, under the conditions and modes of operation as described herein. Measurement Uncertainties were not taken into account and are published for informational purposes only. This report is written to support regulatory compliance of the applicable standards stated above.

1.2 Test facility

FCC (Designation number: CN1179, Test Firm Registration Number: 446626)

TA Technology (Shanghai) Co., Ltd. has been listed on the US Federal Communications Commission list of test facilities recognized to perform measurements.

A2LA (Certificate Number: 3857.01)

TA Technology (Shanghai) Co., Ltd. has been listed by American Association for Laboratory Accreditation to perform measurement.

1.3 Testing Location

Company: TA Technology (Shanghai) Co., Ltd.
Address: No.145, Jintang Rd, Tangzhen Industry Park, Pudong Shanghai, China
City: Shanghai
Post code: 201201
Country: P. R. China
Contact: Fan Guangchang
Telephone: +86-021-50791141/2/3
Fax: +86-021-50791141/2/3-8000
Website: <http://www.ta-shanghai.com>
E-mail: fanguangchang@ta-shanghai.com

2 General Description of Equipment under Test

2.1 Applicant and Manufacturer Information

Applicant	VivaChek Biotech(Hangzhou) Co., Ltd.
Applicant address	Level 2, Block 2, 146East Chaofeng Rd., Yuhang Economy Development Zone, Hangzhou, 311100 Zhejiang P.R. China
Manufacturer	VivaChek Biotech(Hangzhou) Co., Ltd.
Manufacturer address	Level 2, Block 2, 146East Chaofeng Rd., Yuhang Economy Development Zone, Hangzhou, 311100 Zhejiang P.R. China

2.2 General information

EUT Description			
Device Type	Portable Device		
Model	VGM08		
SN	341A1000009		
HW Version	2079006401		
SW Version	SW2071640113A001		
Power Rating	DC 3.7V from battery		
Connecting I/O Port(s)	Please refer to the User's Manual.		
Antenna Type	PCB Antenna		
Frequency	Band	Tx (MHz)	Rx (MHz)
	Bluetooth LE	2400 ~ 2483.5	2400 ~ 2483.5
EUT Accessory			
Battery 1	Manufacturer: DONGGUAN XIN KE DA ENERGY CO., LTD Model: 502030 DC 3.7V, 250mAh, 0925Wh		
Auxiliary test equipment			
Adapter	Manufacturer: BYD Model: HW-090200UH0		
<p>Note: 1. The EUT is sent from the applicant to TA and the information of the EUT is declared by the applicant.</p> <p>2. The EUT don't have standard Adapter. The Adapter used for testing in this report is the after-market accessory.</p>			



2.3 Applied Standards

According to the specifications of the manufacturer, it must comply with the requirements of the following standards:

Test standards

FCC Code CFR47 Part15B (2020)

ANSI C63.4 (2014)



2.4 Test Mode

Test Mode	
Mode 1	Adapter + EUT + Receiver

3 Test Case Results

3.1 Radiated Emission

Ambient condition

Temperature	Relative humidity	Pressure
15°C~35°C	30%~60%	101.5kPa

Methods of Measurement

The EUT is placed on a non-metallic table 0.8m above the horizontal metal reference ground plane. The distance between EUT and receive antenna should be 3 meters. During the test, the EUT was operating in its typical mode. The test method is according to ANSI C63.4-2014. Sweep the whole frequency band through the range from 30MHz to the 5th harmonic of the carrier. During the test, the height of receive antenna shall be moved from 1 to 4 meters, and the antenna shall be performed under horizontal and vertical polarization. The turn table shall be rotated from 0 to 360 degrees for detecting the maximum of radiated signal level.

The data of cable loss and antenna factor has been calibrated in full testing frequency range before the testing. During the test, the EUT is worked at maximum output power.

Set the spectrum analyzer in the following:

Below 1GHz:

RBW=100 kHz / VBW=300 kHz / Sweep=AUTO

Above 1GHz:

(a) PEAK Detector: RBW=1MHz / VBW=3MHz / Sweep=AUTO

(b) AVERAGE Detector: RBW=1MHz / VBW=3MHz / Sweep=AUTO

The radiated emission was measured in the following position: EUT stand-up position (Z axis), lie-down position (X, Y axis). The worst emission was found in lie-down position (X axis) and the worst case was recorded.

During the test, EUT is connected to a laptop via a USB cable in the case of Transfer Data mode. The EUT is used as the peripheral equipment of the PC. The data is transferred from EUT to PC; PC is connected to server via a long LAN cable.

Test Setup

Below 1GHz

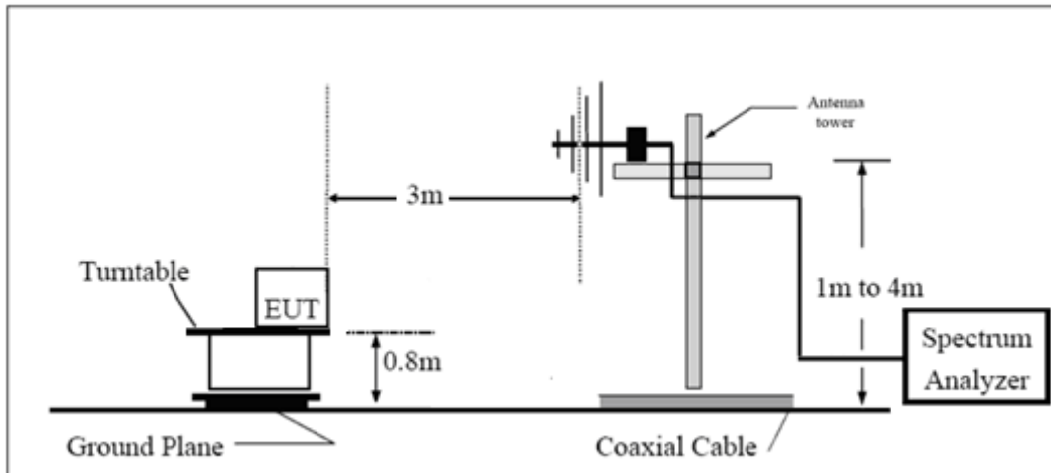

Above 1GHz

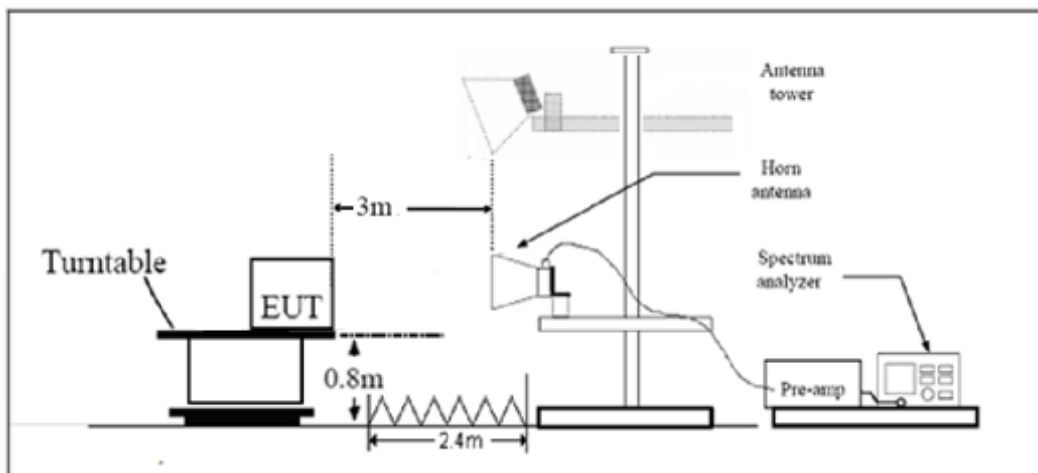

Note: Area side: 2.4mX3.6m

Antenna Tower meets ANSI C63.4 requirements for measurements above 1 GHz by keeping the antenna aimed at the EUT during the antenna's ascent/ descent along the antenna mast.

Limits**Class B**

Frequency (MHz)	Field Strength (dB μ V/m)	Detector
30 -88	40.0	Quasi-peak
88-216	43.5	Quasi-peak
216 – 960	46.0	Quasi-peak
960-1000	54.0	Quasi-peak
1000-5 th harmonic of the highest frequency or 40GHz, which is lower	54 74	Average Peak

Measurement Uncertainty

The assessed measurement uncertainty to ensure 95% confidence level for the normal distribution is with the coverage factor $k = 1.96$.

Frequency	Uncertainty
30MHz~200MHz	4.17 dB
200MHz~1000MHz	4.84 dB
1GHz~18GHz	4.35 dB

Test Results

Sweep the whole frequency band through the range from 30MHz to the 5th harmonic of the carrier,

The following graphs display the maximum values of horizontal and vertical by software.

For above 1GHz, Blue trace uses the peak detection, Green trace uses the average detection.

A font (Level in dB μ V/)in the test plot =(level in dB μ V/m)

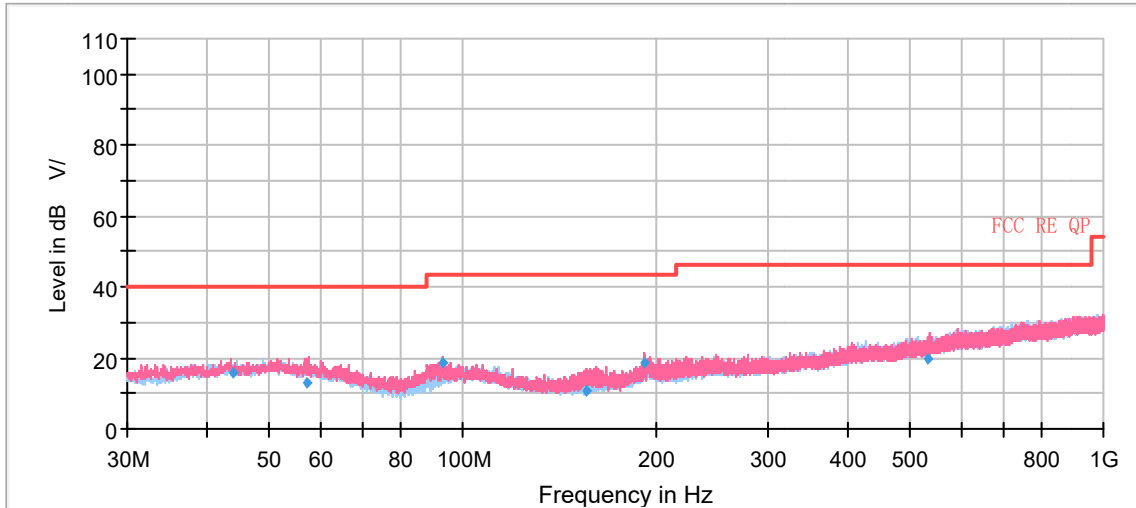

Radiated Emission from 30MHz to 1GHz

Frequency (MHz)	Quasi-Peak (dBuV/m)	Limit (dBuV/m)	Margin (dB)	Meas. Time (ms)	Height (cm)	Polarization	Azimuth (deg)	Correct Factor (dB)
43.930667	15.60	40.00	24.40	1000.0	110.0	V	258.0	20
57.020333	12.91	40.00	27.09	1000.0	175.0	V	53.0	20
93.413333	18.60	43.50	24.90	1000.0	109.0	V	138.0	17
156.014000	10.64	43.50	32.86	1000.0	100.0	V	328.0	15
192.037667	18.44	43.50	25.06	1000.0	100.0	V	307.0	18
533.581333	19.72	46.00	26.28	1000.0	125.0	V	318.0	25

Remark: 1. Correction Factor = Antenna factor + Insertion loss(cable loss+amplifier gain)

2. Margin = Limit – Quasi-Peak

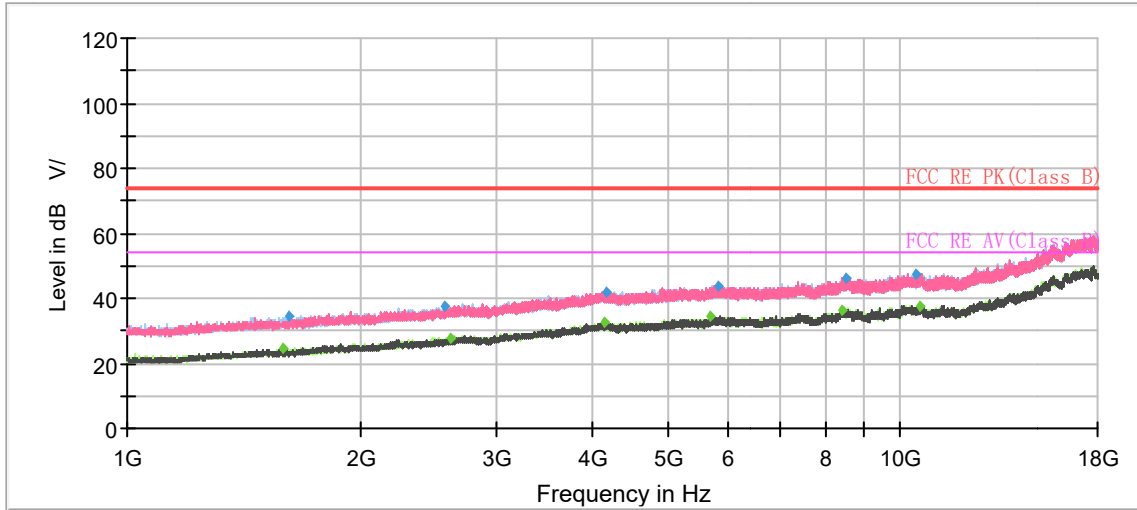

Radiated Emission from 1GHz to 18GHz

Frequency (MHz)	Peak (dBuV/m)	Average (dBuV/m)	Limit (dBuV/m)	Margin (dB)	Meas. Time (ms)	Height (cm)	Polarization	Azimuth (deg)	Correct Factor (dB)
1587.066667	---	24.62	54.00	29.38	500.0	200.0	H	115.0	-15
1618.800000	34.34	---	74.00	39.66	500.0	100.0	H	78.0	-15
2573.633333	37.74	---	74.00	36.26	500.0	200.0	V	248.0	-10
2616.133333	---	27.71	54.00	26.29	500.0	200.0	H	21.0	-10
4137.066667	---	32.55	54.00	21.45	500.0	100.0	H	257.0	-3
4162.566667	42.06	---	74.00	31.94	500.0	100.0	V	34.0	-3
5693.133333	---	34.23	54.00	19.77	500.0	200.0	V	7.0	0
5818.933333	43.86	---	74.00	30.14	500.0	200.0	V	111.0	0
8399.533333	---	36.26	54.00	17.74	500.0	200.0	V	11.0	3
8519.100000	46.02	---	74.00	27.98	500.0	200.0	V	0.0	4
10480.900000	47.34	---	74.00	26.66	500.0	200.0	V	185.0	6
10615.200000	---	37.79	54.00	16.21	500.0	100.0	V	100.0	5

3.2 Conducted Emission

Ambient condition

Temperature	Relative humidity	Pressure
15°C~35°C	30%~60%	101.5kPa

Methods of Measurement

The EUT is placed on a non-metallic table of 80cm height above the horizontal metal reference ground plane. During the test, the EUT was operating in its typical mode. The test method is according to ANSI C63.4-2014. Connect the AC power line of the EUT to the L.I.S.N. Use EMI receiver to detect the average and Quasi-peak value. RBW is set to 9 kHz, VBW is set to 30kHz. The measurement result should include both L line and N line.

Test Setup

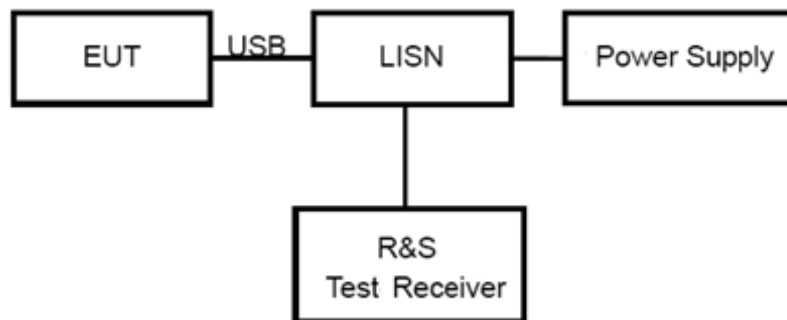

Note: Power Supply is AC Power source and it is used to change the voltage 120V/60Hz.

Limits

Frequency (MHz)	Conducted Limits(dBμV)	
	Quasi-peak	Average
0.15 - 0.5	66 to 56 *	56 to 46 *
0.5 - 5	56	46
5 - 30	60	50

*: Decreases with the logarithm of the frequency.

Measurement Uncertainty

The assessed measurement uncertainty to ensure 95% confidence level for the normal distribution is with the coverage factor $k = 1.96$. $U = 2.57$ dB.

Test Results

Following plots, Blue trace uses the peak detection; Green trace uses the average detection.

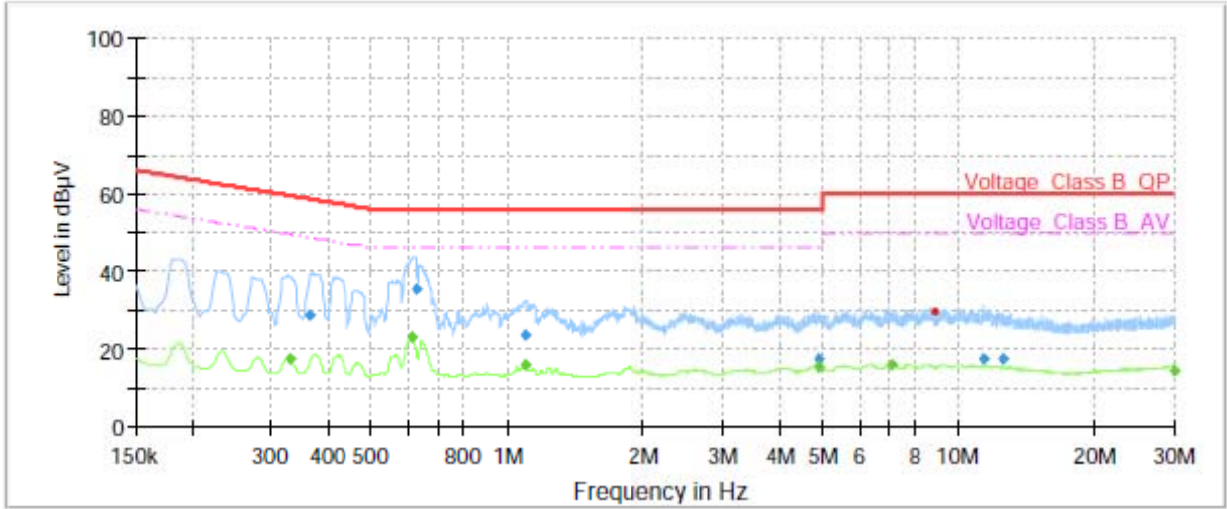

Frequency (MHz)	QuasiPeak (dBµV)	Average (dBµV)	Limit (dBµV)	Margin (dB)	Meas. Time (ms)	Bandwidth (kHz)	Line	Filter	Corr. (dB)
0.33	---	17.47	49.51	32.04	70.0	9.000	L1	ON	21
0.36	28.63	---	58.69	30.06	70.0	9.000	L1	ON	21
0.62	---	23.10	46.00	22.90	70.0	9.000	L1	ON	20
0.62	35.45	---	56.00	20.55	70.0	9.000	L1	ON	20
1.09	23.47	---	56.00	32.53	70.0	9.000	L1	ON	20
1.10	---	15.93	46.00	30.07	70.0	9.000	L1	ON	20
4.88	---	15.42	46.00	30.58	70.0	9.000	L1	ON	19
4.89	17.50	---	56.00	38.50	70.0	9.000	L1	ON	19
7.09	---	15.98	50.00	34.02	70.0	9.000	L1	ON	20
11.31	17.63	---	60.00	42.37	70.0	9.000	L1	ON	20
12.48	17.29	---	60.00	42.71	70.0	9.000	L1	ON	20
30.00	---	14.58	50.00	35.42	70.0	9.000	L1	ON	20

Remark: Correct factor=cable loss + LISN factor

L line

Conducted Emission from 150 KHz to 30 MHz

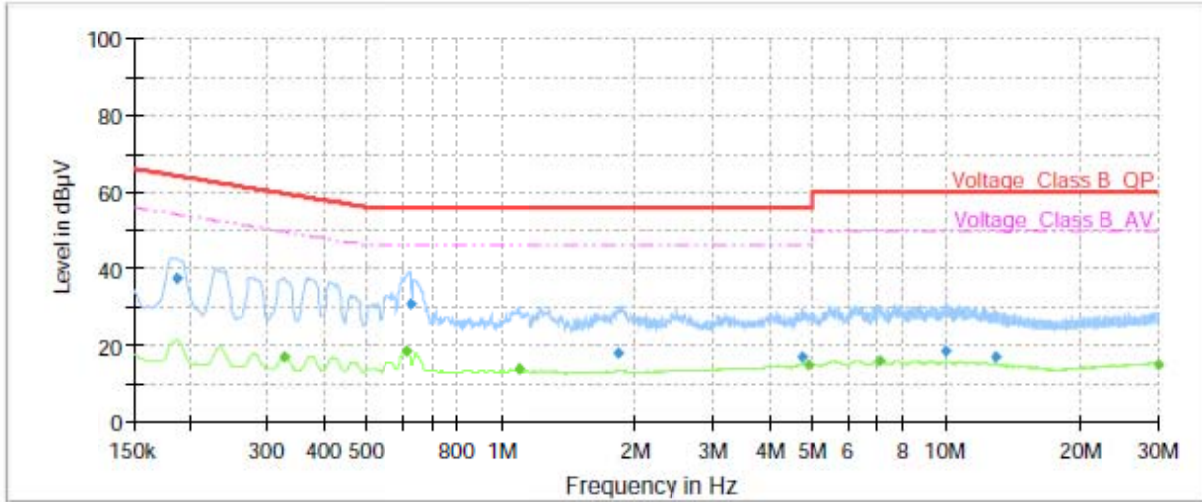

Frequency (MHz)	QuasiPeak (dBµV)	Average (dBµV)	Limit (dBµV)	Margin (dB)	Meas. Time (ms)	Bandwidth (kHz)	Line	Filter	Corr. (dB)
0.19	37.68	---	64.21	26.53	70.0	9.000	N	ON	21
0.33	---	17.06	49.57	32.51	70.0	9.000	N	ON	21
0.62	---	18.68	46.00	27.32	70.0	9.000	N	ON	20
0.62	30.70	---	56.00	25.30	70.0	9.000	N	ON	20
1.09	---	13.73	46.00	32.27	70.0	9.000	N	ON	20
1.84	17.94	---	56.00	38.06	70.0	9.000	N	ON	20
4.76	17.01	---	56.00	38.99	70.0	9.000	N	ON	19
4.88	---	15.03	46.00	30.97	70.0	9.000	N	ON	19
7.07	---	15.91	50.00	34.09	70.0	9.000	N	ON	20
9.97	18.56	---	60.00	41.44	70.0	9.000	N	ON	20
12.96	17.01	---	60.00	42.99	70.0	9.000	N	ON	20
30.00	---	14.64	50.00	35.36	70.0	9.000	N	ON	20

Remark: Correct factor=cable loss + LISN factor

N line

Conducted Emission from 150 KHz to 30 MHz

4 Main Test Instruments

Name	Manufacturer	Type	Serial Number	Calibration Date	Expiration Time
Spectrum Analyzer	R&S	FSV40	100815	2020-12-13	2021-12-12
EMI Test Receiver	R&S	ESCI7	100936	2020-12-13	2021-12-13
Trilog Antenna	SCHWARZBECK	VULB 9163	1023	2020-05-05	2023-05-04
Horn Antenna	R&S	HF907	102723	2020-08-11	2023-08-10
EMI Test Receiver	R&S	ESR	101667	2021-05-16	2022-05-15
LISN	R&S	ENV216	101171	2018-12-15	2021-12-14
Test software	EMC32	R&S	9.26.01	/	/
Test software	EMC32	R&S	10.35.10	/	/

*****END OF REPORT *****



ANNEX A: The EUT Appearance

The EUT Appearance are submitted separately.



ANNEX B: Test Setup Photos

The Test Setup Photos are submitted separately.