

MULTIPLEX[®] Technical Documentation

Project name: Trinity

Module No.: 1-00391 WSRX M-Link 2.4GHz

Installation Information

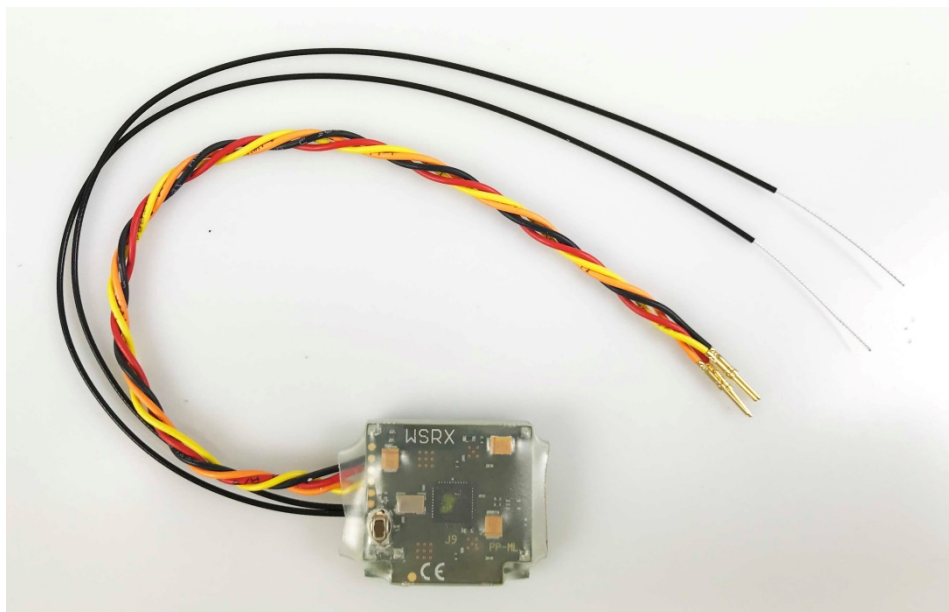

The modular transceiver WSRX 2.4GHz is only approved for use by the grantee in its own products and not intended for sale to third parties.

WSRX 2.4GHz meets the integration instructions regarding FCC 15.212

The whole Trinity assembly instructions are described in the TRINITY installation manual.

Contained FCC ID: 2APABWSRX

Overview

TRINITY Communication Link

The communication with the UAV *Trinity* is ensured by two links:

1. QBase, a 915MHz flight data link. A downlink sends telemetry data from the *Trinity* to QBase ground control and an uplink sends commands to the *Trinity* Qbase air control.
2. The second link is a 2.4 GHz RC link between the RC-radio Cockpit SX and the *Trinity*. It is used as an uplink for control commands and as a downlink sending telemetry data from the *Trinity* to the RC-radio.

It is possible to continue the mission even though one link is lost. In case of a loss of both links the Trinity flies to the link reestablishing waypoint and tries to reestablish the connection. If both connections cannot be reestablished the Trinity will land automatically after the loiter time that was set in QBase expired. The automatic landing might damage the *Trinity*.

The 2.4GHz M-Link RC control System consists of the following parts:

WSRX module (Air Modem)

2.4GHz transceiver module for the integration in the UAV *Trinity*.

Cockpit SX Trinity

2.4GHz RC-radio for remote control of models

Technical Data WSRX module:

Operation frequency:	2400 - 2483.5MHz
Modulation / channels:	GFSK / 39 (AFHSS)
Output Power:	<20dBm EIRP
Antenna:	external wire antenna

FCC Warning Statements

This device complies with part 15 of the FCC rules. Operation is subject to the following two conditions:

(1) This device may not cause harmful interference, and (2) this device must accept any interference received, including interference that may cause undesired operation.

Note: This equipment has been tested and found to comply with the limits for a Class B digital device, pursuant to part 15 of the FCC Rules. These limits are designed to provide reasonable protection against harmful interference in a residential installation. This equipment generates, uses and can radiate radio frequency energy and, if not installed and used in accordance with the instructions, may cause harmful interference to radio communications. However, there is no guarantee that interference will not occur in a particular installation. If this equipment does cause harmful interference to radio or television reception, which can be determined by turning the equipment off and on, the user is encouraged to try to correct the interference by one or more of the following measures:

--Reorient or relocate the receiving antenna.

--Increase the separation between the equipment and receiver.

--Connect the equipment into an outlet on a circuit different from that to which the receiver is connected.

--Consult the dealer or an experienced radio/TV technician for help.

Block Diagram WSRX M-Link 2.4GHz for UAV Trinity

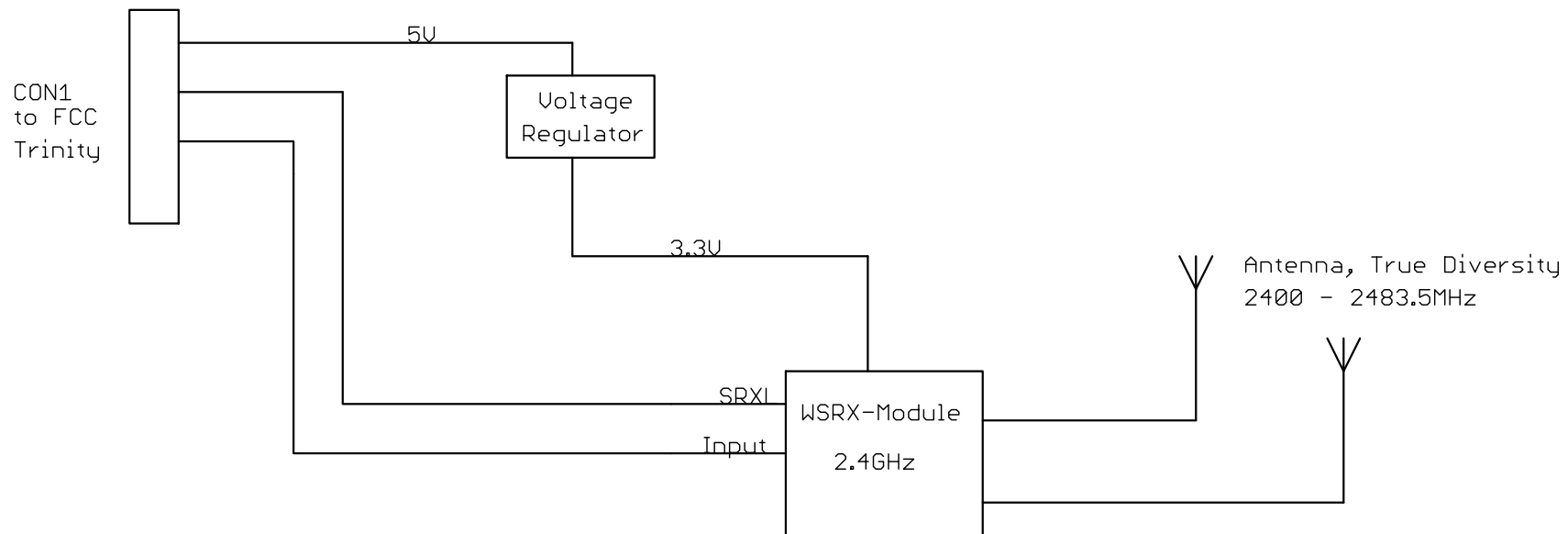

SRXL: Serial RC-Channel Output

Input: Telemetry Data

MULTIPLEX[®]		Westliche Gewerbestr. 1 75015 Bretten-Gölshausen Tel.: 07252 580930	
Projekt: TRINITY RC-DATALINK 2.4GHz			
Baugruppe:		Entwickler:	
Datum: 13.08.2020 10:14		Datei: Blockdiagramm WSRX Trinity	

MULTIPLEX[®] Technical Documentation

Antenna description

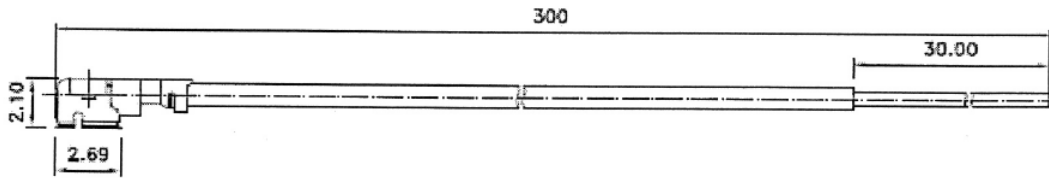

The RF-module WSRX is a true diversity transceiver.

The maximum output power is 20dBm EIRP.

Its two lambda/4 internal wire antennas are fixed to the PCB board with a unique connector.

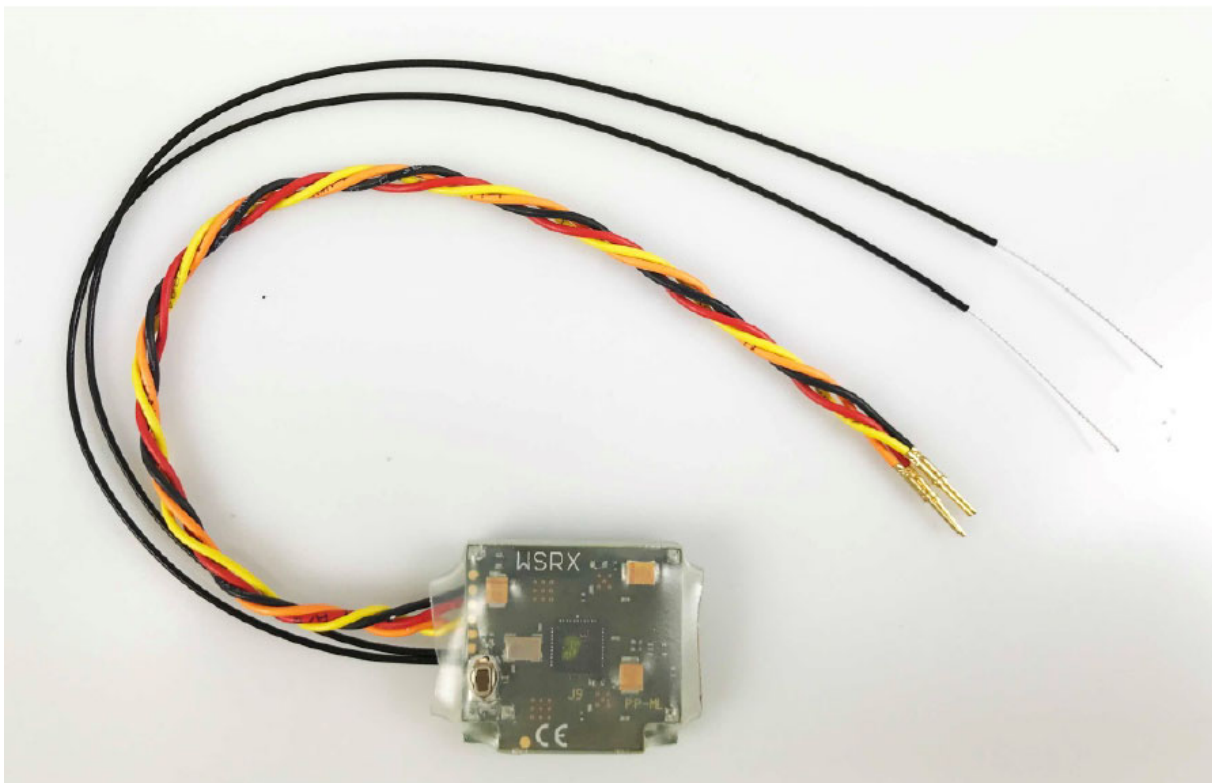

Mounting the module refer to page 7+8 in this document.

Excerpt from Trinity Assembly Specification V2

MULTIPLEX

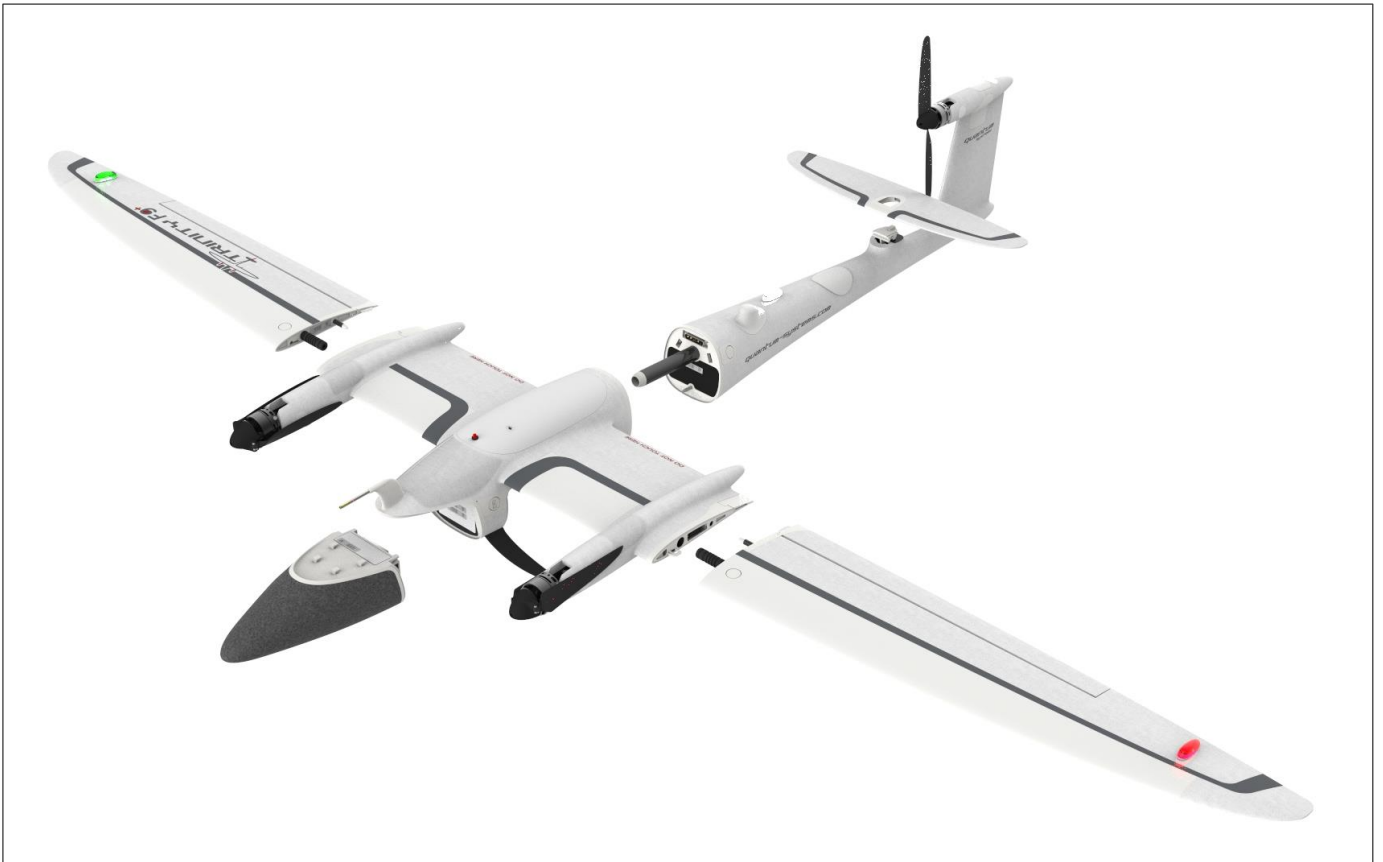

1-01256 TRINITY F9+ Assembly Specification V2

Part A – Part lists and definitions

Release date: 2019-08-20

1 General references

- This document may not be handed on to any third party without the explicit clearance from MULTIPLEX.
- This specification is written and designated for skilled users with substantial technical capabilities.
- Indications of horizontal, vertical or longitudinal position are always meant in the direction of flight at normal attitude.
- Item descriptions in the text are written in ***bold italic letters***.
- The pictures do not necessarily show the latest version of parts and tools. This does not affect the technical principal of the assembling procedure.
- All D-Sub-connectors of the harnesses are installed with the wide side of the connector on top, the narrow side on the bottom.
- Persons assembling the Trinity have to wear antistatic shoes.
- All finished Trinity Parts need at least 24h for evaporation. Do not store the finished parts in the transport cases before, to avoid deposition of CA fumes on surfaces.
- Consumables (e.g. CA glue, LOCTITE) may not be used after expiration date.

Excerpt from Trinity Assembly Specification V2

9.2.4 Installing Receiver and Magnetometer

Part #	Item number	Description German	Description English	Quantity
1	1-00391	Platine Empfänger Telemetrie_Trinity	Receiver Telemetry Board	1
2	1-01157	Magnetometer	Magnetometer	1

1. Install the **Receiver Telemetry Board** (#1) at the innermost position of the designated cavity with hot melt adhesive (see red arrow).
2. Lay the antennas in the slot and the **Antenna Tube 60mm**. Fasten the antennas with small parts of thin adhesive tape or hot melt adhesive where necessary to keep them in place.

pic 10

3. Install the **Magnetometer** (#2) in the designated cavity with hot melt adhesive.

pic 20

Excerpt from Trinity Assembly Specification V2

9.2.4 Installing Receiver and Magnetometer

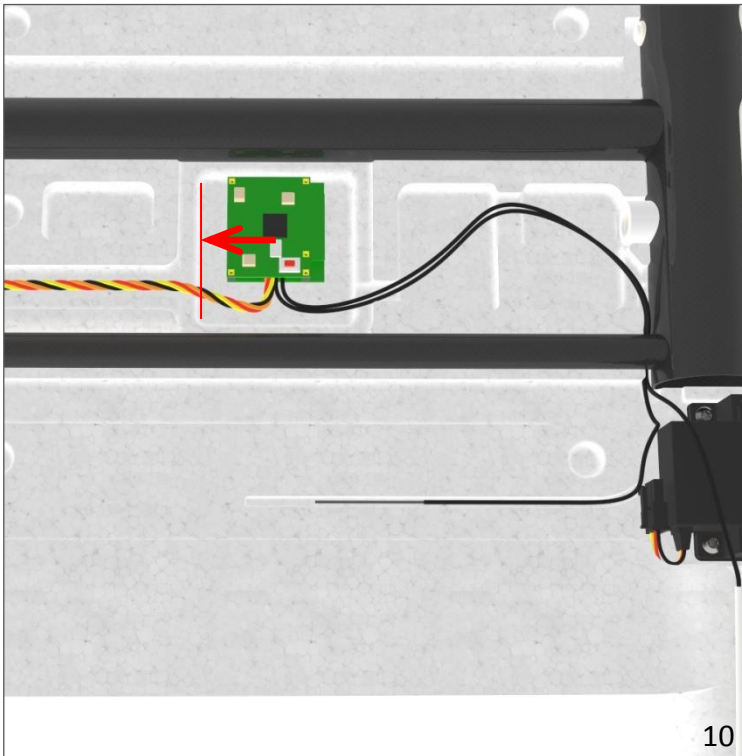

the two Antenna wires are mounted inside the wing in a 90° angle

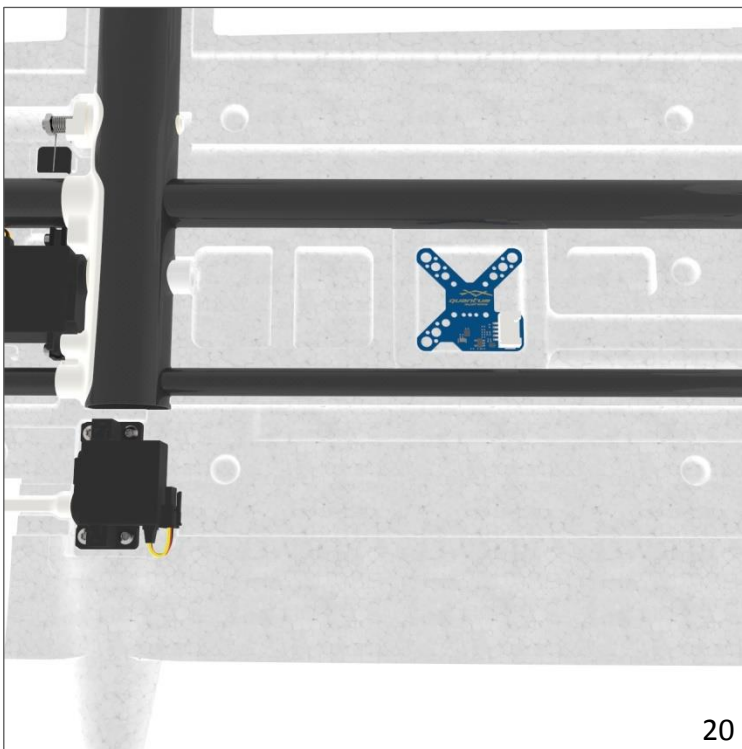

Excerpt from Trinity Assembly Specification V2