



X150

150M WIRELESS VIDEO TRANSMISSION SYSTEM
INSTRUCTION MANUAL



Table of Contents

About the 150M Wireless Video Transmission System	1
Features	1
Receiver Diagram	2
Transmitter Diagram	3
Installation	4-6
Frequency Selection	7
Troubleshooting Guide	8
Warning	9
Specification	10
FCC Statement	11

Features

- . Uses 5GHz ISM frequency band, maximum 10 frequency channels selection, coexist with WIFI.
- . Highest resolution supports color depth of up to 30 bits(10 bits/color),
- . HDMI and SD/HD/3G SDI input and output, HDMI & SDI cross conversion is supported.
- . Support wireless HD video(up to 1080P 60Hz) with no compression and no delay up to 300m(984ft).
- . Support point to point, and point to multi points network topology,
- . Support professional audio formats include Dolby True HD, DTS-master, etc.
- . AES-128 encryption with air interface HD video data stream.
- . 7-36V Wide range power voltage input, compatible with most kinds of camera batteries.
- . Sony F970 battery buckle, convenient for field battery install and replacement.
- . All input and output ports have +-8 kV ESD protection level(HBM, contact discharge).
- . Plug & Play – no software is required.
- . Professional standard 4-pin LEMO power plugs.
- . Each RX(receiver) paired to the unique TX(transmitter) in factory.
- . Industrial metal and plastic case stable and reliable.
- . RX built-in antenna.
- . Signal indicators for wireless power status, Video status and receiver RSSI.
- . The hard carrying cases provide water and shock proof to product.

Receiver Diagram

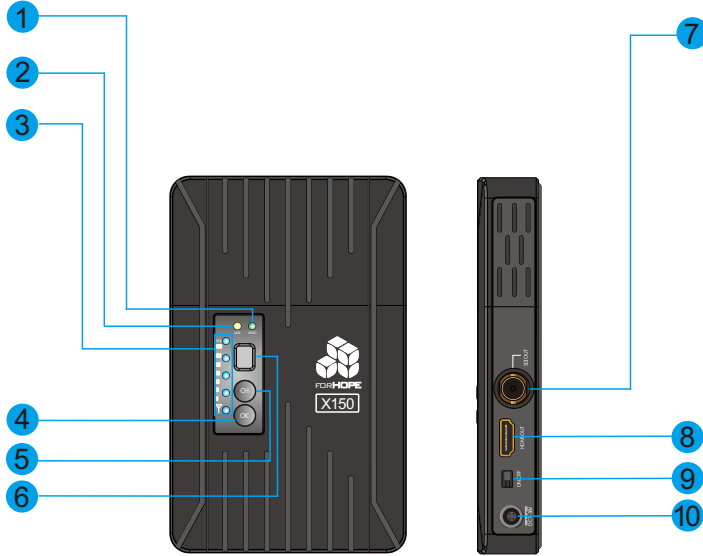

Receiver :

- | | |
|--------------------------------|-----------------------|
| 1 : Video input indicator | 6 : Frequency display |
| 2 : Link status indicator | 7 : SDI output |
| 3 : RSSI | 8 : HDMI output |
| 4 : Frequency confirm button | 9 : Power on/off |
| 5 : Frequency selection button | 10 : DC input |

Transmitter Diagram

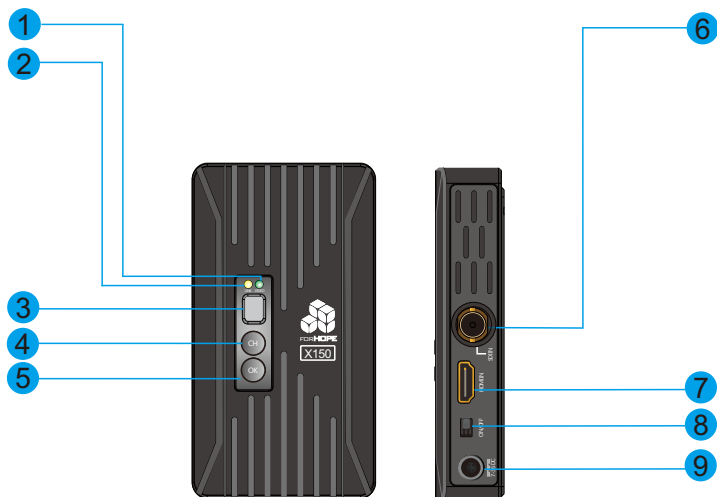

Transmitter :

- | | |
|--------------------------------|------------------|
| 1 : Video input indicator | 6 : SDI input |
| 2 : Link status indicator | 7 : HDMI input |
| 3 : Frequency display | 8 : Power on/off |
| 4 : Frequency selection button | 9 : DC input |
| 5 : Frequency confirm button | |

Installation

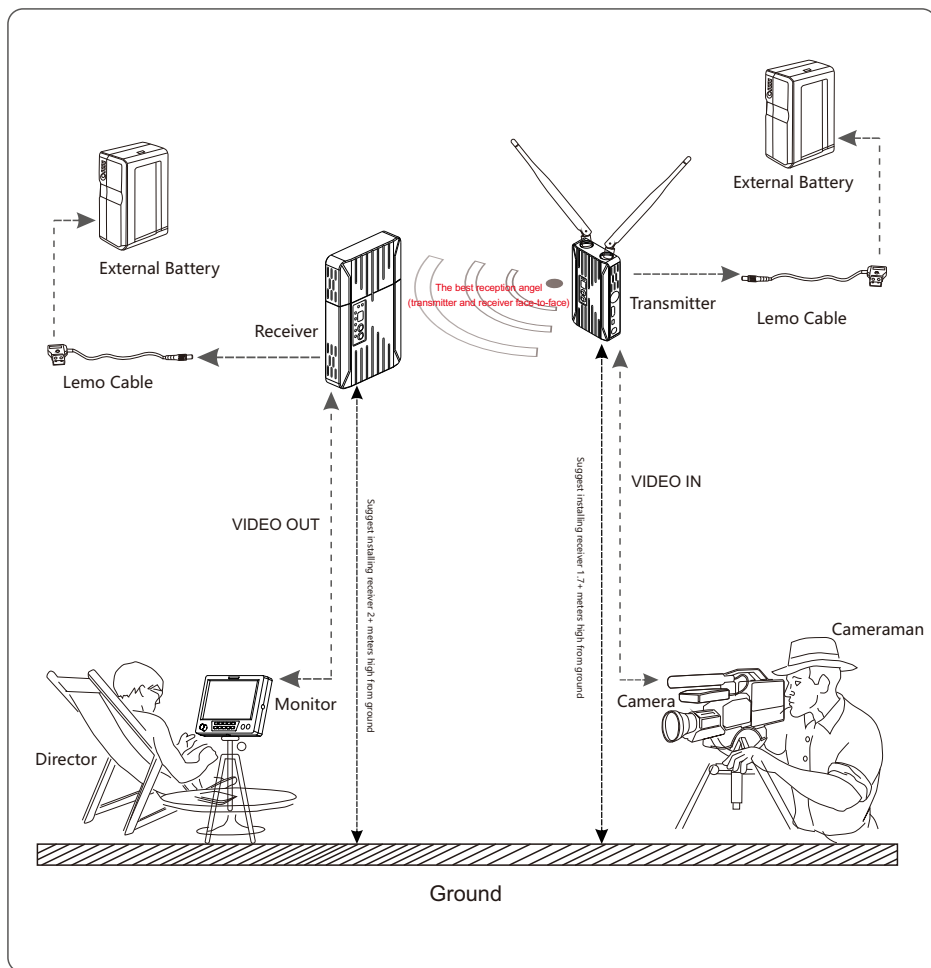

Installation

- 1) Ensure the video source output of the camera is OK, and the HD monitor is powered on and switched to connected video input port.
- 2) Ensure 2 TX antennas are installed. For optimal results set the dual antennas in the form of a “V” and maintain unobstructed line of sight between transmitter and receiver. Below figure for your reference.



- 3) Ensure all input, output SDI or HDMI cables are connected.
- 4) Ensure both transmitter and receiver are powered via battery or DC input. Then turn on power switch of the transmitter and receiver respectively. The POWER indicator will then light.
- 5) Ensure the transmitter and receiver is set with the same frequency.
- 6) If the camera is on and video input is OK, TX side VIDEO indicator will light.

Installation

7) Before RX finished wireless link with TX, 5 RSSI indicators and VIDEO indicators are off; when wireless link is done, RSSI indicators will light first and indicate the signal strength. If the receiver detects wireless video normal internally from air interface, VIDEO indicator will light. Before that, If SDI or HDMI video out port of the receiver has HD monitor connected, it will display an OSD of Link connecting..... as in the figure below.

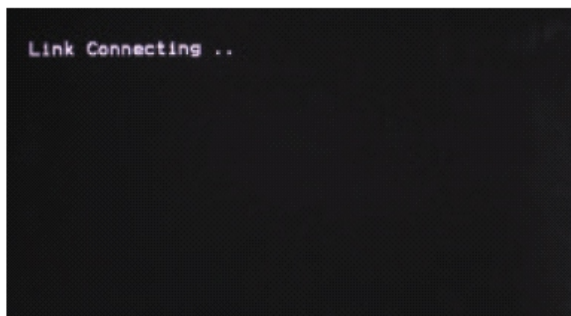

8) The system will spend 20-30 seconds constructing the link, depending on link strength and the signal channel condition. When wireless link is established the RSSI light will illuminate, indicating the current wireless signal strength, VIDEO indicators will light, and the connected HD monitor will be playing the real-time video and audio.

Frequency Selection

The wireless transmission system works in the 5.1-5.9GHz frequency band and can be flexibly configured to other licensed or ISM bands to accommodate different global regions. The front panel of the transmitter features a frequency selection button (see below illustration), which provides a maximum of 4 workable frequency channels, and supports a maximum of 4 simultaneous receiver units.

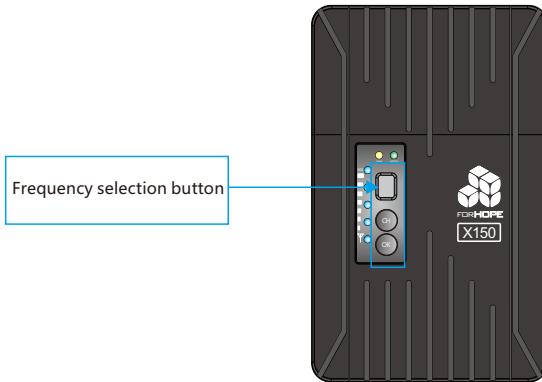

Troubleshooting Guide

	Step 1	Step 2	Step 3	Step 4
The system can't establish link	If the transmission system can't establish link at long distance but works well at shorter distance. Please check if the transmitter and receiver under specified working distance. And if the transmitter and receiver set at the same frequency.	2 If the problem is not solved after step 1. Please restart the transmitter and receiver.	3 If the problem is not solved after step 2. Please shorten distance and check the link status.	4 If established link at shorter distance. Please go to next guide.
The working distance can't reach 150M	If established link at shorter distance. Please check if the antennas are screwed tightly. The transmitter and receiver are NOT parallel to each other. The 2 TX antennas' angle is 45°. Make sure no big obstacle between transmitter and receiver.	3 If the problem is not solved after step 1. Please change the frequency and check the link status. If the link is improved. The problem is caused by interference.	4 If the problem is not solved after step 2. Please replace the antennas with new ones and try again.	4 If the problem is not solved after step 3. Please contact with us for RMA.
The video quality is bad	Please make sure the distance is within the maximum working distance. The transmitter and receiver are NOT parallel to each other. The 2 TX antennas' angle is 45°. If there is big obstacle between transmitter and receiver, please shorten distance.	3 If the RSSI on receiver has more than 3 lights on, please go to next step. If the RSSI has less than 3 lights on. Please change the frequency and check the video quality.	3 If the video quality is not improved after changing frequency. Please replace antennas with new ones or try other system with good performance before.	4 If the other system has the same problem. Please move to other place and try again. If the old system works well and the new system still has problem after changing place. Please contact with us for RMA.
The RSSI is good but the video quality is bad	The RSSI is good but the video quality is bad. Please make sure the distance is within the maximum working distance and the 2 TX antennas' angle is 45°, the transmitter and receiver are NOT parallel to each other.	3 If the problem is not solved after step 1. Please check the input video resolution. Downgrade the resolution and check again. 1080i's working distance is longer than 1080p with the same video quality.	3 If the video quality is not improved after downgrading resolution. Please shorten distance by half. If the video quality is improved. Please record the distance when the video quality becoming bad.	4 If the video quality is not improved after shortening distance. Please change the frequency. If it's still not improved. Please contact with us for RMA.

Warning

- Do not expose this device to extreme hot, cold, dusty or humid environments.
- Do not scratch the device with sharp objects.
- Do not drop this device from high place, as this may cause hardware damage.
- This device is designed for non-waterproofing. Please do not allow any liquid to penetrate into the device.
- Do not attempt to dismantle, open or repair this device yourself, as this may cause permanent damage to the device.。

Specification

	Transmitter	Receiver
Interface	SDI Input(BNC female); HDMI Input(Type A female); 2 Antenna port(RP-SMA male); DC input(4pin LEMO female)	SDI Output(BNC female); HDMI Output(Type A female); DC input(4pin LEMO female)
Supply Voltage Range	7-36V DC	7-36V DC
Transmission Range	up to 300 meters/984 ft	up to 300 meters/984 ft
Power Consumption	<6.5W	<6W
Size	(L x W x H): 67*122.2*25.3mm	(L x W x H): 95.4*152.2*26mm
Input Video Format	SDI:3G, HD, and SD-SDI(Auto-Selected); HDMI: 525i, 625i, 720p 50/59.94/60, 1080i 50/59.94/60, 1080p23.98/24/25/29.9/ 30/50/59.94/60;	/
Output Video Format	/	SDI:3G, HD, and SD-SDI(Auto-Selected); HDM: 525i, 625i, 720p 50/59.94/60, 1080i 50/59.94/60, 1080p23.98/24/25 /29.9/30/50/59.94/60;
Video Processing Color Depth	Link-Yellow; VIDEO-Green	RSSI-Blue(5 LEDs); Link-Yellow; VIDEO-Green
Frequency Band	5.1-5.9GHz,configurable with China, North America, Europe, etc	5.1-5.9GHz,configurable with China, North America, Europe, etc
Modulation Mode	OFDM 16QAM	OFDM 16QAM
Transmission Power	Maximum 15dBm	/
Receiver Sensitivity	/	-75dBm
Occupied Bandwidth	20/40MHz	20/40MHz
Temperature Range	0-40°C(working temperature); -20-60°C(storage temperature)	0-40°C(working temperature); -20-60°C(storage temperature)

FCC Statement

Changes or modifications not expressly approved by the party responsible for compliance could void the user's authority to operate the equipment.

This equipment has been tested and found to comply with the limits for a Class B digital device, pursuant to Part 15 of the FCC Rules. These limits are designed to provide reasonable protection against harmful interference in a residential installation. This equipment generates uses and can radiate radio frequency energy and, if not installed and used in accordance with the instructions, may cause harmful interference to radio communications. However, there is no guarantee that interference will not occur in a particular installation. If this equipment does cause harmful interference to radio or television reception, which can be determined by turning the equipment off and on, the user is encouraged to try to correct the interference by one or more of the following measures:

- Reorient or relocate the receiving antenna.
- Increase the separation between the equipment and receiver.
- Connect the equipment into an outlet on a circuit different from that to which the receiver is connected.
- Consult the dealer or an experienced radio/TV technician for help This device complies with part 15 of the FCC rules. Operation is subject to the following two conditions (1) this device may not cause harmful interference, and (2) this device must accept any interference received, including interference that may cause undesired operation.

This equipment complies with FCC radiation exposure limits set forth for an uncontrolled environment. This equipment should be installed and operated with minimum distance 20cm between the radiator & your body

IC Statement

This device complies with Industry Canada's licence-exempt RSSs. Operation is subject to the following two conditions:

- (1) This device may not cause interference; and
- (2) This device must accept any interference, including interference that may cause undesired operation of the device.

The term "IC: " before the certification/registration number only signifies that the Industry Canada technical specifications were met. This product meets the applicable Industry Canada technical specifications.

Le présent appareil est conforme aux CNR d'Industrie Canada applicable aux appareils radio exempts de licence. L'exploitation est autorisée aux deux conditions suivantes : (1) l'appareil ne doit pas produire de brouillage, et (2) l'utilisateur de l'appareil doit accepter tout brouillage radioélectrique subi, même si le brouillage est susceptible d'en compromettre le fonctionnement