



Prüfbericht-Nr.: <i>Test report no.:</i>	CN22IMYY 001	Auftrags-Nr.: <i>Order no.:</i>	168373731	Seite 1 von 21 <i>Page 1 of 21</i>
Kunden-Referenz-Nr.: <i>Client reference no.:</i>	N/A	Auftragsdatum: <i>Order date:</i>	2022-05-23	
Auftraggeber: <i>Client:</i>	Beijing Smartmi Electronic Technology Co., Ltd. Room 6111, 1st Floor, Building 6, No.18 Xueqing Road, Haidian District, Beijing, China			
Prüfgegenstand: <i>Test item:</i>	Smartmi Robot Vacuum Cleaner			
Bezeichnung / Typ-Nr.: <i>Identification / Type no.:</i>	ZNXDJQR01ZM (Trademark: Smartmi)			
Auftrags-Inhalt: <i>Order content:</i>	Test Report			
Prüfgrundlage: <i>Test specification:</i>	CFR47 FCC Part 15: Subpart C Section 15.247 RSS-247 Issue 2 February 2017 CFR47 FCC Part 15: Subpart C Section 15.207 RSS-Gen Issue 5 March 2019 CFR47 FCC Part 15: Subpart C Section 15.209			
Wareneingangsdatum: <i>Date of sample receipt:</i>	2022-05-31	Please refer to Photo Document		
Prüfmuster-Nr.: <i>Test sample no.:</i>	A003270063-001~002 A003270481-001			
Prüfzeitraum: <i>Testing period:</i>	2022-06-06 – 2022-06-24			
Ort der Prüfung: <i>Place of testing:</i>	TÜV Rheinland (Shenzhen) Co., Ltd.			
Prüflaboratorium: <i>Testing laboratory:</i>	TÜV Rheinland (Shenzhen) Co., Ltd.			
Prüfergebnis*: <i>Test result*:</i>	Pass			
geprüft von: <i>tested by:</i>		genehmigt von: <i>authorized by:</i>		
Datum: <i>Date:</i>	2022-07-07	Ausstellungsdatum: <i>Issue date:</i>	2022-07-07	
	<small>Signed by: Chris Chen</small>		<small>Signed by: Lin Lin</small>	
Stellung / Position:	Section Manager	Stellung / Position:	Reviewer	
Sonstiges / Other:	FCC ID: 2AP98-ZNXDJQR01ZM IC: 26864-ZNXDJQR01ZM HVIN: ZNXDJQR01ZM			
Zustand des Prüfgegenstandes bei Anlieferung: <i>Condition of the test item at delivery:</i>	Prüfmuster vollständig und unbeschädigt <i>Test item complete and undamaged</i>			
* Legende:	1 = sehr gut P(ass) = entspricht o.g. Prüfgrundlage(n)	2 = gut F(ail) = entspricht nicht o.g. Prüfgrundlage(n)	3 = befriedigend N/A = nicht anwendbar	4 = ausreichend N/T = nicht getestet
* Legend:	1 = very good P(ass) = passed a.m. test specification(s)	2 = good F(ail) = failed a.m. test specification(s)	3 = satisfactory N/A = not applicable	4 = sufficient N/T = not tested
Dieser Prüfbericht bezieht sich nur auf das o.g. Prüfmuster und darf ohne Genehmigung der Prüfstelle nicht auszugsweise vervielfältigt werden. Dieser Bericht berechtigt nicht zur Verwendung eines Prüfzeichens. <i>This test report only relates to the a. m. test sample. Without permission of the test center this test report is not permitted to be duplicated in extracts. This test report does not entitle to carry any test mark.</i>				

v05

Test Summary

5.1.1 ANTENNA REQUIREMENT

RESULT: Pass

5.1.2 MAXIMUM PEAK CONDUCTED OUTPUT POWER

RESULT: Pass

5.1.3 CONDUCTED POWER SPECTRAL DENSITY

RESULT: Pass

5.1.4 99%dB BANDWIDTH

RESULT: Pass

5.1.5 6dB BANDWIDTH

RESULT: Pass

5.1.6 CONDUCTED SPURIOUS EMISSIONS MEASURED IN 100 KHz BANDWIDTH

RESULT: Pass

5.1.7 RADIATED SPURIOUS EMISSION

RESULT: Pass

5.1.8 CONDUCTED EMISSION ON AC MAINS

RESULT: Pass

Contents

1	GENERAL REMARKS.....	4
1.1	COMPLEMENTARY MATERIALS	4
2	TEST SITES	5
2.1	TEST FACILITIES.....	5
2.2	LIST OF TEST AND MEASUREMENT INSTRUMENTS	5
2.3	TRACEABILITY	6
2.4	CALIBRATION.....	6
2.5	MEASUREMENT UNCERTAINTY	6
2.6	LOCATION OF ORIGINAL DATA	7
2.7	STATUS OF FACILITY USED FOR TESTING	7
3	GENERAL PRODUCT INFORMATION.....	8
3.1	PRODUCT FUNCTION AND INTENDED USE.....	8
3.2	RATINGS AND SYSTEM DETAILS	8
3.3	INDEPENDENT OPERATION MODES.....	9
3.4	NOISE GENERATING AND NOISE SUPPRESSING PARTS.....	9
3.5	SUBMITTED DOCUMENTS	9
4	TEST SET-UP AND OPERATION MODES.....	10
4.1	PRINCIPLE OF CONFIGURATION SELECTION.....	10
4.2	TEST OPERATION AND TEST SOFTWARE.....	10
4.3	SPECIAL ACCESSORIES AND AUXILIARY EQUIPMENT.....	10
4.4	COUNTERMEASURES TO ACHIEVE EMC COMPLIANCE	10
4.5	TEST SETUP DIAGRAM	11
5	TEST RESULTS.....	13
5.1	TRANSMITTER REQUIREMENT & TEST SUITES.....	13
5.1.1	<i>Antenna Requirement.....</i>	13
5.1.2	<i>Maximum Peak Conducted Output Power.....</i>	14
5.1.3	<i>Conducted Power Spectral Density.....</i>	15
5.1.4	<i>99%dB Bandwidth.....</i>	16
5.1.5	<i>6dB Bandwidth.....</i>	17
5.1.6	<i>Conducted Spurious Emissions Measured in 100 kHz Bandwidth</i>	18
5.1.7	<i>Radiated Spurious Emission</i>	19
5.1.8	<i>Conducted Emission on AC Mains</i>	20
6	PHOTOGRAPHS OF THE TEST SET-UP	21
7	LIST OF TABLES	21

1 General Remarks

1.1 Complementary Materials

All attachments are integral parts of this test report. This applies especially to the following appendix:

Appendix A: Photographs of the Test Set-up

Appendix B: Test Results.

2 Test Sites

2.1 Test Facilities

TÜV Rheinland (Shenzhen) Co., Ltd.

No. 362 Huanguan Road Middle, Longhua District, 518110, Shenzhen, P. R. China.

FCC Registration No.: 694916

IC Registration No.: 25069

2.2 List of Test and Measurement Instruments

Table 1: List of Test and Measurement Equipment

Radio Spectrum Testing (SRD-Tonscend)				
Equipment	Manufacturer	Model No.	Serial No.	Cal. Until
EXA Signal Analyzer, Multi-touch	Keysight	N9010B	MY60241175	2022-09-28
MXG X-Series RF Vector Signal Generator	Keysight	N5182B	MY61250137	2022-09-28
EXG X-Series Microwave Analog Signal Generator	Keysight	N5173B	MY61250141	2022-09-28
DC power supply	Keysight	E3642A	MY61276100	2022-09-28
Power Control Unit	Tonscend	JS0806-4ADC	N/A	2022-09-28
Automation Control Unit	Tonscend	JS0806-2	21C8060396	2022-09-28
Test Software	Tonscend	JS1120-3	N/A	N/A
Control PC	Lenovo	TianYi510S-071MB	YLX23JMF	N/A
Shielding Room 8#	Albatross	SR8	APC17151-SR8	2024-06-22
Unwanted Emission Testing (TS9975)				
Equipment	Manufacturer	Model No.	Serial No.	Cal. Until
EMI Test Receiver	R&S	ESR 7	102021	2022-08-10
Signal Analyzer	R&S	FSV 40	101439	2022-08-09
System Controller Interface	R&S	SCI-100	S10010038	N/A
Filterbank	R&S	Wlan	100759	2022-08-09
OSP	R&S	OSP 120	102040	N/A
Pre-amplifier	R&S	SCU08F1	08320031	2022-08-09
Amplifier	R&S	SCU-18F	180070	2022-08-09
Amplifier	R&S	SCU40A	100475	2022-08-09
Trilog Broadband Antenna (30 MHz - 7 GHz)	Schwarzbeck	VULB 9162	193	2022-08-08
Double-Ridged Antenna (1 -18 GHz)	ETS-LINDGREN	3117	00218717	2022-08-08
Wideband Ridged Horn Antenna (18-40 GHz)	Steatite	QMS-00880	19067	2022-08-08

Active Loop Antenna	Schwarzbeck	FMZB 1513	302	2022-09-13
Test software	R&S	EMC32 (V10.60.10)	N/A	N/A
Control PC	Dell	OptiPlex 7050	36NV9P2	N/A
3m Semi-Anechoic Chamber	Albatross	SAC-3m	APC17151-SAC	2024-06-22

Conducted Emissions				
Equipment	Manufacturer	Model No.	Serial No.	Cal. Until
EMI Test Receiver	R&S	ESR3	102680	2023-02-27
Artificial Mains Network	R&S	ENV216	101445	2023-02-27
EMC32 test software	R&S	EMC32(Ver.10.50.00)	N/A	N/A

2.3 Traceability

All measurement equipment calibrations are traceable to NIM (National Institute of Metrology) or where calibration is performed in other countries, to equivalent nationally recognized standards organizations.

2.4 Calibration

Equipment requiring calibration is calibrated periodically by the manufacturer or according to manufacturer's specifications. Additionally all equipment is verified for proper performance on a regular basis using in house standards or comparisons.

2.5 Measurement Uncertainty

The estimated combined standard uncertainty for radiated emissions and conducted emissions measurements as below table.

Parameter	Uncertainty
Radio Frequency	$\pm 1 \times 10^{-7}$
RF Power (conducted)	± 2.5 dB
Radiated Emission of Transmitter, valid up to 26.5 GHz	± 6 dB
Radiated Emission of Receiver, valid up to 26.5 GHz	± 6 dB
Conducted Emission, (9kHz to 150kHz)/(150kHz to 30MHz)	± 3.70 dB / ± 3.30 dB
Temperature	± 1 °C
Humidity	± 5 %
Voltage (DC)	± 1 %
Voltage (AC, <10kHz)	± 2 %

2.6 Location of Original Data

The original copies of all test data taken during actual testing were attached at Appendix A & B of this report and delivered to the applicant. A copy has been retained in the TÜV Rheinland (Shenzhen) file for certification follow-up purposes.

2.7 Status of Facility Used for Testing

The **TÜV Rheinland (Shenzhen) Co., Ltd.** Test facility located at No. 362 Huanguan Road Middle, Longhua District, 518110, Shenzhen, P. R. China. is listed on the US Federal Communications Commission list of facilities approved to perform measurements.

3 General Product Information

3.1 Product Function and Intended Use

The EUT is **Smartmi Robot Vacuum Cleaner**, which supports Wi-Fi 802.11 b/g/n wireless technology.

For details refer to the User Manual, Technical Description and Circuit Diagram.

3.2 Ratings and System Details

Table 2: Technical Specification of EUT

General Information of EUT	Value
Kind of Equipment:	Smartmi Robot Vacuum Cleaner
Type Designation:	ZNXDJQR01ZM
Trademark:	Smartmi
FCC ID:	2AP98-ZNXDJQR01ZM
IC:	26864-ZNXDJQR01ZM
HVIN:	ZNXDJQR01ZM
Operating Voltage:	AC 100-240V, 50/60Hz input via Power Adapter or DC 14.4V input via rechargeable battery
Testing Voltage:	AC 120V, 60Hz or Fully charged battery
Power Adapter:	Model: KA3601A-1901500US Input: 100-240VAC, 50/60Hz Output: DC 19V, 1.5A
Technical Specification of Wi-Fi 802.11 b/g/n	
Operating Frequency:	2412 - 2462 MHz for 802.11b/g/n(HT20) 2422 - 2452 MHz for 802.11n(HT40)
Type of Modulation:	DSSS(DBPSK/DQPSK/CCK) OFDM(BPSK/QPSK/16QAM/64QAM)
Data Rate:	1/2/5.5/11 Mbps for 802.11b 6/9/12/18/24/36/48/54 Mbps for 802.11g MCS0 ~ MCS7 for 802.11n
Channel Number:	11 channels for 802.11b/g/n(HT20) 7 channels for 802.11n(HT40)
Channel Separation:	5 MHz
Antenna Type:	Integral Antenna
Antenna Gain:	2.0 dBi

Table 3: RF Channel and Frequency of Wi-Fi 802.11 b/g/n

RF Channel	802.11 b/g/n(HT20)	802.11 n(HT40)
	Frequency (MHz)	Frequency (MHz)
01	2412	/
02	2417	/
03	2422	2422
04	2427	2427
05	2432	2432
06	2437	2437
07	2442	2442
08	2447	2447
09	2452	2452
10	2457	/
11	2462	/

Test frequencies are lowest channel: 2412 MHz, middle channel: 2437 MHz and highest channel: 2462 MHz for 802.11b/g/n(HT20)

Test frequencies are lowest channel: 2422 MHz, middle channel: 2437 MHz and highest channel: 2452 MHz for 802.11n(HT40)

3.3 Independent Operation Modes

The basic operation modes are:

- A. On, Wi-Fi transmitting mode
 - 1) Low Channel
 - 2) Middle Channel
 - 3) High Channel
- B. On, Charging and WIFI link mode
- C. Off

3.4 Noise Generating and Noise Suppressing Parts

Refer to Circuit Diagram for further details.

3.5 Submitted Documents

- Application Form
- Operation Description
- User Manual
- FCC/IC Label and Location Info

4 Test Set-up and Operation Modes

4.1 Principle of Configuration Selection

Radio Spectrum: The equipment under test (EUT) was configured at its highest power output in order to measure its highest possible radiation and conducted level. The test modes were adapted accordingly in reference to the instructions for use.

Emission: The equipment under test (EUT) was configured to measure its highest possible radiation level. The test modes were adapted accordingly in reference to the instructions for use.

4.2 Test Operation and Test Software

Test operation refers to test setup in chapter 5. All testing were performed according to the procedures in ANSI C63.10: 2013.

According to clause 3.1, all tests were performed on model ZNXDJQR01ZM in this report.

4.3 Special Accessories and Auxiliary Equipment

Table 4: List of Accessories and Auxiliary Equipment

Description	Manufacturer	Model	S/N
Laptop	Lenovo	T480	PF-16A6N8

4.4 Countermeasures to Achieve EMC Compliance

The test sample which has been tested contained the noise suppression parts as described in the Technical Construction File (TCF).

No additional measures were employed to achieve compliance.

4.5 Test Setup Diagram

Diagram of Measurement Configuration for Radiation Test (Below 1GHz)

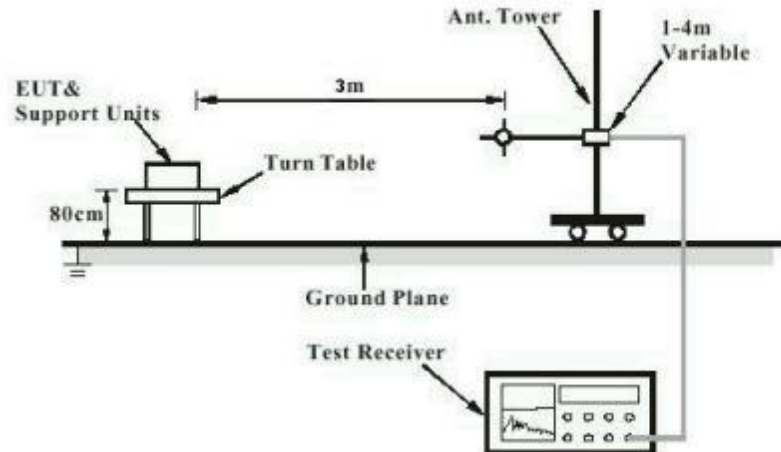

Diagram of Measurement Configuration for Radiation Test (Above 1GHz)

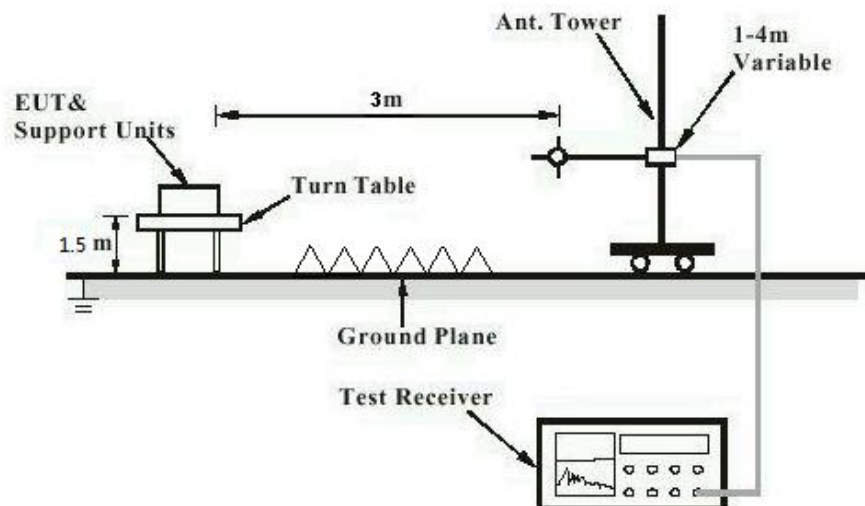

Diagram of Measurement Configuration for Mains Conduction Measurement

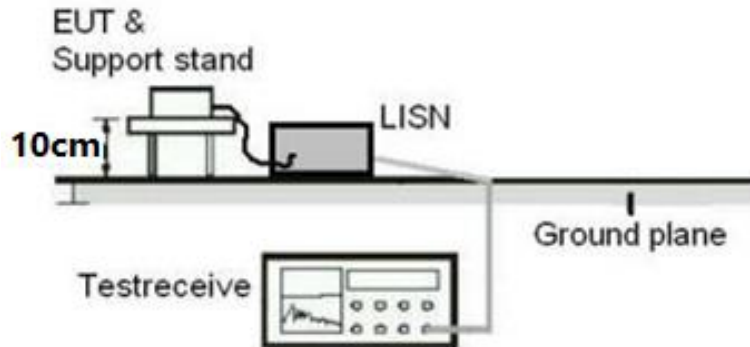
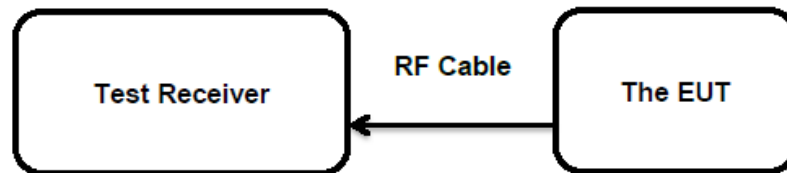

Diagram of Measurement Configuration for Conducted Transmitter Measurement



5 Test Results

5.1 Transmitter Requirement & Test Suites

5.1.1 Antenna Requirement

RESULT: **Pass**

Test Specification

Test standard : FCC Part 15.247(b)(4) and Part 15.203
Limit : the use of antennas with directional gains that do not exceed 6 dBi

According to the manufacturer declared, the EUT has an Integral Antenna, the directional gain of antenna is 2.0 dBi, and the antenna connector is designed with permanent attachment and no consideration of replacement. Therefore the EUT is considered sufficient to comply with the provision.

Refer to EUT Photo for further details.

5.1.2 Maximum Peak Conducted Output Power

RESULT:
Pass
Test Specification

Test standard	: FCC Part 15.247(b)(3) RSS-247 Clause 5.4(2)&(4)
Basic standard	: ANSI C63.10: 2013
Limits	: < 1 W (Maximum Conducted Peak Power) e.i.r.p. <4W
Kind of test site	: Shielded Room

Test Setup

Date of testing	: 2022-06-23 to 2022-06-24
Input voltage	: Fully charged battery
Operation mode	: A
Test channel	: Low / Middle / High
Ambient temperature	: 25 °C
Relative humidity	: 45 %
Atmospheric pressure	: 101 kPa

For details refer to following test result.

Table 5: Test Result of Maximum Peak Conducted Output Power, Wi-Fi 802.11 b/g/n

Test Mode	Data Rate	Test Channel (MHz)	Measured Peak Power		Limit (W)
			(dBm)	(W)	
802.11b	1 Mbps	2412	21.50	0.1413	< 1.0
		2437	21.59	0.1442	
		2462	21.32	0.1355	
802.11g	6 Mbps	2412	20.22	0.1052	
		2437	21.75	0.1496	
		2462	18.15	0.0653	
802.11n (HT20)	MCS0	2412	20.66	0.1164	
		2437	22.64	0.1837	
		2462	18.59	0.0723	
802.11n (HT40)	MCS0	2422	18.93	0.0782	
		2437	20.94	0.1242	
		2452	17.49	0.0561	
Maximum Measured Value			22.64	0.1837	

Note:

- 1) The cable loss is taken into account in results.
- 2) Antenna gain(G): 2.0 dBi

Note: The cable loss is taken into account in results and the e.i.r.p. is 24.64 dBm less than 4W (36 dBm).

Prüfbericht - Nr.: **CN22IMYY 001**
Test Report No.:Seite 15 von 21
Page 15 of 21

5.1.3 Conducted Power Spectral Density

RESULT:**Pass****Test Specification**

Test standard : FCC Part 15.247(e)
RSS-247 Clause 5.2(2)

Basic standard : ANSI C63.10: 2013

Limits : 8 dBm / 3kHz

Kind of test site : Shielded Room

Test Setup

Date of testing : 2022-06-23 to 2022-06-24

Input voltage : Fully charged battery

Operation mode : A

Test channel : Low / Middle / High

Ambient temperature : 25 °C

Relative humidity : 45 %

Atmospheric pressure : 101 kPa

For the measurement records, refer to the appendix B.

Prüfbericht - Nr.: CN22IMYY 001
*Test Report No.:*Seite 16 von 21
Page 16 of 21

5.1.4 99%dB Bandwidth

RESULT:**Pass****Test Specification**

Test standard : RSS-Gen clause 6.7
Basic standard : ANSI C63.10: 2013
Kind of test site : Shielded Room

Test Setup

Date of testing : 2022-06-23 to 2022-06-24
Input voltage : Fully charged battery
Operation mode : A
Test channel : Low / Middle / High
Ambient temperature : 25 °C
Relative humidity : 45 %
Atmospheric pressure : 101 kPa

For the measurement records, refer to the appendix B.

Prüfbericht - Nr.: CN22IMYY 001
Test Report No.:Seite 17 von 21
Page 17 of 21

5.1.5 6dB Bandwidth

RESULT:**Pass****Test Specification**

Test standard : FCC Part 15.247(a)(2)
RSS-247 Clause 5.2(a)

Basic standard : ANSI C63.10: 2013

Limits : > 500 KHz

Kind of test site : Shielded Room

Test Setup

Date of testing : 2022-06-23 to 2022-06-24

Input voltage : Fully charged battery

Operation mode : A

Test channel : Low / Middle / High

Ambient temperature : 25 °C

Relative humidity : 45 %

Atmospheric pressure : 101 kPa

For the measurement records, refer to the appendix B.

5.1.6 Conducted Spurious Emissions Measured in 100 kHz Bandwidth

RESULT: **Pass**

Test Specification

Test standard	: FCC Part 15.247(d) RSS-247 Clause 5.5
Basic standard	: ANSI C63.10: 2013
Limits	: 20dB (below that in the 100kHz bandwidth within the band that contains the highest level of the desired power); In addition, radiated emissions which fall in the restricted bands, must also comply with the radiated emission limits specified in 15.209(a)
Kind of test site	: Shielded Room

Test Setup

Date of testing	: 2022-06-23 to 2022-06-24
Input voltage	: Fully charged battery
Operation mode	: A
Test channel	: Low / Middle / High
Ambient temperature	: 25 °C
Relative humidity	: 45 %
Atmospheric pressure	: 101 kPa

Test results of 100kHz Bandwidth of Frequency Band Edge by Conducted method refer to test plots, and compliance is achieved as well.

For the measurement records, refer to the appendix B.

Prüfbericht - Nr.: **CN22IMYY 001**
Test Report No.:Seite 19 von 21
Page 19 of 21

5.1.7 Radiated Spurious Emission

RESULT:**Pass****Test Specification**

Test standard	:	FCC Part 15.247(d) & FCC Part 15.205 RSS-247 Clause 3.3 & 5.5
Basic standard	:	ANSI C63.10: 2013
Limits	:	Refer to 15.209(a) of FCC part 15.247(d) RSS-Gen Table 4 & Table 5
Kind of test site	:	3m Semi-anechoic Chamber

Test Setup

Date of testing	:	2022-06-13 to 2022-06-23
Input voltage	:	Fully charged battery
Operation mode	:	A
Test channel	:	Low / Middle / High
Ambient temperature	:	Refer to test result
Relative humidity	:	Refer to test result
Atmospheric pressure	:	101 kPa

Remark:

Testing was carried out within frequency range 9kHz to the tenth harmonics. Only the worst case spurious emissions configuration of the each mode were reported.

For the measurement records, refer to the appendix B.

Prüfbericht - Nr.: CN22IMYY 001
*Test Report No.:*Seite 20 von 21
Page 20 of 21

5.1.8 Conducted Emission on AC Mains

RESULT:**Pass****Test Specification**

Test standard : FCC Part 15.207(a)
RSS-Gen Clause 8.8

Basic standard : ANSI C63.10: 2013

Frequency range : 0.15 – 30MHz

Limits : FCC Part 15.207(a)
RSS-Gen Table 4

Kind of test site : Shielded Room

Test Setup

Date of testing : 2022-06-06

Input voltage : AC 120V, 60Hz

Operation mode : B

Earthing : Not connected

Ambient temperature : 24.2 °C

Relative humidity : 51 %

Atmospheric pressure : 101 kPa

For the measurement records, refer to the appendix B.

6 Photographs of the Test Set-Up

For photographs of the test set-up, refer to the appendix A.

7 List of Tables

Table 1: List of Test and Measurement Equipment	5
Table 2: Technical Specification of EUT	8
Table 3: RF Channel and Frequency of Wi-Fi 802.11 b/g/n	9
Table 4: List of Accessories and Auxiliary Equipment.....	10
Table 5: Test Result of Maximum Peak Conducted Output Power, Wi-Fi 802.11 b/g/n.....	14