

Radio Test Report

Report No.: STS2405013W04

Issued for

WHOOOP INTERNATIONAL TRADING LIMITED

Flat-B 8/F Chong Gming Building 72 Cheung Sha Wan Road
Kowloon Hong Kong

Product Name: 4G SMARTPHONE

Brand Name: SUNTAK

Model Name: MOJO

Series Model(s): MOX 2

FCC ID: 2AP7LMOJO

Test Standards: FCC Part15.407

The test results presented in this report relate only to the object tested. This report shall not be reproduced, except in full, without the written approval of the Shenzhen STS Test Services Co., Ltd.



TEST REPORT

Applicant's Name: WHOOP INTERNATIONAL TRADING LIMITED
Address: Flat-B 8/F Chong Gming Building 72 Cheung Sha Wan Road
 Kowloon Hong Kong
Manufacturer's Name.....: Shenzhen Teleone Technology Co., Ltd
Address: Tower B 5/F, Shanshui Building, Nanshan Yungu Innovation Industry
 Park, 4093 Liuxian Avenue, Shenzhen, China

Product Description

Product Name.....: 4G SMARTPHONE
Brand Name.....: SUNTAK
Model Name: MOJO
Series Model(s): MOX 2

Test Standards: FCC Part15.407
Test Procedure..... ANSI C63.10-2020

This device described above has been tested by STS, the test results show that the equipment under test (EUT) is in compliance with the FCC requirements. And it is applicable only to the tested sample identified in the report.

The test results presented in this report relate only to the object tested. This report shall not be reproduced, except in full, without the written approval of the Shenzhen STS Test Services Co., Ltd.

Date of Test:
Date of receipt of test item.....: 08 May 2024
Date (s) of performance of tests: 08 May 2024~ 13 May 2024
Date of Issue: 13 May 2024
Test Result.....: **Pass**

Testing Engineer : Aaron Bu
 (Aaron Bu)

Technical Manager : Chris Chen
 (Chris Chen)

Authorized Signatory : Bovey Yang
 (Bovey Yang)



Table of Contents	Page
1 . SUMMARY OF TEST RESULTS	6
1.1 TEST FACTORY	7
1.2 MEASUREMENT UNCERTAINTY	7
2 . GENERAL INFORMATION	8
2.1 GENERAL DESCRIPTION OF THE EUT	8
2.2 DESCRIPTION OF TEST MODES	11
2.3 TEST SOFTWARE AND POWER LEVEL	12
2.4 BLOCK DIAGRAM SHOWING THE CONFIGURATION OF SYSTEM TESTED	13
2.5 DESCRIPTION OF NECESSARY ACCESSORIES AND SUPPORT UNITS	13
2.6 EQUIPMENTS LIST FOR ALL TEST ITEMS	14
3 . EMC EMISSION TEST	15
3.1 CONDUCTED EMISSION MEASUREMENT	15
3.2 RADIATED EMISSION AND (BANDEDGE) MEASUREMENT	21
4. POWER SPECTRAL DENSITY TEST	89
4.1 LIMIT	89
4.2 TEST PROCEDURE	89
4.3 DEVIATION FROM STANDARD	90
4.4 TEST SETUP	90
4.5 EUT OPERATION CONDITIONS	90
4.6 TEST RESULTS	90
5. BANDWIDTH MEASUREMENT	91
5.1 EMISSION BANDWIDTH (EBW) 26 BANDWID PROCEDURES / LIMIT	91
5.2 OCCUPIED BANDWIDTH (99%) TEST APPLIED PROCEDURES / LIMIT	92
5.3 MINIMUM EMISSION BANDWIDTH(6 DB) PROCEDURES / LIMIT	93
6. MAXIMUM CONDUCTED OUTPUT POWER	94
6.1 LIMIT	94
6.2 TEST PROCEDURE	94
6.3 DEVIATION FROM STANDARD	94
6.4 TEST SETUP	94
6.5 EUT OPERATION CONDITIONS	94
6.6 TEST RESULTS	94
7. AUTOMATICALLY DISCONTINUE TRANSMISSION	95
7.1 LIMIT OF AUTOMATICALLY DISCONTINUE TRANSMISSION	95
7.2 TEST RESULT OF AUTOMATICALLY DISCONTINUE TRANSMISSION	95
8. ANTENNA REQUIREMENT	96



Table of Contents

Page

8.1 STANDARD REQUIREMENT	96
8.2 EUT ANTENNA	96
APPENDIX - PHOTOS OF TEST SETUP	97



Revision History

Rev.	Issue Date	Report No.	Effect Page	Contents
00	13 May 2024	STS2405013W04	ALL	Initial Issue



1. SUMMARY OF TEST RESULTS

Test procedures according to the technical standards:

§ 15.407, KDB 789033 D02 General U-NII Test Procedures New Rules v02r01

FCC Part 15.407		
FCC standard	Test Item	Results
15.207	AC Conducted Emission	PASS
15.407 (a) /15.407 (e)	26dB/6dB &99% Bandwidth	PASS
15.407(a)	Maximum Conducted Output Power	PASS
15.407(b)/15.205/15.209	Radiated Emission And (bandedge Emissions) Measurement	PASS
15.407(a)	Power Spectral Density	PASS
15.407(c)	Automatically Discontinue Transmission	PASS
15.203/15.204	Antenna Requirement	PASS

NOTE:

- (1) 'N/A' denotes test is not applicable in this Test Report.
- (2) All tests are according to ANSI C63.10-2020.



1.1 TEST FACTORY

SHENZHEN STS TEST SERVICES CO., LTD

Add. : 101, Building B, Zhuoke Science Park, No.190 Chongqing Road, ZhanChengShequ, Fuhai Sub-District, Bao'an District, Shenzhen, Guang Dong, China

FCC test Firm Registration Number: 625569

IC test Firm Registration Number: 12108A

A2LA Certificate No.: 4338.01

1.2 MEASUREMENT UNCERTAINTY

The reported uncertainty of measurement $y \pm U$, where expanded uncertainty U is based on a standard uncertainty multiplied by a coverage factor of $k=2$, providing a level of confidence of approximately **95** %.

No.	Item	Uncertainty
1	RF output power, conducted	$\pm 0.755\text{dB}$
2	Unwanted Emissions, conducted	$\pm 2.874\text{dB}$
3	All emissions, radiated 9K-30MHz	$\pm 3.80\text{dB}$
4	All emissions, radiated 30M-1GHz	$\pm 4.18\text{dB}$
5	All emissions, radiated 1G-6GHz	$\pm 4.90\text{dB}$
6	All emissions, radiated >6G	$\pm 5.24\text{dB}$
7	Conducted Emission (9KHz-150KHz)	$\pm 2.19\text{dB}$
8	Conducted Emission (150KHz-30MHz)	$\pm 2.53\text{dB}$
9	Occupied Channel Bandwidth	$\pm 3.5\%$
10	Power Spectral Density, conducted	$\pm 1.245\text{dB}$
11	Duty Cycle	$\pm 3.2\%$

2. GENERAL INFORMATION

2.1 GENERAL DESCRIPTION OF THE EUT

Product Name	4G SMARTPHONE		
Brand Name	SUNTAK		
Model Name	MOJO		
Series Model(s)	MOX 2		
Model Difference	They only have different camera pixels, memory sizes, antennas, appearances, and everything else is exactly the same		
Product Description	The EUT is a 4G SMARTPHONE		
	Operation Frequency:	IEEE 802.11a/ n(HT20)/ac(VHT20): 5.180GHz-5.240GHz IEEE 802.11ac(VHT40): 5.190GHz-5.230GHz IEEE 802.11ac(VHT80): 5.210GHz	
		IEEE 802.11a/ n(HT20)/ac(VHT20): 5.260GHz-5.320GHz IEEE 802.11 ac(VHT40): 5.270GHz-5.310GHz IEEE 802.11 ac(VHT80): 5.290GHz	
		IEEE 802.11a/ n(HT20)/ac(VHT20): 5.500GHz-5.700GHz IEEE 802.11 ac(VHT40):5.510GHz-5.670GHz IEEE 802.11 ac(VHT80): 5.530GHz-5.610GHz	
		IEEE 802.11a/ n(HT20)/ac(VHT20): 5.745GHz-5.825GHz IEEE 802.11ac(VHT40):5.755GHz-5.795GHz IEEE 802.11ac(VHT80): 5.775GHz	
		Modulation Type:	802.11a(OFDM): BPSK,QPSK,16-QAM,64-QAM 802.11n(OFDM): BPSK,QPSK,16-QAM,64-QAM 802.11ac(OFDM): BPSK,QPSK,16-QAM,64-QAM,256-QAM
		Antenna Type:	PIFA Antenna
		Antenna Gain (dBi):	0.75 dBi
	Max.Output Power(Conducted):	11.84dBm	
	More details of EUT technical specification, please refer to the User Manual.		
Test Channel	Please refer to the Note 3.		
Adapter	Input: AC 100-240V, 0.2A,50-60Hz Output: DC 5V,2A		
Battery	Rated Voltage: DC3.85V Charge Limit Voltage: 4.4V Capacity: 5000mAh		
Hardware version number	T341_9230_MB_D4F_V1.0		
Software version number	ROVER_MOJO_14_V01_20240426		
Connecting I/O Port(s)	Please refer to the Note 1.		

Note

1. For a more detailed features description, please refer to the manufacturer's specifications or the User Manual.
2. The antenna information refer the manufacturer provide report, applicable only to the tested sample identified in the report. Due to the incorrect antenna information, a series of problems such as the accuracy of the test results will be borne by the customer.

3. Operation Frequency of channel

5.180GHz-5.240GHz		5.500GHz-5.720GHz	
Channel	Frequency	Channel	Frequency
36	5180	100	5500
38	5190	102	5510
40	5200	104	5520
42	5210	106	5530
44	5220	108	5540
46	5230	110	5550
48	5240	112	5560
		116	5580
		118	5590
5.260GHz-5.320GHz			
Channel	Frequency	120	5600
52	5260	122	5610
54	5270	124	5620
56	5280	126	5630
58	5290	128	5640
60	5300	132	5660
62	5310	134	5670
64	5320	136	5680
		140	5700
5.745GHz-5.825GHz			
Channel	Frequency		
149	5745		
151	5755		
153	5765		
157	5785		
159	5795		
161	5805		
165	5825		

Note:

In section 15.31(m), regards to the operating frequency range over 10 MHz, the Lowest frequency, the middle frequency, and the highest frequency of channel were selected to perform the test, and the selected channel see below:

Carrier Frequency Channel

5GHz:

For 802.11a/n(HT20)/ac(VHT20)			
Channel	Freq.(MHz)	Channel	Freq.(MHz)
36	5180	52	5260
40	5200	60	5300
48	5240	64	5320

For 802.11a/n(HT20)/ac(VHT20)			
Channel	Freq.(MHz)	Channel	Freq.(MHz)
100	5500	149	5745
116	5580	157	5785
140	5700	165	5825

For 802.11 ac(VHT40)			
Channel	Freq.(MHz)	Channel	Freq.(MHz)
38	5190	54	5270
46	5230	62	5310

For 802.11 ac(VHT40)			
Channel	Freq.(MHz)	Channel	Freq.(MHz)
102	5510	151	5755
110	5550	159	5795
134	5670		

For 802.11ac (VHT80)			
Channel	Freq.(MHz)	Channel	Freq.(MHz)
42	5210	58	5290

For 802.11ac (VHT80)			
Channel	Freq.(MHz)	Channel	Freq.(MHz)
106	5530	155	5775
122	5610		

3. KDB 662911 D01 Multiple Transmitter Output v02r01

2) Directional Gain Calculations for In-Band Measurements

a) Basic methodology with NANT transmit antennas, each with the same directional gain G_{ANT} dBi, being driven by NANT transmitter outputs of equal power. Directional gain is to be computed as follows:

(i) If any transmit signals are correlated with each other,
 Directional gain = $G_{ANT} + 10 \log(NANT)$ dBi

(ii) If all transmit signals are completely uncorrelated with each other,
 Directional gain = G_{ANT}



2.2 DESCRIPTION OF TEST MODES

To investigate the maximum EMI emission characteristics generated from EUT, the test system was pre-scanning tested based on the consideration of following EUT operation mode or test configuration mode which possibly have effect on EMI emission level. Each of these EUT operation mode(s) or test configuration mode(s) mentioned above was evaluated respectively.

Worst Mode	Description	Data Rate
Mode 1	TX IEEE 802.11a HT20 CH36&CH40&CH48	6 Mbps
Mode 2	TX IEEE 802.11a HT20 CH52&CH60&CH64	6 Mbps
Mode 3	TX IEEE 802.11a HT20 CH100&CH116&CH140	6 Mbps
Mode 4	TX IEEE 802.11a HT20 CH149&CH157&CH165	6 Mbps
Mode 5	TX IEEE 802.11n HT20 CH36&CH40&CH48	MCS 0
Mode 6	TX IEEE 802.11ac VHT20 CH36&CH40&CH48	NSS1 MCS0
Mode 7	TX IEEE 802.11n HT20 CH52&CH60&CH64	MCS 0
Mode 8	TX IEEE 802.11ac VHT20 CH52&CH60&CH64	NSS1 MCS0
Mode 9	TX IEEE 802.11n HT20 CH100&CH116&CH140	MCS 0
Mode 10	TX IEEE 802.11ac VHT20 CH100&CH116&CH140	NSS1 MCS0
Mode 11	TX IEEE 802.11n HT20 CH149&CH157&CH165	MCS 0
Mode 12	TX IEEE 802.11ac VHT20 CH149&CH157&CH165	NSS1 MCS0
Mode 13	TX IEEE 802.11ac VHT40 CH38&CH46	NSS1 MCS0
Mode 14	TX IEEE 802.11ac VHT40 CH54 &CH62	NSS1 MCS0
Mode 15	TX IEEE 802.11ac VHT40 CH102&CH110&CH134	NSS1 MCS0
Mode 16	TX IEEE 802.11ac VHT40 CH151&CH159	NSS1 MCS0
Mode 17	TX IEEE 802.11ac VHT80 CH42	NSS1 MCS0
Mode 18	TX IEEE 802.11ac VHT80 CH58	NSS1 MCS0
Mode 19	TX IEEE 802.11ac VHT80 CH106&122	NSS1 MCS0
Mode 20	TX IEEE 802.11ac VHT80 CH155	NSS1 MCS0

- Note: (1) The measurements are performed at the highest, middle, lowest available channels.
 (2) The measurements are performed at all Bit Rate of Transmitter, the worst data was reported.
 (3) We have been tested for all available U.S. voltage and frequencies (For 120V, 50/60Hz and 240V, 50/60Hz) for which the device is capable of operation.
 (4) The battery is fully-charged during the radiated and RF conducted test.

AC Conducted Emission

Test Case	
AC Conducted Emission	Mode 21: Keeping TX + WLAN Link

2.3 TEST SOFTWARE AND POWER LEVEL

During testing channel & power controlling software provided by the customer was used to control the operating channel as well as the output power level.

RF Function	Type	Mode Or Modulation type	ANT Gain(dBi)	Power Class	Software For Testing
WIFI(5G)	U-NII-1 (5150MHz-5250MHz)	802.11a	0.75	10	Engineering mode
		802.11n(HT20)		10	
		802.11ac(VHT20)		10	
		802.11ac(VHT40)		10	
		802.11ac(VHT80)		10	
RF Function	Type	Mode Or Modulation type	ANT Gain(dBi)	Power Class	Software For Testing
WIFI(5G)	U-NII-2A (5250MHz-5350MHz)	802.11a	0.75	10	Engineering mode
		802.11n(HT20)		10	
		802.11ac(VHT20)		10	
		802.11ac(VHT40)		10	
		802.11ac(VHT80)		10	
RF Function	Type	Mode Or Modulation type	ANT Gain(dBi)	Power Class	Software For Testing
WIFI(5G)	U-NII-2C (5470MHz-5600MHz, 5650-5725 MHz)	802.11a	0.75	10	Engineering mode
		802.11n(HT20)		10	
		802.11ac(VHT20)		10	
		802.11ac(VHT40)		10	
		802.11ac(VHT80)		10	
RF Function	Type	Mode Or Modulation type	ANT Gain(dBi)	Power Class	Software For Testing
WIFI(5G)	U-NII-3 (5725MHz-5895MHz)	802.11a	0.75	15	Engineering mode
		802.11n(HT20)		15	
		802.11ac(VHT20)		15	
		802.11ac(VHT40)		15	
		802.11ac(VHT80)		15	

2.4 BLOCK DIAGRAM SHOWING THE CONFIGURATION OF SYSTEM TESTED

Radiated Spurious Emission Test

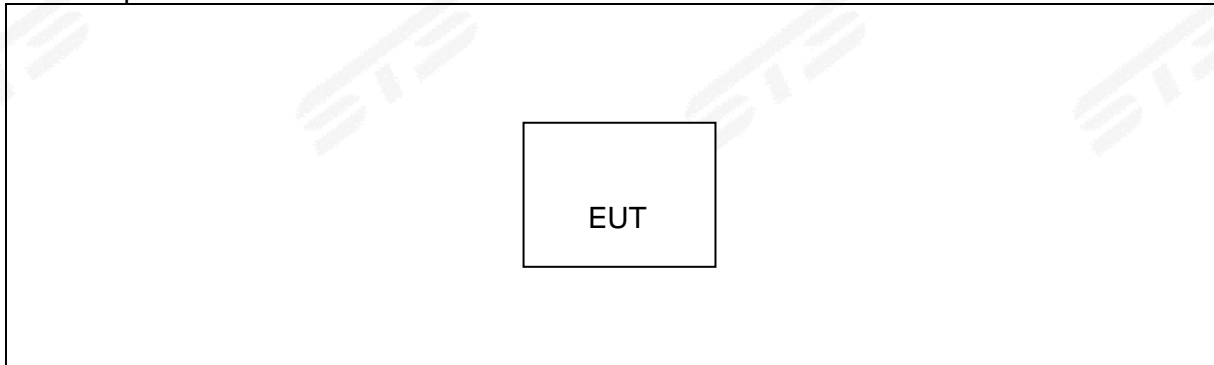

Conducted Emission Test

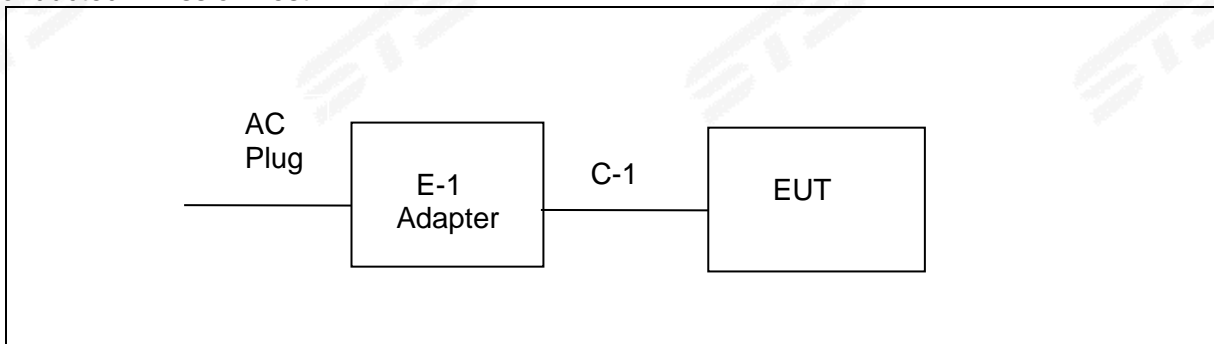

2.5 DESCRIPTION OF NECESSARY ACCESSORIES AND SUPPORT UNITS

The EUT has been tested as an independent unit together with other necessary accessories or support units. The following support units or accessories were used to form a representative test configuration during the tests.

Necessary accessories

Item	Equipment	Mfr/Brand	Model/Type No.	Length	Note
N/A	N/A	N/A	N/A	N/A	N/A

Support units

Item	Equipment	Mfr/Brand	Model/Type No.	Length	Note
E-1	Adapter	SUNTAK	YWK-10W050200	N/A	N/A
C-1	USB Cable	N/A	N/A	150cm	N/A

Note:

- (1) For detachable type I/O cable should be specified the length in cm in 『Length』 column.



2.6 EQUIPMENTS LIST FOR ALL TEST ITEMS

RF Radiation Test Equipment					
Kind of Equipment	Manufacturer	Type No.	Serial No.	Last Calibration	Calibrated Until
Temperature & Humidity	SW-108	SuWei	N/A	2024.03.15	2025.03.14
Pre-Amplifier(0.1M-3GHz)	EM	EM330	060665	2024.02.23	2025.02.22
Pre-Amplifier(1G-18GHz)	SKET	LNPA-01018G-45	SK2018080901	2023.09.26	2024.09.25
Pre-Amplifier(18G-40GHz)	SKET	LNPA_1840-50	SK2018101801	2024.02.23	2025.02.22
Active loop Antenna	ZHINAN	ZN30900C	16035	2023.02.28	2025.02.27
Bilog Antenna	TESEQ	CBL6111D	34678	2022.09.30	2024.09.29
Horn Antenna	SCHWARZBECK	BBHA 9120D	02014	2023.09.24	2025.09.23
Horn Antenna	A-INFOMW	LB-180400-KF	J211020657	2023.10.10	2025.10.09
Positioning Controller	MF	MF-7802	MF-780208587	N/A	N/A
Signal Analyzer	R&S	FSV 40-N	101823	2023.09.26	2024.09.25
Switch Control Box	N/A	N/A	N/A	N/A	N/A
Filter Box	BALUN Technology	SU319E	BL-SZ1530051	N/A	N/A
Antenna Mast	MF	MFA-440H	N/A	N/A	N/A
Turn Table	MF	SC100_1	60531	N/A	N/A
AC Power Source	APC	KDF-11010G	F214050035	N/A	N/A
DC power supply	HONGSHENGFENG	DPS-305AF	17064939	2023.09.26	2024.09.25
Test SW	EZ-EMC	Ver.STSLAB-03A1 RE			
Conduction Test equipment					
Kind of Equipment	Manufacturer	Type No.	Serial No.	Last calibration	Calibrated until
Test Receiver	R&S	ESCI	101427	2023.09.25	2024.09.24
Limtter	CYBERTEK	EM5010	N/A	2023.09.25	2024.09.24
LISN	R&S	ENV216	101242	2023.09.25	2024.09.24
LISN	EMCO	3810/2NM	23625	2023.09.25	2024.09.24
Temperature & Humidity	SW-108	SuWei	N/A	2024.03.15	2025.03.14
Test SW	EZ-EMC	Ver.STSLAB-03A1 CE			
RF Connected Test					
Kind of Equipment	Manufacturer	Type No.	Serial No.	Last calibration	Calibrated until
Signal Analyzer	Agilent	N9020A	MY51510623	2024.02.23	2025.02.22
Switch control box	MW	MW100-RFCB	N/A	N/A	N/A
Temperature & Humidity	SW-108	SuWei	N/A	2024.03.15	2025.03.14
Test SW	MW	MTS 8310_2.0.0.0			

3. EMC EMISSION TEST

3.1 CONDUCTED EMISSION MEASUREMENT

3.1.1 POWER LINE CONDUCTED EMISSION Limits (Frequency Range 150KHz-30MHz)

FREQUENCY (MHz)	Class B (dBuV)		Standard
	Quasi-peak	Average	
0.15 -0.5	66 - 56 *	56 - 46 *	CISPR
0.50 -5.0	56.00	46.00	CISPR
5.0 -30.0	60.00	50.00	CISPR

0.15 -0.5	66 - 56 *	56 - 46 *	FCC
0.50 -5.0	56.00	46.00	FCC
5.0 -30.0	60.00	50.00	FCC

Note:

- (1) The tighter limit applies at the band edges.
- (2) The limit of “ * ” marked band means the limitation decreases linearly with the logarithm of the frequency in the range.

The following table is the setting of the receiver

Receiver Parameters	Setting
Attenuation	10 dB
Start Frequency	0.15 MHz
Stop Frequency	30 MHz
IF Bandwidth	9 kHz

3.1.2 TEST PROCEDURE

- a. The EUT is 0.8 m from the horizontal ground plane and 0.4 m from the vertical ground plane with EUT being connected to the power mains through a line impedance stabilization network (LISN). All other support equipments are powered from additional LISN(s). The LISN provides 50 Ohm/ 50uH of coupling impedance for the measuring instrument.
- b. Interconnecting cables that hang closer than 40 cm to the ground plane shall be folded back and forth in the center forming a bundle 30 to 40 cm long.
- c. I/O cables that are not connected to a peripheral shall be bundled in the center. The end of the cable may be terminated, if required, using the correct terminating impedance. The overall length shall not exceed 1 m.
- d. LISN is at least 80 cm from the nearest part of EUT chassis.
- e. For the actual test configuration, please refer to the related Item –EUT Test Photos.

3.1.3 DEVIATION FROM TEST STANDARD

No deviation

3.1.4 TEST SETUP

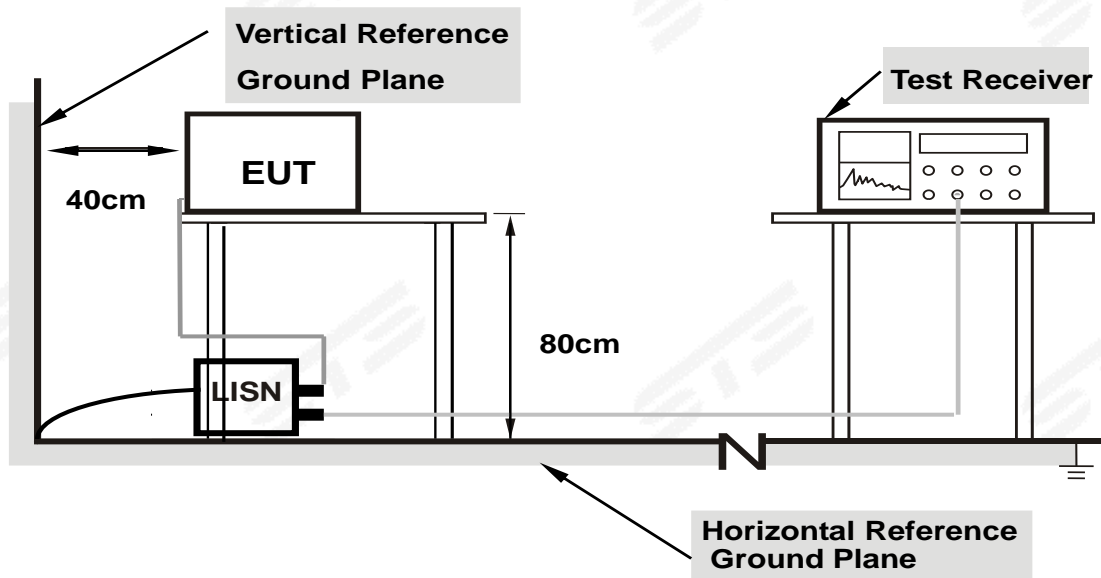

Note: 1. Support units were connected to second LISN.

- 2. Both of LISNs (AMN) are 80 cm from EUT and at least 80 cm from other units and other metal planes support units.**

3.1.5 EUT OPERATING CONDITIONS

The EUT was configured for testing in a typical fashion (as a customer would normally use it). The EUT has been programmed to continuously transmit during test. This operating condition was tested and used to collect the included data.

3.1.6 TEST RESULTS

MOJO

Temperature:	25.1(C)	Relative Humidity:	59%RH
Test Voltage:	AC 120V/60Hz	Phase:	L
Test Mode :	Mode 21		

No.	Frequency (MHz)	Reading (dBUV)	Correct Factor(dB)	Result (dBUV)	Limit (dBUV)	Margin (dB)	Remark
1	0.1540	25.53	19.78	45.31	65.78	-20.47	QP
2	0.1540	10.60	19.78	30.38	55.78	-25.40	AVG
3	0.4180	28.87	20.01	48.88	57.49	-8.61	QP
4	0.4180	17.65	20.01	37.66	47.49	-9.83	AVG
5	1.2060	27.30	19.78	47.08	56.00	-8.92	QP
6	1.2060	12.61	19.78	32.39	46.00	-13.61	AVG
7	2.3820	23.76	19.81	43.57	56.00	-12.43	QP
8	2.3820	8.71	19.81	28.52	46.00	-17.48	AVG
9	3.3460	23.30	19.84	43.14	56.00	-12.86	QP
10	3.3460	8.11	19.84	27.95	46.00	-18.05	AVG
11	14.0540	17.81	20.36	38.17	60.00	-21.83	QP
12	14.0540	2.67	20.36	23.03	50.00	-26.97	AVG

Remark:

1. All readings are Quasi-Peak and Average values
2. Margin = Result (Result =Reading + Factor)–Limit
3. Factor=LISN factor+Cable loss+Limiter (10dB)

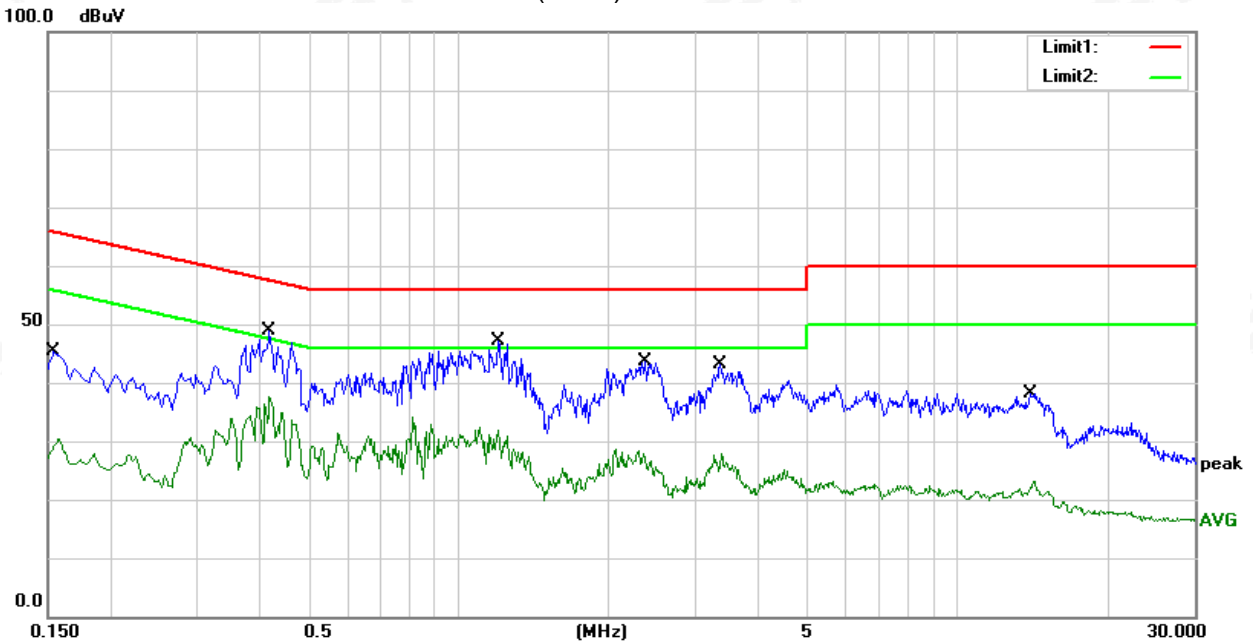



Temperature:	25.1(C)	Relative Humidity:	59%RH
Test Voltage	AC 120V/60Hz	Phase:	N
Test Mode	Mode 21		

No.	Frequency (MHz)	Reading (dBuV)	Correct Factor(dB)	Result (dBuV)	Limit (dBuV)	Margin (dB)	Remark
1	0.1540	25.14	19.78	44.92	65.78	-20.86	QP
2	0.1540	10.19	19.78	29.97	55.78	-25.81	AVG
3	0.4140	28.58	20.01	48.59	57.57	-8.98	QP
4	0.4140	17.04	20.01	37.05	47.57	-10.52	AVG
5	1.1940	27.17	19.78	46.95	56.00	-9.05	QP
6	1.1940	14.51	19.78	34.29	46.00	-11.71	AVG
7	2.4340	24.95	19.81	44.76	56.00	-11.24	QP
8	2.4340	11.45	19.81	31.26	46.00	-14.74	AVG
9	3.4140	22.36	19.84	42.20	56.00	-13.80	QP
10	3.4140	9.61	19.84	29.45	46.00	-16.55	AVG
11	14.5580	16.58	20.36	36.94	60.00	-23.06	QP
12	14.5580	-1.22	20.36	19.14	50.00	-30.86	AVG

Remark:

1. All readings are Quasi-Peak and Average values
2. Margin = Result (Result =Reading + Factor)–Limit
3. Factor=LISN factor+Cable loss+Limiter (10dB)

100.0 dBuV

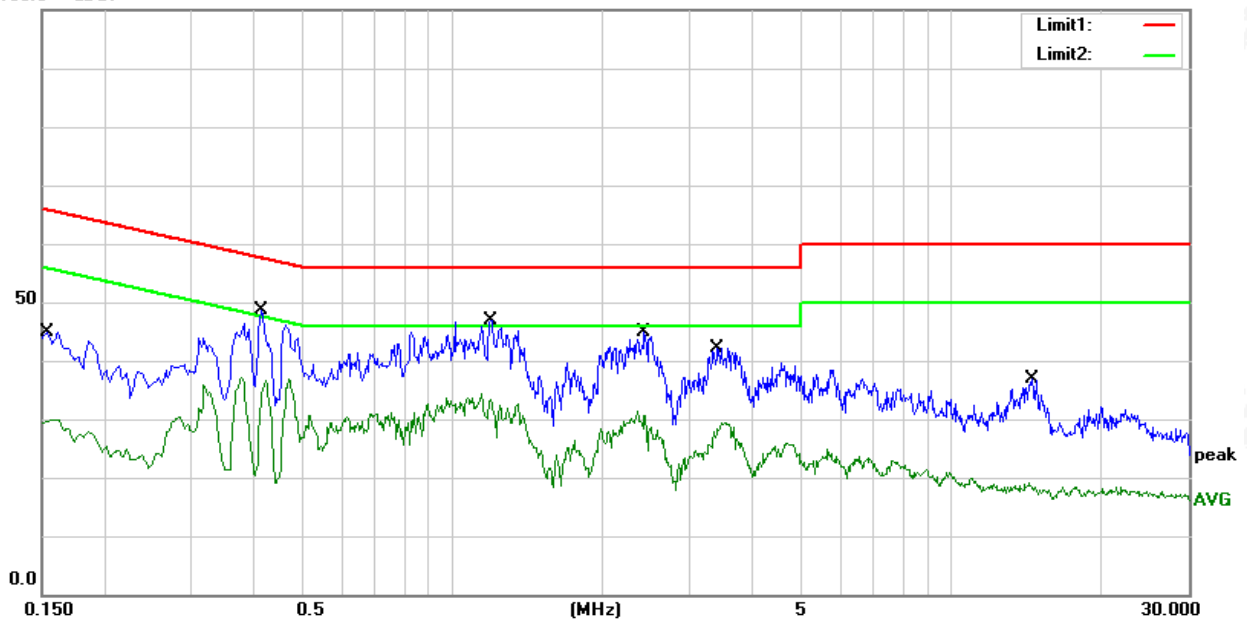



MOX 2

Temperature:	25.1(C)	Relative Humidity:	59%RH
Test Voltage:	AC 120V/60Hz	Phase:	L
Test Mode :	Mode 21		

No.	Frequency (MHz)	Reading (dBUV)	Correct Factor(dB)	Result (dBUV)	Limit (dBUV)	Margin (dB)	Remark
1	0.1620	27.82	19.78	47.60	65.36	-17.76	QP
2	0.1620	12.41	19.78	32.19	55.36	-23.17	AVG
3	0.4140	29.24	20.01	49.25	57.57	-8.32	QP
4	0.4140	15.26	20.01	35.27	47.57	-12.30	AVG
5	1.1980	28.61	19.78	48.39	56.00	-7.61	QP
6	1.1980	13.85	19.78	33.63	46.00	-12.37	AVG
7	2.4300	26.61	19.81	46.42	56.00	-9.58	QP
8	2.4300	8.42	19.81	28.23	46.00	-17.77	AVG
9	3.6620	24.82	19.83	44.65	56.00	-11.35	QP
10	3.6620	7.50	19.83	27.33	46.00	-18.67	AVG
11	14.6700	18.92	20.36	39.28	60.00	-20.72	QP
12	14.6700	3.17	20.36	23.53	50.00	-26.47	AVG

Remark:

1. All readings are Quasi-Peak and Average values
2. Margin = Result (Result =Reading + Factor)–Limit
3. Factor=LISN factor+Cable loss+Limiter (10dB)

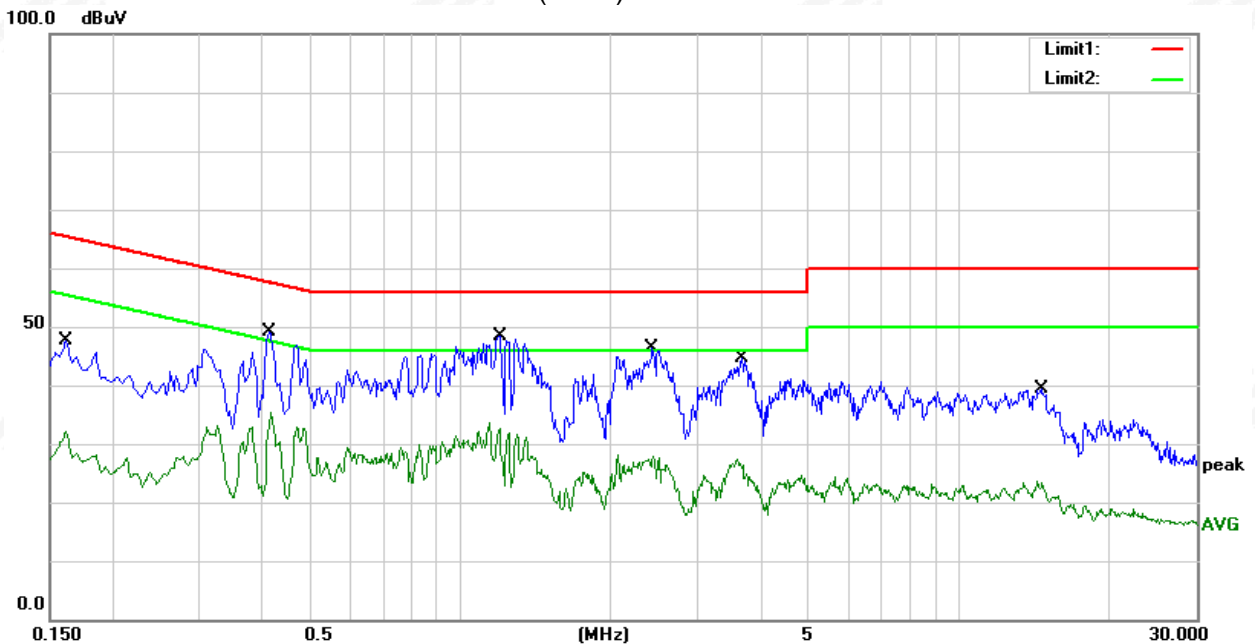



Temperature:	25.1(C)	Relative Humidity:	59%RH
Test Voltage	AC 120V/60Hz	Phase:	N
Test Mode	Mode 21		

No.	Frequency (MHz)	Reading (dBuV)	Correct Factor(dB)	Result (dBuV)	Limit (dBuV)	Margin (dB)	Remark
1	0.1580	29.06	19.78	48.84	65.57	-16.73	QP
2	0.1580	12.73	19.78	32.51	55.57	-23.06	AVG
3	0.4140	27.84	20.01	47.85	57.57	-9.72	QP
4	0.4140	16.10	20.01	36.11	47.57	-11.46	AVG
5	1.2020	27.60	19.78	47.38	56.00	-8.62	QP
6	1.2020	15.39	19.78	35.17	46.00	-10.83	AVG
7	2.5020	25.04	19.81	44.85	56.00	-11.15	QP
8	2.5020	11.65	19.81	31.46	46.00	-14.54	AVG
9	3.5900	23.91	19.83	43.74	56.00	-12.26	QP
10	3.5900	10.95	19.83	30.78	46.00	-15.22	AVG
11	14.5900	17.43	20.36	37.79	60.00	-22.21	QP
12	14.5900	-0.89	20.36	19.47	50.00	-30.53	AVG

Remark:

- 1. All readings are Quasi-Peak and Average values
- 2. Margin = Result (Result =Reading + Factor)–Limit
- 3. Factor=LISN factor+Cable loss+Limiter (10dB)

100.0 dBuV

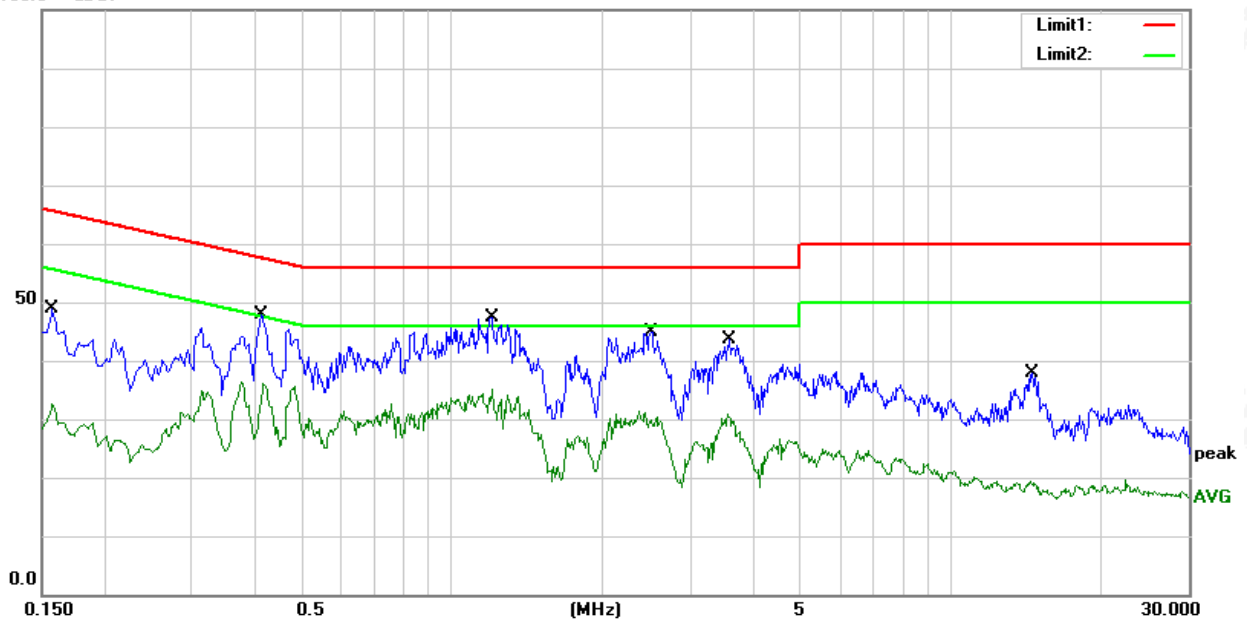

3.2 RADIATED EMISSION AND (BANDEDGE) MEASUREMENT

3.2.1 RADIATED EMISSION LIMITS (Frequency Range 9kHz-1000MHz)

In case the emission fall within the restricted band specified on 15.407(b)7&15.205/209(a), then the limit in the table below has to be followed.

Frequencies (MHz)	Field Strength (micorvolts/meter)	Measurement Distance (meters)
0.009~0.490	2400/F(KHz)	300
0.490~1.705	24000/F(KHz)	30
1.705~30.0	30	30
30~88	100	3
88~216	150	3
216~960	200	3
Above 960	500	3

LIMITS OF RADIATED EMISSION MEASUREMENT (Above 1000MHz)

FREQUENCY (MHz)	Class B (dBuV/m) (at 3M)	
	PEAK	AVERAGE
Above 1000	68.2	54

Notes:

- (1) The limit for radiated test was performed according to FCC PART 15E.
- (2) The tighter limit applies at the band edges.
- (3) Emission level (dBuV/m)=20log Emission level (uV/m).

LIMITS OF RESTRICTED FREQUENCY BANDS

FREQUENCY (MHz)	FREQUENCY (MHz)	FREQUENCY (MHz)	FREQUENCY (GHz)
0.090-0.110	16.42-16.423	399.9-410	4.5-5.15
0.495-0.505	16.69475-16.69525	608-614	5.35-5.46
2.1735-2.1905	16.80425-16.80475	960-1240	7.25-7.75
4.125-4.128	25.5-25.67	1300-1427	8.025-8.5
4.17725-4.17775	37.5-38.25	1435-1626.5	9.0-9.2
4.20725-4.20775	73-74.6	1645.5-1646.5	9.3-9.5
6.215-6.218	74.8-75.2	1660-1710	10.6-12.7
6.26775-6.26825	108-121.94	1718.8-1722.2	13.25-13.4
6.31175-6.31225	123-138	2200-2300	14.47-14.5
8.291-8.294	149.9-150.05	2310-2390	15.35-16.2
8.362-8.366	156.52475-156.52525	2483.5-2500	17.7-21.4
8.37625-8.38675	156.7-156.9	2690-2900	22.01-23.12
8.41425-8.41475	162.0125-167.17	3260-3267	23.6-24.0
12.29-12.293	167.72-173.2	3332-3339	31.2-31.8
12.51975-12.52025	240-285	3345.8-3358	36.43-36.5
12.57675-12.57725	322-335.4	3600-4400	Above 38.6
13.36-13.41			

Note: In case the emission radiated emission above 1000MHz fall within the restricted band the restricted frequency bands, the peak limit is 74 dBuV/m.

LIMITS OF EMISSIONS OUTSIDE OF THE FREQUENCY BANDS

Undesirable emission limits. Except as shown in paragraph (b)(7) of this section, the maximum emissions outside of the frequency bands of operation shall be attenuated in accordance with the following limits:

- (1) For transmitters operating in the 5.15-5.25 GHz band: All emissions outside of the 5.15-5.35 GHz band shall not exceed an e.i.r.p. of -27 dBm/MHz.
- (2) For transmitters operating in the 5.25-5.35 GHz band: All emissions outside of the 5.15-5.35 GHz band shall not exceed an e.i.r.p. of -27 dBm/MHz.
- (3) For transmitters operating in the 5.47-5.725 GHz band: All emissions outside of the 5.47-5.725 GHz band shall not exceed an e.i.r.p. of -27 dBm/MHz.
- (4) For transmitters operating in the 5.725-5.85 GHz band:
 - (i) All emissions shall be limited to a level of -27 dBm/MHz at 75 MHz or more above or below the band edge increasing linearly to 10 dBm/MHz at 25 MHz above or below the band edge, and from 25 MHz above or below the band edge increasing linearly to a level of 15.6 dBm/MHz at 5 MHz above or below the band edge, and from 5 MHz above or below the band edge increasing linearly to a level of 27 dBm/MHz at the band edge.

Note: dBuV/m(at 3M) = EIRP(dBm) + 95.2.

Peak Limit = -27dBm/MHz + 95.2 = 68.2 dBuV/m.

Spectrum Parameter	Setting
Attenuation	Auto
Detector	Peak
Start Frequency	1000 MHz(Peak/AV)
Stop Frequency	10th carrier harmonic (Peak/AV)
RB / VB (emission in restricted band)	1 MHz / 1 MHz, AV=1 MHz /3 MHz

For Band edge

Spectrum Parameter	Setting
Detector	Peak
RB / VB (emission in restricted band)	1 MHz / 1 MHz, AV=1 MHz /3 MHz

Receiver Parameter	Setting
Attenuation	Auto
Start ~ Stop Frequency	9kHz~90kHz / RB 200Hz for PK & AV
Start ~ Stop Frequency	90kHz~110kHz / RB 200Hz for QP
Start ~ Stop Frequency	110kHz~490kHz / RB 200Hz for PK & AV
Start ~ Stop Frequency	490kHz~30MHz / RB 9kHz for QP
Start ~ Stop Frequency	30MHz~1000MHz / RB 120kHz for QP

3.2.2 TEST PROCEDURE

- a. The measuring distance at 3 m shall be used for measurements at frequency 0.009MHz up to 1GHz, and above 1GHz.
- b. The EUT was placed on the top of a rotating table 0.8 m (above 1GHz is 1.5 m) above the ground at a 3 m anechoic chamber test site. The table was rotated 360 degree to determine the position of the highest radiation.
- c. The height of the equipment shall be 0.8 m (above 1GHz is 1.5 m); the height of the test antenna shall vary between 1 m to 4 m. Horizontal and vertical polarization of the antenna are set to make the measurement.
- d. The initial step in collecting conducted emission data is a spectrum analyzer peak detector mode pre-scanning the measurement frequency range. Significant peaks are then marked and QuasiPeak detector mode will be re-measured.
- e. If the Peak Mode measured value is compliance with and lower than Quasi Peak Mode Limit, the EUT shall be deemed to meet QP Limits and no additional QP Mode measurement was performed.
- f. For the actual test configuration, please refer to the related Item –EUT Test Photos.

Note:

Both horizontal and vertical antenna polarities were tested and performed pretest to three orthogonal axis. The worst case emissions were reported.

3.2.2 DEVIATION FROM TEST STANDARD

No deviation

3.2.3 TEST SETUP

(A) Radiated Emission Test-Up Frequency Below 30MHz

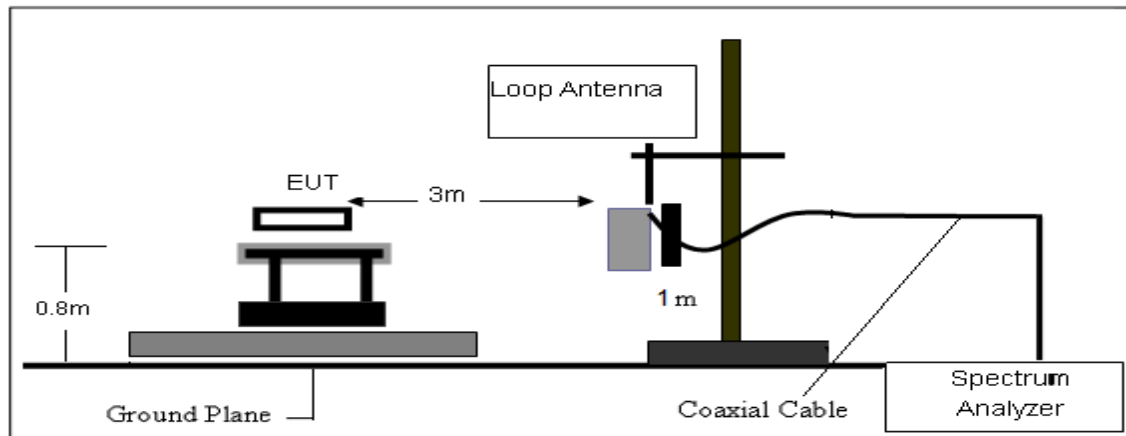

(B) Radiated Emission Test-Up Frequency 30MHz~1GHz

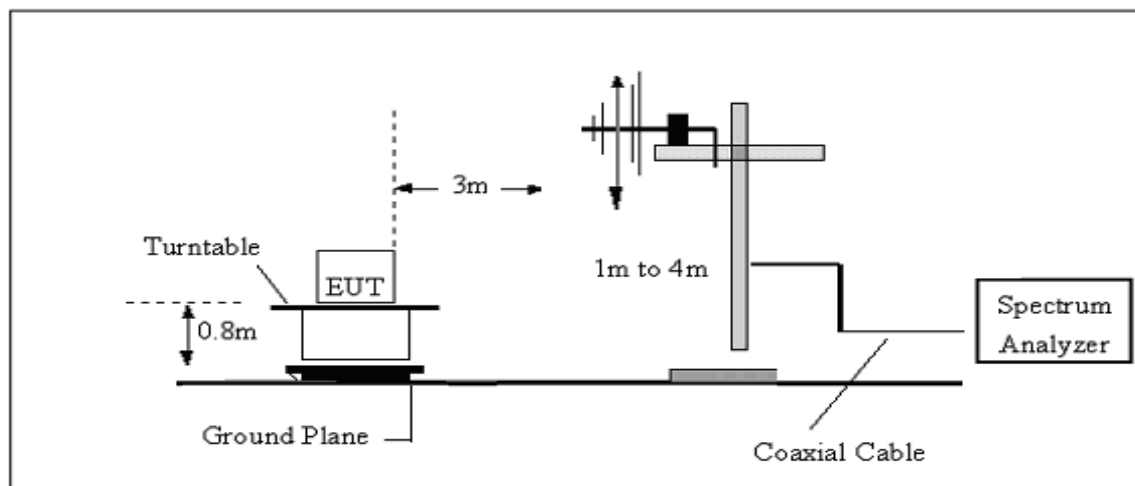

(C) Radiated Emission Test-Up Frequency Above 1GHz

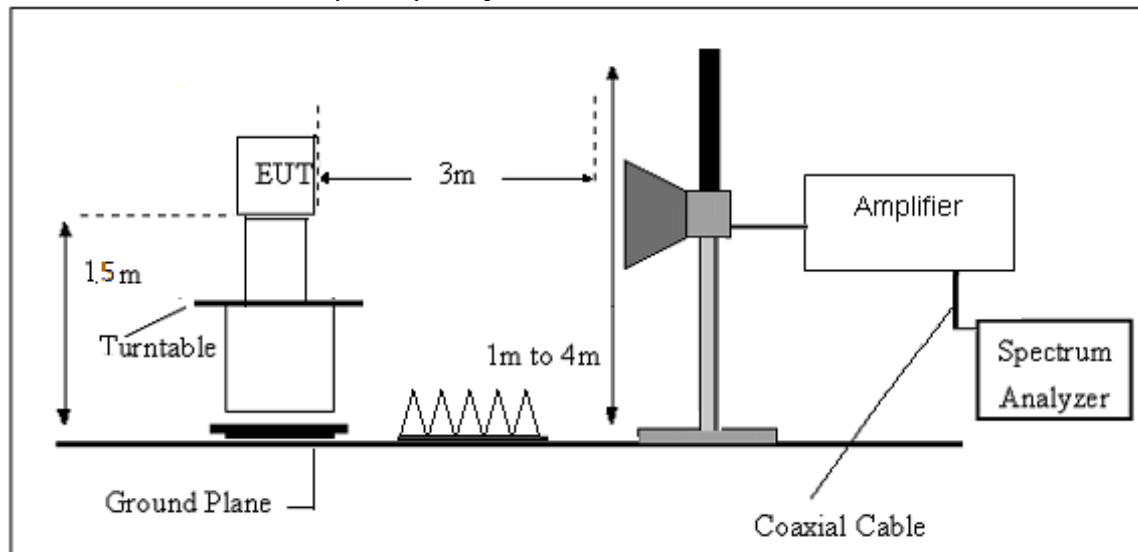

3.2.4 EUT OPERATING CONDITIONS

The EUT tested system was configured as the statements of 2.4 Unless otherwise a special operating condition is specified in the follows during the testing.

3.2.5 FIELD STRENGTH CALCULATION

The field strength is calculated by adding the Antenna Factor and Cable Factor and subtracting the Amplifier Gain and Duty Cycle Correction Factor (if any) from the measured reading. The basic equation with a sample calculation is as follows:

$$FS = RA + AF + CL - AG$$

Where

FS = Field Strength

CL = Cable Attenuation Factor (Cable Loss)

RA = Reading Amplitude

AG = Amplifier Gain

AF = Antenna Factor

For example

Frequency (MHz)	FS (dB μ V/m)	RA (dB μ V/m)	AF (dB)	CL (dB)	AG (dB)	Factor (dB)
300	40	58.1	12.2	1.6	31.9	-18.1

$$\text{Factor} = \text{AF} + \text{CL} - \text{AG}$$

**3.2.6 TEST RESULTS (Between 9KHz – 30 MHz)**

Temperature:	23.1(C)	Relative Humidity:	60%RH
Test Voltage:	DC 3.85V	Polarization :	--
Test Mode:	TX Mode		

Freq. (MHz)	Reading (dBuV/m)	Limit (dBuV/m)	Margin (dB)	State P/F
--	--	--	--	PASS
--	--	--	--	PASS

Note:

The amplitude of spurious emissions which are attenuated by more than 20dB below the permissible value has no need to be reported.

Distance extrapolation factor = $40 \log (\text{specific distance}/\text{test distance})$ (dB);

Limit line = specific limits(dBuv) + distance extrapolation factor.

3.2.7 TEST RESULTS (Between 30MHz – 1GHz)

MOJO

Temperature	23.1(C)	Relative Humidity:	60%RH
Test Voltage	DC 3.85V	Polarization:	Horizontal
Test Mode	Mode 1~20(Mode 4 worst mode)		

No.	Frequency (MHz)	Reading (dBuV)	Correct Factor(dB/m)	Result (dBuV/m)	Limit (dBuV/m)	Margin (dB)	Remark
1	30.9700	31.25	-13.35	17.90	40.00	-22.10	peak
2	147.3700	30.20	-18.42	11.78	43.50	-31.72	peak
3	269.5900	30.27	-15.29	14.98	46.00	-31.02	peak
4	554.7700	29.20	-5.63	23.57	46.00	-22.43	peak
5	733.2500	30.34	-2.35	27.99	46.00	-18.01	peak
6	903.0000	34.48	-0.37	34.11	46.00	-11.89	peak

Remark:

1. Margin = Result (Result =Reading + Factor) –Limit
2. Factor= Antenna factor+Cable attenuation factor(cable loss)-Amplifier gain

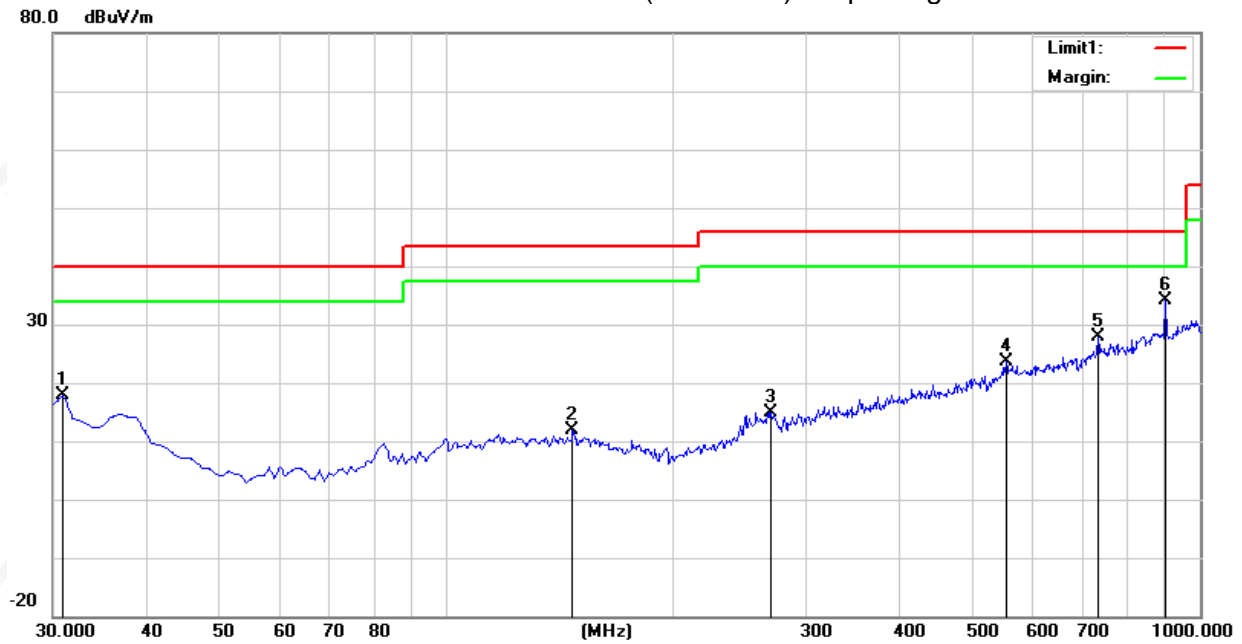

Temperature	23.1(C)	Relative Humidity:	60%RH
Test Voltage	DC 3.85V	Polarization:	Vertical
Test Mode	Mode 1~20(Mode 4 worst mode)		

No.	Frequency (MHz)	Reading (dBuV)	Correct Factor(dB/m)	Result (dBuV/m)	Limit (dBuV/m)	Margin (dB)	Remark
1	30.9700	35.32	-13.35	21.97	40.00	-18.03	peak
2	38.7300	39.54	-17.36	22.18	40.00	-17.82	peak
3	93.0500	40.77	-21.04	19.73	43.50	-23.77	peak
4	406.3600	36.63	-10.77	25.86	46.00	-20.14	peak
5	632.3700	28.47	-5.00	23.47	46.00	-22.53	peak
6	963.1400	29.25	1.84	31.09	54.00	-22.91	peak

Remark:

- Margin = Result (Result =Reading + Factor)-Limit
- Factor= Antenna factor+Cable attenuation factor(cable loss)-Amplifier gain

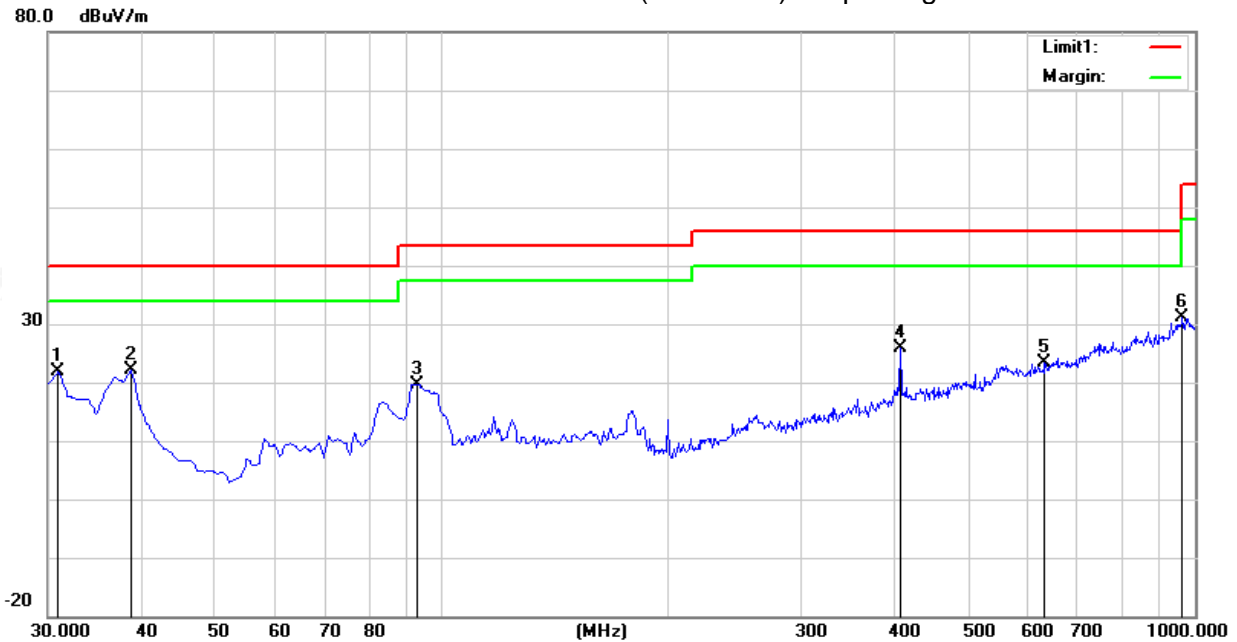

MOX 2

Temperature	23.1(C)	Relative Humidity:	60%RH
Test Voltage	DC 3.85V	Polarization:	Horizontal
Test Mode	Mode 1~20(Mode 4 worst mode)		

No.	Frequency (MHz)	Reading (dBuV)	Correct Factor(dB/m)	Result (dBuV/m)	Limit (dBuV/m)	Margin (dB)	Remark
1	30.5306	30.28	-13.12	17.16	40.00	-22.84	peak
2	270.5600	31.89	-15.34	16.55	46.00	-29.45	peak
3	464.5600	29.52	-9.25	20.27	46.00	-25.73	peak
4	554.7700	29.26	-5.63	23.63	46.00	-22.37	peak
5	733.2500	29.07	-2.35	26.72	46.00	-19.28	peak
6	981.5700	28.45	2.57	31.02	54.00	-22.98	peak

Remark:

- Margin = Result (Result =Reading + Factor) –Limit
- Factor= Antenna factor+Cable attenuation factor(cable loss)-Amplifier gain

80.0 dBuV/m

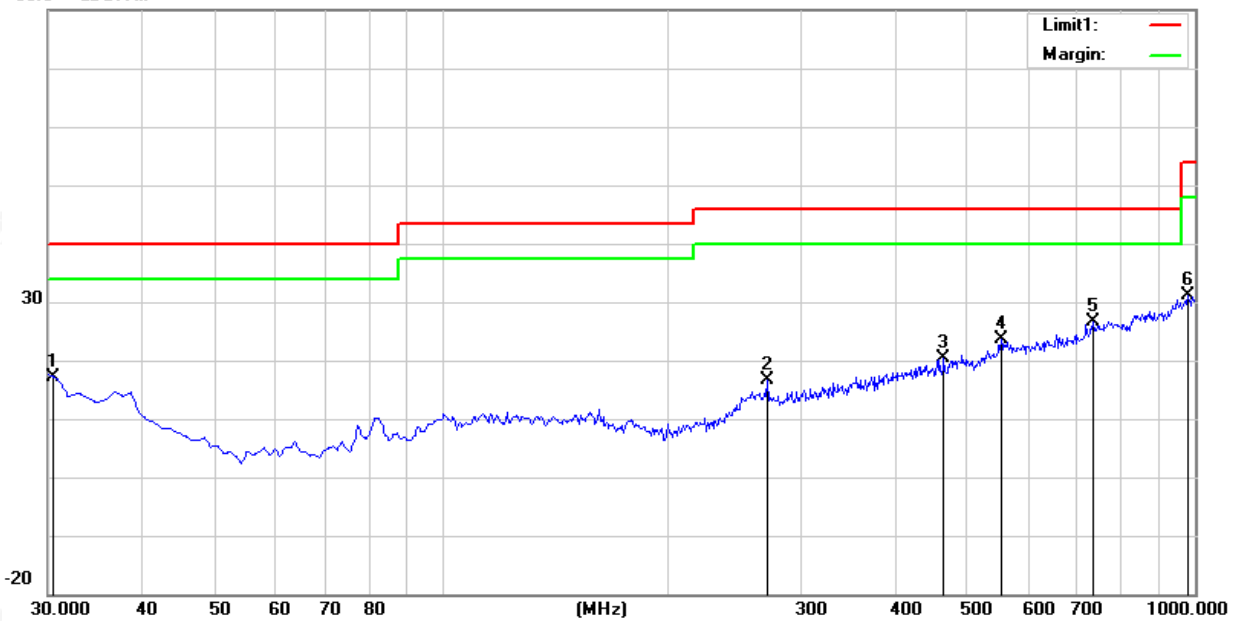

Temperature	23.1(C)	Relative Humidity:	60%RH
Test Voltage	DC 3.85V	Polarization:	Vertical
Test Mode	Mode 1~20(Mode 4 worst mode)		

No.	Frequency (MHz)	Reading (dBuV)	Correct Factor(dB/m)	Result (dBuV/m)	Limit (dBuV/m)	Margin (dB)	Remark
1	30.9700	35.40	-13.35	22.05	40.00	-17.95	peak
2	37.7600	37.60	-16.85	20.75	40.00	-19.25	peak
3	95.9600	41.35	-20.67	20.68	43.50	-22.82	peak
4	433.5200	31.75	-10.13	21.62	46.00	-24.38	peak
5	782.7200	31.39	-2.14	29.25	46.00	-16.75	peak
6	963.1400	29.19	1.84	31.03	54.00	-22.97	peak

Remark:

3. Margin = Result (Result =Reading + Factor)-Limit

4. Factor= Antenna factor+Cable attenuation factor(cable loss)-Amplifier gain

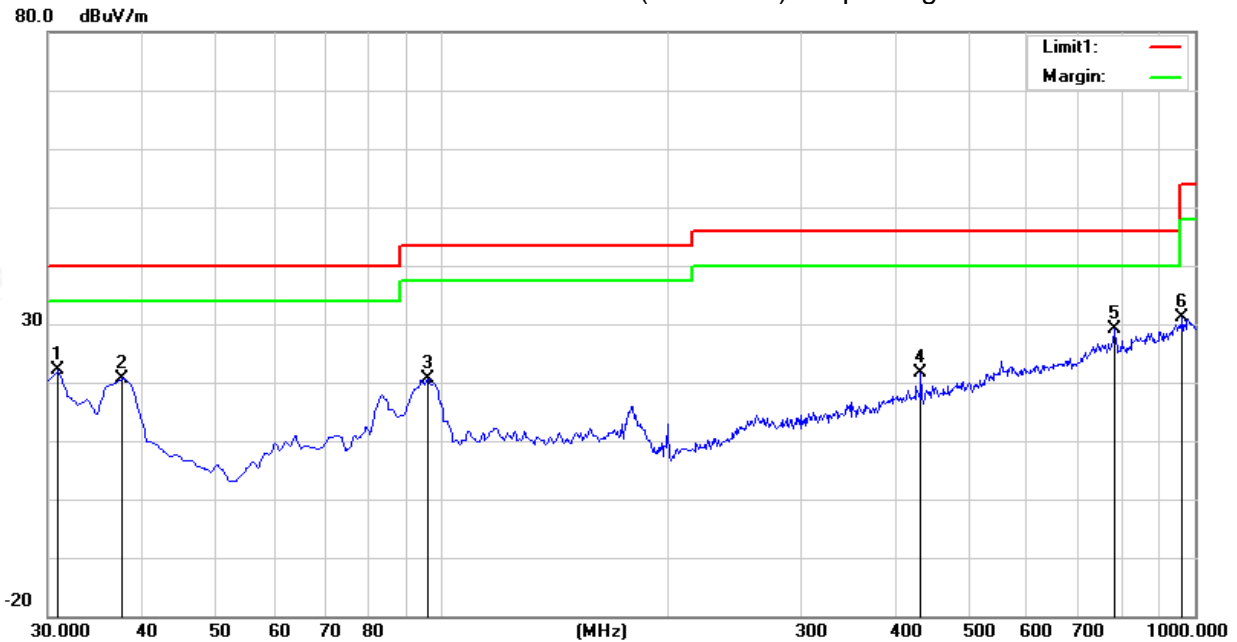



3.2.8 TEST RESULTS (Above 1000 MHz)

MOJO

U-NII-1 5150-5250MHz

Band I(5.15-5.25) GHz										
Frequency (MHz)	Reading (dBuV)	Amplifier (dB)	Loss (dB)	Antenna Factor (dB/m)	Orrected Factor (dB)	Emission Level (dBμV/m)	Limit (dBuV/m)	Margin (dB)	Detector	Comment
Low Channel (802.11a/ 5180 MHz)										
3252.91	44.56	44.70	6.70	28.20	-9.80	34.76	68.20	-33.44	Pk	Vertical
3252.91	40.98	44.70	6.70	28.20	-9.80	31.18	54.00	-22.82	AV	Vertical
3256.45	44.15	44.70	6.70	28.20	-9.80	34.35	68.20	-33.85	Pk	Horizontal
3256.45	41.09	44.70	6.70	28.20	-9.80	31.29	54.00	-22.71	AV	Horizontal
3983.32	39.86	44.20	7.90	29.70	-6.60	33.26	74.00	-40.74	Pk	Vertical
3983.32	36.57	44.20	7.90	29.70	-6.60	29.97	54.00	-24.03	AV	Vertical
3998.66	38.67	44.20	7.90	29.70	-6.60	32.07	74.00	-41.93	Pk	Horizontal
3998.66	36.93	44.20	7.90	29.70	-6.60	30.33	54.00	-23.67	AV	Horizontal
7230.51	36.96	43.50	11.40	35.50	3.40	40.36	68.20	-27.84	Pk	Vertical
7230.51	34.88	43.50	11.40	35.50	3.40	38.28	54.00	-15.72	AV	Vertical
7222.02	37.18	43.50	11.40	35.50	3.40	40.58	68.20	-27.62	Pk	Horizontal
7222.02	33.56	43.50	11.40	35.50	3.40	36.96	54.00	-17.04	AV	Horizontal
10359.96	40.17	44.50	13.80	38.80	8.10	48.27	68.20	-19.93	Pk	Vertical
10359.96	36.95	44.50	13.80	38.80	8.10	45.05	54.00	-8.95	AV	Vertical
10360.25	39.62	44.50	13.80	38.80	8.10	47.72	68.20	-20.48	Pk	Horizontal
10360.25	35.88	44.50	13.80	38.80	8.10	43.98	54.00	-10.02	AV	Horizontal
11026.70	34.02	43.60	14.30	39.50	10.20	44.22	74.00	-29.78	Pk	Vertical
11026.70	29.81	43.60	14.30	39.50	10.20	40.01	54.00	-13.99	AV	Vertical
11021.26	33.92	43.60	14.30	39.50	10.20	44.12	74.00	-29.88	Pk	Horizontal
11021.26	30.26	43.60	14.30	39.50	10.20	40.46	54.00	-13.54	AV	Horizontal
13295.09	31.81	42.60	15.90	38.90	12.20	44.01	74.00	-29.99	Pk	Vertical
13295.09	28.90	42.60	15.90	38.90	12.20	41.10	54.00	-12.90	AV	Vertical
13283.27	32.50	42.60	15.90	38.90	12.20	44.70	74.00	-29.30	Pk	Horizontal
13283.27	29.60	42.60	15.90	38.90	12.20	41.80	54.00	-12.20	AV	Horizontal
Mid Channel (802.11a/ 5200 MHz)										
3259.30	44.31	44.70	6.70	28.20	-9.80	34.51	68.20	-33.69	Pk	Vertical
3259.30	42.22	44.70	6.70	28.20	-9.80	32.42	54.00	-21.58	AV	Vertical
3263.88	45.20	44.70	6.70	28.20	-9.80	35.40	74.00	-38.60	Pk	Horizontal
3263.88	41.70	44.70	6.70	28.20	-9.80	31.90	54.00	-22.10	AV	Horizontal
3982.88	39.48	44.20	7.90	29.70	-6.60	32.88	74.00	-41.12	Pk	Vertical
3982.88	37.05	44.20	7.90	29.70	-6.60	30.45	54.00	-23.55	AV	Vertical
3991.81	38.83	44.20	7.90	29.70	-6.60	32.23	74.00	-41.77	Pk	Horizontal
3991.81	36.97	44.20	7.90	29.70	-6.60	30.37	54.00	-23.63	AV	Horizontal
7231.79	37.28	43.50	11.40	35.50	3.40	40.68	68.20	-27.52	Pk	Vertical
7231.79	34.82	43.50	11.40	35.50	3.40	38.22	54.00	-15.78	AV	Vertical
7234.81	36.80	43.50	11.40	35.50	3.40	40.20	68.20	-28.00	Pk	Horizontal
7234.81	33.62	43.50	11.40	35.50	3.40	37.02	54.00	-16.98	AV	Horizontal
10400.31	39.06	44.50	13.80	38.80	8.10	47.16	68.20	-21.04	Pk	Vertical
10400.31	36.02	44.50	13.80	38.80	8.10	44.12	54.00	-9.88	AV	Vertical
10400.19	40.14	44.50	13.80	38.80	8.10	48.24	68.20	-19.96	Pk	Horizontal
10400.19	35.94	44.50	13.80	38.80	8.10	44.04	54.00	-9.96	AV	Horizontal
11028.76	32.93	43.60	14.30	39.50	10.20	43.13	74.00	-30.87	Pk	Vertical
11028.76	30.33	43.60	14.30	39.50	10.20	40.53	54.00	-13.47	AV	Vertical
11023.40	32.74	43.60	14.30	39.50	10.20	42.94	74.00	-31.06	Pk	Horizontal
11023.40	30.63	43.60	14.30	39.50	10.20	40.83	54.00	-13.17	AV	Horizontal
13291.16	32.94	42.60	15.90	38.90	12.20	45.14	74.00	-28.86	Pk	Vertical
13291.16	29.00	42.60	15.90	38.90	12.20	41.20	54.00	-12.80	AV	Vertical
13287.28	32.49	42.60	15.90	38.90	12.20	44.69	74.00	-29.31	Pk	Horizontal
13287.28	28.75	42.60	15.90	38.90	12.20	40.95	54.00	-13.05	AV	Horizontal



High Channel (802.11a/ 5240 MHz)										
3248.47	43.93	44.70	6.70	28.20	-9.80	34.13	68.20	-34.07	Pk	Vertical
3248.47	41.65	44.70	6.70	28.20	-9.80	31.85	54.00	-22.15	AV	Vertical
3262.43	45.07	44.70	6.70	28.20	-9.80	35.27	74.00	-38.73	Pk	Horizontal
3262.43	41.16	44.70	6.70	28.20	-9.80	31.36	54.00	-22.64	AV	Horizontal
3999.86	38.97	44.20	7.90	29.70	-6.60	32.37	74.00	-41.63	Pk	Vertical
3999.86	36.83	44.20	7.90	29.70	-6.60	30.23	54.00	-23.77	AV	Vertical
3996.42	39.08	44.20	7.90	29.70	-6.60	32.48	74.00	-41.52	Pk	Horizontal
3996.42	35.92	44.20	7.90	29.70	-6.60	29.32	54.00	-24.68	AV	Horizontal
7227.37	37.15	43.50	11.40	35.50	3.40	40.55	68.20	-27.65	Pk	Vertical
7227.37	33.89	43.50	11.40	35.50	3.40	37.29	54.00	-16.71	AV	Vertical
7230.30	37.43	43.50	11.40	35.50	3.40	40.83	68.20	-27.37	Pk	Horizontal
7230.30	33.50	43.50	11.40	35.50	3.40	36.90	54.00	-17.10	AV	Horizontal
10480.18	39.85	44.50	13.80	38.80	8.10	47.95	68.20	-20.25	Pk	Vertical
10480.18	36.95	44.50	13.80	38.80	8.10	45.05	54.00	-8.95	AV	Vertical
10480.00	39.14	44.50	13.80	38.80	8.10	47.24	68.20	-20.96	Pk	Horizontal
10480.00	36.84	44.50	13.80	38.80	8.10	44.94	54.00	-9.06	AV	Horizontal
11020.69	32.91	43.60	14.30	39.50	10.20	43.11	74.00	-30.89	Pk	Vertical
11020.69	31.15	43.60	14.30	39.50	10.20	41.35	54.00	-12.65	AV	Vertical
11032.49	32.93	43.60	14.30	39.50	10.20	43.13	74.00	-30.87	Pk	Horizontal
11032.49	30.72	43.60	14.30	39.50	10.20	40.92	54.00	-13.08	AV	Horizontal
13290.61	32.25	42.60	15.90	38.90	12.20	44.45	74.00	-29.55	Pk	Vertical
13290.61	29.81	42.60	15.90	38.90	12.20	42.01	54.00	-11.99	AV	Vertical
13292.37	32.33	42.60	15.90	38.90	12.20	44.53	74.00	-29.47	Pk	Horizontal

Remark:

1. Factor = Antenna Factor + Cable Loss – Pre-amplifier.
2. Scan with 802.11a, 802.11n (HT-20), 802.11ac (VHT-20), 802.11ac (VHT-40), 802.11ac (VHT-80) the worst case is 802.11a.
3. The frequency emission of peak points that did not show above the forms are at least 20dB below the limit, the frequency emission is mainly from the environment noise.



U-NII-2A 5250-5350MHz

Low Channel (802.11ac40/ 5270 MHz)										
3264.26	44.83	44.70	6.70	28.20	-9.80	35.03	74.00	-38.97	Pk	Vertical
3264.26	41.26	44.70	6.70	28.20	-9.80	31.46	54.00	-22.54	AV	Vertical
3247.08	43.96	44.70	6.70	28.20	-9.80	34.16	68.20	-34.04	Pk	Horizontal
3247.08	41.66	44.70	6.70	28.20	-9.80	31.86	54.00	-22.14	AV	Horizontal
3990.51	39.27	44.20	7.90	29.70	-6.60	32.67	74.00	-41.33	Pk	Vertical
3990.51	36.36	44.20	7.90	29.70	-6.60	29.76	54.00	-24.24	AV	Vertical
3987.75	39.70	44.20	7.90	29.70	-6.60	33.10	74.00	-40.90	Pk	Horizontal
3987.75	36.62	44.20	7.90	29.70	-6.60	30.02	54.00	-23.98	AV	Horizontal
7227.63	37.82	43.50	11.40	35.50	3.40	41.22	68.20	-26.98	Pk	Vertical
7227.63	33.86	43.50	11.40	35.50	3.40	37.26	54.00	-16.74	AV	Vertical
7231.57	37.43	43.50	11.40	35.50	3.40	40.83	68.20	-27.37	Pk	Horizontal
7231.57	34.66	43.50	11.40	35.50	3.40	38.06	54.00	-15.94	AV	Horizontal
10520.27	39.33	44.50	13.90	38.80	8.20	47.53	68.20	-20.67	Pk	Vertical
10520.27	35.70	44.50	13.90	38.80	8.20	43.90	54.00	-10.10	AV	Vertical
10520.01	38.92	44.50	13.90	38.80	8.20	47.12	68.20	-21.08	Pk	Horizontal
10520.01	36.78	44.50	13.90	38.80	8.20	44.98	54.00	-9.02	AV	Horizontal
11017.01	32.88	43.60	14.30	39.50	10.20	43.08	74.00	-30.92	Pk	Vertical
11017.01	30.80	43.60	14.30	39.50	10.20	41.00	54.00	-13.00	AV	Vertical
11017.97	33.93	43.60	14.30	39.50	10.20	44.13	74.00	-29.87	Pk	Horizontal
11017.97	30.26	43.60	14.30	39.50	10.20	40.46	54.00	-13.54	AV	Horizontal
13294.85	32.23	42.60	15.90	38.90	12.20	44.43	74.00	-29.57	Pk	Vertical
13294.85	29.37	42.60	15.90	38.90	12.20	41.57	54.00	-12.43	AV	Vertical
13299.48	32.31	42.60	15.90	38.90	12.20	44.51	74.00	-29.49	Pk	Horizontal
13299.48	28.66	42.60	15.90	38.90	12.20	40.86	54.00	-13.14	AV	Horizontal
High Channel (802.11ac40/ 5310 MHz)										
3251.88	44.65	44.70	6.70	28.20	-9.80	34.85	68.20	-33.35	Pk	Vertical
3251.88	41.05	44.70	6.70	28.20	-9.80	31.25	54.00	-22.75	AV	Vertical
3248.57	45.23	44.70	6.70	28.20	-9.80	35.43	68.20	-32.77	Pk	Horizontal
3248.57	41.07	44.70	6.70	28.20	-9.80	31.27	54.00	-22.73	AV	Horizontal
3988.42	39.70	44.20	7.90	29.70	-6.60	33.10	74.00	-40.90	Pk	Vertical
3988.42	37.01	44.20	7.90	29.70	-6.60	30.41	54.00	-23.59	AV	Vertical
3990.11	39.08	44.20	7.90	29.70	-6.60	32.48	74.00	-41.52	Pk	Horizontal
3990.11	35.82	44.20	7.90	29.70	-6.60	29.22	54.00	-24.78	AV	Horizontal
7226.52	36.71	43.50	11.40	35.50	3.40	40.11	68.20	-28.09	Pk	Vertical
7226.52	33.63	43.50	11.40	35.50	3.40	37.03	54.00	-16.97	AV	Vertical
7233.53	36.76	43.50	11.40	35.50	3.40	40.16	68.20	-28.04	Pk	Horizontal
7233.53	33.53	43.50	11.40	35.50	3.40	36.93	54.00	-17.07	AV	Horizontal
10640.17	39.02	44.50	13.80	38.80	8.10	47.12	74.00	-26.88	Pk	Vertical
10640.17	36.66	44.50	13.80	38.80	8.10	44.76	54.00	-9.24	AV	Vertical
10640.01	39.78	44.50	13.80	38.80	8.10	47.88	74.00	-26.12	Pk	Horizontal
10640.01	36.63	44.50	13.80	38.80	8.10	44.73	54.00	-9.27	AV	Horizontal
11031.00	33.99	43.60	14.30	39.50	10.20	44.19	74.00	-29.81	Pk	Vertical
11031.00	31.17	43.60	14.30	39.50	10.20	41.37	54.00	-12.63	AV	Vertical
11022.59	32.69	43.60	14.30	39.50	10.20	42.89	74.00	-31.11	Pk	Horizontal
11022.59	30.69	43.60	14.30	39.50	10.20	40.89	54.00	-13.11	AV	Horizontal
13293.90	32.38	42.70	18.00	37.10	12.40	44.78	74.00	-29.22	Pk	Vertical
13293.90	29.80	42.70	18.00	37.10	12.40	42.20	54.00	-11.80	AV	Vertical
13291.14	32.15	42.70	18.00	37.10	12.40	44.55	74.00	-29.45	Pk	Horizontal
13291.14	29.20	42.70	18.00	37.10	12.40	41.60	54.00	-12.40	AV	Horizontal



U-NII-2C 5470-5725MHz

Band III(5.47-5.725) GHz										
Frequency (MHz)	Reading	Amplifier	Loss	Antenna Factor	Orrected Factor	Emission Level	Limit (dBuV/m)	Margin	Detector	Comment
	(dBuV)	(dB)	(dB)	(dB/m)	(dB)	(dBμV/m)		(dB)		
Low Channel (802.11ac40/ 5510 MHz)										
3249.17	43.85	44.70	6.70	28.20	-9.80	34.05	68.20	-34.15	Pk	Vertical
3249.17	42.00	44.70	6.70	28.20	-9.80	32.20	54.00	-21.80	AV	Vertical
3260.47	43.96	44.70	6.70	28.20	-9.80	34.16	74.00	-39.84	Pk	Horizontal
3260.47	41.83	44.70	6.70	28.20	-9.80	32.03	54.00	-21.97	AV	Horizontal
3992.22	39.22	44.20	7.90	29.70	-6.60	32.62	74.00	-41.38	Pk	Vertical
3992.22	36.83	44.20	7.90	29.70	-6.60	30.23	54.00	-23.77	AV	Vertical
3986.56	38.70	44.20	7.90	29.70	-6.60	32.10	74.00	-41.90	Pk	Horizontal
3986.56	36.32	44.20	7.90	29.70	-6.60	29.72	54.00	-24.28	AV	Horizontal
7232.67	36.52	43.50	11.40	35.50	3.40	39.92	68.20	-28.28	Pk	Vertical
7232.67	34.23	43.50	11.40	35.50	3.40	37.63	54.00	-16.37	AV	Vertical
7218.60	37.85	43.50	11.40	35.50	3.40	41.25	68.20	-26.95	Pk	Horizontal
7218.60	33.84	43.50	11.40	35.50	3.40	37.24	54.00	-16.76	AV	Horizontal
10349.28	38.70	44.50	13.80	38.80	8.10	46.80	68.20	-21.40	Pk	Vertical
10349.28	36.20	44.50	13.80	38.80	8.10	44.30	54.00	-9.70	AV	Vertical
10340.76	38.75	44.50	13.80	38.80	8.10	46.85	68.20	-21.35	Pk	Horizontal
10340.76	36.27	44.50	13.80	38.80	8.10	44.37	54.00	-9.63	AV	Horizontal
11000.23	33.97	43.60	14.30	39.50	10.20	44.17	74.00	-29.83	Pk	Vertical
11000.23	29.91	43.60	14.30	39.50	10.20	40.11	54.00	-13.89	AV	Vertical
11000.13	32.78	43.60	14.30	39.50	10.20	42.98	74.00	-31.02	Pk	Horizontal
11000.13	29.82	43.60	14.30	39.50	10.20	40.02	54.00	-13.98	AV	Horizontal
13288.21	32.21	42.60	15.90	38.90	12.20	44.41	74.00	-29.59	Pk	Vertical
13288.21	29.41	42.60	15.90	38.90	12.20	41.61	54.00	-12.39	AV	Vertical
13293.61	32.70	42.60	15.90	38.90	12.20	44.90	74.00	-29.10	Pk	Horizontal
13293.61	29.94	42.60	15.90	38.90	12.20	42.14	54.00	-11.86	AV	Horizontal
Mid Channel (802.11ac40/ 5550 MHz)										
3251.47	44.45	44.70	6.70	28.20	-9.80	34.65	68.20	-33.55	Pk	Vertical
3251.47	41.58	44.70	6.70	28.20	-9.80	31.78	54.00	-22.22	AV	Vertical
3255.21	44.58	44.70	6.70	28.20	-9.80	34.78	68.20	-33.42	Pk	Horizontal
3255.21	41.98	44.70	6.70	28.20	-9.80	32.18	54.00	-21.82	AV	Horizontal
3991.03	38.96	44.20	7.90	29.70	-6.60	32.36	74.00	-41.64	Pk	Vertical
3991.03	35.95	44.20	7.90	29.70	-6.60	29.35	54.00	-24.65	AV	Vertical
3981.49	39.07	44.20	7.90	29.70	-6.60	32.47	74.00	-41.53	Pk	Horizontal
3981.49	36.03	44.20	7.90	29.70	-6.60	29.43	54.00	-24.57	AV	Horizontal
7221.47	36.94	43.50	11.40	35.50	3.40	40.34	68.20	-27.86	Pk	Vertical
7221.47	33.96	43.50	11.40	35.50	3.40	37.36	54.00	-16.64	AV	Vertical
7217.82	37.35	43.50	11.40	35.50	3.40	40.75	68.20	-27.45	Pk	Horizontal
7217.82	33.59	43.50	11.40	35.50	3.40	36.99	54.00	-17.01	AV	Horizontal
10393.71	39.04	44.50	13.80	38.80	8.10	47.14	68.20	-21.06	Pk	Vertical
10393.71	36.08	44.50	13.80	38.80	8.10	44.18	54.00	-9.82	AV	Vertical
10392.31	39.97	44.50	13.80	38.80	8.10	48.07	68.20	-20.13	Pk	Horizontal
10392.31	36.85	44.50	13.80	38.80	8.10	44.95	54.00	-9.05	AV	Horizontal
11160.11	34.00	43.60	14.30	39.50	10.20	44.20	74.00	-29.80	Pk	Vertical
11160.11	29.71	43.60	14.30	39.50	10.20	39.91	54.00	-14.09	AV	Vertical
11160.27	33.95	43.60	14.30	39.50	10.20	44.15	74.00	-29.85	Pk	Horizontal
11160.27	31.14	43.60	14.30	39.50	10.20	41.34	54.00	-12.66	AV	Horizontal
13288.37	32.03	42.60	15.90	38.90	12.20	44.23	74.00	-29.77	Pk	Vertical
13288.37	29.48	42.60	15.90	38.90	12.20	41.68	54.00	-12.32	AV	Vertical
13299.15	31.72	42.60	15.90	38.90	12.20	43.92	74.00	-30.08	Pk	Horizontal
13299.15	29.11	42.60	15.90	38.90	12.20	41.31	54.00	-12.69	AV	Horizontal



High Channel (802.11ac40/ 5670 MHz)										
3252.76	44.44	44.70	6.70	28.20	-9.80	34.64	68.20	-33.56	Pk	Vertical
3252.76	41.38	44.70	6.70	28.20	-9.80	31.58	54.00	-22.42	AV	Vertical
3256.77	44.80	44.70	6.70	28.20	-9.80	35.00	68.20	-33.20	Pk	Horizontal
3256.77	41.30	44.70	6.70	28.20	-9.80	31.50	54.00	-22.50	AV	Horizontal
3997.20	38.72	44.20	7.90	29.70	-6.60	32.12	74.00	-41.88	Pk	Vertical
3997.20	36.72	44.20	7.90	29.70	-6.60	30.12	54.00	-23.88	AV	Vertical
3983.99	39.43	44.20	7.90	29.70	-6.60	32.83	74.00	-41.17	Pk	Horizontal
3983.99	37.02	44.20	7.90	29.70	-6.60	30.42	54.00	-23.58	AV	Horizontal
7224.64	36.68	43.50	11.40	35.50	3.40	40.08	68.20	-28.12	Pk	Vertical
7224.64	33.44	43.50	11.40	35.50	3.40	36.84	54.00	-17.16	AV	Vertical
7226.60	37.80	43.50	11.40	35.50	3.40	41.20	68.20	-27.00	Pk	Horizontal
7226.60	33.46	43.50	11.40	35.50	3.40	36.86	54.00	-17.14	AV	Horizontal
10474.17	39.21	44.50	13.80	38.80	8.10	47.31	68.20	-20.89	Pk	Vertical
10474.17	36.88	44.50	13.80	38.80	8.10	44.98	54.00	-9.02	AV	Vertical
10479.43	39.27	44.50	13.80	38.80	8.10	47.37	68.20	-20.83	Pk	Horizontal
10479.43	36.88	44.50	13.80	38.80	8.10	44.98	54.00	-9.02	AV	Horizontal
11400.30	33.07	43.60	14.30	39.50	10.20	43.27	74.00	-30.73	Pk	Vertical
11400.30	29.69	43.60	14.30	39.50	10.20	39.89	54.00	-14.11	AV	Vertical
11400.09	34.03	43.60	14.30	39.50	10.20	44.23	74.00	-29.77	Pk	Horizontal
11400.09	30.43	43.60	14.30	39.50	10.20	40.63	54.00	-13.37	AV	Horizontal
13281.82	32.21	42.60	15.90	38.90	12.20	44.41	74.00	-29.59	Pk	Vertical
13281.82	28.75	42.60	15.90	38.90	12.20	40.95	54.00	-13.05	AV	Vertical
13299.58	32.54	42.60	15.90	38.90	12.20	44.74	74.00	-29.26	Pk	Horizontal
13299.58	28.95	42.60	15.90	38.90	12.20	41.15	54.00	-12.85	AV	Horizontal

Remark:

1. Factor = Antenna Factor + Cable Loss – Pre-amplifier.
2. Scan with 802.11a, 802.11n (HT-20), 802.11ac (VHT-20), 802.11ac (VHT-40), 802.11ac (VHT-80) the worst case is 802.11ac (VHT-40).
3. The frequency emission of peak points that did not show above the forms are at least 20dB below the limit, the frequency emission is mainly from the environment noise.



U-NII-3 (5.725-5.850) GHz

Band IV(5.725-5.895) GHz										
Frequency (MHz)	Reading	Amplifier	Loss	Antenna Factor	Orrected Factor	Emission Level	Limit (dBuV/m)	Margin	Detector	Comment
	(dBuV)	(dB)	(dB)	(dB/m)	(dB)	(dBuV/m)		(dB)		
Mid Channel (802.11ac80/ 5775 MHz)										
3258.97	44.36	44.70	6.70	28.20	-9.80	34.56	68.20	-33.64	Pk	Vertical
3258.97	41.69	44.70	6.70	28.20	-9.80	31.89	54.00	-22.11	AV	Vertical
3257.24	44.44	44.70	6.70	28.20	-9.80	34.64	68.20	-33.56	Pk	Horizontal
3257.24	41.57	44.70	6.70	28.20	-9.80	31.77	54.00	-22.23	AV	Horizontal
3994.64	39.25	44.20	7.90	29.70	-6.60	32.65	74.00	-41.35	Pk	Vertical
3994.64	36.07	44.20	7.90	29.70	-6.60	29.47	54.00	-24.53	AV	Vertical
3988.59	40.01	44.20	7.90	29.70	-6.60	33.41	74.00	-40.59	Pk	Horizontal
3988.59	36.21	44.20	7.90	29.70	-6.60	29.61	54.00	-24.39	AV	Horizontal
7227.62	36.75	43.50	11.40	35.50	3.40	40.15	68.20	-28.05	Pk	Vertical
7227.62	34.12	43.50	11.40	35.50	3.40	37.52	54.00	-16.48	AV	Vertical
7226.29	37.64	43.50	11.40	35.50	3.40	41.04	68.20	-27.16	Pk	Horizontal
7226.29	34.72	43.50	11.40	35.50	3.40	38.12	54.00	-15.88	AV	Horizontal
10597.39	38.99	44.50	13.80	38.80	8.10	47.09	68.20	-21.11	Pk	Vertical
10597.39	36.76	44.50	13.80	38.80	8.10	44.86	54.00	-9.14	AV	Vertical
10589.34	39.58	44.50	13.80	38.80	8.10	47.68	68.20	-20.52	Pk	Horizontal
10589.34	35.67	44.50	13.80	38.80	8.10	43.77	54.00	-10.23	AV	Horizontal
11570.41	33.78	43.60	14.30	39.50	10.20	43.98	74.00	-30.02	Pk	Vertical
11570.41	29.96	43.60	14.30	39.50	10.20	40.16	54.00	-13.84	AV	Vertical
11570.37	33.47	43.60	14.30	39.50	10.20	43.67	74.00	-30.33	Pk	Horizontal
11570.37	29.90	43.60	14.30	39.50	10.20	40.10	54.00	-13.90	AV	Horizontal
13288.70	32.58	42.60	15.90	38.90	12.20	44.78	74.00	-29.22	Pk	Vertical
13288.70	28.94	42.60	15.90	38.90	12.20	41.14	54.00	-12.86	AV	Vertical
13297.55	31.70	42.60	15.90	38.90	12.20	43.90	74.00	-30.10	Pk	Horizontal
13297.55	29.94	42.60	15.90	38.90	12.20	42.14	54.00	-11.86	AV	Horizontal

Remark:

1. Factor = Antenna Factor + Cable Loss – Pre-amplifier.

2. Scan with 802.11a,802.11n (HT-20), 802.11ac (VHT-20),802.11ac (VHT-40), 802.11ac (VHT-80) the worst case is 802.11ac (VHT-80).



MOX 2

U-NII-1 5150-5250MHz

Band I(5.15-5.25) GHz										
Frequency (MHz)	Reading (dBuV)	Amplifier (dB)	Loss (dB)	Antenna Factor (dB/m)	Orrected Factor (dB)	Emission Level (dBµV/m)	Limit (dBuV/m)	Margin (dB)	Detector	Comment
Low Channel (802.11a/ 5180 MHz)										
3251.00	44.74	44.70	6.70	28.20	-9.80	34.94	68.20	-33.26	Pk	Vertical
3251.00	41.54	44.70	6.70	28.20	-9.80	31.74	54.00	-22.26	AV	Vertical
3259.61	44.95	44.70	6.70	28.20	-9.80	35.15	68.20	-33.05	Pk	Horizontal
3259.61	40.76	44.70	6.70	28.20	-9.80	30.96	54.00	-23.04	AV	Horizontal
3986.95	39.52	44.20	7.90	29.70	-6.60	32.92	74.00	-41.08	Pk	Vertical
3986.95	36.97	44.20	7.90	29.70	-6.60	30.37	54.00	-23.63	AV	Vertical
3982.80	39.42	44.20	7.90	29.70	-6.60	32.82	74.00	-41.18	Pk	Horizontal
3982.80	36.46	44.20	7.90	29.70	-6.60	29.86	54.00	-24.14	AV	Horizontal
7230.51	36.62	43.50	11.40	35.50	3.40	40.02	68.20	-28.18	Pk	Vertical
7230.51	33.99	43.50	11.40	35.50	3.40	37.39	54.00	-16.61	AV	Vertical
7222.65	36.52	43.50	11.40	35.50	3.40	39.92	68.20	-28.28	Pk	Horizontal
7222.65	34.24	43.50	11.40	35.50	3.40	37.64	54.00	-16.36	AV	Horizontal
10360.32	39.05	44.50	13.80	38.80	8.10	47.15	68.20	-21.05	Pk	Vertical
10360.32	36.91	44.50	13.80	38.80	8.10	45.01	54.00	-8.99	AV	Vertical
10360.16	39.06	44.50	13.80	38.80	8.10	47.16	68.20	-21.04	Pk	Horizontal
10360.16	35.98	44.50	13.80	38.80	8.10	44.08	54.00	-9.92	AV	Horizontal
11033.22	33.93	43.60	14.30	39.50	10.20	44.13	74.00	-29.87	Pk	Vertical
11033.22	30.59	43.60	14.30	39.50	10.20	40.79	54.00	-13.21	AV	Vertical
11028.28	33.46	43.60	14.30	39.50	10.20	43.66	74.00	-30.34	Pk	Horizontal
11028.28	30.49	43.60	14.30	39.50	10.20	40.69	54.00	-13.31	AV	Horizontal
13294.83	32.93	42.60	15.90	38.90	12.20	45.13	74.00	-28.87	Pk	Vertical
13294.83	29.74	42.60	15.90	38.90	12.20	41.94	54.00	-12.06	AV	Vertical
13291.24	32.92	42.60	15.90	38.90	12.20	45.12	74.00	-28.88	Pk	Horizontal
13291.24	29.08	42.60	15.90	38.90	12.20	41.28	54.00	-12.72	AV	Horizontal
Mid Channel (802.11a/ 5200 MHz)										
3257.31	44.87	44.70	6.70	28.20	-9.80	35.07	68.20	-33.13	Pk	Vertical
3257.31	40.75	44.70	6.70	28.20	-9.80	30.95	54.00	-23.05	AV	Vertical
3245.37	43.80	44.70	6.70	28.20	-9.80	34.00	68.20	-34.20	Pk	Horizontal
3245.37	41.55	44.70	6.70	28.20	-9.80	31.75	54.00	-22.25	AV	Horizontal
3987.27	40.07	44.20	7.90	29.70	-6.60	33.47	74.00	-40.53	Pk	Vertical
3987.27	35.67	44.20	7.90	29.70	-6.60	29.07	54.00	-24.93	AV	Vertical
3999.34	39.20	44.20	7.90	29.70	-6.60	32.60	74.00	-41.40	Pk	Horizontal
3999.34	35.87	44.20	7.90	29.70	-6.60	29.27	54.00	-24.73	AV	Horizontal
7221.40	37.75	43.50	11.40	35.50	3.40	41.15	68.20	-27.05	Pk	Vertical
7221.40	34.01	43.50	11.40	35.50	3.40	37.41	54.00	-16.59	AV	Vertical
7233.36	37.10	43.50	11.40	35.50	3.40	40.50	68.20	-27.70	Pk	Horizontal
7233.36	34.17	43.50	11.40	35.50	3.40	37.57	54.00	-16.43	AV	Horizontal
10400.09	38.81	44.50	13.80	38.80	8.10	46.91	68.20	-21.29	Pk	Vertical
10400.09	35.91	44.50	13.80	38.80	8.10	44.01	54.00	-9.99	AV	Vertical
10400.22	39.80	44.50	13.80	38.80	8.10	47.90	68.20	-20.30	Pk	Horizontal
10400.22	35.81	44.50	13.80	38.80	8.10	43.91	54.00	-10.09	AV	Horizontal
11035.98	33.94	43.60	14.30	39.50	10.20	44.14	74.00	-29.86	Pk	Vertical
11035.98	30.57	43.60	14.30	39.50	10.20	40.77	54.00	-13.23	AV	Vertical
11025.88	33.50	43.60	14.30	39.50	10.20	43.70	74.00	-30.30	Pk	Horizontal
11025.88	30.35	43.60	14.30	39.50	10.20	40.55	54.00	-13.45	AV	Horizontal
13284.54	33.01	42.60	15.90	38.90	12.20	45.21	74.00	-28.79	Pk	Vertical
13284.54	28.79	42.60	15.90	38.90	12.20	40.99	54.00	-13.01	AV	Vertical
13286.31	32.56	42.60	15.90	38.90	12.20	44.76	74.00	-29.24	Pk	Horizontal
13286.31	29.46	42.60	15.90	38.90	12.20	41.66	54.00	-12.34	AV	Horizontal



High Channel (802.11a/ 5240 MHz)										
3246.36	43.81	44.70	6.70	28.20	-9.80	34.01	68.20	-34.19	Pk	Vertical
3246.36	41.19	44.70	6.70	28.20	-9.80	31.39	54.00	-22.61	AV	Vertical
3262.05	44.94	44.70	6.70	28.20	-9.80	35.14	74.00	-38.86	Pk	Horizontal
3262.05	41.36	44.70	6.70	28.20	-9.80	31.56	54.00	-22.44	AV	Horizontal
3989.71	39.50	44.20	7.90	29.70	-6.60	32.90	74.00	-41.10	Pk	Vertical
3989.71	36.75	44.20	7.90	29.70	-6.60	30.15	54.00	-23.85	AV	Vertical
3982.69	39.00	44.20	7.90	29.70	-6.60	32.40	74.00	-41.60	Pk	Horizontal
3982.69	36.10	44.20	7.90	29.70	-6.60	29.50	54.00	-24.50	AV	Horizontal
7224.90	37.31	43.50	11.40	35.50	3.40	40.71	68.20	-27.49	Pk	Vertical
7224.90	33.83	43.50	11.40	35.50	3.40	37.23	54.00	-16.77	AV	Vertical
7223.77	37.20	43.50	11.40	35.50	3.40	40.60	68.20	-27.60	Pk	Horizontal
7223.77	33.68	43.50	11.40	35.50	3.40	37.08	54.00	-16.92	AV	Horizontal
10479.97	39.01	44.50	13.80	38.80	8.10	47.11	68.20	-21.09	Pk	Vertical
10479.97	35.88	44.50	13.80	38.80	8.10	43.98	54.00	-10.02	AV	Vertical
10480.38	39.63	44.50	13.80	38.80	8.10	47.73	68.20	-20.47	Pk	Horizontal
10480.38	36.78	44.50	13.80	38.80	8.10	44.88	54.00	-9.12	AV	Horizontal
11024.82	33.10	43.60	14.30	39.50	10.20	43.30	74.00	-30.70	Pk	Vertical
11024.82	30.99	43.60	14.30	39.50	10.20	41.19	54.00	-12.81	AV	Vertical
11029.95	34.02	43.60	14.30	39.50	10.20	44.22	74.00	-29.78	Pk	Horizontal
11029.95	30.68	43.60	14.30	39.50	10.20	40.88	54.00	-13.12	AV	Horizontal
13295.34	31.58	42.60	15.90	38.90	12.20	43.78	74.00	-30.22	Pk	Vertical
13295.34	29.28	42.60	15.90	38.90	12.20	41.48	54.00	-12.52	AV	Vertical
13292.93	31.70	42.60	15.90	38.90	12.20	43.90	74.00	-30.10	Pk	Horizontal
13292.93	29.34	42.60	15.90	38.90	12.20	41.54	54.00	-12.46	AV	Horizontal

Remark:

1. Factor = Antenna Factor + Cable Loss – Pre-amplifier.
2. Scan with 802.11a, 802.11n (HT-20), 802.11ac (VHT-20), 802.11ac (VHT-40), 802.11ac (VHT-80) the worst case is 802.11a.
3. The frequency emission of peak points that did not show above the forms are at least 20dB below the limit, the frequency emission is mainly from the environment noise.



U-NII-2A 5250-5350MHz

Band II(5.25-5.35) GHz										
Frequency (MHz)	Reading	Amplifier	Loss	Antenna Factor	Orrected Factor	Emission Level	Limit (dBuV/m)	Margin	Detector	Comment
	(dBuV)	(dB)	(dB)	(dB/m)	(dB)	(dBuV/m)		(dB)		
Low Channel (802.11ac40/ 5270 MHz)										
3258.70	44.66	44.70	6.70	28.20	-9.80	34.86	68.20	-33.34	Pk	Vertical
3258.70	42.16	44.70	6.70	28.20	-9.80	32.36	54.00	-21.64	AV	Vertical
3246.27	44.89	44.70	6.70	28.20	-9.80	35.09	68.20	-33.11	Pk	Horizontal
3246.27	41.61	44.70	6.70	28.20	-9.80	31.81	54.00	-22.19	AV	Horizontal
3997.63	39.41	44.20	7.90	29.70	-6.60	32.81	74.00	-41.19	Pk	Vertical
3997.63	36.64	44.20	7.90	29.70	-6.60	30.04	54.00	-23.96	AV	Vertical
3991.88	38.95	44.20	7.90	29.70	-6.60	32.35	74.00	-41.65	Pk	Horizontal
3991.88	36.59	44.20	7.90	29.70	-6.60	29.99	54.00	-24.01	AV	Horizontal
7225.97	37.58	43.50	11.40	35.50	3.40	40.98	68.20	-27.22	Pk	Vertical
7225.97	34.75	43.50	11.40	35.50	3.40	38.15	54.00	-15.85	AV	Vertical
7218.18	36.84	43.50	11.40	35.50	3.40	40.24	68.20	-27.96	Pk	Horizontal
7218.18	34.34	43.50	11.40	35.50	3.40	37.74	54.00	-16.26	AV	Horizontal
10520.00	39.95	44.50	13.90	38.80	8.20	48.15	68.20	-20.05	Pk	Vertical
10520.00	36.39	44.50	13.90	38.80	8.20	44.59	54.00	-9.41	AV	Vertical
10520.16	39.86	44.50	13.90	38.80	8.20	48.06	68.20	-20.14	Pk	Horizontal
10520.16	37.02	44.50	13.90	38.80	8.20	45.22	54.00	-8.78	AV	Horizontal
11032.37	33.09	43.60	14.30	39.50	10.20	43.29	74.00	-30.71	Pk	Vertical
11032.37	30.93	43.60	14.30	39.50	10.20	41.13	54.00	-12.87	AV	Vertical
11016.49	33.13	43.60	14.30	39.50	10.20	43.33	74.00	-30.67	Pk	Horizontal
11016.49	30.15	43.60	14.30	39.50	10.20	40.35	54.00	-13.65	AV	Horizontal
13296.80	33.01	42.60	15.90	38.90	12.20	45.21	74.00	-28.79	Pk	Vertical
13296.80	28.90	42.60	15.90	38.90	12.20	41.10	54.00	-12.90	AV	Vertical
13281.26	31.69	42.60	15.90	38.90	12.20	43.89	74.00	-30.11	Pk	Horizontal
13281.26	29.56	42.60	15.90	38.90	12.20	41.76	54.00	-12.24	AV	Horizontal
High Channel (802.11ac40/ 5310 MHz)										
3253.77	44.01	44.70	6.70	28.20	-9.80	34.21	68.20	-33.99	Pk	Vertical
3253.77	41.37	44.70	6.70	28.20	-9.80	31.57	54.00	-22.43	AV	Vertical
3254.33	45.14	44.70	6.70	28.20	-9.80	35.34	68.20	-32.86	Pk	Horizontal
3254.33	40.82	44.70	6.70	28.20	-9.80	31.02	54.00	-22.98	AV	Horizontal
3999.56	39.06	44.20	7.90	29.70	-6.60	32.46	74.00	-41.54	Pk	Vertical
3999.56	36.35	44.20	7.90	29.70	-6.60	29.75	54.00	-24.25	AV	Vertical
3983.47	39.48	44.20	7.90	29.70	-6.60	32.88	74.00	-41.12	Pk	Horizontal
3983.47	36.02	44.20	7.90	29.70	-6.60	29.42	54.00	-24.58	AV	Horizontal
7219.09	37.27	43.50	11.40	35.50	3.40	40.67	68.20	-27.53	Pk	Vertical
7219.09	33.51	43.50	11.40	35.50	3.40	36.91	54.00	-17.09	AV	Vertical
7223.39	36.72	43.50	11.40	35.50	3.40	40.12	68.20	-28.08	Pk	Horizontal
7223.39	34.52	43.50	11.40	35.50	3.40	37.92	54.00	-16.08	AV	Horizontal
10600.38	39.80	44.50	13.80	38.80	8.10	47.90	74.00	-26.10	Pk	Vertical
10600.38	35.90	44.50	13.80	38.80	8.10	44.00	54.00	-10.00	AV	Vertical
10600.04	39.46	44.50	13.80	38.80	8.10	47.56	74.00	-26.44	Pk	Horizontal
10600.04	36.00	44.50	13.80	38.80	8.10	44.10	54.00	-9.90	AV	Horizontal
11028.74	33.32	43.60	14.30	39.50	10.20	43.52	74.00	-30.48	Pk	Vertical
11028.74	30.38	43.60	14.30	39.50	10.20	40.58	54.00	-13.42	AV	Vertical
11026.21	34.18	43.60	14.30	39.50	10.20	44.38	74.00	-29.62	Pk	Horizontal
11026.21	30.07	43.60	14.30	39.50	10.20	40.27	54.00	-13.73	AV	Horizontal
13298.84	32.91	42.70	18.00	37.10	12.40	45.31	74.00	-28.69	Pk	Vertical
13298.84	29.27	42.70	18.00	37.10	12.40	41.67	54.00	-12.33	AV	Vertical
13281.66	31.96	42.70	18.00	37.10	12.40	44.36	74.00	-29.64	Pk	Horizontal
13281.66	29.14	42.70	18.00	37.10	12.40	41.54	54.00	-12.46	AV	Horizontal



U-NII-2C 5470-5725MHz

Band III(5.47-5.725) GHz										
Frequency (MHz)	Reading	Amplifier	Loss	Antenna Factor	Orrected Factor	Emission Level	Limit (dBuV/m)	Margin	Detector	Comment
	(dBuV)	(dB)	(dB)	(dB/m)	(dB)	(dBuV/m)		(dB)		
Low Channel (802.11ac40/ 5510 MHz)										
3257.73	44.74	44.70	6.70	28.20	-9.80	34.94	68.20	-33.26	Pk	Vertical
3257.73	41.66	44.70	6.70	28.20	-9.80	31.86	54.00	-22.14	AV	Vertical
3246.66	44.42	44.70	6.70	28.20	-9.80	34.62	68.20	-33.58	Pk	Horizontal
3246.66	41.45	44.70	6.70	28.20	-9.80	31.65	54.00	-22.35	AV	Horizontal
3986.87	39.03	44.20	7.90	29.70	-6.60	32.43	74.00	-41.57	Pk	Vertical
3986.87	36.69	44.20	7.90	29.70	-6.60	30.09	54.00	-23.91	AV	Vertical
3997.17	40.10	44.20	7.90	29.70	-6.60	33.50	74.00	-40.50	Pk	Horizontal
3997.17	36.93	44.20	7.90	29.70	-6.60	30.33	54.00	-23.67	AV	Horizontal
7226.51	37.83	43.50	11.40	35.50	3.40	41.23	68.20	-26.97	Pk	Vertical
7226.51	33.51	43.50	11.40	35.50	3.40	36.91	54.00	-17.09	AV	Vertical
7234.67	36.99	43.50	11.40	35.50	3.40	40.39	68.20	-27.81	Pk	Horizontal
7234.67	33.81	43.50	11.40	35.50	3.40	37.21	54.00	-16.79	AV	Horizontal
10355.59	40.09	44.50	13.80	38.80	8.10	48.19	68.20	-20.01	Pk	Vertical
10355.59	36.90	44.50	13.80	38.80	8.10	45.00	54.00	-9.00	AV	Vertical
10348.91	38.82	44.50	13.80	38.80	8.10	46.92	68.20	-21.28	Pk	Horizontal
10348.91	36.97	44.50	13.80	38.80	8.10	45.07	54.00	-8.93	AV	Horizontal
11000.37	32.71	43.60	14.30	39.50	10.20	42.91	74.00	-31.09	Pk	Vertical
11000.37	30.54	43.60	14.30	39.50	10.20	40.74	54.00	-13.26	AV	Vertical
11000.17	33.50	43.60	14.30	39.50	10.20	43.70	74.00	-30.30	Pk	Horizontal
11000.17	30.62	43.60	14.30	39.50	10.20	40.82	54.00	-13.18	AV	Horizontal
13289.07	32.12	42.60	15.90	38.90	12.20	44.32	74.00	-29.68	Pk	Vertical
13289.07	29.60	42.60	15.90	38.90	12.20	41.80	54.00	-12.20	AV	Vertical
13281.71	32.78	42.60	15.90	38.90	12.20	44.98	74.00	-29.02	Pk	Horizontal
13281.71	28.84	42.60	15.90	38.90	12.20	41.04	54.00	-12.96	AV	Horizontal
Mid Channel (802.11ac40/ 5550 MHz)										
3263.51	44.54	44.70	6.70	28.20	-9.80	34.74	74.00	-39.26	Pk	Vertical
3263.51	41.98	44.70	6.70	28.20	-9.80	32.18	54.00	-21.82	AV	Vertical
3246.14	45.17	44.70	6.70	28.20	-9.80	35.37	68.20	-32.83	Pk	Horizontal
3246.14	40.88	44.70	6.70	28.20	-9.80	31.08	54.00	-22.92	AV	Horizontal
4000.10	39.80	44.20	7.90	29.70	-6.60	33.20	74.00	-40.80	Pk	Vertical
4000.10	36.71	44.20	7.90	29.70	-6.60	30.11	54.00	-23.89	AV	Vertical
3988.22	39.64	44.20	7.90	29.70	-6.60	33.04	74.00	-40.96	Pk	Horizontal
3988.22	36.95	44.20	7.90	29.70	-6.60	30.35	54.00	-23.65	AV	Horizontal
7216.94	36.89	43.50	11.40	35.50	3.40	40.29	68.20	-27.91	Pk	Vertical
7216.94	33.51	43.50	11.40	35.50	3.40	36.91	54.00	-17.09	AV	Vertical
7222.96	36.72	43.50	11.40	35.50	3.40	40.12	68.20	-28.08	Pk	Horizontal
7222.96	34.38	43.50	11.40	35.50	3.40	37.78	54.00	-16.22	AV	Horizontal
10382.97	39.85	44.50	13.80	38.80	8.10	47.95	68.20	-20.25	Pk	Vertical
10382.97	36.16	44.50	13.80	38.80	8.10	44.26	54.00	-9.74	AV	Vertical
10381.46	39.38	44.50	13.80	38.80	8.10	47.48	68.20	-20.72	Pk	Horizontal
10381.46	36.21	44.50	13.80	38.80	8.10	44.31	54.00	-9.69	AV	Horizontal
11159.98	34.09	43.60	14.30	39.50	10.20	44.29	74.00	-29.71	Pk	Vertical
11159.98	30.28	43.60	14.30	39.50	10.20	40.48	54.00	-13.52	AV	Vertical
11160.11	33.36	43.60	14.30	39.50	10.20	43.56	74.00	-30.44	Pk	Horizontal
11160.11	30.78	43.60	14.30	39.50	10.20	40.98	54.00	-13.02	AV	Horizontal
13284.92	31.71	42.60	15.90	38.90	12.20	43.91	74.00	-30.09	Pk	Vertical
13284.92	29.26	42.60	15.90	38.90	12.20	41.46	54.00	-12.54	AV	Vertical
13285.53	32.75	42.60	15.90	38.90	12.20	44.95	74.00	-29.05	Pk	Horizontal
13285.53	29.31	42.60	15.90	38.90	12.20	41.51	54.00	-12.49	AV	Horizontal
High Channel (802.11ac40/ 5670 MHz)										
3247.65	44.16	44.70	6.70	28.20	-9.80	34.36	68.20	-33.84	Pk	Vertical
3247.65	41.32	44.70	6.70	28.20	-9.80	31.52	54.00	-22.48	AV	Vertical
3255.00	43.97	44.70	6.70	28.20	-9.80	34.17	68.20	-34.03	Pk	Horizontal



3255.00	40.82	44.70	6.70	28.20	-9.80	31.02	54.00	-22.98	AV	Horizontal
3996.35	39.04	44.20	7.90	29.70	-6.60	32.44	74.00	-41.56	Pk	Vertical
3996.35	36.88	44.20	7.90	29.70	-6.60	30.28	54.00	-23.72	AV	Vertical
3996.65	39.19	44.20	7.90	29.70	-6.60	32.59	74.00	-41.41	Pk	Horizontal
3996.65	36.22	44.20	7.90	29.70	-6.60	29.62	54.00	-24.38	AV	Horizontal
7228.23	37.32	43.50	11.40	35.50	3.40	40.72	68.20	-27.48	Pk	Vertical
7228.23	34.29	43.50	11.40	35.50	3.40	37.69	54.00	-16.31	AV	Vertical
7232.80	36.89	43.50	11.40	35.50	3.40	40.29	68.20	-27.91	Pk	Horizontal
7232.80	34.53	43.50	11.40	35.50	3.40	37.93	54.00	-16.07	AV	Horizontal
10469.67	38.76	44.50	13.80	38.80	8.10	46.86	68.20	-21.34	Pk	Vertical
10469.67	36.67	44.50	13.80	38.80	8.10	44.77	54.00	-9.23	AV	Vertical
10473.09	39.91	44.50	13.80	38.80	8.10	48.01	68.20	-20.19	Pk	Horizontal
10473.09	36.78	44.50	13.80	38.80	8.10	44.88	54.00	-9.12	AV	Horizontal
11400.37	34.15	43.60	14.30	39.50	10.20	44.35	74.00	-29.65	Pk	Vertical
11400.37	31.10	43.60	14.30	39.50	10.20	41.30	54.00	-12.70	AV	Vertical
11400.43	33.06	43.60	14.30	39.50	10.20	43.26	74.00	-30.74	Pk	Horizontal
11400.43	30.55	43.60	14.30	39.50	10.20	40.75	54.00	-13.25	AV	Horizontal
13292.02	32.46	42.60	15.90	38.90	12.20	44.66	74.00	-29.34	Pk	Vertical
13292.02	29.30	42.60	15.90	38.90	12.20	41.50	54.00	-12.50	AV	Vertical
13283.58	31.72	42.60	15.90	38.90	12.20	43.92	74.00	-30.08	Pk	Horizontal
13283.58	28.65	42.60	15.90	38.90	12.20	40.85	54.00	-13.15	AV	Horizontal

Remark:

1. Factor = Antenna Factor + Cable Loss – Pre-amplifier.
2. Scan with 802.11a, 802.11n (HT-20), 802.11ac (VHT-20), 802.11ac (VHT-40), 802.11ac (VHT-80) the worst case is 802.11ac (VHT-40).
3. The frequency emission of peak points that did not show above the forms are at least 20dB below the limit, the frequency emission is mainly from the environment noise.

**U-NII-3 (5.725-5.850) GHz**

Band IV(5.725-5.895) GHz										
Frequency (MHz)	Reading	Amplifier	Loss	Antenna Factor	Orrected Factor	Emission Level	Limit (dBuV/m)	Margin	Detector	Comment
	(dBuV)	(dB)	(dB)	(dB/m)	(dB)	(dBuV/m)		(dB)		
Mid Channel (802.11ac80/ 5775 MHz)										
3257.78	44.30	44.70	6.70	28.20	-9.80	34.50	68.20	-33.70	Pk	Vertical
3257.78	42.21	44.70	6.70	28.20	-9.80	32.41	54.00	-21.59	AV	Vertical
3246.48	45.01	44.70	6.70	28.20	-9.80	35.21	68.20	-32.99	Pk	Horizontal
3246.48	41.34	44.70	6.70	28.20	-9.80	31.54	54.00	-22.46	AV	Horizontal
3995.25	39.82	44.20	7.90	29.70	-6.60	33.22	74.00	-40.78	Pk	Vertical
3995.25	36.15	44.20	7.90	29.70	-6.60	29.55	54.00	-24.45	AV	Vertical
3989.56	39.74	44.20	7.90	29.70	-6.60	33.14	74.00	-40.86	Pk	Horizontal
3989.56	36.36	44.20	7.90	29.70	-6.60	29.76	54.00	-24.24	AV	Horizontal
7235.63	37.39	43.50	11.40	35.50	3.40	40.79	68.20	-27.41	Pk	Vertical
7235.63	34.42	43.50	11.40	35.50	3.40	37.82	54.00	-16.18	AV	Vertical
7220.71	37.14	43.50	11.40	35.50	3.40	40.54	68.20	-27.66	Pk	Horizontal
7220.71	34.24	43.50	11.40	35.50	3.40	37.64	54.00	-16.36	AV	Horizontal
10595.42	39.11	44.50	13.80	38.80	8.10	47.21	68.20	-20.99	Pk	Vertical
10595.42	35.76	44.50	13.80	38.80	8.10	43.86	54.00	-10.14	AV	Vertical
10587.39	40.14	44.50	13.80	38.80	8.10	48.24	68.20	-19.96	Pk	Horizontal
10587.39	35.79	44.50	13.80	38.80	8.10	43.89	54.00	-10.11	AV	Horizontal
11570.34	33.26	43.60	14.30	39.50	10.20	43.46	74.00	-30.54	Pk	Vertical
11570.34	30.10	43.60	14.30	39.50	10.20	40.30	54.00	-13.70	AV	Vertical
11570.32	32.94	43.60	14.30	39.50	10.20	43.14	74.00	-30.86	Pk	Horizontal
11570.32	30.06	43.60	14.30	39.50	10.20	40.26	54.00	-13.74	AV	Horizontal
13286.73	32.79	42.60	15.90	38.90	12.20	44.99	74.00	-29.01	Pk	Vertical
13286.73	28.94	42.60	15.90	38.90	12.20	41.14	54.00	-12.86	AV	Vertical
13283.58	32.23	42.60	15.90	38.90	12.20	44.43	74.00	-29.57	Pk	Horizontal
13283.58	29.29	42.60	15.90	38.90	12.20	41.49	54.00	-12.51	AV	Horizontal

Remark:

- Factor = Antenna Factor + Cable Loss – Pre-amplifier.
- Scan with 802.11a,802.11n (HT-20), 802.11ac (VHT-20),802.11ac (VHT-40), 802.11ac (VHT-80) the worst case is 802.11ac (VHT-80).

3.2.9 RESTRICTED FREQUENCY BANDS AND BAND EDGE

MOJO

U-NII-1 5150-5250MHz

802.11a20-L-H

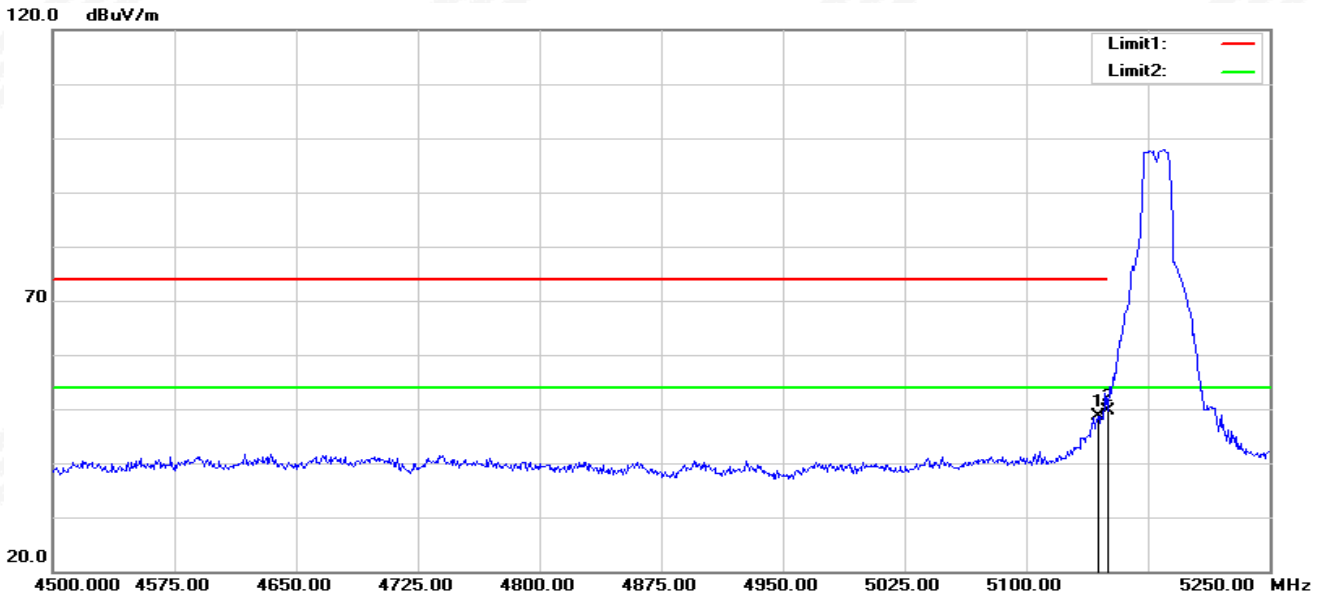

No.	Frequency (MHz)	Reading (dBuV)	Correct Factor(dB/m)	Result (dBuV/m)	Limit (dBuV/m)	Margin (dB)	Remark
1	5144.250	54.27	-5.73	48.54	74.00	-25.46	peak
2	5150.000	55.24	-5.73	49.51	74.00	-24.49	peak

802.11a20-L-V

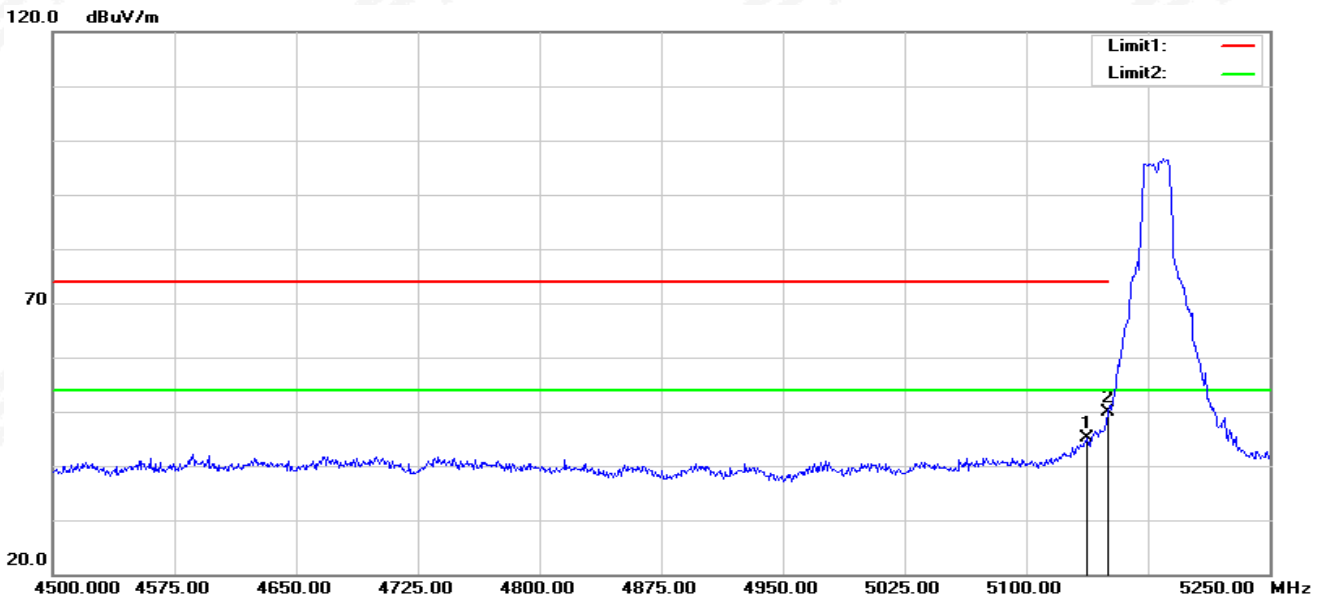

No.	Frequency (MHz)	Reading (dBuV)	Correct Factor(dB/m)	Result (dBuV/m)	Limit (dBuV/m)	Margin (dB)	Remark
1	5137.500	50.76	-5.74	45.02	74.00	-28.98	peak
2	5150.000	55.58	-5.73	49.85	74.00	-24.15	peak



802.11a20-H-H

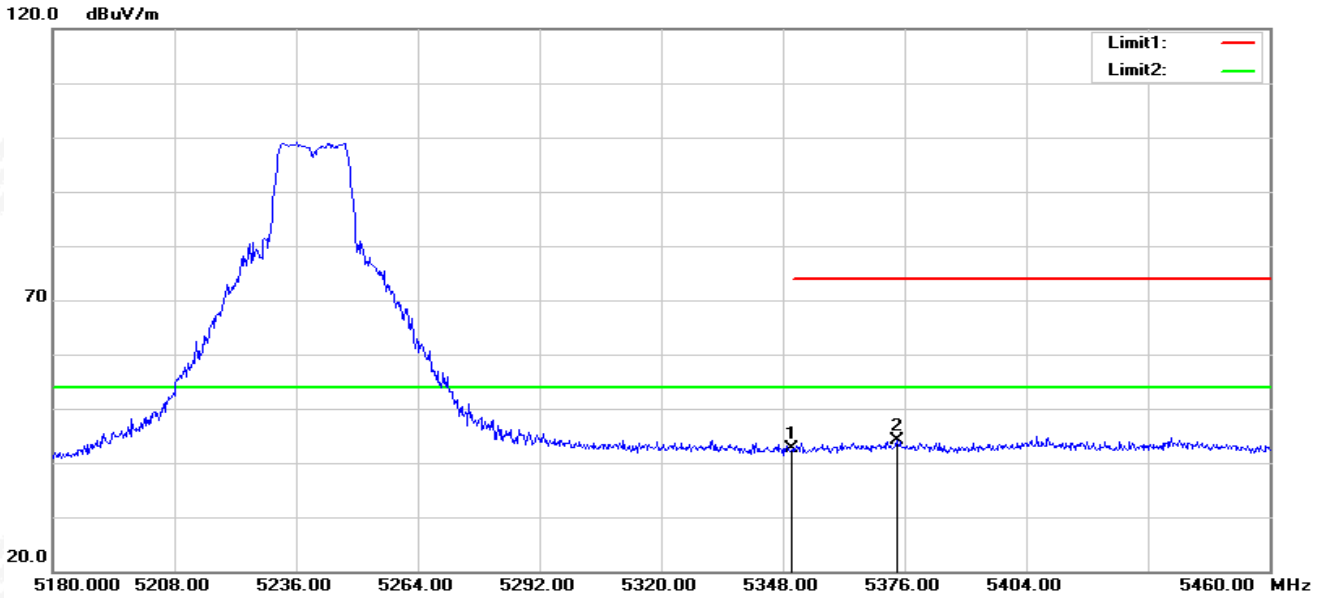

No.	Frequency (MHz)	Reading (dBuV)	Correct Factor(dB/m)	Result (dBuV/m)	Limit (dBuV/m)	Margin (dB)	Remark
1	5350.000	47.94	-5.23	42.71	74.00	-31.29	peak
2	5374.320	49.48	-5.24	44.24	74.00	-29.76	peak

802.11a20-H-V

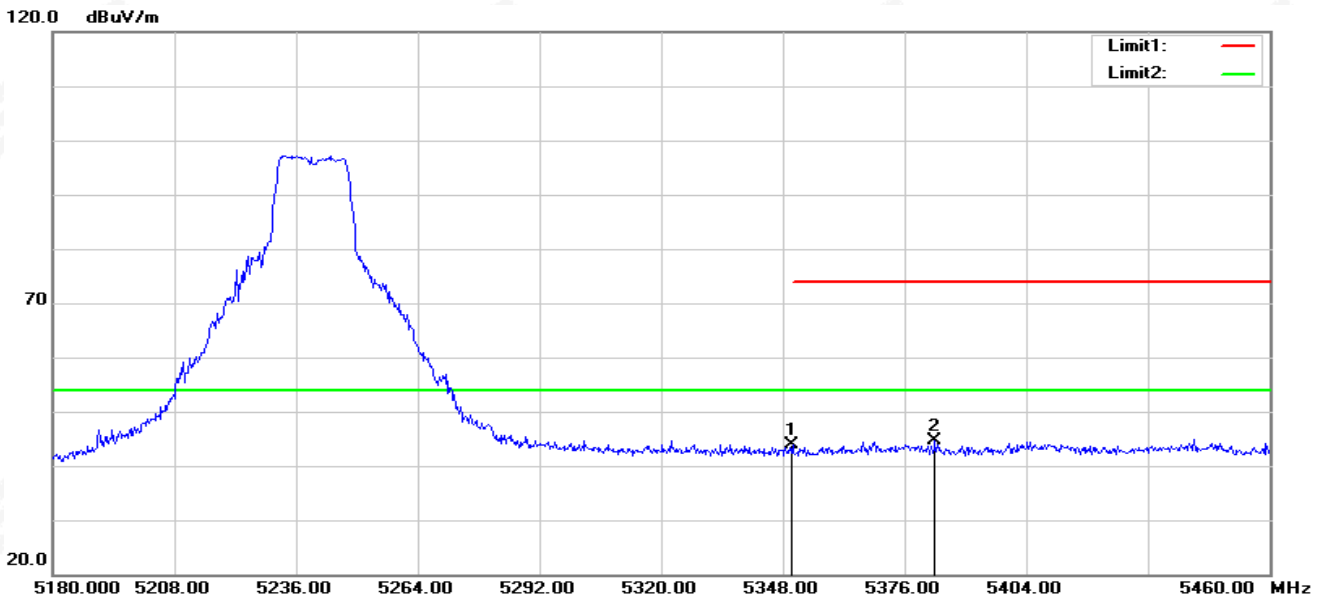

No.	Frequency (MHz)	Reading (dBuV)	Correct Factor(dB/m)	Result (dBuV/m)	Limit (dBuV/m)	Margin (dB)	Remark
1	5350.000	49.17	-5.23	43.94	74.00	-30.06	peak
2	5383.000	49.79	-5.24	44.55	74.00	-29.45	peak



802.11ac40-L-H

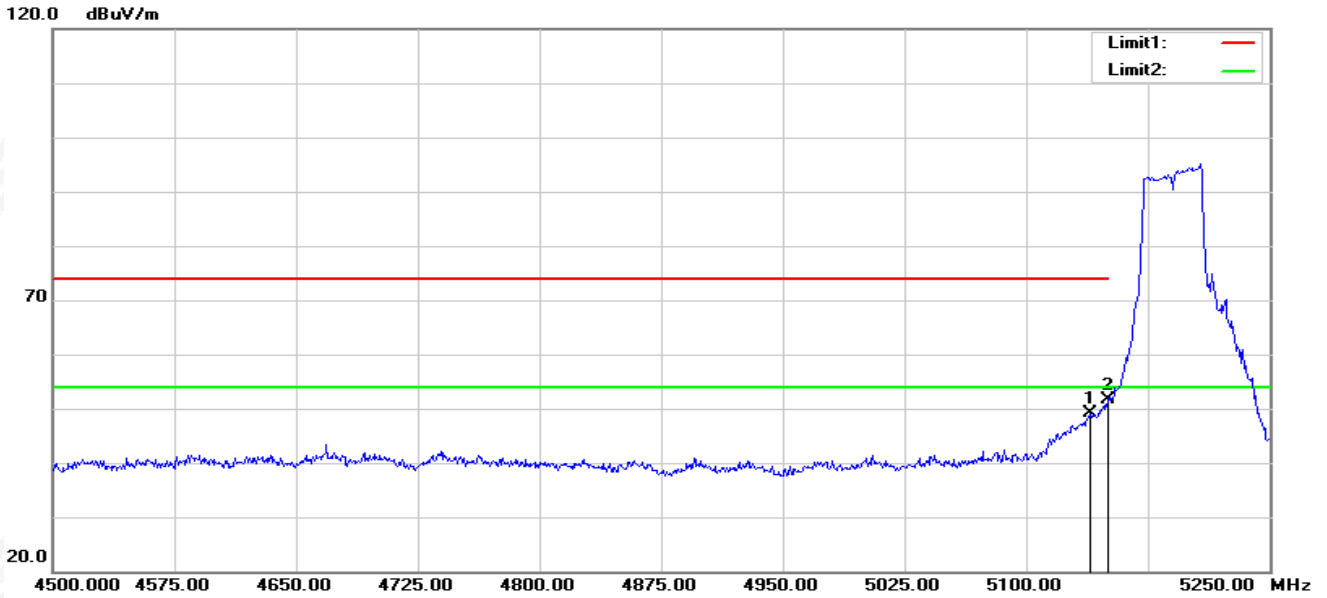

No.	Frequency (MHz)	Reading (dBuV)	Correct Factor(dB/m)	Result (dBuV/m)	Limit (dBuV/m)	Margin (dB)	Remark
1	5139.000	54.95	-5.74	49.21	74.00	-24.79	peak
2	5150.000	57.35	-5.73	51.62	74.00	-22.38	peak

802.11ac40-L-V

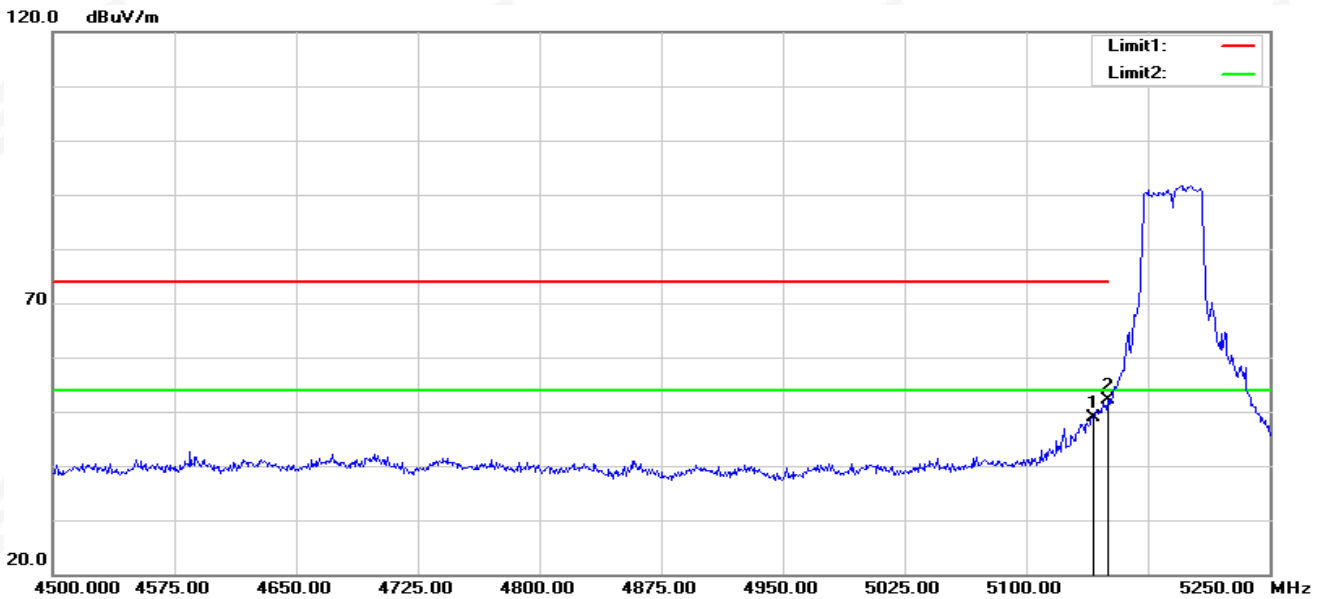

No.	Frequency (MHz)	Reading (dBuV)	Correct Factor(dB/m)	Result (dBuV/m)	Limit (dBuV/m)	Margin (dB)	Remark
1	5141.250	54.58	-5.74	48.84	74.00	-25.16	peak
2	5150.000	57.85	-5.73	52.12	74.00	-21.88	peak



802.11ac40-H-H

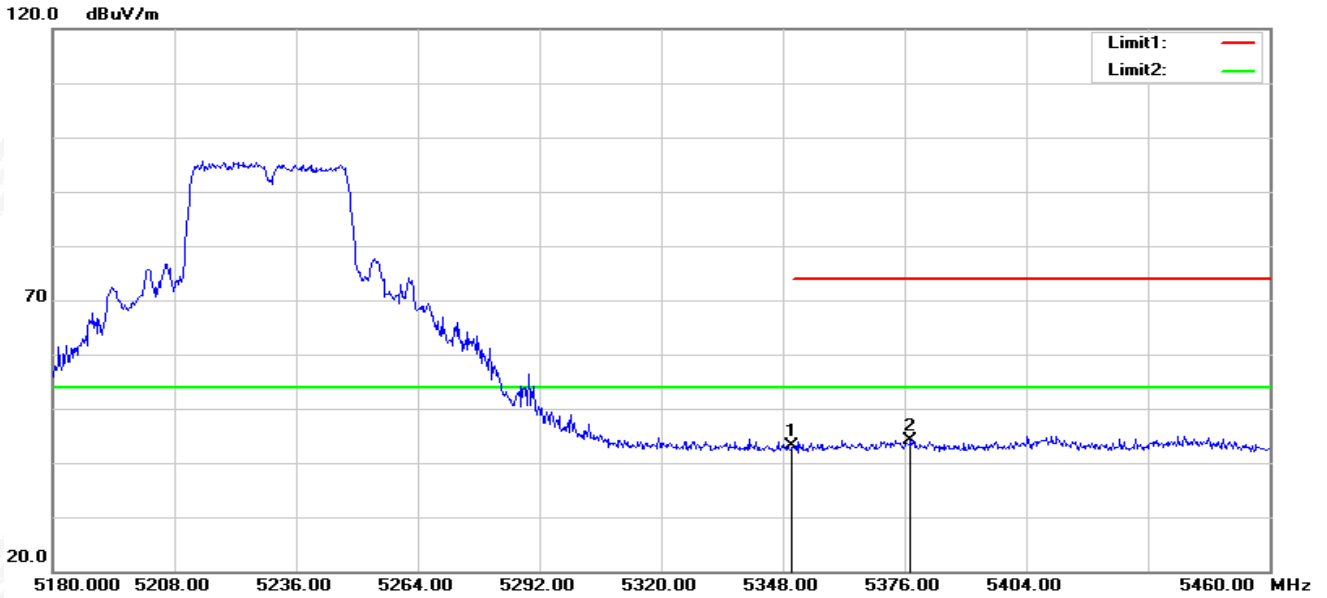

No.	Frequency (MHz)	Reading (dBuV)	Correct Factor(dB/m)	Result (dBuV/m)	Limit (dBuV/m)	Margin (dB)	Remark
1	5350.000	48.24	-5.23	43.01	74.00	-30.99	peak
2	5377.400	49.43	-5.24	44.19	74.00	-29.81	peak

802.11ac40-H-V

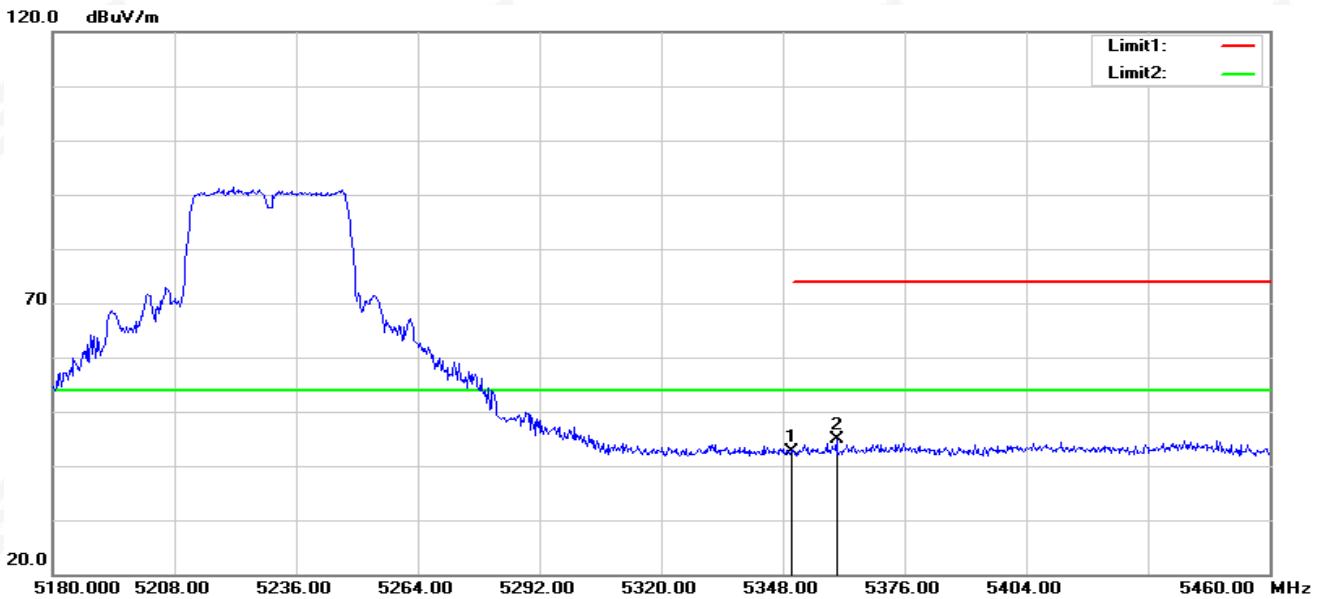

No.	Frequency (MHz)	Reading (dBuV)	Correct Factor(dB/m)	Result (dBuV/m)	Limit (dBuV/m)	Margin (dB)	Remark
1	5350.000	47.79	-5.23	42.56	74.00	-31.44	peak
2	5360.320	50.08	-5.23	44.85	74.00	-29.15	peak

802.11ac80-L-H

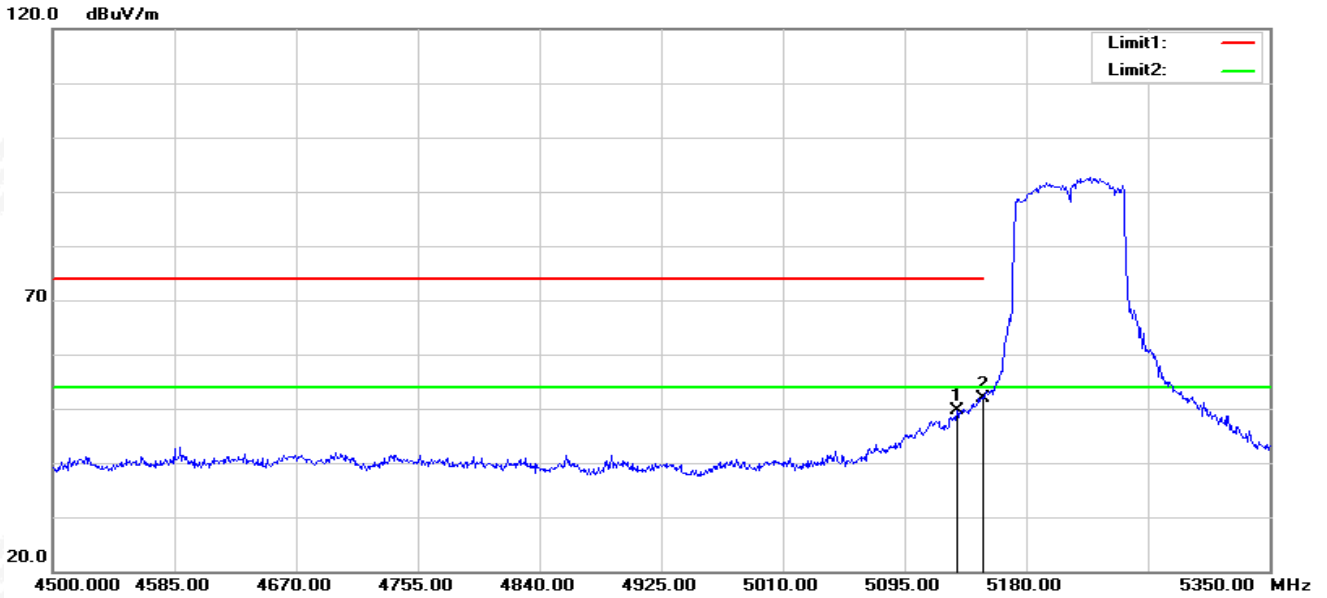

No.	Frequency (MHz)	Reading (dBuV)	Correct Factor(dB/m)	Result (dBuV/m)	Limit (dBuV/m)	Margin (dB)	Remark
1	5131.550	55.35	-5.73	49.62	74.00	-24.38	peak
2	5150.000	57.69	-5.73	51.96	74.00	-22.04	peak

802.11ac80-L-V

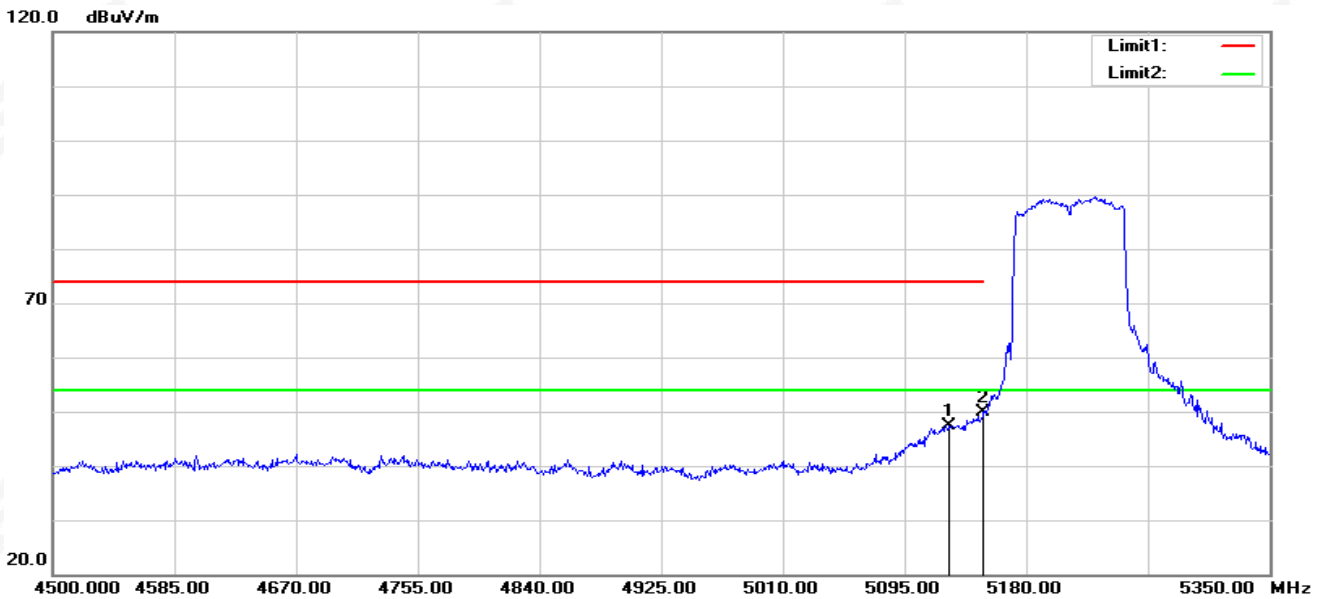

No.	Frequency (MHz)	Reading (dBuV)	Correct Factor(dB/m)	Result (dBuV/m)	Limit (dBuV/m)	Margin (dB)	Remark
1	5125.600	53.16	-5.74	47.42	74.00	-26.58	peak
2	5150.000	55.72	-5.73	49.99	74.00	-24.01	peak



802.11ac80-H-H

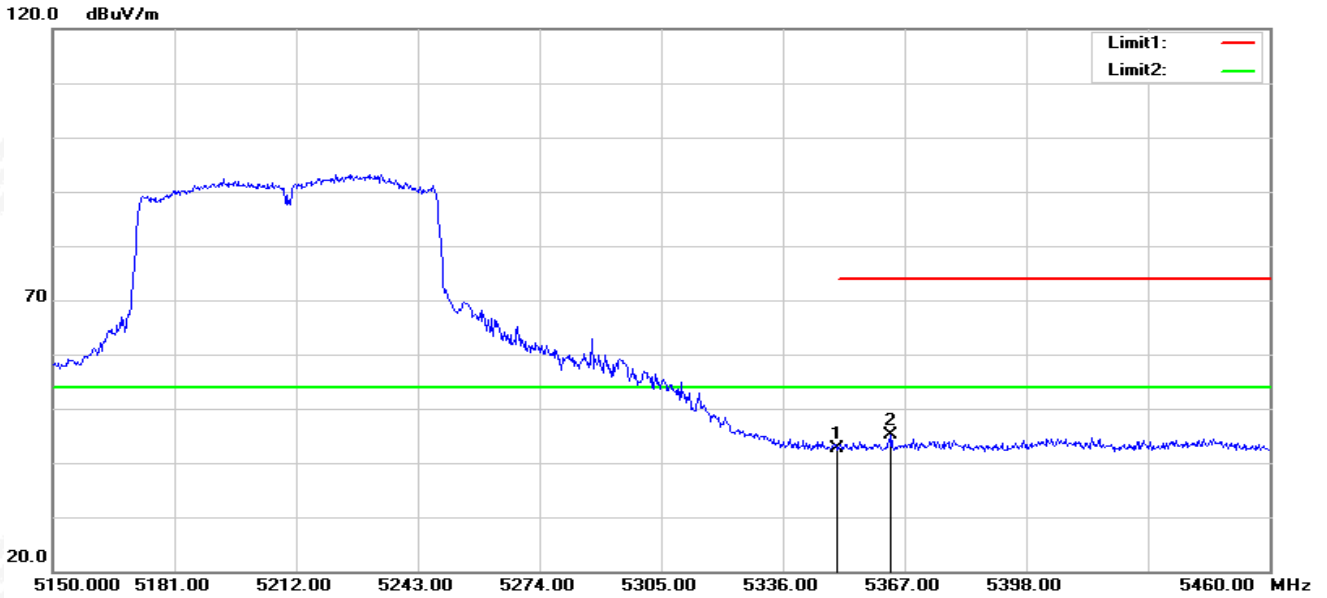

No.	Frequency (MHz)	Reading (dBuV)	Correct Factor(dB/m)	Result (dBuV/m)	Limit (dBuV/m)	Margin (dB)	Remark
1	5350.000	47.92	-5.23	42.69	74.00	-31.31	peak
2	5363.590	50.30	-5.24	45.06	74.00	-28.94	peak

802.11ac80-H-V

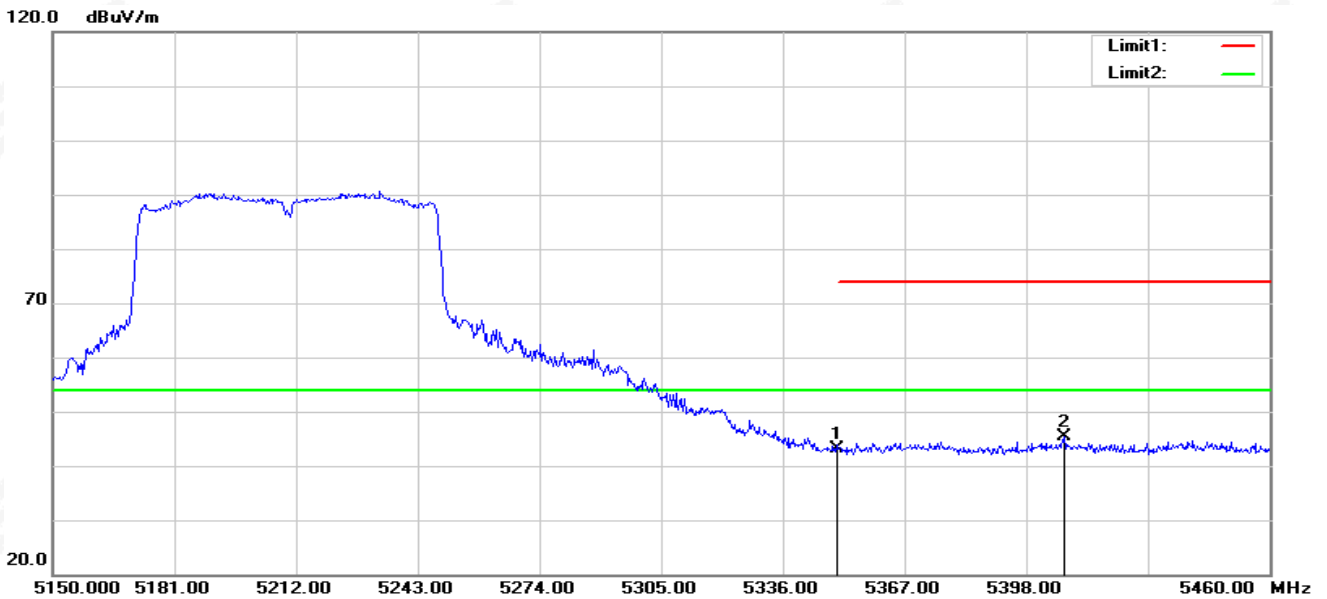

No.	Frequency (MHz)	Reading (dBuV)	Correct Factor(dB/m)	Result (dBuV/m)	Limit (dBuV/m)	Margin (dB)	Remark
1	5350.000	48.41	-5.23	43.18	74.00	-30.82	peak
2	5407.610	50.51	-5.23	45.28	74.00	-28.72	peak

Note: All modes have been tested. Only the worst mode shown in the report.



U-NII-2A 5250-5350MHz

802.11a20-L-H

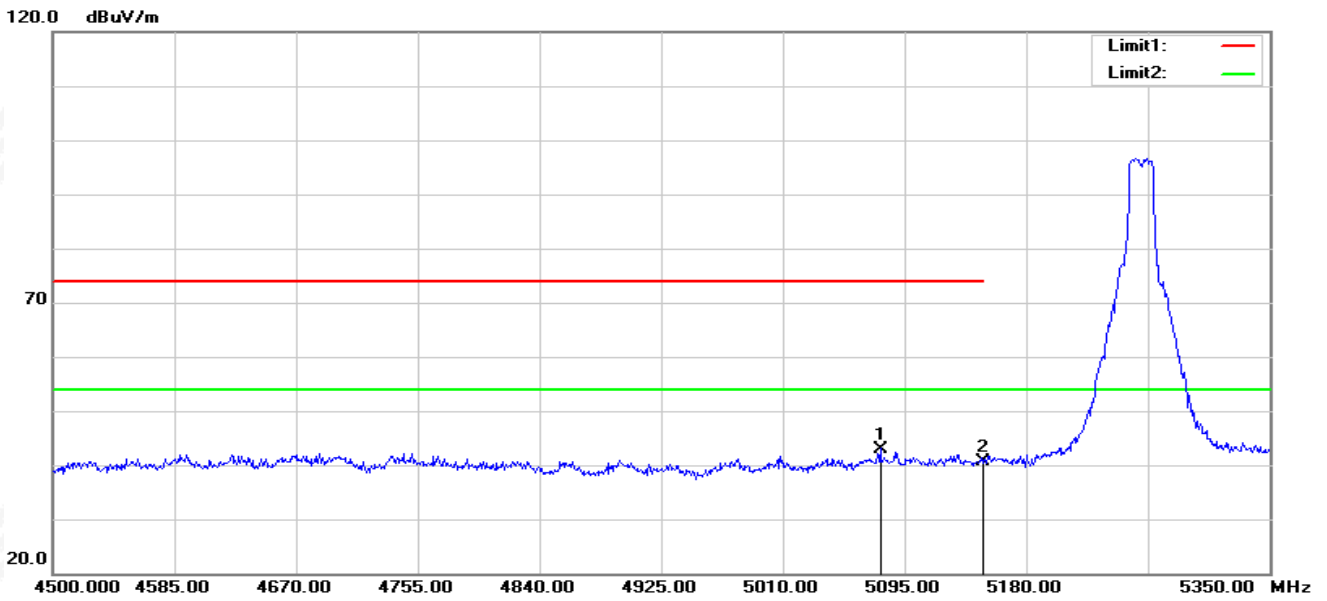

No.	Frequency (MHz)	Reading (dBuV)	Correct Factor(dB/m)	Result (dBuV/m)	Limit (dBuV/m)	Margin (dB)	Remark
1	5078.000	48.84	-5.84	43.00	74.00	-31.00	peak
2	5150.000	46.38	-5.73	40.65	74.00	-33.35	peak

802.11a20-L-V

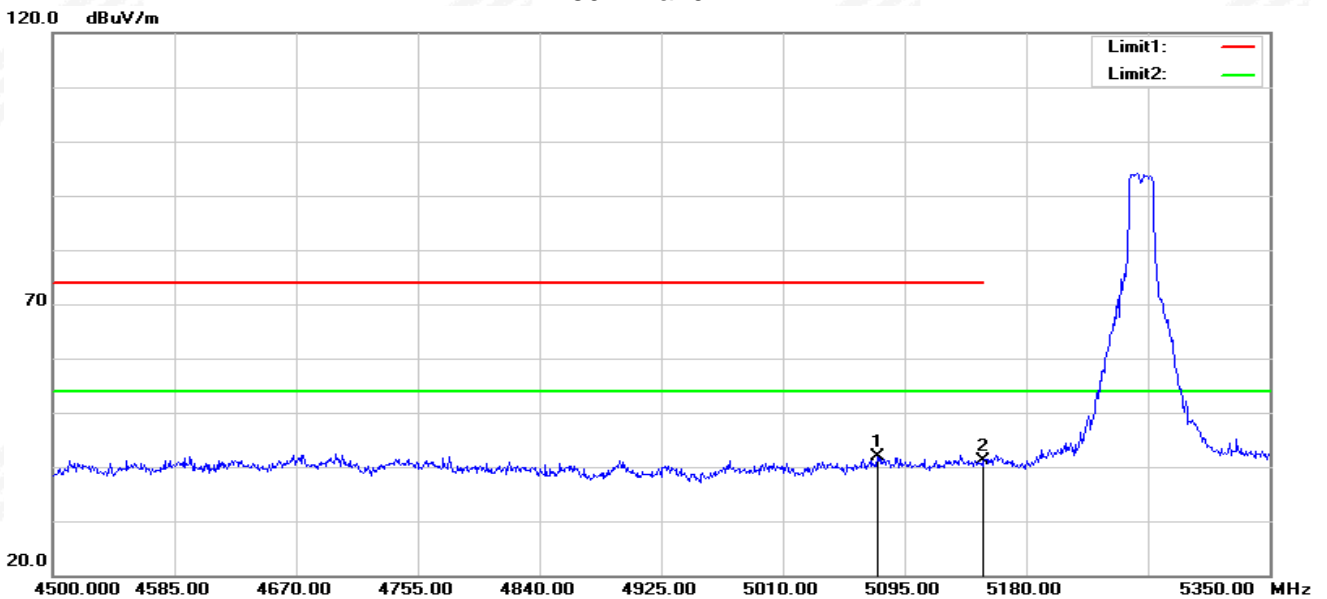

No.	Frequency (MHz)	Reading (dBuV)	Correct Factor(dB/m)	Result (dBuV/m)	Limit (dBuV/m)	Margin (dB)	Remark
1	5076.300	47.73	-5.85	41.88	74.00	-32.12	peak
2	5150.000	46.84	-5.73	41.11	74.00	-32.89	peak

802.11a20-H-H

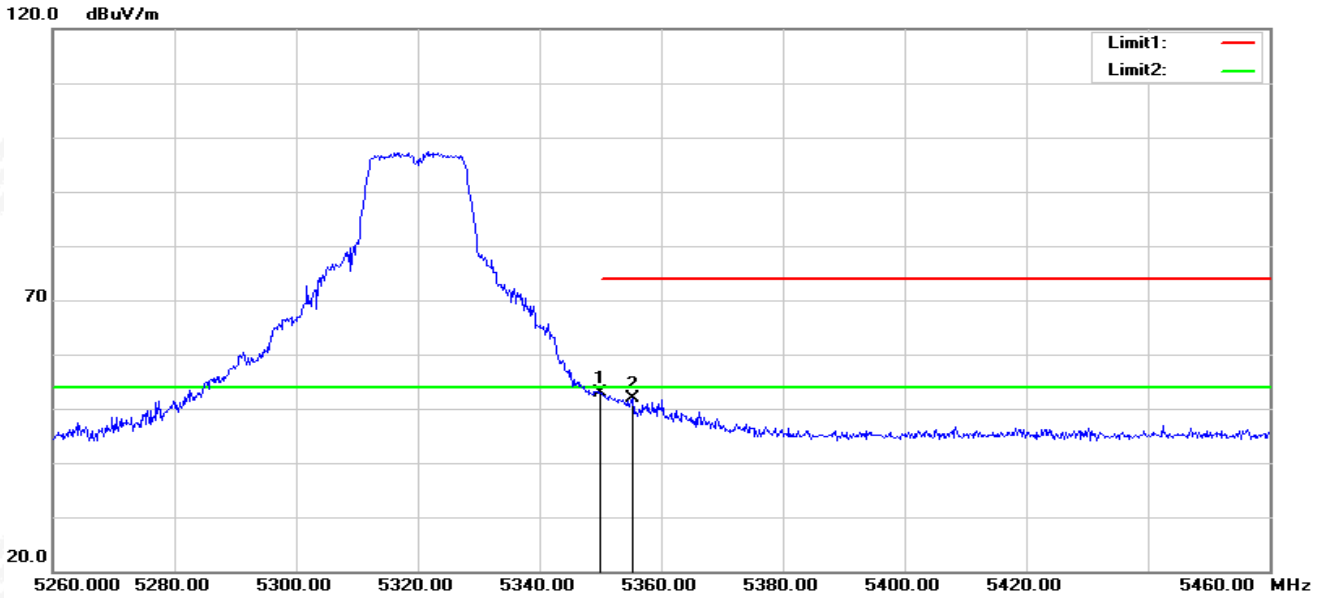

No.	Frequency (MHz)	Reading (dBuV)	Correct Factor(dB/m)	Result (dBuV/m)	Limit (dBuV/m)	Margin (dB)	Remark
1	5350.000	58.12	-5.23	52.89	74.00	-21.11	peak
2	5355.400	57.20	-5.24	51.96	74.00	-22.04	peak

802.11a20-H-V

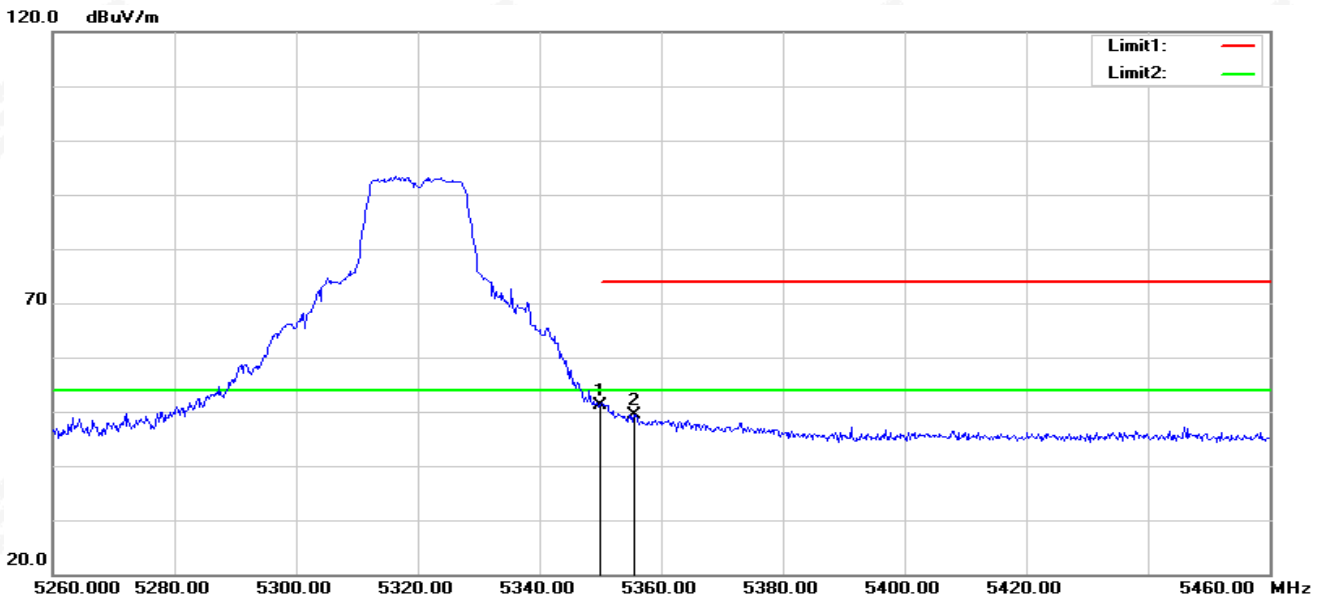

No.	Frequency (MHz)	Reading (dBuV)	Correct Factor(dB/m)	Result (dBuV/m)	Limit (dBuV/m)	Margin (dB)	Remark
1	5350.000	56.36	-5.23	51.13	74.00	-22.87	peak
2	5355.600	54.71	-5.24	49.47	74.00	-24.53	peak



802.11ac40-L-H

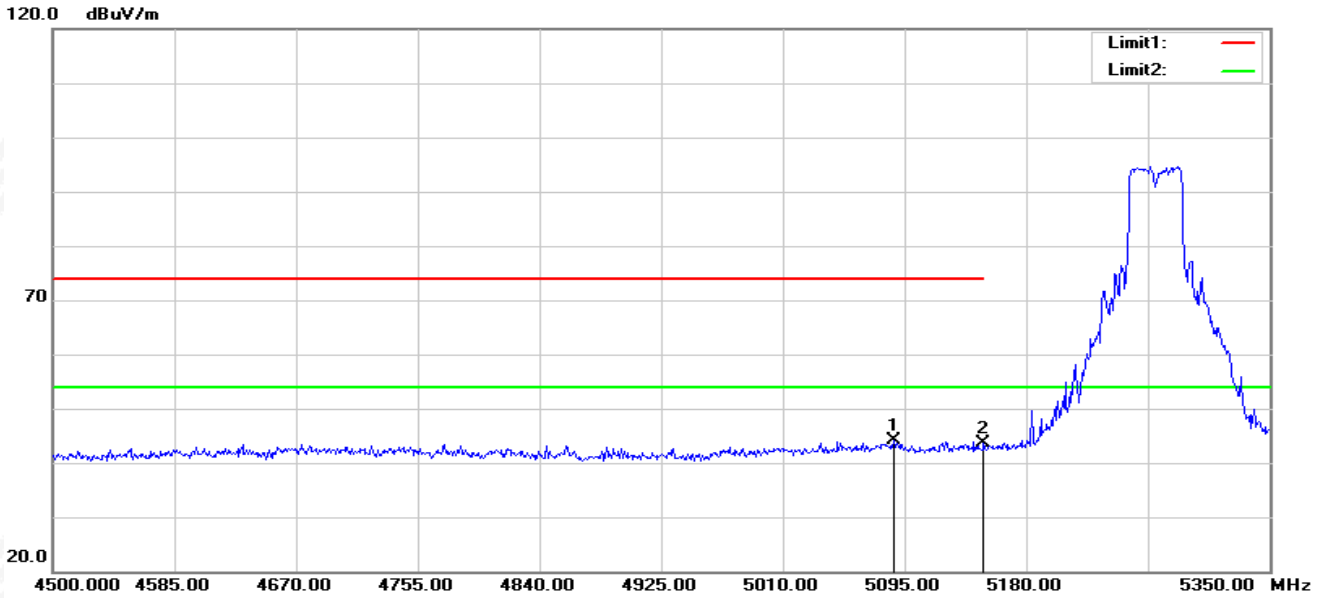

No.	Frequency (MHz)	Reading (dBuV)	Correct Factor(dB/m)	Result (dBuV/m)	Limit (dBuV/m)	Margin (dB)	Remark
1	5087.350	50.02	-5.80	44.22	74.00	-29.78	peak
2	5150.000	49.42	-5.73	43.69	74.00	-30.31	peak

802.11ac40-L-V

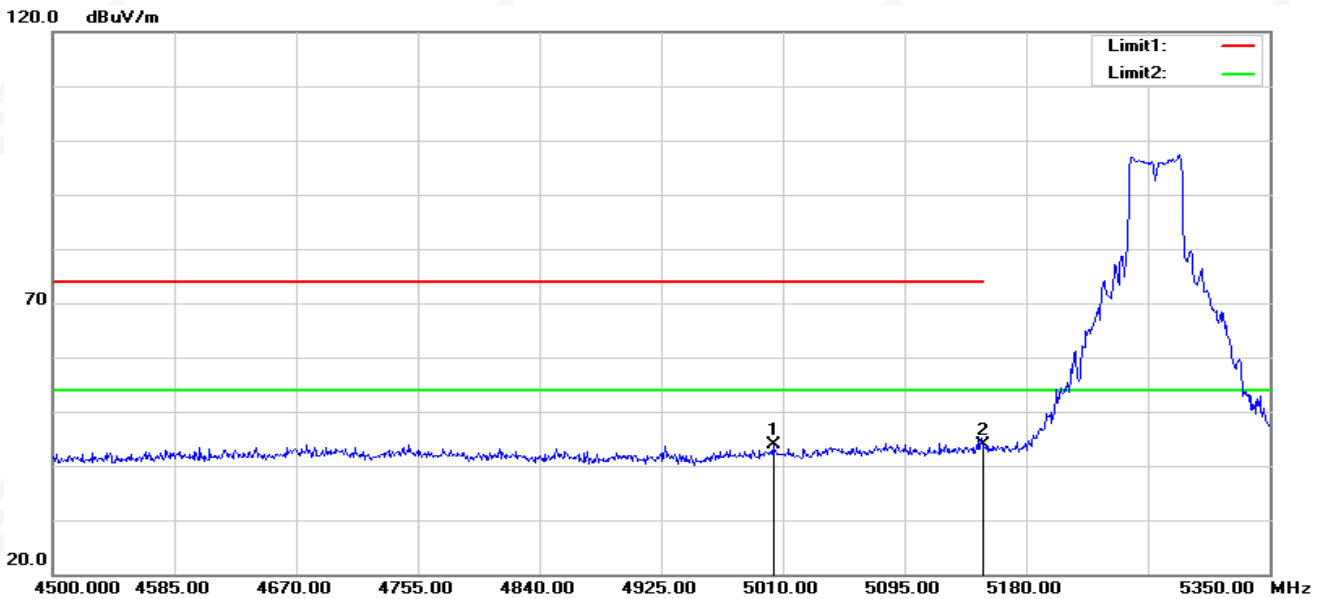

No.	Frequency (MHz)	Reading (dBuV)	Correct Factor(dB/m)	Result (dBuV/m)	Limit (dBuV/m)	Margin (dB)	Remark
1	5003.200	50.14	-6.18	43.96	74.00	-30.04	peak
2	5150.000	49.63	-5.73	43.90	74.00	-30.10	peak

802.11ac40-H-H

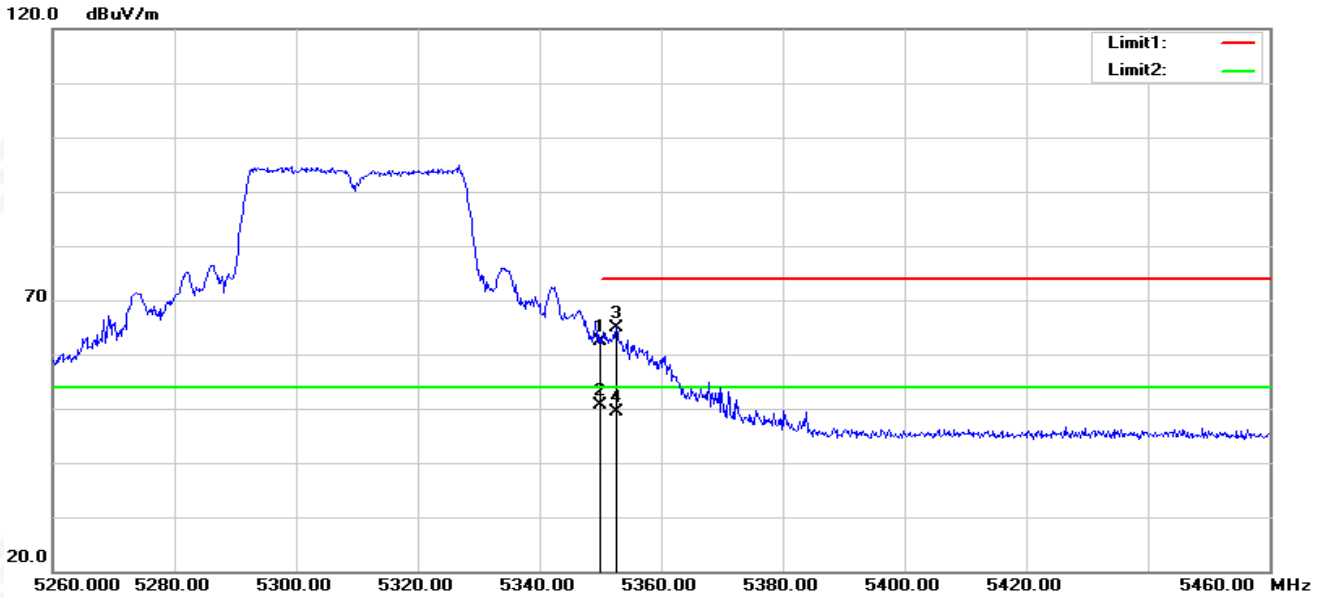

No.	Frequency (MHz)	Reading (dBuV)	Correct Factor(dB/m)	Result (dBuV/m)	Limit (dBuV/m)	Margin (dB)	Remark
1	5350.000	67.67	-5.23	62.44	74.00	-11.56	peak
2	5350.000	55.81	-5.23	50.58	54.00	-3.42	AVG
3	5352.600	70.23	-5.23	65.00	74.00	-9.00	peak
4	5352.600	54.57	-5.23	49.34	54.00	-4.66	AVG

802.11ac40-H-V

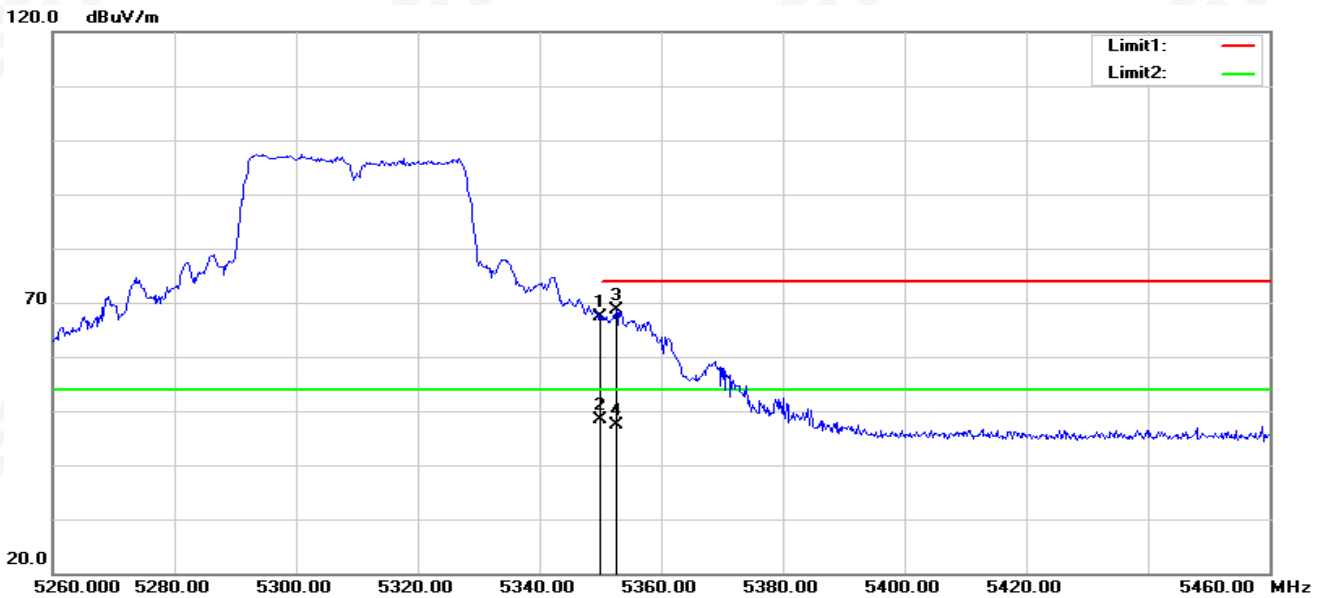

No.	Frequency (MHz)	Reading (dBuV)	Correct Factor(dB/m)	Result (dBuV/m)	Limit (dBuV/m)	Margin (dB)	Remark
1	5350.000	72.58	-5.23	67.35	74.00	-6.65	peak
2	5350.000	53.50	-5.23	48.27	54.00	-5.73	AVG
3	5352.600	73.90	-5.23	68.67	74.00	-5.33	peak
4	5352.600	52.53	-5.23	47.30	54.00	-6.70	AVG



802.11ac80-L-H

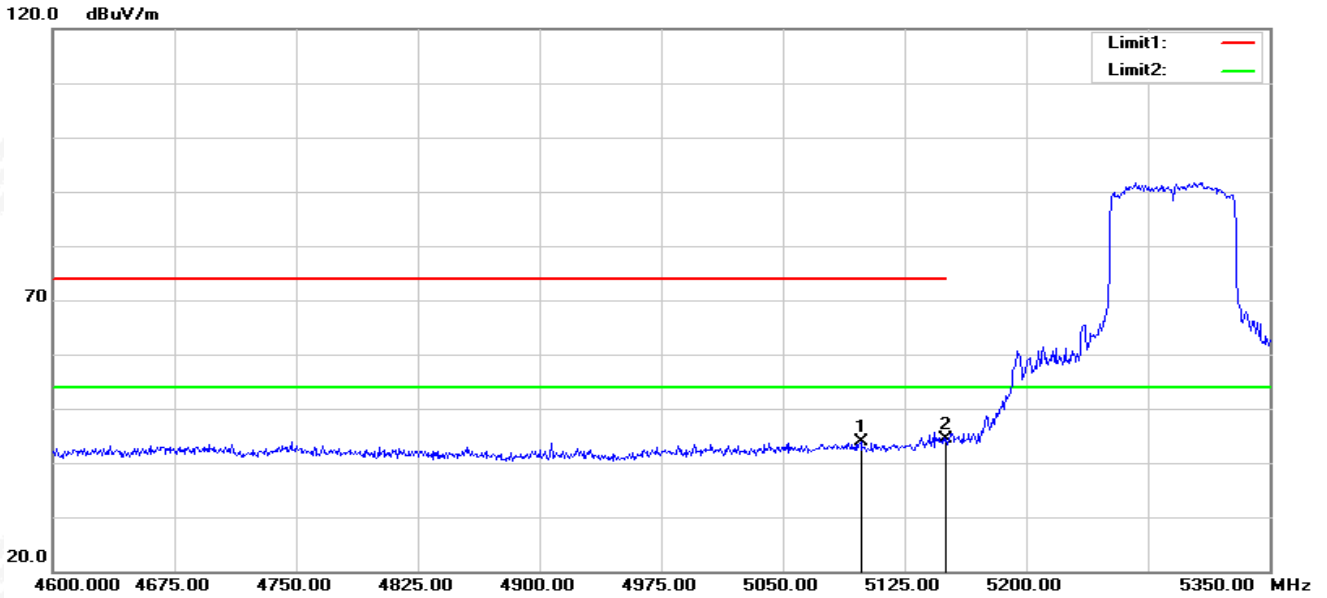

No.	Frequency (MHz)	Reading (dBuV)	Correct Factor(dB/m)	Result (dBuV/m)	Limit (dBuV/m)	Margin (dB)	Remark
1	5098.000	49.54	-5.75	43.79	74.00	-30.21	peak
2	5150.000	50.00	-5.73	44.27	74.00	-29.73	peak

802.11ac80-L-V

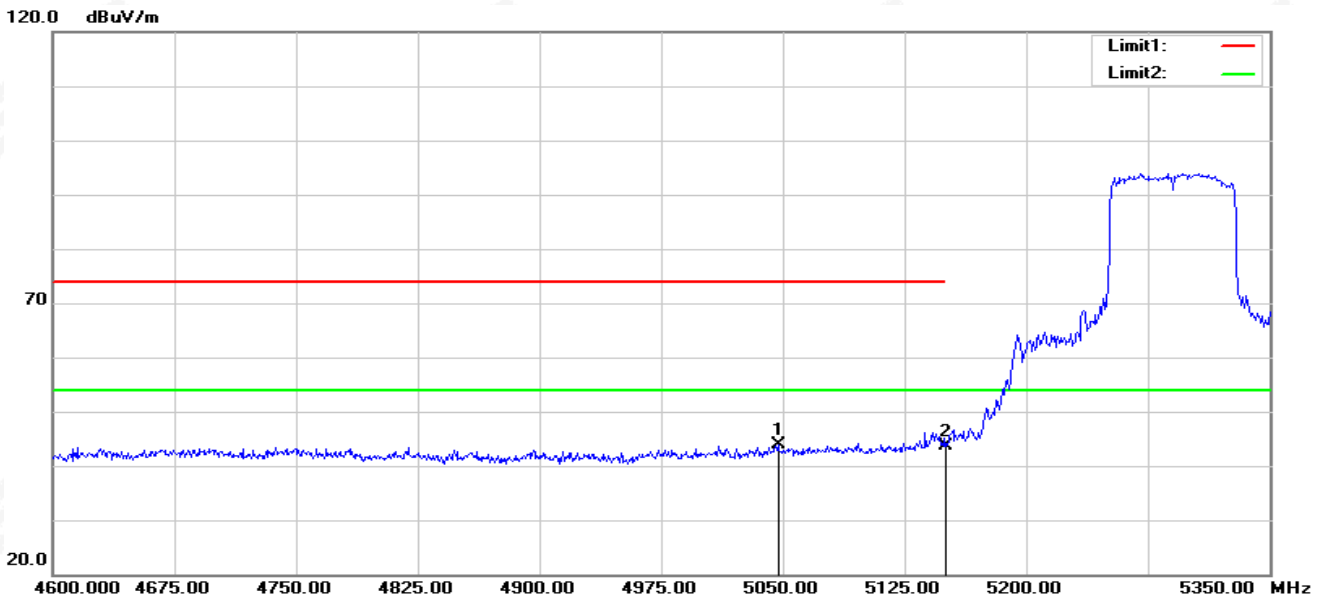

No.	Frequency (MHz)	Reading (dBuV)	Correct Factor(dB/m)	Result (dBuV/m)	Limit (dBuV/m)	Margin (dB)	Remark
1	5047.000	49.78	-5.98	43.80	74.00	-30.20	peak
2	5150.000	49.31	-5.73	43.58	74.00	-30.42	peak

802.11ac80-H-H

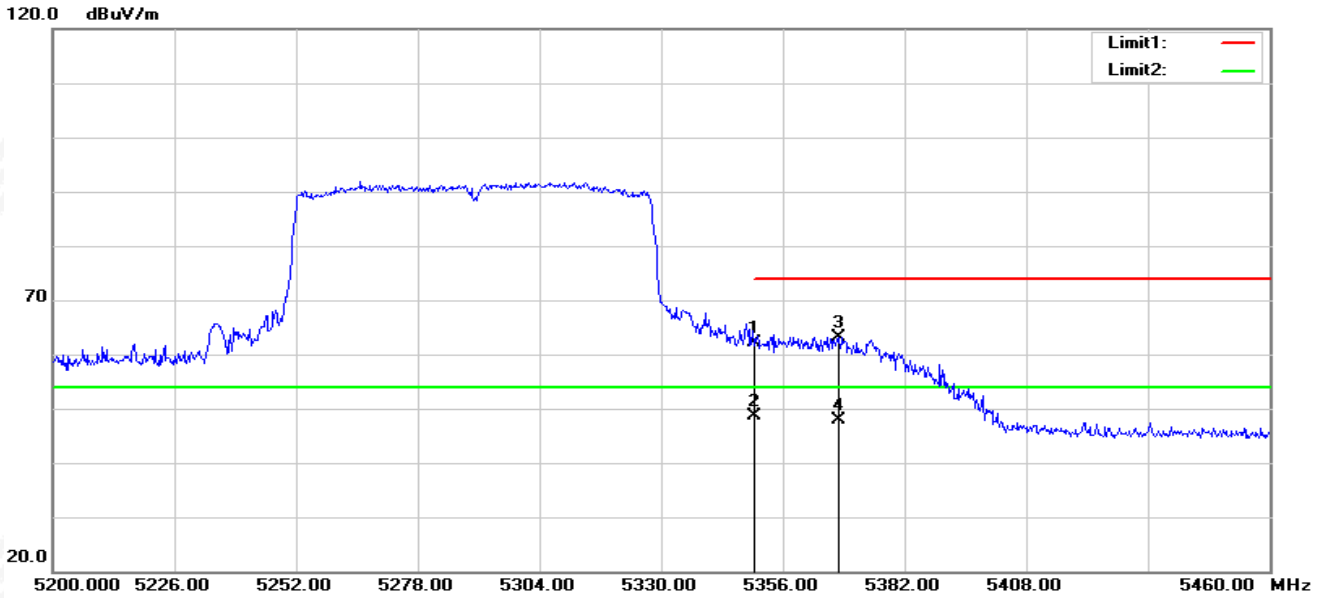

No.	Frequency (MHz)	Reading (dBuV)	Correct Factor(dB/m)	Result (dBuV/m)	Limit (dBuV/m)	Margin (dB)	Remark
1	5350.000	67.42	-5.23	62.19	74.00	-11.81	peak
2	5350.000	53.76	-5.23	48.53	54.00	-5.47	AVG
3	5367.960	68.48	-5.24	63.24	74.00	-10.76	peak
4	5367.960	53.17	-5.24	47.93	54.00	-6.07	AVG

802.11ac80-H-V

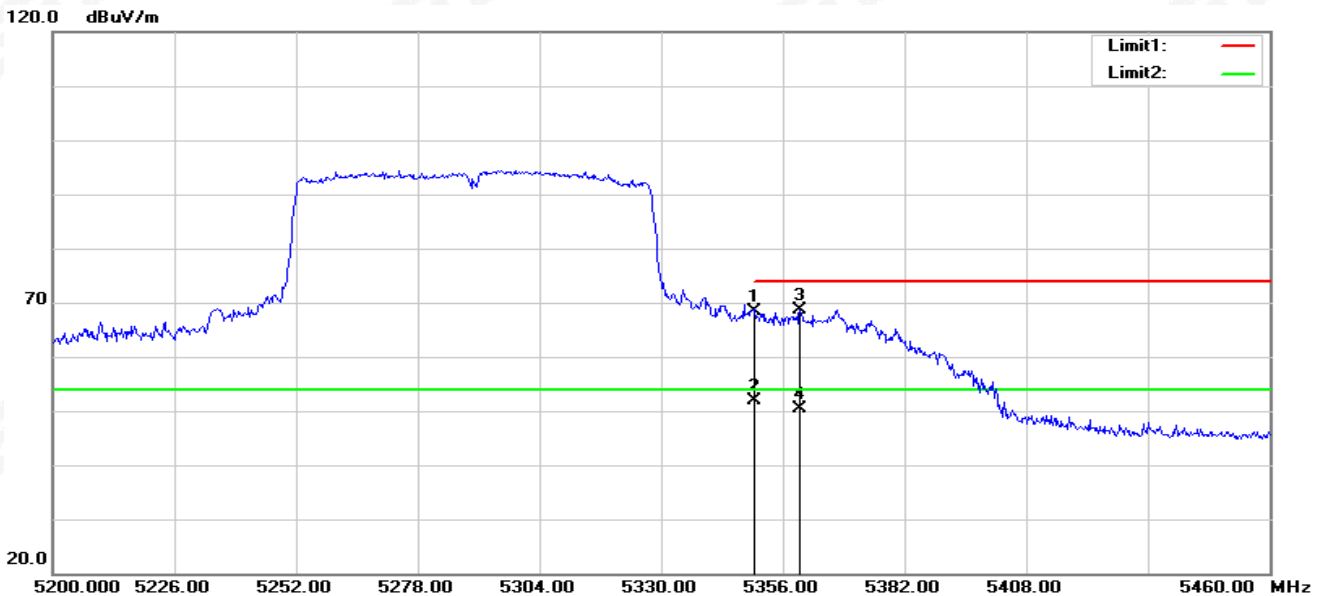

No.	Frequency (MHz)	Reading (dBuV)	Correct Factor(dB/m)	Result (dBuV/m)	Limit (dBuV/m)	Margin (dB)	Remark
1	5350.000	73.69	-5.23	68.46	74.00	-5.54	peak
2	5350.000	57.11	-5.23	51.88	54.00	-2.12	AVG
3	5359.640	73.90	-5.23	68.67	74.00	-5.33	peak
4	5359.640	55.70	-5.23	50.47	54.00	-3.53	AVG

Note: All modes have been tested. Only the worst mode shown in the report.

U-NII-2C 5470-5725MHz

802.11ac20-L-H

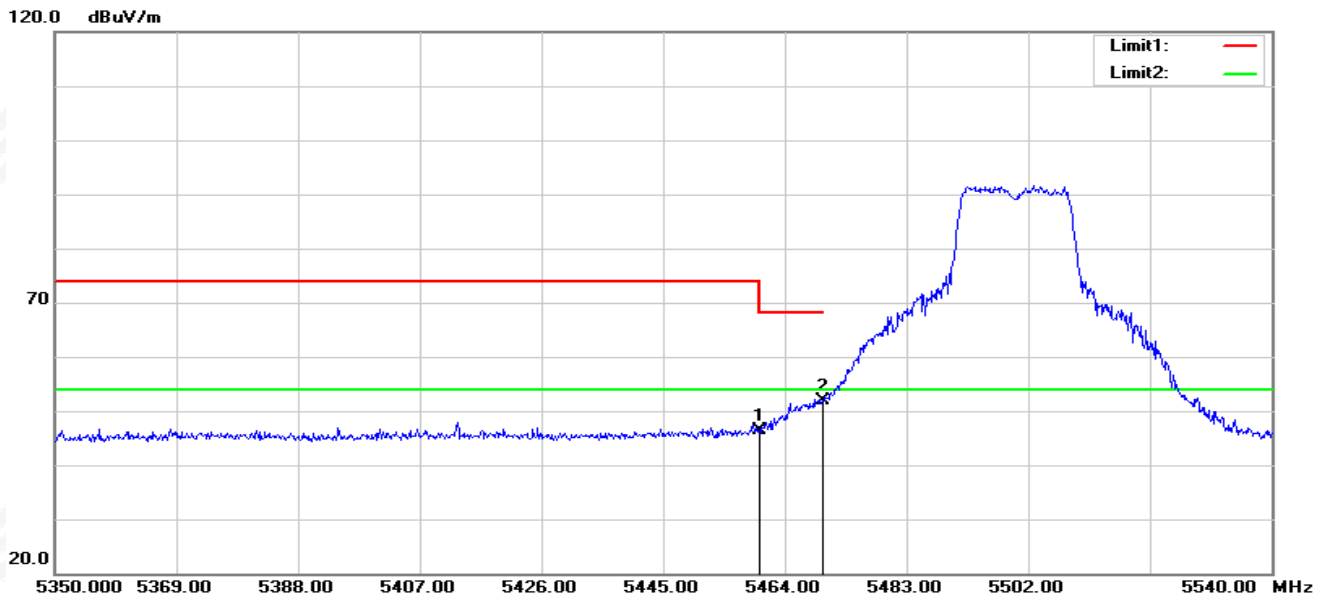

No.	Frequency (MHz)	Reading (dBuV)	Correct Factor(dB/m)	Result (dBuV/m)	Limit (dBuV/m)	Margin (dB)	Remark
1	5460.000	51.40	-5.11	46.29	68.20	-21.91	peak
2	5470.000	56.93	-5.09	51.84	68.20	-16.36	peak

802.11ac20-L-V

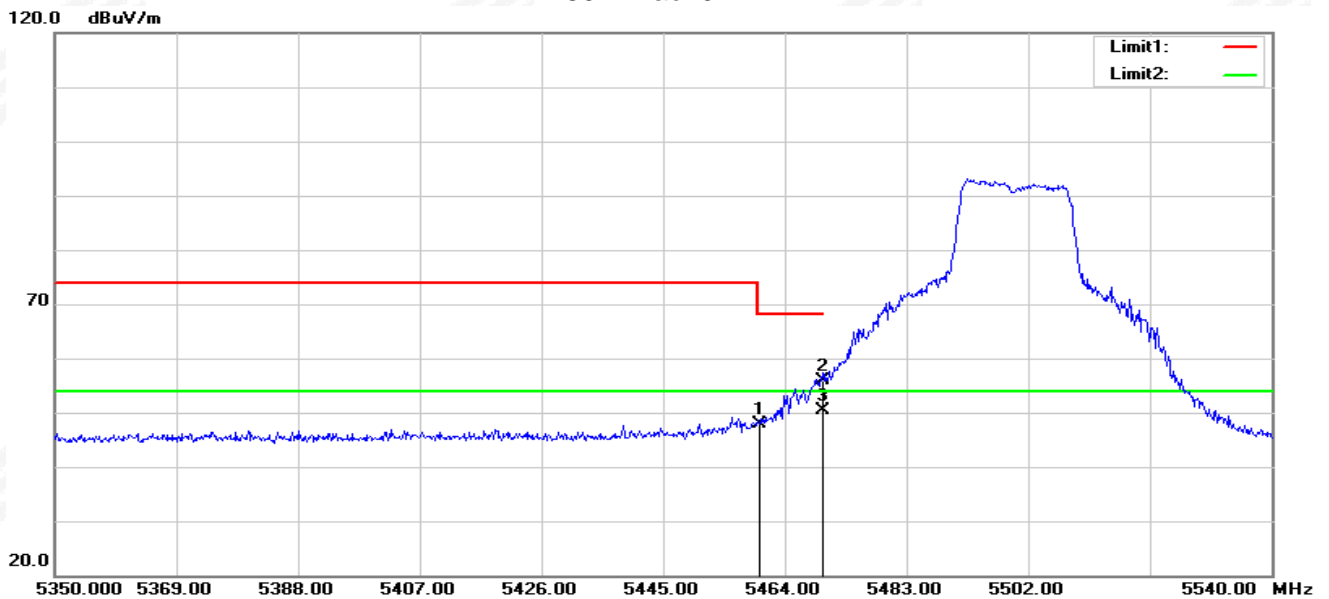

No.	Frequency (MHz)	Reading (dBuV)	Correct Factor(dB/m)	Result (dBuV/m)	Limit (dBuV/m)	Margin (dB)	Remark
1	5460.000	53.11	-5.11	48.00	68.20	-20.20	peak
2	5470.000	60.91	-5.09	55.82	68.20	-12.38	peak
3	5470.000	55.37	-5.09	50.28	54.00	-3.72	AVG



802.11ac20-H-H

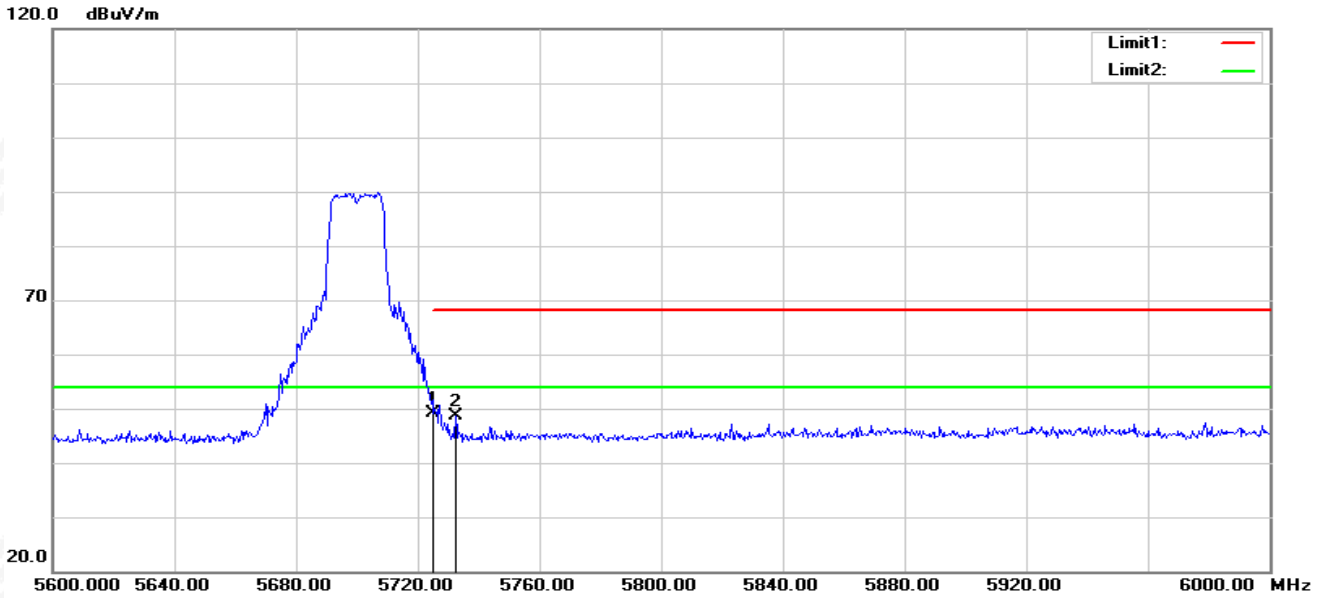

No.	Frequency (MHz)	Reading (dBuV)	Correct Factor(dB/m)	Result (dBuV/m)	Limit (dBuV/m)	Margin (dB)	Remark
1	5725.000	53.71	-4.57	49.14	68.20	-19.06	peak
2	5732.400	53.13	-4.55	48.58	68.20	-19.62	peak

802.11ac20-H-V

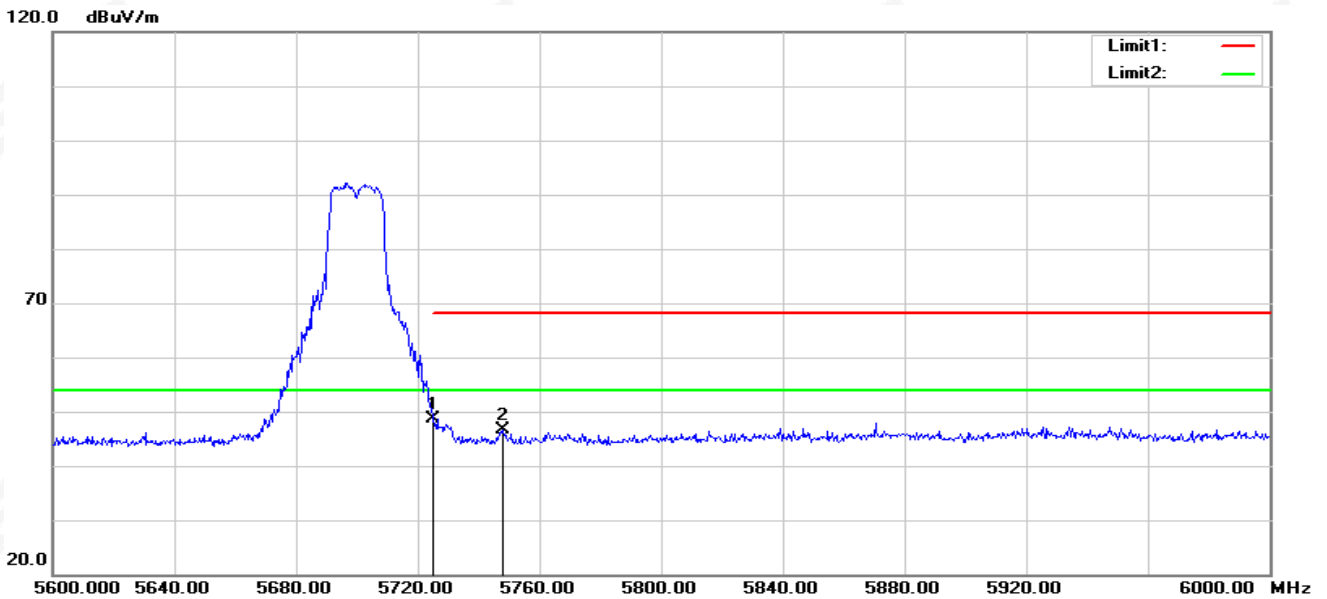

No.	Frequency (MHz)	Reading (dBuV)	Correct Factor(dB/m)	Result (dBuV/m)	Limit (dBuV/m)	Margin (dB)	Remark
1	5725.000	53.30	-4.57	48.73	68.20	-19.47	peak
2	5748.000	51.17	-4.49	46.68	68.20	-21.52	peak

802.11ac40-L-H

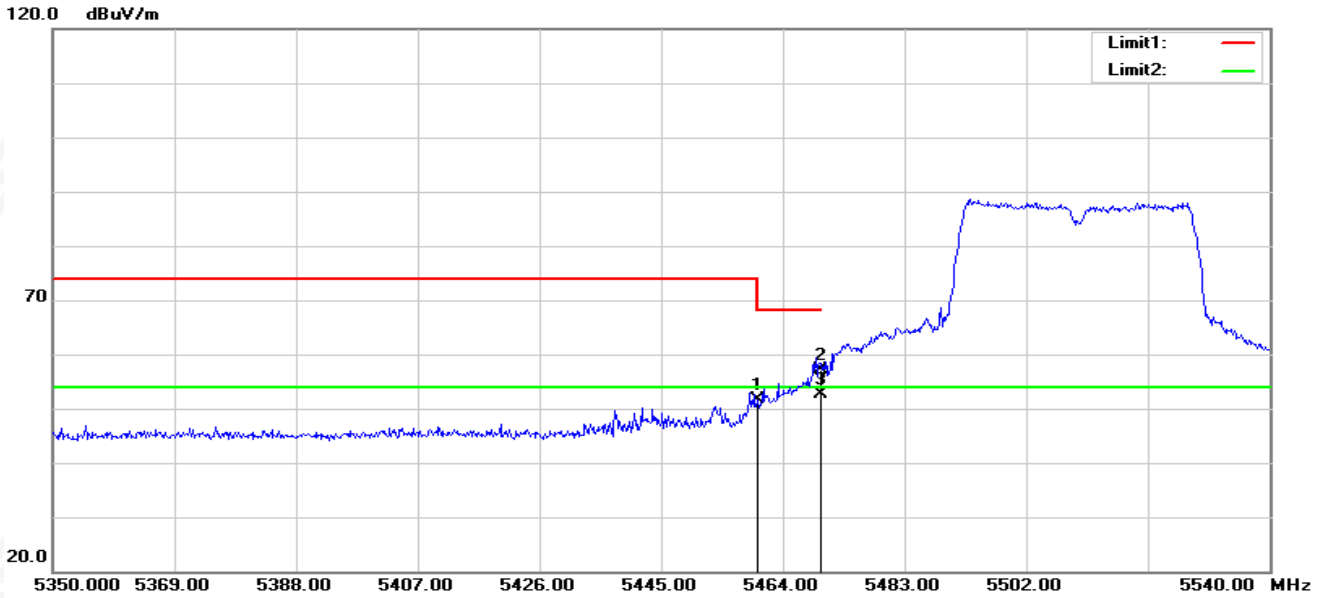

No.	Frequency (MHz)	Reading (dBuV)	Correct Factor(dB/m)	Result (dBuV/m)	Limit (dBuV/m)	Margin (dB)	Remark
1	5460.000	56.73	-5.11	51.62	68.20	-16.58	peak
2	5470.000	62.20	-5.09	57.11	68.20	-11.09	peak
3	5470.000	57.83	-5.09	52.74	54.00	-1.26	AVG

802.11ac40-L-V

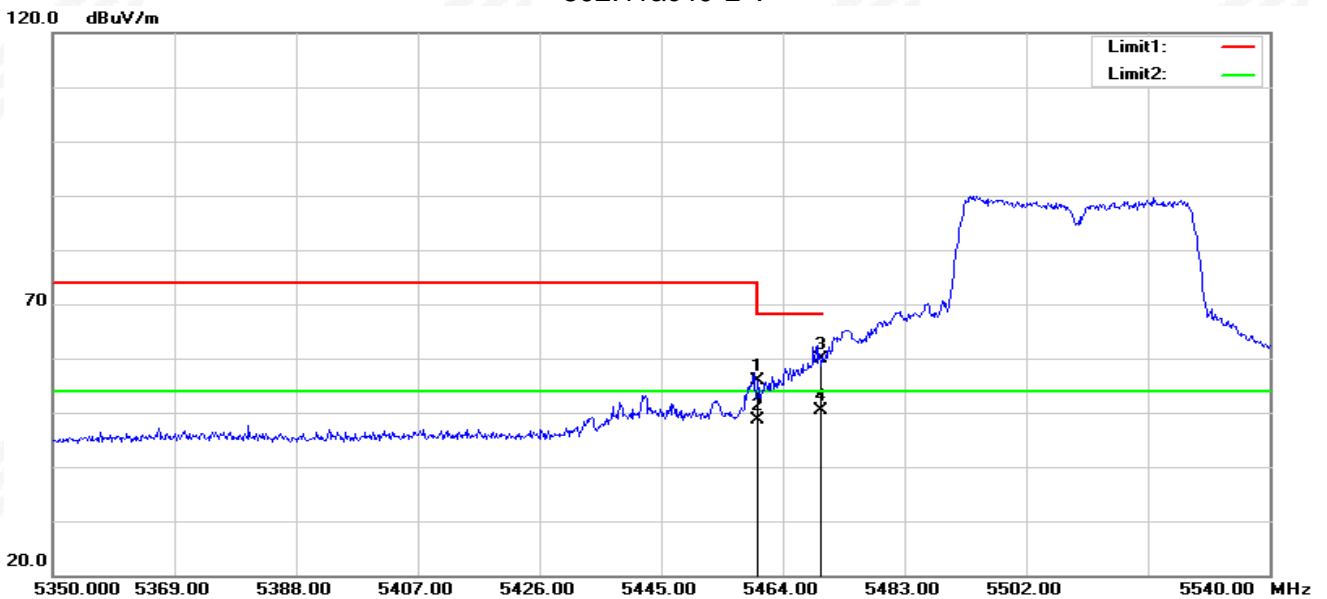

No.	Frequency (MHz)	Reading (dBuV)	Correct Factor(dB/m)	Result (dBuV/m)	Limit (dBuV/m)	Margin (dB)	Remark
1	5460.000	60.99	-5.11	55.88	68.20	-12.32	peak
2	5460.000	53.84	-5.11	48.73	54.00	-5.27	AVG
3	5470.000	64.87	-5.09	59.78	68.20	-8.42	peak
4	5470.000	55.51	-5.09	50.42	54.00	-3.58	AVG



802.11ac40-H-H

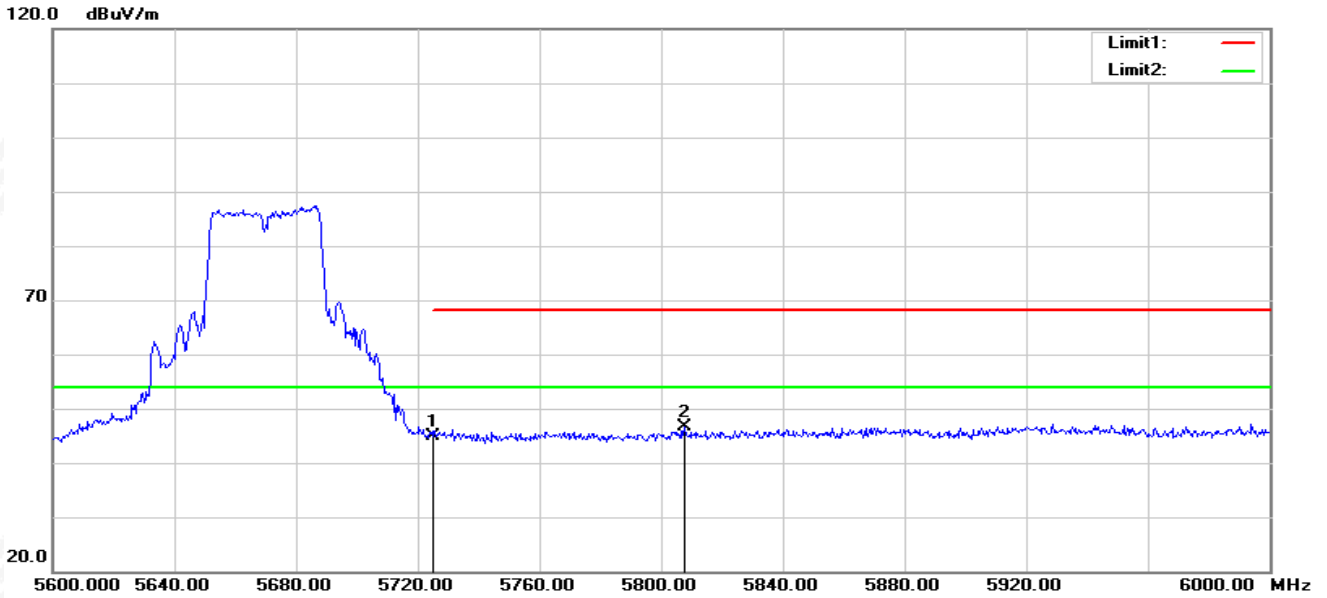

No.	Frequency (MHz)	Reading (dBuV)	Correct Factor(dB/m)	Result (dBuV/m)	Limit (dBuV/m)	Margin (dB)	Remark
1	5725.000	49.45	-4.57	44.88	68.20	-23.32	peak
2	5807.600	50.92	-4.29	46.63	68.20	-21.57	peak

802.11ac40-H-V

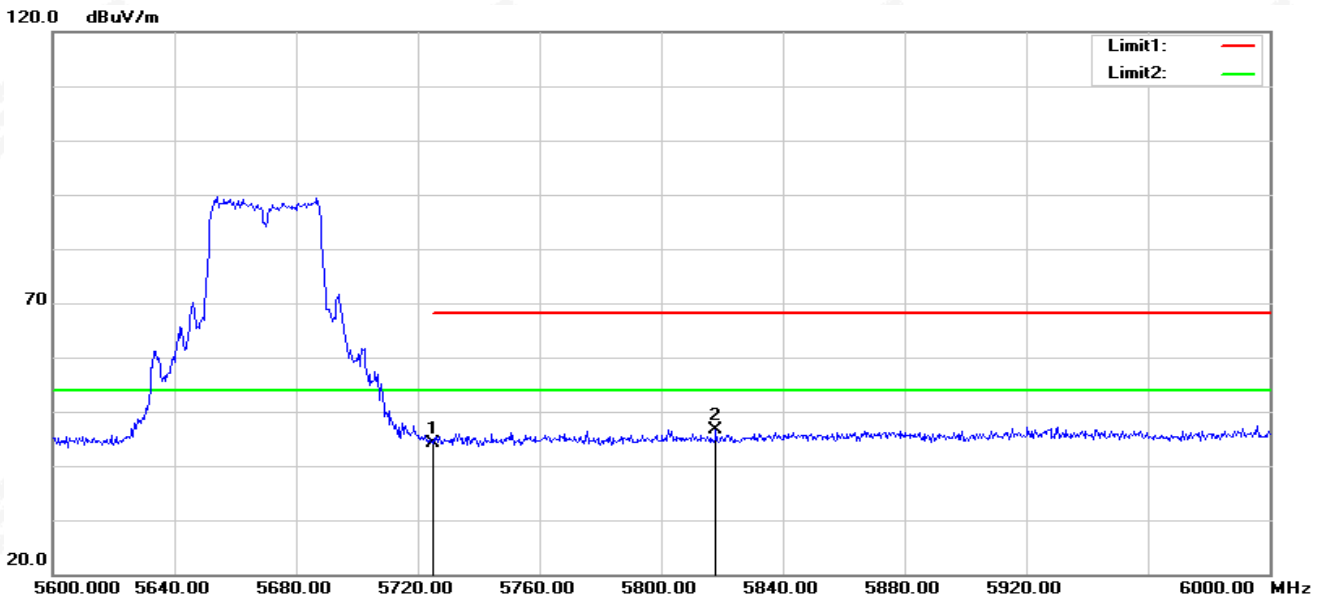

No.	Frequency (MHz)	Reading (dBuV)	Correct Factor(dB/m)	Result (dBuV/m)	Limit (dBuV/m)	Margin (dB)	Remark
1	5725.000	48.65	-4.57	44.08	68.20	-24.12	peak
2	5818.000	50.78	-4.24	46.54	68.20	-21.66	peak



802.11ac80-L-H

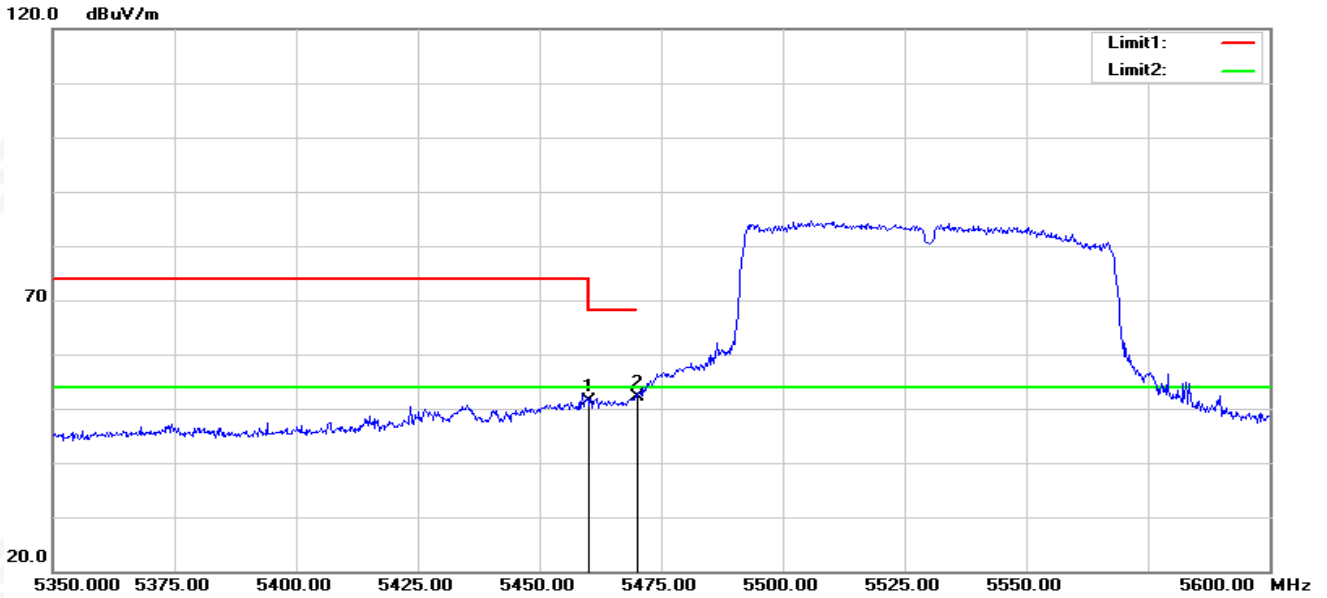

No.	Frequency (MHz)	Reading (dBuV)	Correct Factor(dB/m)	Result (dBuV/m)	Limit (dBuV/m)	Margin (dB)	Remark
1	5460.000	56.42	-5.11	51.31	68.20	-16.89	peak
2	5470.000	57.18	-5.09	52.09	68.20	-16.11	peak

802.11ac80-L-V

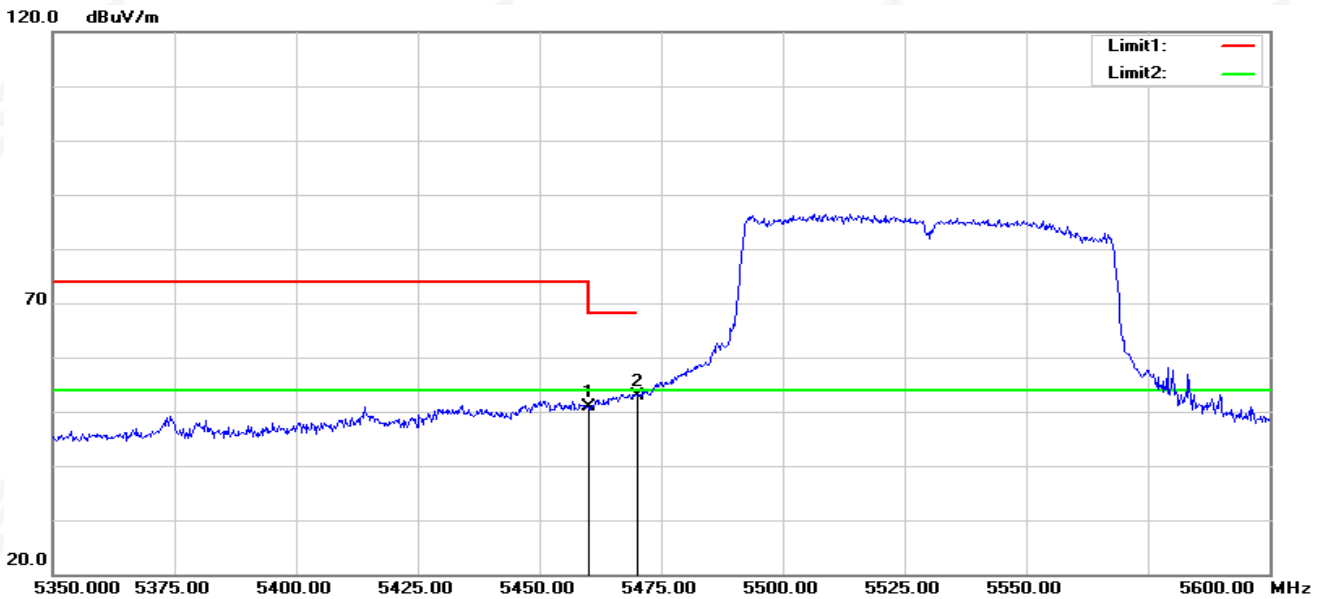

No.	Frequency (MHz)	Reading (dBuV)	Correct Factor(dB/m)	Result (dBuV/m)	Limit (dBuV/m)	Margin (dB)	Remark
1	5460.000	56.02	-5.11	50.91	68.20	-17.29	peak
2	5470.000	58.03	-5.09	52.94	68.20	-15.26	peak



802.11ac80-H-H

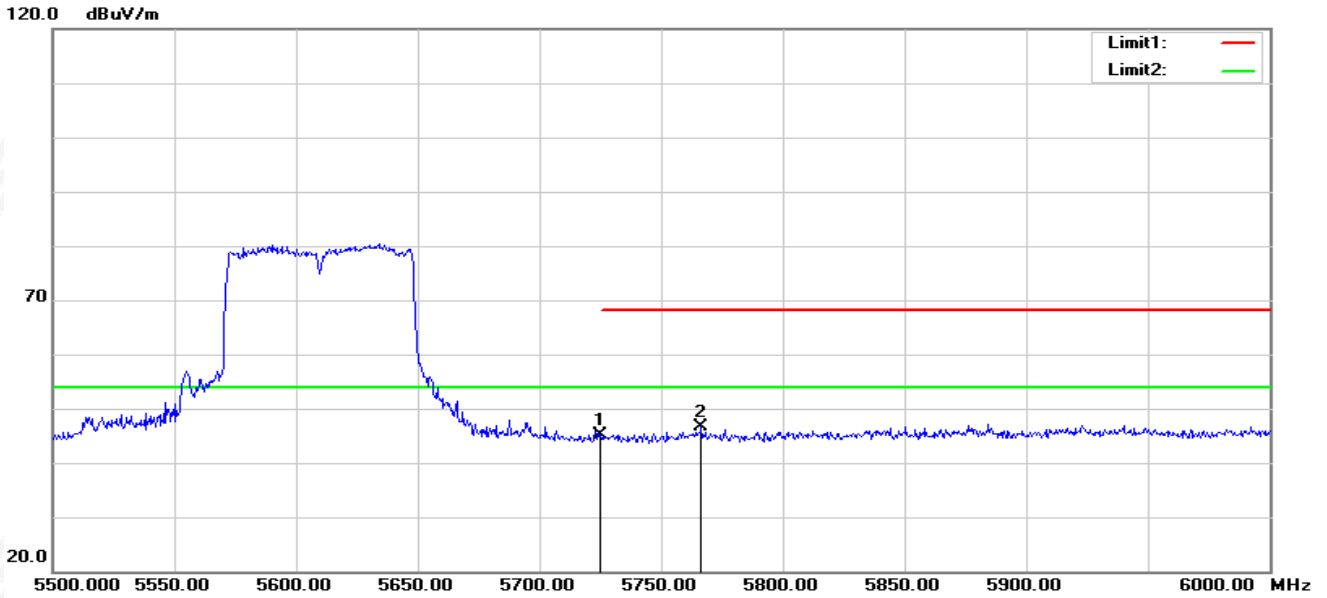

No.	Frequency (MHz)	Reading (dBuV)	Correct Factor(dB/m)	Result (dBuV/m)	Limit (dBuV/m)	Margin (dB)	Remark
1	5725.000	49.64	-4.57	45.07	68.20	-23.13	peak
2	5766.500	51.13	-4.43	46.70	68.20	-21.50	peak

802.11ac80-H-V

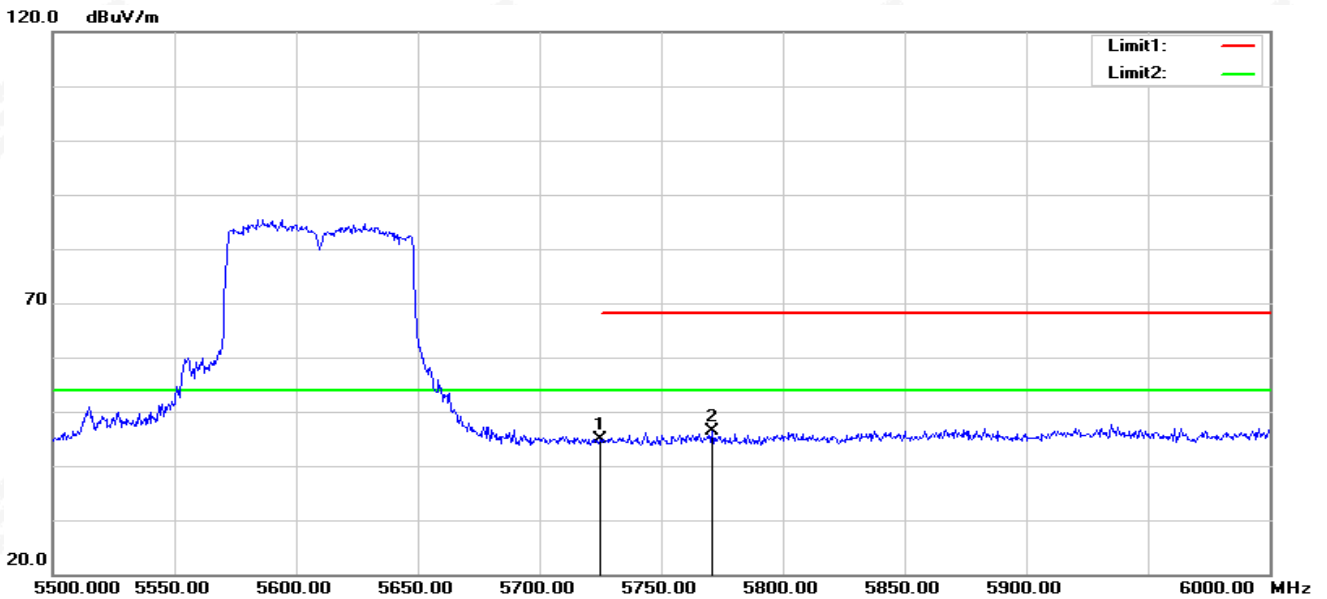

No.	Frequency (MHz)	Reading (dBuV)	Correct Factor(dB/m)	Result (dBuV/m)	Limit (dBuV/m)	Margin (dB)	Remark
1	5725.000	49.37	-4.57	44.80	68.20	-23.40	peak
2	5771.000	50.86	-4.42	46.44	68.20	-21.76	peak

Note: All modes have been tested. Only the worst mode shown in the report.

U-NII-3 (5.725-5.85 GHz)

802.11n20-L-H

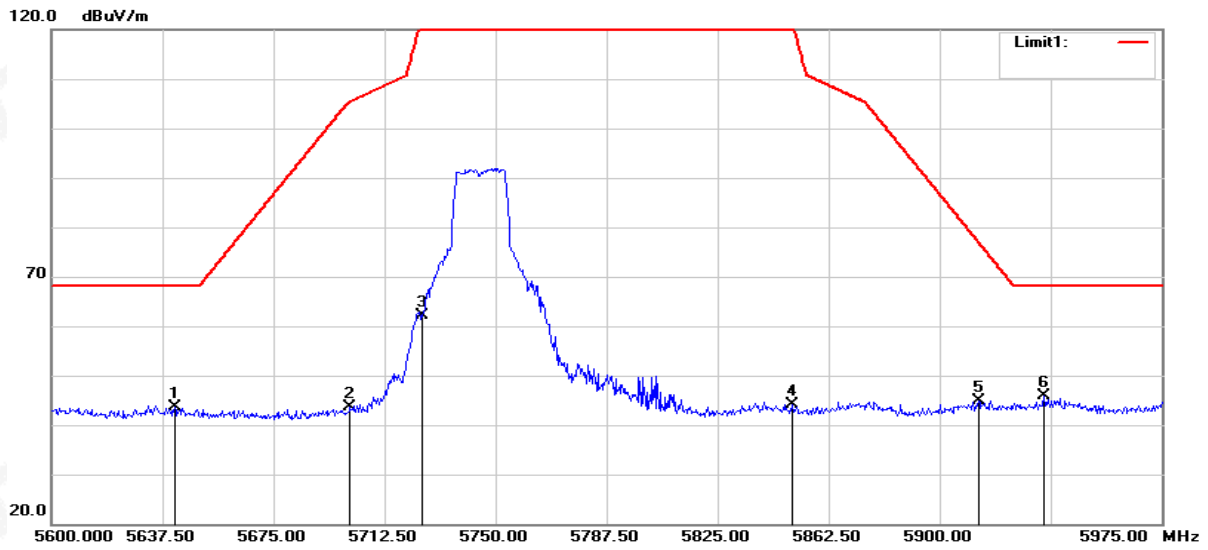

No.	Frequency (MHz)	Reading (dBuV)	Correct Factor(dB/m)	Result (dBuV/m)	Limit (dBuV/m)	Margin (dB)	Remark
1	5641.625	48.31	-4.68	43.63	68.20	-24.57	peak
2	5700.875	48.37	-4.66	43.71	105.45	-61.74	peak
3	5725.000	66.62	-4.57	62.05	122.20	-60.15	peak
4	5850.000	48.34	-4.10	44.24	122.20	-77.96	peak
5	5913.125	48.83	-3.90	44.93	76.99	-32.06	peak
6	5935.250	49.75	-3.94	45.81	68.20	-22.39	peak

802.11n20-L-V

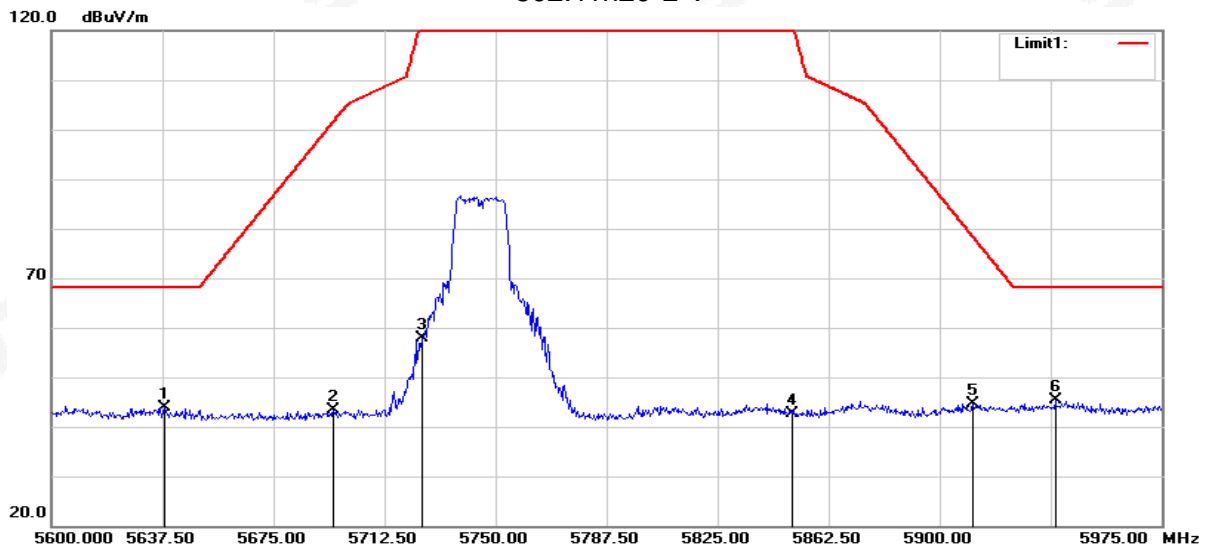

No.	Frequency (MHz)	Reading (dBuV)	Correct Factor(dB/m)	Result (dBuV/m)	Limit (dBuV/m)	Margin (dB)	Remark
1	5638.250	48.56	-4.69	43.87	68.20	-24.33	peak
2	5695.250	47.97	-4.66	43.31	101.69	-58.38	peak
3	5725.000	62.38	-4.57	57.81	122.20	-64.39	peak
4	5850.000	46.76	-4.10	42.66	122.20	-79.54	peak
5	5911.250	48.54	-3.90	44.64	78.38	-33.74	peak
6	5939.000	49.22	-3.95	45.27	68.20	-22.93	peak

802.11n20-H-H

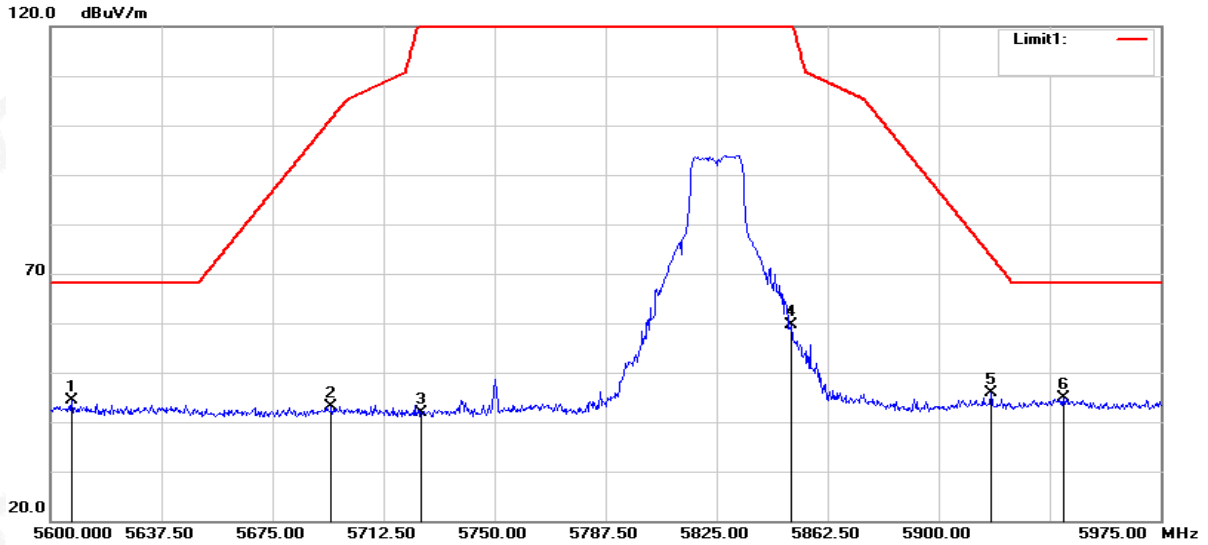

No.	Frequency (MHz)	Reading (dBuV)	Correct Factor(dB/m)	Result (dBuV/m)	Limit (dBuV/m)	Margin (dB)	Remark
1	5607.125	48.96	-4.70	44.26	68.20	-23.94	peak
2	5694.875	47.78	-4.66	43.12	101.41	-58.29	peak
3	5725.000	46.43	-4.57	41.86	122.20	-80.34	peak
4	5850.000	63.63	-4.10	59.53	122.20	-62.67	peak
5	5917.625	49.67	-3.91	45.76	73.66	-27.90	peak
6	5942.000	48.90	-3.95	44.95	68.20	-23.25	peak

802.11n20-H-V

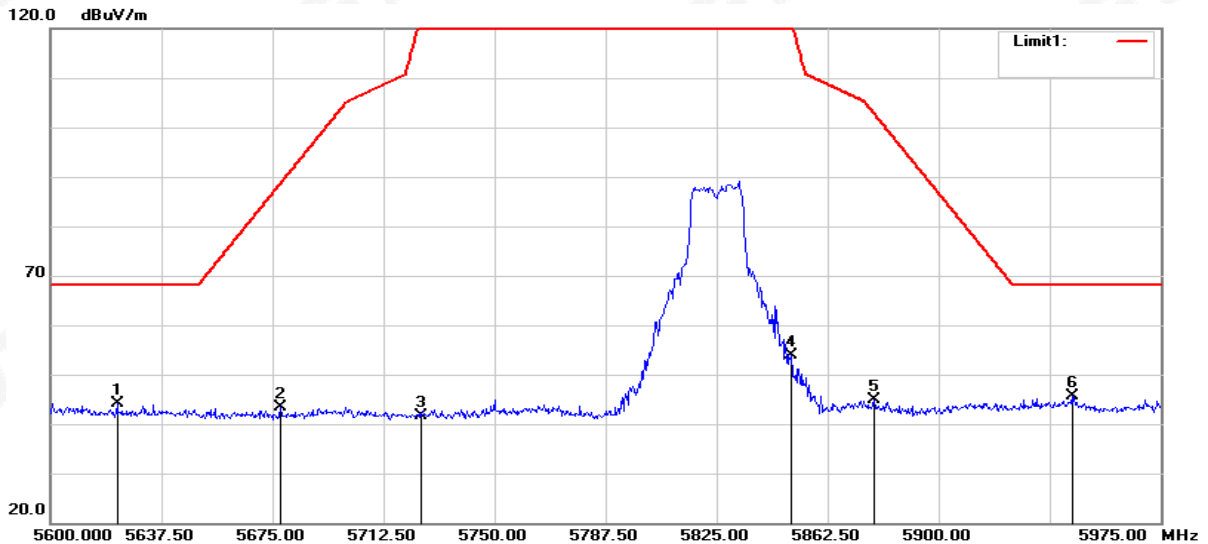

No.	Frequency (MHz)	Reading (dBuV)	Correct Factor(dB/m)	Result (dBuV/m)	Limit (dBuV/m)	Margin (dB)	Remark
1	5622.500	48.89	-4.69	44.20	68.20	-24.00	peak
2	5677.625	47.96	-4.67	43.29	88.64	-45.35	peak
3	5725.000	46.16	-4.57	41.59	122.20	-80.61	peak
4	5850.000	57.88	-4.10	53.78	122.20	-68.42	peak
5	5878.250	48.82	-3.97	44.85	102.80	-57.95	peak
6	5945.000	49.50	-3.96	45.54	68.20	-22.66	peak

802.11ac40-L-H

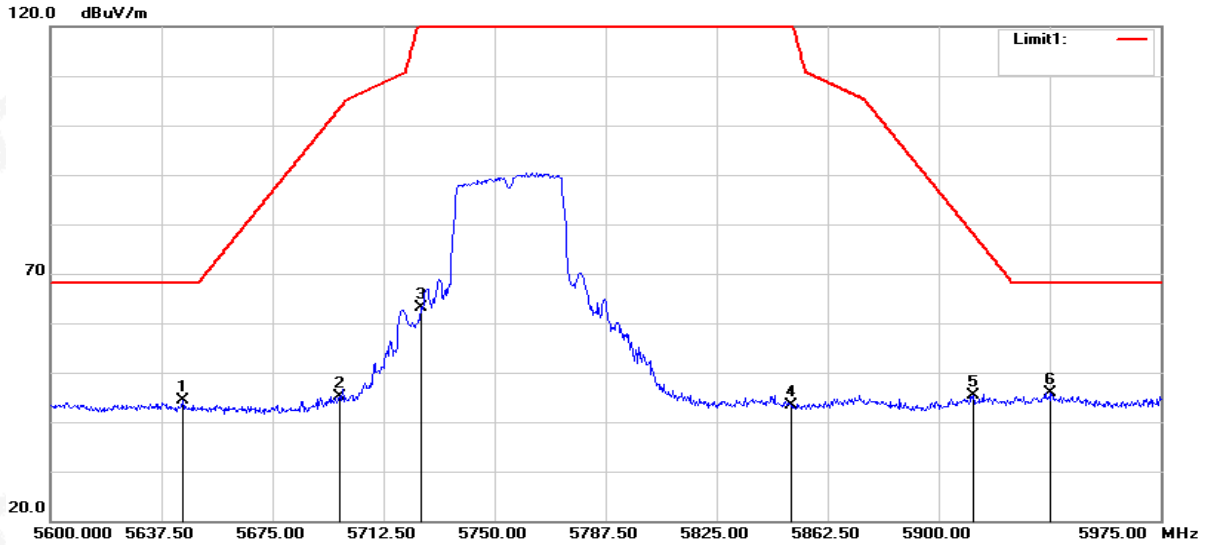

No.	Frequency (MHz)	Reading (dBuV)	Correct Factor(dB/m)	Result (dBuV/m)	Limit (dBuV/m)	Margin (dB)	Remark
1	5644.625	49.07	-4.68	44.39	68.20	-23.81	peak
2	5697.875	49.87	-4.66	45.21	103.63	-58.42	peak
3	5725.000	67.74	-4.57	63.17	122.20	-59.03	peak
4	5850.000	47.54	-4.10	43.44	122.20	-78.76	peak
5	5911.625	49.17	-3.90	45.27	78.10	-32.83	peak
6	5937.875	49.79	-3.94	45.85	68.20	-22.35	peak

802.11ac40-L-V

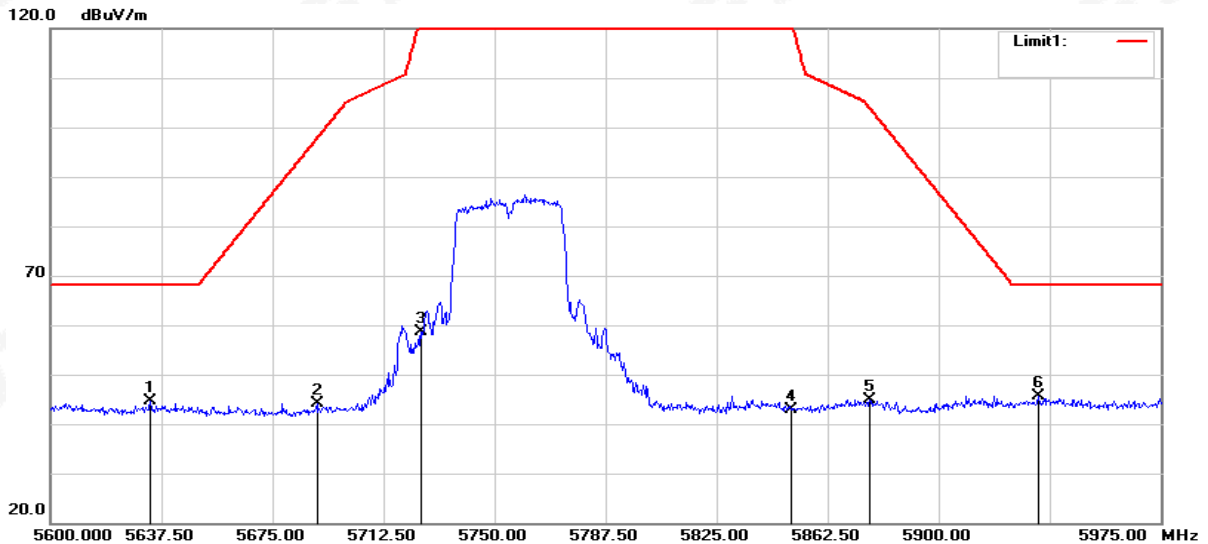

No.	Frequency (MHz)	Reading (dBuV)	Correct Factor(dB/m)	Result (dBuV/m)	Limit (dBuV/m)	Margin (dB)	Remark
1	5633.750	49.38	-4.69	44.69	68.20	-23.51	peak
2	5690.000	48.84	-4.67	44.17	97.80	-53.63	peak
3	5725.000	63.17	-4.57	58.60	122.20	-63.60	peak
4	5850.000	47.04	-4.10	42.94	122.20	-79.26	peak
5	5876.750	48.75	-3.99	44.76	103.91	-59.15	peak
6	5933.750	49.54	-3.94	45.60	68.20	-22.60	peak

802.11ac40-H-H

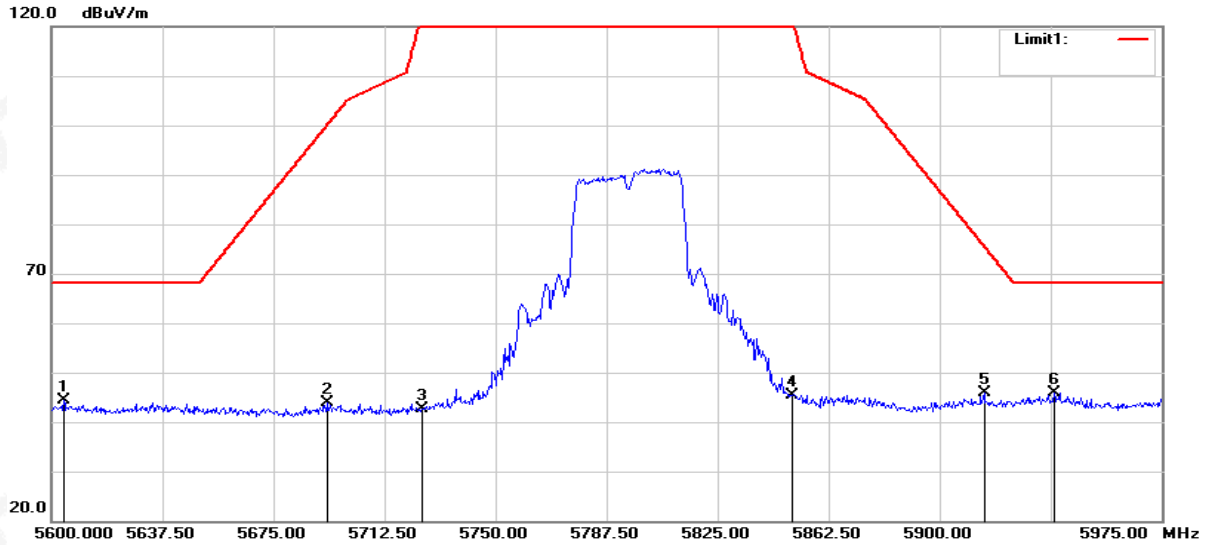

No.	Frequency (MHz)	Reading (dBuV)	Correct Factor(dB/m)	Result (dBuV/m)	Limit (dBuV/m)	Margin (dB)	Remark
1	5604.125	49.06	-4.69	44.37	68.20	-23.83	peak
2	5693.000	48.54	-4.66	43.88	100.02	-56.14	peak
3	5725.000	47.10	-4.57	42.53	122.20	-79.67	peak
4	5850.000	49.60	-4.10	45.50	122.20	-76.70	peak
5	5915.000	49.85	-3.91	45.94	75.60	-29.66	peak
6	5938.625	49.86	-3.95	45.91	68.20	-22.29	peak

802.11ac40-H-V

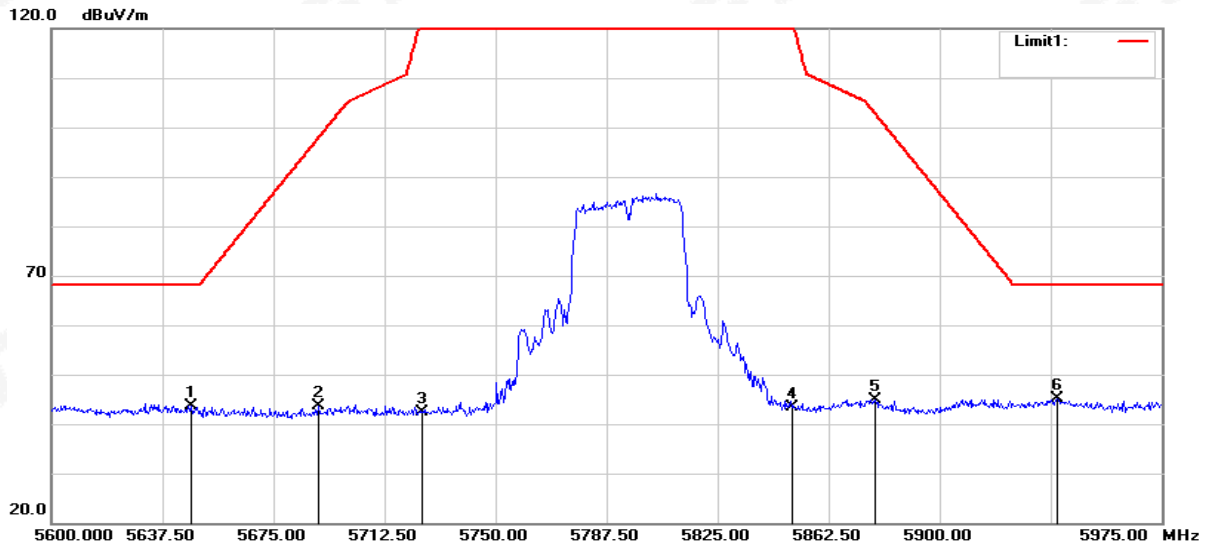

No.	Frequency (MHz)	Reading (dBuV)	Correct Factor(dB/m)	Result (dBuV/m)	Limit (dBuV/m)	Margin (dB)	Remark
1	5647.250	48.23	-4.68	43.55	68.20	-24.65	peak
2	5690.375	48.19	-4.67	43.52	98.08	-54.56	peak
3	5725.000	46.91	-4.57	42.34	122.20	-79.86	peak
4	5850.000	47.36	-4.10	43.26	122.20	-78.94	peak
5	5878.250	48.86	-3.97	44.89	102.80	-57.91	peak
6	5939.750	49.09	-3.95	45.14	68.20	-23.06	peak

802.11ac80-H

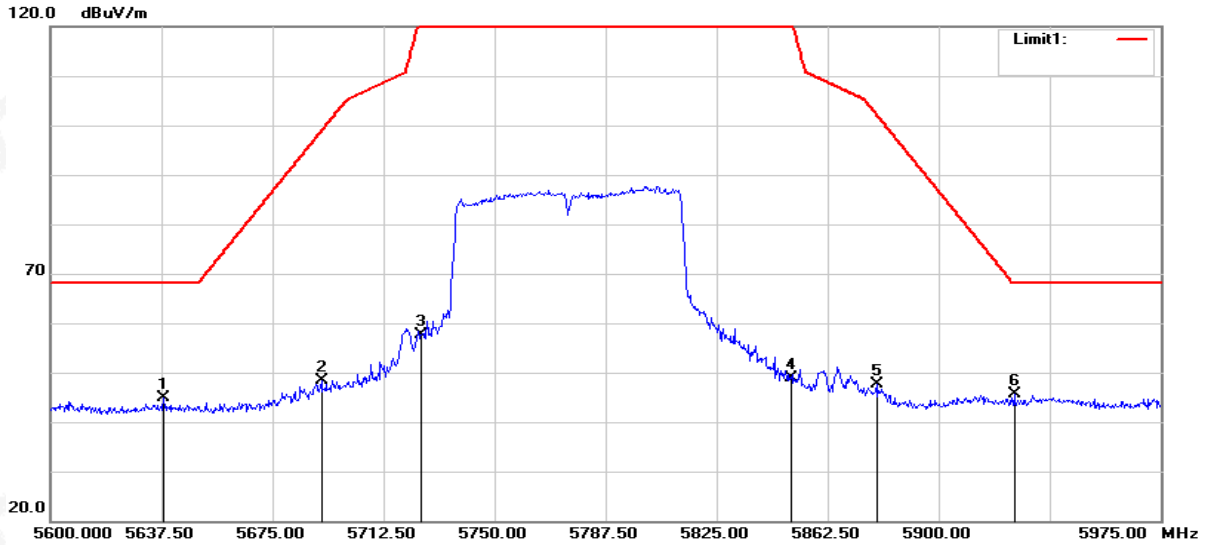

No.	Frequency (MHz)	Reading (dBuV)	Correct Factor(dB/m)	Result (dBuV/m)	Limit (dBuV/m)	Margin (dB)	Remark
1	5638.250	49.62	-4.69	44.93	68.20	-23.27	peak
2	5691.500	53.07	-4.66	48.41	98.91	-50.50	peak
3	5725.000	62.09	-4.57	57.52	122.20	-64.68	peak
4	5850.000	52.95	-4.10	48.85	122.20	-73.35	peak
5	5879.000	51.64	-3.97	47.67	102.24	-54.57	peak
6	5925.500	49.66	-3.92	45.74	68.20	-22.46	peak

802.11ac80-V

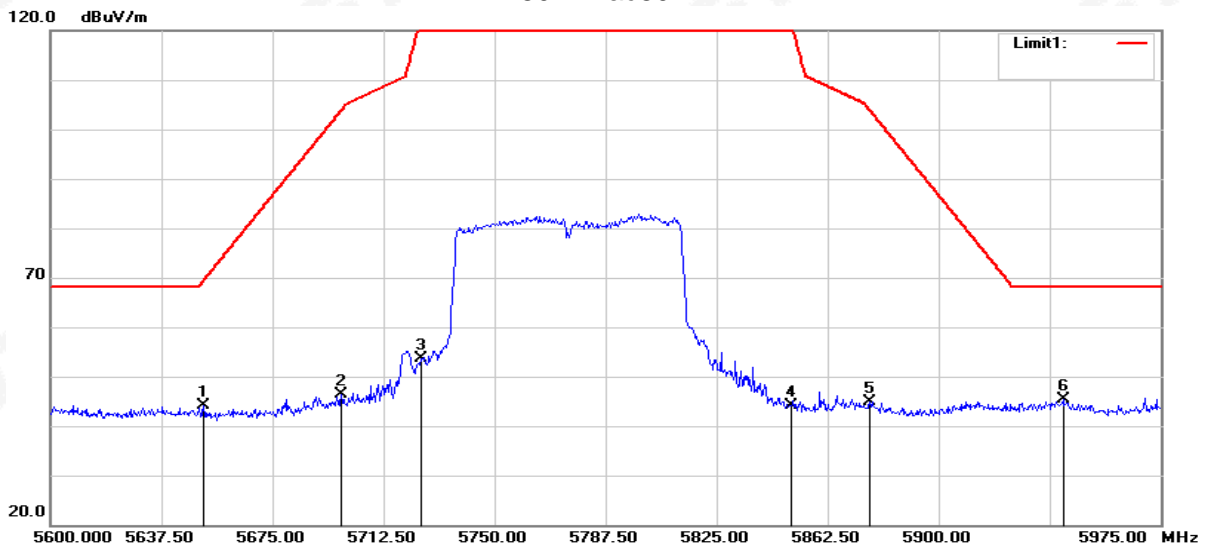

No.	Frequency (MHz)	Reading (dBuV)	Correct Factor(dB/m)	Result (dBuV/m)	Limit (dBuV/m)	Margin (dB)	Remark
1	5651.750	48.85	-4.68	44.17	69.50	-25.33	peak
2	5698.250	51.16	-4.66	46.50	103.91	-57.41	peak
3	5725.000	58.19	-4.57	53.62	122.20	-68.58	peak
4	5850.000	48.27	-4.10	44.17	122.20	-78.03	peak
5	5876.750	48.94	-3.99	44.95	103.91	-58.96	peak
6	5942.000	49.43	-3.95	45.48	68.20	-22.72	peak

Note: All modes have been tested. Only the worst mode shown in the report.

MOX 2

U-NII-1 5150-5250MHz

802.11a20-L-H

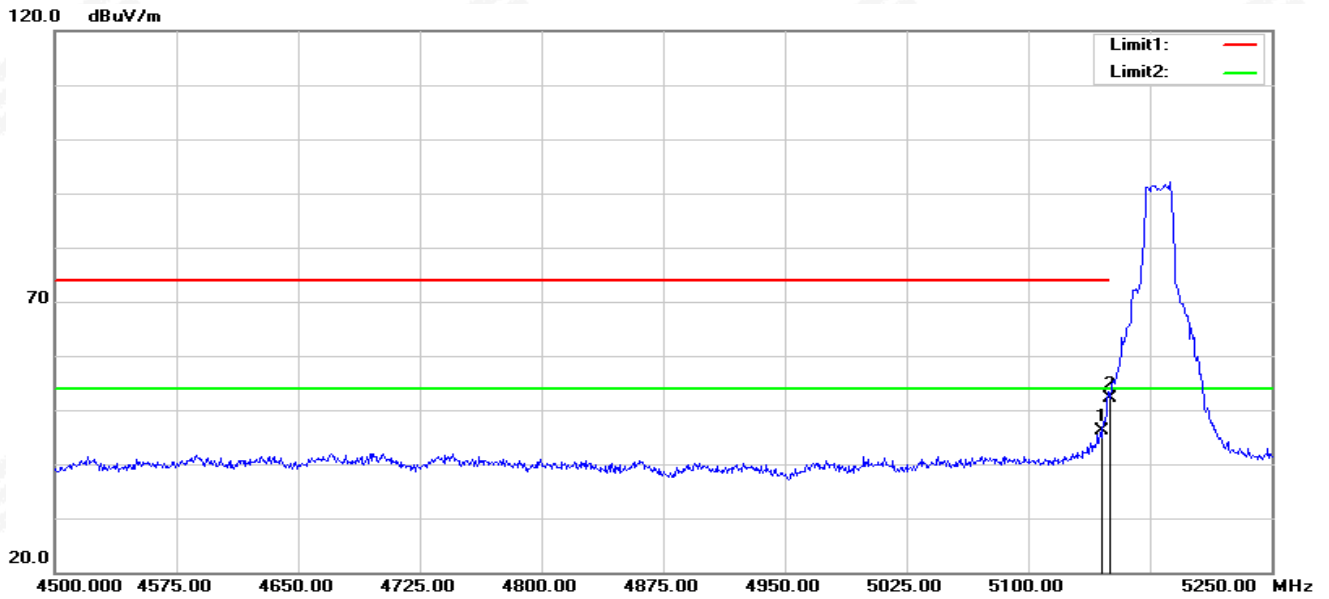

No.	Frequency (MHz)	Reading (dBuV)	Correct Factor(dB/m)	Result (dBuV/m)	Limit (dBuV/m)	Margin (dB)	Remark
1	5145.750	51.74	-5.73	46.01	74.00	-27.99	peak
2	5150.000	57.82	-5.73	52.09	74.00	-21.91	peak

802.11a20-L-V

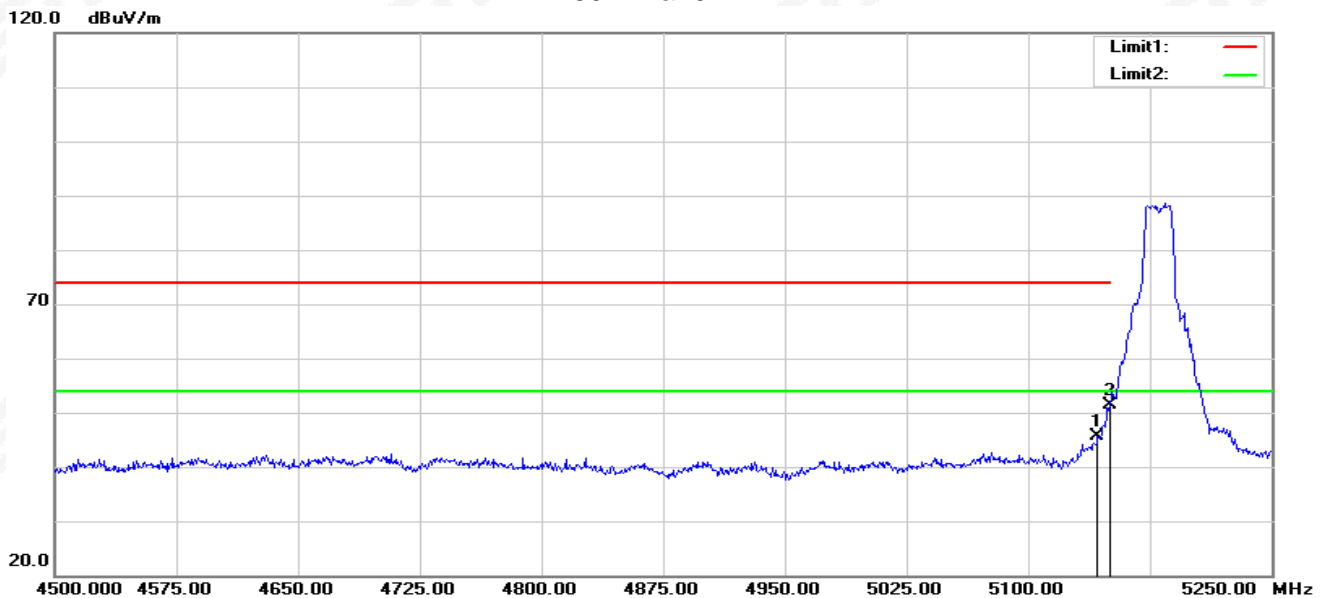

No.	Frequency (MHz)	Reading (dBuV)	Correct Factor(dB/m)	Result (dBuV/m)	Limit (dBuV/m)	Margin (dB)	Remark
1	5142.750	51.28	-5.74	45.54	74.00	-28.46	peak
2	5150.000	57.22	-5.73	51.49	74.00	-22.51	peak



802.11a20-H-H

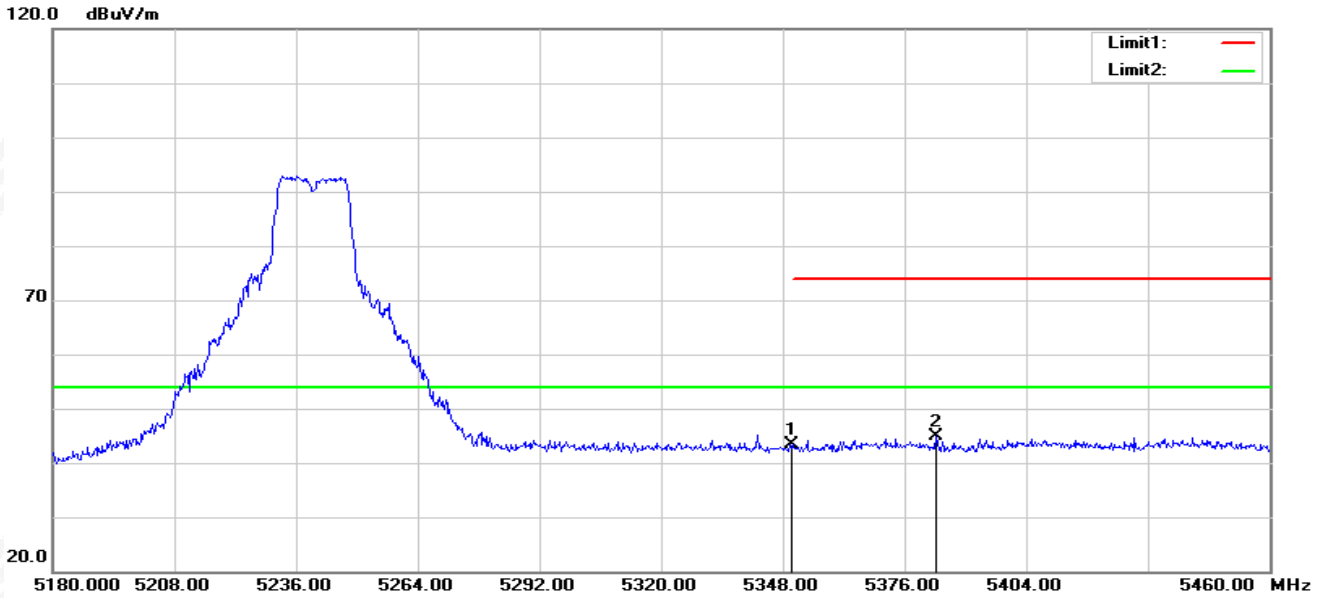

No.	Frequency (MHz)	Reading (dBuV)	Correct Factor(dB/m)	Result (dBuV/m)	Limit (dBuV/m)	Margin (dB)	Remark
1	5350.000	48.49	-5.23	43.26	74.00	-30.74	peak
2	5383.280	50.21	-5.24	44.97	74.00	-29.03	peak

802.11a20-H-V

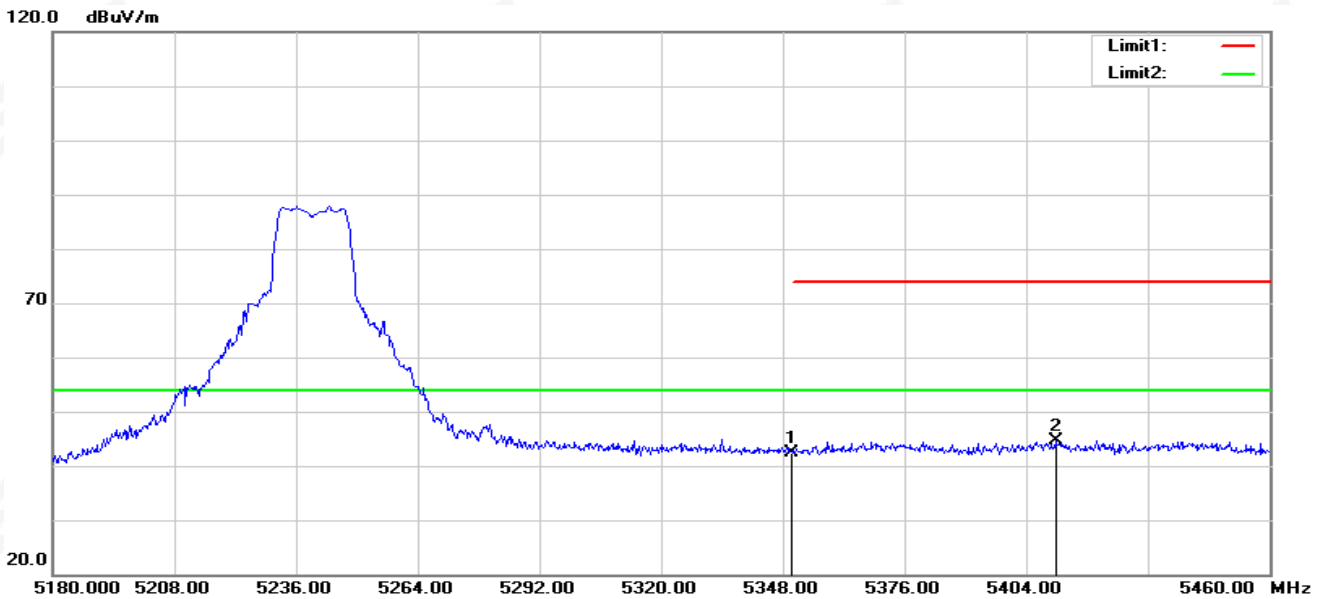

No.	Frequency (MHz)	Reading (dBuV)	Correct Factor(dB/m)	Result (dBuV/m)	Limit (dBuV/m)	Margin (dB)	Remark
1	5350.000	47.72	-5.23	42.49	74.00	-31.51	peak
2	5410.720	49.90	-5.22	44.68	74.00	-29.32	peak



802.11ac40-L-H

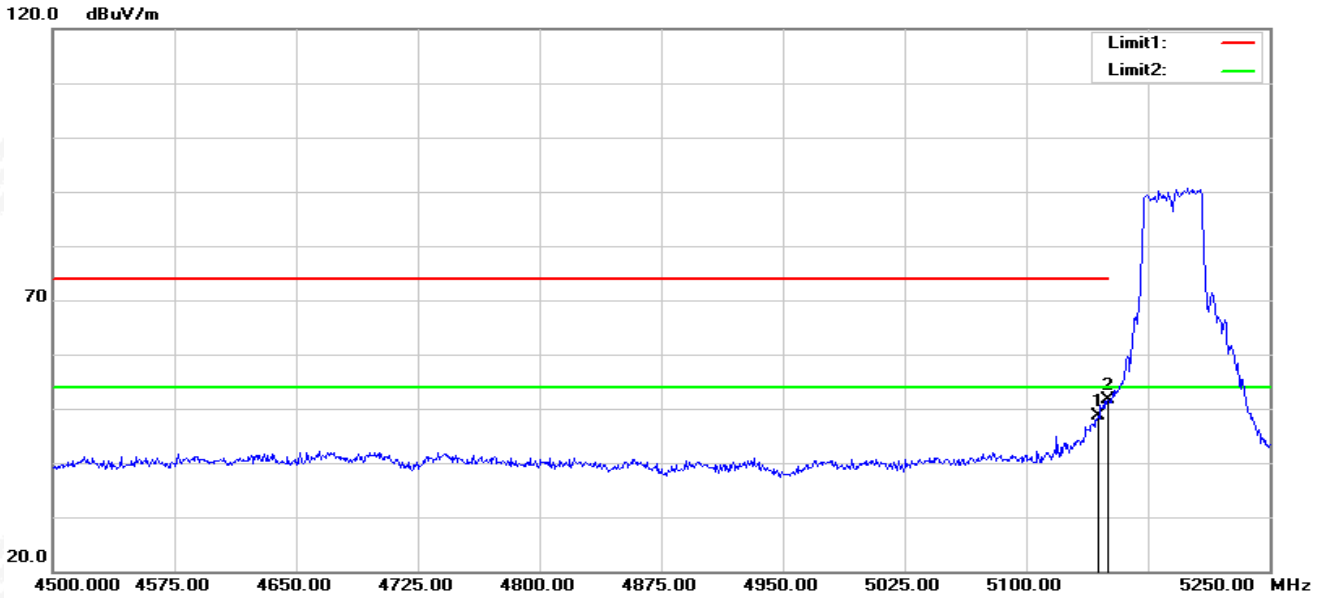

No.	Frequency (MHz)	Reading (dBuV)	Correct Factor(dB/m)	Result (dBuV/m)	Limit (dBuV/m)	Margin (dB)	Remark
1	5144.250	54.29	-5.73	48.56	74.00	-25.44	peak
2	5150.000	57.34	-5.73	51.61	74.00	-22.39	peak

802.11ac40-L-V

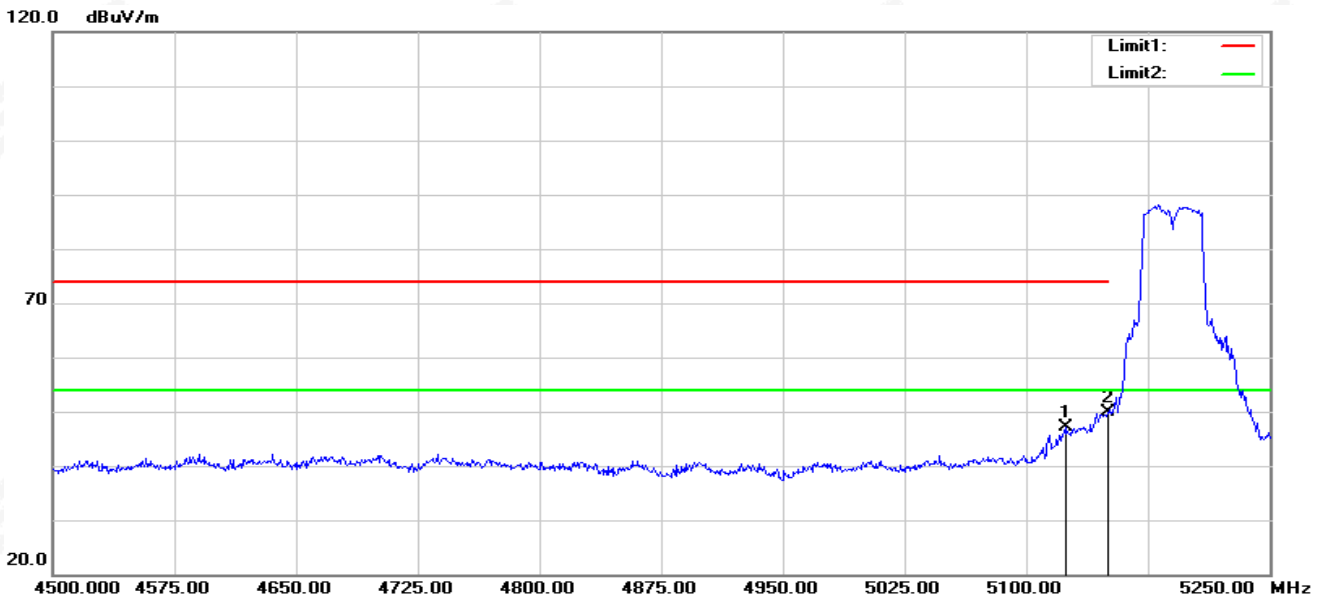

No.	Frequency (MHz)	Reading (dBuV)	Correct Factor(dB/m)	Result (dBuV/m)	Limit (dBuV/m)	Margin (dB)	Remark
1	5124.750	52.84	-5.74	47.10	74.00	-26.90	peak
2	5150.000	55.49	-5.73	49.76	74.00	-24.24	peak



802.11ac40-H-H

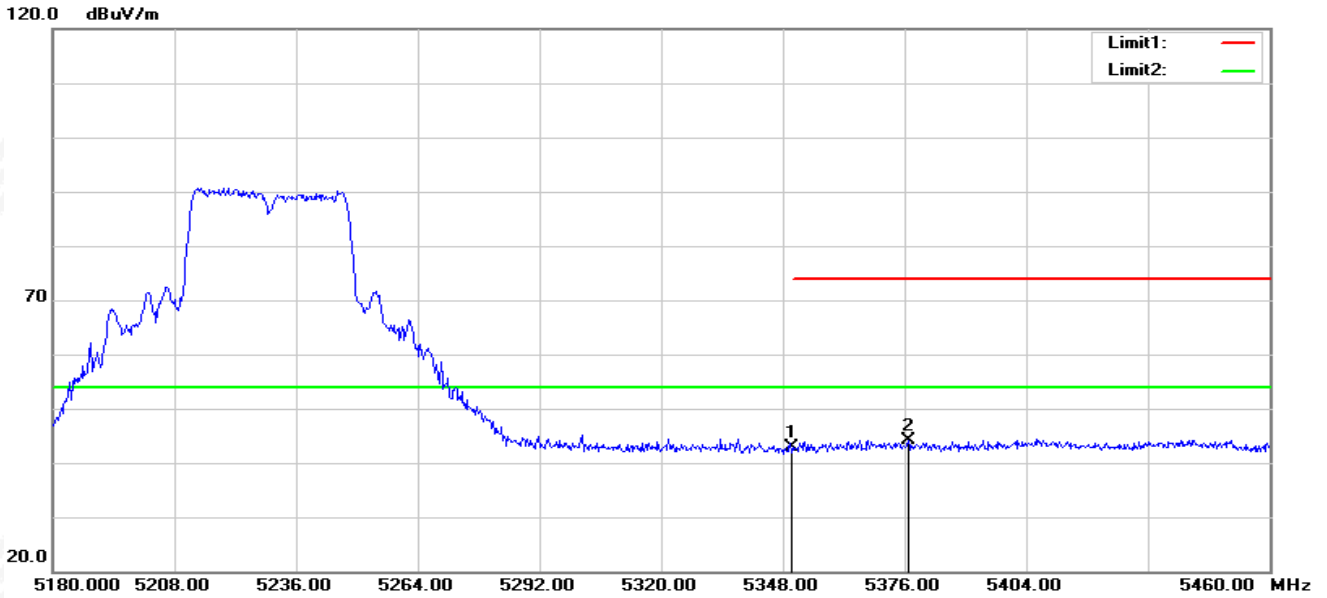

No.	Frequency (MHz)	Reading (dBuV)	Correct Factor(dB/m)	Result (dBuV/m)	Limit (dBuV/m)	Margin (dB)	Remark
1	5350.000	48.01	-5.23	42.78	74.00	-31.22	peak
2	5376.840	49.36	-5.24	44.12	74.00	-29.88	peak

802.11ac40-H-V

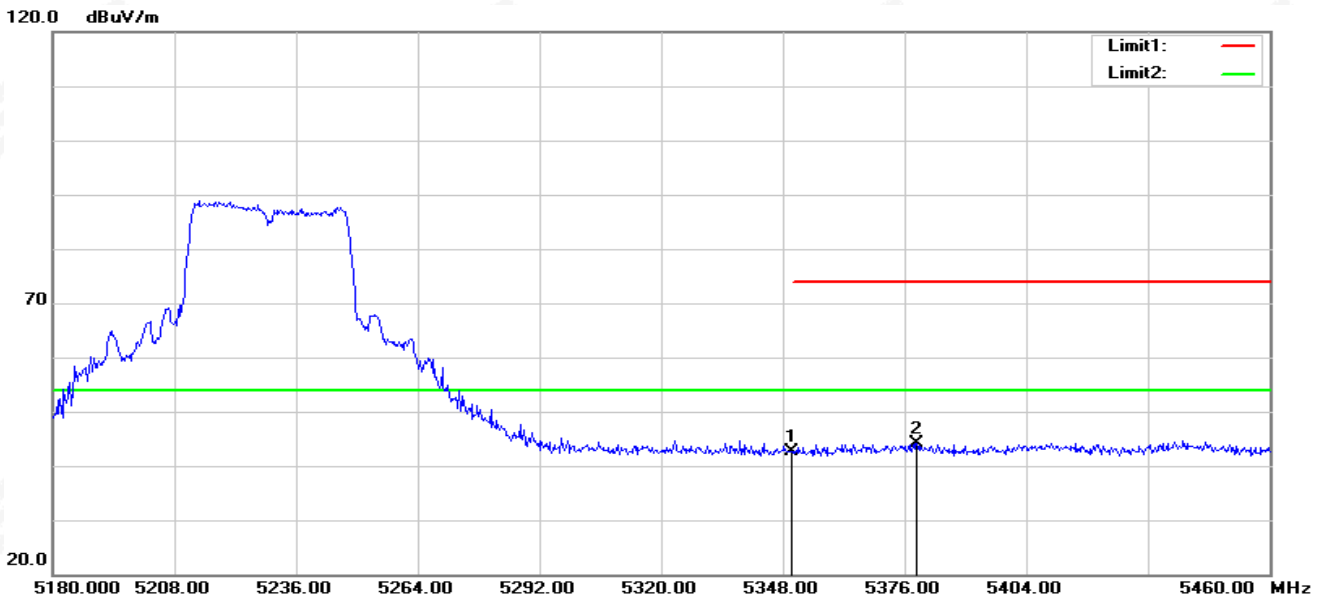

No.	Frequency (MHz)	Reading (dBuV)	Correct Factor(dB/m)	Result (dBuV/m)	Limit (dBuV/m)	Margin (dB)	Remark
1	5350.000	47.87	-5.23	42.64	74.00	-31.36	peak
2	5378.800	49.48	-5.24	44.24	74.00	-29.76	peak



802.11ac80-L-H

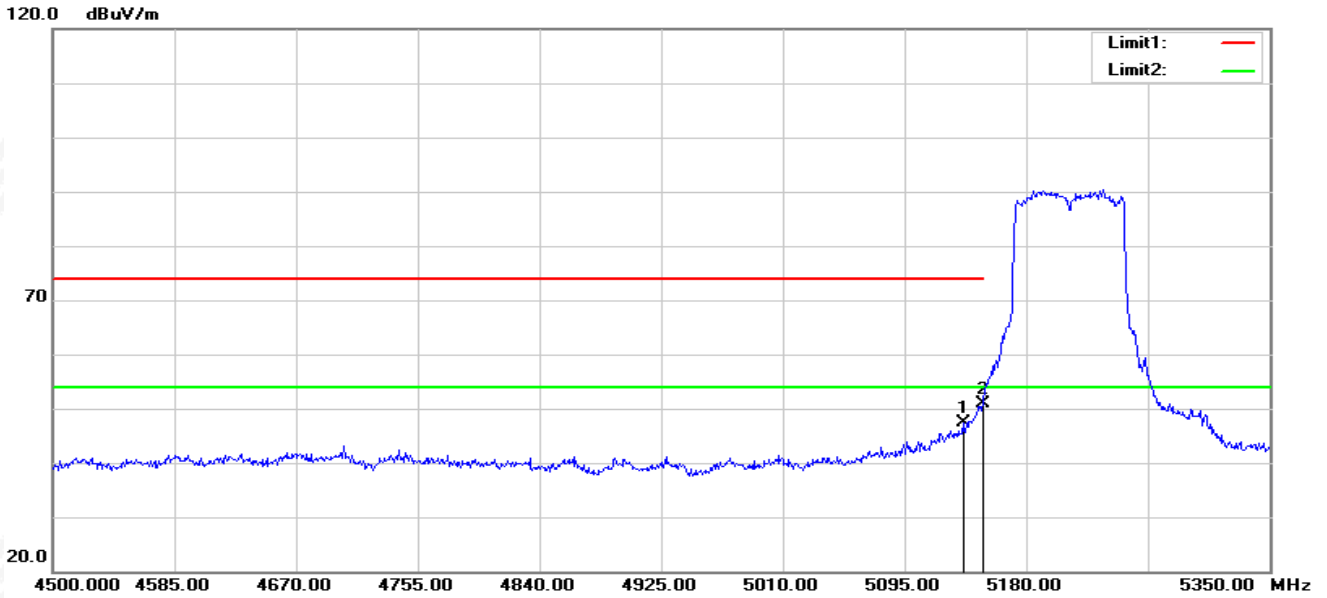

No.	Frequency (MHz)	Reading (dBuV)	Correct Factor(dB/m)	Result (dBuV/m)	Limit (dBuV/m)	Margin (dB)	Remark
1	5135.800	53.07	-5.74	47.33	74.00	-26.67	peak
2	5150.000	56.70	-5.73	50.97	74.00	-23.03	peak

802.11ac80-L-V

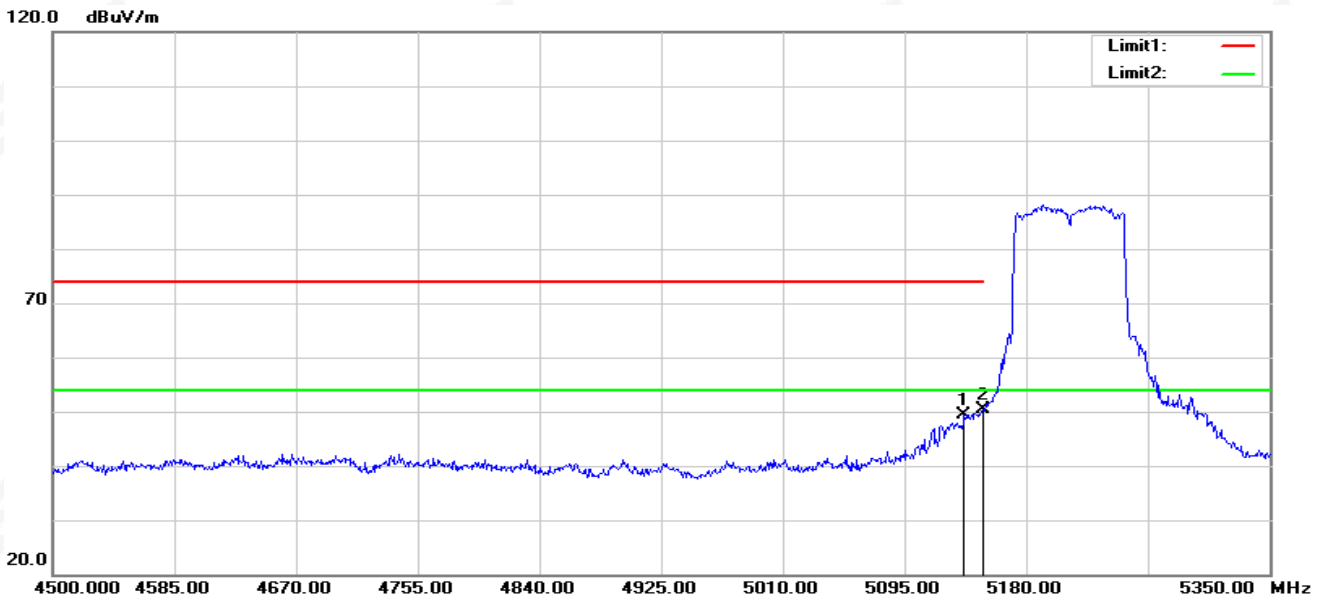

No.	Frequency (MHz)	Reading (dBuV)	Correct Factor(dB/m)	Result (dBuV/m)	Limit (dBuV/m)	Margin (dB)	Remark
1	5136.650	55.17	-5.74	49.43	74.00	-24.57	peak
2	5150.000	56.07	-5.73	50.34	74.00	-23.66	peak



802.11ac80-H-H

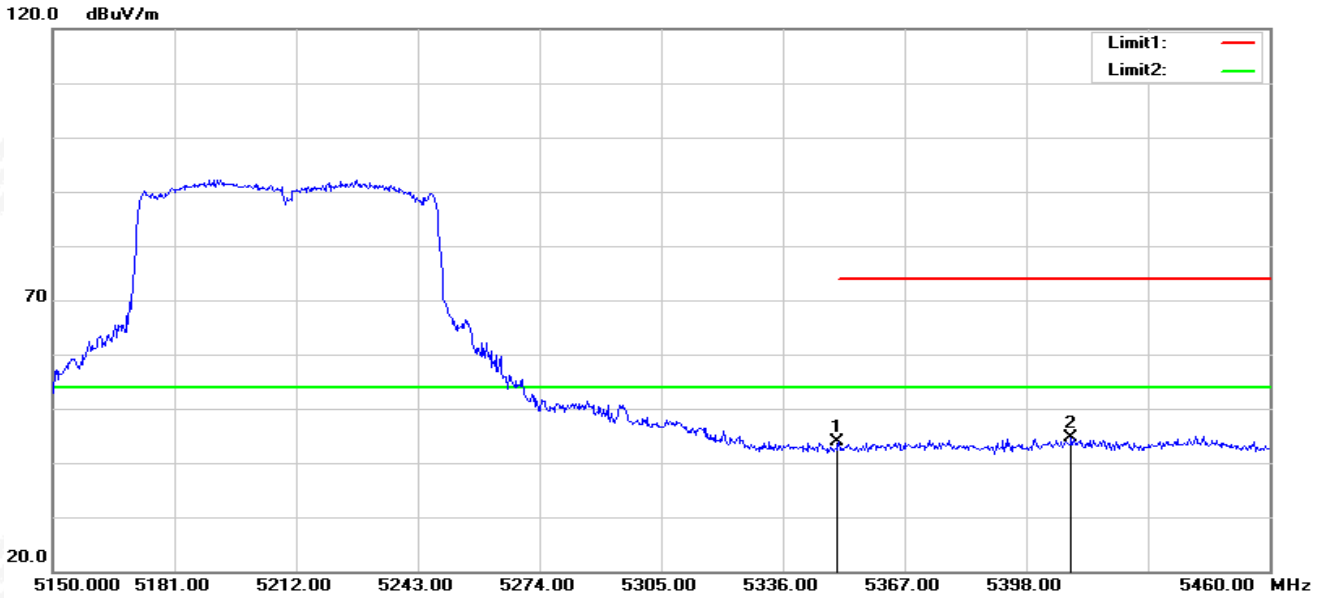

No.	Frequency (MHz)	Reading (dBuV)	Correct Factor(dB/m)	Result (dBuV/m)	Limit (dBuV/m)	Margin (dB)	Remark
1	5350.000	49.19	-5.23	43.96	74.00	-30.04	peak
2	5409.470	49.91	-5.23	44.68	74.00	-29.32	peak

802.11ac80-H-V

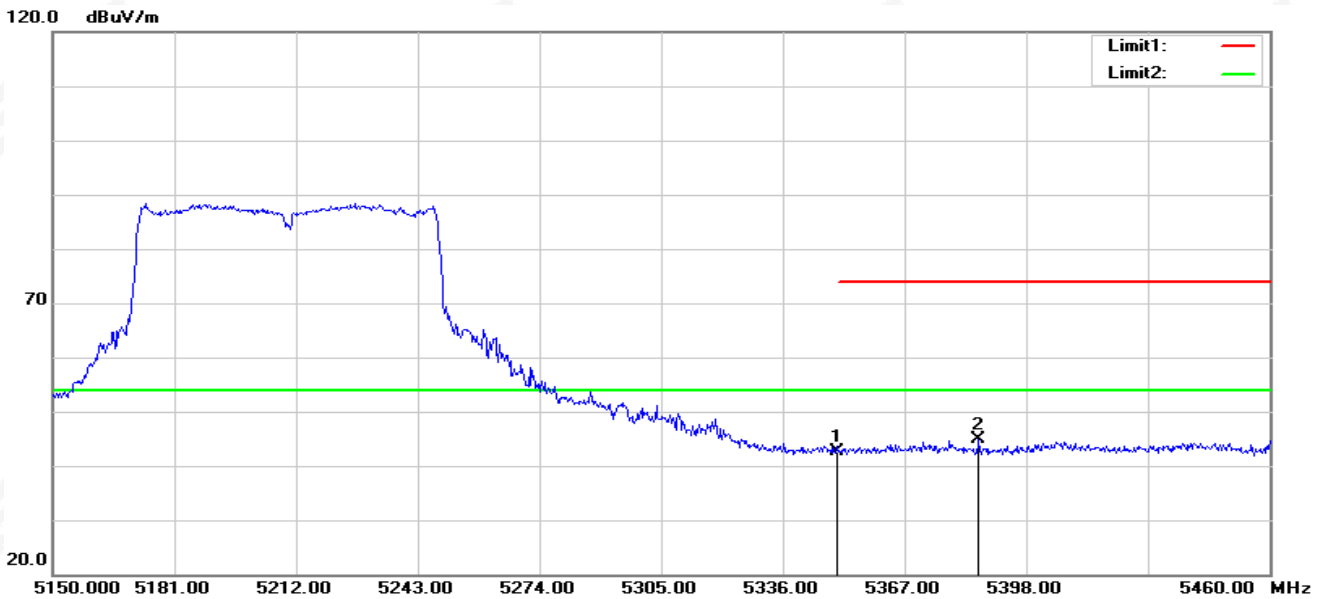

No.	Frequency (MHz)	Reading (dBuV)	Correct Factor(dB/m)	Result (dBuV/m)	Limit (dBuV/m)	Margin (dB)	Remark
1	5350.000	47.76	-5.23	42.53	74.00	-31.47	peak
2	5385.910	50.22	-5.24	44.98	74.00	-29.02	peak

Note: All modes have been tested. Only the worst mode shown in the report.

U-NII-2A 5250-5350MHz

802.11a20-L-H

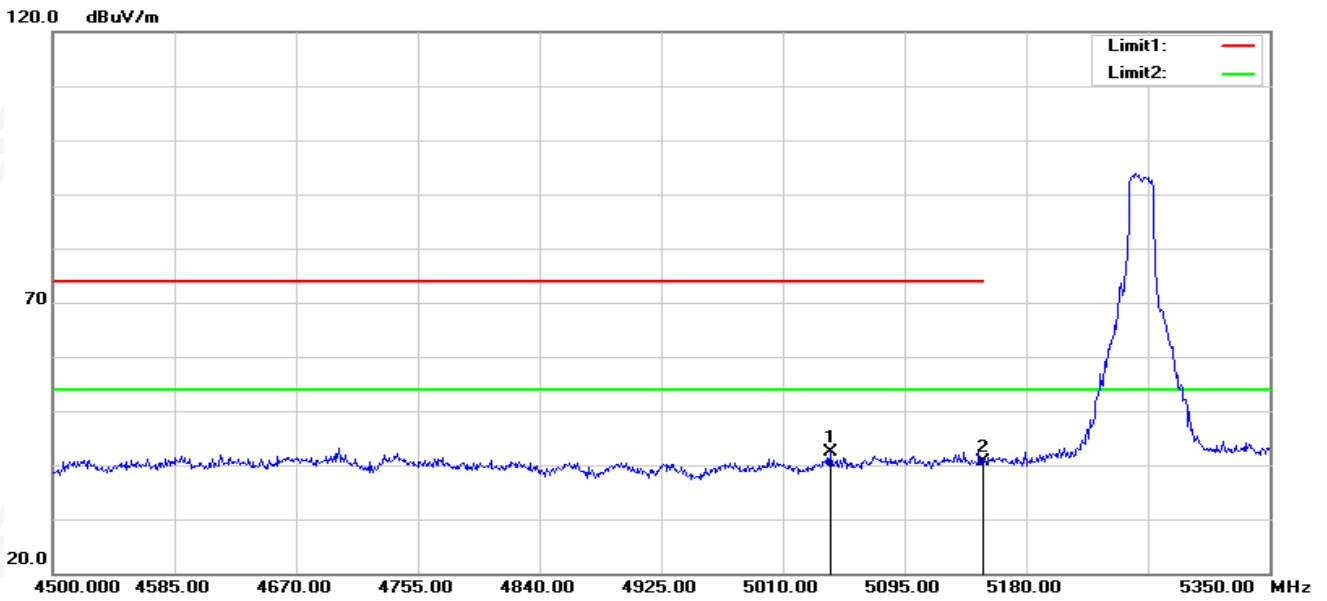

No.	Frequency (MHz)	Reading (dBuV)	Correct Factor(dB/m)	Result (dBuV/m)	Limit (dBuV/m)	Margin (dB)	Remark
1	5043.150	48.27	-6.00	42.27	74.00	-31.73	peak
2	5150.000	46.34	-5.73	40.61	74.00	-33.39	peak

802.11a20-L-V

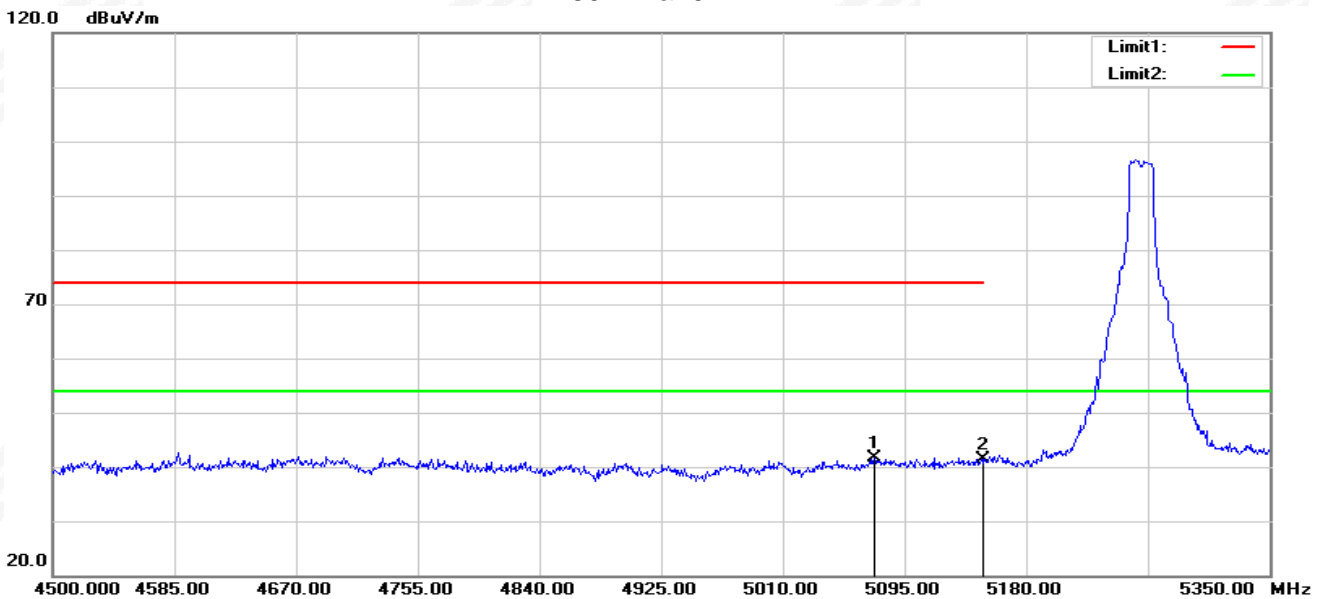

No.	Frequency (MHz)	Reading (dBuV)	Correct Factor(dB/m)	Result (dBuV/m)	Limit (dBuV/m)	Margin (dB)	Remark
1	5073.750	47.56	-5.86	41.70	74.00	-32.30	peak
2	5150.000	47.09	-5.73	41.36	74.00	-32.64	peak



802.11a20-H-H

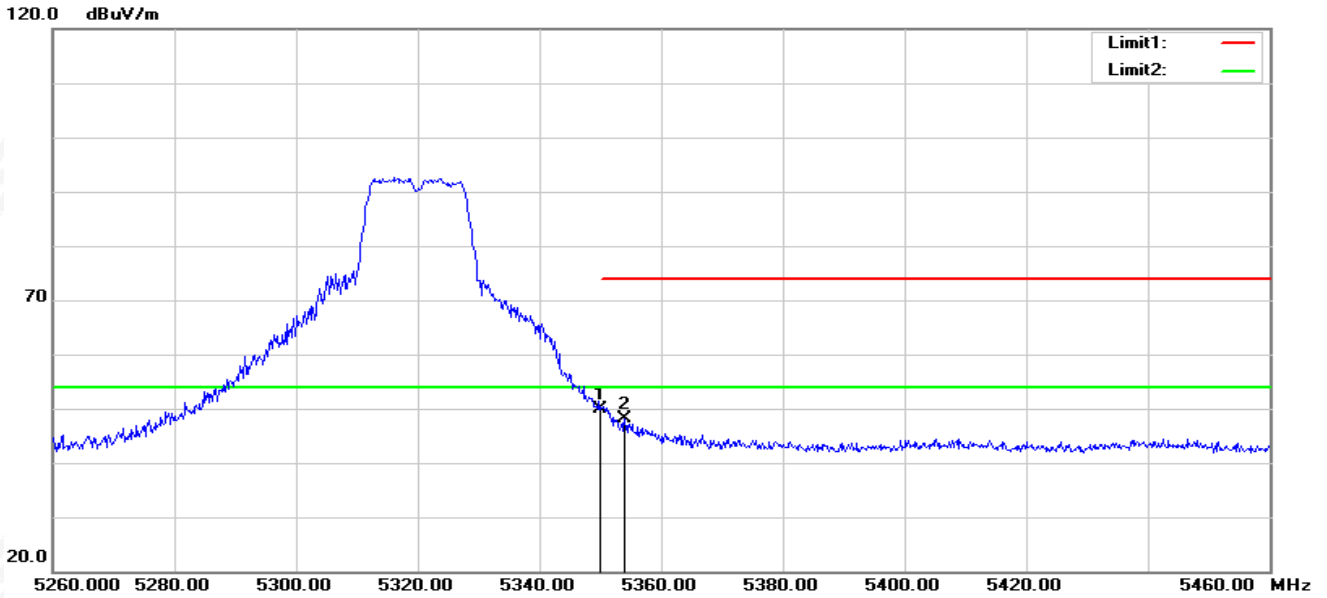

No.	Frequency (MHz)	Reading (dBuV)	Correct Factor(dB/m)	Result (dBuV/m)	Limit (dBuV/m)	Margin (dB)	Remark
1	5350.000	55.07	-5.23	49.84	74.00	-24.16	peak
2	5354.000	53.28	-5.23	48.05	74.00	-25.95	peak

802.11a20-H-V

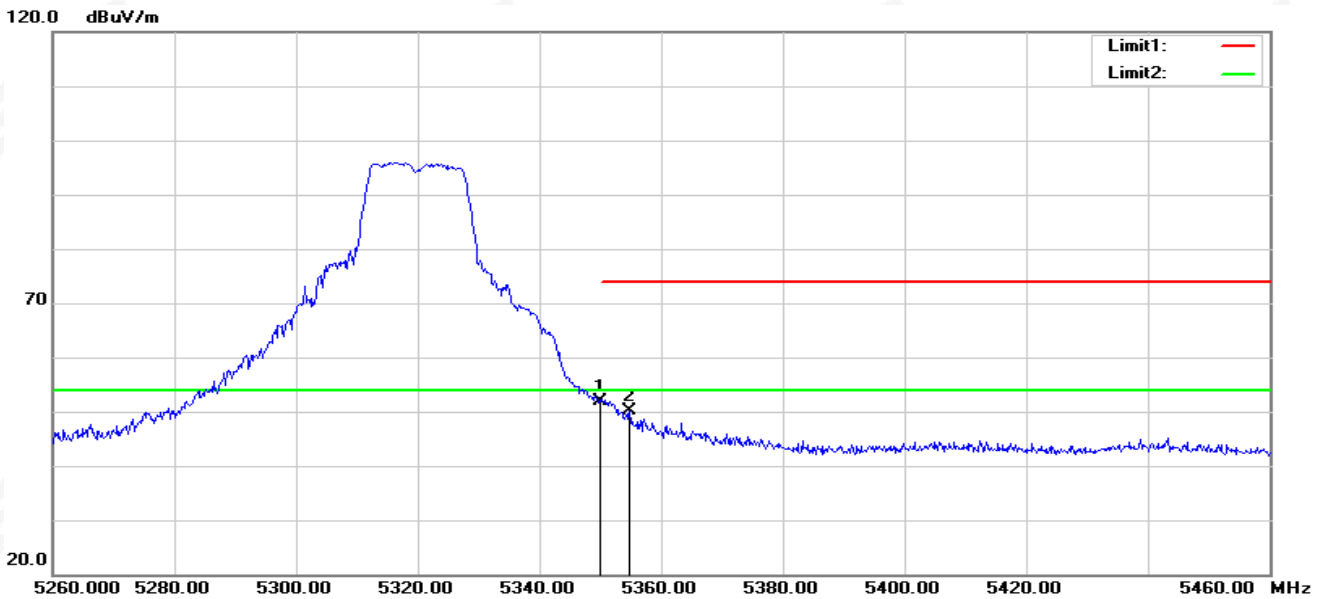

No.	Frequency (MHz)	Reading (dBuV)	Correct Factor(dB/m)	Result (dBuV/m)	Limit (dBuV/m)	Margin (dB)	Remark
1	5350.000	57.03	-5.23	51.80	74.00	-22.20	peak
2	5354.800	55.37	-5.24	50.13	74.00	-23.87	peak



802.11ac40-L-H

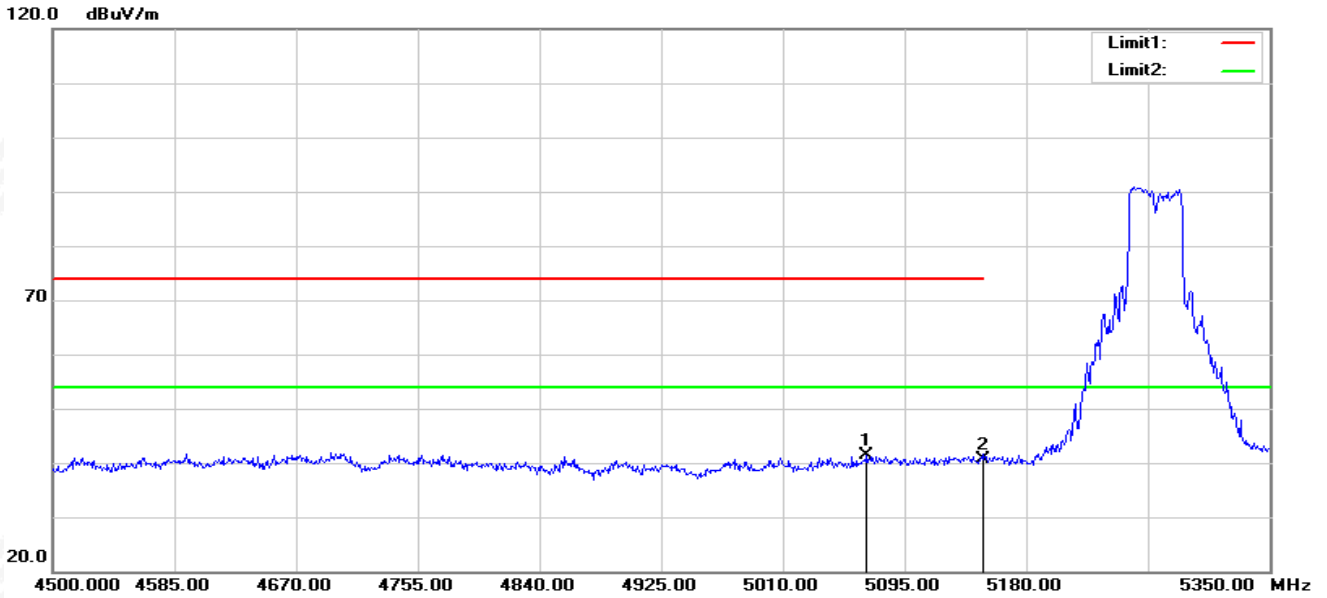

No.	Frequency (MHz)	Reading (dBuV)	Correct Factor(dB/m)	Result (dBuV/m)	Limit (dBuV/m)	Margin (dB)	Remark
1	5068.650	47.17	-5.89	41.28	74.00	-32.72	peak
2	5150.000	46.39	-5.73	40.66	74.00	-33.34	peak

802.11ac40-L-V

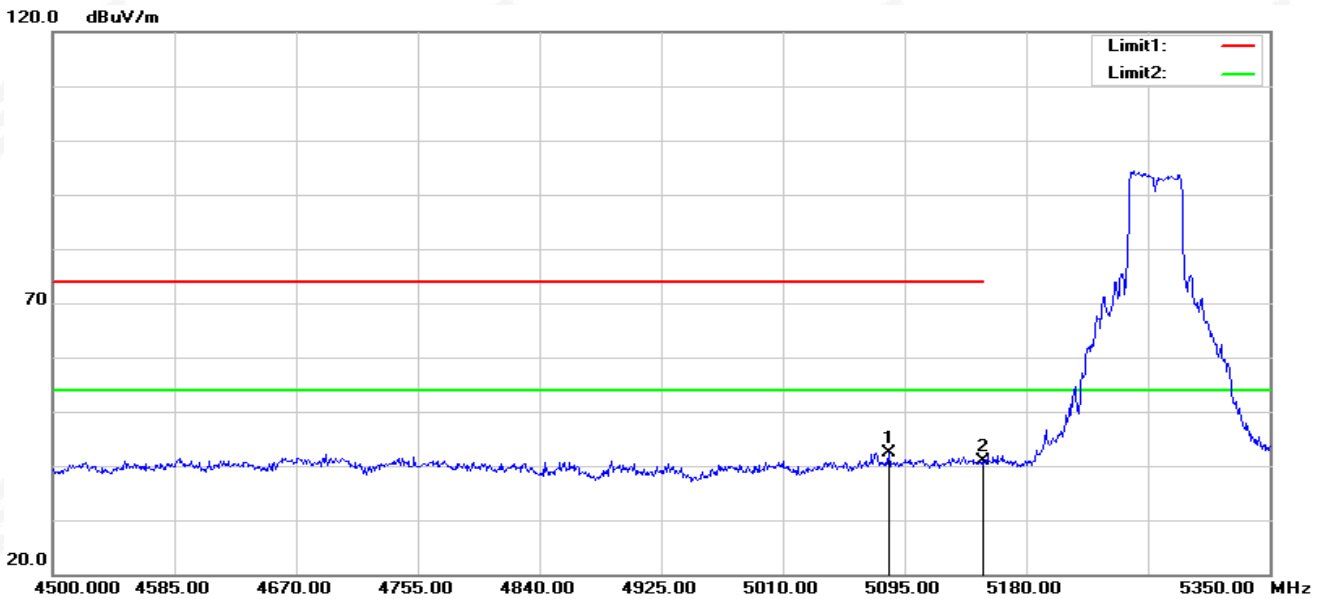

No.	Frequency (MHz)	Reading (dBuV)	Correct Factor(dB/m)	Result (dBuV/m)	Limit (dBuV/m)	Margin (dB)	Remark
1	5083.950	48.27	-5.81	42.46	74.00	-31.54	peak
2	5150.000	46.53	-5.73	40.80	74.00	-33.20	peak



802.11ac40-H-H

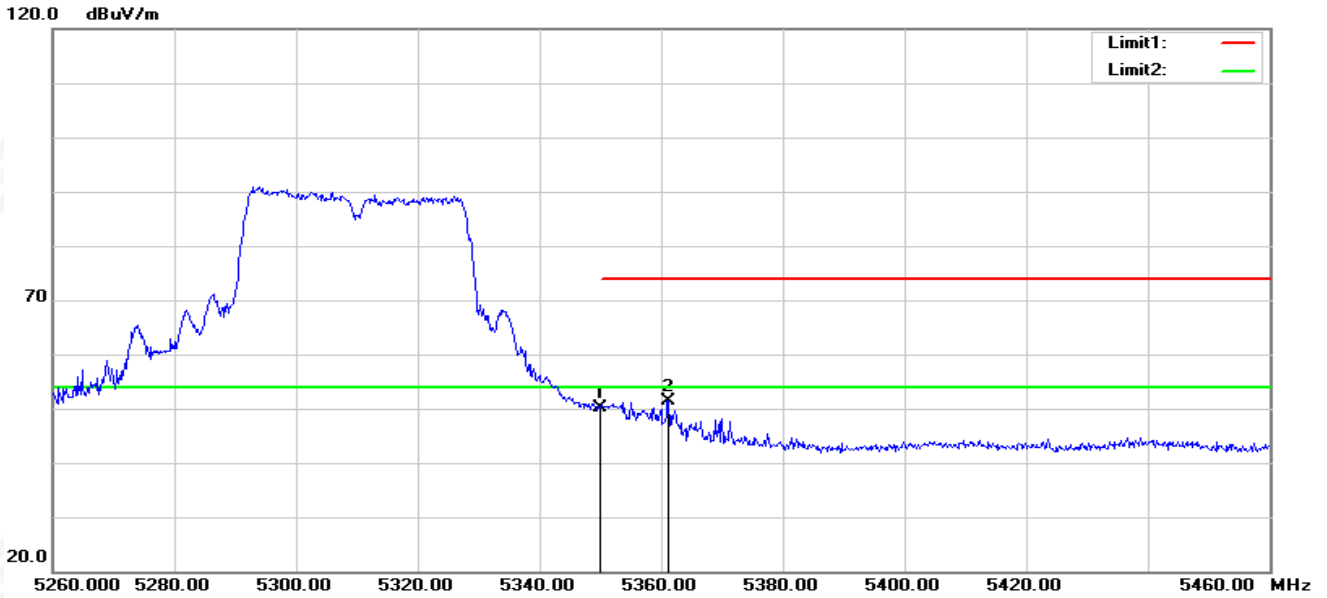

No.	Frequency (MHz)	Reading (dBuV)	Correct Factor(dB/m)	Result (dBuV/m)	Limit (dBuV/m)	Margin (dB)	Remark
1	5350.000	55.26	-5.23	50.03	74.00	-23.97	peak
2	5361.200	56.51	-5.23	51.28	74.00	-22.72	peak

802.11ac40-H-V

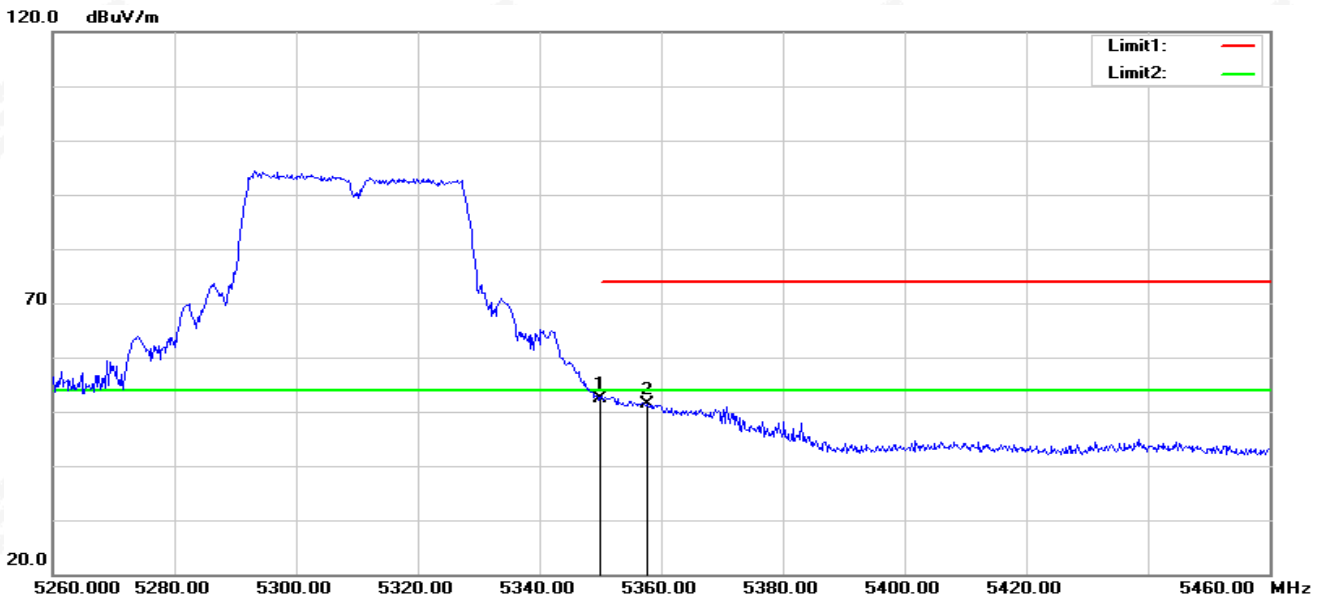

No.	Frequency (MHz)	Reading (dBuV)	Correct Factor(dB/m)	Result (dBuV/m)	Limit (dBuV/m)	Margin (dB)	Remark
1	5350.000	57.56	-5.23	52.33	74.00	-21.67	peak
2	5357.600	56.56	-5.23	51.33	74.00	-22.67	peak



802.11ac80-L-H

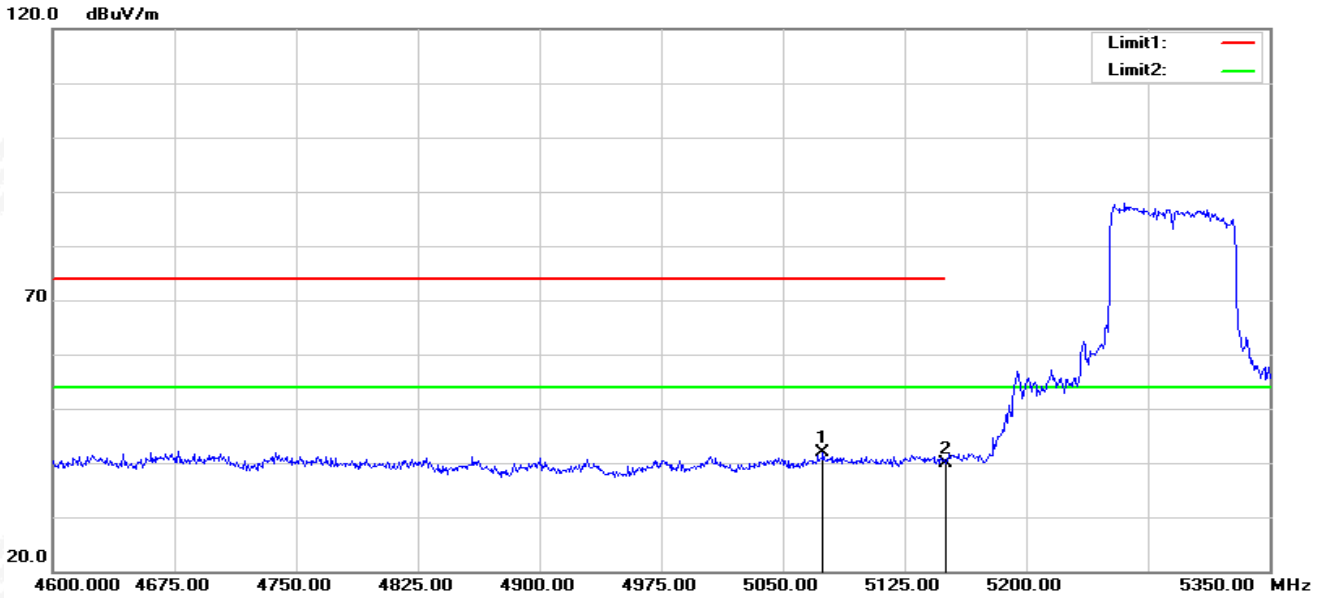

No.	Frequency (MHz)	Reading (dBuV)	Correct Factor(dB/m)	Result (dBuV/m)	Limit (dBuV/m)	Margin (dB)	Remark
1	5074.750	47.78	-5.85	41.93	74.00	-32.07	peak
2	5150.000	45.70	-5.73	39.97	74.00	-34.03	peak

802.11ac80-L-V

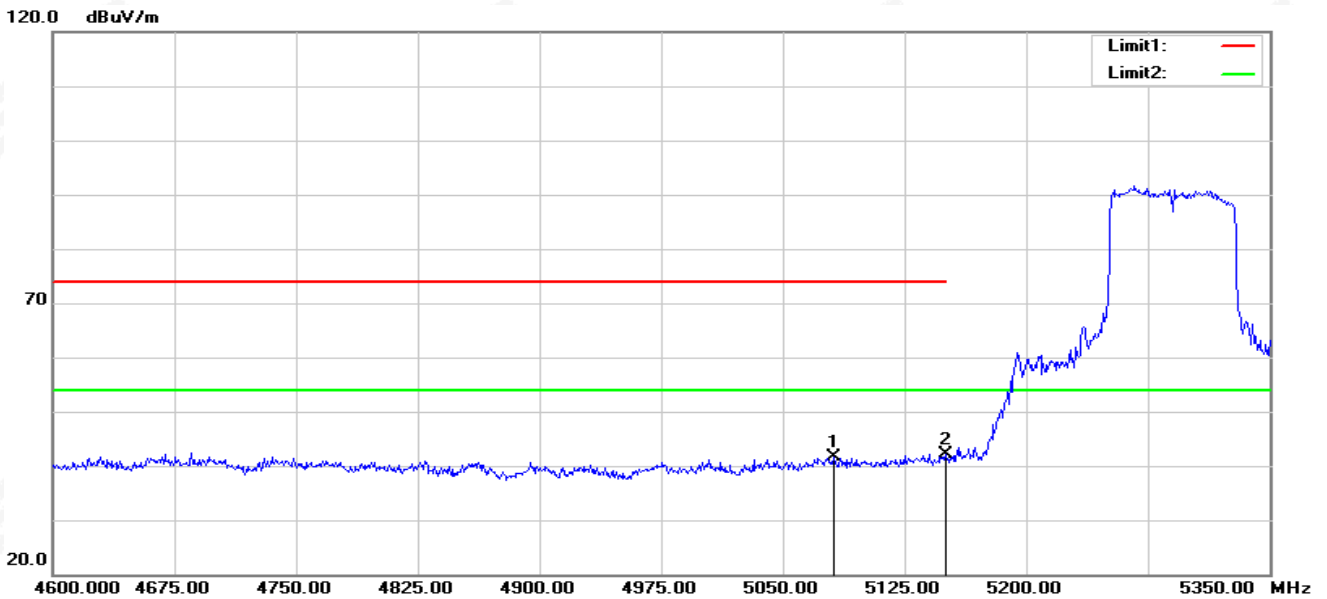

No.	Frequency (MHz)	Reading (dBuV)	Correct Factor(dB/m)	Result (dBuV/m)	Limit (dBuV/m)	Margin (dB)	Remark
1	5081.500	47.46	-5.82	41.64	74.00	-32.36	peak
2	5150.000	47.98	-5.73	42.25	74.00	-31.75	peak



802.11ac80-H-H

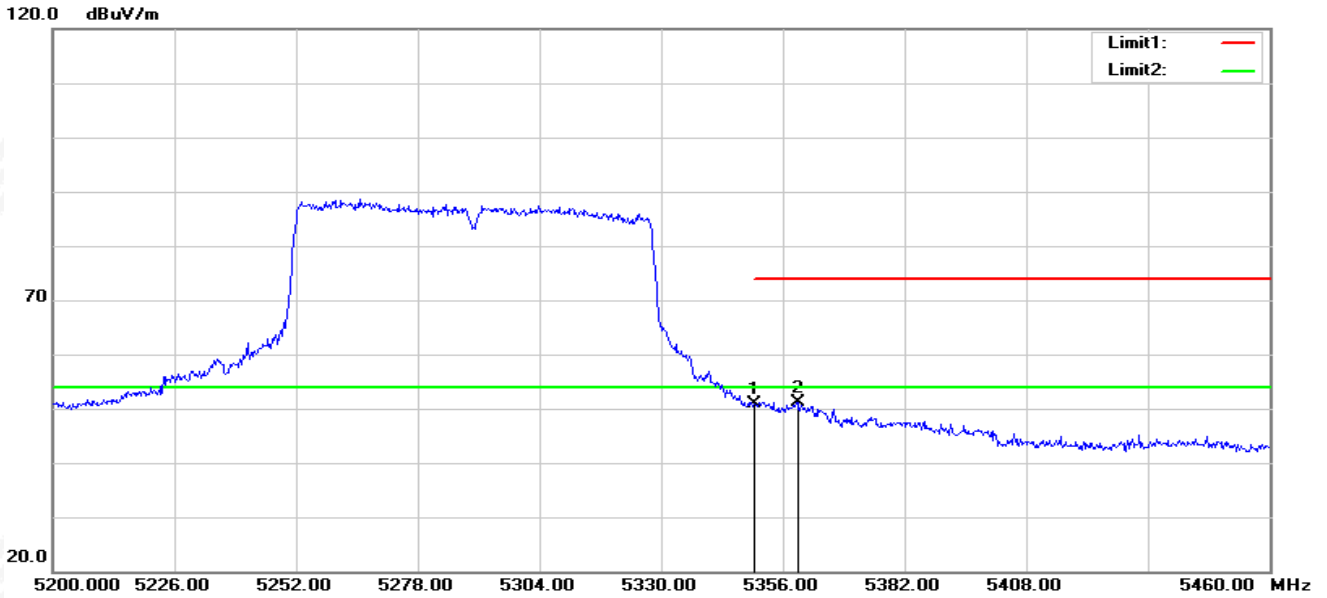

No.	Frequency (MHz)	Reading (dBuV)	Correct Factor(dB/m)	Result (dBuV/m)	Limit (dBuV/m)	Margin (dB)	Remark
1	5350.000	56.11	-5.23	50.88	74.00	-23.12	peak
2	5359.120	56.42	-5.23	51.19	74.00	-22.81	peak

802.11ac80-H-V

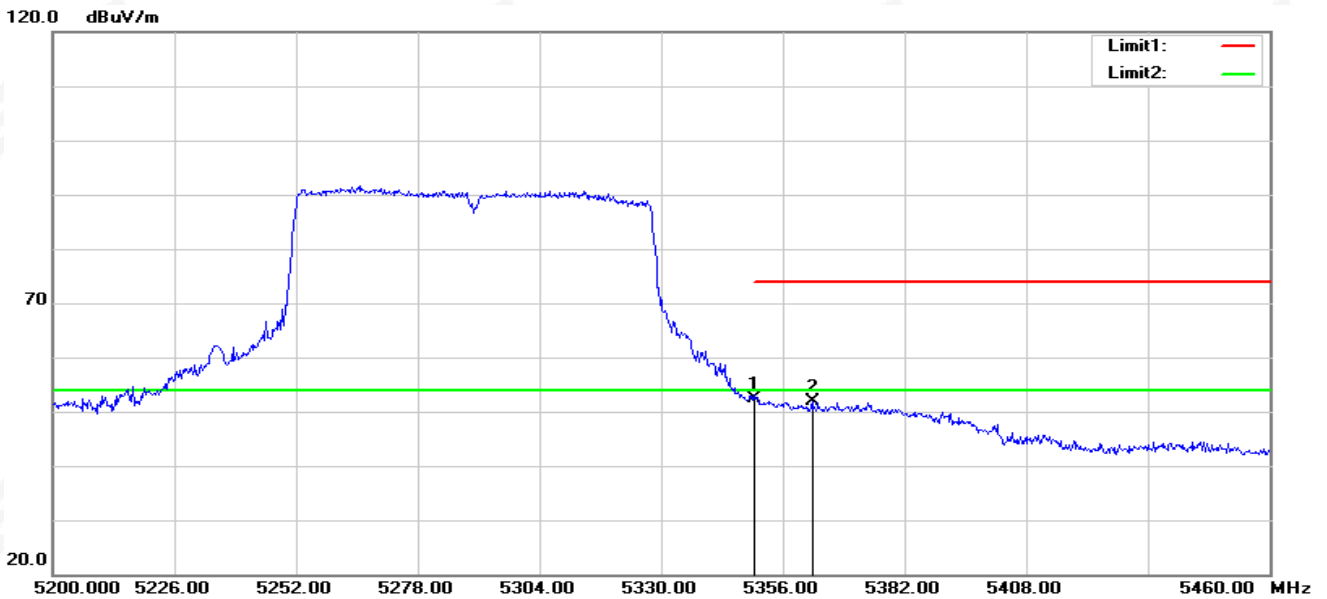

No.	Frequency (MHz)	Reading (dBuV)	Correct Factor(dB/m)	Result (dBuV/m)	Limit (dBuV/m)	Margin (dB)	Remark
1	5350.000	57.57	-5.23	52.34	74.00	-21.66	peak
2	5362.240	57.19	-5.23	51.96	74.00	-22.04	peak

Note: All modes have been tested. Only the worst mode shown in the report.



U-NII-2C 5470-5725MHz

802.11ac20-L-H

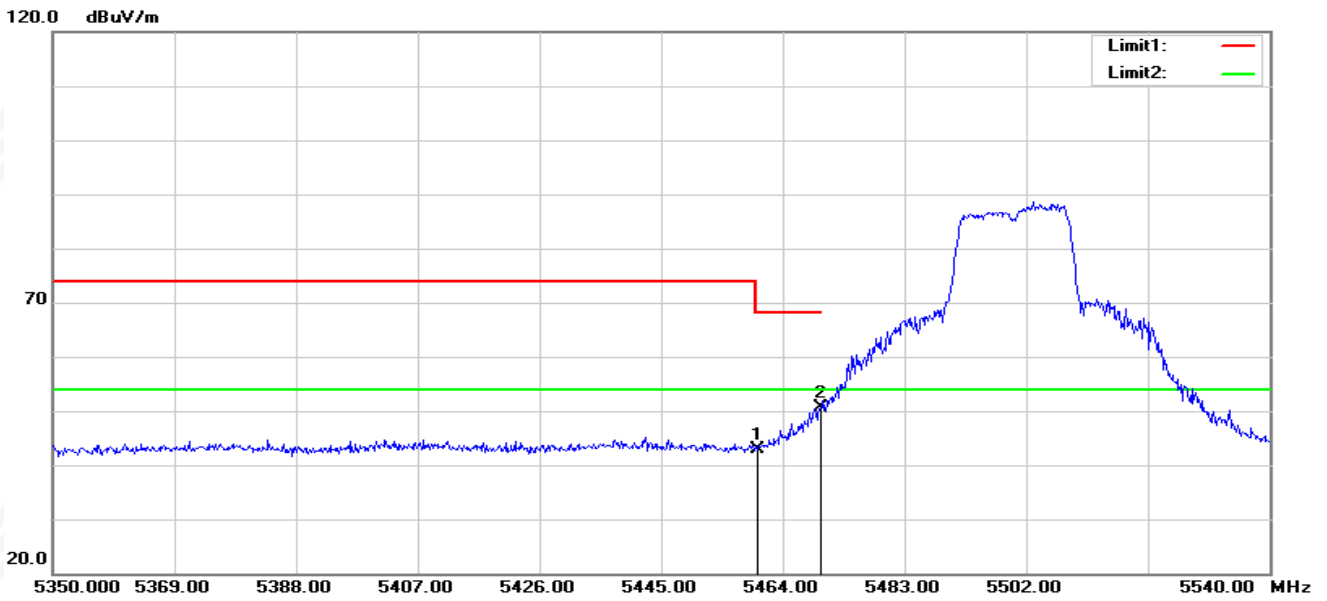

No.	Frequency (MHz)	Reading (dBuV)	Correct Factor(dB/m)	Result (dBuV/m)	Limit (dBuV/m)	Margin (dB)	Remark
1	5460.000	47.92	-5.11	42.81	68.20	-25.39	peak
2	5470.000	55.69	-5.09	50.60	68.20	-17.60	peak

802.11ac20-L-V

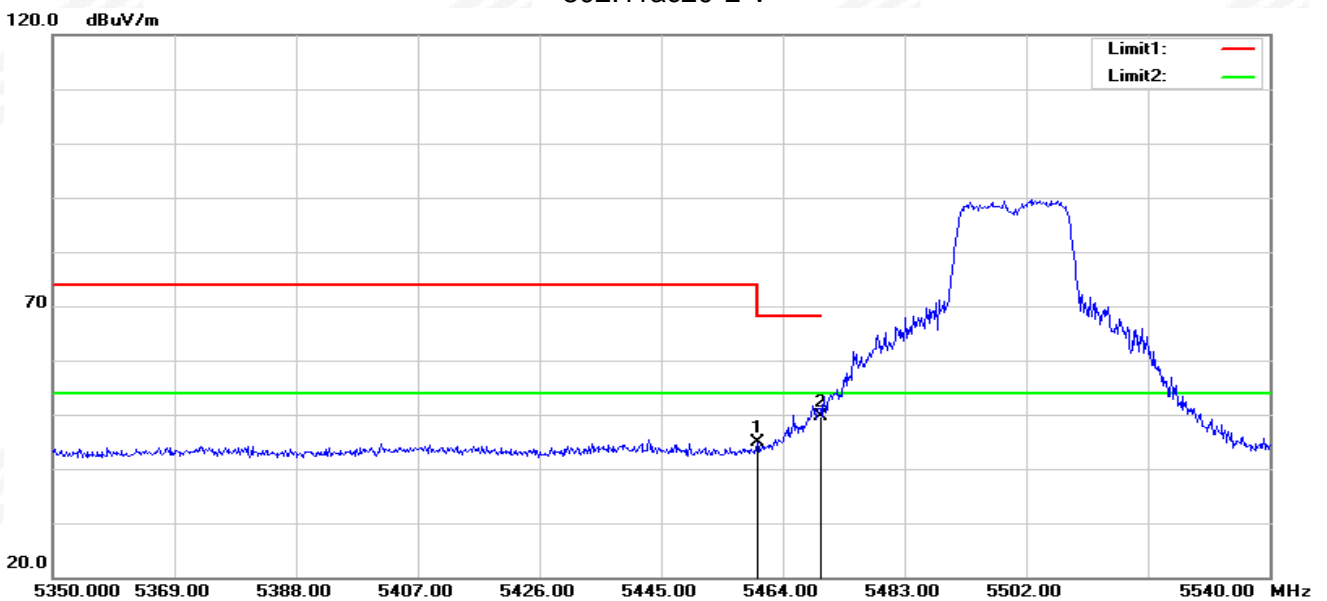

No.	Frequency (MHz)	Reading (dBuV)	Correct Factor(dB/m)	Result (dBuV/m)	Limit (dBuV/m)	Margin (dB)	Remark
1	5460.000	49.88	-5.11	44.77	68.20	-23.43	peak
2	5470.000	54.69	-5.09	49.60	68.20	-18.60	peak



802.11ac20-H-H

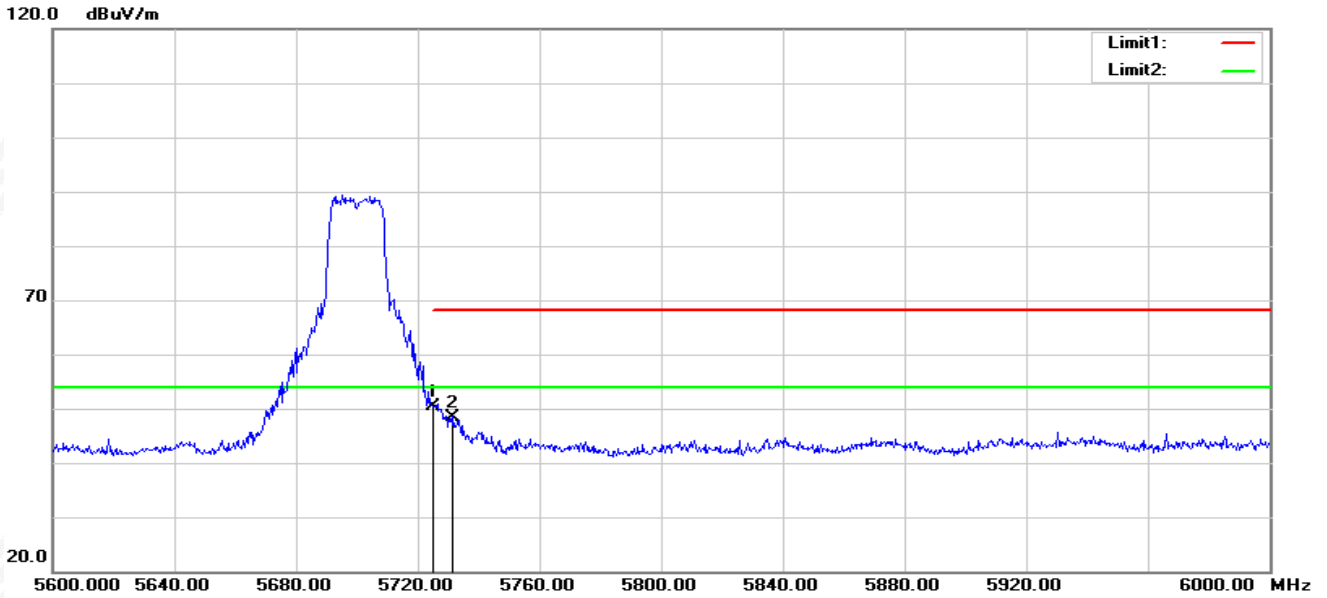

No.	Frequency (MHz)	Reading (dBuV)	Correct Factor(dB/m)	Result (dBuV/m)	Limit (dBuV/m)	Margin (dB)	Remark
1	5725.000	55.02	-4.57	50.45	68.20	-17.75	peak
2	5731.600	53.05	-4.55	48.50	68.20	-19.70	peak

802.11ac20-H-V

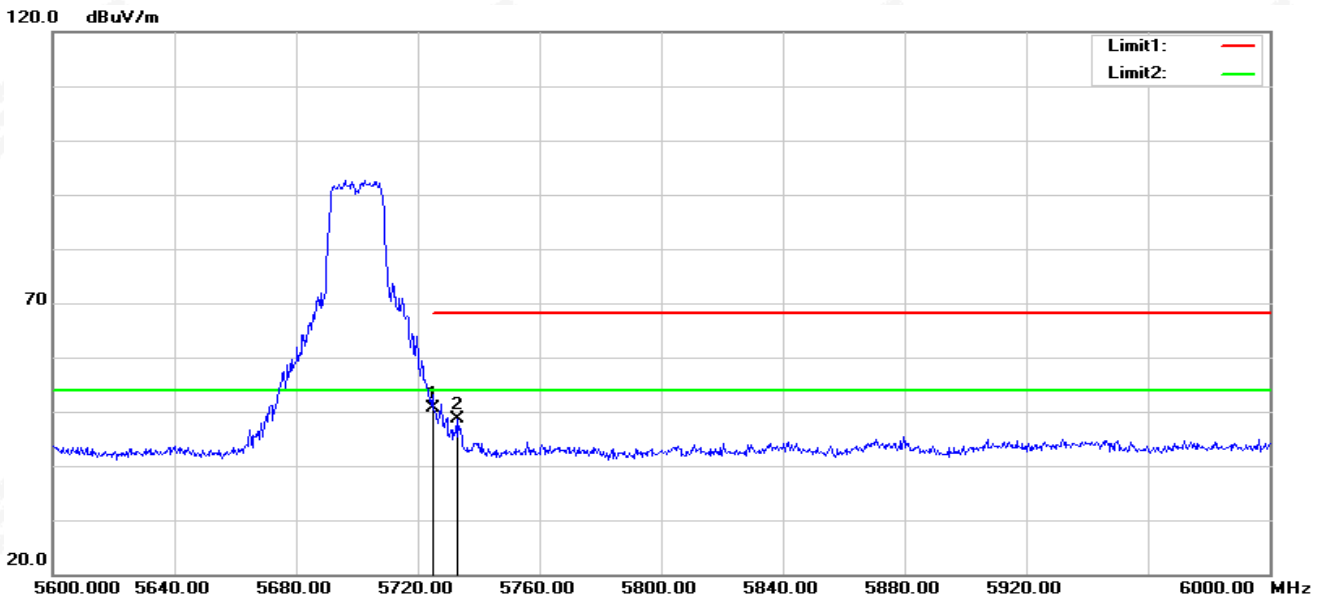

No.	Frequency (MHz)	Reading (dBuV)	Correct Factor(dB/m)	Result (dBuV/m)	Limit (dBuV/m)	Margin (dB)	Remark
1	5725.000	55.13	-4.57	50.56	68.20	-17.64	peak
2	5732.800	53.28	-4.55	48.73	68.20	-19.47	peak



802.11ac40-L-H

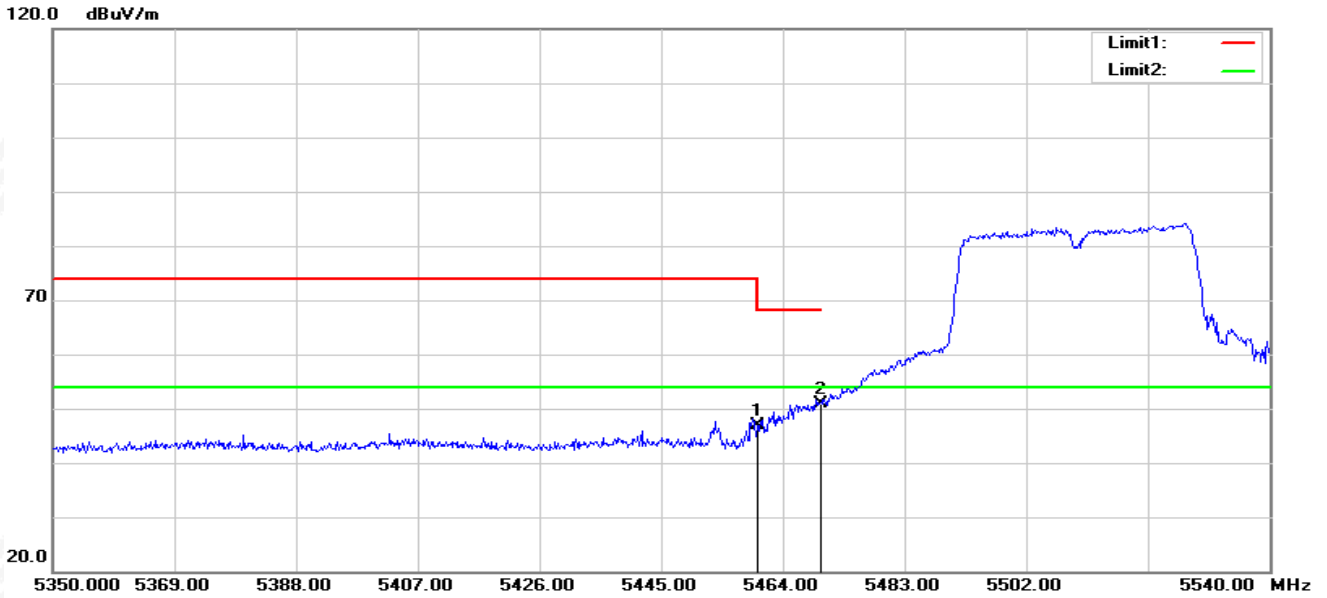

No.	Frequency (MHz)	Reading (dBuV)	Correct Factor(dB/m)	Result (dBuV/m)	Limit (dBuV/m)	Margin (dB)	Remark
1	5460.000	52.07	-5.11	46.96	68.20	-21.24	peak
2	5470.000	55.91	-5.09	50.82	68.20	-17.38	peak

802.11ac40-L-V

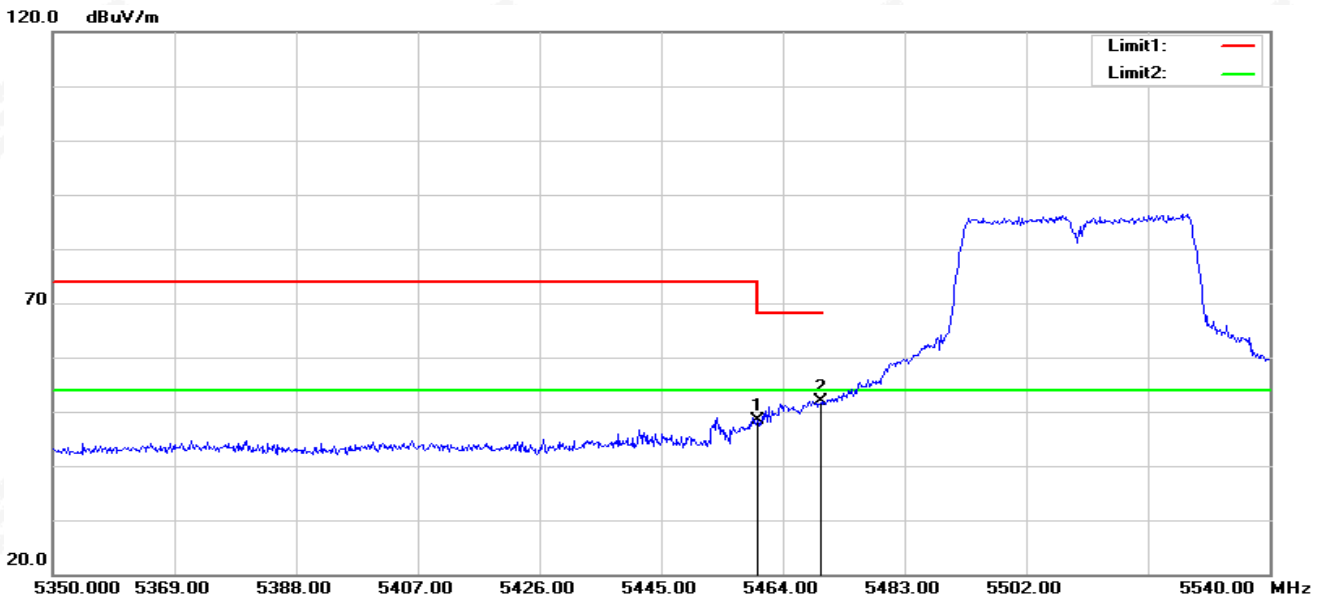

No.	Frequency (MHz)	Reading (dBuV)	Correct Factor(dB/m)	Result (dBuV/m)	Limit (dBuV/m)	Margin (dB)	Remark
1	5460.000	53.40	-5.11	48.29	68.20	-19.91	peak
2	5470.000	57.04	-5.09	51.95	68.20	-16.25	peak



802.11ac40-H-H

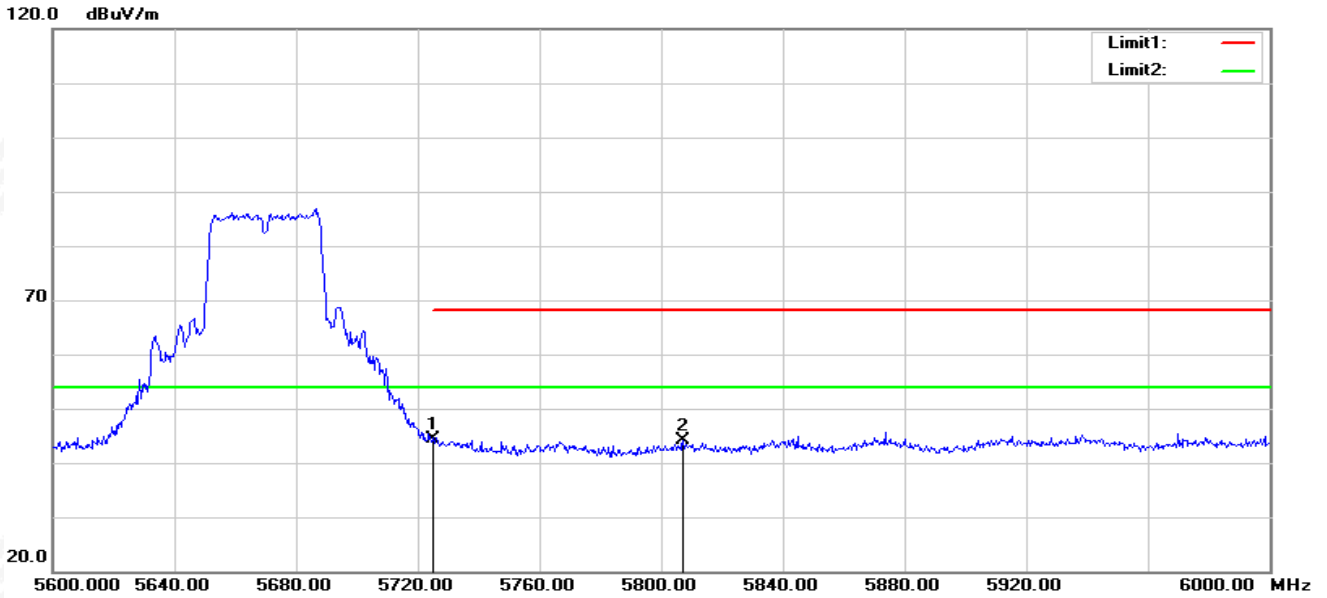

No.	Frequency (MHz)	Reading (dBuV)	Correct Factor(dB/m)	Result (dBuV/m)	Limit (dBuV/m)	Margin (dB)	Remark
1	5725.000	48.90	-4.57	44.33	68.20	-23.87	peak
2	5807.200	48.33	-4.29	44.04	68.20	-24.16	peak

802.11ac40-H-V

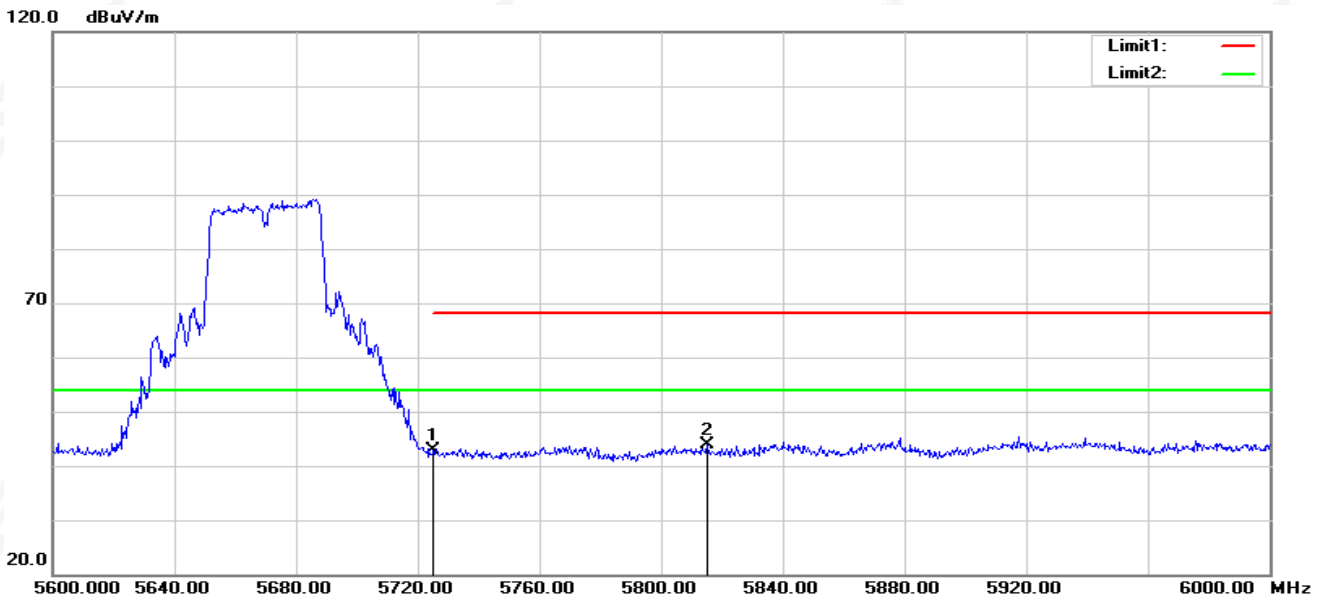

No.	Frequency (MHz)	Reading (dBuV)	Correct Factor(dB/m)	Result (dBuV/m)	Limit (dBuV/m)	Margin (dB)	Remark
1	5725.000	47.56	-4.57	42.99	68.20	-25.21	peak
2	5815.200	48.20	-4.26	43.94	68.20	-24.26	peak



802.11ac80-L-H

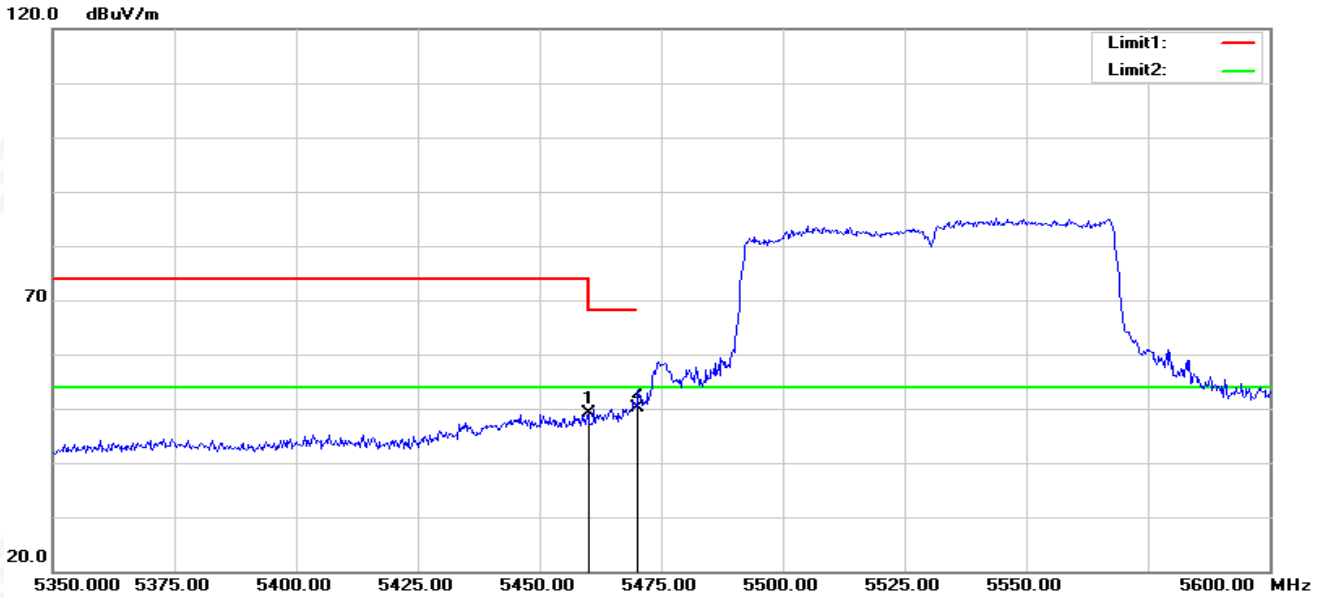

No.	Frequency (MHz)	Reading (dBuV)	Correct Factor(dB/m)	Result (dBuV/m)	Limit (dBuV/m)	Margin (dB)	Remark
1	5460.000	54.36	-5.11	49.25	68.20	-18.95	peak
2	5470.000	55.28	-5.09	50.19	68.20	-18.01	peak

802.11ac80-L-V

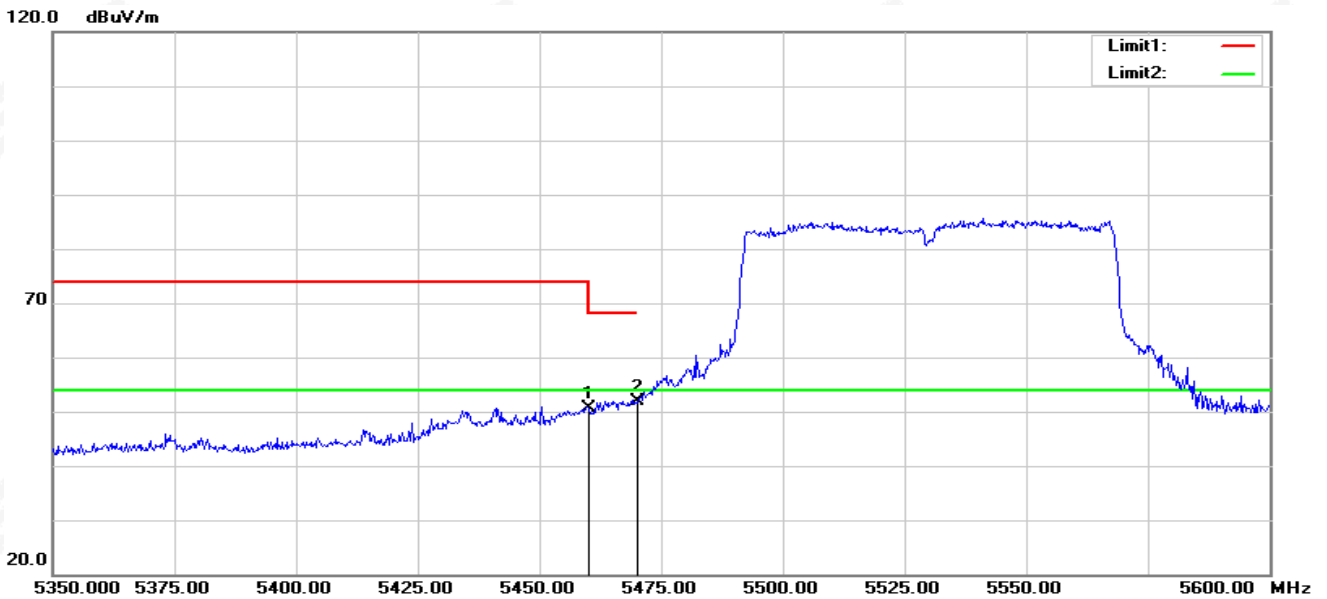

No.	Frequency (MHz)	Reading (dBuV)	Correct Factor(dB/m)	Result (dBuV/m)	Limit (dBuV/m)	Margin (dB)	Remark
1	5460.000	55.65	-5.11	50.54	68.20	-17.66	peak
2	5470.000	56.97	-5.09	51.88	68.20	-16.32	peak



802.11ac80-H-H

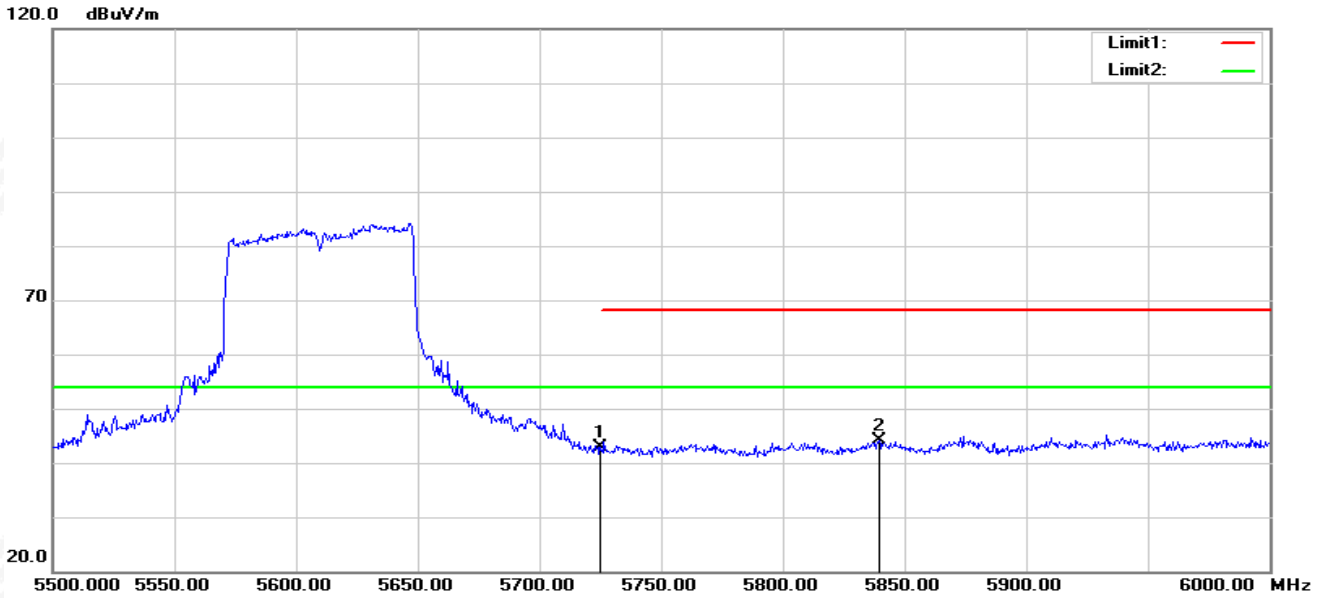

No.	Frequency (MHz)	Reading (dBuV)	Correct Factor(dB/m)	Result (dBuV/m)	Limit (dBuV/m)	Margin (dB)	Remark
1	5725.000	47.34	-4.57	42.77	68.20	-25.43	peak
2	5839.500	48.16	-4.15	44.01	68.20	-24.19	peak

802.11ac80-H-V

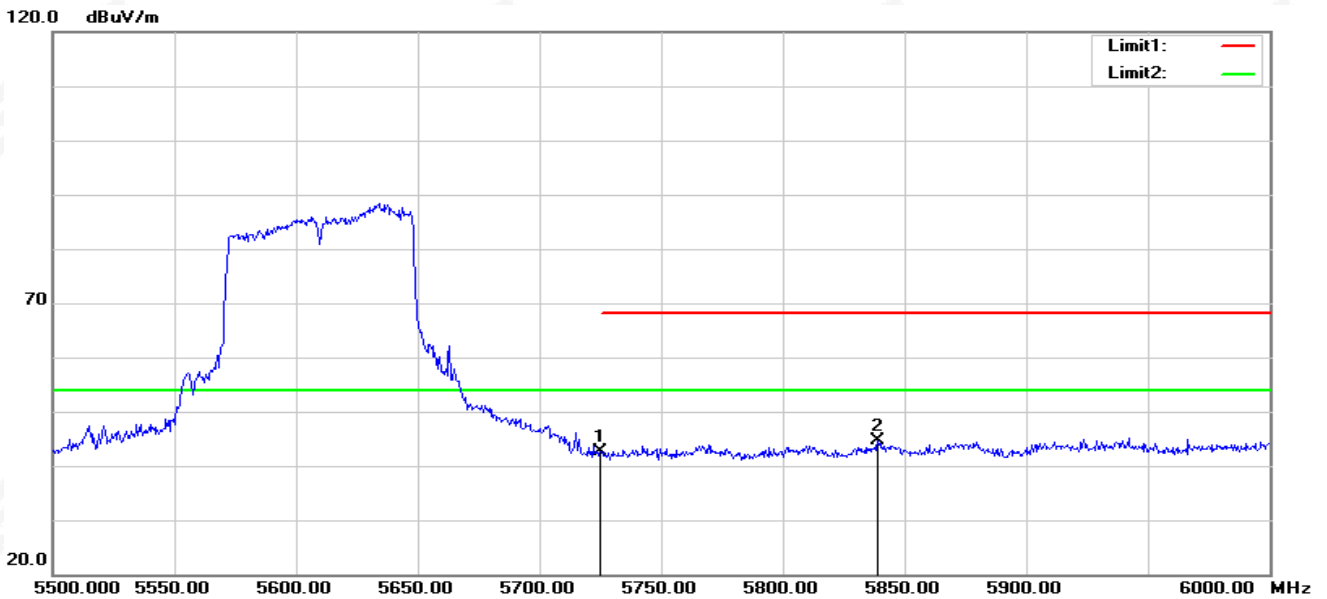

No.	Frequency (MHz)	Reading (dBuV)	Correct Factor(dB/m)	Result (dBuV/m)	Limit (dBuV/m)	Margin (dB)	Remark
1	5725.000	47.22	-4.57	42.65	68.20	-25.55	peak
2	5839.000	48.88	-4.15	44.73	68.20	-23.47	peak

Note: All modes have been tested. Only the worst mode shown in the report.

U-NII-3 (5.725-5.85 GHz)

802.11n20-L-H

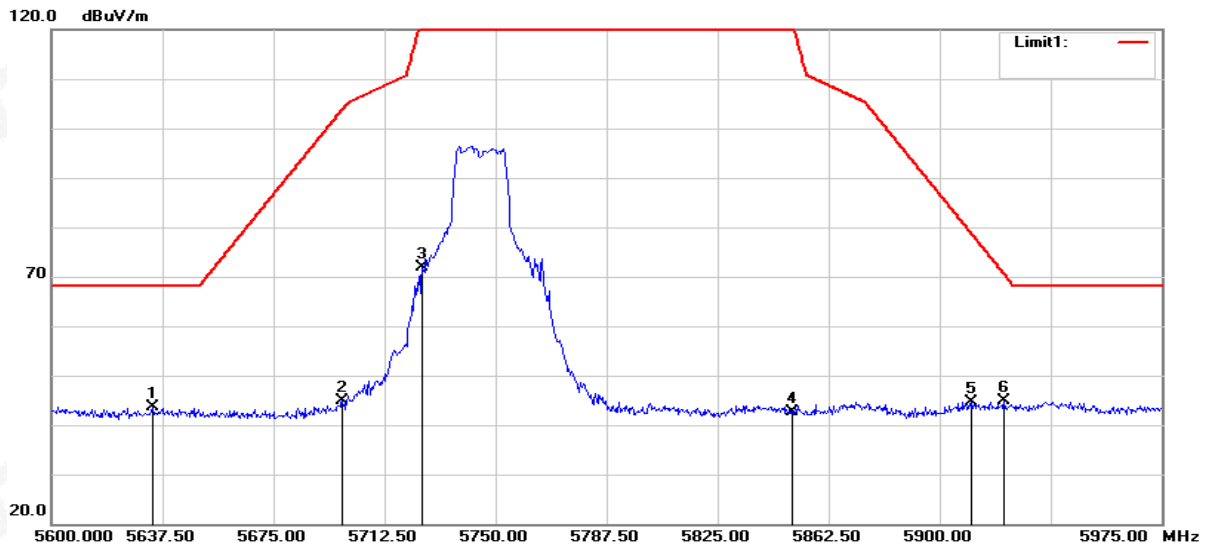

No.	Frequency (MHz)	Reading (dBuV)	Correct Factor(dB/m)	Result (dBuV/m)	Limit (dBuV/m)	Margin (dB)	Remark
1	5634.125	48.37	-4.69	43.68	68.20	-24.52	peak
2	5698.250	49.51	-4.66	44.85	103.91	-59.06	peak
3	5725.000	76.33	-4.57	71.76	122.20	-50.44	peak
4	5850.000	46.73	-4.10	42.63	122.20	-79.57	peak
5	5910.875	48.64	-3.90	44.74	78.65	-33.91	peak
6	5921.750	48.78	-3.92	44.86	70.61	-25.75	peak

802.11n20-L-V

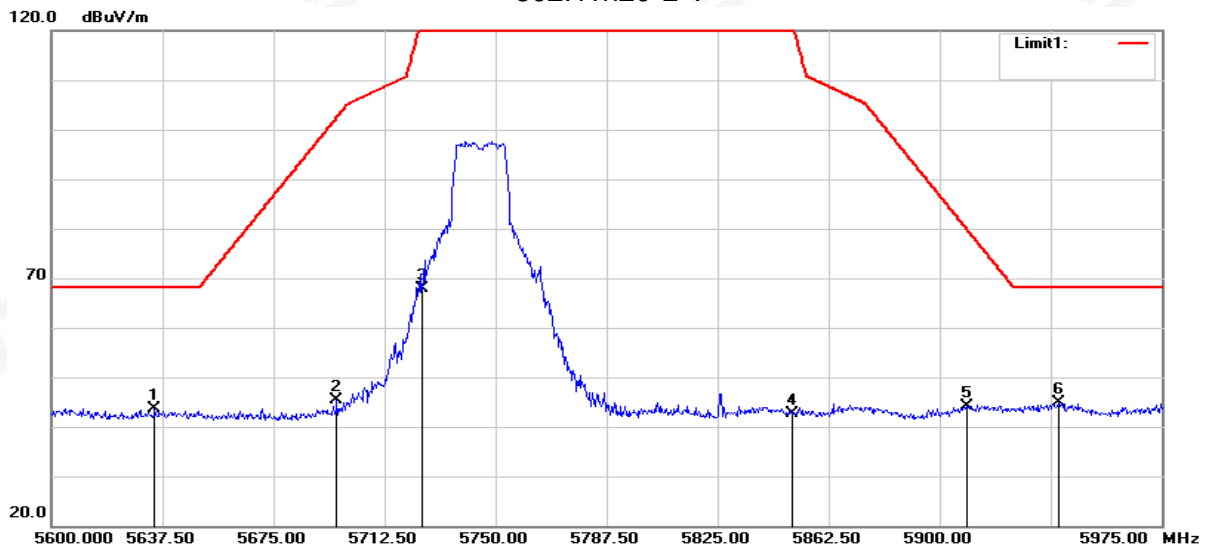

No.	Frequency (MHz)	Reading (dBuV)	Correct Factor(dB/m)	Result (dBuV/m)	Limit (dBuV/m)	Margin (dB)	Remark
1	5634.875	48.41	-4.68	43.73	68.20	-24.47	peak
2	5696.375	50.11	-4.67	45.44	102.52	-57.08	peak
3	5725.000	72.36	-4.57	67.79	122.20	-54.41	peak
4	5850.000	46.79	-4.10	42.69	122.20	-79.51	peak
5	5909.000	47.94	-3.90	44.04	80.04	-36.00	peak
6	5940.125	48.86	-3.95	44.91	68.20	-23.29	peak

802.11n20-H-H

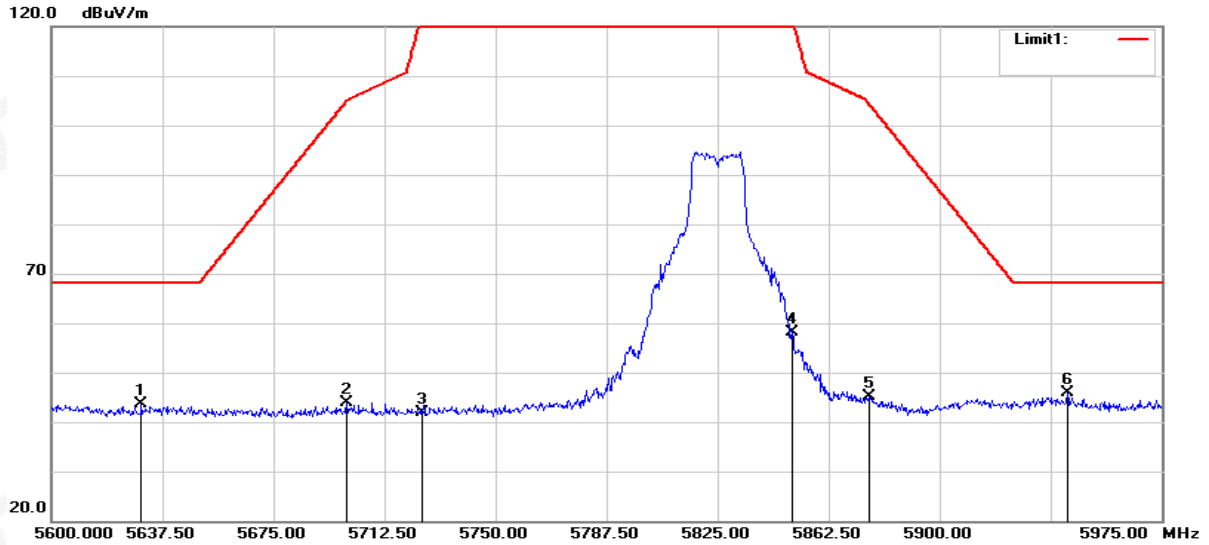

No.	Frequency (MHz)	Reading (dBuV)	Correct Factor(dB/m)	Result (dBuV/m)	Limit (dBuV/m)	Margin (dB)	Remark
1	5630.375	48.37	-4.69	43.68	68.20	-24.52	peak
2	5699.750	48.44	-4.66	43.78	105.02	-61.24	peak
3	5725.000	46.47	-4.57	41.90	122.20	-80.30	peak
4	5850.000	62.35	-4.10	58.25	122.20	-63.95	peak
5	5876.000	49.12	-3.99	45.13	104.46	-59.33	peak
6	5943.125	49.83	-3.95	45.88	68.20	-22.32	peak

802.11n20-H-V

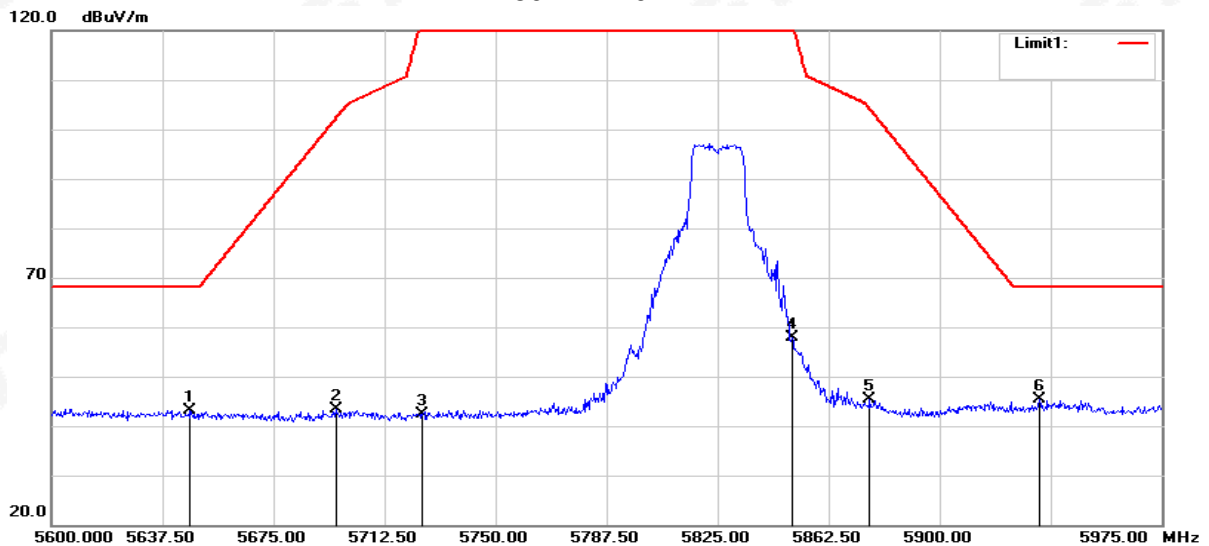

No.	Frequency (MHz)	Reading (dBuV)	Correct Factor(dB/m)	Result (dBuV/m)	Limit (dBuV/m)	Margin (dB)	Remark
1	5646.875	47.90	-4.69	43.21	68.20	-24.99	peak
2	5696.000	48.10	-4.67	43.43	102.24	-58.81	peak
3	5725.000	46.86	-4.57	42.29	122.20	-79.91	peak
4	5850.000	62.04	-4.10	57.94	122.20	-64.26	peak
5	5876.375	49.41	-3.99	45.42	104.18	-58.76	peak
6	5933.750	49.31	-3.94	45.37	68.20	-22.83	peak

802.11ac40-L-H

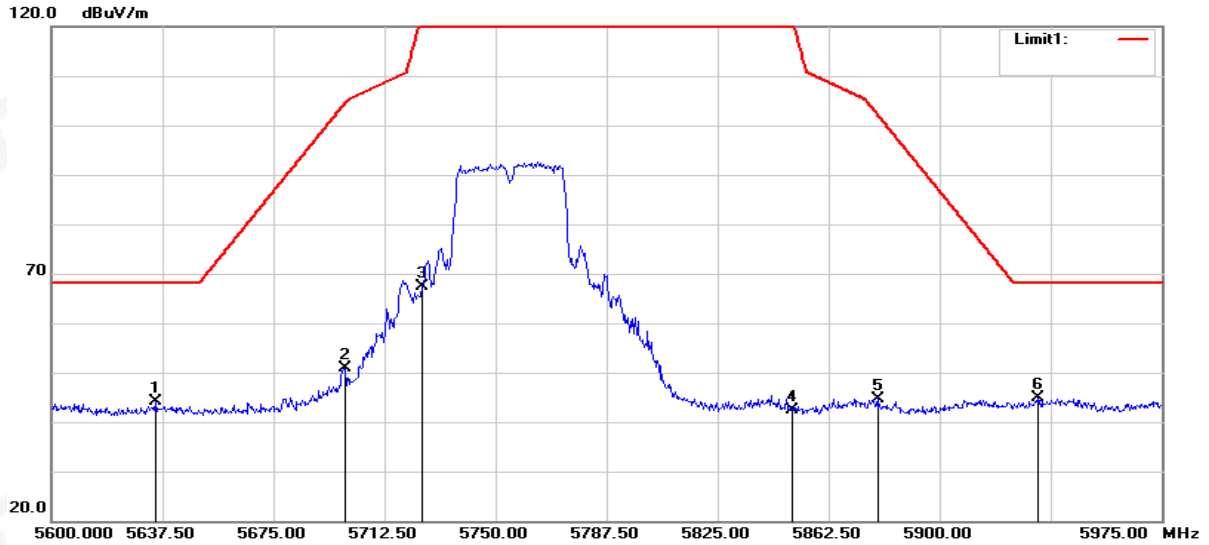

No.	Frequency (MHz)	Reading (dBuV)	Correct Factor(dB/m)	Result (dBuV/m)	Limit (dBuV/m)	Margin (dB)	Remark
1	5635.250	48.70	-4.68	44.02	68.20	-24.18	peak
2	5699.375	55.52	-4.66	50.86	104.74	-53.88	peak
3	5725.000	72.04	-4.57	67.47	122.20	-54.73	peak
4	5850.000	46.45	-4.10	42.35	122.20	-79.85	peak
5	5879.000	48.72	-3.97	44.75	102.24	-57.49	peak
6	5933.375	48.79	-3.94	44.85	68.20	-23.35	peak

802.11ac40-L-V

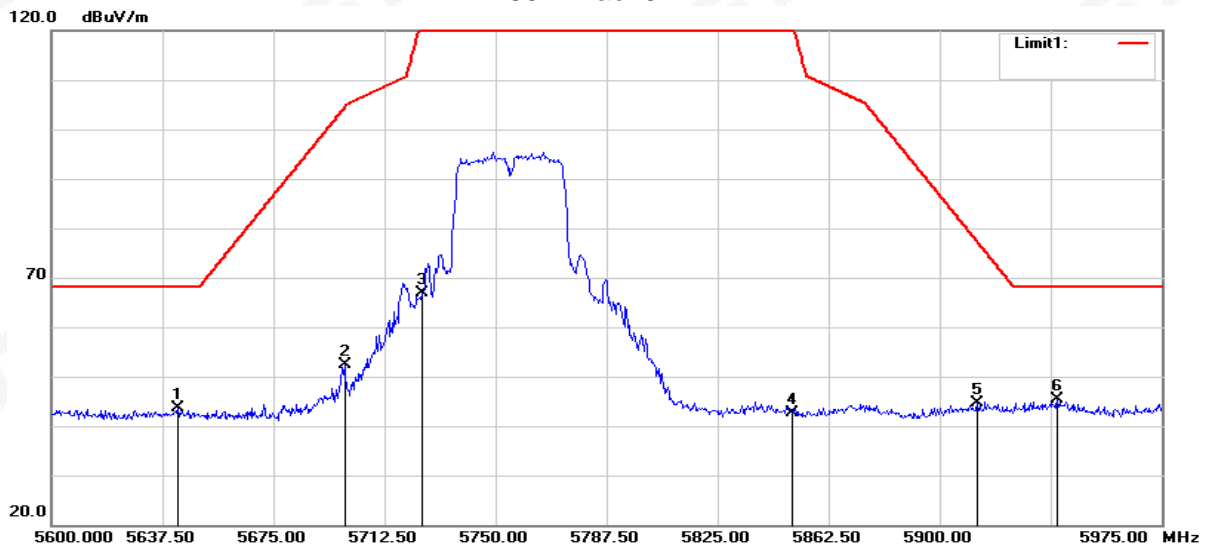

No.	Frequency (MHz)	Reading (dBuV)	Correct Factor(dB/m)	Result (dBuV/m)	Limit (dBuV/m)	Margin (dB)	Remark
1	5642.750	48.32	-4.68	43.64	68.20	-24.56	peak
2	5699.000	57.06	-4.66	52.40	104.46	-52.06	peak
3	5725.000	71.35	-4.57	66.78	122.20	-55.42	peak
4	5850.000	46.78	-4.10	42.68	122.20	-79.52	peak
5	5912.750	48.49	-3.90	44.59	77.27	-32.68	peak
6	5939.750	49.39	-3.95	45.44	68.20	-22.76	peak

802.11ac40-H-H

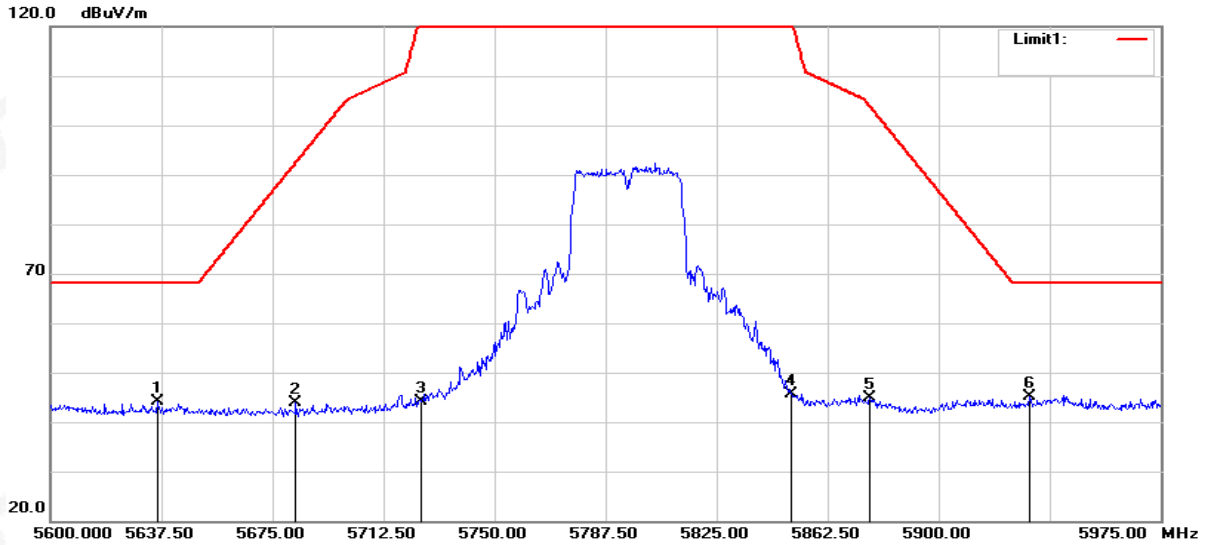

No.	Frequency (MHz)	Reading (dBuV)	Correct Factor(dB/m)	Result (dBuV/m)	Limit (dBuV/m)	Margin (dB)	Remark
1	5636.000	48.71	-4.68	44.03	68.20	-24.17	peak
2	5682.875	48.59	-4.67	43.92	92.53	-48.61	peak
3	5725.000	48.68	-4.57	44.11	122.20	-78.09	peak
4	5850.000	49.75	-4.10	45.65	122.20	-76.55	peak
5	5876.750	48.90	-3.99	44.91	103.91	-59.00	peak
6	5930.750	49.03	-3.93	45.10	68.20	-23.10	peak

802.11ac40-H-V

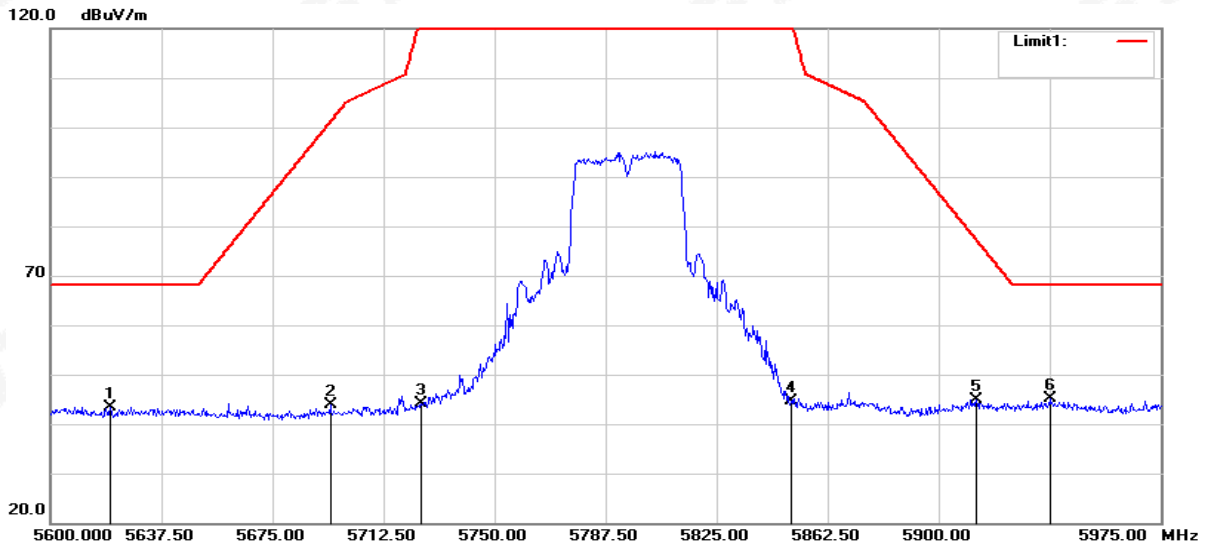

No.	Frequency (MHz)	Reading (dBuV)	Correct Factor(dB/m)	Result (dBuV/m)	Limit (dBuV/m)	Margin (dB)	Remark
1	5620.250	48.10	-4.69	43.41	68.20	-24.79	peak
2	5694.500	48.45	-4.66	43.79	101.13	-57.34	peak
3	5725.000	48.61	-4.57	44.04	122.20	-78.16	peak
4	5850.000	48.70	-4.10	44.60	122.20	-77.60	peak
5	5912.750	48.74	-3.90	44.84	77.27	-32.43	peak
6	5937.500	49.00	-3.94	45.06	68.20	-23.14	peak

802.11ac80-H

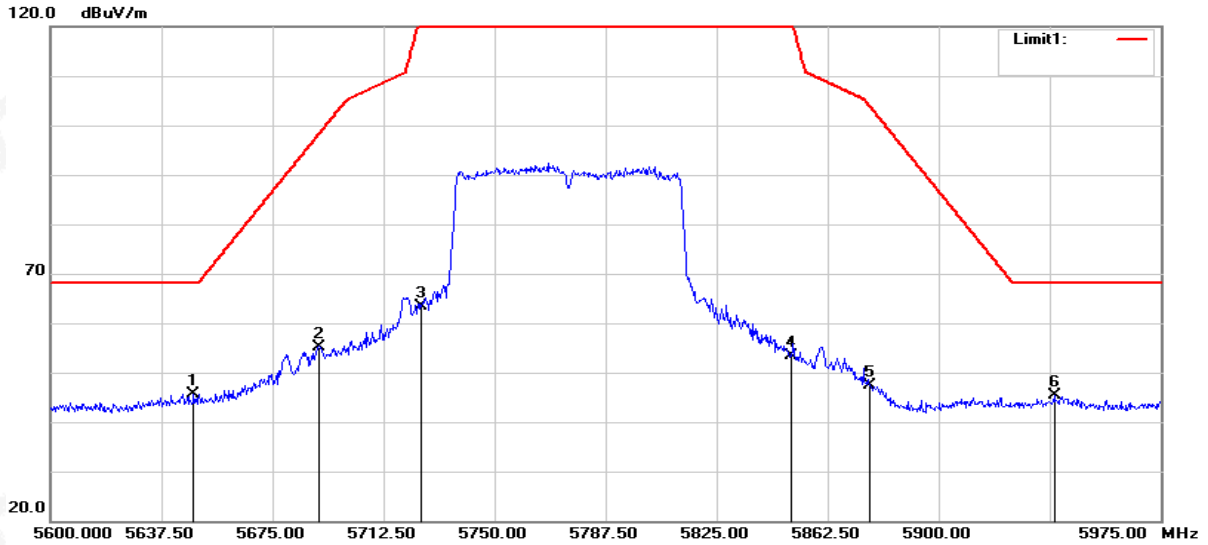

No.	Frequency (MHz)	Reading (dBuV)	Correct Factor(dB/m)	Result (dBuV/m)	Limit (dBuV/m)	Margin (dB)	Remark
1	5648.375	50.39	-4.68	45.71	68.20	-22.49	peak
2	5690.750	59.91	-4.66	55.25	98.36	-43.11	peak
3	5725.000	68.04	-4.57	63.47	122.20	-58.73	peak
4	5850.000	57.40	-4.10	53.30	122.20	-68.90	peak
5	5876.750	51.31	-3.99	47.32	103.91	-56.59	peak
6	5939.000	49.22	-3.95	45.27	68.20	-22.93	peak

802.11ac80-V

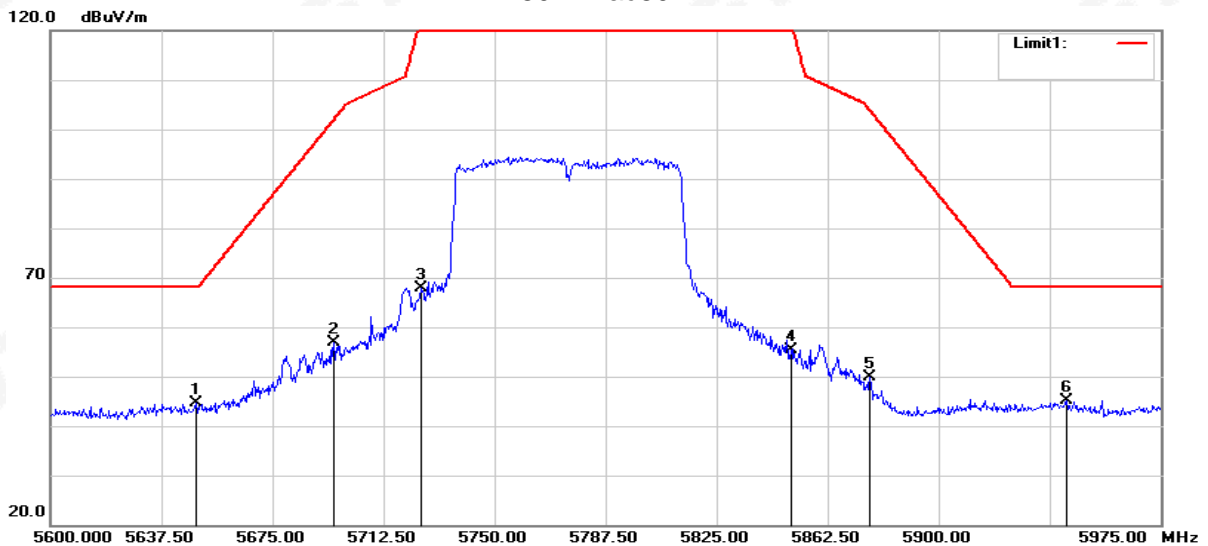

No.	Frequency (MHz)	Reading (dBuV)	Correct Factor(dB/m)	Result (dBuV/m)	Limit (dBuV/m)	Margin (dB)	Remark
1	5649.125	49.30	-4.68	44.62	68.20	-23.58	peak
2	5695.625	61.44	-4.66	56.78	101.96	-45.18	peak
3	5725.000	72.48	-4.57	67.91	122.20	-54.29	peak
4	5850.000	59.54	-4.10	55.44	122.20	-66.76	peak
5	5876.750	53.88	-3.99	49.89	103.91	-54.02	peak
6	5943.125	49.10	-3.95	45.15	68.20	-23.05	peak

Note: All modes have been tested. Only the worst mode shown in the report.

4. POWER SPECTRAL DENSITY TEST

4.1 LIMIT

1. For mobile and portable client devices in the 5.15-5.25 GHz band, , the maximum power spectral density shall not exceed 11 dBm in any 1 megahertz band. If transmitting antennas of directional gain greater than 6 dBi are used, both the maximum conducted output power and the maximum power spectral density shall be reduced by the amount in dB that the directional gain of the antenna exceeds 6 dBi.
2. For the 5.25-5.35 GHz and 5.47-5.725 GHz bands, the maximum power spectral density shall not exceed 11 dBm in any 1 megahertz band. If transmitting antennas of directional gain greater than 6 dBi are used, both the maximum conducted output power and the maximum power spectral density shall be reduced by the amount in dB that the directional gain of the antenna exceeds 6 dBi.
3. For the band 5.725-5.850 GHz, the peak power spectral density shall not exceed 30 dBm in any 500KHz band. If transmitting antenna directional gain is greater than 6 dBi, both the maximum conducted output power and the peak power spectral density shall be reduced by the amount in dB that the directional gain of the antenna exceeds 6 dBi.

4.2 TEST PROCEDURE

1. The setting follows Method SA-1 of FCC KDB 789033 D02 General U-NII Test Procedures New Rules v02r01.

For devices operating in the band, the rules specify a measurement bandwidth of 500 kHz. Many spectrum analyzers do not have 500 kHz RBW, thus a narrower RBW may need to be used. The rules permit the use of a RBWs less than 1 MHz, or 500 kHz, "provided that the measured power is integrated over the full reference bandwidth" to show the total power over the specified measurement bandwidth (*i.e.*, 1 MHz, or 500 kHz). If measurements are performed using a reduced resolution bandwidth (< 1 MHz, or < 500 kHz) and integrated over 1 MHz, or 500 KHz bandwidth, the following adjustments to the procedures apply:

- a) Set $RBW \geq 1/T$, where T is defined in section II.B.I.a).
- b) Set $VBW \geq 3 RBW$.
- c) If measurement bandwidth of Maximum PSD is specified in 500 kHz, add $10 \log (500\text{kHz}/RBW)$ to the measured result, whereas $RBW (< 500 \text{ kHz})$ is the reduced resolution bandwidth of the spectrum analyzer set during measurement.
- d) If measurement bandwidth of Maximum PSD is specified in 1 MHz, add $10 \log (1\text{MHz}/RBW)$ to the measured result, whereas $RBW (< 1 \text{ MHz})$ is the reduced resolution bandwidth of spectrum analyzer set during measurement.
- e) Care must be taken to ensure that the measurements are performed during a period of continuous transmission or are corrected upward for duty cycle.

Note: As a practical matter, it is recommended to use reduced RBW of 100 kHz for the sections 5.c) and 5.d) above, since $RBW=100 \text{ KHZ}$ is available on nearly all spectrum analyzers.

4.3 DEVIATION FROM STANDARD

No deviation.

4.4 TEST SETUP



4.5 EUT OPERATION CONDITIONS

The EUT tested system was configured as the statements of 2.1 Unless otherwise a special operating condition is specified in the follows during the testing.

4.6 TEST RESULTS

Note: The test data please reference to attachment “STS2405013W04_Appendix 5G WIFI”.

5. BANDWIDTH MEASUREMENT

5.1 EMISSION BANDWIDTH (EBW) 26 BANDWID PROCEDURES / LIMIT

The following procedure shall be used for measuring 26 bandwidth.

5.1.1 TEST PROCEDURE

1. The testing follows FCC KDB 789033 D02 General UNII Test Procedures New Rules v02r01.
2. Set RBW = approximately 1% of the emission bandwidth.
3. Set the VBW \geq RBW.
4. Detector = Peak.
5. Trace mode = max hold.
6. Measure the maximum width of the emission that is 26 dB down from the peak of the emission. Compare this with the RBW setting of the analyzer. Readjust RBW and repeat measurement as needed until the RBW/EBW ratio is approximately 1%.

5.1.2 DEVIATION FROM STANDARD

No deviation.

5.1.3 TEST SETUP



5.1.4 EUT OPERATION CONDITIONS

The EUT tested system was configured as the statements of 2.4 Unless otherwise a special operating condition is specified in the follows during the testing.

5.1.5 TEST RESULTS

The test data please reference to attachment "STS2405013W04_Appendix 5G WIFI".

5.2 OCCUPIED BANDWIDTH (99%) TEST APPLIED PROCEDURES / LIMIT

The following procedure shall be used for measuring (99 %) power bandwidth.

5.2.1 TEST PROCEDURE

1. The testing follows FCC KDB 789033 D02 General UNII Test Procedures v02r01. The following procedure shall be used for measuring (99 %) power bandwidth:
 1. Set center frequency to the nominal EUT channel center frequency.
 2. Set span = 1.5 times to 5.0 times the OBW.
 3. Set RBW = 1 % to 5 % of the OBW
 4. Set VBW $\geq 3 \cdot$ RBW
 5. Video averaging is not permitted. Where practical, a sample detection and single sweep mode shall be used. Otherwise, peak detection and max hold mode (until the trace stabilizes) shall be used.
 6. Use the 99 % power bandwidth function of the instrument (if available).
 7. If the instrument does not have a 99 % power bandwidth function, the trace data points are recovered and directly summed in power units. The recovered amplitude data points, beginning at the lowest frequency, are placed in a running sum until 0.5 % of the total is reached; that frequency is recorded as the lower frequency. The process is repeated until 99.5 % of the total is reached; that frequency is recorded as the upper frequency. The 99% occupied bandwidth is the difference between these two frequencies.

5.2.2 DEVIATION FROM STANDARD

No deviation.

5.2.3 TEST SETUP



5.2.4 EUT OPERATION CONDITIONS

The EUT tested system was configured as the statements of 2.4 Unless otherwise a special operating condition is specified in the follows during the testing.

5.2.5 TEST RESULTS

The test data please reference to attachment "STS2405013W04_Appendix 5G WIFI".

5.3 MINIMUM EMISSION BANDWIDTH(6 DB) PROCEDURES / LIMIT

Section 15.407(e) specifies the minimum 6 dB emission bandwidth of at least 500 KHz for the band 5.725-5.85 GHz. The following procedure shall be used for measuring this bandwidth.

5.3.1 TEST PROCEDURE

1. The testing follows FCC KDB 789033 D02 General UNII Test Procedures v02r01.
 - a) Set RBW = 100 kHz.
 - b) Set the video bandwidth (VBW) $\geq 3 \times$ RBW.
 - c) Detector = Peak.
 - d) Trace mode = max hold.
 - e) Sweep = auto couple.
 - f) Allow the trace to stabilize.
 - g) Measure the maximum width of the emission that is constrained by the frequencies associated with the two outermost amplitude points (upper and lower frequencies) that are attenuated by 6 dB relative to the maximum level measured in the fundamental emission.

5.3.2 DEVIATION FROM STANDARD

No deviation.

5.3.3 TEST SETUP



5.3.4 EUT OPERATION CONDITIONS

The EUT tested system was configured as the statements of 2.4 Unless otherwise a special operating condition is specified in the follows during the testing.

5.3.5 TEST RESULTS

The test data please reference to attachment "STS2405013W04_Appendix 5G WIFI".

6. MAXIMUM CONDUCTED OUTPUT POWER

6.1 LIMIT

For mobile and portable client devices in the 5.15-5.25 GHz band, the maximum conducted output power over the frequency band of operation shall not exceed 250 mW provided the maximum antenna gain does not exceed 6 dBi. If transmitting antennas of directional gain greater than 6 dBi are used, both the maximum conducted output power and the maximum power spectral density shall be reduced by the amount in dB that the directional gain of the antenna exceeds 6 dBi.

For the 5.25-5.35 GHz and 5.47-5.725 GHz bands, the maximum conducted output power over the frequency bands of operation shall not exceed the lesser of 250 mW or $11 \text{ dBm} + 10 \log B$, where B is the 26 dB emission bandwidth in megahertz, If transmitting antennas of directional gain greater than 6 dBi are used.

For the band 5.725-5.85 GHz, the maximum conducted output power over the frequency band of operation shall not exceed 1 W. If transmitting antennas of directional gain greater than 6 dBi are used.

FCC Part15 (15.407) , Subpart E				
Section	Test Item	Limit	Frequency Range (MHz)	Result
15.407(a) (1) (iv)	Peak Output Power	0.25 watt	5150-5250	PASS
		The lesser of 250 mW or $11 \text{ dBm} + 10 \log (26 \text{ dB emission bandwidth})$	5250-5350 5470-5725	
15.407(a) (3)		1 watt	5725-5895	

6.2 TEST PROCEDURE

The EUT was directly connected to the Power Sensor&PC

6.3 DEVIATION FROM STANDARD

No deviation.

6.4 TEST SETUP

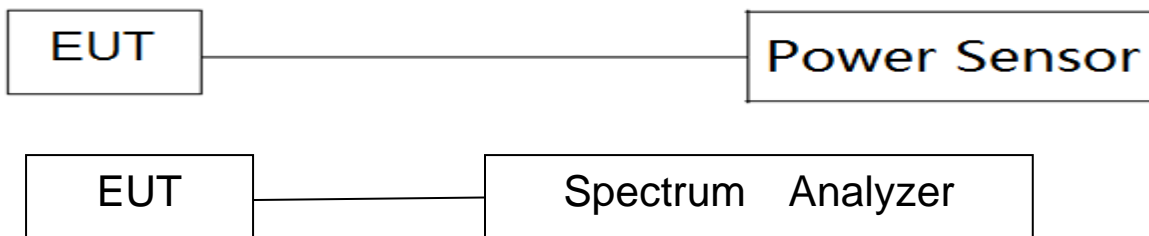

6.5 EUT OPERATION CONDITIONS

The EUT tested system was configured as the statements of 5 Unless otherwise a special operating condition is specified in the follows during the testing.

6.6 TEST RESULTS

Note: The test data please reference to attachment "STS2405013W04_Appendix 5G WIFI".

7. AUTOMATICALLY DISCONTINUE TRANSMISSION

7.1 LIMIT OF AUTOMATICALLY DISCONTINUE TRANSMISSION

The device shall automatically discontinue transmission in case of either absence of information to transmit or operational failure. These provisions are not intended to preclude the transmission of control or signaling information or the use of repetitive codes used by certain digital technologies to complete frame or burst intervals. Applicants shall include in their application for equipment authorization to describe how this requirement is met.

7.2 TEST RESULT OF AUTOMATICALLY DISCONTINUE TRANSMISSION

During no any information transmission, the EUT can automatically discontinue transmission and become standby mode for power saving. The EUT can detect the controlling signal of ACK message transmitting from remote device and verify whether it shall resend or discontinue transmission



8. ANTENNA REQUIREMENT

8.1 STANDARD REQUIREMENT

15.203 requirement: For intentional device, according to 15.203: an intentional radiator shall be designed to ensure that no antenna other than that furnished by the responsible party shall be used with the device.

8.2 EUT ANTENNA

The EUT antenna is PIFA Antenna. It comply with the standard requirement.



APPENDIX - PHOTOS OF TEST SETUP

Note: See test photos in setup photo document for the actual connections between Product and support equipment.

*****END OF THE REPORT*****