

Radio Test Report

Report No.: STS2405013W06

Issued for

WHOOOP INTERNATIONAL TRADING LIMITED

Flat-B 8/F Chong Gming Building 72 Cheung Sha Wan Road
Kowloon Hong Kong

Product Name: 4G SMARTPHONE

Brand Name: SUNTAK

Model Name: MOJO

Series Model(s): MOX 2

FCC ID: 2AP7LMOJO

Test Standards: 47 CFR Part 2, 22, 24, 27, 90

The test results presented in this report relate only to the object tested. This report shall not be reproduced, except in full, without the written approval of the Shenzhen STS Test Services Co., Ltd.



TEST REPORT

Applicant's Name: WHOOP INTERNATIONAL TRADING LIMITED
Address: Flat-B 8/F Chong Gming Building 72 Cheung Sha Wan Road
 Kowloon Hong Kong
Manufacturer's Name: Shenzhen Teleone Technology Co., Ltd
Address: Tower B 5/F, Shanshui Building, Nanshan Yungu Innovation
 Industry Park, 4093 Liuxian Avenue, Shenzhen, China

Product Description

Product Name: 4G SMARTPHONE
Brand Name: SUNTAK
Model Name: MOJO
Series Model(s): MOX 2

Test Standards.....: 47 CFR Part 2, 22, 24, 27, 90
Test Procedure: KDB 971168 D01 v03r01,ANSI C63.26(2015)

This device described above has been tested by STS, the test results show that the equipment under test (EUT) is in compliance with the FCC requirements. And it is applicable only to the tested sample identified in the report.
 The test results presented in this report relate only to the object tested. This report shall not be reproduced, except in full, without the written approval of the Shenzhen STS Test Services Co., Ltd.

Date of Test.....:
Date of receipt of test item.....: 08 May 2024
Date (s) of performance of tests.: 08 May 2024~ 17 May 2024
Date of Issue: 17 May 2024
Test Result: Pass

Testing Engineer : Lenon Hou
 (Lenon Hou)

Technical Manager : Chris Chen
 (Chris Chen)

Authorized Signatory : Bovey Yang
 (Bovey Yang)





Table of Contents	Page
1 INTRODUCTION	7
1.1 TEST FACTORY	7
1.2 MEASUREMENT UNCERTAINTY	7
2 PRODUCT INFORMATION	8
3 TEST CONFIGURATION OF EQUIPMENT UNDER TEST	12
4 MEASUREMENT INSTRUMENTS	15
5 TEST ITEMS	16
5.1 CONDUCTED OUTPUT POWER&TRANSMITTER RADIATED POWER	16
5.2 PEAK TO AVERAGE RATIO	70
5.3 OCCUPIED BANDWIDTH	71
5.4 FREQUENCY STABILITY	72
5.5 SPURIOUS EMISSIONS AT ANTENNA TERMINALS	83
5.6 BAND EDGE	84
5.7 FIELD STRENGTH OF SPURIOUS RADIATION MEASUREMENT	86
APPENDIX-PHOTOS OF TEST SETUP	198



Revision History

Rev.	Issue Date	Report No.	Effect Page	Contents
00	17 May 2024	STS2405013W06	ALL	Initial Issue



SUMMARY OF TEST RESULTS

Test procedures according to the technical standards:

The radiated emission testing was performed according to the procedures of KDB 971168 D01 v03r01 and ANSI C63.26(2015)

Test Description	FCC Rules	Band	Test Limit	Test Result
Conducted Output Power	2.1046	/	Reporting Only	PASS
Transmitter Radiated Power	22.913	B5, B26	ERP < 7 Watt	PASS
	24.232(c)	B2, B25	EIRP < 2Watt	
	27.50(b)	B13	ERP < 3 Watt	
	27.50(c)	B12, B71	ERP < 3 Watt	
	27.50(d)	B4, B66	EIRP < 1Watt	
	27.50(h)	B41	EIRP < 2Watt	
	90.635(b)	B26	ERP < 100Watt	
Peak-to-Average Ratio	22.913(d)	B5, B26	< 13 dB	PASS
	24.232(d)	B2, B25		
	27.50	B4, B12, B13, B41, B66, B71		
Occupied Bandwidth	2.1049	/	Reporting Only	PASS
Frequency Stability	2.1055	/	< 2.5 ppm	PASS
	22.355	B5, B26		
	24.235	B2, B25		
	27.54	B4, B12, B13, B41, B66, B71		
	90.213	B26		
Spurious Emission at Antenna Terminals	2.1051	/	< 43+10log10(P[Watts])	PASS
	22.917	B5, B26		
	24.238(a)	B2, B25		
	27.53(c)	B13		



	27.53(g)	B12, B71		
	27.53(h)	B4, B66		
	90.691	B26		
	27.53(m)	B41		
Band Edge	2.1051	/	Please refer to standard	PASS
	22.917	B5, B26		
	24.238(a)	B2, B25		
	27.53(c)	B13		
	27.53(g)	B12, B71		
	27.53(h)	B4, B66		
	27.53(m)	B41		
	90.691	B26		
Field Strength of Spurious Radiation	2.1053	/	< 43+10log10(P[Watts])	PASS
	22.917	B5, B26		
	24.238(a)	B2, B25		
	27.53(c)	B13		
	27.53(g)	B12, B71		
	27.53(h)	B4, B66		
	90.691	B26		
	27.53(m)	B41	< 55+10log10(P[Watts])	



1 INTRODUCTION

1.1 TEST FACTORY

SHENZHEN STS TEST SERVICES CO., LTD

Add. : 101, Building B, Zhuoke Science Park, No.190 Chongqing Road, ZhanChengShequ, Fuhai Sub-District, Bao'an District, Shenzhen, Guang Dong, China

FCC test Firm Registration Number: 625569

IC test Firm Registration Number: 12108A

A2LA Certificate No.: 4338.01

1.2 MEASUREMENT UNCERTAINTY

The measurement uncertainties shown below were calculated in accordance with the requirements of ANSI C63.4-2014. All measurement uncertainty values are shown with a coverage factor of $k = 2$ to indicate a 95% level of confidence. The measurement data shown herein meets or exceeds the CISPR measurement uncertainty values specified in CISPR 16-4-2 and, thus, can be compared directly to specified limits to determine compliance.

No.	Item	Uncertainty
1	RF output power, conducted	$\pm 0.755\text{dB}$
2	Unwanted Emissions, conducted	$\pm 2.874\text{dB}$
3	All emissions, radiated 9K-30MHz	$\pm 3.80\text{dB}$
4	All emissions, radiated 30M-1GHz	$\pm 4.18\text{dB}$
5	All emissions, radiated 1G-6GHz	$\pm 4.90\text{dB}$
6	All emissions, radiated >6G	$\pm 5.24\text{dB}$
7	Conducted Emission (9KHz-150KHz)	$\pm 2.19\text{dB}$
8	Conducted Emission (150KHz-30MHz)	$\pm 2.53\text{dB}$
9	Occupied Channel Bandwidth	$\pm 3.5\%$
10	Power Spectral Density, conducted	$\pm 1.245\text{dB}$
11	Duty Cycle	$\pm 3.2\%$



2 PRODUCT INFORMATION

Product Name	4G SMARTPHONE
Brand Name	SUNTAK
Model Name	MOJO
Series Model(s)	MOX 2
Model Difference	They only have different camera pixels, memory sizes, antennas, appearances, and everything else is exactly the same
Tx Frequency:	GSM850: 824-849 MHz GSM1900: 1850-1910 MHz LTE Band 2:1850~1910MHz LTE Band 4:1710~1755MHz LTE Band 5:824~849MHz LTE Band 12:699~716MHz LTE Band 13:777~787MHz LTE Band 25:1850~1915MHz LTE Band 26 Part 90:814~824MHz LTE Band 26 Part 22:824-849 MHz LTE Band 41: 2496-2690MHz LTE Band 66:1710~1780MHz LTE Band 71: 663-698 MHz
Rx Frequency:	GSM850: 8269-894 MHz GSM1900: 1930-1990 MHz LTE Band 2:1930 ~1990MHz LTE Band 4:2110~2155MHz LTE Band 5:869~894MHz LTE Band 12:729~746MHz LTE Band 13:746~756MHz LTE Band 25:1930~1995MHz LTE Band 26 Part 90:859~869MHz LTE Band 26 Part 22:869-894MHz LTE Band 41: 2496-2690MHz LTE Band 66:2110~2200MHz LTE Band 71: 617-652 MHz
Max RF Output Power:	GSM850:27.78dBm, PCS1900:26.8dBm LTE Band 2: 24.39 dBm,LTE Band 4: 23.71 dBm LTE Band 5: 24.20 dBm,LTE Band 12: 24.30 dBm LTE Band 13: 23.60 dBm,LTE Band 25: 23.52 dBm LTE Band 26 P22: 24.29 dBm,LTE Band 26 P90: 24.13 dBm LTE Band 41: 23.32dBm LTE Band 66: 24.31 dBm,LTE Band 71: 23.22 dBm
Modulation Characteristics:	GMSK for GSM/GPRS; GMSK and 8PSK for EDGE LTE: QPSK /16QAM
SIM Card:	SIM 1 and SIM 2 is a chipset unit and tested as single chipset, SIM 1 is used to tested.
Antenna:	PIFA
Antenna gain:	GSM 850: -0.42dBi ,PCS 1900:-0.25dBi, LTE B2: -0.25dBi,LTE B4: -0.31dBi LTE B5: -0.42dBi,LTE B12: -0.46dBi LTE B13: -0.67dBi,LTE B25: -0.34dBi LTE B26: -0.43dBi,LTE B41: -0.15dBi LTE B66: -0.29dBi,LTE B71: -0.72dBi



Battery parameter:	Rated Voltage: DC3.85V Charge Limit Voltage: 4.4V Capacity: 5000mAh
Adapter	Input: AC 100-240V, 0.3A,50/60Hz Output: DC 5V,2A
GPRS/EDGE Class:	Multi-Class12
Extreme Vol. Limits:	DC 3.2725V ~ DC 4.4275V (Normal: DC 3.85V)
Extreme Temp. Tolerance:	-30°C to +50°C
Hardware version number:	T341_9230_MB_D4F_V1.0
Software version number:	ROVER_MOJO_14_V01_20240426
<i>** Note: The High Voltage DC 4.4275V and Low Voltage DC 3.2725V was declared by manufacturer, The EUT couldn't be operate normally with higher or lower voltage, the antenna information refer the manufacturer provide report, applicable only to the tested sample identified in the report.</i>	

2.1 EMISSION DESIGNATOR

Mode	Emission Designator (99%OBW)	
GSM850	245KGXW	
GPRS850	248KGXW	
EGPRS850	252KG7W	
GSM1900	246KGXW	
GPRS1900	243KGXW	
EGPRS1900	249KG7W	
LTE Band 2 BW(MHz)	Emission Designator (99%OBW)QPSK	Emission Designator (99%OBW)16QAM
1.4	1M10G7D	1M10W7D
3	2M71G7D	2M72W7D
5	4M52G7D	4M52W7D
10	9M02G7D	9M01W7D
15	13M5G7D	13M5W7D
20	18M2G7D	18M1W7D
LTE Band 4 BW(MHz)	Emission Designator (99%OBW)QPSK	Emission Designator (99%OBW)16QAM
1.4	1M09G7D	1M10W7D
3	2M72G7D	2M71W7D
5	4M51G7D	4M54W7D
10	9M00G7D	9M00W7D
15	13M5G7D	13M5W7D
20	18M0G7D	18M0W7D
LTE Band 5 BW(MHz)	Emission Designator (99%OBW)QPSK	Emission Designator (99%OBW)16QAM
1.4	1M10G7D	1M11W7D
3	2M71G7D	2M71W7D
5	4M53G7D	4M53W7D
10	9M01G7D	8M98W7D
LTE Band 12 BW(MHz)	Emission Designator (99%OBW)QPSK	Emission Designator (99%OBW)16QAM
1.4	1M10G7D	1M11W7D
3	2M71G7D	2M71W7D
5	4M52G7D	4M50W7D
10	9M02G7D	9M00W7D
LTE Band 13 BW(MHz)	Emission Designator (99%OBW)QPSK	Emission Designator (99%OBW)16QAM
5	4M53G7D	4M53W7D
10	9M01G7D	9M00W7D
LTE Band 25 BW(MHz)	Emission Designator (99%OBW)QPSK	Emission Designator (99%OBW)16QAM
1.4	1M10G7D	1M10W7D
3	2M72G7D	2M71W7D
5	4M51G7D	4M52W7D
10	9M06G7D	9M01W7D
15	13M5G7D	13M5W7D
20	18M0G7D	18M0W7D



LTE Band 26	Emission Designator	Emission Designator
BW(MHz)	(99%OBW)QPSK	(99%OBW)16QAM
1.4	1M10G7D	1M10W7D
3	2M71G7D	2M71W7D
5	4M52G7D	4M53W7D
10	9M01G7D	9M01W7D
15	13M5G7D	13M5W7D
LTE Band 26	Emission Designator	Emission Designator
BW(MHz)	(99%OBW)QPSK	(99%OBW)16QAM
1.4	1M10G7D	1M10W7D
3	2M72G7D	2M72W7D
5	4M52G7D	4M51W7D
10	8M99G7D	8M99W7D
LTE Band 41	Emission Designator	Emission Designator
BW(MHz)	(99%OBW)QPSK	(99%OBW)16QAM
5	4M52G7D	4M51W7D
10	9M01G7D	9M00W7D
15	13M5G7D	13M5W7D
20	18M0G7D	18M0W7D
LTE Band 66	Emission Designator	Emission Designator
BW(MHz)	(99%OBW)QPSK	(99%OBW)16QAM
1.4	1M10G7D	1M10W7D
3	2M72G7D	2M72W7D
5	4M54G7D	4M53W7D
10	9M00G7D	9M02W7D
15	13M5G7D	13M5W7D
20	18M0G7D	18M0W7D
LTE Band 71	Emission Designator	Emission Designator
BW(MHz)	(99%OBW)QPSK	(99%OBW)16QAM
5	4M53G7D	4M52W7D
10	8M99G7D	9M00W7D
15	13M5G7D	13M5W7D
20	18M0G7D	18M0W7D



3 TEST CONFIGURATION OF EQUIPMENT UNDER TEST

Antenna port conducted and radiated test items were performed according to KDB 971168 D01 and ANSI C63.26 2015 Power Meas. License Digital Systems with maximum output power.

Radiated measurements were performed with rotating EUT in different three orthogonal test planes to find the maximum emission.

Radiated emissions were investigated as following frequency range:

1. 30 MHz to 10th harmonic for GSM850 and WCDMA Band V.
2. 30 MHz to 10th harmonic for WCDMA Band IV.
3. 30 MHz to 10th harmonic for GSM1900 and WCDMA Band II.

All modes and data rates and positions were investigated.

Test modes are chosen to be reported as the worst case configuration below:

	TEST MODES	
BAND	RADIATED TCS	CONDUCTED TCS
GSM 850	GSM LINK GPRS/EDGE CLASS 12 LINK	GSM LINK GPRS/EDGE CLASS 12 LINK
GSM 1900	GSM LINK GPRS/EDGE CLASS 12 LINK	GSM LINK GPRS/EDGE CLASS 12 LINK



LTE:

ITEMS	Band	Bandwidth (MHz)						Modulation		RB #			Test Channel		
		1.4	3	5	10	15	20	QPSK	16QAM	1	Half	Full	L	M	H
Max. Output Power	2	v	v	v	v	v	v	v	v	v	v	v	v	v	v
	4	v	v	v	v	v	v	v	v	v	v	v	v	v	v
	5	v	v	v	v			v	v	v	v	v	v	v	v
	12	v	v	v	v			v	v	v	v	v	v	v	v
	13			v	v			v	v	v	v	v		v	
	25	v	v	v	v	v	v	v	v	v	v	v	v	v	v
	26	v	v	v	v	v		v	v	v	v	v	v	v	v
	41			v	v	v	v	v	v	v	v	v	v	v	v
	66	v	v	v	v	v	v	v	v	v	v	v	v	v	v
	71			v	v	v	v	v	v	v	v	v	v	v	v
Peak&Avera Ratio	2	v	v	v	v	v	v	v	v	v			v	v	v
	4	v	v	v	v	v	v	v	v	v			v	v	v
	5	v	v	v	v			v	v	v			v	v	v
	12	v	v	v	v			v	v	v			v	v	v
	13			v	v			v	v	v				v	
	25	v	v	v	v	v	v	v	v	v			v	v	v
	26	v	v	v	v	v		v	v	v			v	v	v
	41			v	v	v	v	v	v	v			v	v	v
	66	v	v	v	v	v	v	v	v	v			v	v	v
	71			v	v	v	v	v	v	v			v	v	v
26dB&99% Bandwidth	2	v	v	v	v	v	v	v	v			v	v	v	v
	4	v	v	v	v	v	v	v	v			v	v	v	v
	5	v	v	v	v			v	v			v	v	v	v
	12	v	v	v	v			v	v			v	v	v	v
	13			v	v			v	v			v		v	
	25	v	v	v	v	v	v	v	v			v	v	v	v
	26	v	v	v	v	v		v	v			v	v	v	v
	41			v	v	v	v	v	v			v	v	v	v
	66	v	v	v	v	v	v	v	v			v	v	v	v
	71			v	v	v	v	v	v			v	v	v	v
Conducted Band Edge	2	v	v	v	v	v	v	v	v			v	v		v
	4	v	v	v	v	v	v	v	v			v	v		v
	5	v	v	v	v			v	v			v	v		v
	12	v	v	v	v			v	v			v	v		v
	13			v	v			v	v			v		v	
	25	v	v	v	v	v	v	v	v			v	v		v
	26	v	v	v	v	v		v	v			v	v		v
	41			v	v	v	v	v	v			v	v		v
	66	v	v	v	v	v	v	v	v			v	v		v
	71			v	v	v	v	v	v			v	v		v



Conducted Spurious Emission	2	v	v	v	v	v	v	v	v	v		v	v	v	v
	4	v	v	v	v	v	v	v	v	v		v	v	v	v
	5	v	v	v	v			v	v	v		v	v	v	v
	12	v	v	v	v			v	v	v		v	v	v	v
	13			v	v			v	v	v		v		v	
	25	v	v	v	v	v	v	v	v	v		v	v	v	v
	26	v	v	v	v	v		v	v	v		v	v	v	v
	41			v	v	v	v	v	v	v		v	v	v	v
	66	v	v	v	v	v	v	v	v	v		v	v	v	v
	71			v	v	v	v	v	v	v		v	v	v	v
Frequency Stability	2				v			v				v		v	
	4				v			v				v		v	
	5				v			v				v		v	
	12				v			v				v		v	
	13				v			v				v		v	
	25				v			v				v		v	
	26				v			v				v		v	
	41				v			v				v		v	
	66				v			v				v		v	
	71				v			v				v		v	
E.R.P.& E.I.R.P.	2	v	v	v	v	v	v	v	v	v	v	v	v	v	v
	4	v	v	v	v	v	v	v	v	v	v	v	v	v	v
	5	v	v	v	v			v	v	v	v	v	v	v	v
	12	v	v	v	v			v	v	v	v	v	v	v	v
	13			v	v			v	v	v	v	v		v	
	25	v	v	v	v	v	v	v	v	v	v	v	v	v	v
	26	v	v	v	v	v		v	v	v	v	v	v	v	v
	41			v	v	v	v	v	v	v	v	v	v	v	v
	66	v	v	v	v	v	v	v	v	v	v	v	v	v	v
	71			v	v	v	v	v	v	v	v	v	v	v	v
Radiated Spurious Emission	2	v	v	v	v	v	v	v		v			v	v	v
	4	v	v	v	v	v	v	v		v			v	v	v
	5	v	v	v	v			v		v			v	v	v
	12	v	v	v	v			v		v			v	v	v
	13			v	v			v		v				v	
	25	v	v	v	v	v	v	v		v			v	v	v
	26	v	v	v	v	v		v		v			v	v	v
	41			v	v	v	v	v		v			v	v	v
	66	v	v	v	v	v	v	v		v			v	v	v
	71			v	v	v	v	v		v			v	v	v



4 MEASUREMENT INSTRUMENTS

RF Radiation Test Equipment					
Kind of Equipment	Manufacturer	Type No.	Serial No.	Last Calibration	Calibrated Until
Temperature & Humidity	SW-108	SuWei	N/A	2024.03.15	2025.03.14
Wireless Communications Test Set	R&S	CMW 500	117239	2023.09.26	2024.09.25
Pre-Amplifier(0.1M-3GHz)	EM	EM330	060665	2024.02.23	2025.02.22
Pre-Amplifier (1G-18GHz)	SKET	LNPA-01018G-45	SK2018080901	2023.09.26	2024.09.25
Positioning Controller	MF	MF-7802	MF-780208587	N/A	N/A
Signal Analyzer	R&S	FSV 40-N	101823	2023.09.26	2024.09.25
Switch Control Box	N/A	N/A	N/A	N/A	N/A
Filter Box	BALUN Technology	SU319E	BL-SZ1530051	N/A	N/A
Video Controller	SKET	FCS C-3	N/A	N/A	N/A
Bilog Antenna	TESEQ	CBL6111D	34678	2022.09.30	2024.09.29
Horn Antenna	SCHWARZBECK	BBHA 9120D	02014	2023.09.24	2025.09.23
Antenna Mast	MF	MFA-440H	N/A	N/A	N/A
Turn Table	MF	N/A	N/A	N/A	N/A
AC Power Source	APC	KDF-11010G	F214050035	N/A	N/A
DC Power Supply	Zhaoxin	RXN 605D	20R605D11010081	N/A	N/A
Test SW	EMC Test Software	15.2.0.339			
	EZ-EMC	Ver.STSLAB-03A1 RE			
RF Connected Test Equipment					
Kind of Equipment	Manufacturer	Type No.	Serial No.	Last Calibration	Calibrated Until
Temperature & Humidity	SW-108	SuWei	N/A	2024.03.15	2025.03.14
Wireless Communications Test Set	R&S	CMW 500	131428	2024.02.23	2025.02.22
Signal Analyzer	Agilent	N9020A	MY52440124	2024.02.23	2025.02.22
RF Automatic Test System	Maiwei	MW200-SFCB	N/A	N/A	N/A
Temperature & Humidity Test Chamber	Safety test	AG80L	171200018	2024.02.23	2025.02.22
Programmable Power Supply	Agilent	E3642A	MY40002025	2023.09.26	2024.09.25
Test SW	MTS 8200	2.0.0.0			

5 TEST ITEMS

5.1 CONDUCTED OUTPUT POWER&TRANSMITTER RADIATED POWER

TEST OVERVIEW

CONDUCTED OUTPUT POWER:

A system simulator was used to establish communication with the EUT. Its parameters were set to enforce EUT transmitting at the maximum power. The measured power in the radio frequency on the transmitter output terminals shall be reported.

TRANSMITTER RADIATED POWER (EIRP/ERP)

Determining ERP and/or EIRP from conducted RF output power measurements according to ANSI C63.26 2015 Section 5.2.5.5.

In many cases, RF output power limits are specified in terms of the ERP or the EIRP. Typically, ERP is specified when the operating frequency is less than or equal to 1 GHz and EIRP is specified when the operating frequency is greater than 1 GHz. Both are defined as the product of the power supplied to the antenna and its gain (relative to a dipole antenna in the case of ERP, and relative to an isotropic antenna in the case of EIRP); however, when working in decibels (i.e., logarithmic scale), the ERP and EIRP represent the sum of the transmit antenna gain (in dBd or dBi, respectively) and the conducted RF output power (expressed in dB relative to watts or milliwatts).

The relevant equation for determining the maximum ERP or EIRP from the measured RF output power is given in Equation (1) as follows:

$$(1) \text{ ERP or EIRP} = P_{\text{Meas}} + GT$$
$$\text{ERP} = \text{EIRP} - 2.15$$

where

ERP or EIRP effective radiated power or equivalent isotropically radiated power, respectively (expressed in the same units as P_{Meas} , e.g., dBm or dBW)

P_{Meas} measured transmitter output power or PSD, in dBm or dBW

GT gain of the transmitting antenna, in dBd (ERP) or dBi (EIRP)

For devices utilizing multiple antennas, see 6.4 for guidance with respect to determining the effective array transmit antenna gain term to be used in the above equation.

The following equations demonstrate the mathematical relationship between ERP and EIRP:

- ERP = EIRP - 2.15, where ERP and EIRP are expressed in consistent units.
- EIRP = ERP + 2.15, where ERP and EIRP are expressed in consistent units.

TEST PROCEDURES

1. The transmitter output port was connected to the system simulator.
2. Set eut at maximum power through the system simulator.
3. Select lowest, middle, and highest channels for each band and different modulation.
4. Measure and record the power level from the system simulator.

TEST SETUP

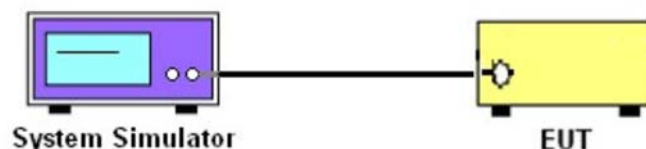

TEST RESULT

GSM 850							
Mode	Frequency (MHz)	Conduction AVG Power(dBm)	Ant Gain (dBi)	ERP (dBm)	ERP Limit (W)	ERP Limit (dBm)	Conclusion
GSM (GMSK,1-Slot)	824.2	30.35	-0.42	27.78	7.00	38.45	PASS
	836.6	30.26	-0.42	27.69	7.00	38.45	PASS
	848.8	30.31	-0.42	27.74	7.00	38.45	PASS
GPRS (GMSK,1-Slot)	824.2	30.28	-0.42	27.71	7.00	38.45	PASS
	836.6	30.25	-0.42	27.68	7.00	38.45	PASS
	848.8	30.28	-0.42	27.71	7.00	38.45	PASS
GPRS (GMSK,2-Slot)	824.2	28.13	-0.42	25.56	7.00	38.45	PASS
	836.6	28.07	-0.42	25.50	7.00	38.45	PASS
	848.8	28.23	-0.42	25.66	7.00	38.45	PASS
GPRS (GMSK,3-Slot)	824.2	26.19	-0.42	23.62	7.00	38.45	PASS
	836.6	26.15	-0.42	23.58	7.00	38.45	PASS
	848.8	26.28	-0.42	23.71	7.00	38.45	PASS
GPRS (GMSK,4-Slot)	824.2	24.16	-0.42	21.59	7.00	38.45	PASS
	836.6	24.07	-0.42	21.50	7.00	38.45	PASS
	848.8	24.17	-0.42	21.60	7.00	38.45	PASS
EGPRS (8PSK,1-Slot)	824.2	23.77	-0.42	21.20	7.00	38.45	PASS
	836.6	23.28	-0.42	20.71	7.00	38.45	PASS
	848.8	23.38	-0.42	20.81	7.00	38.45	PASS
EGPRS (8PSK,2-Slot)	824.2	22.64	-0.42	20.07	7.00	38.45	PASS
	836.6	22.49	-0.42	19.92	7.00	38.45	PASS
	848.8	22.48	-0.42	19.91	7.00	38.45	PASS
EGPRS (8PSK,3-Slot)	824.2	20.31	-0.42	17.74	7.00	38.45	PASS
	836.6	19.87	-0.42	17.30	7.00	38.45	PASS
	848.8	19.93	-0.42	17.36	7.00	38.45	PASS
EGPRS (8PSK,4-Slot)	824.2	18.06	-0.42	15.49	7.00	38.45	PASS
	836.6	18.12	-0.42	15.55	7.00	38.45	PASS
	848.8	17.67	-0.42	15.10	7.00	38.45	PASS



PCS 1900							
Mode	Frequency (MHz)	Conduction AVG Power(dBm)	Ant Gain (dBi)	EIRP (dBm)	EIRP Limit (W)	EIRP Limit (dBm)	Conclusion
GSM (GMSK,1-Slot)	1850.2	27.05	-0.25	26.80	2.00	33.01	PASS
	1880.0	27	-0.25	26.75	2.00	33.01	PASS
	1909.8	26.76	-0.25	26.51	2.00	33.01	PASS
GPRS (GMSK,1-Slot)	1850.2	26.96	-0.25	26.71	2.00	33.01	PASS
	1880.0	26.89	-0.25	26.64	2.00	33.01	PASS
	1909.8	26.70	-0.25	26.45	2.00	33.01	PASS
GPRS (GMSK,2-Slot)	1850.2	24.96	-0.25	24.71	2.00	33.01	PASS
	1880.0	24.69	-0.25	24.44	2.00	33.01	PASS
	1909.8	24.25	-0.25	24.00	2.00	33.01	PASS
GPRS (GMSK,3-Slot)	1850.2	23.44	-0.25	23.19	2.00	33.01	PASS
	1880.0	23.12	-0.25	22.87	2.00	33.01	PASS
	1909.8	22.73	-0.25	22.48	2.00	33.01	PASS
GPRS (GMSK,4-Slot)	1850.2	21.21	-0.25	20.96	2.00	33.01	PASS
	1880.0	21.01	-0.25	20.76	2.00	33.01	PASS
	1909.8	20.60	-0.25	20.35	2.00	33.01	PASS
EGPRS (8PSK,1-Slot)	1850.2	24.35	-0.25	24.10	2.00	33.01	PASS
	1880.0	23.78	-0.25	23.53	2.00	33.01	PASS
	1909.8	23.39	-0.25	23.14	2.00	33.01	PASS
EGPRS (8PSK,2-Slot)	1850.2	22.41	-0.25	22.16	2.00	33.01	PASS
	1880.0	22.43	-0.25	22.18	2.00	33.01	PASS
	1909.8	21.64	-0.25	21.39	2.00	33.01	PASS
EGPRS (8PSK,3-Slot)	1850.2	20.30	-0.25	20.05	2.00	33.01	PASS
	1880.0	20.13	-0.25	19.88	2.00	33.01	PASS
	1909.8	20.11	-0.25	19.86	2.00	33.01	PASS
EGPRS (8PSK,4-Slot)	1850.2	18.21	-0.25	17.96	2.00	33.01	PASS
	1880.0	18.32	-0.25	18.07	2.00	33.01	PASS
	1909.8	17.93	-0.25	17.68	2.00	33.01	PASS



Radiated Power (EIRP) for LTE Band 2 /1.4M										
BW (MHz)	UL Channel	RB Size	RB offset	Modulation	Conduction AVG Power(dBm)	Ant Gain (dBi)	EIRP (dBm)	EIRP Limit(W)	EIRP Limit(dBm)	Verdict
1.4	Lowest	1	0	QPSK	23.8	-0.25	23.55	2.00	33.01	PASS
		1	2		23.88	-0.25	23.63	2.00	33.01	PASS
		1	5		23.85	-0.25	23.60	2.00	33.01	PASS
		3	0		23.86	-0.25	23.61	2.00	33.01	PASS
		3	1		23.9	-0.25	23.65	2.00	33.01	PASS
		3	2		23.82	-0.25	23.57	2.00	33.01	PASS
		6	0	22.84	-0.25	22.59	2.00	33.01	PASS	
		1	0	16QAM	23.55	-0.25	23.30	2.00	33.01	PASS
		1	2		23.55	-0.25	23.30	2.00	33.01	PASS
		1	5		23.61	-0.25	23.36	2.00	33.01	PASS
		3	0		22.96	-0.25	22.71	2.00	33.01	PASS
		3	1		23	-0.25	22.75	2.00	33.01	PASS
		3	2		23.03	-0.25	22.78	2.00	33.01	PASS
		6	0	22.08	-0.25	21.83	2.00	33.01	PASS	
		1	0	QPSK	24.11	-0.25	23.86	2.00	33.01	PASS
		1	2		24.22	-0.25	23.97	2.00	33.01	PASS
		1	5		24.13	-0.25	23.88	2.00	33.01	PASS
		3	0		24	-0.25	23.75	2.00	33.01	PASS
	3	1	24.09		-0.25	23.84	2.00	33.01	PASS	
	3	2	24.01		-0.25	23.76	2.00	33.01	PASS	
	6	0	22.99	-0.25	22.74	2.00	33.01	PASS		
	1	0	16QAM	23.05	-0.25	22.80	2.00	33.01	PASS	
	1	2		22.78	-0.25	22.53	2.00	33.01	PASS	
	1	5		22.82	-0.25	22.57	2.00	33.01	PASS	
	3	0		23.06	-0.25	22.81	2.00	33.01	PASS	
	3	1		23.1	-0.25	22.85	2.00	33.01	PASS	
	3	2		23.04	-0.25	22.79	2.00	33.01	PASS	
	6	0	22.2	-0.25	21.95	2.00	33.01	PASS		
	1	0	QPSK	24.27	-0.25	24.02	2.00	33.01	PASS	
	1	2		24.23	-0.25	23.98	2.00	33.01	PASS	
	1	5		24.23	-0.25	23.98	2.00	33.01	PASS	
	3	0		23.99	-0.25	23.74	2.00	33.01	PASS	
	3	1		23.93	-0.25	23.68	2.00	33.01	PASS	
	3	2		24.01	-0.25	23.76	2.00	33.01	PASS	
	6	0	22.88	-0.25	22.63	2.00	33.01	PASS		
	1	0	16QAM	23.71	-0.25	23.46	2.00	33.01	PASS	
	1	2		23.76	-0.25	23.51	2.00	33.01	PASS	
	1	5		23.76	-0.25	23.51	2.00	33.01	PASS	
	3	0		22.92	-0.25	22.67	2.00	33.01	PASS	
	3	1		22.97	-0.25	22.72	2.00	33.01	PASS	
	3	2		23	-0.25	22.75	2.00	33.01	PASS	
	6	0	22.08	-0.25	21.83	2.00	33.01	PASS		



Radiated Power (EIRP) for LTE Band 2 /3M										
BW (MHz)	UL Channel	RB Size	RB offset	Modulation	Conduction AVG Power(dBm)	Ant Gain (dBi)	EIRP (dBm)	EIRP Limit(W)	EIRP Limit(dBm)	Verdict
3	Lowest	1	0	QPSK	24.1	-0.25	23.85	2.00	33.01	PASS
		1	7		24.14	-0.25	23.89	2.00	33.01	PASS
		1	14		24.02	-0.25	23.77	2.00	33.01	PASS
		8	0		22.85	-0.25	22.60	2.00	33.01	PASS
		8	4		22.81	-0.25	22.56	2.00	33.01	PASS
		8	7		22.73	-0.25	22.48	2.00	33.01	PASS
		15	0	22.88	-0.25	22.63	2.00	33.01	PASS	
		1	0	22.69	-0.25	22.44	2.00	33.01	PASS	
		1	7	22.6	-0.25	22.35	2.00	33.01	PASS	
		1	14	22.54	-0.25	22.29	2.00	33.01	PASS	
		8	0	22.09	-0.25	21.84	2.00	33.01	PASS	
		8	4	22.04	-0.25	21.79	2.00	33.01	PASS	
		8	7	21.9	-0.25	21.65	2.00	33.01	PASS	
		15	0	21.81	-0.25	21.56	2.00	33.01	PASS	
		Middle	1	0	QPSK	23.99	-0.25	23.74	2.00	33.01
	1		7	24.07		-0.25	23.82	2.00	33.01	PASS
	1		14	23.97		-0.25	23.72	2.00	33.01	PASS
	8		0	23.04		-0.25	22.79	2.00	33.01	PASS
	8		4	23.01		-0.25	22.76	2.00	33.01	PASS
	8		7	22.99		-0.25	22.74	2.00	33.01	PASS
	15		0	22.99	-0.25	22.74	2.00	33.01	PASS	
	1		0	22.93	-0.25	22.68	2.00	33.01	PASS	
	1		7	23	-0.25	22.75	2.00	33.01	PASS	
	1		14	23.19	-0.25	22.94	2.00	33.01	PASS	
	8		0	22	-0.25	21.75	2.00	33.01	PASS	
	8		4	22	-0.25	21.75	2.00	33.01	PASS	
	8		7	22	-0.25	21.75	2.00	33.01	PASS	
	15		0	22.05	-0.25	21.80	2.00	33.01	PASS	
	Highest		1	0	QPSK	24.26	-0.25	24.01	2.00	33.01
		1	7	24.27		-0.25	24.02	2.00	33.01	PASS
		1	14	24.19		-0.25	23.94	2.00	33.01	PASS
		8	0	22.92		-0.25	22.67	2.00	33.01	PASS
		8	4	22.86		-0.25	22.61	2.00	33.01	PASS
		8	7	22.92		-0.25	22.67	2.00	33.01	PASS
		15	0	22.94	-0.25	22.69	2.00	33.01	PASS	
		1	0	23.25	-0.25	23.00	2.00	33.01	PASS	
1		7	23.07	-0.25	22.82	2.00	33.01	PASS		
1		14	23.3	-0.25	23.05	2.00	33.01	PASS		
8		0	22	-0.25	21.75	2.00	33.01	PASS		
8		4	22.09	-0.25	21.84	2.00	33.01	PASS		
8		7	22.25	-0.25	22.00	2.00	33.01	PASS		
15		0	22.17	-0.25	21.92	2.00	33.01	PASS		



Radiated Power (EIRP) for LTE Band 2 /5M										
BW (MHz)	UL Channel	RB Size	RB offset	Modulation	Conduction AVG Power(dBm)	Ant Gain (dBi)	EIRP (dBm)	EIRP Limit(W)	EIRP Limit(dBm)	Verdict
5	Lowest	1	0	QPSK	23.75	-0.25	23.50	2.00	33.01	PASS
		1	12		23.63	-0.25	23.38	2.00	33.01	PASS
		1	24		23.7	-0.25	23.45	2.00	33.01	PASS
		12	0		22.85	-0.25	22.60	2.00	33.01	PASS
		12	6		22.79	-0.25	22.54	2.00	33.01	PASS
		12	11		22.73	-0.25	22.48	2.00	33.01	PASS
		25	0		22.8	-0.25	22.55	2.00	33.01	PASS
		1	0	16QAM	22.77	-0.25	22.52	2.00	33.01	PASS
		1	12		22.7	-0.25	22.45	2.00	33.01	PASS
		1	24		22.61	-0.25	22.36	2.00	33.01	PASS
		12	0		21.89	-0.25	21.64	2.00	33.01	PASS
		12	6		21.75	-0.25	21.50	2.00	33.01	PASS
		12	11		21.79	-0.25	21.54	2.00	33.01	PASS
		25	0		21.96	-0.25	21.71	2.00	33.01	PASS
	Middle	QPSK	1	0	24.19	-0.25	23.94	2.00	33.01	PASS
			1	12	24.18	-0.25	23.93	2.00	33.01	PASS
			1	24	24.13	-0.25	23.88	2.00	33.01	PASS
			12	0	22.96	-0.25	22.71	2.00	33.01	PASS
			12	6	22.96	-0.25	22.71	2.00	33.01	PASS
			12	11	22.91	-0.25	22.66	2.00	33.01	PASS
			25	0	22.92	-0.25	22.67	2.00	33.01	PASS
		16QAM	1	0	23.12	-0.25	22.87	2.00	33.01	PASS
			1	12	23.08	-0.25	22.83	2.00	33.01	PASS
			1	24	23.18	-0.25	22.93	2.00	33.01	PASS
			12	0	22.02	-0.25	21.77	2.00	33.01	PASS
			12	6	22	-0.25	21.75	2.00	33.01	PASS
			12	11	21.93	-0.25	21.68	2.00	33.01	PASS
			25	0	21.94	-0.25	21.69	2.00	33.01	PASS
	Highest	QPSK	1	0	23.86	-0.25	23.61	2.00	33.01	PASS
			1	12	23.86	-0.25	23.61	2.00	33.01	PASS
			1	24	24.12	-0.25	23.87	2.00	33.01	PASS
			12	0	23.01	-0.25	22.76	2.00	33.01	PASS
			12	6	22.93	-0.25	22.68	2.00	33.01	PASS
			12	11	23	-0.25	22.75	2.00	33.01	PASS
			25	0	22.96	-0.25	22.71	2.00	33.01	PASS
		16QAM	1	0	22.58	-0.25	22.33	2.00	33.01	PASS
1			12	22.81	-0.25	22.56	2.00	33.01	PASS	
1			24	23.12	-0.25	22.87	2.00	33.01	PASS	
12			0	22.05	-0.25	21.80	2.00	33.01	PASS	
12			6	22.08	-0.25	21.83	2.00	33.01	PASS	
12			11	22.11	-0.25	21.86	2.00	33.01	PASS	
25			0	21.98	-0.25	21.73	2.00	33.01	PASS	



Radiated Power (EIRP) for LTE Band 2 /10M										
BW (MHz)	UL Channel	RB Size	RB offset	Modulation	Conduction AVG Power(dBm)	Ant Gain (dBi)	EIRP (dBm)	EIRP Limit(W)	EIRP Limit(dBm)	Verdict
10	Lowest	1	0	QPSK	24.17	-0.25	23.92	2.00	33.01	PASS
		1	24		24	-0.25	23.75	2.00	33.01	PASS
		1	49		24.01	-0.25	23.76	2.00	33.01	PASS
		25	0		22.77	-0.25	22.52	2.00	33.01	PASS
		25	12		22.76	-0.25	22.51	2.00	33.01	PASS
		25	24		22.73	-0.25	22.48	2.00	33.01	PASS
		50	0	22.83	-0.25	22.58	2.00	33.01	PASS	
		1	0	16QAM	22.72	-0.25	22.47	2.00	33.01	PASS
		1	24		22.58	-0.25	22.33	2.00	33.01	PASS
		1	49		22.58	-0.25	22.33	2.00	33.01	PASS
		25	0		21.9	-0.25	21.65	2.00	33.01	PASS
		25	12		21.8	-0.25	21.55	2.00	33.01	PASS
		25	24		21.85	-0.25	21.60	2.00	33.01	PASS
		50	0	21.81	-0.25	21.56	2.00	33.01	PASS	
		1	0	QPSK	24.02	-0.25	23.77	2.00	33.01	PASS
	1	24	24.03		-0.25	23.78	2.00	33.01	PASS	
	1	49	23.97		-0.25	23.72	2.00	33.01	PASS	
	25	0	22.95		-0.25	22.70	2.00	33.01	PASS	
	25	12	22.98		-0.25	22.73	2.00	33.01	PASS	
	25	24	22.95		-0.25	22.70	2.00	33.01	PASS	
	50	0	22.94	-0.25	22.69	2.00	33.01	PASS		
	1	0	16QAM	23.54	-0.25	23.29	2.00	33.01	PASS	
	1	24		23.6	-0.25	23.35	2.00	33.01	PASS	
	1	49		23.62	-0.25	23.37	2.00	33.01	PASS	
	25	0		22.08	-0.25	21.83	2.00	33.01	PASS	
	25	12		22.04	-0.25	21.79	2.00	33.01	PASS	
	25	24		22.12	-0.25	21.87	2.00	33.01	PASS	
	50	0	22.03	-0.25	21.78	2.00	33.01	PASS		
	1	0	QPSK	24.17	-0.25	23.92	2.00	33.01	PASS	
	1	24		24.2	-0.25	23.95	2.00	33.01	PASS	
	1	49		24.23	-0.25	23.98	2.00	33.01	PASS	
	25	0		22.94	-0.25	22.69	2.00	33.01	PASS	
	25	12		23.05	-0.25	22.80	2.00	33.01	PASS	
	25	24		22.94	-0.25	22.69	2.00	33.01	PASS	
	50	0	23.03	-0.25	22.78	2.00	33.01	PASS		
	1	0	16QAM	23.03	-0.25	22.78	2.00	33.01	PASS	
	1	24		23.09	-0.25	22.84	2.00	33.01	PASS	
	1	49		23.17	-0.25	22.92	2.00	33.01	PASS	
	25	0		22.17	-0.25	21.92	2.00	33.01	PASS	
	25	12		22.17	-0.25	21.92	2.00	33.01	PASS	
	25	24		22.13	-0.25	21.88	2.00	33.01	PASS	
	50	0	22.18	-0.25	21.93	2.00	33.01	PASS		



Radiated Power (EIRP) for LTE Band 2 /15M										
BW (MHz)	UL Channel	RB Size	RB offset	Modulation	Conduction AVG Power(dBm)	Ant Gain (dBi)	EIRP (dBm)	EIRP Limit(W)	EIRP Limit(dBm)	Verdict
15	Lowest	1	0	QPSK	22.65	-0.25	22.40	2.00	33.01	PASS
		1	37		21.92	-0.25	21.67	2.00	33.01	PASS
		1	74		23.58	-0.25	23.33	2.00	33.01	PASS
		36	0		23.25	-0.25	23.00	2.00	33.01	PASS
		36	18		21.9	-0.25	21.65	2.00	33.01	PASS
		36	39		22.71	-0.25	22.46	2.00	33.01	PASS
		75	0	23.05	-0.25	22.80	2.00	33.01	PASS	
		1	0	16QAM	22.95	-0.25	22.70	2.00	33.01	PASS
		1	37		23.31	-0.25	23.06	2.00	33.01	PASS
		1	74		23.36	-0.25	23.11	2.00	33.01	PASS
		36	0		21.96	-0.25	21.71	2.00	33.01	PASS
		36	18		21.86	-0.25	21.61	2.00	33.01	PASS
		36	39		21.91	-0.25	21.66	2.00	33.01	PASS
		75	0	21.91	-0.25	21.66	2.00	33.01	PASS	
	Middle	QPSK	1	0	24.16	-0.25	23.91	2.00	33.01	PASS
			1	37	24.26	-0.25	24.01	2.00	33.01	PASS
			1	74	24.18	-0.25	23.93	2.00	33.01	PASS
			36	0	22.91	-0.25	22.66	2.00	33.01	PASS
			36	18	22.97	-0.25	22.72	2.00	33.01	PASS
			36	39	22.95	-0.25	22.70	2.00	33.01	PASS
		75	0	22.92	-0.25	22.67	2.00	33.01	PASS	
		16QAM	1	0	22.75	-0.25	22.50	2.00	33.01	PASS
			1	37	22.91	-0.25	22.66	2.00	33.01	PASS
			1	74	23.03	-0.25	22.78	2.00	33.01	PASS
			36	0	22.06	-0.25	21.81	2.00	33.01	PASS
			36	18	22	-0.25	21.75	2.00	33.01	PASS
			36	39	22.03	-0.25	21.78	2.00	33.01	PASS
			75	0	22.07	-0.25	21.82	2.00	33.01	PASS
	Highest		QPSK	1	0	24.2	-0.25	23.95	2.00	33.01
		1		37	24.27	-0.25	24.02	2.00	33.01	PASS
		1		74	24.38	-0.25	24.13	2.00	33.01	PASS
		36		0	22.9	-0.25	22.65	2.00	33.01	PASS
		36		18	23.06	-0.25	22.81	2.00	33.01	PASS
		36		39	23.04	-0.25	22.79	2.00	33.01	PASS
		75	0	23.05	-0.25	22.80	2.00	33.01	PASS	
		16QAM	1	0	22.73	-0.25	22.48	2.00	33.01	PASS
1			37	22.81	-0.25	22.56	2.00	33.01	PASS	
1			74	22.83	-0.25	22.58	2.00	33.01	PASS	
36			0	22	-0.25	21.75	2.00	33.01	PASS	
36			18	22.12	-0.25	21.87	2.00	33.01	PASS	
36			39	22.1	-0.25	21.85	2.00	33.01	PASS	
75			0	22.17	-0.25	21.92	2.00	33.01	PASS	



Radiated Power (EIRP) for LTE Band 2 /20M										
BW (MHz)	UL Channel	RB Size	RB offset	Modulation	Conduction AVG Power(dBm)	Ant Gain (dBi)	EIRP (dBm)	EIRP Limit(W)	EIRP Limit(dBm)	Verdict
20	Lowest	1	0	QPSK	24.06	-0.25	23.81	2.00	33.01	PASS
		1	49		23.98	-0.25	23.73	2.00	33.01	PASS
		1	99		24.11	-0.25	23.86	2.00	33.01	PASS
		50	0		22.75	-0.25	22.50	2.00	33.01	PASS
		50	24		22.84	-0.25	22.59	2.00	33.01	PASS
		50	49		22.89	-0.25	22.64	2.00	33.01	PASS
		100	0	22.84	-0.25	22.59	2.00	33.01	PASS	
		1	0	16QAM	23.14	-0.25	22.89	2.00	33.01	PASS
		1	49		23.08	-0.25	22.83	2.00	33.01	PASS
		1	99		23.17	-0.25	22.92	2.00	33.01	PASS
		50	0		21.96	-0.25	21.71	2.00	33.01	PASS
		50	24		21.96	-0.25	21.71	2.00	33.01	PASS
		50	49		22.07	-0.25	21.82	2.00	33.01	PASS
		100	0	21.91	-0.25	21.66	2.00	33.01	PASS	
		1	0	QPSK	24.27	-0.25	24.02	2.00	33.01	PASS
	1	49	24.39		-0.25	24.14	2.00	33.01	PASS	
	1	99	24.25		-0.25	24.00	2.00	33.01	PASS	
	50	0	23.02		-0.25	22.77	2.00	33.01	PASS	
	50	24	23.07		-0.25	22.82	2.00	33.01	PASS	
	50	49	23.03		-0.25	22.78	2.00	33.01	PASS	
	100	0	22.95	-0.25	22.70	2.00	33.01	PASS		
	1	0	16QAM	23.07	-0.25	22.82	2.00	33.01	PASS	
	1	49		23.11	-0.25	22.86	2.00	33.01	PASS	
	1	99		23.05	-0.25	22.80	2.00	33.01	PASS	
	50	0		22.07	-0.25	21.82	2.00	33.01	PASS	
	50	24		22.06	-0.25	21.81	2.00	33.01	PASS	
	50	49		22.05	-0.25	21.80	2.00	33.01	PASS	
	100	0	22.1	-0.25	21.85	2.00	33.01	PASS		
	1	0	QPSK	24	-0.25	23.75	2.00	33.01	PASS	
	1	49		24.08	-0.25	23.83	2.00	33.01	PASS	
	1	99		24.27	-0.25	24.02	2.00	33.01	PASS	
	50	0		23	-0.25	22.75	2.00	33.01	PASS	
	50	24		22.95	-0.25	22.70	2.00	33.01	PASS	
	50	49		22.99	-0.25	22.74	2.00	33.01	PASS	
	100	0	22.97	-0.25	22.72	2.00	33.01	PASS		
	1	0	16QAM	23.59	-0.25	23.34	2.00	33.01	PASS	
	1	49		23.42	-0.25	23.17	2.00	33.01	PASS	
	1	99		23.45	-0.25	23.20	2.00	33.01	PASS	
	50	0		22.12	-0.25	21.87	2.00	33.01	PASS	
	50	24		22.06	-0.25	21.81	2.00	33.01	PASS	
	50	49		22.16	-0.25	21.91	2.00	33.01	PASS	
	100	0	22.06	-0.25	21.81	2.00	33.01	PASS		



Radiated Power (EIRP) for LTE Band 4 /1.4M											
BW (MHz)	UL Channel	RB Size	RB offset	Modulation	Conduction AVG Power(dBm)	Ant Gain (dBi)	EIRP (dBm)	EIRP Limit(W)	EIRP Limit(dBm)	Verdict	
1.4	Lowest	1	0	QPSK	23.47	-0.31	23.16	1.00	30.00	PASS	
		1	2		23.43	-0.31	23.12	1.00	30.00	PASS	
		1	5		23.51	-0.31	23.20	1.00	30.00	PASS	
		3	0		23.25	-0.31	22.94	1.00	30.00	PASS	
		3	1		23.28	-0.31	22.97	1.00	30.00	PASS	
		3	2		23.25	-0.31	22.94	1.00	30.00	PASS	
		6	0	22.23	-0.31	21.92	1.00	30.00	PASS		
		1	0	16QAM	23.14	-0.31	22.83	1.00	30.00	PASS	
		1	2		23.21	-0.31	22.90	1.00	30.00	PASS	
		1	5		23.2	-0.31	22.89	1.00	30.00	PASS	
		3	0		22.4	-0.31	22.09	1.00	30.00	PASS	
		3	1		22.4	-0.31	22.09	1.00	30.00	PASS	
		3	2		22.37	-0.31	22.06	1.00	30.00	PASS	
		6	0	21.33	-0.31	21.02	1.00	30.00	PASS		
		Middle	QPSK	1	0	23.58	-0.31	23.27	1.00	30.00	PASS
	1			2	23.57	-0.31	23.26	1.00	30.00	PASS	
	1			5	23.55	-0.31	23.24	1.00	30.00	PASS	
	3			0	23.36	-0.31	23.05	1.00	30.00	PASS	
	3			1	23.24	-0.31	22.93	1.00	30.00	PASS	
	3			2	23.31	-0.31	23.00	1.00	30.00	PASS	
	6		0	22.33	-0.31	22.02	1.00	30.00	PASS		
	16QAM		1	0	22.92	-0.31	22.61	1.00	30.00	PASS	
			1	2	23.53	-0.31	23.22	1.00	30.00	PASS	
			1	5	23.46	-0.31	23.15	1.00	30.00	PASS	
			3	0	22.52	-0.31	22.21	1.00	30.00	PASS	
			3	1	22.49	-0.31	22.18	1.00	30.00	PASS	
			3	2	22.3	-0.31	21.99	1.00	30.00	PASS	
			6	0	21.41	-0.31	21.10	1.00	30.00	PASS	
			Highest	QPSK	1	0	22.99	-0.31	22.68	1.00	30.00
		1			2	22.88	-0.31	22.57	1.00	30.00	PASS
	1	5			22.9	-0.31	22.59	1.00	30.00	PASS	
	3	0			23.12	-0.31	22.81	1.00	30.00	PASS	
	3	1			23.13	-0.31	22.82	1.00	30.00	PASS	
	3	2			23.11	-0.31	22.80	1.00	30.00	PASS	
	6	0		22.19	-0.31	21.88	1.00	30.00	PASS		
	16QAM	1		0	22.86	-0.31	22.55	1.00	30.00	PASS	
1		2		23.13	-0.31	22.82	1.00	30.00	PASS		
1		5		23.14	-0.31	22.83	1.00	30.00	PASS		
3		0		22.38	-0.31	22.07	1.00	30.00	PASS		
3		1		22.16	-0.31	21.85	1.00	30.00	PASS		
3		2		22.12	-0.31	21.81	1.00	30.00	PASS		
6		0		21.24	-0.31	20.93	1.00	30.00	PASS		



Radiated Power (EIRP) for LTE Band 4 /3M										
BW (MHz)	UL Channel	RB Size	RB offset	Modulation	Conduction AVG Power(dBm)	Ant Gain (dBi)	EIRP (dBm)	EIRP Limit(W)	EIRP Limit(dBm)	Verdict
3	Lowest	1	0	QPSK	23.51	-0.31	23.20	1.00	30.00	PASS
		1	7		23.44	-0.31	23.13	1.00	30.00	PASS
		1	14		23.49	-0.31	23.18	1.00	30.00	PASS
		8	0		22.23	-0.31	21.92	1.00	30.00	PASS
		8	4		22.15	-0.31	21.84	1.00	30.00	PASS
		8	7		22.21	-0.31	21.90	1.00	30.00	PASS
		15	0	22.23	-0.31	21.92	1.00	30.00	PASS	
		1	0	16QAM	22.52	-0.31	22.21	1.00	30.00	PASS
		1	7		22.5	-0.31	22.19	1.00	30.00	PASS
		1	14		22.54	-0.31	22.23	1.00	30.00	PASS
		8	0		21.34	-0.31	21.03	1.00	30.00	PASS
		8	4		21.4	-0.31	21.09	1.00	30.00	PASS
		8	7		21.4	-0.31	21.09	1.00	30.00	PASS
		15	0	21.25	-0.31	20.94	1.00	30.00	PASS	
		Middle	QPSK	1	0	23.21	-0.31	22.90	1.00	30.00
	1			7	23.29	-0.31	22.98	1.00	30.00	PASS
	1			14	23.28	-0.31	22.97	1.00	30.00	PASS
	8			0	22.26	-0.31	21.95	1.00	30.00	PASS
	8			4	22.31	-0.31	22.00	1.00	30.00	PASS
	8			7	22.26	-0.31	21.95	1.00	30.00	PASS
	15		0	22.28	-0.31	21.97	1.00	30.00	PASS	
	16QAM		1	0	23.33	-0.31	23.02	1.00	30.00	PASS
			1	7	23.65	-0.31	23.34	1.00	30.00	PASS
			1	14	23.56	-0.31	23.25	1.00	30.00	PASS
			8	0	21.4	-0.31	21.09	1.00	30.00	PASS
			8	4	21.41	-0.31	21.10	1.00	30.00	PASS
			8	7	21.41	-0.31	21.10	1.00	30.00	PASS
	15		0	21.49	-0.31	21.18	1.00	30.00	PASS	
	Highest		QPSK	1	0	23.23	-0.31	22.92	1.00	30.00
		1		7	23.22	-0.31	22.91	1.00	30.00	PASS
		1		14	23.23	-0.31	22.92	1.00	30.00	PASS
		8		0	22.11	-0.31	21.80	1.00	30.00	PASS
		8		4	22.15	-0.31	21.84	1.00	30.00	PASS
		8		7	22.14	-0.31	21.83	1.00	30.00	PASS
		15	0	22.12	-0.31	21.81	1.00	30.00	PASS	
		16QAM	1	0	23.09	-0.31	22.78	1.00	30.00	PASS
1			7	23.02	-0.31	22.71	1.00	30.00	PASS	
1			14	22.98	-0.31	22.67	1.00	30.00	PASS	
8			0	21.5	-0.31	21.19	1.00	30.00	PASS	
8			4	21.55	-0.31	21.24	1.00	30.00	PASS	
8			7	21.53	-0.31	21.22	1.00	30.00	PASS	
15		0	21.25	-0.31	20.94	1.00	30.00	PASS		



Radiated Power (EIRP) for LTE Band 4 /5M										
BW (MHz)	UL Channel	RB Size	RB offset	Modulation	Conduction AVG Power(dBm)	Ant Gain (dBi)	EIRP (dBm)	EIRP Limit(W)	EIRP Limit(dBm)	Verdict
5	Lowest	1	0	QPSK	22.26	-0.31	21.95	1.00	30.00	PASS
		1	12		22.33	-0.31	22.02	1.00	30.00	PASS
		1	24		22.30	-0.31	21.99	1.00	30.00	PASS
		12	0		22.50	-0.31	22.19	1.00	30.00	PASS
		12	6		22.55	-0.31	22.24	1.00	30.00	PASS
		12	11		22.11	-0.31	21.80	1.00	30.00	PASS
		25	0		23.18	-0.31	22.87	1.00	30.00	PASS
		1	0	16QAM	21.01	-0.31	20.70	1.00	30.00	PASS
		1	12		21.30	-0.31	20.99	1.00	30.00	PASS
		1	24		21.08	-0.31	20.77	1.00	30.00	PASS
		12	0		21.79	-0.31	21.48	1.00	30.00	PASS
		12	6		21.31	-0.31	21.00	1.00	30.00	PASS
		12	11		21.34	-0.31	21.03	1.00	30.00	PASS
		25	0		21.3	-0.31	20.99	1.00	30.00	PASS
		1	0	QPSK	23.13	-0.31	22.82	1.00	30.00	PASS
	1	12	23.17		-0.31	22.86	1.00	30.00	PASS	
	1	24	23.29		-0.31	22.98	1.00	30.00	PASS	
	12	0	22.21		-0.31	21.90	1.00	30.00	PASS	
	12	6	22.27		-0.31	21.96	1.00	30.00	PASS	
	12	11	22.32		-0.31	22.01	1.00	30.00	PASS	
	25	0	22.31		-0.31	22.00	1.00	30.00	PASS	
	1	0	16QAM	22.34	-0.31	22.03	1.00	30.00	PASS	
	1	12		22.37	-0.31	22.06	1.00	30.00	PASS	
	1	24		22.88	-0.31	22.57	1.00	30.00	PASS	
	12	0		21.38	-0.31	21.07	1.00	30.00	PASS	
	12	6		21.4	-0.31	21.09	1.00	30.00	PASS	
	12	11		21.37	-0.31	21.06	1.00	30.00	PASS	
	25	0		21.31	-0.31	21.00	1.00	30.00	PASS	
	1	0	QPSK	23.05	-0.31	22.74	1.00	30.00	PASS	
	1	12		23.03	-0.31	22.72	1.00	30.00	PASS	
	1	24		23.16	-0.31	22.85	1.00	30.00	PASS	
	12	0		22.2	-0.31	21.89	1.00	30.00	PASS	
	12	6		22.14	-0.31	21.83	1.00	30.00	PASS	
	12	11		22.13	-0.31	21.82	1.00	30.00	PASS	
	25	0		22.19	-0.31	21.88	1.00	30.00	PASS	
	1	0	16QAM	22.59	-0.31	22.28	1.00	30.00	PASS	
	1	12		22.66	-0.31	22.35	1.00	30.00	PASS	
	1	24		22.88	-0.31	22.57	1.00	30.00	PASS	
	12	0		21.06	-0.31	20.75	1.00	30.00	PASS	
	12	6		21.12	-0.31	20.81	1.00	30.00	PASS	
	12	11		21.17	-0.31	20.86	1.00	30.00	PASS	
	25	0		21.32	-0.31	21.01	1.00	30.00	PASS	



Radiated Power (EIRP) for LTE Band 4 /10M										
BW (MHz)	UL Channel	RB Size	RB offset	Modulation	Conduction AVG Power(dBm)	Ant Gain (dBi)	EIRP (dBm)	EIRP Limit(W)	EIRP Limit(dBm)	Verdict
10	Lowest	1	0	QPSK	23.38	-0.31	23.07	1.00	30.00	PASS
		1	24		23.43	-0.31	23.12	1.00	30.00	PASS
		1	49		23.42	-0.31	23.11	1.00	30.00	PASS
		25	0		22.23	-0.31	21.92	1.00	30.00	PASS
		25	12		22.28	-0.31	21.97	1.00	30.00	PASS
		25	24		22.29	-0.31	21.98	1.00	30.00	PASS
		50	0	22.25	-0.31	21.94	1.00	30.00	PASS	
		1	0	16QAM	22.92	-0.31	22.61	1.00	30.00	PASS
		1	24		22.88	-0.31	22.57	1.00	30.00	PASS
		1	49		22.88	-0.31	22.57	1.00	30.00	PASS
		25	0		21.4	-0.31	21.09	1.00	30.00	PASS
		25	12		21.37	-0.31	21.06	1.00	30.00	PASS
		25	24		21.36	-0.31	21.05	1.00	30.00	PASS
		50	0	21.39	-0.31	21.08	1.00	30.00	PASS	
		1	0	QPSK	23.53	-0.31	23.22	1.00	30.00	PASS
	1	24	23.5		-0.31	23.19	1.00	30.00	PASS	
	1	49	23.46		-0.31	23.15	1.00	30.00	PASS	
	25	0	22.21		-0.31	21.90	1.00	30.00	PASS	
	25	12	22.28		-0.31	21.97	1.00	30.00	PASS	
	25	24	22.3		-0.31	21.99	1.00	30.00	PASS	
	50	0	22.36	-0.31	22.05	1.00	30.00	PASS		
	1	0	16QAM	22.54	-0.31	22.23	1.00	30.00	PASS	
	1	24		22.54	-0.31	22.23	1.00	30.00	PASS	
	1	49		22.6	-0.31	22.29	1.00	30.00	PASS	
	25	0		21.35	-0.31	21.04	1.00	30.00	PASS	
	25	12		21.39	-0.31	21.08	1.00	30.00	PASS	
	25	24		21.44	-0.31	21.13	1.00	30.00	PASS	
	50	0	21.37	-0.31	21.06	1.00	30.00	PASS		
	1	0	QPSK	22.95	-0.31	22.64	1.00	30.00	PASS	
	1	24		23.07	-0.31	22.76	1.00	30.00	PASS	
	1	49		22.95	-0.31	22.64	1.00	30.00	PASS	
	25	0		22.13	-0.31	21.82	1.00	30.00	PASS	
	25	12		22.26	-0.31	21.95	1.00	30.00	PASS	
	25	24		22.12	-0.31	21.81	1.00	30.00	PASS	
	50	0	22.29	-0.31	21.98	1.00	30.00	PASS		
	1	0	16QAM	23.27	-0.31	22.96	1.00	30.00	PASS	
	1	24		23.33	-0.31	23.02	1.00	30.00	PASS	
	1	49		23.36	-0.31	23.05	1.00	30.00	PASS	
	25	0		21.29	-0.31	20.98	1.00	30.00	PASS	
	25	12		21.4	-0.31	21.09	1.00	30.00	PASS	
	25	24		21.27	-0.31	20.96	1.00	30.00	PASS	
	50	0	21.39	-0.31	21.08	1.00	30.00	PASS		



Radiated Power (EIRP) for LTE Band 4 /15M										
BW (MHz)	UL Channel	RB Size	RB offset	Modulation	Conduction AVG Power(dBm)	Ant Gain (dBi)	EIRP (dBm)	EIRP Limit(W)	EIRP Limit(dBm)	Verdict
15	Lowest	1	0	QPSK	23.42	-0.31	23.11	1.00	30.00	PASS
		1	37		23.48	-0.31	23.17	1.00	30.00	PASS
		1	74		23.4	-0.31	23.09	1.00	30.00	PASS
		36	0		22.25	-0.31	21.94	1.00	30.00	PASS
		36	18		22.25	-0.31	21.94	1.00	30.00	PASS
		36	39		22.21	-0.31	21.90	1.00	30.00	PASS
		75	0		22.3	-0.31	21.99	1.00	30.00	PASS
		1	0	16QAM	22.52	-0.31	22.21	1.00	30.00	PASS
		1	37		22.5	-0.31	22.19	1.00	30.00	PASS
		1	74		22.57	-0.31	22.26	1.00	30.00	PASS
		36	0		21.31	-0.31	21.00	1.00	30.00	PASS
		36	18		21.3	-0.31	20.99	1.00	30.00	PASS
		36	39		21.33	-0.31	21.02	1.00	30.00	PASS
		75	0		21.35	-0.31	21.04	1.00	30.00	PASS
	Middle	QPSK	1	0	23.22	-0.31	22.91	1.00	30.00	PASS
			1	37	23.19	-0.31	22.88	1.00	30.00	PASS
			1	74	23.22	-0.31	22.91	1.00	30.00	PASS
			36	0	22.27	-0.31	21.96	1.00	30.00	PASS
			36	18	22.24	-0.31	21.93	1.00	30.00	PASS
			36	39	22.33	-0.31	22.02	1.00	30.00	PASS
			75	0	22.32	-0.31	22.01	1.00	30.00	PASS
		16QAM	1	0	23.55	-0.31	23.24	1.00	30.00	PASS
			1	37	23.54	-0.31	23.23	1.00	30.00	PASS
			1	74	23.39	-0.31	23.08	1.00	30.00	PASS
			36	0	21.4	-0.31	21.09	1.00	30.00	PASS
			36	18	21.43	-0.31	21.12	1.00	30.00	PASS
			36	39	21.38	-0.31	21.07	1.00	30.00	PASS
			75	0	21.37	-0.31	21.06	1.00	30.00	PASS
	Highest	QPSK	1	0	23.21	-0.31	22.90	1.00	30.00	PASS
			1	37	23.21	-0.31	22.90	1.00	30.00	PASS
			1	74	23.2	-0.31	22.89	1.00	30.00	PASS
			36	0	22.2	-0.31	21.89	1.00	30.00	PASS
			36	18	22.18	-0.31	21.87	1.00	30.00	PASS
			36	39	22.2	-0.31	21.89	1.00	30.00	PASS
			75	0	22.16	-0.31	21.85	1.00	30.00	PASS
		16QAM	1	0	22.84	-0.31	22.53	1.00	30.00	PASS
			1	37	22.87	-0.31	22.56	1.00	30.00	PASS
			1	74	23.03	-0.31	22.72	1.00	30.00	PASS
			36	0	21.29	-0.31	20.98	1.00	30.00	PASS
			36	18	21.22	-0.31	20.91	1.00	30.00	PASS
			36	39	21.27	-0.31	20.96	1.00	30.00	PASS
			75	0	21.32	-0.31	21.01	1.00	30.00	PASS



Radiated Power (EIRP) for LTE Band 4 /20M										
BW (MHz)	UL Channel	RB Size	RB offset	Modulation	Conduction AVG Power(dBm)	Ant Gain (dBi)	EIRP (dBm)	EIRP Limit(W)	EIRP Limit(dBm)	Verdict
20	Lowest	1	0	QPSK	23.3	-0.31	22.99	1.00	30.00	PASS
		1	49		23.35	-0.31	23.04	1.00	30.00	PASS
		1	99		23.41	-0.31	23.10	1.00	30.00	PASS
		50	0		22.25	-0.31	21.94	1.00	30.00	PASS
		50	24		22.27	-0.31	21.96	1.00	30.00	PASS
		50	49		22.33	-0.31	22.02	1.00	30.00	PASS
		100	0	22.22	-0.31	21.91	1.00	30.00	PASS	
		1	0	22.97	-0.31	22.66	1.00	30.00	PASS	
		1	49	23	-0.31	22.69	1.00	30.00	PASS	
		1	99	23.1	-0.31	22.79	1.00	30.00	PASS	
		50	0	23.71	-0.31	23.40	1.00	30.00	PASS	
		50	24	21.38	-0.31	21.07	1.00	30.00	PASS	
		50	49	21.46	-0.31	21.15	1.00	30.00	PASS	
		100	0	21.35	-0.31	21.04	1.00	30.00	PASS	
		1	0	23.32	-0.31	23.01	1.00	30.00	PASS	
	1	49	23.44	-0.31	23.13	1.00	30.00	PASS		
	1	99	23.42	-0.31	23.11	1.00	30.00	PASS		
	50	0	22.24	-0.31	21.93	1.00	30.00	PASS		
	50	24	22.27	-0.31	21.96	1.00	30.00	PASS		
	50	49	22.26	-0.31	21.95	1.00	30.00	PASS		
	100	0	22.24	-0.31	21.93	1.00	30.00	PASS		
	1	0	23.33	-0.31	23.02	1.00	30.00	PASS		
	1	49	23.42	-0.31	23.11	1.00	30.00	PASS		
	1	99	23.27	-0.31	22.96	1.00	30.00	PASS		
	50	0	21.41	-0.31	21.10	1.00	30.00	PASS		
	50	24	21.42	-0.31	21.11	1.00	30.00	PASS		
	50	49	21.39	-0.31	21.08	1.00	30.00	PASS		
	100	0	21.34	-0.31	21.03	1.00	30.00	PASS		
	1	0	23.25	-0.31	22.94	1.00	30.00	PASS		
	1	49	23.28	-0.31	22.97	1.00	30.00	PASS		
	1	99	23.33	-0.31	23.02	1.00	30.00	PASS		
	50	0	22.26	-0.31	21.95	1.00	30.00	PASS		
	50	24	22.18	-0.31	21.87	1.00	30.00	PASS		
	50	49	22.32	-0.31	22.01	1.00	30.00	PASS		
	100	0	22.21	-0.31	21.90	1.00	30.00	PASS		
	1	0	22.84	-0.31	22.53	1.00	30.00	PASS		
	1	49	22.72	-0.31	22.41	1.00	30.00	PASS		
	1	99	22.54	-0.31	22.23	1.00	30.00	PASS		
	50	0	21.36	-0.31	21.05	1.00	30.00	PASS		
	50	24	21.36	-0.31	21.05	1.00	30.00	PASS		
	50	49	21.45	-0.31	21.14	1.00	30.00	PASS		
	100	0	21.38	-0.31	21.07	1.00	30.00	PASS		



Radiated Power (ERP) for LTE Band 5 /1.4M										
BW (MHz)	UL Channel	RB Size	RB offset	Modulation	Conduction AVG Power(dBm)	Ant Gain (dBi)	ERP (dBm)	ERP Limit(W)	ERP Limit(dBm)	Verdict
1.4	Lowest	1	0	QPSK	24.12	-0.42	21.55	7.00	38.45	PASS
		1	2		24.06	-0.42	21.49	7.00	38.45	PASS
		1	5		24.07	-0.42	21.50	7.00	38.45	PASS
		3	0		23.88	-0.42	21.31	7.00	38.45	PASS
		3	1		23.82	-0.42	21.25	7.00	38.45	PASS
		3	2		23.82	-0.42	21.25	7.00	38.45	PASS
		6	0	22.87	-0.42	20.30	7.00	38.45	PASS	
		1	0	16QAM	23.60	-0.42	21.03	7.00	38.45	PASS
		1	2		23.57	-0.42	21.00	7.00	38.45	PASS
		1	5		23.59	-0.42	21.02	7.00	38.45	PASS
		3	0		22.88	-0.42	20.31	7.00	38.45	PASS
		3	1		22.86	-0.42	20.29	7.00	38.45	PASS
		3	2		22.95	-0.42	20.38	7.00	38.45	PASS
		6	0	21.78	-0.42	19.21	7.00	38.45	PASS	
		1	0	QPSK	24.04	-0.42	21.47	7.00	38.45	PASS
	1	2	24.16		-0.42	21.59	7.00	38.45	PASS	
	1	5	24.16		-0.42	21.59	7.00	38.45	PASS	
	3	0	23.86		-0.42	21.29	7.00	38.45	PASS	
	3	1	23.90		-0.42	21.33	7.00	38.45	PASS	
	3	2	23.85		-0.42	21.28	7.00	38.45	PASS	
	6	0	22.87	-0.42	20.30	7.00	38.45	PASS		
	1	0	16QAM	23.97	-0.42	21.40	7.00	38.45	PASS	
	1	2		23.72	-0.42	21.15	7.00	38.45	PASS	
	1	5		23.67	-0.42	21.10	7.00	38.45	PASS	
	3	0		22.97	-0.42	20.40	7.00	38.45	PASS	
	3	1		22.82	-0.42	20.25	7.00	38.45	PASS	
	3	2		22.85	-0.42	20.28	7.00	38.45	PASS	
	6	0	21.85	-0.42	19.28	7.00	38.45	PASS		
	1	0	QPSK	23.61	-0.42	21.04	7.00	38.45	PASS	
	1	2		23.74	-0.42	21.17	7.00	38.45	PASS	
	1	5		23.73	-0.42	21.16	7.00	38.45	PASS	
	3	0		23.80	-0.42	21.23	7.00	38.45	PASS	
	3	1		23.83	-0.42	21.26	7.00	38.45	PASS	
	3	2		23.87	-0.42	21.30	7.00	38.45	PASS	
	6	0	22.88	-0.42	20.31	7.00	38.45	PASS		
	1	0	16QAM	23.77	-0.42	21.20	7.00	38.45	PASS	
	1	2		23.83	-0.42	21.26	7.00	38.45	PASS	
	1	5		24.01	-0.42	21.44	7.00	38.45	PASS	
	3	0		22.77	-0.42	20.20	7.00	38.45	PASS	
	3	1		22.90	-0.42	20.33	7.00	38.45	PASS	
	3	2		22.93	-0.42	20.36	7.00	38.45	PASS	
	6	0	21.90	-0.42	19.33	7.00	38.45	PASS		



Radiated Power (ERP) for LTE Band 5 /3M											
BW (MHz)	UL Channel	RB Size	RB offset	Modulation	Conduction AVG Power(dBm)	Ant Gain (dBi)	ERP (dBm)	ERP Limit(W)	ERP Limit(dBm)	Verdict	
3	Lowest	1	0	QPSK	24.15	-0.42	21.58	7.00	38.45	PASS	
		1	7		24.04	-0.42	21.47	7.00	38.45	PASS	
		1	14		24.09	-0.42	21.52	7.00	38.45	PASS	
		8	0		22.80	-0.42	20.23	7.00	38.45	PASS	
		8	4		22.81	-0.42	20.24	7.00	38.45	PASS	
		8	7		22.68	-0.42	20.11	7.00	38.45	PASS	
		15	0	22.72	-0.42	20.15	7.00	38.45	PASS		
		1	0	23.60	-0.42	21.03	7.00	38.45	PASS		
		1	7	23.62	-0.42	21.05	7.00	38.45	PASS		
		1	14	23.58	-0.42	21.01	7.00	38.45	PASS		
		8	0	21.62	-0.42	19.05	7.00	38.45	PASS		
		8	4	21.68	-0.42	19.11	7.00	38.45	PASS		
		8	7	21.71	-0.42	19.14	7.00	38.45	PASS		
		15	0	21.71	-0.42	19.14	7.00	38.45	PASS		
		Middle	QPSK	1	0	24.04	-0.42	21.47	7.00	38.45	PASS
	1			7	24.12	-0.42	21.55	7.00	38.45	PASS	
	1			14	24.16	-0.42	21.59	7.00	38.45	PASS	
	8			0	22.80	-0.42	20.23	7.00	38.45	PASS	
	8			4	22.93	-0.42	20.36	7.00	38.45	PASS	
	8			7	22.88	-0.42	20.31	7.00	38.45	PASS	
	15		0	22.90	-0.42	20.33	7.00	38.45	PASS		
	16QAM		1	0	23.09	-0.42	20.52	7.00	38.45	PASS	
			1	7	23.24	-0.42	20.67	7.00	38.45	PASS	
			1	14	23.17	-0.42	20.60	7.00	38.45	PASS	
			8	0	21.83	-0.42	19.26	7.00	38.45	PASS	
			8	4	22.12	-0.42	19.55	7.00	38.45	PASS	
			8	7	21.92	-0.42	19.35	7.00	38.45	PASS	
			15	0	22.01	-0.42	19.44	7.00	38.45	PASS	
			Highest	QPSK	1	0	23.74	-0.42	21.17	7.00	38.45
		1			7	23.72	-0.42	21.15	7.00	38.45	PASS
	1	14			23.77	-0.42	21.20	7.00	38.45	PASS	
	8	0			22.87	-0.42	20.30	7.00	38.45	PASS	
	8	4			22.92	-0.42	20.35	7.00	38.45	PASS	
	8	7			22.86	-0.42	20.29	7.00	38.45	PASS	
	15	0		22.80	-0.42	20.23	7.00	38.45	PASS		
	16QAM	1		0	23.86	-0.42	21.29	7.00	38.45	PASS	
1		7		23.86	-0.42	21.29	7.00	38.45	PASS		
1		14		23.88	-0.42	21.31	7.00	38.45	PASS		
8		0		21.84	-0.42	19.27	7.00	38.45	PASS		
8		4		21.82	-0.42	19.25	7.00	38.45	PASS		
8		7		21.87	-0.42	19.30	7.00	38.45	PASS		
15		0		21.85	-0.42	19.28	7.00	38.45	PASS		



Radiated Power (ERP) for LTE Band 5 /5M										
BW (MHz)	UL Channel	RB Size	RB offset	Modulation	Conduction AVG Power(dBm)	Ant Gain (dBi)	ERP (dBm)	ERP Limit(W)	ERP Limit(dBm)	Verdict
5	Lowest	1	0	QPSK	23.72	-0.42	21.15	7.00	38.45	PASS
		1	12		23.68	-0.42	21.11	7.00	38.45	PASS
		1	24		23.73	-0.42	21.16	7.00	38.45	PASS
		12	0		22.79	-0.42	20.22	7.00	38.45	PASS
		12	6		22.78	-0.42	20.21	7.00	38.45	PASS
		12	11		22.81	-0.42	20.24	7.00	38.45	PASS
		25	0		22.73	-0.42	20.16	7.00	38.45	PASS
		1	0	16QAM	23.22	-0.42	20.65	7.00	38.45	PASS
		1	12		23.23	-0.42	20.66	7.00	38.45	PASS
		1	24		23.15	-0.42	20.58	7.00	38.45	PASS
		12	0		21.70	-0.42	19.13	7.00	38.45	PASS
		12	6		21.74	-0.42	19.17	7.00	38.45	PASS
		12	11		21.72	-0.42	19.15	7.00	38.45	PASS
		25	0		21.91	-0.42	19.34	7.00	38.45	PASS
		1	0	QPSK	23.98	-0.42	21.41	7.00	38.45	PASS
	1	12	24.02		-0.42	21.45	7.00	38.45	PASS	
	1	24	24.08		-0.42	21.51	7.00	38.45	PASS	
	12	0	22.83		-0.42	20.26	7.00	38.45	PASS	
	12	6	22.98		-0.42	20.41	7.00	38.45	PASS	
	12	11	22.93		-0.42	20.36	7.00	38.45	PASS	
	25	0	22.96		-0.42	20.39	7.00	38.45	PASS	
	1	0	16QAM	23.46	-0.42	20.89	7.00	38.45	PASS	
	1	12		23.53	-0.42	20.96	7.00	38.45	PASS	
	1	24		23.51	-0.42	20.94	7.00	38.45	PASS	
	12	0		21.71	-0.42	19.14	7.00	38.45	PASS	
	12	6		21.93	-0.42	19.36	7.00	38.45	PASS	
	12	11		21.94	-0.42	19.37	7.00	38.45	PASS	
	25	0		21.92	-0.42	19.35	7.00	38.45	PASS	
	1	0	QPSK	23.90	-0.42	21.33	7.00	38.45	PASS	
	1	12		23.78	-0.42	21.21	7.00	38.45	PASS	
	1	24		23.94	-0.42	21.37	7.00	38.45	PASS	
	12	0		22.92	-0.42	20.35	7.00	38.45	PASS	
	12	6		22.76	-0.42	20.19	7.00	38.45	PASS	
	12	11		22.88	-0.42	20.31	7.00	38.45	PASS	
	25	0		22.86	-0.42	20.29	7.00	38.45	PASS	
	1	0	16QAM	23.08	-0.42	20.51	7.00	38.45	PASS	
1	12	23.12		-0.42	20.55	7.00	38.45	PASS		
1	24	23.39		-0.42	20.82	7.00	38.45	PASS		
12	0	21.97		-0.42	19.40	7.00	38.45	PASS		
12	6	21.91		-0.42	19.34	7.00	38.45	PASS		
12	11	21.93		-0.42	19.36	7.00	38.45	PASS		
25	0	21.73		-0.42	19.16	7.00	38.45	PASS		



Radiated Power (ERP) for LTE Band 5 /10M											
BW (MHz)	UL Channel	RB Size	RB offset	Modulation	Conduction AVG Power(dBm)	Ant Gain (dBi)	ERP (dBm)	ERP Limit(W)	ERP Limit(dBm)	Verdict	
10	Lowest	1	0	QPSK	24.05	-0.42	21.48	7.00	38.45	PASS	
		1	24		24.07	-0.42	21.50	7.00	38.45	PASS	
		1	49		24.02	-0.42	21.45	7.00	38.45	PASS	
		25	0		22.86	-0.42	20.29	7.00	38.45	PASS	
		25	12		22.75	-0.42	20.18	7.00	38.45	PASS	
		25	24		22.83	-0.42	20.26	7.00	38.45	PASS	
		50	0	22.73	-0.42	20.16	7.00	38.45	PASS		
		1	0	16QAM	23.07	-0.42	20.50	7.00	38.45	PASS	
		1	24		23.07	-0.42	20.50	7.00	38.45	PASS	
		1	49		23.06	-0.42	20.49	7.00	38.45	PASS	
		25	0		21.89	-0.42	19.32	7.00	38.45	PASS	
		25	12		21.83	-0.42	19.26	7.00	38.45	PASS	
		25	24		21.87	-0.42	19.30	7.00	38.45	PASS	
		50	0	21.87	-0.42	19.30	7.00	38.45	PASS		
		Middle	QPSK	1	0	23.82	-0.42	21.25	7.00	38.45	PASS
	1			24	23.87	-0.42	21.30	7.00	38.45	PASS	
	1			49	23.91	-0.42	21.34	7.00	38.45	PASS	
	25			0	22.78	-0.42	20.21	7.00	38.45	PASS	
	25			12	23.02	-0.42	20.45	7.00	38.45	PASS	
	25			24	22.97	-0.42	20.40	7.00	38.45	PASS	
	50		0	22.97	-0.42	20.40	7.00	38.45	PASS		
	16QAM		1	0	23.69	-0.42	21.12	7.00	38.45	PASS	
			1	24	23.87	-0.42	21.30	7.00	38.45	PASS	
			1	49	23.94	-0.42	21.37	7.00	38.45	PASS	
			25	0	24.20	-0.42	21.63	7.00	38.45	PASS	
			25	12	22.00	-0.42	19.43	7.00	38.45	PASS	
			25	24	21.98	-0.42	19.41	7.00	38.45	PASS	
			50	0	22.00	-0.42	19.43	7.00	38.45	PASS	
			Highest	QPSK	1	0	24.01	-0.42	21.44	7.00	38.45
		1			24	24.03	-0.42	21.46	7.00	38.45	PASS
	1	49			24.11	-0.42	21.54	7.00	38.45	PASS	
	25	0			22.97	-0.42	20.40	7.00	38.45	PASS	
	25	12			22.87	-0.42	20.30	7.00	38.45	PASS	
	25	24			22.91	-0.42	20.34	7.00	38.45	PASS	
	50	0		22.94	-0.42	20.37	7.00	38.45	PASS		
	16QAM	1		0	23.49	-0.42	20.92	7.00	38.45	PASS	
1		24		23.41	-0.42	20.84	7.00	38.45	PASS		
1		49		23.60	-0.42	21.03	7.00	38.45	PASS		
25		0		21.91	-0.42	19.34	7.00	38.45	PASS		
25		12		21.90	-0.42	19.33	7.00	38.45	PASS		
25		24		21.94	-0.42	19.37	7.00	38.45	PASS		
50		0		21.96	-0.42	19.39	7.00	38.45	PASS		



Radiated Power (ERP) for LTE Band 12 /1.4M										
BW (MHz)	UL Channel	RB Size	RB offset	Modulation	Conduction AVG Power(dBm)	Ant Gain (dBi)	ERP (dBm)	ERP Limit(W)	ERP Limit(dBm)	Verdict
1.4	Lowest	1	0	QPSK	24.21	-0.46	21.60	3.00	34.77	PASS
		1	2		24.20	-0.46	21.59	3.00	34.77	PASS
		1	5		24.25	-0.46	21.64	3.00	34.77	PASS
		3	0		23.99	-0.46	21.38	3.00	34.77	PASS
		3	1		24.01	-0.46	21.40	3.00	34.77	PASS
		3	2		24.06	-0.46	21.45	3.00	34.77	PASS
		6	0	22.90	-0.46	20.29	3.00	34.77	PASS	
		1	0	16QAM	23.60	-0.46	20.99	3.00	34.77	PASS
		1	2		23.62	-0.46	21.01	3.00	34.77	PASS
		1	5		23.66	-0.46	21.05	3.00	34.77	PASS
		3	0		22.87	-0.46	20.26	3.00	34.77	PASS
		3	1		22.93	-0.46	20.32	3.00	34.77	PASS
		3	2		22.88	-0.46	20.27	3.00	34.77	PASS
		6	0	21.96	-0.46	19.35	3.00	34.77	PASS	
	Middle	QPSK	1	0	23.87	-0.46	21.26	3.00	34.77	PASS
			1	2	23.97	-0.46	21.36	3.00	34.77	PASS
			1	5	23.90	-0.46	21.29	3.00	34.77	PASS
			3	0	23.93	-0.46	21.32	3.00	34.77	PASS
			3	1	24.04	-0.46	21.43	3.00	34.77	PASS
			3	2	23.99	-0.46	21.38	3.00	34.77	PASS
		6	0	22.98	-0.46	20.37	3.00	34.77	PASS	
		16QAM	1	0	23.54	-0.46	20.93	3.00	34.77	PASS
			1	2	23.60	-0.46	20.99	3.00	34.77	PASS
			1	5	23.39	-0.46	20.78	3.00	34.77	PASS
			3	0	22.98	-0.46	20.37	3.00	34.77	PASS
			3	1	22.92	-0.46	20.31	3.00	34.77	PASS
			3	2	22.92	-0.46	20.31	3.00	34.77	PASS
			6	0	22.14	-0.46	19.53	3.00	34.77	PASS
	Highest		QPSK	1	0	24.26	-0.46	21.65	3.00	34.77
		1		2	24.09	-0.46	21.48	3.00	34.77	PASS
		1		5	24.12	-0.46	21.51	3.00	34.77	PASS
		3		0	24.12	-0.46	21.51	3.00	34.77	PASS
		3		1	24.01	-0.46	21.40	3.00	34.77	PASS
		3		2	24.02	-0.46	21.41	3.00	34.77	PASS
		6	0	23.09	-0.46	20.48	3.00	34.77	PASS	
		16QAM	1	0	23.21	-0.46	20.60	3.00	34.77	PASS
1			2	23.24	-0.46	20.63	3.00	34.77	PASS	
1			5	23.17	-0.46	20.56	3.00	34.77	PASS	
3			0	23.00	-0.46	20.39	3.00	34.77	PASS	
3			1	22.97	-0.46	20.36	3.00	34.77	PASS	
3			2	23.03	-0.46	20.42	3.00	34.77	PASS	
6			0	22.20	-0.46	19.59	3.00	34.77	PASS	



Radiated Power (ERP) for LTE Band 12 /3M											
BW (MHz)	UL Channel	RB Size	RB offset	Modulation	Conduction AVG Power(dBm)	Ant Gain (dBi)	ERP (dBm)	ERP Limit(W)	ERP Limit(dBm)	Verdict	
3	Lowest	1	0	QPSK	24.16	-0.46	21.55	3.00	34.77	PASS	
		1	7		24.18	-0.46	21.57	3.00	34.77	PASS	
		1	14		24.07	-0.46	21.46	3.00	34.77	PASS	
		8	0		22.90	-0.46	20.29	3.00	34.77	PASS	
		8	4		22.97	-0.46	20.36	3.00	34.77	PASS	
		8	7		22.93	-0.46	20.32	3.00	34.77	PASS	
		15	0	22.87	-0.46	20.26	3.00	34.77	PASS		
		1	0	22.71	-0.46	20.10	3.00	34.77	PASS		
		1	7	22.64	-0.46	20.03	3.00	34.77	PASS		
		1	14	22.66	-0.46	20.05	3.00	34.77	PASS		
		8	0	21.96	-0.46	19.35	3.00	34.77	PASS		
		8	4	22.03	-0.46	19.42	3.00	34.77	PASS		
		8	7	22.50	-0.46	19.89	3.00	34.77	PASS		
		15	0	21.89	-0.46	19.28	3.00	34.77	PASS		
		Middle	QPSK	1	0	23.92	-0.46	21.31	3.00	34.77	PASS
	1			7	23.86	-0.46	21.25	3.00	34.77	PASS	
	1			14	23.89	-0.46	21.28	3.00	34.77	PASS	
	8			0	23.04	-0.46	20.43	3.00	34.77	PASS	
	8			4	22.98	-0.46	20.37	3.00	34.77	PASS	
	8			7	22.90	-0.46	20.29	3.00	34.77	PASS	
	15		0	22.97	-0.46	20.36	3.00	34.77	PASS		
	16QAM		1	0	23.46	-0.46	20.85	3.00	34.77	PASS	
			1	7	23.49	-0.46	20.88	3.00	34.77	PASS	
			1	14	23.61	-0.46	21.00	3.00	34.77	PASS	
			8	0	22.40	-0.46	19.79	3.00	34.77	PASS	
			8	4	21.89	-0.46	19.28	3.00	34.77	PASS	
			8	7	21.92	-0.46	19.31	3.00	34.77	PASS	
			15	0	21.95	-0.46	19.34	3.00	34.77	PASS	
			Highest	QPSK	1	0	24.27	-0.46	21.66	3.00	34.77
		1			7	24.29	-0.46	21.68	3.00	34.77	PASS
	1	14			24.11	-0.46	21.50	3.00	34.77	PASS	
	8	0			22.81	-0.46	20.20	3.00	34.77	PASS	
	8	4			22.89	-0.46	20.28	3.00	34.77	PASS	
	8	7			23.02	-0.46	20.41	3.00	34.77	PASS	
	15	0		22.93	-0.46	20.32	3.00	34.77	PASS		
	16QAM	1		0	23.21	-0.46	20.60	3.00	34.77	PASS	
1		7		23.17	-0.46	20.56	3.00	34.77	PASS		
1		14		23.26	-0.46	20.65	3.00	34.77	PASS		
8		0		21.72	-0.46	19.11	3.00	34.77	PASS		
8		4		21.81	-0.46	19.20	3.00	34.77	PASS		
8		7		22.10	-0.46	19.49	3.00	34.77	PASS		
15		0		21.94	-0.46	19.33	3.00	34.77	PASS		



Radiated Power (ERP) for LTE Band 12 /5M										
BW (MHz)	UL Channel	RB Size	RB offset	Modulation	Conduction AVG Power(dBm)	Ant Gain (dBi)	ERP (dBm)	ERP Limit(W)	ERP Limit(dBm)	Verdict
5	Lowest	1	0	QPSK	23.90	-0.46	21.29	3.00	34.77	PASS
		1	12		23.88	-0.46	21.27	3.00	34.77	PASS
		1	24		23.82	-0.46	21.21	3.00	34.77	PASS
		12	0		23.03	-0.46	20.42	3.00	34.77	PASS
		12	6		22.90	-0.46	20.29	3.00	34.77	PASS
		12	11		22.98	-0.46	20.37	3.00	34.77	PASS
		25	0		22.94	-0.46	20.33	3.00	34.77	PASS
		1	0	16QAM	23.26	-0.46	20.65	3.00	34.77	PASS
		1	12		23.27	-0.46	20.66	3.00	34.77	PASS
		1	24		23.22	-0.46	20.61	3.00	34.77	PASS
		12	0		21.80	-0.46	19.19	3.00	34.77	PASS
		12	6		22.31	-0.46	19.70	3.00	34.77	PASS
		12	11		22.32	-0.46	19.71	3.00	34.77	PASS
		25	0		22.51	-0.46	19.90	3.00	34.77	PASS
	Middle	QPSK	1	0	24.09	-0.46	21.48	3.00	34.77	PASS
			1	12	24.02	-0.46	21.41	3.00	34.77	PASS
			1	24	24.02	-0.46	21.41	3.00	34.77	PASS
			12	0	23.01	-0.46	20.40	3.00	34.77	PASS
			12	6	22.97	-0.46	20.36	3.00	34.77	PASS
			12	11	22.98	-0.46	20.37	3.00	34.77	PASS
			25	0	22.92	-0.46	20.31	3.00	34.77	PASS
		16QAM	1	0	23.10	-0.46	20.49	3.00	34.77	PASS
			1	12	23.08	-0.46	20.47	3.00	34.77	PASS
			1	24	22.92	-0.46	20.31	3.00	34.77	PASS
			12	0	22.35	-0.46	19.74	3.00	34.77	PASS
			12	6	22.03	-0.46	19.42	3.00	34.77	PASS
			12	11	21.96	-0.46	19.35	3.00	34.77	PASS
			25	0	21.95	-0.46	19.34	3.00	34.77	PASS
	Highest	QPSK	1	0	23.90	-0.46	21.29	3.00	34.77	PASS
			1	12	23.90	-0.46	21.29	3.00	34.77	PASS
			1	24	23.89	-0.46	21.28	3.00	34.77	PASS
			12	0	23.04	-0.46	20.43	3.00	34.77	PASS
			12	6	23.02	-0.46	20.41	3.00	34.77	PASS
			12	11	22.88	-0.46	20.27	3.00	34.77	PASS
			25	0	22.95	-0.46	20.34	3.00	34.77	PASS
		16QAM	1	0	22.51	-0.46	19.90	3.00	34.77	PASS
1			12	22.95	-0.46	20.34	3.00	34.77	PASS	
1			24	22.96	-0.46	20.35	3.00	34.77	PASS	
12			0	21.95	-0.46	19.34	3.00	34.77	PASS	
12			6	21.84	-0.46	19.23	3.00	34.77	PASS	
12			11	21.84	-0.46	19.23	3.00	34.77	PASS	
25			0	21.95	-0.46	19.34	3.00	34.77	PASS	



Radiated Power (ERP) for LTE Band 12 /10M											
BW (MHz)	UL Channel	RB Size	RB offset	Modulation	Conduction AVG Power(dBm)	Ant Gain (dBi)	ERP (dBm)	ERP Limit(W)	ERP Limit(dBm)	Verdict	
10	Lowest	1	0	QPSK	24.20	-0.46	21.59	3.00	34.77	PASS	
		1	24		24.18	-0.46	21.57	3.00	34.77	PASS	
		1	49		24.30	-0.46	21.69	3.00	34.77	PASS	
		25	0		22.84	-0.46	20.23	3.00	34.77	PASS	
		25	12		22.87	-0.46	20.26	3.00	34.77	PASS	
		25	24		22.91	-0.46	20.30	3.00	34.77	PASS	
		50	0	23.05	-0.46	20.44	3.00	34.77	PASS		
		1	0	16QAM	22.73	-0.46	20.12	3.00	34.77	PASS	
		1	24		22.61	-0.46	20.00	3.00	34.77	PASS	
		1	49		22.77	-0.46	20.16	3.00	34.77	PASS	
		25	0		22.47	-0.46	19.86	3.00	34.77	PASS	
		25	12		22.43	-0.46	19.82	3.00	34.77	PASS	
		25	24		22.43	-0.46	19.82	3.00	34.77	PASS	
		50	0	22.44	-0.46	19.83	3.00	34.77	PASS		
		Middle	QPSK	1	0	23.74	-0.46	21.13	3.00	34.77	PASS
	1			24	23.82	-0.46	21.21	3.00	34.77	PASS	
	1			49	23.91	-0.46	21.30	3.00	34.77	PASS	
	25			0	23.01	-0.46	20.40	3.00	34.77	PASS	
	25			12	22.99	-0.46	20.38	3.00	34.77	PASS	
	25			24	22.91	-0.46	20.30	3.00	34.77	PASS	
	50		0	22.94	-0.46	20.33	3.00	34.77	PASS		
	16QAM		1	0	23.41	-0.46	20.80	3.00	34.77	PASS	
			1	24	23.58	-0.46	20.97	3.00	34.77	PASS	
			1	49	23.57	-0.46	20.96	3.00	34.77	PASS	
			25	0	22.44	-0.46	19.83	3.00	34.77	PASS	
			25	12	21.98	-0.46	19.37	3.00	34.77	PASS	
			25	24	22.47	-0.46	19.86	3.00	34.77	PASS	
			50	0	22.08	-0.46	19.47	3.00	34.77	PASS	
			Highest	QPSK	1	0	24.13	-0.46	21.52	3.00	34.77
		1			24	23.97	-0.46	21.36	3.00	34.77	PASS
	1	49			24.12	-0.46	21.51	3.00	34.77	PASS	
	25	0			22.95	-0.46	20.34	3.00	34.77	PASS	
	25	12			22.85	-0.46	20.24	3.00	34.77	PASS	
	25	24			22.91	-0.46	20.30	3.00	34.77	PASS	
	50	0		22.80	-0.46	20.19	3.00	34.77	PASS		
	16QAM	1		0	23.12	-0.46	20.51	3.00	34.77	PASS	
1		24		23.28	-0.46	20.67	3.00	34.77	PASS		
1		49		23.21	-0.46	20.60	3.00	34.77	PASS		
25		0		21.98	-0.46	19.37	3.00	34.77	PASS		
25		12		22.46	-0.46	19.85	3.00	34.77	PASS		
25		24		21.87	-0.46	19.26	3.00	34.77	PASS		
50		0		22.37	-0.46	19.76	3.00	34.77	PASS		



Radiated Power (ERP) for LTE Band 13 /5M										
BW (MHz)	UL Channel	RB Size	RB offset	Modulation	Conduction AVG Power(dBm)	Ant Gain (dBi)	ERP (dBm)	ERP Limit(W)	ERP Limit(dBm)	Verdict
5	Lowest	1	0	QPSK	23.47	-0.67	20.65	3.00	34.77	PASS
		1	12		23.41	-0.67	20.59	3.00	34.77	PASS
		1	24		23.33	-0.67	20.51	3.00	34.77	PASS
		12	0		22.24	-0.67	19.42	3.00	34.77	PASS
		12	6		22.38	-0.67	19.56	3.00	34.77	PASS
		12	11		22.36	-0.67	19.54	3.00	34.77	PASS
		25	0	22.32	-0.67	19.50	3.00	34.77	PASS	
		1	0	22.36	-0.67	19.54	3.00	34.77	PASS	
		1	12	22.48	-0.67	19.66	3.00	34.77	PASS	
		1	24	22.38	-0.67	19.56	3.00	34.77	PASS	
		12	0	21.19	-0.67	18.37	3.00	34.77	PASS	
		12	6	21.16	-0.67	18.34	3.00	34.77	PASS	
		12	11	21.23	-0.67	18.41	3.00	34.77	PASS	
		25	0	21.28	-0.67	18.46	3.00	34.77	PASS	
		1	0	23.25	-0.67	20.43	3.00	34.77	PASS	
		1	12	23.20	-0.67	20.38	3.00	34.77	PASS	
	1	24	23.18	-0.67	20.36	3.00	34.77	PASS		
	12	0	22.17	-0.67	19.35	3.00	34.77	PASS		
	12	6	22.30	-0.67	19.48	3.00	34.77	PASS		
	12	11	22.35	-0.67	19.53	3.00	34.77	PASS		
	25	0	22.23	-0.67	19.41	3.00	34.77	PASS		
	1	0	21.82	-0.67	19.00	3.00	34.77	PASS		
	1	12	21.88	-0.67	19.06	3.00	34.77	PASS		
	1	24	21.64	-0.67	18.82	3.00	34.77	PASS		
	12	0	21.26	-0.67	18.44	3.00	34.77	PASS		
	12	6	21.68	-0.67	18.86	3.00	34.77	PASS		
	12	11	21.22	-0.67	18.40	3.00	34.77	PASS		
	25	0	21.53	-0.67	18.71	3.00	34.77	PASS		
	1	0	23.23	-0.67	20.41	3.00	34.77	PASS		
	1	12	23.23	-0.67	20.41	3.00	34.77	PASS		
	1	24	23.13	-0.67	20.31	3.00	34.77	PASS		
	12	0	22.18	-0.67	19.36	3.00	34.77	PASS		
	12	6	22.13	-0.67	19.31	3.00	34.77	PASS		
	12	11	22.06	-0.67	19.24	3.00	34.77	PASS		
	25	0	22.20	-0.67	19.38	3.00	34.77	PASS		
	1	0	22.61	-0.67	19.79	3.00	34.77	PASS		
	1	12	22.53	-0.67	19.71	3.00	34.77	PASS		
	1	24	22.15	-0.67	19.33	3.00	34.77	PASS		
	12	0	21.11	-0.67	18.29	3.00	34.77	PASS		
	12	6	21.02	-0.67	18.20	3.00	34.77	PASS		
	12	11	21.01	-0.67	18.19	3.00	34.77	PASS		
	25	0	21.18	-0.67	18.36	3.00	34.77	PASS		



Radiated Power (ERP) for LTE Band 13 /10M										
BW (MHz)	UL Channel	RB Size	RB offset	Modulation	Conduction AVG Power(dBm)	Ant Gain (dBi)	ERP (dBm)	ERP Limit(W)	ERP Limit(dBm)	Verdict
10	Middle	1	0	QPSK	23.60	-0.67	20.78	3.00	34.77	PASS
		1	24		23.59	-0.67	20.77	3.00	34.77	PASS
		1	49		23.51	-0.67	20.69	3.00	34.77	PASS
		25	0		22.42	-0.67	19.60	3.00	34.77	PASS
		25	12		22.40	-0.67	19.58	3.00	34.77	PASS
		25	24		22.24	-0.67	19.42	3.00	34.77	PASS
		50	0		22.31	-0.67	19.49	3.00	34.77	PASS
		1	0	16QAM	21.98	-0.67	19.16	3.00	34.77	PASS
		1	24		21.89	-0.67	19.07	3.00	34.77	PASS
		1	49		21.79	-0.67	18.97	3.00	34.77	PASS
		25	0		21.28	-0.67	18.46	3.00	34.77	PASS
		25	12		21.70	-0.67	18.88	3.00	34.77	PASS
		25	24		21.27	-0.67	18.45	3.00	34.77	PASS
		50	0		21.70	-0.67	18.88	3.00	34.77	PASS



Radiated Power (EIRP) for LTE Band 25 /1.4M											
BW (MHz)	UL Channel	RB Size	RB offset	Modulation	Conduction AVG Power(dBm)	Ant Gain (dBi)	EIRP (dBm)	EIRP Limit(W)	EIRP Limit(dBm)	Verdict	
1.4	Lowest	1	0	QPSK	23.14	-0.34	22.80	2.00	33.01	PASS	
		1	2		23.16	-0.34	22.82	2.00	33.01	PASS	
		1	5		23.19	-0.34	22.85	2.00	33.01	PASS	
		3	0		22.89	-0.34	22.55	2.00	33.01	PASS	
		3	1		22.93	-0.34	22.59	2.00	33.01	PASS	
		3	2		22.85	-0.34	22.51	2.00	33.01	PASS	
		6	0	21.94	-0.34	21.60	2.00	33.01	PASS		
		1	0	16QAM	21.94	-0.34	21.60	2.00	33.01	PASS	
		1	2		21.98	-0.34	21.64	2.00	33.01	PASS	
		1	5		22.01	-0.34	21.67	2.00	33.01	PASS	
		3	0		22.09	-0.34	21.75	2.00	33.01	PASS	
		3	1		22.15	-0.34	21.81	2.00	33.01	PASS	
		3	2		22.12	-0.34	21.78	2.00	33.01	PASS	
		6	0	20.83	-0.34	20.49	2.00	33.01	PASS		
		Middle	QPSK	1	0	23.03	-0.34	22.69	2.00	33.01	PASS
	1			2	23.09	-0.34	22.75	2.00	33.01	PASS	
	1			5	23.07	-0.34	22.73	2.00	33.01	PASS	
	3			0	23.10	-0.34	22.76	2.00	33.01	PASS	
	3			1	23.10	-0.34	22.76	2.00	33.01	PASS	
	3			2	23.16	-0.34	22.82	2.00	33.01	PASS	
	6		0	22.11	-0.34	21.77	2.00	33.01	PASS		
	16QAM		1	0	22.13	-0.34	21.79	2.00	33.01	PASS	
			1	2	22.26	-0.34	21.92	2.00	33.01	PASS	
			1	5	22.16	-0.34	21.82	2.00	33.01	PASS	
			3	0	22.19	-0.34	21.85	2.00	33.01	PASS	
			3	1	22.17	-0.34	21.83	2.00	33.01	PASS	
			3	2	22.17	-0.34	21.83	2.00	33.01	PASS	
			6	0	21.18	-0.34	20.84	2.00	33.01	PASS	
			Highest	QPSK	1	0	23.21	-0.34	22.87	2.00	33.01
		1			2	23.26	-0.34	22.92	2.00	33.01	PASS
	1	5			23.18	-0.34	22.84	2.00	33.01	PASS	
	3	0			22.98	-0.34	22.64	2.00	33.01	PASS	
	3	1			23.01	-0.34	22.67	2.00	33.01	PASS	
	3	2			23.06	-0.34	22.72	2.00	33.01	PASS	
	6	0		21.98	-0.34	21.64	2.00	33.01	PASS		
	16QAM	1		0	22.36	-0.34	22.02	2.00	33.01	PASS	
1		2		22.36	-0.34	22.02	2.00	33.01	PASS		
1		5		22.38	-0.34	22.04	2.00	33.01	PASS		
3		0		22.16	-0.34	21.82	2.00	33.01	PASS		
3		1		22.17	-0.34	21.83	2.00	33.01	PASS		
3		2		22.15	-0.34	21.81	2.00	33.01	PASS		
6		0		21.12	-0.34	20.78	2.00	33.01	PASS		



Radiated Power (EIRP) for LTE Band 25 /3M											
BW (MHz)	UL Channel	RB Size	RB offset	Modulation	Conduction AVG Power(dBm)	Ant Gain (dBi)	EIRP (dBm)	EIRP Limit(W)	EIRP Limit(dBm)	Verdict	
3	Lowest	1	0	QPSK	23.11	-0.34	22.77	2.00	33.01	PASS	
		1	7		23.10	-0.34	22.76	2.00	33.01	PASS	
		1	14		23.12	-0.34	22.78	2.00	33.01	PASS	
		8	0		21.86	-0.34	21.52	2.00	33.01	PASS	
		8	4		21.85	-0.34	21.51	2.00	33.01	PASS	
		8	7		21.88	-0.34	21.54	2.00	33.01	PASS	
		15	0	21.92	-0.34	21.58	2.00	33.01	PASS		
		1	0	16QAM	21.65	-0.34	21.31	2.00	33.01	PASS	
		1	7		21.64	-0.34	21.30	2.00	33.01	PASS	
		1	14		21.67	-0.34	21.33	2.00	33.01	PASS	
		8	0		21.07	-0.34	20.73	2.00	33.01	PASS	
		8	4		21.08	-0.34	20.74	2.00	33.01	PASS	
		8	7		21.01	-0.34	20.67	2.00	33.01	PASS	
		15	0	20.78	-0.34	20.44	2.00	33.01	PASS		
		Middle	QPSK	1	0	23.14	-0.34	22.80	2.00	33.01	PASS
	1			7	23.14	-0.34	22.80	2.00	33.01	PASS	
	1			14	23.11	-0.34	22.77	2.00	33.01	PASS	
	8			0	22.14	-0.34	21.80	2.00	33.01	PASS	
	8			4	22.14	-0.34	21.80	2.00	33.01	PASS	
	8			7	22.11	-0.34	21.77	2.00	33.01	PASS	
	15		0	22.10	-0.34	21.76	2.00	33.01	PASS		
	16QAM		1	0	22.12	-0.34	21.78	2.00	33.01	PASS	
			1	7	22.24	-0.34	21.90	2.00	33.01	PASS	
			1	14	22.22	-0.34	21.88	2.00	33.01	PASS	
			8	0	21.18	-0.34	20.84	2.00	33.01	PASS	
			8	4	21.12	-0.34	20.78	2.00	33.01	PASS	
			8	7	21.09	-0.34	20.75	2.00	33.01	PASS	
			15	0	21.16	-0.34	20.82	2.00	33.01	PASS	
			Highest	QPSK	1	0	23.25	-0.34	22.91	2.00	33.01
		1			7	23.29	-0.34	22.95	2.00	33.01	PASS
	1	14			23.21	-0.34	22.87	2.00	33.01	PASS	
	8	0			21.98	-0.34	21.64	2.00	33.01	PASS	
	8	4			21.96	-0.34	21.62	2.00	33.01	PASS	
	8	7			22.03	-0.34	21.69	2.00	33.01	PASS	
	15	0		22.01	-0.34	21.67	2.00	33.01	PASS		
	16QAM	1		0	22.17	-0.34	21.83	2.00	33.01	PASS	
1		7		22.15	-0.34	21.81	2.00	33.01	PASS		
1		14		22.14	-0.34	21.80	2.00	33.01	PASS		
8		0		21.22	-0.34	20.88	2.00	33.01	PASS		
8		4		21.18	-0.34	20.84	2.00	33.01	PASS		
8		7		21.24	-0.34	20.90	2.00	33.01	PASS		
15		0		21.25	-0.34	20.91	2.00	33.01	PASS		



Radiated Power (EIRP) for LTE Band 25 /5M										
BW (MHz)	UL Channel	RB Size	RB offset	Modulation	Conduction AVG Power(dBm)	Ant Gain (dBi)	EIRP (dBm)	EIRP Limit(W)	EIRP Limit(dBm)	Verdict
5	Lowest	1	0	QPSK	22.88	-0.34	22.54	2.00	33.01	PASS
		1	12		22.86	-0.34	22.52	2.00	33.01	PASS
		1	24		22.86	-0.34	22.52	2.00	33.01	PASS
		12	0		21.87	-0.34	21.53	2.00	33.01	PASS
		12	6		21.89	-0.34	21.55	2.00	33.01	PASS
		12	11		21.88	-0.34	21.54	2.00	33.01	PASS
		25	0		21.95	-0.34	21.61	2.00	33.01	PASS
		1	0	16QAM	22.27	-0.34	21.93	2.00	33.01	PASS
		1	12		22.37	-0.34	22.03	2.00	33.01	PASS
		1	24		22.31	-0.34	21.97	2.00	33.01	PASS
		12	0		20.82	-0.34	20.48	2.00	33.01	PASS
		12	6		20.85	-0.34	20.51	2.00	33.01	PASS
		12	11		20.83	-0.34	20.49	2.00	33.01	PASS
		25	0		21.02	-0.34	20.68	2.00	33.01	PASS
	Middle	QPSK	1	0	23.24	-0.34	22.90	2.00	33.01	PASS
			1	12	23.24	-0.34	22.90	2.00	33.01	PASS
			1	24	23.19	-0.34	22.85	2.00	33.01	PASS
			12	0	22.08	-0.34	21.74	2.00	33.01	PASS
			12	6	22.08	-0.34	21.74	2.00	33.01	PASS
			12	11	22.06	-0.34	21.72	2.00	33.01	PASS
			25	0	22.09	-0.34	21.75	2.00	33.01	PASS
		16QAM	1	0	22.23	-0.34	21.89	2.00	33.01	PASS
			1	12	22.32	-0.34	21.98	2.00	33.01	PASS
			1	24	22.26	-0.34	21.92	2.00	33.01	PASS
			12	0	21.08	-0.34	20.74	2.00	33.01	PASS
			12	6	20.99	-0.34	20.65	2.00	33.01	PASS
			12	11	21.06	-0.34	20.72	2.00	33.01	PASS
			25	0	21.09	-0.34	20.75	2.00	33.01	PASS
	Highest	QPSK	1	0	22.93	-0.34	22.59	2.00	33.01	PASS
			1	12	23.11	-0.34	22.77	2.00	33.01	PASS
			1	24	23.04	-0.34	22.70	2.00	33.01	PASS
			12	0	21.93	-0.34	21.59	2.00	33.01	PASS
			12	6	22.09	-0.34	21.75	2.00	33.01	PASS
			12	11	22.02	-0.34	21.68	2.00	33.01	PASS
			25	0	22.00	-0.34	21.66	2.00	33.01	PASS
		16QAM	1	0	21.69	-0.34	21.35	2.00	33.01	PASS
1			12	22.14	-0.34	21.80	2.00	33.01	PASS	
1			24	22.09	-0.34	21.75	2.00	33.01	PASS	
12			0	21.10	-0.34	20.76	2.00	33.01	PASS	
12			6	21.12	-0.34	20.78	2.00	33.01	PASS	
12			11	21.13	-0.34	20.79	2.00	33.01	PASS	
25			0	21.11	-0.34	20.77	2.00	33.01	PASS	



Radiated Power (EIRP) for LTE Band 25 /10M										
BW (MHz)	UL Channel	RB Size	RB offset	Modulation	Conduction AVG Power(dBm)	Ant Gain (dBi)	EIRP (dBm)	EIRP Limit(W)	EIRP Limit(dBm)	Verdict
10	Lowest	1	0	QPSK	23.52	-0.34	23.18	2.00	33.01	PASS
		1	24		23.45	-0.34	23.11	2.00	33.01	PASS
		1	49		23.07	-0.34	22.73	2.00	33.01	PASS
		25	0		22.46	-0.34	22.12	2.00	33.01	PASS
		25	12		21.89	-0.34	21.55	2.00	33.01	PASS
		25	24		22.00	-0.34	21.66	2.00	33.01	PASS
		50	0	22.17	-0.34	21.83	2.00	33.01	PASS	
		1	0	16QAM	22.64	-0.34	22.30	2.00	33.01	PASS
		1	24		23.24	-0.34	22.90	2.00	33.01	PASS
		1	49		23.07	-0.34	22.73	2.00	33.01	PASS
		25	0		21.05	-0.34	20.71	2.00	33.01	PASS
		25	12		21.28	-0.34	20.94	2.00	33.01	PASS
		25	24		21.27	-0.34	20.93	2.00	33.01	PASS
		50	0	21.14	-0.34	20.80	2.00	33.01	PASS	
		1	0	QPSK	23.43	-0.34	23.09	2.00	33.01	PASS
	1	24	23.08		-0.34	22.74	2.00	33.01	PASS	
	1	49	23.15		-0.34	22.81	2.00	33.01	PASS	
	25	0	22.08		-0.34	21.74	2.00	33.01	PASS	
	25	12	22.03		-0.34	21.69	2.00	33.01	PASS	
	25	24	22.05		-0.34	21.71	2.00	33.01	PASS	
	50	0	22.11	-0.34	21.77	2.00	33.01	PASS		
	1	0	16QAM	22.76	-0.34	22.42	2.00	33.01	PASS	
	1	24		22.76	-0.34	22.42	2.00	33.01	PASS	
	1	49		22.83	-0.34	22.49	2.00	33.01	PASS	
	25	0		21.22	-0.34	20.88	2.00	33.01	PASS	
	25	12		21.23	-0.34	20.89	2.00	33.01	PASS	
	25	24		21.22	-0.34	20.88	2.00	33.01	PASS	
	50	0	21.18	-0.34	20.84	2.00	33.01	PASS		
	1	0	QPSK	23.26	-0.34	22.92	2.00	33.01	PASS	
	1	24		23.25	-0.34	22.91	2.00	33.01	PASS	
	1	49		23.31	-0.34	22.97	2.00	33.01	PASS	
	25	0		22.01	-0.34	21.67	2.00	33.01	PASS	
	25	12		22.01	-0.34	21.67	2.00	33.01	PASS	
	25	24		22.06	-0.34	21.72	2.00	33.01	PASS	
	50	0	21.98	-0.34	21.64	2.00	33.01	PASS		
	1	0	16QAM	22.24	-0.34	21.90	2.00	33.01	PASS	
	1	24		22.47	-0.34	22.13	2.00	33.01	PASS	
	1	49		22.47	-0.34	22.13	2.00	33.01	PASS	
	25	0		21.13	-0.34	20.79	2.00	33.01	PASS	
	25	12		21.16	-0.34	20.82	2.00	33.01	PASS	
	25	24		21.15	-0.34	20.81	2.00	33.01	PASS	
	50	0	21.15	-0.34	20.81	2.00	33.01	PASS		



Radiated Power (EIRP) for LTE Band 25 /15M											
BW (MHz)	UL Channel	RB Size	RB offset	Modulation	Conduction AVG Power(dBm)	Ant Gain (dBi)	EIRP (dBm)	EIRP Limit(W)	EIRP Limit(dBm)	Verdict	
15	Lowest	1	0	QPSK	22.98	-0.34	22.64	2.00	33.01	PASS	
		1	37		22.98	-0.34	22.64	2.00	33.01	PASS	
		1	74		23.03	-0.34	22.69	2.00	33.01	PASS	
		36	0		21.85	-0.34	21.51	2.00	33.01	PASS	
		36	18		21.82	-0.34	21.48	2.00	33.01	PASS	
		36	39		21.89	-0.34	21.55	2.00	33.01	PASS	
		75	0	21.88	-0.34	21.54	2.00	33.01	PASS		
		1	0	16QAM	21.76	-0.34	21.42	2.00	33.01	PASS	
		1	37		21.74	-0.34	21.40	2.00	33.01	PASS	
		1	74		21.80	-0.34	21.46	2.00	33.01	PASS	
		36	0		20.92	-0.34	20.58	2.00	33.01	PASS	
		36	18		20.90	-0.34	20.56	2.00	33.01	PASS	
		36	39		20.98	-0.34	20.64	2.00	33.01	PASS	
		75	0	20.99	-0.34	20.65	2.00	33.01	PASS		
		Middle	QPSK	1	0	23.31	-0.34	22.97	2.00	33.01	PASS
	1			37	23.37	-0.34	23.03	2.00	33.01	PASS	
	1			74	23.38	-0.34	23.04	2.00	33.01	PASS	
	36			0	22.08	-0.34	21.74	2.00	33.01	PASS	
	36			18	22.09	-0.34	21.75	2.00	33.01	PASS	
	36			39	22.11	-0.34	21.77	2.00	33.01	PASS	
	75		0	22.04	-0.34	21.70	2.00	33.01	PASS		
	16QAM		1	0	21.87	-0.34	21.53	2.00	33.01	PASS	
			1	37	21.86	-0.34	21.52	2.00	33.01	PASS	
			1	74	21.81	-0.34	21.47	2.00	33.01	PASS	
			36	0	21.24	-0.34	20.90	2.00	33.01	PASS	
			36	18	21.14	-0.34	20.80	2.00	33.01	PASS	
			36	39	21.25	-0.34	20.91	2.00	33.01	PASS	
			75	0	21.09	-0.34	20.75	2.00	33.01	PASS	
			Highest	QPSK	1	0	23.00	-0.34	22.66	2.00	33.01
		1			37	23.05	-0.34	22.71	2.00	33.01	PASS
	1	74			23.08	-0.34	22.74	2.00	33.01	PASS	
	36	0			22.06	-0.34	21.72	2.00	33.01	PASS	
	36	18			22.05	-0.34	21.71	2.00	33.01	PASS	
	36	39			22.03	-0.34	21.69	2.00	33.01	PASS	
	75	0		22.11	-0.34	21.77	2.00	33.01	PASS		
	16QAM	1		0	22.67	-0.34	22.33	2.00	33.01	PASS	
1		37		22.67	-0.34	22.33	2.00	33.01	PASS		
1		74		22.60	-0.34	22.26	2.00	33.01	PASS		
36		0		21.20	-0.34	20.86	2.00	33.01	PASS		
36		18		21.21	-0.34	20.87	2.00	33.01	PASS		
36		39		21.20	-0.34	20.86	2.00	33.01	PASS		
75		0		21.12	-0.34	20.78	2.00	33.01	PASS		



Radiated Power (EIRP) for LTE Band 25 /20M										
BW (MHz)	UL Channel	RB Size	RB offset	Modulation	Conduction AVG Power(dBm)	Ant Gain (dBi)	EIRP (dBm)	EIRP Limit(W)	EIRP Limit(dBm)	Verdict
20	Lowest	1	0	QPSK	21.12	-0.34	20.78	2.00	33.01	PASS
		1	49		22.99	-0.34	22.65	2.00	33.01	PASS
		1	99		23.02	-0.34	22.68	2.00	33.01	PASS
		50	0		23.18	-0.34	22.84	2.00	33.01	PASS
		50	24		21.92	-0.34	21.58	2.00	33.01	PASS
		50	49		21.87	-0.34	21.53	2.00	33.01	PASS
		100	0	22.04	-0.34	21.70	2.00	33.01	PASS	
		1	0	16QAM	22.02	-0.34	21.68	2.00	33.01	PASS
		1	49		22.19	-0.34	21.85	2.00	33.01	PASS
		1	99		22.17	-0.34	21.83	2.00	33.01	PASS
		50	0		22.28	-0.34	21.94	2.00	33.01	PASS
		50	24		21.05	-0.34	20.71	2.00	33.01	PASS
		50	49		21.06	-0.34	20.72	2.00	33.01	PASS
		100	0	21.05	-0.34	20.71	2.00	33.01	PASS	
		1	0	QPSK	21.04	-0.34	20.70	2.00	33.01	PASS
	1	49	23.32		-0.34	22.98	2.00	33.01	PASS	
	1	99	23.33		-0.34	22.99	2.00	33.01	PASS	
	50	0	23.39		-0.34	23.05	2.00	33.01	PASS	
	50	24	22.12		-0.34	21.78	2.00	33.01	PASS	
	50	49	22.07		-0.34	21.73	2.00	33.01	PASS	
	100	0	22.10	-0.34	21.76	2.00	33.01	PASS		
	1	0	16QAM	22.06	-0.34	21.72	2.00	33.01	PASS	
	1	49		22.16	-0.34	21.82	2.00	33.01	PASS	
	1	99		22.12	-0.34	21.78	2.00	33.01	PASS	
	50	0		22.21	-0.34	21.87	2.00	33.01	PASS	
	50	24		21.17	-0.34	20.83	2.00	33.01	PASS	
	50	49		21.18	-0.34	20.84	2.00	33.01	PASS	
	100	0	21.21	-0.34	20.87	2.00	33.01	PASS		
	1	0	QPSK	21.11	-0.34	20.77	2.00	33.01	PASS	
	1	49		23.12	-0.34	22.78	2.00	33.01	PASS	
	1	99		23.13	-0.34	22.79	2.00	33.01	PASS	
	50	0		23.20	-0.34	22.86	2.00	33.01	PASS	
	50	24		22.04	-0.34	21.70	2.00	33.01	PASS	
	50	49		22.02	-0.34	21.68	2.00	33.01	PASS	
	100	0	22.13	-0.34	21.79	2.00	33.01	PASS		
	1	0	16QAM	22.12	-0.34	21.78	2.00	33.01	PASS	
	1	49		22.10	-0.34	21.76	2.00	33.01	PASS	
	1	99		22.25	-0.34	21.91	2.00	33.01	PASS	
	50	0		22.48	-0.34	22.14	2.00	33.01	PASS	
	50	24		21.17	-0.34	20.83	2.00	33.01	PASS	
	50	49		21.25	-0.34	20.91	2.00	33.01	PASS	
	100	0	21.23	-0.34	20.89	2.00	33.01	PASS		



Radiated Power (ERP) for LTE Band 26 Part22 /1.4M											
BW (MHz)	UL Channel	RB Size	RB offset	Modulation	Conduction AVG Power(dBm)	Ant Gain (dBi)	ERP (dBm)	ERP Limit(W)	ERP Limit(dBm)	Verdict	
1.4	Lowest	1	0	QPSK	24.14	-0.43	21.56	7.00	38.45	PASS	
		1	2		24.16	-0.43	21.58	7.00	38.45	PASS	
		1	5		24.10	-0.43	21.52	7.00	38.45	PASS	
		3	0		23.42	-0.43	20.84	7.00	38.45	PASS	
		3	1		23.46	-0.43	20.88	7.00	38.45	PASS	
		3	2		23.47	-0.43	20.89	7.00	38.45	PASS	
		6	0	21.40	-0.43	18.82	7.00	38.45	PASS		
		1	0	16QAM	23.99	-0.43	21.41	7.00	38.45	PASS	
		1	2		24.07	-0.43	21.49	7.00	38.45	PASS	
		1	5		23.96	-0.43	21.38	7.00	38.45	PASS	
		3	0		22.25	-0.43	19.67	7.00	38.45	PASS	
		3	1		22.24	-0.43	19.66	7.00	38.45	PASS	
		3	2		22.26	-0.43	19.68	7.00	38.45	PASS	
		6	0	21.45	-0.43	18.87	7.00	38.45	PASS		
		Middle	QPSK	1	0	23.94	-0.43	21.36	7.00	38.45	PASS
				1	2	23.97	-0.43	21.39	7.00	38.45	PASS
				1	5	24.00	-0.43	21.42	7.00	38.45	PASS
				3	0	23.45	-0.43	20.87	7.00	38.45	PASS
	3			1	23.45	-0.43	20.87	7.00	38.45	PASS	
	3			2	23.53	-0.43	20.95	7.00	38.45	PASS	
	6		0	21.35	-0.43	18.77	7.00	38.45	PASS		
	16QAM		1	0	24.10	-0.43	21.52	7.00	38.45	PASS	
			1	2	23.97	-0.43	21.39	7.00	38.45	PASS	
			1	5	23.92	-0.43	21.34	7.00	38.45	PASS	
			3	0	22.35	-0.43	19.77	7.00	38.45	PASS	
			3	1	22.43	-0.43	19.85	7.00	38.45	PASS	
			3	2	22.49	-0.43	19.91	7.00	38.45	PASS	
	6		0	21.57	-0.43	18.99	7.00	38.45	PASS		
	Highest		QPSK	1	0	24.12	-0.43	21.54	7.00	38.45	PASS
				1	2	24.24	-0.43	21.66	7.00	38.45	PASS
				1	5	24.04	-0.43	21.46	7.00	38.45	PASS
				3	0	23.58	-0.43	21.00	7.00	38.45	PASS
		3		1	23.63	-0.43	21.05	7.00	38.45	PASS	
		3		2	23.58	-0.43	21.00	7.00	38.45	PASS	
		6	0	21.48	-0.43	18.90	7.00	38.45	PASS		
		16QAM	1	0	23.73	-0.43	21.15	7.00	38.45	PASS	
			1	2	23.80	-0.43	21.22	7.00	38.45	PASS	
			1	5	23.85	-0.43	21.27	7.00	38.45	PASS	
			3	0	22.47	-0.43	19.89	7.00	38.45	PASS	
			3	1	22.54	-0.43	19.96	7.00	38.45	PASS	
			3	2	22.54	-0.43	19.96	7.00	38.45	PASS	
		6	0	21.79	-0.43	19.21	7.00	38.45	PASS		



Radiated Power (ERP) for LTE Band 26 Part22 /3M										
BW (MHz)	UL Channel	RB Size	RB offset	Modulation	Conduction AVG Power(dBm)	Ant Gain (dBi)	ERP (dBm)	ERP Limit(W)	ERP Limit(dBm)	Verdict
3	Lowest	1	0	QPSK	24.12	-0.43	21.54	7.00	38.45	PASS
		1	7		24.06	-0.43	21.48	7.00	38.45	PASS
		1	14		24.15	-0.43	21.57	7.00	38.45	PASS
		8	0		21.41	-0.43	18.83	7.00	38.45	PASS
		8	4		21.33	-0.43	18.75	7.00	38.45	PASS
		8	7		21.29	-0.43	18.71	7.00	38.45	PASS
		15	0	21.48	-0.43	18.90	7.00	38.45	PASS	
		1	0	16QAM	23.08	-0.43	20.50	7.00	38.45	PASS
		1	7		23.18	-0.43	20.60	7.00	38.45	PASS
		1	14		23.16	-0.43	20.58	7.00	38.45	PASS
		8	0		21.35	-0.43	18.77	7.00	38.45	PASS
		8	4		21.27	-0.43	18.69	7.00	38.45	PASS
		8	7		21.29	-0.43	18.71	7.00	38.45	PASS
		15	0	21.52	-0.43	18.94	7.00	38.45	PASS	
		Middle	QPSK	1	0	23.97	-0.43	21.39	7.00	38.45
	1			7	23.94	-0.43	21.36	7.00	38.45	PASS
	1			14	23.92	-0.43	21.34	7.00	38.45	PASS
	8			0	21.38	-0.43	18.80	7.00	38.45	PASS
	8			4	21.40	-0.43	18.82	7.00	38.45	PASS
	8			7	21.36	-0.43	18.78	7.00	38.45	PASS
	15		0	21.36	-0.43	18.78	7.00	38.45	PASS	
	16QAM		1	0	23.94	-0.43	21.36	7.00	38.45	PASS
			1	7	23.98	-0.43	21.40	7.00	38.45	PASS
			1	14	23.99	-0.43	21.41	7.00	38.45	PASS
			8	0	21.43	-0.43	18.85	7.00	38.45	PASS
			8	4	21.44	-0.43	18.86	7.00	38.45	PASS
			8	7	21.40	-0.43	18.82	7.00	38.45	PASS
	15		0	21.46	-0.43	18.88	7.00	38.45	PASS	
	Highest		QPSK	1	0	24.15	-0.43	21.57	7.00	38.45
		1		7	24.17	-0.43	21.59	7.00	38.45	PASS
		1		14	24.14	-0.43	21.56	7.00	38.45	PASS
		8		0	21.54	-0.43	18.96	7.00	38.45	PASS
		8		4	21.38	-0.43	18.80	7.00	38.45	PASS
		8		7	21.49	-0.43	18.91	7.00	38.45	PASS
		15	0	21.55	-0.43	18.97	7.00	38.45	PASS	
		16QAM	1	0	23.73	-0.43	21.15	7.00	38.45	PASS
1			7	23.71	-0.43	21.13	7.00	38.45	PASS	
1			14	23.80	-0.43	21.22	7.00	38.45	PASS	
8			0	21.34	-0.43	18.76	7.00	38.45	PASS	
8			4	21.32	-0.43	18.74	7.00	38.45	PASS	
8			7	21.65	-0.43	19.07	7.00	38.45	PASS	
15		0	21.47	-0.43	18.89	7.00	38.45	PASS		



Radiated Power (ERP) for LTE Band 26 Part22 /5M										
BW (MHz)	UL Channel	RB Size	RB offset	Modulation	Conduction AVG Power(dBm)	Ant Gain (dBi)	ERP (dBm)	ERP Limit(W)	ERP Limit(dBm)	Verdict
5	Lowest	1	0	QPSK	23.87	-0.43	21.29	7.00	38.45	PASS
		1	12		23.83	-0.43	21.25	7.00	38.45	PASS
		1	24		23.84	-0.43	21.26	7.00	38.45	PASS
		12	0		21.41	-0.43	18.83	7.00	38.45	PASS
		12	6		21.33	-0.43	18.75	7.00	38.45	PASS
		12	11		21.29	-0.43	18.71	7.00	38.45	PASS
		25	0		21.44	-0.43	18.86	7.00	38.45	PASS
		1	0	16QAM	23.70	-0.43	21.12	7.00	38.45	PASS
		1	12		23.63	-0.43	21.05	7.00	38.45	PASS
		1	24		23.70	-0.43	21.12	7.00	38.45	PASS
		12	0		21.35	-0.43	18.77	7.00	38.45	PASS
		12	6		21.22	-0.43	18.64	7.00	38.45	PASS
		12	11		21.24	-0.43	18.66	7.00	38.45	PASS
		25	0		21.48	-0.43	18.90	7.00	38.45	PASS
	Middle	QPSK	1	0	24.06	-0.43	21.48	7.00	38.45	PASS
			1	12	24.13	-0.43	21.55	7.00	38.45	PASS
			1	24	24.13	-0.43	21.55	7.00	38.45	PASS
			12	0	21.41	-0.43	18.83	7.00	38.45	PASS
			12	6	21.40	-0.43	18.82	7.00	38.45	PASS
			12	11	21.53	-0.43	18.95	7.00	38.45	PASS
			25	0	21.46	-0.43	18.88	7.00	38.45	PASS
		16QAM	1	0	23.59	-0.43	21.01	7.00	38.45	PASS
			1	12	23.64	-0.43	21.06	7.00	38.45	PASS
			1	24	23.63	-0.43	21.05	7.00	38.45	PASS
			12	0	21.43	-0.43	18.85	7.00	38.45	PASS
			12	6	21.26	-0.43	18.68	7.00	38.45	PASS
			12	11	21.37	-0.43	18.79	7.00	38.45	PASS
			25	0	21.37	-0.43	18.79	7.00	38.45	PASS
	Highest	QPSK	1	0	24.01	-0.43	21.43	7.00	38.45	PASS
			1	12	23.84	-0.43	21.26	7.00	38.45	PASS
			1	24	23.93	-0.43	21.35	7.00	38.45	PASS
			12	0	21.49	-0.43	18.91	7.00	38.45	PASS
			12	6	21.46	-0.43	18.88	7.00	38.45	PASS
			12	11	21.45	-0.43	18.87	7.00	38.45	PASS
			25	0	21.49	-0.43	18.91	7.00	38.45	PASS
		16QAM	1	0	23.23	-0.43	20.65	7.00	38.45	PASS
1			12	23.04	-0.43	20.46	7.00	38.45	PASS	
1			24	23.57	-0.43	20.99	7.00	38.45	PASS	
12			0	21.57	-0.43	18.99	7.00	38.45	PASS	
12			6	21.49	-0.43	18.91	7.00	38.45	PASS	
12			11	21.38	-0.43	18.80	7.00	38.45	PASS	
25			0	21.30	-0.43	18.72	7.00	38.45	PASS	



Radiated Power (ERP) for LTE Band 26 Part22 /10M										
BW (MHz)	UL Channel	RB Size	RB offset	Modulation	Conduction AVG Power(dBm)	Ant Gain (dBi)	ERP (dBm)	ERP Limit(W)	ERP Limit(dBm)	Verdict
10	Lowest	1	0	QPSK	24.08	-0.43	21.50	7.00	38.45	PASS
		1	24		24.14	-0.43	21.56	7.00	38.45	PASS
		1	49		24.18	-0.43	21.60	7.00	38.45	PASS
		25	0		21.84	-0.43	19.26	7.00	38.45	PASS
		25	12		21.79	-0.43	19.21	7.00	38.45	PASS
		25	24		21.98	-0.43	19.40	7.00	38.45	PASS
		50	0	21.89	-0.43	19.31	7.00	38.45	PASS	
		1	0	16QAM	23.15	-0.43	20.57	7.00	38.45	PASS
		1	24		23.08	-0.43	20.50	7.00	38.45	PASS
		1	49		23.15	-0.43	20.57	7.00	38.45	PASS
		25	0		21.90	-0.43	19.32	7.00	38.45	PASS
		25	12		21.84	-0.43	19.26	7.00	38.45	PASS
		25	24		21.95	-0.43	19.37	7.00	38.45	PASS
		50	0	21.88	-0.43	19.30	7.00	38.45	PASS	
		1	0	QPSK	23.90	-0.43	21.32	7.00	38.45	PASS
	1	24	23.93		-0.43	21.35	7.00	38.45	PASS	
	1	49	24.03		-0.43	21.45	7.00	38.45	PASS	
	25	0	22.03		-0.43	19.45	7.00	38.45	PASS	
	25	12	21.97		-0.43	19.39	7.00	38.45	PASS	
	25	24	22.03		-0.43	19.45	7.00	38.45	PASS	
	50	0	21.96	-0.43	19.38	7.00	38.45	PASS		
	1	0	16QAM	23.81	-0.43	21.23	7.00	38.45	PASS	
	1	24		23.97	-0.43	21.39	7.00	38.45	PASS	
	1	49		24.02	-0.43	21.44	7.00	38.45	PASS	
	25	0		22.09	-0.43	19.51	7.00	38.45	PASS	
	25	12		22.03	-0.43	19.45	7.00	38.45	PASS	
	25	24		22.02	-0.43	19.44	7.00	38.45	PASS	
	50	0	21.99	-0.43	19.41	7.00	38.45	PASS		
	1	0	QPSK	24.08	-0.43	21.50	7.00	38.45	PASS	
	1	24		24.12	-0.43	21.54	7.00	38.45	PASS	
	1	49		24.15	-0.43	21.57	7.00	38.45	PASS	
	25	0		22.00	-0.43	19.42	7.00	38.45	PASS	
	25	12		21.99	-0.43	19.41	7.00	38.45	PASS	
	25	24		21.98	-0.43	19.40	7.00	38.45	PASS	
	50	0	21.95	-0.43	19.37	7.00	38.45	PASS		
	1	0	16QAM	23.58	-0.43	21.00	7.00	38.45	PASS	
1	24	23.61		-0.43	21.03	7.00	38.45	PASS		
1	49	23.63		-0.43	21.05	7.00	38.45	PASS		
25	0	22.02		-0.43	19.44	7.00	38.45	PASS		
25	12	22.05		-0.43	19.47	7.00	38.45	PASS		
25	24	22.09		-0.43	19.51	7.00	38.45	PASS		
50	0	21.97	-0.43	19.39	7.00	38.45	PASS			



Radiated Power (ERP) for LTE Band 26 Part22 /15M										
BW (MHz)	UL Channel	RB Size	RB offset	Modulation	Conduction AVG Power(dBm)	Ant Gain (dBi)	ERP (dBm)	ERP Limit(W)	ERP Limit(dBm)	Verdict
15	Lowest	1	0	QPSK	24.14	-0.43	21.56	7.00	38.45	PASS
		1	24		24.18	-0.43	21.60	7.00	38.45	PASS
		1	49		24.26	-0.43	21.68	7.00	38.45	PASS
		25	0		21.88	-0.43	19.30	7.00	38.45	PASS
		25	12		21.97	-0.43	19.39	7.00	38.45	PASS
		25	24		22.05	-0.43	19.47	7.00	38.45	PASS
		50	0	21.89	-0.43	19.31	7.00	38.45	PASS	
		1	0	16QAM	23.12	-0.43	20.54	7.00	38.45	PASS
		1	24		23.17	-0.43	20.59	7.00	38.45	PASS
		1	49		23.24	-0.43	20.66	7.00	38.45	PASS
		25	0		21.83	-0.43	19.25	7.00	38.45	PASS
		25	12		21.93	-0.43	19.35	7.00	38.45	PASS
		25	24		22.02	-0.43	19.44	7.00	38.45	PASS
		50	0	21.92	-0.43	19.34	7.00	38.45	PASS	
		1	0	QPSK	23.91	-0.43	21.33	7.00	38.45	PASS
	1	24	23.91		-0.43	21.33	7.00	38.45	PASS	
	1	49	24.00		-0.43	21.42	7.00	38.45	PASS	
	25	0	21.95		-0.43	19.37	7.00	38.45	PASS	
	25	12	22.02		-0.43	19.44	7.00	38.45	PASS	
	25	24	22.02		-0.43	19.44	7.00	38.45	PASS	
	50	0	22.00	-0.43	19.42	7.00	38.45	PASS		
	1	0	16QAM	23.89	-0.43	21.31	7.00	38.45	PASS	
	1	24		24.01	-0.43	21.43	7.00	38.45	PASS	
	1	49		23.98	-0.43	21.40	7.00	38.45	PASS	
	25	0		21.91	-0.43	19.33	7.00	38.45	PASS	
	25	12		22.04	-0.43	19.46	7.00	38.45	PASS	
	25	24		22.04	-0.43	19.46	7.00	38.45	PASS	
	50	0	21.96	-0.43	19.38	7.00	38.45	PASS		
	1	0	QPSK	24.19	-0.43	21.61	7.00	38.45	PASS	
	1	24		24.22	-0.43	21.64	7.00	38.45	PASS	
	1	49		24.29	-0.43	21.71	7.00	38.45	PASS	
	25	0		21.98	-0.43	19.40	7.00	38.45	PASS	
	25	12		22.04	-0.43	19.46	7.00	38.45	PASS	
	25	24		22.03	-0.43	19.45	7.00	38.45	PASS	
	50	0	21.94	-0.43	19.36	7.00	38.45	PASS		
	1	0	16QAM	23.48	-0.43	20.90	7.00	38.45	PASS	
1	24	23.62		-0.43	21.04	7.00	38.45	PASS		
1	49	23.70		-0.43	21.12	7.00	38.45	PASS		
25	0	22.05		-0.43	19.47	7.00	38.45	PASS		
25	12	21.99		-0.43	19.41	7.00	38.45	PASS		
25	24	22.05		-0.43	19.47	7.00	38.45	PASS		
50	0	22.04	-0.43	19.46	7.00	38.45	PASS			



Radiated Power (ERP) for LTE Band 26 Part90 /1.4M										
BW (MHz)	UL Channel	RB Size	RB offset	Modulation	Conduction AVG Power(dBm)	Ant Gain (dBi)	ERP (dBm)	ERP Limit(W)	ERP Limit(dBm)	Verdict
1.4	Lowest	1	0	QPSK	24.09	-0.43	21.51	100.00	50.00	PASS
		1	2		24.06	-0.43	21.48	100.00	50.00	PASS
		1	5		24.04	-0.43	21.46	100.00	50.00	PASS
		3	0		23.41	-0.43	20.83	100.00	50.00	PASS
		3	1		23.35	-0.43	20.77	100.00	50.00	PASS
		3	2		23.33	-0.43	20.75	100.00	50.00	PASS
		6	0	21.36	-0.43	18.78	100.00	50.00	PASS	
		1	0	16QAM	23.64	-0.43	21.06	100.00	50.00	PASS
		1	2		23.66	-0.43	21.08	100.00	50.00	PASS
		1	5		23.64	-0.43	21.06	100.00	50.00	PASS
		3	0		22.54	-0.43	19.96	100.00	50.00	PASS
		3	1		22.48	-0.43	19.90	100.00	50.00	PASS
		3	2		22.50	-0.43	19.92	100.00	50.00	PASS
		6	0	21.50	-0.43	18.92	100.00	50.00	PASS	
		1	0	QPSK	24.02	-0.43	21.44	100.00	50.00	PASS
	1	2	23.92		-0.43	21.34	100.00	50.00	PASS	
	1	5	23.95		-0.43	21.37	100.00	50.00	PASS	
	3	0	23.45		-0.43	20.87	100.00	50.00	PASS	
	3	1	23.39		-0.43	20.81	100.00	50.00	PASS	
	3	2	23.38		-0.43	20.80	100.00	50.00	PASS	
	6	0	21.30	-0.43	18.72	100.00	50.00	PASS		
	1	0	16QAM	23.90	-0.43	21.32	100.00	50.00	PASS	
	1	2		24.11	-0.43	21.53	100.00	50.00	PASS	
	1	5		23.70	-0.43	21.12	100.00	50.00	PASS	
	3	0		22.33	-0.43	19.75	100.00	50.00	PASS	
	3	1		22.36	-0.43	19.78	100.00	50.00	PASS	
	3	2		22.29	-0.43	19.71	100.00	50.00	PASS	
	6	0	21.32	-0.43	18.74	100.00	50.00	PASS		
	1	0	QPSK	23.84	-0.43	21.26	100.00	50.00	PASS	
	1	2		23.84	-0.43	21.26	100.00	50.00	PASS	
	1	5		23.81	-0.43	21.23	100.00	50.00	PASS	
	3	0		23.44	-0.43	20.86	100.00	50.00	PASS	
	3	1		23.39	-0.43	20.81	100.00	50.00	PASS	
	3	2		23.35	-0.43	20.77	100.00	50.00	PASS	
	6	0	21.32	-0.43	18.74	100.00	50.00	PASS		
	1	0	16QAM	23.89	-0.43	21.31	100.00	50.00	PASS	
	1	2		23.86	-0.43	21.28	100.00	50.00	PASS	
	1	5		23.86	-0.43	21.28	100.00	50.00	PASS	
	3	0		22.31	-0.43	19.73	100.00	50.00	PASS	
	3	1		22.32	-0.43	19.74	100.00	50.00	PASS	
	3	2		22.27	-0.43	19.69	100.00	50.00	PASS	
	6	0	21.30	-0.43	18.72	100.00	50.00	PASS		



Radiated Power (ERP) for LTE Band 26 Part90 /3M											
BW (MHz)	UL Channel	RB Size	RB offset	Modulation	Conduction AVG Power(dBm)	Ant Gain (dBi)	ERP (dBm)	ERP Limit(W)	ERP Limit(dBm)	Verdict	
3	Lowest	1	0	QPSK	24.08	-0.43	21.50	100.00	50.00	PASS	
		1	7		24.11	-0.43	21.53	100.00	50.00	PASS	
		1	14		24.10	-0.43	21.52	100.00	50.00	PASS	
		8	0		21.30	-0.43	18.72	100.00	50.00	PASS	
		8	4		21.36	-0.43	18.78	100.00	50.00	PASS	
		8	7		21.39	-0.43	18.81	100.00	50.00	PASS	
		15	0	21.36	-0.43	18.78	100.00	50.00	PASS		
		1	0	16QAM	23.70	-0.43	21.12	100.00	50.00	PASS	
		1	7		23.63	-0.43	21.05	100.00	50.00	PASS	
		1	14		23.70	-0.43	21.12	100.00	50.00	PASS	
		8	0		21.28	-0.43	18.70	100.00	50.00	PASS	
		8	4		21.32	-0.43	18.74	100.00	50.00	PASS	
		8	7		21.32	-0.43	18.74	100.00	50.00	PASS	
		15	0	21.35	-0.43	18.77	100.00	50.00	PASS		
		Middle	QPSK	1	0	24.00	-0.43	21.42	100.00	50.00	PASS
	1			7	23.96	-0.43	21.38	100.00	50.00	PASS	
	1			14	23.93	-0.43	21.35	100.00	50.00	PASS	
	8			0	21.26	-0.43	18.68	100.00	50.00	PASS	
	8			4	21.28	-0.43	18.70	100.00	50.00	PASS	
	8			7	21.28	-0.43	18.70	100.00	50.00	PASS	
	15		0	21.28	-0.43	18.70	100.00	50.00	PASS		
	16QAM		1	0	23.01	-0.43	20.43	100.00	50.00	PASS	
			1	7	23.06	-0.43	20.48	100.00	50.00	PASS	
			1	14	23.01	-0.43	20.43	100.00	50.00	PASS	
			8	0	21.42	-0.43	18.84	100.00	50.00	PASS	
			8	4	21.28	-0.43	18.70	100.00	50.00	PASS	
			8	7	21.25	-0.43	18.67	100.00	50.00	PASS	
			15	0	21.21	-0.43	18.63	100.00	50.00	PASS	
			Highest	QPSK	1	0	23.84	-0.43	21.26	100.00	50.00
		1			7	23.91	-0.43	21.33	100.00	50.00	PASS
	1	14			23.78	-0.43	21.20	100.00	50.00	PASS	
	8	0			21.45	-0.43	18.87	100.00	50.00	PASS	
	8	4			21.40	-0.43	18.82	100.00	50.00	PASS	
	8	7			21.42	-0.43	18.84	100.00	50.00	PASS	
	15	0		21.42	-0.43	18.84	100.00	50.00	PASS		
	16QAM	1		0	23.87	-0.43	21.29	100.00	50.00	PASS	
1		7		23.86	-0.43	21.28	100.00	50.00	PASS		
1		14		23.80	-0.43	21.22	100.00	50.00	PASS		
8		0		21.32	-0.43	18.74	100.00	50.00	PASS		
8		4		21.36	-0.43	18.78	100.00	50.00	PASS		
8		7		21.32	-0.43	18.74	100.00	50.00	PASS		
15		0		21.32	-0.43	18.74	100.00	50.00	PASS		



Radiated Power (ERP) for LTE Band 26 Part90 /5M											
BW (MHz)	UL Channel	RB Size	RB offset	Modulation	Conduction AVG Power(dBm)	Ant Gain (dBi)	ERP (dBm)	ERP Limit(W)	ERP Limit(dBm)	Verdict	
5	Lowest	1	0	QPSK	21.62	-0.43	19.04	100.00	50.00	PASS	
		1	12		22.00	-0.43	19.42	100.00	50.00	PASS	
		1	24		22.03	-0.43	19.45	100.00	50.00	PASS	
		12	0		21.38	-0.43	18.80	100.00	50.00	PASS	
		12	6		21.35	-0.43	18.77	100.00	50.00	PASS	
		12	11		21.24	-0.43	18.66	100.00	50.00	PASS	
		25	0	21.31	-0.43	18.73	100.00	50.00	PASS		
		1	0	16QAM	23.17	-0.43	20.59	100.00	50.00	PASS	
		1	12		23.36	-0.43	20.78	100.00	50.00	PASS	
		1	24		23.37	-0.43	20.79	100.00	50.00	PASS	
		12	0		21.45	-0.43	18.87	100.00	50.00	PASS	
		12	6		21.43	-0.43	18.85	100.00	50.00	PASS	
		12	11		21.50	-0.43	18.92	100.00	50.00	PASS	
		25	0	21.38	-0.43	18.80	100.00	50.00	PASS		
		Middle	QPSK	1	0	23.70	-0.43	21.12	100.00	50.00	PASS
				1	12	23.72	-0.43	21.14	100.00	50.00	PASS
				1	24	23.77	-0.43	21.19	100.00	50.00	PASS
				12	0	21.21	-0.43	18.63	100.00	50.00	PASS
	12			6	21.30	-0.43	18.72	100.00	50.00	PASS	
	12			11	21.35	-0.43	18.77	100.00	50.00	PASS	
	25		0	21.23	-0.43	18.65	100.00	50.00	PASS		
	16QAM		1	0	23.34	-0.43	20.76	100.00	50.00	PASS	
			1	12	23.22	-0.43	20.64	100.00	50.00	PASS	
			1	24	23.18	-0.43	20.60	100.00	50.00	PASS	
			12	0	21.24	-0.43	18.66	100.00	50.00	PASS	
			12	6	21.26	-0.43	18.68	100.00	50.00	PASS	
			12	11	21.29	-0.43	18.71	100.00	50.00	PASS	
	25		0	21.48	-0.43	18.90	100.00	50.00	PASS		
	Highest		QPSK	1	0	23.98	-0.43	21.40	100.00	50.00	PASS
				1	12	23.99	-0.43	21.41	100.00	50.00	PASS
				1	24	23.91	-0.43	21.33	100.00	50.00	PASS
				12	0	21.38	-0.43	18.80	100.00	50.00	PASS
		12		6	21.46	-0.43	18.88	100.00	50.00	PASS	
		12		11	21.31	-0.43	18.73	100.00	50.00	PASS	
		25	0	21.36	-0.43	18.78	100.00	50.00	PASS		
		16QAM	1	0	23.47	-0.43	20.89	100.00	50.00	PASS	
			1	12	23.50	-0.43	20.92	100.00	50.00	PASS	
			1	24	23.43	-0.43	20.85	100.00	50.00	PASS	
			12	0	21.32	-0.43	18.74	100.00	50.00	PASS	
			12	6	21.41	-0.43	18.83	100.00	50.00	PASS	
			12	11	21.38	-0.43	18.80	100.00	50.00	PASS	
		25	0	21.28	-0.43	18.70	100.00	50.00	PASS		



Radiated Power (ERP) for LTE Band 26 Part90 /10M										
BW (MHz)	UL Channel	RB Size	RB offset	Modulation	Conduction AVG Power(dBm)	Ant Gain (dBi)	ERP (dBm)	ERP Limit(W)	ERP Limit(dBm)	Verdict
10	Middle	1	0	QPSK	24.13	-0.43	21.55	100.00	50.00	PASS
		1	24		24.10	-0.43	21.52	100.00	50.00	PASS
		1	49		24.13	-0.43	21.55	100.00	50.00	PASS
		25	0		21.98	-0.43	19.40	100.00	50.00	PASS
		25	12		21.84	-0.43	19.26	100.00	50.00	PASS
		25	24		21.93	-0.43	19.35	100.00	50.00	PASS
		50	0		21.87	-0.43	19.29	100.00	50.00	PASS
		1	0	16QAM	23.13	-0.43	20.55	100.00	50.00	PASS
		1	24		23.13	-0.43	20.55	100.00	50.00	PASS
		1	49		23.20	-0.43	20.62	100.00	50.00	PASS
		25	0		21.84	-0.43	19.26	100.00	50.00	PASS
		25	12		21.93	-0.43	19.35	100.00	50.00	PASS
		25	24		21.96	-0.43	19.38	100.00	50.00	PASS
		50	0		21.86	-0.43	19.28	100.00	50.00	PASS



Radiated Power (EIRP) for LTE Band 41 /5M										
BW (MHz)	UL Channel	RB Size	RB offset	Modulation	Conduction AVG Power(dBm)	Ant Gain (dBi)	EIRP (dBm)	EIRP Limit(W)	EIRP Limit(dBm)	Verdict
5	Lowest	1	0	QPSK	22.92	-0.15	22.77	2.00	33.01	PASS
		1	12		22.88	-0.15	22.73	2.00	33.01	PASS
		1	24		22.69	-0.15	22.54	2.00	33.01	PASS
		12	0		21.91	-0.15	21.76	2.00	33.01	PASS
		12	6		21.99	-0.15	21.84	2.00	33.01	PASS
		12	11		21.89	-0.15	21.74	2.00	33.01	PASS
		25	0		21.94	-0.15	21.79	2.00	33.01	PASS
		1	0	16QAM	23.16	-0.15	23.01	2.00	33.01	PASS
		1	12		22.84	-0.15	22.69	2.00	33.01	PASS
		1	24		22.58	-0.15	22.43	2.00	33.01	PASS
		12	0		20.85	-0.15	20.70	2.00	33.01	PASS
		12	6		21.13	-0.15	20.98	2.00	33.01	PASS
		12	11		21.03	-0.15	20.88	2.00	33.01	PASS
		25	0		21.10	-0.15	20.95	2.00	33.01	PASS
	Middle	QPSK	1	0	23.00	-0.15	22.85	2.00	33.01	PASS
			1	12	23.05	-0.15	22.90	2.00	33.01	PASS
			1	24	23.11	-0.15	22.96	2.00	33.01	PASS
			12	0	21.99	-0.15	21.84	2.00	33.01	PASS
			12	6	22.00	-0.15	21.85	2.00	33.01	PASS
			12	11	21.94	-0.15	21.79	2.00	33.01	PASS
			25	0	21.98	-0.15	21.83	2.00	33.01	PASS
		16QAM	1	0	22.61	-0.15	22.46	2.00	33.01	PASS
			1	12	22.71	-0.15	22.56	2.00	33.01	PASS
			1	24	22.07	-0.15	21.92	2.00	33.01	PASS
			12	0	21.06	-0.15	20.91	2.00	33.01	PASS
			12	6	21.08	-0.15	20.93	2.00	33.01	PASS
			12	11	21.01	-0.15	20.86	2.00	33.01	PASS
			25	0	20.93	-0.15	20.78	2.00	33.01	PASS
	Highest	QPSK	1	0	22.70	-0.15	22.55	2.00	33.01	PASS
			1	12	22.76	-0.15	22.61	2.00	33.01	PASS
			1	24	23.13	-0.15	22.98	2.00	33.01	PASS
			12	0	21.89	-0.15	21.74	2.00	33.01	PASS
			12	6	21.90	-0.15	21.75	2.00	33.01	PASS
			12	11	21.92	-0.15	21.77	2.00	33.01	PASS
			25	0	21.78	-0.15	21.63	2.00	33.01	PASS
		16QAM	1	0	22.08	-0.15	21.93	2.00	33.01	PASS
			1	12	22.27	-0.15	22.12	2.00	33.01	PASS
			1	24	22.26	-0.15	22.11	2.00	33.01	PASS
			12	0	20.97	-0.15	20.82	2.00	33.01	PASS
			12	6	20.99	-0.15	20.84	2.00	33.01	PASS
			12	11	20.96	-0.15	20.81	2.00	33.01	PASS
			25	0	21.02	-0.15	20.87	2.00	33.01	PASS



Radiated Power (EIRP) for LTE Band 41 /10M										
BW (MHz)	UL Channel	RB Size	RB offset	Modulation	Conduction AVG Power(dBm)	Ant Gain (dBi)	EIRP (dBm)	EIRP Limit(W)	EIRP Limit(dBm)	Verdict
10	Lowest	1	0	QPSK	22.88	-0.15	22.73	2.00	33.01	PASS
		1	24		22.79	-0.15	22.64	2.00	33.01	PASS
		1	49		22.87	-0.15	22.72	2.00	33.01	PASS
		25	0		21.94	-0.15	21.79	2.00	33.01	PASS
		25	12		21.96	-0.15	21.81	2.00	33.01	PASS
		25	24		21.90	-0.15	21.75	2.00	33.01	PASS
		50	0	21.66	-0.15	21.51	2.00	33.01	PASS	
		1	0	16QAM	22.62	-0.15	22.47	2.00	33.01	PASS
		1	24		22.65	-0.15	22.50	2.00	33.01	PASS
		1	49		22.71	-0.15	22.56	2.00	33.01	PASS
		25	0		21.16	-0.15	21.01	2.00	33.01	PASS
		25	12		21.23	-0.15	21.08	2.00	33.01	PASS
		25	24		21.20	-0.15	21.05	2.00	33.01	PASS
		50	0	20.74	-0.15	20.59	2.00	33.01	PASS	
		1	0	QPSK	22.93	-0.15	22.78	2.00	33.01	PASS
	1	24	22.95		-0.15	22.80	2.00	33.01	PASS	
	1	49	22.83		-0.15	22.68	2.00	33.01	PASS	
	25	0	22.00		-0.15	21.85	2.00	33.01	PASS	
	25	12	21.95		-0.15	21.80	2.00	33.01	PASS	
	25	24	21.92		-0.15	21.77	2.00	33.01	PASS	
	50	0	21.51	-0.15	21.36	2.00	33.01	PASS		
	1	0	16QAM	22.49	-0.15	22.34	2.00	33.01	PASS	
	1	24		22.55	-0.15	22.40	2.00	33.01	PASS	
	1	49		22.77	-0.15	22.62	2.00	33.01	PASS	
	25	0		21.04	-0.15	20.89	2.00	33.01	PASS	
	25	12		21.09	-0.15	20.94	2.00	33.01	PASS	
	25	24		21.07	-0.15	20.92	2.00	33.01	PASS	
	50	0	20.67	-0.15	20.52	2.00	33.01	PASS		
	1	0	QPSK	22.75	-0.15	22.60	2.00	33.01	PASS	
	1	24		22.68	-0.15	22.53	2.00	33.01	PASS	
	1	49		22.77	-0.15	22.62	2.00	33.01	PASS	
	25	0		21.85	-0.15	21.70	2.00	33.01	PASS	
	25	12		21.83	-0.15	21.68	2.00	33.01	PASS	
	25	24		21.78	-0.15	21.63	2.00	33.01	PASS	
	50	0	21.49	-0.15	21.34	2.00	33.01	PASS		
	1	0	16QAM	22.34	-0.15	22.19	2.00	33.01	PASS	
	1	24		22.90	-0.15	22.75	2.00	33.01	PASS	
	1	49		22.92	-0.15	22.77	2.00	33.01	PASS	
	25	0		21.08	-0.15	20.93	2.00	33.01	PASS	
	25	12		21.07	-0.15	20.92	2.00	33.01	PASS	
	25	24		20.98	-0.15	20.83	2.00	33.01	PASS	
	50	0	20.67	-0.15	20.52	2.00	33.01	PASS		



Radiated Power (EIRP) for LTE Band 41 /15M										
BW (MHz)	UL Channel	RB Size	RB offset	Modulation	Conduction AVG Power(dBm)	Ant Gain (dBi)	EIRP (dBm)	EIRP Limit(W)	EIRP Limit(dBm)	Verdict
15	Lowest	1	0	QPSK	22.94	-0.15	22.79	2.00	33.01	PASS
		1	37		22.84	-0.15	22.69	2.00	33.01	PASS
		1	74		22.87	-0.15	22.72	2.00	33.01	PASS
		36	0		22.03	-0.15	21.88	2.00	33.01	PASS
		36	18		21.89	-0.15	21.74	2.00	33.01	PASS
		36	39		22.00	-0.15	21.85	2.00	33.01	PASS
		75	0		21.67	-0.15	21.52	2.00	33.01	PASS
		1	0	16QAM	22.51	-0.15	22.36	2.00	33.01	PASS
		1	37		22.51	-0.15	22.36	2.00	33.01	PASS
		1	74		22.61	-0.15	22.46	2.00	33.01	PASS
		36	0		21.07	-0.15	20.92	2.00	33.01	PASS
		36	18		21.08	-0.15	20.93	2.00	33.01	PASS
		36	39		21.05	-0.15	20.90	2.00	33.01	PASS
		75	0		20.69	-0.15	20.54	2.00	33.01	PASS
	Middle	QPSK	1	0	22.84	-0.15	22.69	2.00	33.01	PASS
			1	37	22.84	-0.15	22.69	2.00	33.01	PASS
			1	74	22.81	-0.15	22.66	2.00	33.01	PASS
			36	0	21.93	-0.15	21.78	2.00	33.01	PASS
			36	18	21.89	-0.15	21.74	2.00	33.01	PASS
			36	39	21.88	-0.15	21.73	2.00	33.01	PASS
			75	0	21.54	-0.15	21.39	2.00	33.01	PASS
		16QAM	1	0	22.84	-0.15	22.69	2.00	33.01	PASS
			1	37	22.96	-0.15	22.81	2.00	33.01	PASS
			1	74	22.90	-0.15	22.75	2.00	33.01	PASS
			36	0	21.14	-0.15	20.99	2.00	33.01	PASS
			36	18	21.14	-0.15	20.99	2.00	33.01	PASS
			36	39	21.10	-0.15	20.95	2.00	33.01	PASS
			75	0	20.71	-0.15	20.56	2.00	33.01	PASS
	Highest	QPSK	1	0	22.72	-0.15	22.57	2.00	33.01	PASS
			1	37	22.79	-0.15	22.64	2.00	33.01	PASS
			1	74	22.86	-0.15	22.71	2.00	33.01	PASS
			36	0	21.92	-0.15	21.77	2.00	33.01	PASS
			36	18	21.89	-0.15	21.74	2.00	33.01	PASS
			36	39	21.81	-0.15	21.66	2.00	33.01	PASS
			75	0	21.40	-0.15	21.25	2.00	33.01	PASS
		16QAM	1	0	22.68	-0.15	22.53	2.00	33.01	PASS
			1	37	22.68	-0.15	22.53	2.00	33.01	PASS
			1	74	22.75	-0.15	22.60	2.00	33.01	PASS
			36	0	20.98	-0.15	20.83	2.00	33.01	PASS
			36	18	21.03	-0.15	20.88	2.00	33.01	PASS
			36	39	21.00	-0.15	20.85	2.00	33.01	PASS
			75	0	20.63	-0.15	20.48	2.00	33.01	PASS



Radiated Power (EIRP) for LTE Band 41 /20M										
BW (MHz)	UL Channel	RB Size	RB offset	Modulation	Conduction AVG Power(dBm)	Ant Gain (dBi)	EIRP (dBm)	EIRP Limit(W)	EIRP Limit(dBm)	Verdict
20	Lowest	1	0	QPSK	22.75	-0.15	22.60	2.00	33.01	PASS
		1	49		22.76	-0.15	22.61	2.00	33.01	PASS
		1	99		23.03	-0.15	22.88	2.00	33.01	PASS
		50	0		21.90	-0.15	21.75	2.00	33.01	PASS
		50	24		21.82	-0.15	21.67	2.00	33.01	PASS
		50	49		21.97	-0.15	21.82	2.00	33.01	PASS
		100	0	21.67	-0.15	21.52	2.00	33.01	PASS	
		1	0	16QAM	23.10	-0.15	22.95	2.00	33.01	PASS
		1	49		23.13	-0.15	22.98	2.00	33.01	PASS
		1	99		23.32	-0.15	23.17	2.00	33.01	PASS
		50	0		21.11	-0.15	20.96	2.00	33.01	PASS
		50	24		21.17	-0.15	21.02	2.00	33.01	PASS
		50	49		21.22	-0.15	21.07	2.00	33.01	PASS
		100	0	21.12	-0.15	20.97	2.00	33.01	PASS	
		1	0	QPSK	23.13	-0.15	22.98	2.00	33.01	PASS
		1	49		23.11	-0.15	22.96	2.00	33.01	PASS
	1	99	23.11		-0.15	22.96	2.00	33.01	PASS	
	50	0	21.94		-0.15	21.79	2.00	33.01	PASS	
	50	24	21.92		-0.15	21.77	2.00	33.01	PASS	
	50	49	21.98		-0.15	21.83	2.00	33.01	PASS	
	100	0	21.60	-0.15	21.45	2.00	33.01	PASS		
	1	0	16QAM	23.24	-0.15	23.09	2.00	33.01	PASS	
	1	49		23.16	-0.15	23.01	2.00	33.01	PASS	
	1	99		23.17	-0.15	23.02	2.00	33.01	PASS	
	50	0		21.17	-0.15	21.02	2.00	33.01	PASS	
	50	24		21.17	-0.15	21.02	2.00	33.01	PASS	
	50	49		21.09	-0.15	20.94	2.00	33.01	PASS	
	100	0	21.02	-0.15	20.87	2.00	33.01	PASS		
	1	0	QPSK	22.85	-0.15	22.70	2.00	33.01	PASS	
	1	49		22.81	-0.15	22.66	2.00	33.01	PASS	
	1	99		22.87	-0.15	22.72	2.00	33.01	PASS	
	50	0		21.84	-0.15	21.69	2.00	33.01	PASS	
	50	24		21.88	-0.15	21.73	2.00	33.01	PASS	
	50	49		21.81	-0.15	21.66	2.00	33.01	PASS	
	100	0	21.51	-0.15	21.36	2.00	33.01	PASS		
	1	0	16QAM	22.35	-0.15	22.20	2.00	33.01	PASS	
	1	49		22.29	-0.15	22.14	2.00	33.01	PASS	
	1	99		22.21	-0.15	22.06	2.00	33.01	PASS	
	50	0		21.00	-0.15	20.85	2.00	33.01	PASS	
	50	24		20.98	-0.15	20.83	2.00	33.01	PASS	
	50	49		20.97	-0.15	20.82	2.00	33.01	PASS	
	100	0	21.01	-0.15	20.86	2.00	33.01	PASS		



Radiated Power (EIRP) for LTE Band 66 /1.4M										
BW (MHz)	UL Channel	RB Size	RB offset	Modulation	Conduction AVG Power(dBm)	Ant Gain (dBi)	EIRP (dBm)	EIRP Limit(W)	EIRP Limit(dBm)	Verdict
1.4	Lowest	1	0	QPSK	24.15	-0.29	23.86	1.00	30.00	PASS
		1	2		24.06	-0.29	23.77	1.00	30.00	PASS
		1	5		24.10	-0.29	23.81	1.00	30.00	PASS
		3	0		23.87	-0.29	23.58	1.00	30.00	PASS
		3	1		23.83	-0.29	23.54	1.00	30.00	PASS
		3	2		23.81	-0.29	23.52	1.00	30.00	PASS
		6	0	22.78	-0.29	22.49	1.00	30.00	PASS	
		1	0	16QAM	23.12	-0.29	22.83	1.00	30.00	PASS
		1	2		23.20	-0.29	22.91	1.00	30.00	PASS
		1	5		23.22	-0.29	22.93	1.00	30.00	PASS
		3	0		22.93	-0.29	22.64	1.00	30.00	PASS
		3	1		23.00	-0.29	22.71	1.00	30.00	PASS
		3	2		22.90	-0.29	22.61	1.00	30.00	PASS
		6	0	21.89	-0.29	21.60	1.00	30.00	PASS	
	Middle	QPSK	1	0	24.04	-0.29	23.75	1.00	30.00	PASS
			1	2	24.08	-0.29	23.79	1.00	30.00	PASS
			1	5	23.98	-0.29	23.69	1.00	30.00	PASS
			3	0	23.90	-0.29	23.61	1.00	30.00	PASS
			3	1	23.94	-0.29	23.65	1.00	30.00	PASS
			3	2	23.92	-0.29	23.63	1.00	30.00	PASS
		6	0	22.92	-0.29	22.63	1.00	30.00	PASS	
		16QAM	1	0	23.21	-0.29	22.92	1.00	30.00	PASS
			1	2	23.19	-0.29	22.90	1.00	30.00	PASS
			1	5	24.00	-0.29	23.71	1.00	30.00	PASS
			3	0	23.03	-0.29	22.74	1.00	30.00	PASS
			3	1	23.01	-0.29	22.72	1.00	30.00	PASS
			3	2	22.82	-0.29	22.53	1.00	30.00	PASS
			6	0	21.94	-0.29	21.65	1.00	30.00	PASS
	Highest		QPSK	1	0	23.92	-0.29	23.63	1.00	30.00
		1		2	23.86	-0.29	23.57	1.00	30.00	PASS
		1		5	24.17	-0.29	23.88	1.00	30.00	PASS
		3		0	23.86	-0.29	23.57	1.00	30.00	PASS
		3		1	23.86	-0.29	23.57	1.00	30.00	PASS
		3		2	23.86	-0.29	23.57	1.00	30.00	PASS
		6	0	22.83	-0.29	22.54	1.00	30.00	PASS	
		16QAM	1	0	23.62	-0.29	23.33	1.00	30.00	PASS
1			2	23.59	-0.29	23.30	1.00	30.00	PASS	
1			5	23.61	-0.29	23.32	1.00	30.00	PASS	
3			0	22.98	-0.29	22.69	1.00	30.00	PASS	
3			1	23.01	-0.29	22.72	1.00	30.00	PASS	
3			2	22.93	-0.29	22.64	1.00	30.00	PASS	
6			0	22.10	-0.29	21.81	1.00	30.00	PASS	



Radiated Power (EIRP) for LTE Band 66 /3M											
BW (MHz)	UL Channel	RB Size	RB offset	Modulation	Conduction AVG Power(dBm)	Ant Gain (dBi)	EIRP (dBm)	EIRP Limit(W)	EIRP Limit(dBm)	Verdict	
3	Lowest	1	0	QPSK	24.12	-0.29	23.83	1.00	30.00	PASS	
		1	7		24.08	-0.29	23.79	1.00	30.00	PASS	
		1	14		24.07	-0.29	23.78	1.00	30.00	PASS	
		8	0		22.73	-0.29	22.44	1.00	30.00	PASS	
		8	4		22.76	-0.29	22.47	1.00	30.00	PASS	
		8	7		22.82	-0.29	22.53	1.00	30.00	PASS	
		15	0	22.79	-0.29	22.50	1.00	30.00	PASS		
		1	0	22.59	-0.29	22.30	1.00	30.00	PASS		
		1	7	22.61	-0.29	22.32	1.00	30.00	PASS		
		1	14	22.67	-0.29	22.38	1.00	30.00	PASS		
		8	0	21.72	-0.29	21.43	1.00	30.00	PASS		
		8	4	21.72	-0.29	21.43	1.00	30.00	PASS		
		8	7	21.80	-0.29	21.51	1.00	30.00	PASS		
		15	0	21.83	-0.29	21.54	1.00	30.00	PASS		
		Middle	QPSK	1	0	23.66	-0.29	23.37	1.00	30.00	PASS
	1			7	23.63	-0.29	23.34	1.00	30.00	PASS	
	1			14	23.57	-0.29	23.28	1.00	30.00	PASS	
	8			0	22.87	-0.29	22.58	1.00	30.00	PASS	
	8			4	22.86	-0.29	22.57	1.00	30.00	PASS	
	8			7	22.86	-0.29	22.57	1.00	30.00	PASS	
	15		0	22.97	-0.29	22.68	1.00	30.00	PASS		
	16QAM		1	0	23.01	-0.29	22.72	1.00	30.00	PASS	
			1	7	23.15	-0.29	22.86	1.00	30.00	PASS	
			1	14	23.33	-0.29	23.04	1.00	30.00	PASS	
			8	0	21.88	-0.29	21.59	1.00	30.00	PASS	
			8	4	21.95	-0.29	21.66	1.00	30.00	PASS	
			8	7	21.88	-0.29	21.59	1.00	30.00	PASS	
			15	0	21.97	-0.29	21.68	1.00	30.00	PASS	
			Highest	QPSK	1	0	24.14	-0.29	23.85	1.00	30.00
		1			7	24.22	-0.29	23.93	1.00	30.00	PASS
	1	14			24.17	-0.29	23.88	1.00	30.00	PASS	
	8	0			22.88	-0.29	22.59	1.00	30.00	PASS	
	8	4			22.91	-0.29	22.62	1.00	30.00	PASS	
	8	7			22.88	-0.29	22.59	1.00	30.00	PASS	
	15	0		22.97	-0.29	22.68	1.00	30.00	PASS		
	16QAM	1		0	23.23	-0.29	22.94	1.00	30.00	PASS	
1		7		23.05	-0.29	22.76	1.00	30.00	PASS		
1		14		23.00	-0.29	22.71	1.00	30.00	PASS		
8		0		22.04	-0.29	21.75	1.00	30.00	PASS		
8		4		21.93	-0.29	21.64	1.00	30.00	PASS		
8		7		22.03	-0.29	21.74	1.00	30.00	PASS		
15		0		22.11	-0.29	21.82	1.00	30.00	PASS		



Radiated Power (EIRP) for LTE Band 66 /5M										
BW (MHz)	UL Channel	RB Size	RB offset	Modulation	Conduction AVG Power(dBm)	Ant Gain (dBi)	EIRP (dBm)	EIRP Limit(W)	EIRP Limit(dBm)	Verdict
5	Lowest	1	0	QPSK	23.72	-0.29	23.43	1.00	30.00	PASS
		1	12		23.71	-0.29	23.42	1.00	30.00	PASS
		1	24		23.66	-0.29	23.37	1.00	30.00	PASS
		12	0		22.78	-0.29	22.49	1.00	30.00	PASS
		12	6		22.87	-0.29	22.58	1.00	30.00	PASS
		12	11		22.69	-0.29	22.40	1.00	30.00	PASS
		25	0	22.80	-0.29	22.51	1.00	30.00	PASS	
		1	0	16QAM	23.22	-0.29	22.93	1.00	30.00	PASS
		1	12		23.26	-0.29	22.97	1.00	30.00	PASS
		1	24		23.17	-0.29	22.88	1.00	30.00	PASS
		12	0		21.72	-0.29	21.43	1.00	30.00	PASS
		12	6		21.78	-0.29	21.49	1.00	30.00	PASS
		12	11		21.80	-0.29	21.51	1.00	30.00	PASS
		25	0	21.95	-0.29	21.66	1.00	30.00	PASS	
		1	0	QPSK	24.01	-0.29	23.72	1.00	30.00	PASS
	1	12	24.07		-0.29	23.78	1.00	30.00	PASS	
	1	24	23.96		-0.29	23.67	1.00	30.00	PASS	
	12	0	22.77		-0.29	22.48	1.00	30.00	PASS	
	12	6	22.93		-0.29	22.64	1.00	30.00	PASS	
	12	11	22.77		-0.29	22.48	1.00	30.00	PASS	
	25	0	22.91	-0.29	22.62	1.00	30.00	PASS		
	1	0	16QAM	23.11	-0.29	22.82	1.00	30.00	PASS	
	1	12		23.10	-0.29	22.81	1.00	30.00	PASS	
	1	24		22.94	-0.29	22.65	1.00	30.00	PASS	
	12	0		21.78	-0.29	21.49	1.00	30.00	PASS	
	12	6		21.97	-0.29	21.68	1.00	30.00	PASS	
	12	11		21.92	-0.29	21.63	1.00	30.00	PASS	
	25	0	21.90	-0.29	21.61	1.00	30.00	PASS		
	1	0	QPSK	23.95	-0.29	23.66	1.00	30.00	PASS	
	1	12		23.79	-0.29	23.50	1.00	30.00	PASS	
	1	24		23.80	-0.29	23.51	1.00	30.00	PASS	
	12	0		22.92	-0.29	22.63	1.00	30.00	PASS	
	12	6		22.84	-0.29	22.55	1.00	30.00	PASS	
	12	11		22.96	-0.29	22.67	1.00	30.00	PASS	
	25	0	22.90	-0.29	22.61	1.00	30.00	PASS		
	1	0	16QAM	22.51	-0.29	22.22	1.00	30.00	PASS	
	1	12		22.53	-0.29	22.24	1.00	30.00	PASS	
	1	24		22.95	-0.29	22.66	1.00	30.00	PASS	
	12	0		22.01	-0.29	21.72	1.00	30.00	PASS	
	12	6		22.01	-0.29	21.72	1.00	30.00	PASS	
	12	11		22.01	-0.29	21.72	1.00	30.00	PASS	
	25	0	21.85	-0.29	21.56	1.00	30.00	PASS		



Radiated Power (EIRP) for LTE Band 66 /10M										
BW (MHz)	UL Channel	RB Size	RB offset	Modulation	Conduction AVG Power(dBm)	Ant Gain (dBi)	EIRP (dBm)	EIRP Limit(W)	EIRP Limit(dBm)	Verdict
10	Lowest	1	0	QPSK	21.69	-0.29	21.40	1.00	30.00	PASS
		1	24		22.35	-0.29	22.06	1.00	30.00	PASS
		1	49		21.66	-0.29	21.37	1.00	30.00	PASS
		25	0		21.82	-0.29	21.53	1.00	30.00	PASS
		25	12		24.25	-0.29	23.96	1.00	30.00	PASS
		25	24		23.78	-0.29	23.49	1.00	30.00	PASS
		50	0	23.46	-0.29	23.17	1.00	30.00	PASS	
		1	0	16QAM	22.80	-0.29	22.51	1.00	30.00	PASS
		1	24		23.28	-0.29	22.99	1.00	30.00	PASS
		1	49		23.32	-0.29	23.03	1.00	30.00	PASS
		25	0		22.02	-0.29	21.73	1.00	30.00	PASS
		25	12		21.92	-0.29	21.63	1.00	30.00	PASS
		25	24		22.00	-0.29	21.71	1.00	30.00	PASS
		50	0	21.91	-0.29	21.62	1.00	30.00	PASS	
		1	0	QPSK	24.00	-0.29	23.71	1.00	30.00	PASS
	1	24	24.09		-0.29	23.80	1.00	30.00	PASS	
	1	49	23.92		-0.29	23.63	1.00	30.00	PASS	
	25	0	22.75		-0.29	22.46	1.00	30.00	PASS	
	25	12	22.87		-0.29	22.58	1.00	30.00	PASS	
	25	24	22.79		-0.29	22.50	1.00	30.00	PASS	
	50	0	22.93	-0.29	22.64	1.00	30.00	PASS		
	1	0	16QAM	23.23	-0.29	22.94	1.00	30.00	PASS	
	1	24		23.28	-0.29	22.99	1.00	30.00	PASS	
	1	49		23.27	-0.29	22.98	1.00	30.00	PASS	
	25	0		21.94	-0.29	21.65	1.00	30.00	PASS	
	25	12		22.04	-0.29	21.75	1.00	30.00	PASS	
	25	24		21.97	-0.29	21.68	1.00	30.00	PASS	
	50	0	22.07	-0.29	21.78	1.00	30.00	PASS		
	1	0	QPSK	23.86	-0.29	23.57	1.00	30.00	PASS	
	1	24		23.89	-0.29	23.60	1.00	30.00	PASS	
	1	49		23.98	-0.29	23.69	1.00	30.00	PASS	
	25	0		22.92	-0.29	22.63	1.00	30.00	PASS	
	25	12		22.83	-0.29	22.54	1.00	30.00	PASS	
	25	24		22.85	-0.29	22.56	1.00	30.00	PASS	
	50	0	22.84	-0.29	22.55	1.00	30.00	PASS		
	1	0	16QAM	23.32	-0.29	23.03	1.00	30.00	PASS	
	1	24		23.35	-0.29	23.06	1.00	30.00	PASS	
	1	49		23.37	-0.29	23.08	1.00	30.00	PASS	
	25	0		22.05	-0.29	21.76	1.00	30.00	PASS	
	25	12		22.08	-0.29	21.79	1.00	30.00	PASS	
	25	24		22.11	-0.29	21.82	1.00	30.00	PASS	
	50	0	22.10	-0.29	21.81	1.00	30.00	PASS		



Radiated Power (EIRP) for LTE Band 66 /15M										
BW (MHz)	UL Channel	RB Size	RB offset	Modulation	Conduction AVG Power(dBm)	Ant Gain (dBi)	EIRP (dBm)	EIRP Limit(W)	EIRP Limit(dBm)	Verdict
15	Lowest	1	0	QPSK	24.06	-0.29	23.77	1.00	30.00	PASS
		1	37		24.00	-0.29	23.71	1.00	30.00	PASS
		1	74		24.19	-0.29	23.90	1.00	30.00	PASS
		36	0		22.73	-0.29	22.44	1.00	30.00	PASS
		36	18		22.70	-0.29	22.41	1.00	30.00	PASS
		36	39		22.80	-0.29	22.51	1.00	30.00	PASS
		75	0	22.70	-0.29	22.41	1.00	30.00	PASS	
		1	0	16QAM	22.59	-0.29	22.30	1.00	30.00	PASS
		1	37		22.54	-0.29	22.25	1.00	30.00	PASS
		1	74		22.56	-0.29	22.27	1.00	30.00	PASS
		36	0		21.86	-0.29	21.57	1.00	30.00	PASS
		36	18		21.83	-0.29	21.54	1.00	30.00	PASS
		36	39		21.88	-0.29	21.59	1.00	30.00	PASS
		75	0	21.91	-0.29	21.62	1.00	30.00	PASS	
	Middle	QPSK	1	0	23.61	-0.29	23.32	1.00	30.00	PASS
			1	37	23.76	-0.29	23.47	1.00	30.00	PASS
			1	74	23.65	-0.29	23.36	1.00	30.00	PASS
			36	0	22.75	-0.29	22.46	1.00	30.00	PASS
			36	18	22.88	-0.29	22.59	1.00	30.00	PASS
			36	39	22.81	-0.29	22.52	1.00	30.00	PASS
		75	0	22.87	-0.29	22.58	1.00	30.00	PASS	
		16QAM	1	0	23.46	-0.29	23.17	1.00	30.00	PASS
			1	37	23.64	-0.29	23.35	1.00	30.00	PASS
			1	74	23.45	-0.29	23.16	1.00	30.00	PASS
			36	0	21.98	-0.29	21.69	1.00	30.00	PASS
			36	18	22.02	-0.29	21.73	1.00	30.00	PASS
			36	39	21.92	-0.29	21.63	1.00	30.00	PASS
		75	0	21.99	-0.29	21.70	1.00	30.00	PASS	
	Highest	QPSK	1	0	23.96	-0.29	23.67	1.00	30.00	PASS
			1	37	24.07	-0.29	23.78	1.00	30.00	PASS
			1	74	24.19	-0.29	23.90	1.00	30.00	PASS
			36	0	22.82	-0.29	22.53	1.00	30.00	PASS
			36	18	22.85	-0.29	22.56	1.00	30.00	PASS
			36	39	22.88	-0.29	22.59	1.00	30.00	PASS
		75	0	22.81	-0.29	22.52	1.00	30.00	PASS	
		16QAM	1	0	22.83	-0.29	22.54	1.00	30.00	PASS
1			37	23.09	-0.29	22.80	1.00	30.00	PASS	
1			74	23.26	-0.29	22.97	1.00	30.00	PASS	
36			0	21.90	-0.29	21.61	1.00	30.00	PASS	
36			18	21.95	-0.29	21.66	1.00	30.00	PASS	
36			39	21.98	-0.29	21.69	1.00	30.00	PASS	
75		0	22.00	-0.29	21.71	1.00	30.00	PASS		



Radiated Power (EIRP) for LTE Band 66 /20M										
BW (MHz)	UL Channel	RB Size	RB offset	Modulation	Conduction AVG Power(dBm)	Ant Gain (dBi)	EIRP (dBm)	EIRP Limit(W)	EIRP Limit(dBm)	Verdict
20	Lowest	1	0	QPSK	22.00	-0.29	21.71	1.00	30.00	PASS
		1	49		24.07	-0.29	23.78	1.00	30.00	PASS
		1	99		23.94	-0.29	23.65	1.00	30.00	PASS
		50	0		24.07	-0.29	23.78	1.00	30.00	PASS
		50	24		22.84	-0.29	22.55	1.00	30.00	PASS
		50	49		22.75	-0.29	22.46	1.00	30.00	PASS
		100	0	22.82	-0.29	22.53	1.00	30.00	PASS	
		1	0	16QAM	22.74	-0.29	22.45	1.00	30.00	PASS
		1	49		23.06	-0.29	22.77	1.00	30.00	PASS
		1	99		23.00	-0.29	22.71	1.00	30.00	PASS
		50	0		23.15	-0.29	22.86	1.00	30.00	PASS
		50	24		21.94	-0.29	21.65	1.00	30.00	PASS
		50	49		21.94	-0.29	21.65	1.00	30.00	PASS
		100	0	22.00	-0.29	21.71	1.00	30.00	PASS	
		1	0	QPSK	21.84	-0.29	21.55	1.00	30.00	PASS
	1	49	23.95		-0.29	23.66	1.00	30.00	PASS	
	1	99	23.99		-0.29	23.70	1.00	30.00	PASS	
	50	0	23.84		-0.29	23.55	1.00	30.00	PASS	
	50	24	22.80		-0.29	22.51	1.00	30.00	PASS	
	50	49	22.91		-0.29	22.62	1.00	30.00	PASS	
	100	0	22.81	-0.29	22.52	1.00	30.00	PASS		
	1	0	16QAM	22.90	-0.29	22.61	1.00	30.00	PASS	
	1	49		23.18	-0.29	22.89	1.00	30.00	PASS	
	1	99		23.29	-0.29	23.00	1.00	30.00	PASS	
	50	0		23.15	-0.29	22.86	1.00	30.00	PASS	
	50	24		21.94	-0.29	21.65	1.00	30.00	PASS	
	50	49		22.08	-0.29	21.79	1.00	30.00	PASS	
	100	0	21.99	-0.29	21.70	1.00	30.00	PASS		
	1	0	QPSK	21.99	-0.29	21.70	1.00	30.00	PASS	
	1	49		23.86	-0.29	23.57	1.00	30.00	PASS	
	1	99		23.98	-0.29	23.69	1.00	30.00	PASS	
	50	0		24.31	-0.29	24.02	1.00	30.00	PASS	
	50	24		22.87	-0.29	22.58	1.00	30.00	PASS	
	50	49		22.76	-0.29	22.47	1.00	30.00	PASS	
	100	0	22.85	-0.29	22.56	1.00	30.00	PASS		
	1	0	16QAM	22.82	-0.29	22.53	1.00	30.00	PASS	
	1	49		22.97	-0.29	22.68	1.00	30.00	PASS	
	1	99		22.88	-0.29	22.59	1.00	30.00	PASS	
	50	0		22.92	-0.29	22.63	1.00	30.00	PASS	
	50	24		21.88	-0.29	21.59	1.00	30.00	PASS	
	50	49		21.91	-0.29	21.62	1.00	30.00	PASS	
	100	0	22.01	-0.29	21.72	1.00	30.00	PASS		



Radiated Power (ERP) for LTE Band 71 /5M										
BW (MHz)	UL Channel	RB Size	RB offset	Modulation	Conduction AVG Power(dBm)	Ant Gain (dBi)	ERP (dBm)	ERP Limit(W)	ERP Limit(dBm)	Verdict
5	Lowest	1	0	QPSK	22.61	-0.72	19.74	3.00	34.77	PASS
		1	12		22.57	-0.72	19.70	3.00	34.77	PASS
		1	24		22.96	-0.72	20.09	3.00	34.77	PASS
		12	0		21.93	-0.72	19.06	3.00	34.77	PASS
		12	6		21.94	-0.72	19.07	3.00	34.77	PASS
		12	11		21.99	-0.72	19.12	3.00	34.77	PASS
		25	0		22.04	-0.72	19.17	3.00	34.77	PASS
		1	0	16QAM	22.56	-0.72	19.69	3.00	34.77	PASS
		1	12		22.67	-0.72	19.80	3.00	34.77	PASS
		1	24		22.66	-0.72	19.79	3.00	34.77	PASS
		12	0		20.91	-0.72	18.04	3.00	34.77	PASS
		12	6		20.84	-0.72	17.97	3.00	34.77	PASS
		12	11		21.01	-0.72	18.14	3.00	34.77	PASS
		25	0		20.96	-0.72	18.09	3.00	34.77	PASS
	Middle	QPSK	1	0	22.35	-0.72	19.48	3.00	34.77	PASS
			1	12	22.21	-0.72	19.34	3.00	34.77	PASS
			1	24	22.22	-0.72	19.35	3.00	34.77	PASS
			12	0	21.93	-0.72	19.06	3.00	34.77	PASS
			12	6	21.83	-0.72	18.96	3.00	34.77	PASS
			12	11	22.03	-0.72	19.16	3.00	34.77	PASS
			25	0	21.93	-0.72	19.06	3.00	34.77	PASS
		16QAM	1	0	21.37	-0.72	18.50	3.00	34.77	PASS
			1	12	21.91	-0.72	19.04	3.00	34.77	PASS
			1	24	21.95	-0.72	19.08	3.00	34.77	PASS
			12	0	20.91	-0.72	18.04	3.00	34.77	PASS
			12	6	20.86	-0.72	17.99	3.00	34.77	PASS
			12	11	20.89	-0.72	18.02	3.00	34.77	PASS
			25	0	20.80	-0.72	17.93	3.00	34.77	PASS
	Highest	QPSK	1	0	22.34	-0.72	19.47	3.00	34.77	PASS
			1	12	22.21	-0.72	19.34	3.00	34.77	PASS
			1	24	22.18	-0.72	19.31	3.00	34.77	PASS
			12	0	21.22	-0.72	18.35	3.00	34.77	PASS
			12	6	21.28	-0.72	18.41	3.00	34.77	PASS
			12	11	21.20	-0.72	18.33	3.00	34.77	PASS
			25	0	21.26	-0.72	18.39	3.00	34.77	PASS
		16QAM	1	0	21.83	-0.72	18.96	3.00	34.77	PASS
1			12	21.70	-0.72	18.83	3.00	34.77	PASS	
1			24	22.11	-0.72	19.24	3.00	34.77	PASS	
12			0	20.11	-0.72	17.24	3.00	34.77	PASS	
12			6	20.78	-0.72	17.91	3.00	34.77	PASS	
12			11	20.78	-0.72	17.91	3.00	34.77	PASS	
25			0	20.87	-0.72	18.00	3.00	34.77	PASS	



Radiated Power (ERP) for LTE Band 71 /10M										
BW (MHz)	UL Channel	RB Size	RB offset	Modulation	Conduction AVG Power(dBm)	Ant Gain (dBi)	ERP (dBm)	ERP Limit(W)	ERP Limit(dBm)	Verdict
10	Lowest	1	0	QPSK	22.73	-0.72	19.86	3.00	34.77	PASS
		1	24		23.15	-0.72	20.28	3.00	34.77	PASS
		1	49		22.67	-0.72	19.80	3.00	34.77	PASS
		25	0		22.06	-0.72	19.19	3.00	34.77	PASS
		25	12		22.02	-0.72	19.15	3.00	34.77	PASS
		25	24		21.94	-0.72	19.07	3.00	34.77	PASS
		50	0	22.04	-0.72	19.17	3.00	34.77	PASS	
		1	0	16QAM	22.51	-0.72	19.64	3.00	34.77	PASS
		1	24		22.56	-0.72	19.69	3.00	34.77	PASS
		1	49		22.04	-0.72	19.17	3.00	34.77	PASS
		25	0		20.99	-0.72	18.12	3.00	34.77	PASS
		25	12		20.98	-0.72	18.11	3.00	34.77	PASS
		25	24		20.95	-0.72	18.08	3.00	34.77	PASS
		50	0	20.97	-0.72	18.10	3.00	34.77	PASS	
		1	0	QPSK	22.97	-0.72	20.10	3.00	34.77	PASS
	1	24	22.76		-0.72	19.89	3.00	34.77	PASS	
	1	49	22.70		-0.72	19.83	3.00	34.77	PASS	
	25	0	21.41		-0.72	18.54	3.00	34.77	PASS	
	25	12	21.89		-0.72	19.02	3.00	34.77	PASS	
	25	24	21.89		-0.72	19.02	3.00	34.77	PASS	
	50	0	21.95	-0.72	19.08	3.00	34.77	PASS		
	1	0	16QAM	21.81	-0.72	18.94	3.00	34.77	PASS	
	1	24		22.18	-0.72	19.31	3.00	34.77	PASS	
	1	49		21.72	-0.72	18.85	3.00	34.77	PASS	
	25	0		20.94	-0.72	18.07	3.00	34.77	PASS	
	25	12		20.90	-0.72	18.03	3.00	34.77	PASS	
	25	24		20.84	-0.72	17.97	3.00	34.77	PASS	
	50	0	20.89	-0.72	18.02	3.00	34.77	PASS		
	1	0	QPSK	22.21	-0.72	19.34	3.00	34.77	PASS	
	1	24		22.31	-0.72	19.44	3.00	34.77	PASS	
	1	49		22.23	-0.72	19.36	3.00	34.77	PASS	
	25	0		21.84	-0.72	18.97	3.00	34.77	PASS	
	25	12		21.36	-0.72	18.49	3.00	34.77	PASS	
	25	24		21.35	-0.72	18.48	3.00	34.77	PASS	
	50	0	21.32	-0.72	18.45	3.00	34.77	PASS		
	1	0	16QAM	22.26	-0.72	19.39	3.00	34.77	PASS	
	1	24		22.36	-0.72	19.49	3.00	34.77	PASS	
	1	49		22.42	-0.72	19.55	3.00	34.77	PASS	
	25	0		20.91	-0.72	18.04	3.00	34.77	PASS	
	25	12		20.92	-0.72	18.05	3.00	34.77	PASS	
	25	24		20.90	-0.72	18.03	3.00	34.77	PASS	
	50	0	20.88	-0.72	18.01	3.00	34.77	PASS		



Radiated Power (ERP) for LTE Band 71 /15M										
BW (MHz)	UL Channel	RB Size	RB offset	Modulation	Conduction AVG Power(dBm)	Ant Gain (dBi)	ERP (dBm)	ERP Limit(W)	ERP Limit(dBm)	Verdict
15	Lowest	1	0	QPSK	22.66	-0.72	19.79	3.00	34.77	PASS
		1	37		23.13	-0.72	20.26	3.00	34.77	PASS
		1	74		22.68	-0.72	19.81	3.00	34.77	PASS
		36	0		22.02	-0.72	19.15	3.00	34.77	PASS
		36	18		22.02	-0.72	19.15	3.00	34.77	PASS
		36	39		21.59	-0.72	18.72	3.00	34.77	PASS
		75	0		21.95	-0.72	19.08	3.00	34.77	PASS
		1	0	16QAM	22.18	-0.72	19.31	3.00	34.77	PASS
		1	37		22.17	-0.72	19.30	3.00	34.77	PASS
		1	74		21.72	-0.72	18.85	3.00	34.77	PASS
		36	0		21.00	-0.72	18.13	3.00	34.77	PASS
		36	18		21.01	-0.72	18.14	3.00	34.77	PASS
		36	39		20.73	-0.72	17.86	3.00	34.77	PASS
		75	0		20.89	-0.72	18.02	3.00	34.77	PASS
	Middle	QPSK	1	0	22.52	-0.72	19.65	3.00	34.77	PASS
			1	37	22.27	-0.72	19.40	3.00	34.77	PASS
			1	74	22.33	-0.72	19.46	3.00	34.77	PASS
			36	0	21.45	-0.72	18.58	3.00	34.77	PASS
			36	18	21.91	-0.72	19.04	3.00	34.77	PASS
			36	39	21.44	-0.72	18.57	3.00	34.77	PASS
			75	0	21.96	-0.72	19.09	3.00	34.77	PASS
		16QAM	1	0	22.88	-0.72	20.01	3.00	34.77	PASS
			1	37	23.12	-0.72	20.25	3.00	34.77	PASS
			1	74	22.54	-0.72	19.67	3.00	34.77	PASS
			36	0	20.97	-0.72	18.10	3.00	34.77	PASS
			36	18	20.91	-0.72	18.04	3.00	34.77	PASS
			36	39	20.45	-0.72	17.58	3.00	34.77	PASS
			75	0	20.93	-0.72	18.06	3.00	34.77	PASS
	Highest	QPSK	1	0	22.55	-0.72	19.68	3.00	34.77	PASS
			1	37	22.48	-0.72	19.61	3.00	34.77	PASS
			1	74	22.40	-0.72	19.53	3.00	34.77	PASS
			36	0	21.45	-0.72	18.58	3.00	34.77	PASS
			36	18	21.92	-0.72	19.05	3.00	34.77	PASS
			36	39	21.31	-0.72	18.44	3.00	34.77	PASS
			75	0	21.88	-0.72	19.01	3.00	34.77	PASS
		16QAM	1	0	22.27	-0.72	19.40	3.00	34.77	PASS
1			37	22.76	-0.72	19.89	3.00	34.77	PASS	
1			74	22.41	-0.72	19.54	3.00	34.77	PASS	
36			0	20.82	-0.72	17.95	3.00	34.77	PASS	
36			18	20.93	-0.72	18.06	3.00	34.77	PASS	
36			39	20.29	-0.72	17.42	3.00	34.77	PASS	
75			0	20.90	-0.72	18.03	3.00	34.77	PASS	



Radiated Power (ERP) for LTE Band 71 /20M											
BW (MHz)	UL Channel	RB Size	RB offset	Modulation	Conduction AVG Power(dBm)	Ant Gain (dBi)	ERP (dBm)	ERP Limit(W)	ERP Limit(dBm)	Verdict	
20	Lowest	1	0	QPSK	22.48	-0.72	19.61	3.00	34.77	PASS	
		1	49		22.45	-0.72	19.58	3.00	34.77	PASS	
		1	99		22.39	-0.72	19.52	3.00	34.77	PASS	
		50	0		22.00	-0.72	19.13	3.00	34.77	PASS	
		50	24		21.48	-0.72	18.61	3.00	34.77	PASS	
		50	49		21.43	-0.72	18.56	3.00	34.77	PASS	
		100	0	21.56	-0.72	18.69	3.00	34.77	PASS		
		1	0	16QAM	22.55	-0.72	19.68	3.00	34.77	PASS	
		1	49		22.15	-0.72	19.28	3.00	34.77	PASS	
		1	99		22.57	-0.72	19.70	3.00	34.77	PASS	
		50	0		21.04	-0.72	18.17	3.00	34.77	PASS	
		50	24		21.05	-0.72	18.18	3.00	34.77	PASS	
		50	49		21.05	-0.72	18.18	3.00	34.77	PASS	
		100	0	20.98	-0.72	18.11	3.00	34.77	PASS		
		Middle	QPSK	1	0	22.49	-0.72	19.62	3.00	34.77	PASS
				1	49	22.44	-0.72	19.57	3.00	34.77	PASS
	1			99	22.49	-0.72	19.62	3.00	34.77	PASS	
	50			0	23.22	-0.72	20.35	3.00	34.77	PASS	
	50			24	21.91	-0.72	19.04	3.00	34.77	PASS	
	50			49	21.41	-0.72	18.54	3.00	34.77	PASS	
	100		0	21.86	-0.72	18.99	3.00	34.77	PASS		
	16QAM		1	0	22.48	-0.72	19.61	3.00	34.77	PASS	
			1	49	22.78	-0.72	19.91	3.00	34.77	PASS	
			1	99	22.85	-0.72	19.98	3.00	34.77	PASS	
			50	0	20.63	-0.72	17.76	3.00	34.77	PASS	
			50	24	20.92	-0.72	18.05	3.00	34.77	PASS	
			50	49	20.49	-0.72	17.62	3.00	34.77	PASS	
	100		0	20.83	-0.72	17.96	3.00	34.77	PASS		
	Highest		QPSK	1	0	22.68	-0.72	19.81	3.00	34.77	PASS
				1	49	22.61	-0.72	19.74	3.00	34.77	PASS
		1		99	22.54	-0.72	19.67	3.00	34.77	PASS	
		50		0	21.44	-0.72	18.57	3.00	34.77	PASS	
		50		24	21.40	-0.72	18.53	3.00	34.77	PASS	
		50		49	21.31	-0.72	18.44	3.00	34.77	PASS	
		100	0	21.37	-0.72	18.50	3.00	34.77	PASS		
		16QAM	1	0	22.23	-0.72	19.36	3.00	34.77	PASS	
			1	49	21.96	-0.72	19.09	3.00	34.77	PASS	
			1	99	21.76	-0.72	18.89	3.00	34.77	PASS	
			50	0	20.50	-0.72	17.63	3.00	34.77	PASS	
			50	24	20.82	-0.72	17.95	3.00	34.77	PASS	
			50	49	21.00	-0.72	18.13	3.00	34.77	PASS	
		100	0	20.94	-0.72	18.07	3.00	34.77	PASS		

5.2 PEAK TO AVERAGE RATIO

TEST OVERVIEW

According to §24.232(d), power measurements for transmissions by stations authorized under this section may be made either in accordance with a commission-approved average power technique or in compliance with paragraph (e) of this section. In both instances, equipment employed must be authorized in accordance with the provisions of §24.51. In measuring transmissions in this band using an average power technique, the peak-to-average ratio (PAR) of the transmission may not exceed 13 db.

TEST PROCEDURES

1. The testing follows FCC KDB 971168 v03r01 section.
2. The eut was connected to the peak and av system simulator& spectrum analyzer.
3. Select lowest, middle, and highest channels for each band and different modulation.
4. Set the test probe and measure average power of the spectrum analysis,

TEST SETUP

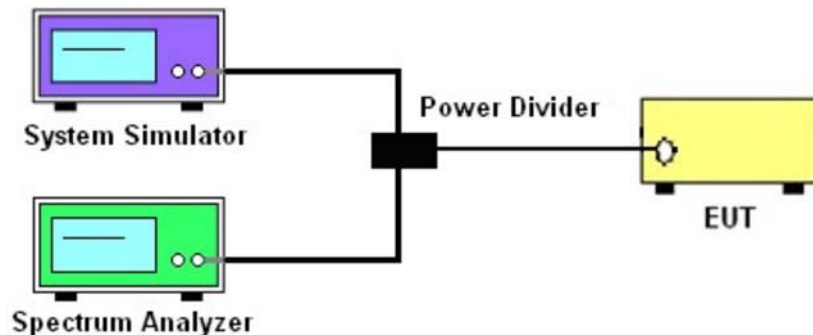

TEST RESULT

Note: The test data please reference to attachment “STS2405013W06_Appendix GSM” , “STS2405013W06_Appendix WCDMA” and “STS2405013W06_Appendix LTE”.

5.3 OCCUPIED BANDWIDTH

TEST OVERVIEW

The occupied bandwidth, that is the frequency bandwidth such that, below its lower and above its upper frequency limits, the mean powers radiated are each equal to 0.5 percent of the total mean power radiated by a given emission shall be measured.

The 26 dB emission bandwidth is defined as the frequency range between two points, one above and one below the carrier frequency, at which the spectral density of the emission is attenuated 26 dB below the maximum in-band spectral density of the modulated signal. Spectral density (power per unit bandwidth) is to be measured with a detector of resolution bandwidth equal to approximately 1.0% of the emission bandwidth.

All modes of operation were investigated and the worst case configuration results are reported in this section.

TEST PROCEDURE

1. The signal analyzer's automatic bandwidth measurement capability was used to perform the 99% occupied bandwidth and the 26dB bandwidth. The bandwidth measurement was not influenced by any intermediate power nulls in the fundamental emission.
2. RBW = 1 – 5% of the expected OBW
3. VBW \geq 3 x RBW
4. Detector = Peak
5. Trace mode = max hold
6. Sweep = auto couple
7. The trace was allowed to stabilize
8. If necessary, steps 2 – 7 were repeated after changing the RBW such that it would be within 1 – 5% of the 99% occupied bandwidth observed in Step 7

TEST SETUP

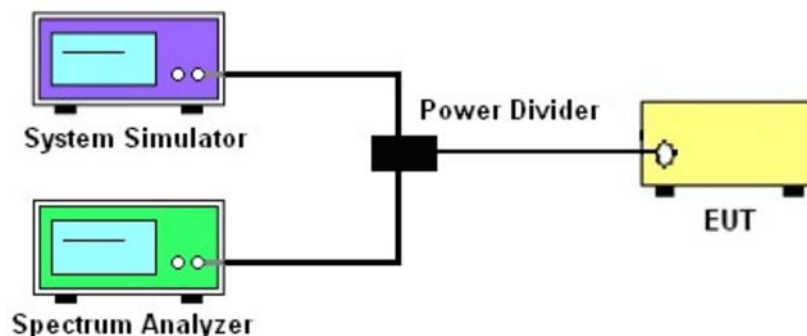

TEST RESULT

Note: The test data please reference to attachment “STS2405013W06_Appendix GSM” , “STS2405013W06_Appendix WCDMA” and “STS2405013W06_Appendix LTE”.

5.4 FREQUENCY STABILITY

TEST OVERVIEW

Frequency stability testing is performed in accordance with the guidelines of ANSI C63.26 2015.

The frequency stability of the transmitter is measured by:

- a.) Temperature: The temperature is varied from -30°C to $+50^{\circ}\text{C}$ in 10°C increments using an environmental chamber.
- b.) Primary Supply Voltage: The primary supply voltage is varied from 85% to 115% of the nominal value for non hand-carried battery and AC powered equipment. For hand-carried, battery-powered equipment, primary supply voltage is reduced to the battery operating end point which shall be specified by the manufacturer.

For Part 22, the frequency stability of the transmitter shall be maintained within $\pm 0.00025\%$ (± 2.5 ppm) of the center frequency. For Part 24 the frequency stability shall be sufficient to ensure that the fundamental emission stays within the authorized frequency block.

TEST PROCEDURE

Temperature Variation

1. The testing follows FCC KDB 971168 D01 section 9.0
2. The EUT was set up in the thermal chamber and connected with the system simulator.
3. With power OFF, the temperature was decreased to -30°C and the EUT was stabilized before testing. Power was applied and the maximum change in frequency was recorded within one minute.
4. With power OFF, the temperature was raised in 10°C steps up to 50°C . The EUT was stabilized at each step for at least half an hour. Power was applied and the maximum frequency change was recorded within one minute.

Voltage Variation

1. The testing follows FCC KDB 971168 D01 Section 9.0.
2. The EUT was placed in a temperature chamber at $25\pm 5^{\circ}\text{C}$ and connected with the system simulator.
3. The power supply voltage to the EUT was varied from 85% to 115% of the nominal value measured at the input to the EUT.
4. The variation in frequency was measured for the worst case.

TEST SETUP

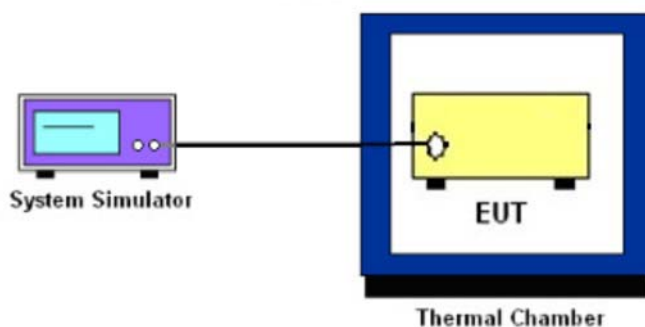

TEST RESULT

GSM 850 /836.6MHz					
Temperature (°C)	Voltage	Freq. Dev.	Freq. Dev.	Limit	Result
	(Volt)	(Hz)	(ppm)		
50	Normal Voltage	17.57	0.021	2.5ppm	PASS
40		12.46	0.015		
30		26.78	0.032		
20		17.47	0.021		
10		35.30	0.042		
0		13.60	0.016		
-10		13.21	0.016		
-20		28.88	0.035		
-30		32.26	0.039		
20		Maximum Voltage	30.01		
20	BEP	27.61	0.033		

GPRS 850 /836.6MHz					
Temperature (°C)	Voltage	Freq. Dev.	Freq. Dev.	Limit	Result
	(Volt)	(Hz)	(ppm)		
50	Normal Voltage	18.55	0.022	2.5ppm	PASS
40		32.34	0.039		
30		34.45	0.041		
20		19.65	0.023		
10		33.55	0.040		
0		17.62	0.021		
-10		12.32	0.015		
-20		13.49	0.016		
-30		18.20	0.022		
20		Maximum Voltage	26.53		
20	BEP	30.63	0.037		

EGPRS 850 /836.6MHz					
Temperature (°C)	Voltage	Freq. Dev.	Freq. Dev.	Limit	Result
	(Volt)	(Hz)	(ppm)		
50	Normal Voltage	14.41	0.017	2.5ppm	PASS
40		20.48	0.024		
30		24.50	0.029		
20		23.42	0.028		
10		17.22	0.021		
0		14.95	0.018		
-10		24.89	0.030		
-20		20.86	0.025		
-30		15.14	0.018		
20		Maximum Voltage	20.24		
20	BEP	20.32	0.024		



GSM 1900 / 1880MHz					
Temperature (°C)	Voltage	Freq. Dev.	Freq. Dev.	Limit	Result
	(Volt)	(Hz)	(ppm)		
50	Normal Voltage	28.95	0.015	Within Authorized Band	PASS
40		31.00	0.016		
30		34.98	0.019		
20		18.99	0.010		
10		13.50	0.007		
0		24.17	0.013		
-10		26.20	0.014		
-20		18.83	0.010		
-30		21.56	0.011		
20		Maximum Voltage	13.52		
20	BEP	16.63	0.009		

GPRS 1900 / 1880MHz					
Temperature (°C)	Voltage	Freq. Dev.	Freq. Dev.	Limit	Result
	(Volt)	(Hz)	(ppm)		
50	Normal Voltage	14.87	0.008	Within Authorized Band	PASS
40		32.82	0.017		
30		13.21	0.007		
20		24.13	0.013		
10		32.44	0.017		
0		19.00	0.010		
-10		17.16	0.009		
-20		11.75	0.006		
-30		32.08	0.017		
20		Maximum Voltage	34.71		
20	BEP	32.29	0.017		

EGPRS 1900 / 1880MHz					
Temperature (°C)	Voltage	Freq. Dev.	Freq. Dev.	Limit	Result
	(Volt)	(Hz)	(ppm)		
50	Normal Voltage	18.89	0.010	Within Authorized Band	PASS
40		21.17	0.011		
30		26.06	0.014		
20		22.48	0.012		
10		29.14	0.016		
0		30.04	0.016		
-10		31.04	0.017		
-20		33.80	0.018		
-30		13.78	0.007		
20		Maximum Voltage	34.98		
20	BEP	17.85	0.009		



LTE Band 2 (QPSK) / 1880MHz / BW10M					
Temperature (°C)	Voltage	Freq. Dev.	Freq. Dev.	Limit	Result
	(Volt)	(Hz)	(ppm)		
50	Normal Voltage	32.77	0.017	2.5ppm	PASS
40		25.60	0.014		
30		21.15	0.011		
20		33.97	0.018		
10		31.96	0.017		
0		19.17	0.010		
-10		13.73	0.007		
-20		26.63	0.014		
-30		13.91	0.007		
20		Maximum Voltage	34.47		
20	BEP	22.42	0.012		

LTE Band 2 (QPSK) / 1880MHz / BW20M					
Temperature (°C)	Voltage	Freq. Dev.	Freq. Dev.	Limit	Result
	(Volt)	(Hz)	(ppm)		
50	Normal Voltage	18.11	0.010	2.5ppm	PASS
40		16.12	0.009		
30		16.82	0.009		
20		29.83	0.016		
10		22.90	0.012		
0		26.21	0.014		
-10		14.95	0.008		
-20		35.50	0.019		
-30		30.30	0.016		
20		Maximum Voltage	24.38		
20	BEP	14.12	0.008		

LTE Band 4 (QPSK) / 1733MHz / BW10M					
Temperature (°C)	Voltage	Freq. Dev.	Freq. Dev.	Limit	Result
	(Volt)	(Hz)	(ppm)		
50	Normal Voltage	28.64	0.017	2.5ppm	PASS
40		35.46	0.020		
30		21.48	0.012		
20		17.97	0.010		
10		35.43	0.020		
0		28.30	0.016		
-10		28.62	0.017		
-20		34.73	0.020		
-30		31.15	0.018		
20		Maximum Voltage	15.85		
20	BEP	36.35	0.021		



LTE Band 4 (QPSK) / 1733MHz / BW20M					
Temperature (°C)	Voltage	Freq. Dev.	Freq. Dev.	Limit	Result
	(Volt)	(Hz)	(ppm)		
50	Normal Voltage	12.22	0.007	2.5ppm	PASS
40		18.91	0.011		
30		24.43	0.014		
20		15.66	0.009		
10		23.94	0.014		
0		13.17	0.008		
-10		16.93	0.010		
-20		19.76	0.011		
-30		15.61	0.009		
20		Maximum Voltage	30.97		
20	BEP	26.94	0.016		

LTE Band 5 (QPSK) / 836.5MHz / BW5M					
Temperature (°C)	Voltage	Freq. Dev.	Freq. Dev.	Limit	Result
	(Volt)	(Hz)	(ppm)		
50	Normal Voltage	31.38	0.044	2.5ppm	PASS
40		20.63	0.029		
30		20.60	0.029		
20		33.64	0.047		
10		18.51	0.026		
0		19.15	0.027		
-10		17.41	0.002		
-20		30.98	0.044		
-30		12.55	0.018		
20		Maximum Voltage	28.94		
20	BEP	12.85	0.018		

LTE Band 5 (QPSK) / 836.5MHz / BW10M					
Temperature (°C)	Voltage	Freq. Dev.	Freq. Dev.	Limit	Result
	(Volt)	(Hz)	(ppm)		
50	Normal Voltage	15.34	0.022	2.5ppm	PASS
40		14.84	0.021		
30		22.96	0.032		
20		26.08	0.037		
10		17.83	0.025		
0		30.21	0.043		
-10		35.58	0.005		
-20		21.95	0.031		
-30		21.92	0.031		
20		Maximum Voltage	21.27		
20	BEP	25.19	0.035		



LTE Band 12 (QPSK) / 707.5MHz / BW5M					
Temperature (°C)	Voltage	Freq. Dev.	Freq. Dev.	Limit	Result
	(Volt)	(Hz)	(ppm)		
50	Normal Voltage	34.81	0.049	2.5ppm	PASS
40		31.85	0.045		
30		18.59	0.026		
20		35.35	0.050		
10		32.57	0.046		
0		12.45	0.018		
-10		12.56	0.002		
-20		14.39	0.020		
-30		30.34	0.043		
20		Maximum Voltage	19.58		
20	BEP	17.06	0.024		

LTE Band 12 (QPSK) / 707.5MHz / BW10M					
Temperature (°C)	Voltage	Freq. Dev.	Freq. Dev.	Limit	Result
	(Volt)	(Hz)	(ppm)		
50	Normal Voltage	30.74	0.043	2.5ppm	PASS
40		21.00	0.030		
30		17.79	0.025		
20		18.95	0.027		
10		28.37	0.040		
0		13.99	0.020		
-10		20.63	0.003		
-20		25.50	0.036		
-30		36.45	0.051		
20		Maximum Voltage	15.85		
20	BEP	33.48	0.047		

LTE Band 13 (QPSK) / 782MHz / BW5M					
Temperature (°C)	Voltage	Freq. Dev.	Freq. Dev.	Limit	Result
	(Volt)	(Hz)	(ppm)		
50	Normal Voltage	18.41	0.026	2.5ppm	PASS
40		28.94	0.041		
30		15.81	0.022		
20		22.08	0.031		
10		33.84	0.048		
0		21.05	0.030		
-10		22.83	0.003		
-20		27.63	0.039		
-30		22.36	0.031		
20		Maximum Voltage	36.28		
20	BEP	13.66	0.019		



LTE Band 13 (QPSK) / 782MHz / BW10M					
Temperature (°C)	Voltage	Freq. Dev.	Freq. Dev.	Limit	Result
	(Volt)	(Hz)	(ppm)		
50	Normal Voltage	31.75	0.045	2.5ppm	PASS
40		32.28	0.045		
30		12.92	0.018		
20		16.53	0.023		
10		35.25	0.050		
0		35.13	0.049		
-10		15.44	0.002		
-20		25.27	0.036		
-30		31.36	0.044		
20		Maximum Voltage	34.46		
20	BEP	23.79	0.034		

LTE Band 25 (QPSK) / 1882.5MHz / BW10M					
Temperature (°C)	Voltage	Freq. Dev.	Freq. Dev.	Limit	Result
	(Volt)	(Hz)	(ppm)		
50	Normal Voltage	23.29	0.012	2.5ppm	PASS
40		33.78	0.018		
30		31.92	0.017		
20		35.51	0.019		
10		34.15	0.018		
0		12.28	0.007		
-10		36.26	0.019		
-20		26.40	0.014		
-30		22.90	0.012		
20		Maximum Voltage	36.10		
20	BEP	27.87	0.015		

LTE Band 25 (QPSK) / 1882.5MHz / BW20M					
Temperature (°C)	Voltage	Freq. Dev.	Freq. Dev.	Limit	Result
	(Volt)	(Hz)	(ppm)		
50	Normal Voltage	22.68	0.012	2.5ppm	PASS
40		22.52	0.012		
30		13.92	0.007		
20		29.50	0.016		
10		26.25	0.014		
0		19.22	0.010		
-10		26.90	0.014		
-20		14.57	0.008		
-30		25.84	0.014		
20		Maximum Voltage	13.08		
20	BEP	20.19	0.011		



LTE Band 26 Part22 (QPSK) / 836.5MHz / BW10M					
Temperature (°C)	Voltage	Freq. Dev.	Freq. Dev.	Limit	Result
	(Volt)	(Hz)	(ppm)		
50	Normal Voltage	30.44	0.018	2.5ppm	PASS
40		35.12	0.020		
30		30.94	0.018		
20		17.68	0.010		
10		25.61	0.015		
0		21.87	0.013		
-10		21.11	0.012		
-20		23.80	0.014		
-30		24.89	0.014		
20		Maximum Voltage	34.86		
20	BEP	27.41	0.016		

LTE Band 26 Part22 (QPSK) / 836.5MHz / BW20M					
Temperature (°C)	Voltage	Freq. Dev.	Freq. Dev.	Limit	Result
	(Volt)	(Hz)	(ppm)		
50	Normal Voltage	27.64	0.016	2.5ppm	PASS
40		15.85	0.009		
30		27.44	0.016		
20		16.99	0.010		
10		12.36	0.007		
0		23.01	0.013		
-10		18.34	0.011		
-20		22.81	0.013		
-30		19.21	0.011		
20		Maximum Voltage	17.54		
20	BEP	22.84	0.013		

LTE Band 26 Part90 (QPSK) / 819MHz / BW5M					
Temperature (°C)	Voltage	Freq. Dev.	Freq. Dev.	Limit	Result
	(Volt)	(Hz)	(ppm)		
50	Normal Voltage	18.98	0.011	2.5ppm	PASS
40		31.51	0.018		
30		24.34	0.014		
20		24.04	0.014		
10		36.49	0.021		
0		30.71	0.018		
-10		18.62	0.011		
-20		23.39	0.013		
-30		18.19	0.010		
20		Maximum Voltage	18.83		
20	BEP	14.07	0.008		



LTE Band 26 Part90 (QPSK) / 819MHz / BW10M					
Temperature (°C)	Voltage	Freq. Dev.	Freq. Dev.	Limit	Result
	(Volt)	(Hz)	(ppm)		
50	Normal Voltage	34.80	0.020	2.5ppm	PASS
40		13.77	0.008		
30		30.93	0.018		
20		33.51	0.019		
10		14.52	0.008		
0		35.20	0.020		
-10		22.88	0.013		
-20		27.67	0.016		
-30		33.03	0.019		
20		Maximum Voltage	28.59		
20	BEP	24.57	0.014		

LTE Band 41 (QPSK) / 2593MHz / BW10M					
Temperature (°C)	Voltage	Freq. Dev.	Freq. Dev.	Limit	Result
	(Volt)	(Hz)	(ppm)		
50	Normal Voltage	19.88	0.008	2.5ppm	PASS
40		19.33	0.008		
30		28.40	0.011		
20		21.01	0.008		
10		22.28	0.009		
0		31.29	0.012		
-10		25.75	0.010		
-20		22.57	0.009		
-30		13.53	0.005		
20		Maximum Voltage	13.54		
20	BEP	34.09	0.013		

LTE Band 41 (QPSK) / 2593MHz / BW20M					
Temperature (°C)	Voltage	Freq. Dev.	Freq. Dev.	Limit	Result
	(Volt)	(Hz)	(ppm)		
50	Normal Voltage	17.99	0.007	2.5ppm	PASS
40		24.70	0.010		
30		22.97	0.009		
20		29.17	0.012		
10		27.03	0.011		
0		35.83	0.014		
-10		34.93	0.014		
-20		30.30	0.012		
-30		22.96	0.009		
20		Maximum Voltage	13.66		
20	BEP	35.29	0.014		



LTE Band 66 (QPSK) / 1745MHz / BW10M					
Temperature (°C)	Voltage	Freq. Dev.	Freq. Dev.	Limit	Result
	(Volt)	(Hz)	(ppm)		
50	Normal Voltage	13.10	0.008	2.5ppm	PASS
40		14.19	0.008		
30		17.95	0.010		
20		19.82	0.011		
10		16.36	0.009		
0		36.46	0.021		
-10		13.33	0.008		
-20		24.72	0.014		
-30		18.24	0.011		
20		Maximum Voltage	30.08		
20	BEP	29.94	0.017		

LTE Band 66 (QPSK) / 1745MHz / BW20M					
Temperature (°C)	Voltage	Freq. Dev.	Freq. Dev.	Limit	Result
	(Volt)	(Hz)	(ppm)		
50	Normal Voltage	31.56	0.018	2.5ppm	PASS
40		35.81	0.021		
30		29.77	0.017		
20		17.66	0.010		
10		20.53	0.012		
0		26.59	0.015		
-10		25.57	0.015		
-20		17.54	0.010		
-30		22.50	0.013		
20		Maximum Voltage	16.43		
20	BEP	16.07	0.009		

LTE Band 71 (QPSK) / 680.5MHz / BW10M					
Temperature (°C)	Voltage	Freq. Dev.	Freq. Dev.	Limit	Result
	(Volt)	(Hz)	(ppm)		
50	Normal Voltage	12.36	0.017	2.5ppm	PASS
40		35.59	0.050		
30		23.33	0.033		
20		21.89	0.031		
10		19.59	0.028		
0		14.44	0.020		
-10		22.24	0.003		
-20		28.48	0.040		
-30		31.73	0.045		
20		Maximum Voltage	22.93		
20	BEP	35.20	0.050		



LTE Band 71 (QPSK) / 680.5MHz / BW20M					
Temperature (°C)	Voltage	Freq. Dev.	Freq. Dev.	Limit	Result
	(Volt)	(Hz)	(ppm)		
50	Normal Voltage	25.47	0.036	2.5ppm	PASS
40		21.05	0.030		
30		12.95	0.018		
20		31.26	0.044		
10		27.56	0.039		
0		13.93	0.020		
-10		35.04	0.005		
-20		23.87	0.034		
-30		23.14	0.033		
20		Maximum Voltage	12.09		
20	BEP	33.80	0.048		

5.5 SPURIOUS EMISSIONS AT ANTENNA TERMINALS TEST OVERVIEW

The power of any emission outside of the authorized operating frequency ranges must be lower than the transmitter power (P) by a factor of at least $43 + 10 \log (P)$ dB.

For Band 7:

The power of any emission outside of the authorized operating frequency ranges must be lower than the transmitter power (P) by a factor of at least $55 + 10 \log (P)$ dB.

It is measured by means of a calibrated spectrum analyzer and scanned from 30 MHz up to a frequency including its 10th harmonic.

TEST PROCEDURE

1. The testing FCC KDB 971168 D01 v03r01 Section 6.0. and ANSI C63.26-2015-Section 5.7.
2. The EUT was connected to the spectrum analyzer and system simulator via a power divider.
3. The RF output of EUT was connected to the spectrum analyzer by an RF cable and attenuator. The path loss was compensated to the results for each measurement.
4. The middle channel for the highest RF power within the transmitting frequency was measured.
5. The conducted spurious emission for the whole frequency range was taken.
6. The RF fundamental frequency should be excluded against the limit line in the operating frequency band.
7. The limit line is derived from $43 + 10\log(P)$ dB below the transmitter power P(Watts)
 $= P(W) - [43 + 10\log(P)]$ (dB)
 $= [30 + 10\log(P)]$ (dBm) - $[43 + 10\log(P)]$ (dB)
 $= -13\text{dBm}$.

TEST SETUP

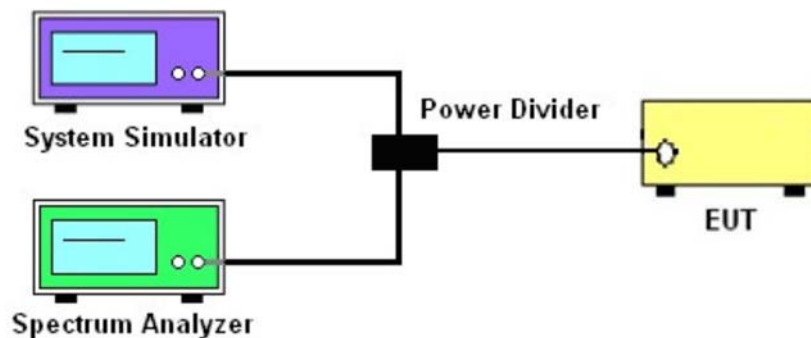

TEST RESULT

Note: The test data please reference to attachment “STS2405013W06_Appendix GSM” , “STS2405013W06_Appendix WCDMA” and “STS2405013W06_Appendix LTE”.



5.6 BAND EDGE

TEST OVERVIEW

1. §22.917(a)

For operations in the 824 – 849 MHz band, the FCC limit is $43 + 10\log_{10}(P[\text{Watts}])$ dB below the transmitter power $P(\text{Watts})$ in a 100kHz bandwidth. However, in the 1MHz bands immediately outside and adjacent to the licensee's frequency block, a resolution bandwidth of at least one percent of the emission bandwidth of the fundamental emission of the transmitter may be employed.

2. §24.238 (a)

For operations in the 1850-1910 and 1930-1990 MHz band, the FCC limit is $43 + 10\log_{10}(P[\text{Watts}])$ dB below the transmitter power $P(\text{Watts})$ in a 1MHz bandwidth. However, in the 1 MHz bands immediately outside and adjacent to the frequency block a resolution bandwidth of at least one percent of the emission bandwidth of the fundamental emission of the transmitter may be employed

3. §27.53 (h)

For operations in the 1710 – 1755 MHz band, the FCC limit is $43 + 10\log_{10}(P[\text{Watts}])$ dB below the transmitter power $P(\text{Watts})$ in a 1 MHz bandwidth. However, in the 1MHz bands immediately outside and adjacent to the licensee's frequency block, a resolution bandwidth of at least one percent of the emission bandwidth of the fundamental emission of the transmitter may be employed.

4. §27.53(m)(4)

For operations in the 2500 MHz ~ 2570 MHz band this section, the attenuation factor shall be not less than $40 + 10 \log (P)$ dB on all frequencies between the channel edge and 5 megahertz from the channel edge, $43 + 10 \log (P)$ dB on all frequencies between 5 megahertz and X megahertz from the channel edge, and $55 + 10 \log (P)$ dB on all frequencies more than X megahertz from the channel edge, where X is the greater of 6 megahertz or the actual emission bandwidth as defined in paragraph (m)(6) of this section. In addition, the attenuation factor shall not be less that $43 + 10 \log (P)$ dB on all frequencies between 2490.5 MHz and 2496 MHz and $55 + 10 \log (P)$ dB at or below 2490.5 MHz. Mobile Satellite Service licensees operating on frequencies below 2495 MHz may also submit a documented interference complaint against BRS licensees operating on channel BRS Channel 1 on the same terms and conditions as adjacent channel BRS or EBS licensees.

5. §27.53 (g)

For operations in the 698 -746 MHz band, the FCC limit is $43 + 10\log_{10}(P[\text{Watts}])$ dB below the transmitter power $P(\text{Watts})$ in a 100 kHz bandwidth. However, in the 100 kilohertz bands immediately outside and adjacent to a licensee's frequency block, a resolution bandwidth of at least 30 kHz may be employed.

TEST PROCEDURE

1. The testing FCC KDB 971168 D01 v03r01 Section 6.0 and ANSI C63.26-2015-Section 5.7
2. Start and stop frequency were set such that the band edge would be placed in the center of the Plot.
3. The EUT was connected to the spectrum analyzer and system simulator via a power divider.
4. The RF output of EUT was connected to the spectrum analyzer by an RF cable and attenuator. The path loss was compensated to the results for each measurement.
5. The band edges of low and high channels for the highest RF powers were measured.
6. The RF fundamental frequency should be excluded against the limit line in the operating frequency band.

7. The limit line is derived from $43 + 10\log(P)$ dB below the transmitter power P(Watts)

$$= P(W) - [43 + 10\log(P)] \text{ (dB)}$$

$$= [30 + 10\log(P)] \text{ (dBm)} - [43 + 10\log(P)] \text{ (dB)}$$

$$= -13\text{dBm.}$$

Band 7:

$$= P(W) - [55 + 10\log(P)] \text{ (dB)}$$

$$= [30 + 10\log(P)] \text{ (dBm)} - [55 + 10\log(P)] \text{ (dB)}$$

$$= -25\text{dBm.}$$

TEST SETUP

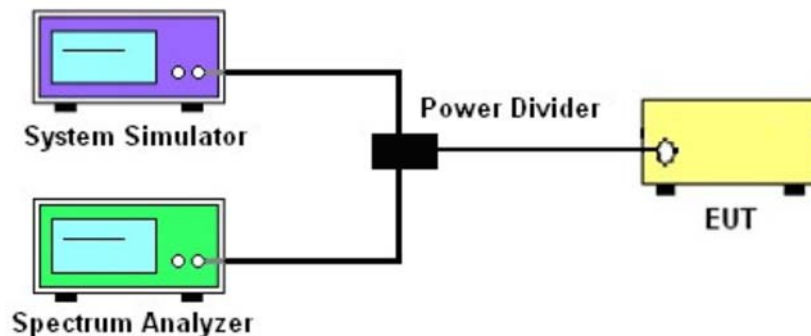

TEST RESULT

Note: The test data please reference to attachment "STS2405013W06_Appendix GSM", "STS2405013W06_Appendix WCDMA" and "STS2405013W06_Appendix LTE".



5.7 FIELD STRENGTH OF SPURIOUS RADIATION MEASUREMENT

TEST OVERVIEW

Radiated spurious emissions measurements are performed using the substitution method described in ANSI C63.26-2015 with the EUT transmitting into an integral antenna. Measurements on signals operating below 1GHz are performed using horizontally and vertically polarized tuned dipole antennas. Measurements on signals operating above 1GHz are performed using vertically and horizontally polarized horn antennas. All measurements are performed as peak measurements while the EUT is operating at maximum power and at the appropriate frequencies.

It is measured by means of a calibrated spectrum analyzer and scanned from 30 MHz up to a frequency including its 10th harmonic.

TEST PROCEDURE

1. The testing FCC KDB 971168 D01 Section 5.8 and ANSI C63.26-2015-Section 5.5.
2. RBW = 100kHz for emissions below 1GHz and 1MHz for emissions above 1GHz
3. VBW $\geq 3 \times$ RBW
4. Span = 1.5 times the OBW
5. No. of sweep points $> 2 \times$ span/RBW
6. Detector = Peak
7. Trace mode = max hold
8. The trace was allowed to stabilize
9. Effective Isotropic Spurious Radiation was measured by substitution method according to TIA/EIA-603-D. The EUT was replaced by the substitution antenna at same location, and then a known power from S.G. was applied into the dipole antenna through a Tx cable, and then recorded the maximum Analyzer reading through raised and lowered the test antenna.
PMea=S.G Level+ Ant-Cable loss; Margin=PMea-Limit.

TEST SETUP

For radiated test from 30MHz to 1GHz

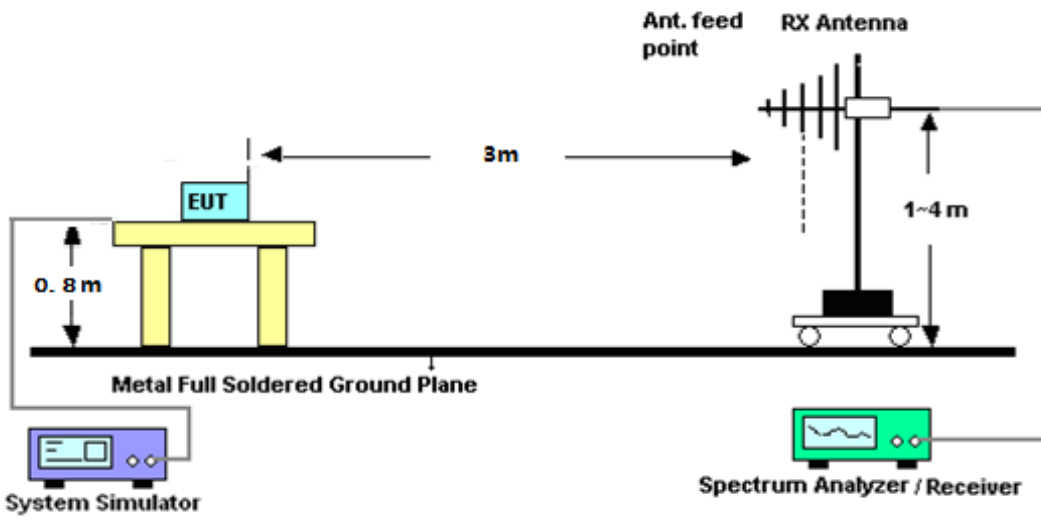

For radiated test from above 1GHz

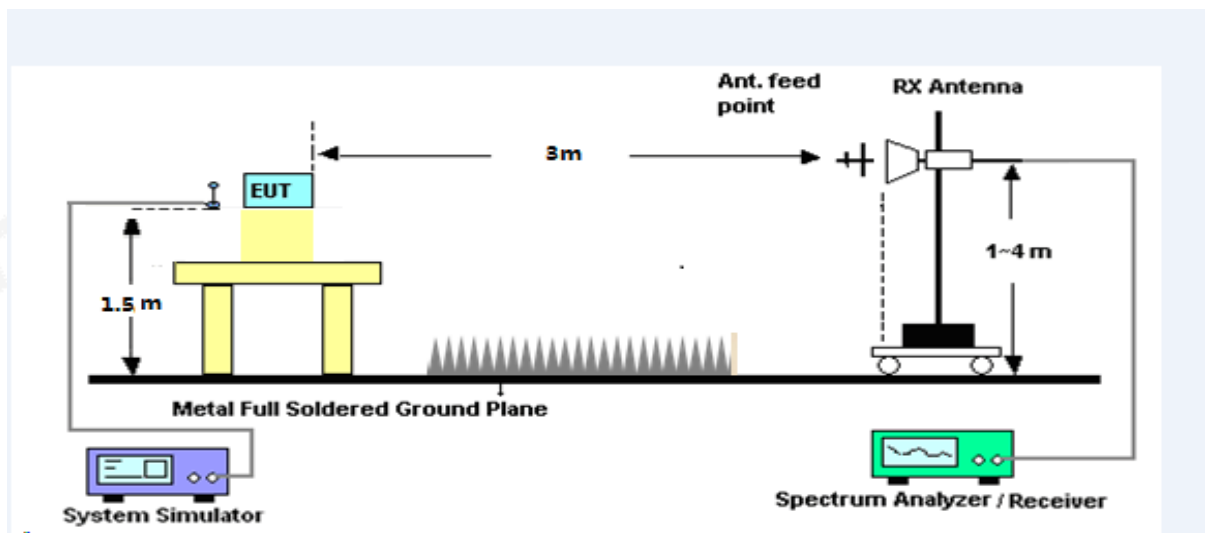

**TEST RESULT**

- Note:** (1) Spurious emissions which are attenuated by more than 20dB below the permissible value for frequency below 1000MHz.
- (2) Above 3.5GHz amplitude of spurious emissions which are attenuated by more than 20dB below the permissible value
- (3) Test is divided into three directions, X/Y/Z. X pattern for the worst.

Model: MOJO

GSM 850: (30-9000)MHz							
The Worst Test Results Channel 128/824.2 MHz							
Frequency(MHz)	S	Ant(dBi)	Loss	PMea	Limit	Margin	Polarity
	G.Lev (dBm)			(dBm)	(dBm)	(dBm)	
1648.46	-40.17	9.40	4.75	-35.52	-13.00	-22.52	H
2472.40	-39.95	10.60	8.39	-37.74	-13.00	-24.74	H
3296.76	-31.02	12.00	11.79	-30.81	-13.00	-17.81	H
1648.46	-43.57	9.40	4.75	-38.92	-13.00	-25.92	V
2472.40	-45.44	10.60	8.39	-43.23	-13.00	-30.23	V
3296.76	-42.87	12.00	11.79	-42.66	-13.00	-29.66	V
The Worst Test Results Channel 190/836.6 MHz							
Frequency(MHz)	S	Ant(dBi)	Loss	PMea	Limit	Margin	Polarity
	G.Lev (dBm)			(dBm)	(dBm)	(dBm)	
1673.24	-40.76	9.50	4.76	-36.02	-13.00	-23.02	H
2509.70	-40.21	10.70	8.40	-37.91	-13.00	-24.91	H
3345.97	-31.96	12.20	11.80	-31.56	-13.00	-18.56	H
1673.24	-43.98	9.40	4.75	-39.33	-13.00	-26.33	V
2509.70	-44.25	10.60	8.39	-42.04	-13.00	-29.04	V
3345.97	-42.81	12.20	11.82	-42.43	-13.00	-29.43	V
The Worst Test Results Channel 251/848.8 MHz							
Frequency(MHz)	S	Ant(dBi)	Loss	PMea	Limit	Margin	Polarity
	G.Lev (dBm)			(dBm)	(dBm)	(dBm)	
1697.46	-41.54	9.60	4.77	-36.71	-13.00	-23.71	H
2546.37	-39.49	10.80	8.50	-37.19	-13.00	-24.19	H
3395.23	-31.99	12.50	11.90	-31.39	-13.00	-18.39	H
1697.46	-43.30	9.60	4.77	-38.47	-13.00	-25.47	V
2546.37	-45.08	10.80	8.50	-42.78	-13.00	-29.78	V
3395.23	-43.43	12.50	11.90	-42.83	-13.00	-29.83	V



GPRS 850: (30-9000)MHz							
The Worst Test Results Channel 128/824.2 MHz							
Frequency(MHz)	S	Ant(dBi)	Loss	PMea	Limit	Margin	Polarity
	G.Lev (dBm)			(dBm)	(dBm)	(dBm)	
1648.26	-40.32	9.40	4.75	-35.67	-13.00	-22.67	H
2472.51	-40.20	10.60	8.39	-37.99	-13.00	-24.99	H
3296.74	-32.32	12.00	11.79	-32.11	-13.00	-19.11	H
1648.26	-43.72	9.40	4.75	-39.07	-13.00	-26.07	V
2472.51	-45.04	10.60	8.39	-42.83	-13.00	-29.83	V
3296.74	-43.28	12.00	11.79	-43.07	-13.00	-30.07	V
The Worst Test Results Channel 190/836.6 MHz							
Frequency(MHz)	S	Ant(dBi)	Loss	PMea	Limit	Margin	Polarity
	G.Lev (dBm)			(dBm)	(dBm)	(dBm)	
1673.03	-41.44	9.50	4.76	-36.70	-13.00	-23.70	H
2509.78	-40.63	10.70	8.40	-38.33	-13.00	-25.33	H
3346.34	-32.22	12.20	11.80	-31.82	-13.00	-18.82	H
1673.03	-43.97	9.40	4.75	-39.32	-13.00	-26.32	V
2509.78	-44.70	10.60	8.39	-42.49	-13.00	-29.49	V
3346.34	-42.52	12.20	11.82	-42.14	-13.00	-29.14	V
The Worst Test Results Channel 251/848.8 MHz							
Frequency(MHz)	S	Ant(dBi)	Loss	PMea	Limit	Margin	Polarity
	G.Lev (dBm)			(dBm)	(dBm)	(dBm)	
1697.42	-40.19	9.60	4.77	-35.36	-13.00	-22.36	H
2546.44	-39.88	10.80	8.50	-37.58	-13.00	-24.58	H
3395.01	-31.55	12.50	11.90	-30.95	-13.00	-17.95	H
1697.42	-43.25	9.60	4.77	-38.42	-13.00	-25.42	V
2546.44	-44.50	10.80	8.50	-42.20	-13.00	-29.20	V
3395.01	-43.96	12.50	11.90	-43.36	-13.00	-30.36	V



EGPRS 850: (30-9000)MHz							
The Worst Test Results Channel 128/824.2 MHz							
Frequency(MHz)	S		Loss	PMea	Limit	Margin	Polarity
	G.Lev (dBm)	Ant(dBi)		(dBm)	(dBm)	(dBm)	
1648.46	-40.33	9.40	4.75	-35.68	-13.00	-22.68	H
2472.63	-40.19	10.60	8.39	-37.98	-13.00	-24.98	H
3296.87	-31.19	12.00	11.79	-30.98	-13.00	-17.98	H
1648.46	-43.36	9.40	4.75	-38.71	-13.00	-25.71	V
2472.63	-43.95	10.60	8.39	-41.74	-13.00	-28.74	V
3296.87	-43.90	12.00	11.79	-43.69	-13.00	-30.69	V
The Worst Test Results Channel 190/836.6 MHz							
Frequency(MHz)	S		Loss	PMea	Limit	Margin	Polarity
	G.Lev (dBm)	Ant(dBi)		(dBm)	(dBm)	(dBm)	
1673.18	-41.08	9.50	4.76	-36.34	-13.00	-23.34	H
2509.82	-39.77	10.70	8.40	-37.47	-13.00	-24.47	H
3346.08	-32.27	12.20	11.80	-31.87	-13.00	-18.87	H
1673.18	-43.98	9.40	4.75	-39.33	-13.00	-26.33	V
2509.82	-44.32	10.60	8.39	-42.11	-13.00	-29.11	V
3346.08	-43.54	12.20	11.82	-43.16	-13.00	-30.16	V
The Worst Test Results Channel 251/848.8 MHz							
Frequency(MHz)	S		Loss	PMea	Limit	Margin	Polarity
	G.Lev (dBm)	Ant(dBi)		(dBm)	(dBm)	(dBm)	
1697.35	-41.09	9.60	4.77	-36.26	-13.00	-23.26	H
2546.08	-39.64	10.80	8.50	-37.34	-13.00	-24.34	H
3394.90	-31.53	12.50	11.90	-30.93	-13.00	-17.93	H
1697.35	-44.44	9.60	4.77	-39.61	-13.00	-26.61	V
2546.08	-45.14	10.80	8.50	-42.84	-13.00	-29.84	V
3394.90	-43.45	12.50	11.90	-42.85	-13.00	-29.85	V



PCS 1900: (30-20000)MHz							
The Worst Test Results for Channel 512/1850.2MHz							
Frequency(MHz)	S	Ant(dBi)	Loss	PMea	Limit	Margin	Polarity
	G.Lev (dBm)			(dBm)	(dBm)	(dBm)	
3700.01	-34.06	12.60	12.93	-34.39	-13.00	-21.39	H
5550.62	-34.92	13.10	17.11	-38.93	-13.00	-25.93	H
7400.74	-33.24	11.50	22.20	-43.94	-13.00	-30.94	H
3700.01	-35.71	12.60	12.93	-36.04	-13.00	-23.04	V
5550.62	-35.07	13.10	17.11	-39.08	-13.00	-26.08	V
7400.74	-32.49	11.50	22.20	-43.19	-13.00	-30.19	V
The Worst Test Results for Channel 661/1880.0MHz							
Frequency(MHz)	S	Ant(dBi)	Loss	PMea	Limit	Margin	Polarity
	G.Lev (dBm)			(dBm)	(dBm)	(dBm)	
3760.24	-34.18	12.60	12.93	-34.51	-13.00	-21.51	H
5640.04	-34.33	13.10	17.11	-38.34	-13.00	-25.34	H
7519.94	-33.59	11.50	22.20	-44.29	-13.00	-31.29	H
3760.24	-34.91	12.60	12.93	-35.24	-13.00	-22.24	V
5640.04	-34.73	13.10	17.11	-38.74	-13.00	-25.74	V
7519.94	-31.74	11.50	22.20	-42.44	-13.00	-29.44	V
The Worst Test Results for Channel 810/1909.8MHz							
Frequency(MHz)	S	Ant(dBi)	Loss	PMea	Limit	Margin	Polarity
	G.Lev (dBm)			(dBm)	(dBm)	(dBm)	
3819.61	-34.91	12.60	12.93	-35.24	-13.00	-22.24	H
5729.01	-34.70	13.10	17.11	-38.71	-13.00	-25.71	H
7638.84	-32.24	11.50	22.20	-42.94	-13.00	-29.94	H
3819.61	-35.27	12.60	12.93	-35.60	-13.00	-22.60	V
5729.01	-34.15	13.10	17.11	-38.16	-13.00	-25.16	V
7638.84	-32.00	11.50	22.20	-42.70	-13.00	-29.70	V



GPRS1900: (30-20000)MHz							
The Worst Test Results for Channel 512/1850.2MHz							
Frequency(MHz)	S	Ant(dBi)	Loss	PMea	Limit	Margin	Polarity
	G.Lev (dBm)			(dBm)	(dBm)	(dBm)	
3700.31	-33.89	12.60	12.93	-34.22	-13.00	-21.22	H
5550.63	-35.11	13.10	17.11	-39.12	-13.00	-26.12	H
7400.89	-32.91	11.50	22.20	-43.61	-13.00	-30.61	H
3700.31	-35.97	12.60	12.93	-36.30	-13.00	-23.30	V
5550.63	-34.12	13.10	17.11	-38.13	-13.00	-25.13	V
7400.89	-32.04	11.50	22.20	-42.74	-13.00	-29.74	V
The Worst Test Results for Channel 661/1880.0MHz							
Frequency(MHz)	S	Ant(dBi)	Loss	PMea	Limit	Margin	Polarity
	G.Lev (dBm)			(dBm)	(dBm)	(dBm)	
3759.88	-34.33	12.60	12.93	-34.66	-13.00	-21.66	H
5640.28	-34.42	13.10	17.11	-38.43	-13.00	-25.43	H
7520.05	-32.88	11.50	22.20	-43.58	-13.00	-30.58	H
3759.88	-35.91	12.60	12.93	-36.24	-13.00	-23.24	V
5640.28	-34.36	13.10	17.11	-38.37	-13.00	-25.37	V
7520.05	-32.24	11.50	22.20	-42.94	-13.00	-29.94	V
The Worst Test Results for Channel 810/1909.8MHz							
Frequency(MHz)	S	Ant(dBi)	Loss	PMea	Limit	Margin	Polarity
	G.Lev (dBm)			(dBm)	(dBm)	(dBm)	
3819.60	-33.54	12.60	12.93	-33.87	-13.00	-20.87	H
5729.21	-35.11	13.10	17.11	-39.12	-13.00	-26.12	H
7639.09	-32.65	11.50	22.20	-43.35	-13.00	-30.35	H
3819.60	-35.15	12.60	12.93	-35.48	-13.00	-22.48	V
5729.21	-34.67	13.10	17.11	-38.68	-13.00	-25.68	V
7639.09	-31.74	11.50	22.20	-42.44	-13.00	-29.44	V



EGPRS 1900: (30-20000)MHz							
The Worst Test Results for Channel 512/1850.2MHz							
Frequency(MHz)	S	Ant(dBi)	Loss	PMea	Limit	Margin	Polarity
	G.Lev (dBm)			(dBm)	(dBm)	(dBm)	
3700.19	-34.35	12.60	12.93	-34.68	-13.00	-21.68	H
5550.42	-34.86	13.10	17.11	-38.87	-13.00	-25.87	H
7400.74	-33.58	11.50	22.20	-44.28	-13.00	-31.28	H
3700.19	-36.01	12.60	12.93	-36.34	-13.00	-23.34	V
5550.42	-35.24	13.10	17.11	-39.25	-13.00	-26.25	V
7400.74	-33.19	11.50	22.20	-43.89	-13.00	-30.89	V
The Worst Test Results for Channel 661/1880.0MHz							
Frequency(MHz)	S	Ant(dBi)	Loss	PMea	Limit	Margin	Polarity
	G.Lev (dBm)			(dBm)	(dBm)	(dBm)	
3759.87	-33.70	12.60	12.93	-34.03	-13.00	-21.03	H
5639.93	-35.17	13.10	17.11	-39.18	-13.00	-26.18	H
7520.05	-33.51	11.50	22.20	-44.21	-13.00	-31.21	H
3759.87	-35.88	12.60	12.93	-36.21	-13.00	-23.21	V
5639.93	-34.54	13.10	17.11	-38.55	-13.00	-25.55	V
7520.05	-32.35	11.50	22.20	-43.05	-13.00	-30.05	V
The Worst Test Results for Channel 810/1909.8MHz							
Frequency(MHz)	S	Ant(dBi)	Loss	PMea	Limit	Margin	Polarity
	G.Lev (dBm)			(dBm)	(dBm)	(dBm)	
3819.39	-34.01	12.60	12.93	-34.34	-13.00	-21.34	H
5729.51	-35.09	13.10	17.11	-39.10	-13.00	-26.10	H
7639.02	-33.13	11.50	22.20	-43.83	-13.00	-30.83	H
3819.39	-35.92	12.60	12.93	-36.25	-13.00	-23.25	V
5729.51	-34.93	13.10	17.11	-38.94	-13.00	-25.94	V
7639.02	-32.75	11.50	22.20	-43.45	-13.00	-30.45	V



LTE Band 2 / 1.4MHz / QPSK / RB Size 1 Offset 0/ The Worst Test Results for Lowest							
Frequency(MHz)	S G.Lev (dBm)	Ant(dBi)	Loss	PMea	Limit	Margin	Polarity
				(dBm)	(dBm)	(dBm)	
3701.04	-34.10	12.60	12.93	-34.43	-13.00	-21.43	H
5551.73	-34.88	13.10	17.11	-38.89	-13.00	-25.89	H
7402.49	-33.31	11.50	22.20	-44.01	-13.00	-31.01	H
3701.04	-35.92	12.60	12.93	-36.25	-13.00	-23.25	V
5551.73	-34.64	13.10	17.11	-38.65	-13.00	-25.65	V
7402.49	-31.71	11.50	22.20	-42.41	-13.00	-29.41	V
LTE Band 2 / 1.4MHz / QPSK / RB Size 1 Offset 0/ The Worst Test Results for Middle							
Frequency(MHz)	S G.Lev (dBm)	Ant(dBi)	Loss	PMea	Limit	Margin	Polarity
				(dBm)	(dBm)	(dBm)	
3760.14	-34.79	12.60	12.93	-35.12	-13.00	-22.12	H
5639.96	-33.99	13.10	17.11	-38.00	-13.00	-25.00	H
7520.00	-33.50	11.50	22.20	-44.20	-13.00	-31.20	H
3760.14	-35.58	12.60	12.93	-35.91	-13.00	-22.91	V
5639.96	-34.96	13.10	17.11	-38.97	-13.00	-25.97	V
7520.00	-31.95	11.50	22.20	-42.65	-13.00	-29.65	V
LTE Band 2 / 1.4MHz / QPSK / RB Size 1 Offset 0/ The Worst Test Results for Highest							
Frequency(MHz)	S G.Lev (dBm)	Ant(dBi)	Loss	PMea	Limit	Margin	Polarity
				(dBm)	(dBm)	(dBm)	
3818.29	-34.11	12.60	12.93	-34.44	-13.00	-21.44	H
5727.82	-34.74	13.10	17.11	-38.75	-13.00	-25.75	H
7637.10	-33.23	11.50	22.20	-43.93	-13.00	-30.93	H
3818.29	-35.77	12.60	12.93	-36.10	-13.00	-23.10	V
5727.82	-34.25	13.10	17.11	-38.26	-13.00	-25.26	V
7637.10	-32.94	11.50	22.20	-43.64	-13.00	-30.64	V



LTE Band 2 / 3MHz / QPSK / RB Size 1 Offset 0/ The Worst Test Results for Lowest							
Frequency(MHz)	S G.Lev (dBm)	Ant(dBi)	Loss	PMea	Limit	Margin	Polarity
				(dBm)	(dBm)	(dBm)	
3702.87	-34.09	12.60	12.93	-34.42	-13.00	-21.42	H
5554.55	-34.12	13.10	17.11	-38.13	-13.00	-25.13	H
7405.80	-32.17	11.50	22.20	-42.87	-13.00	-29.87	H
3702.87	-34.74	12.60	12.93	-35.07	-13.00	-22.07	V
5554.55	-35.18	13.10	17.11	-39.19	-13.00	-26.19	V
7405.80	-32.37	11.50	22.20	-43.07	-13.00	-30.07	V
LTE Band 2 / 3MHz / QPSK / RB Size 1 Offset 0/ The Worst Test Results for Middle							
Frequency(MHz)	S G.Lev (dBm)	Ant(dBi)	Loss	PMea	Limit	Margin	Polarity
				(dBm)	(dBm)	(dBm)	
3759.89	-34.54	12.60	12.93	-34.87	-13.00	-21.87	H
5640.13	-35.16	13.10	17.11	-39.17	-13.00	-26.17	H
7520.08	-33.12	11.50	22.20	-43.82	-13.00	-30.82	H
3759.89	-35.24	12.60	12.93	-35.57	-13.00	-22.57	V
5640.13	-34.51	13.10	17.11	-38.52	-13.00	-25.52	V
7520.08	-32.40	11.50	22.20	-43.10	-13.00	-30.10	V
LTE Band 2 / 3MHz / QPSK / RB Size 1 Offset 0/ The Worst Test Results for Highest							
Frequency(MHz)	S G.Lev (dBm)	Ant(dBi)	Loss	PMea	Limit	Margin	Polarity
				(dBm)	(dBm)	(dBm)	
3817.14	-33.48	12.60	12.93	-33.81	-13.00	-20.81	H
5725.70	-35.18	13.10	17.11	-39.19	-13.00	-26.19	H
7634.26	-32.22	11.50	22.20	-42.92	-13.00	-29.92	H
3817.14	-35.58	12.60	12.93	-35.91	-13.00	-22.91	V
5725.70	-34.42	13.10	17.11	-38.43	-13.00	-25.43	V
7634.26	-33.03	11.50	22.20	-43.73	-13.00	-30.73	V



LTE Band 2 / 5MHz / QPSK / RB Size 1 Offset 0/ The Worst Test Results for Lowest							
Frequency(MHz)	S G.Lev (dBm)	Ant(dBi)	Loss	PMea	Limit	Margin	Polarity
				(dBm)	(dBm)	(dBm)	
3705.05	-34.41	12.60	12.93	-34.74	-13.00	-21.74	H
5557.17	-34.94	13.10	17.11	-38.95	-13.00	-25.95	H
7409.92	-32.22	11.50	22.20	-42.92	-13.00	-29.92	H
3705.05	-34.64	12.60	12.93	-34.97	-13.00	-21.97	V
5557.17	-35.07	13.10	17.11	-39.08	-13.00	-26.08	V
7409.92	-31.95	11.50	22.20	-42.65	-13.00	-29.65	V
LTE Band 2 / 5MHz / QPSK / RB Size 1 Offset 0/ The Worst Test Results for Middle							
Frequency(MHz)	S G.Lev (dBm)	Ant(dBi)	Loss	PMea	Limit	Margin	Polarity
				(dBm)	(dBm)	(dBm)	
3760.00	-34.49	12.60	12.93	-34.82	-13.00	-21.82	H
5640.05	-34.71	13.10	17.11	-38.72	-13.00	-25.72	H
7520.25	-32.25	11.50	22.20	-42.95	-13.00	-29.95	H
3760.00	-35.22	12.60	12.93	-35.55	-13.00	-22.55	V
5640.05	-34.12	13.10	17.11	-38.13	-13.00	-25.13	V
7520.25	-32.90	11.50	22.20	-43.60	-13.00	-30.60	V
LTE Band 2 / 5MHz / QPSK / RB Size 1 Offset 0/ The Worst Test Results for Highest							
Frequency(MHz)	S G.Lev (dBm)	Ant(dBi)	Loss	PMea	Limit	Margin	Polarity
				(dBm)	(dBm)	(dBm)	
3815.18	-34.03	12.60	12.93	-34.36	-13.00	-21.36	H
5722.41	-35.31	13.10	17.11	-39.32	-13.00	-26.32	H
7630.11	-32.89	11.50	22.20	-43.59	-13.00	-30.59	H
3815.18	-35.40	12.60	12.93	-35.73	-13.00	-22.73	V
5722.41	-33.84	13.10	17.11	-37.85	-13.00	-24.85	V
7630.11	-31.99	11.50	22.20	-42.69	-13.00	-29.69	V



LTE Band 2 / 10MHz / QPSK / RB Size 1 Offset 0/ The Worst Test Results for Lowest							
Frequency(MHz)	S G.Lev (dBm)	Ant(dBi)	Loss	PMea	Limit	Margin	Polarity
				(dBm)	(dBm)	(dBm)	
3710.02	-34.92	12.60	12.93	-35.25	-13.00	-22.25	H
5564.99	-35.32	13.10	17.11	-39.33	-13.00	-26.33	H
7420.06	-32.81	11.50	22.20	-43.51	-13.00	-30.51	H
3710.02	-35.61	12.60	12.93	-35.94	-13.00	-22.94	V
5564.99	-33.94	13.10	17.11	-37.95	-13.00	-24.95	V
7420.06	-31.93	11.50	22.20	-42.63	-13.00	-29.63	V
LTE Band 2 / 10MHz / QPSK / RB Size 1 Offset 0/ The Worst Test Results for Middle							
Frequency(MHz)	S G.Lev (dBm)	Ant(dBi)	Loss	PMea	Limit	Margin	Polarity
				(dBm)	(dBm)	(dBm)	
3759.97	-33.70	12.60	12.93	-34.03	-13.00	-21.03	H
5640.09	-34.17	13.10	17.11	-38.18	-13.00	-25.18	H
7520.25	-33.48	11.50	22.20	-44.18	-13.00	-31.18	H
3759.97	-35.32	12.60	12.93	-35.65	-13.00	-22.65	V
5640.09	-34.72	13.10	17.11	-38.73	-13.00	-25.73	V
7520.25	-32.09	11.50	22.20	-42.79	-13.00	-29.79	V
LTE Band 2 / 10MHz / QPSK / RB Size 1 Offset 0/ The Worst Test Results for Highest							
Frequency(MHz)	S G.Lev (dBm)	Ant(dBi)	Loss	PMea	Limit	Margin	Polarity
				(dBm)	(dBm)	(dBm)	
3810.15	-33.59	12.60	12.93	-33.92	-13.00	-20.92	H
5715.09	-35.42	13.10	17.11	-39.43	-13.00	-26.43	H
7619.88	-32.97	11.50	22.20	-43.67	-13.00	-30.67	H
3810.15	-35.25	12.60	12.93	-35.58	-13.00	-22.58	V
5715.09	-33.92	13.10	17.11	-37.93	-13.00	-24.93	V
7619.88	-33.19	11.50	22.20	-43.89	-13.00	-30.89	V



LTE Band 2 / 15MHz / QPSK / RB Size 1 Offset 0/ The Worst Test Results for Lowest							
Frequency(MHz)	S G.Lev (dBm)	Ant(dBi)	Loss	PMea	Limit	Margin	Polarity
				(dBm)	(dBm)	(dBm)	
3715.15	-34.94	12.60	12.93	-35.27	-13.00	-22.27	H
5572.16	-35.46	13.10	17.11	-39.47	-13.00	-26.47	H
7430.60	-33.20	11.50	22.20	-43.90	-13.00	-30.90	H
3715.15	-34.76	12.60	12.93	-35.09	-13.00	-22.09	V
5572.16	-34.54	13.10	17.11	-38.55	-13.00	-25.55	V
7430.60	-32.70	11.50	22.20	-43.40	-13.00	-30.40	V
LTE Band 2 / 15MHz / QPSK / RB Size 1 Offset 0/ The Worst Test Results for Middle							
Frequency(MHz)	S G.Lev (dBm)	Ant(dBi)	Loss	PMea	Limit	Margin	Polarity
				(dBm)	(dBm)	(dBm)	
3760.18	-34.00	12.60	12.93	-34.33	-13.00	-21.33	H
5640.24	-34.17	13.10	17.11	-38.18	-13.00	-25.18	H
7520.28	-32.27	11.50	22.20	-42.97	-13.00	-29.97	H
3760.18	-34.58	12.60	12.93	-34.91	-13.00	-21.91	V
5640.24	-33.99	13.10	17.11	-38.00	-13.00	-25.00	V
7520.28	-32.83	11.50	22.20	-43.53	-13.00	-30.53	V
LTE Band 2 / 15MHz / QPSK / RB Size 1 Offset 0/ The Worst Test Results for Highest							
Frequency(MHz)	S G.Lev (dBm)	Ant(dBi)	Loss	PMea	Limit	Margin	Polarity
				(dBm)	(dBm)	(dBm)	
3805.00	-33.85	12.60	12.93	-34.18	-13.00	-21.18	H
5707.41	-34.83	13.10	17.11	-38.84	-13.00	-25.84	H
7610.26	-33.13	11.50	22.20	-43.83	-13.00	-30.83	H
3805.00	-34.87	12.60	12.93	-35.20	-13.00	-22.20	V
5707.41	-34.45	13.10	17.11	-38.46	-13.00	-25.46	V
7610.26	-31.82	11.50	22.20	-42.52	-13.00	-29.52	V



LTE Band 2 / 20MHz / QPSK / RB Size 1 Offset 0/ The Worst Test Results for Lowest							
Frequency(MHz)	S G.Lev (dBm)	Ant(dBi)	Loss	PMea	Limit	Margin	Polarity
				(dBm)	(dBm)	(dBm)	
3720.18	-34.05	12.60	12.93	-34.38	-13.00	-21.38	H
5580.46	-34.86	13.10	17.11	-38.87	-13.00	-25.87	H
7439.69	-33.44	11.50	22.20	-44.14	-13.00	-31.14	H
3720.18	-35.70	12.60	12.93	-36.03	-13.00	-23.03	V
5580.46	-34.13	13.10	17.11	-38.14	-13.00	-25.14	V
7439.69	-33.04	11.50	22.20	-43.74	-13.00	-30.74	V
LTE Band 2 / 20MHz / QPSK / RB Size 1 Offset 0/ The Worst Test Results for Middle							
Frequency(MHz)	S G.Lev (dBm)	Ant(dBi)	Loss	PMea	Limit	Margin	Polarity
				(dBm)	(dBm)	(dBm)	
3760.08	-33.45	12.60	12.93	-33.78	-13.00	-20.78	H
5640.05	-35.26	13.10	17.11	-39.27	-13.00	-26.27	H
7519.89	-32.33	11.50	22.20	-43.03	-13.00	-30.03	H
3760.08	-35.48	12.60	12.93	-35.81	-13.00	-22.81	V
5640.05	-33.92	13.10	17.11	-37.93	-13.00	-24.93	V
7519.89	-31.76	11.50	22.20	-42.46	-13.00	-29.46	V
LTE Band 2 / 20MHz / QPSK / RB Size 1 Offset 0/ The Worst Test Results for Highest							
Frequency(MHz)	S G.Lev (dBm)	Ant(dBi)	Loss	PMea	Limit	Margin	Polarity
				(dBm)	(dBm)	(dBm)	
3799.93	-34.83	12.60	12.93	-35.16	-13.00	-22.16	H
5699.84	-34.03	13.10	17.11	-38.04	-13.00	-25.04	H
7600.10	-32.22	11.50	22.20	-42.92	-13.00	-29.92	H
3799.93	-35.11	12.60	12.93	-35.44	-13.00	-22.44	V
5699.84	-34.45	13.10	17.11	-38.46	-13.00	-25.46	V
7600.10	-32.33	11.50	22.20	-43.03	-13.00	-30.03	V



LTE Band 4 / 1.4MHz / QPSK / RB Size 1 Offset 0/ The Worst Test Results for Lowest							
Frequency(MHz)	S G.Lev (dBm)	Ant(dBi)	Loss	PMea	Limit	Margin	Polarity
				(dBm)	(dBm)	(dBm)	
3420.88	-34.44	12.90	12.56	-34.10	-13.00	-21.10	H
5131.85	-35.38	13.10	16.32	-38.60	-13.00	-25.60	H
6842.48	-33.16	12.33	21.13	-41.96	-13.00	-28.96	H
3420.88	-34.64	12.90	12.56	-34.30	-13.00	-21.30	V
5131.85	-35.15	13.10	16.32	-38.37	-13.00	-25.37	V
6842.48	-32.64	12.33	21.13	-41.44	-13.00	-28.44	V
LTE Band 4 / 1.4MHz / QPSK / RB Size 1 Offset 0/ The Worst Test Results for Middle							
Frequency(MHz)	S G.Lev (dBm)	Ant(dBi)	Loss	PMea	Limit	Margin	Polarity
				(dBm)	(dBm)	(dBm)	
3464.99	-33.68	12.90	12.56	-33.34	-13.00	-20.34	H
5196.93	-34.14	13.10	16.32	-37.36	-13.00	-24.36	H
6929.79	-32.84	12.33	21.13	-41.64	-13.00	-28.64	H
3464.99	-35.68	12.90	12.56	-35.34	-13.00	-22.34	V
5196.93	-34.97	13.10	16.32	-38.19	-13.00	-25.19	V
6929.79	-32.74	12.33	21.13	-41.54	-13.00	-28.54	V
LTE Band 4 / 1.4MHz / QPSK / RB Size 1 Offset 0/ The Worst Test Results for Highest							
Frequency(MHz)	S G.Lev (dBm)	Ant(dBi)	Loss	PMea	Limit	Margin	Polarity
				(dBm)	(dBm)	(dBm)	
3508.49	-34.32	12.90	12.56	-33.98	-13.00	-20.98	H
5262.57	-34.90	13.10	16.32	-38.12	-13.00	-25.12	H
7015.71	-32.16	12.33	21.13	-40.96	-13.00	-27.96	H
3508.49	-34.87	12.90	12.56	-34.53	-13.00	-21.53	V
5262.57	-34.38	13.10	16.32	-37.60	-13.00	-24.60	V
7015.71	-32.43	12.33	21.13	-41.23	-13.00	-28.23	V



LTE Band 4 / 3MHz / QPSK / RB Size 1 Offset 0/ The Worst Test Results for Lowest							
Frequency(MHz)	S G.Lev (dBm)	Ant(dBi)	Loss	PMea	Limit	Margin	Polarity
				(dBm)	(dBm)	(dBm)	
3423.74	-34.43	12.90	12.56	-34.09	-13.00	-21.09	H
5135.94	-34.25	13.10	16.32	-37.47	-13.00	-24.47	H
6848.66	-32.38	12.33	21.13	-41.18	-13.00	-28.18	H
3423.74	-36.00	12.90	12.56	-35.66	-13.00	-22.66	V
5135.94	-35.02	13.10	16.32	-38.24	-13.00	-25.24	V
6848.66	-33.04	12.33	21.13	-41.84	-13.00	-28.84	V
LTE Band 4 / 3MHz / QPSK / RB Size 1 Offset 0/ The Worst Test Results for Middle							
Frequency(MHz)	S G.Lev (dBm)	Ant(dBi)	Loss	PMea	Limit	Margin	Polarity
				(dBm)	(dBm)	(dBm)	
3464.90	-34.05	12.90	12.56	-33.71	-13.00	-20.71	H
5196.66	-34.73	13.10	16.32	-37.95	-13.00	-24.95	H
6930.16	-32.74	12.33	21.13	-41.54	-13.00	-28.54	H
3464.90	-34.90	12.90	12.56	-34.56	-13.00	-21.56	V
5196.66	-34.13	13.10	16.32	-37.35	-13.00	-24.35	V
6930.16	-32.16	12.33	21.13	-40.96	-13.00	-27.96	V
LTE Band 4 / 3MHz / QPSK / RB Size 1 Offset 0/ The Worst Test Results for Highest							
Frequency(MHz)	S G.Lev (dBm)	Ant(dBi)	Loss	PMea	Limit	Margin	Polarity
				(dBm)	(dBm)	(dBm)	
3506.32	-34.41	12.90	12.56	-34.07	-13.00	-21.07	H
5261.63	-34.99	13.10	16.32	-38.21	-13.00	-25.21	H
7012.38	-32.20	12.33	21.13	-41.00	-13.00	-28.00	H
3506.32	-35.03	12.90	12.56	-34.69	-13.00	-21.69	V
5261.63	-34.51	13.10	16.32	-37.73	-13.00	-24.73	V
7012.38	-32.22	12.33	21.13	-41.02	-13.00	-28.02	V



LTE Band 4 / 5MHz / QPSK / RB Size 1 Offset 0/ The Worst Test Results for Lowest							
Frequency(MHz)	S G.Lev (dBm)	Ant(dBi)	Loss	PMea	Limit	Margin	Polarity
				(dBm)	(dBm)	(dBm)	
3424.88	-33.96	12.90	12.56	-33.62	-13.00	-20.62	H
5137.23	-34.91	13.10	16.32	-38.13	-13.00	-25.13	H
6849.82	-32.38	12.33	21.13	-41.18	-13.00	-28.18	H
3424.88	-35.92	12.90	12.56	-35.58	-13.00	-22.58	V
5137.23	-34.98	13.10	16.32	-38.20	-13.00	-25.20	V
6849.82	-31.75	12.33	21.13	-40.55	-13.00	-27.55	V
LTE Band 4 / 5MHz / QPSK / RB Size 1 Offset 0/ The Worst Test Results for Middle							
Frequency(MHz)	S G.Lev (dBm)	Ant(dBi)	Loss	PMea	Limit	Margin	Polarity
				(dBm)	(dBm)	(dBm)	
3464.65	-34.55	12.90	12.56	-34.21	-13.00	-21.21	H
5196.98	-35.10	13.10	16.32	-38.32	-13.00	-25.32	H
6929.86	-33.03	12.33	21.13	-41.83	-13.00	-28.83	H
3464.65	-35.87	12.90	12.56	-35.53	-13.00	-22.53	V
5196.98	-34.52	13.10	16.32	-37.74	-13.00	-24.74	V
6929.86	-32.79	12.33	21.13	-41.59	-13.00	-28.59	V
LTE Band 4 / 5MHz / QPSK / RB Size 1 Offset 0/ The Worst Test Results for Highest							
Frequency(MHz)	S G.Lev (dBm)	Ant(dBi)	Loss	PMea	Limit	Margin	Polarity
				(dBm)	(dBm)	(dBm)	
3505.05	-33.70	12.90	12.56	-33.36	-13.00	-20.36	H
5256.99	-34.14	13.10	16.32	-37.36	-13.00	-24.36	H
7009.83	-32.90	12.33	21.13	-41.70	-13.00	-28.70	H
3505.05	-34.94	12.90	12.56	-34.60	-13.00	-21.60	V
5256.99	-35.06	13.10	16.32	-38.28	-13.00	-25.28	V
7009.83	-31.82	12.33	21.13	-40.62	-13.00	-27.62	V



LTE Band 4 / 10MHz / QPSK / RB Size 1 Offset 0/ The Worst Test Results for Lowest							
Frequency(MHz)	S G.Lev (dBm)	Ant(dBi)	Loss	PMea	Limit	Margin	Polarity
				(dBm)	(dBm)	(dBm)	
3429.85	-34.58	12.90	12.56	-34.24	-13.00	-21.24	H
5144.99	-35.41	13.10	16.32	-38.63	-13.00	-25.63	H
6860.25	-32.80	12.33	21.13	-41.60	-13.00	-28.60	H
3429.85	-35.47	12.90	12.56	-35.13	-13.00	-22.13	V
5144.99	-34.08	13.10	16.32	-37.30	-13.00	-24.30	V
6860.25	-31.78	12.33	21.13	-40.58	-13.00	-27.58	V
LTE Band 4 / 10MHz / QPSK / RB Size 1 Offset 0/ The Worst Test Results for Middle							
Frequency(MHz)	S G.Lev (dBm)	Ant(dBi)	Loss	PMea	Limit	Margin	Polarity
				(dBm)	(dBm)	(dBm)	
3464.42	-34.93	12.90	12.56	-34.59	-13.00	-21.59	H
5196.71	-34.16	13.10	16.32	-37.38	-13.00	-24.38	H
6929.78	-32.29	12.33	21.13	-41.09	-13.00	-28.09	H
3464.42	-35.69	12.90	12.56	-35.35	-13.00	-22.35	V
5196.71	-35.11	13.10	16.32	-38.33	-13.00	-25.33	V
6929.78	-33.18	12.33	21.13	-41.98	-13.00	-28.98	V
LTE Band 4 / 10MHz / QPSK / RB Size 1 Offset 0/ The Worst Test Results for Highest							
Frequency(MHz)	S G.Lev (dBm)	Ant(dBi)	Loss	PMea	Limit	Margin	Polarity
				(dBm)	(dBm)	(dBm)	
3500.36	-33.58	12.90	12.56	-33.24	-13.00	-20.24	H
5250.40	-34.87	13.10	16.32	-38.09	-13.00	-25.09	H
6999.99	-32.70	12.33	21.13	-41.50	-13.00	-28.50	H
3500.36	-35.62	12.90	12.56	-35.28	-13.00	-22.28	V
5250.40	-34.02	13.10	16.32	-37.24	-13.00	-24.24	V
6999.99	-32.15	12.33	21.13	-40.95	-13.00	-27.95	V



LTE Band 4 / 15MHz / QPSK / RB Size 1 Offset 0/ The Worst Test Results for Lowest							
Frequency(MHz)	S G.Lev (dBm)	Ant(dBi)	Loss	PMea	Limit	Margin	Polarity
				(dBm)	(dBm)	(dBm)	
3434.81	-33.78	12.90	12.56	-33.44	-13.00	-20.44	H
5152.16	-35.42	13.10	16.32	-38.64	-13.00	-25.64	H
6870.35	-32.97	12.33	21.13	-41.77	-13.00	-28.77	H
3434.81	-34.85	12.90	12.56	-34.51	-13.00	-21.51	V
5152.16	-35.10	13.10	16.32	-38.32	-13.00	-25.32	V
6870.35	-32.07	12.33	21.13	-40.87	-13.00	-27.87	V
LTE Band 4 / 15MHz / QPSK / RB Size 1 Offset 0/ The Worst Test Results for Middle							
Frequency(MHz)	S G.Lev (dBm)	Ant(dBi)	Loss	PMea	Limit	Margin	Polarity
				(dBm)	(dBm)	(dBm)	
3464.77	-34.02	12.90	12.56	-33.68	-13.00	-20.68	H
5196.71	-35.14	13.10	16.32	-38.36	-13.00	-25.36	H
6930.02	-32.16	12.33	21.13	-40.96	-13.00	-27.96	H
3464.77	-35.77	12.90	12.56	-35.43	-13.00	-22.43	V
5196.71	-35.17	13.10	16.32	-38.39	-13.00	-25.39	V
6930.02	-32.50	12.33	21.13	-41.30	-13.00	-28.30	V
LTE Band 4 / 15MHz / QPSK / RB Size 1 Offset 0/ The Worst Test Results for Highest							
Frequency(MHz)	S G.Lev (dBm)	Ant(dBi)	Loss	PMea	Limit	Margin	Polarity
				(dBm)	(dBm)	(dBm)	
3495.23	-34.39	12.90	12.56	-34.05	-13.00	-21.05	H
5242.33	-35.11	13.10	16.32	-38.33	-13.00	-25.33	H
6990.10	-33.24	12.33	21.13	-42.04	-13.00	-29.04	H
3495.23	-35.72	12.90	12.56	-35.38	-13.00	-22.38	V
5242.33	-34.37	13.10	16.32	-37.59	-13.00	-24.59	V
6990.10	-32.81	12.33	21.13	-41.61	-13.00	-28.61	V



LTE Band 4 / 20MHz / QPSK / RB Size 1 Offset 0/ The Worst Test Results for Lowest							
Frequency(MHz)	S G.Lev (dBm)	Ant(dBi)	Loss	PMea	Limit	Margin	Polarity
				(dBm)	(dBm)	(dBm)	
3440.15	-33.97	12.90	12.56	-33.63	-13.00	-20.63	H
5160.34	-35.04	13.10	16.32	-38.26	-13.00	-25.26	H
6880.42	-33.11	12.33	21.13	-41.91	-13.00	-28.91	H
3440.15	-34.57	12.90	12.56	-34.23	-13.00	-21.23	V
5160.34	-34.63	13.10	16.32	-37.85	-13.00	-24.85	V
6880.42	-32.21	12.33	21.13	-41.01	-13.00	-28.01	V
LTE Band 4 / 20MHz / QPSK / RB Size 1 Offset 0/ The Worst Test Results for Middle							
Frequency(MHz)	S G.Lev (dBm)	Ant(dBi)	Loss	PMea	Limit	Margin	Polarity
				(dBm)	(dBm)	(dBm)	
3465.02	-33.58	12.90	12.56	-33.24	-13.00	-20.24	H
5196.70	-34.89	13.10	16.32	-38.11	-13.00	-25.11	H
6929.74	-33.00	12.33	21.13	-41.80	-13.00	-28.80	H
3465.02	-35.61	12.90	12.56	-35.27	-13.00	-22.27	V
5196.70	-34.65	13.10	16.32	-37.87	-13.00	-24.87	V
6929.74	-33.11	12.33	21.13	-41.91	-13.00	-28.91	V
LTE Band 4 / 20MHz / QPSK / RB Size 1 Offset 0/ The Worst Test Results for Highest							
Frequency(MHz)	S G.Lev (dBm)	Ant(dBi)	Loss	PMea	Limit	Margin	Polarity
				(dBm)	(dBm)	(dBm)	
3490.63	-34.15	12.90	12.56	-33.81	-13.00	-20.81	H
5234.96	-34.94	13.10	16.32	-38.16	-13.00	-25.16	H
6979.74	-33.44	12.33	21.13	-42.24	-13.00	-29.24	H
3490.63	-35.85	12.90	12.56	-35.51	-13.00	-22.51	V
5234.96	-34.20	13.10	16.32	-37.42	-13.00	-24.42	V
6979.74	-32.74	12.33	21.13	-41.54	-13.00	-28.54	V



LTE Band 5 / 1.4MHz / QPSK / RB Size 1 Offset 0/ The Worst Test Results for Lowest							
Frequency(MHz)	S G.Lev (dBm)	Ant(dBi)	Loss	PMea	Limit	Margin	Polarity
				(dBm)	(dBm)	(dBm)	
1648.92	-33.77	9.56	9.72	-33.93	-13.00	-20.93	H
2473.81	-34.16	10.50	10.86	-34.52	-13.00	-21.52	H
3298.42	-33.65	12.78	11.57	-32.44	-13.00	-19.44	H
1648.92	-35.61	9.56	9.72	-35.77	-13.00	-22.77	V
2473.81	-35.24	10.50	10.86	-35.60	-13.00	-22.60	V
3298.42	-32.12	12.78	11.57	-30.91	-13.00	-17.91	V
LTE Band 5 / 1.4MHz / QPSK / RB Size 1 Offset 0/ The Worst Test Results for Middle							
Frequency(MHz)	S G.Lev (dBm)	Ant(dBi)	Loss	PMea	Limit	Margin	Polarity
				(dBm)	(dBm)	(dBm)	
1672.66	-33.56	9.56	9.72	-33.72	-13.00	-20.72	H
2508.98	-35.17	10.50	10.86	-35.53	-13.00	-22.53	H
3345.72	-32.80	12.78	11.57	-31.59	-13.00	-18.59	H
1672.66	-35.75	9.56	9.72	-35.91	-13.00	-22.91	V
2508.98	-33.98	10.50	10.86	-34.34	-13.00	-21.34	V
3345.72	-32.01	12.78	11.57	-30.80	-13.00	-17.80	V
LTE Band 5 / 1.4MHz / QPSK / RB Size 1 Offset 0/ The Worst Test Results for Highest							
Frequency(MHz)	S G.Lev (dBm)	Ant(dBi)	Loss	PMea	Limit	Margin	Polarity
				(dBm)	(dBm)	(dBm)	
1696.26	-34.45	9.56	9.72	-34.61	-13.00	-21.61	H
2544.31	-34.17	10.50	10.86	-34.53	-13.00	-21.53	H
3392.80	-33.15	12.78	11.57	-31.94	-13.00	-18.94	H
1696.26	-35.89	9.56	9.72	-36.05	-13.00	-23.05	V
2544.31	-34.28	10.50	10.86	-34.64	-13.00	-21.64	V
3392.80	-31.85	12.78	11.57	-30.64	-13.00	-17.64	V



LTE Band 5 / 3MHz / QPSK / RB Size 1 Offset 0/ The Worst Test Results for Lowest							
Frequency(MHz)	S G.Lev (dBm)	Ant(dBi)	Loss	PMea	Limit	Margin	Polarity
				(dBm)	(dBm)	(dBm)	
1650.28	-34.82	9.56	9.72	-34.98	-13.00	-21.98	H
2475.73	-34.94	10.50	10.86	-35.30	-13.00	-22.30	H
3301.42	-32.89	12.78	11.57	-31.68	-13.00	-18.68	H
1650.28	-34.97	9.56	9.72	-35.13	-13.00	-22.13	V
2475.73	-34.08	10.50	10.86	-34.44	-13.00	-21.44	V
3301.42	-32.99	12.78	11.57	-31.78	-13.00	-18.78	V
LTE Band 5 / 3MHz / QPSK / RB Size 1 Offset 0/ The Worst Test Results for Middle							
Frequency(MHz)	S G.Lev (dBm)	Ant(dBi)	Loss	PMea	Limit	Margin	Polarity
				(dBm)	(dBm)	(dBm)	
1672.44	-34.19	9.56	9.72	-34.35	-13.00	-21.35	H
2508.74	-34.66	10.50	10.86	-35.02	-13.00	-22.02	H
3345.59	-33.53	12.78	11.57	-32.32	-13.00	-19.32	H
1672.44	-34.90	9.56	9.72	-35.06	-13.00	-22.06	V
2508.74	-33.79	10.50	10.86	-34.15	-13.00	-21.15	V
3345.59	-32.94	12.78	11.57	-31.73	-13.00	-18.73	V
LTE Band 5 / 3MHz / QPSK / RB Size 1 Offset 0/ The Worst Test Results for Highest							
Frequency(MHz)	S G.Lev (dBm)	Ant(dBi)	Loss	PMea	Limit	Margin	Polarity
				(dBm)	(dBm)	(dBm)	
1694.53	-33.63	9.56	9.72	-33.79	-13.00	-20.79	H
2542.06	-35.25	10.50	10.86	-35.61	-13.00	-22.61	H
3389.21	-32.98	12.78	11.57	-31.77	-13.00	-18.77	H
1694.53	-34.55	9.56	9.72	-34.71	-13.00	-21.71	V
2542.06	-34.76	10.50	10.86	-35.12	-13.00	-22.12	V
3389.21	-32.15	12.78	11.57	-30.94	-13.00	-17.94	V



LTE Band 5 / 5MHz / QPSK / RB Size 1 Offset 0/ The Worst Test Results for Lowest							
Frequency(MHz)	S G.Lev (dBm)	Ant(dBi)	Loss	PMea	Limit	Margin	Polarity
				(dBm)	(dBm)	(dBm)	
1652.68	-34.77	9.56	9.72	-34.93	-13.00	-21.93	H
2478.94	-34.60	10.50	10.86	-34.96	-13.00	-21.96	H
3305.49	-32.79	12.78	11.57	-31.58	-13.00	-18.58	H
1652.68	-35.23	9.56	9.72	-35.39	-13.00	-22.39	V
2478.94	-34.70	10.50	10.86	-35.06	-13.00	-22.06	V
3305.49	-32.38	12.78	11.57	-31.17	-13.00	-18.17	V
LTE Band 5 / 5MHz / QPSK / RB Size 1 Offset 0/ The Worst Test Results for Middle							
Frequency(MHz)	S G.Lev (dBm)	Ant(dBi)	Loss	PMea	Limit	Margin	Polarity
				(dBm)	(dBm)	(dBm)	
1672.14	-34.86	9.56	9.72	-35.02	-13.00	-22.02	H
2508.59	-34.99	10.50	10.86	-35.35	-13.00	-22.35	H
3345.38	-32.79	12.78	11.57	-31.58	-13.00	-18.58	H
1672.14	-35.35	9.56	9.72	-35.51	-13.00	-22.51	V
2508.59	-34.03	10.50	10.86	-34.39	-13.00	-21.39	V
3345.38	-32.74	12.78	11.57	-31.53	-13.00	-18.53	V
LTE Band 5 / 5MHz / QPSK / RB Size 1 Offset 0/ The Worst Test Results for Highest							
Frequency(MHz)	S G.Lev (dBm)	Ant(dBi)	Loss	PMea	Limit	Margin	Polarity
				(dBm)	(dBm)	(dBm)	
1692.29	-34.84	9.56	9.72	-35.00	-13.00	-22.00	H
2538.71	-34.78	10.50	10.86	-35.14	-13.00	-22.14	H
3385.77	-33.44	12.78	11.57	-32.23	-13.00	-19.23	H
1692.29	-35.73	9.56	9.72	-35.89	-13.00	-22.89	V
2538.71	-34.46	10.50	10.86	-34.82	-13.00	-21.82	V
3385.77	-33.08	12.78	11.57	-31.87	-13.00	-18.87	V



LTE Band 5 / 10MHz / QPSK / RB Size 1 Offset 0/ The Worst Test Results for Lowest							
Frequency(MHz)	S G.Lev (dBm)	Ant(dBi)	Loss	PMea	Limit	Margin	Polarity
				(dBm)	(dBm)	(dBm)	
1657.60	-34.54	9.56	9.72	-34.70	-13.00	-21.70	H
2486.19	-34.71	10.50	10.86	-35.07	-13.00	-22.07	H
3315.30	-32.37	12.78	11.57	-31.16	-13.00	-18.16	H
1657.60	-35.86	9.56	9.72	-36.02	-13.00	-23.02	V
2486.19	-34.20	10.50	10.86	-34.56	-13.00	-21.56	V
3315.30	-32.12	12.78	11.57	-30.91	-13.00	-17.91	V
LTE Band 5 / 10MHz / QPSK / RB Size 1 Offset 0/ The Worst Test Results for Middle							
Frequency(MHz)	S G.Lev (dBm)	Ant(dBi)	Loss	PMea	Limit	Margin	Polarity
				(dBm)	(dBm)	(dBm)	
1672.56	-33.85	9.56	9.72	-34.01	-13.00	-21.01	H
2508.89	-34.33	10.50	10.86	-34.69	-13.00	-21.69	H
3345.16	-32.60	12.78	11.57	-31.39	-13.00	-18.39	H
1672.56	-35.42	9.56	9.72	-35.58	-13.00	-22.58	V
2508.89	-34.04	10.50	10.86	-34.40	-13.00	-21.40	V
3345.16	-32.05	12.78	11.57	-30.84	-13.00	-17.84	V
LTE Band 5 / 10MHz / QPSK / RB Size 1 Offset 0/ The Worst Test Results for Highest							
Frequency(MHz)	S G.Lev (dBm)	Ant(dBi)	Loss	PMea	Limit	Margin	Polarity
				(dBm)	(dBm)	(dBm)	
1687.64	-34.81	9.56	9.72	-34.97	-13.00	-21.97	H
2531.45	-35.25	10.50	10.86	-35.61	-13.00	-22.61	H
3375.66	-32.28	12.78	11.57	-31.07	-13.00	-18.07	H
1687.64	-35.31	9.56	9.72	-35.47	-13.00	-22.47	V
2531.45	-33.89	10.50	10.86	-34.25	-13.00	-21.25	V
3375.66	-32.35	12.78	11.57	-31.14	-13.00	-18.14	V



LTE Band 12 / 1.4MHz / QPSK / RB Size 1 Offset 0/ The Worst Test Results for Lowest							
Frequency(MHz)	S G.Lev (dBm)	Ant(dBi)	Loss	PMea	Limit	Margin	Polarity
				(dBm)	(dBm)	(dBm)	
1398.93	-34.63	8.17	9.34	-35.80	-13.00	-22.80	H
2098.62	-34.57	9.53	10.42	-35.46	-13.00	-22.46	H
2798.68	-33.36	11.27	11.12	-33.21	-13.00	-20.21	H
1398.93	-34.87	8.17	9.34	-36.04	-13.00	-23.04	V
2098.62	-34.63	9.53	10.42	-35.52	-13.00	-22.52	V
2798.68	-32.39	11.27	11.12	-32.24	-13.00	-19.24	V
LTE Band 12 / 1.4MHz / QPSK / RB Size 1 Offset 0/ The Worst Test Results for Middle							
Frequency(MHz)	S G.Lev (dBm)	Ant(dBi)	Loss	PMea	Limit	Margin	Polarity
				(dBm)	(dBm)	(dBm)	
1414.98	-34.93	8.17	9.34	-36.10	-13.00	-23.10	H
2122.40	-35.23	9.53	10.42	-36.12	-13.00	-23.12	H
2829.61	-33.59	11.27	11.12	-33.44	-13.00	-20.44	H
1414.98	-35.68	8.17	9.34	-36.85	-13.00	-23.85	V
2122.40	-34.54	9.53	10.42	-35.43	-13.00	-22.43	V
2829.61	-31.80	11.27	11.12	-31.65	-13.00	-18.65	V
LTE Band 12 / 1.4MHz / QPSK / RB Size 1 Offset 0/ The Worst Test Results for Highest							
Frequency(MHz)	S G.Lev (dBm)	Ant(dBi)	Loss	PMea	Limit	Margin	Polarity
				(dBm)	(dBm)	(dBm)	
1430.33	-34.03	8.17	9.34	-35.20	-13.00	-22.20	H
2145.89	-34.64	9.53	10.42	-35.53	-13.00	-22.53	H
2860.84	-32.64	11.27	11.12	-32.49	-13.00	-19.49	H
1430.33	-36.00	8.17	9.34	-37.17	-13.00	-24.17	V
2145.89	-34.78	9.53	10.42	-35.67	-13.00	-22.67	V
2860.84	-32.69	11.27	11.12	-32.54	-13.00	-19.54	V



LTE Band 12 / 3MHz / QPSK / RB Size 1 Offset 0/ The Worst Test Results for Lowest							
Frequency(MHz)	S G.Lev (dBm)	Ant(dBi)	Loss	PMea	Limit	Margin	Polarity
				(dBm)	(dBm)	(dBm)	
1400.79	-34.36	8.17	9.34	-35.53	-13.00	-22.53	H
2101.25	-35.26	9.53	10.42	-36.15	-13.00	-23.15	H
2801.60	-33.23	11.27	11.12	-33.08	-13.00	-20.08	H
1400.79	-35.04	8.17	9.34	-36.21	-13.00	-23.21	V
2101.25	-34.37	9.53	10.42	-35.26	-13.00	-22.26	V
2801.60	-32.15	11.27	11.12	-32.00	-13.00	-19.00	V
LTE Band 12 / 3MHz / QPSK / RB Size 1 Offset 0/ The Worst Test Results for Middle							
Frequency(MHz)	S G.Lev (dBm)	Ant(dBi)	Loss	PMea	Limit	Margin	Polarity
				(dBm)	(dBm)	(dBm)	
1414.55	-34.18	8.17	9.34	-35.35	-13.00	-22.35	H
2122.45	-35.19	9.53	10.42	-36.08	-13.00	-23.08	H
2829.78	-32.54	11.27	11.12	-32.39	-13.00	-19.39	H
1414.55	-36.00	8.17	9.34	-37.17	-13.00	-24.17	V
2122.45	-35.19	9.53	10.42	-36.08	-13.00	-23.08	V
2829.78	-32.32	11.27	11.12	-32.17	-13.00	-19.17	V
LTE Band 12 / 3MHz / QPSK / RB Size 1 Offset 0/ The Worst Test Results for Highest							
Frequency(MHz)	S G.Lev (dBm)	Ant(dBi)	Loss	PMea	Limit	Margin	Polarity
				(dBm)	(dBm)	(dBm)	
1428.98	-34.38	8.17	9.34	-35.55	-13.00	-22.55	H
2143.08	-35.43	9.53	10.42	-36.32	-13.00	-23.32	H
2857.54	-32.71	11.27	11.12	-32.56	-13.00	-19.56	H
1428.98	-34.53	8.17	9.34	-35.70	-13.00	-22.70	V
2143.08	-34.56	9.53	10.42	-35.45	-13.00	-22.45	V
2857.54	-32.82	11.27	11.12	-32.67	-13.00	-19.67	V



LTE Band 12 / 5MHz / QPSK / RB Size 1 Offset 0/ The Worst Test Results for Lowest							
Frequency(MHz)	S G.Lev (dBm)	Ant(dBi)	Loss	PMea	Limit	Margin	Polarity
				(dBm)	(dBm)	(dBm)	
1402.71	-34.09	8.17	9.34	-35.26	-13.00	-22.26	H
2104.42	-34.50	9.53	10.42	-35.39	-13.00	-22.39	H
2805.87	-32.84	11.27	11.12	-32.69	-13.00	-19.69	H
1402.71	-35.06	8.17	9.34	-36.23	-13.00	-23.23	V
2104.42	-34.58	9.53	10.42	-35.47	-13.00	-22.47	V
2805.87	-31.79	11.27	11.12	-31.64	-13.00	-18.64	V
LTE Band 12 / 5MHz / QPSK / RB Size 1 Offset 0/ The Worst Test Results for Middle							
Frequency(MHz)	S G.Lev (dBm)	Ant(dBi)	Loss	PMea	Limit	Margin	Polarity
				(dBm)	(dBm)	(dBm)	
1414.96	-34.72	8.17	9.34	-35.89	-13.00	-22.89	H
2122.14	-34.02	9.53	10.42	-34.91	-13.00	-21.91	H
2829.88	-32.19	11.27	11.12	-32.04	-13.00	-19.04	H
1414.96	-35.13	8.17	9.34	-36.30	-13.00	-23.30	V
2122.14	-34.73	9.53	10.42	-35.62	-13.00	-22.62	V
2829.88	-33.07	11.27	11.12	-32.92	-13.00	-19.92	V
LTE Band 12 / 5MHz / QPSK / RB Size 1 Offset 0/ The Worst Test Results for Highest							
Frequency(MHz)	S G.Lev (dBm)	Ant(dBi)	Loss	PMea	Limit	Margin	Polarity
				(dBm)	(dBm)	(dBm)	
1426.82	-33.55	8.17	9.34	-34.72	-13.00	-21.72	H
2140.33	-34.15	9.53	10.42	-35.04	-13.00	-22.04	H
2853.71	-32.81	11.27	11.12	-32.66	-13.00	-19.66	H
1426.82	-35.75	8.17	9.34	-36.92	-13.00	-23.92	V
2140.33	-34.96	9.53	10.42	-35.85	-13.00	-22.85	V
2853.71	-31.99	11.27	11.12	-31.84	-13.00	-18.84	V



LTE Band 12 / 10MHz / QPSK / RB Size 1 Offset 0/ The Worst Test Results for Lowest							
Frequency(MHz)	S G.Lev (dBm)	Ant(dBi)	Loss	PMea	Limit	Margin	Polarity
				(dBm)	(dBm)	(dBm)	
1407.79	-33.97	8.17	9.34	-35.14	-13.00	-22.14	H
2111.77	-34.60	9.53	10.42	-35.49	-13.00	-22.49	H
2815.80	-32.23	11.27	11.12	-32.08	-13.00	-19.08	H
1407.79	-35.50	8.17	9.34	-36.67	-13.00	-23.67	V
2111.77	-33.77	9.53	10.42	-34.66	-13.00	-21.66	V
2815.80	-32.10	11.27	11.12	-31.95	-13.00	-18.95	V
LTE Band 12 / 10MHz / QPSK / RB Size 1 Offset 0/ The Worst Test Results for Middle							
Frequency(MHz)	S G.Lev (dBm)	Ant(dBi)	Loss	PMea	Limit	Margin	Polarity
				(dBm)	(dBm)	(dBm)	
1414.54	-34.34	8.17	9.34	-35.51	-13.00	-22.51	H
2122.08	-34.71	9.53	10.42	-35.60	-13.00	-22.60	H
2829.91	-33.28	11.27	11.12	-33.13	-13.00	-20.13	H
1414.54	-34.61	8.17	9.34	-35.78	-13.00	-22.78	V
2122.08	-34.93	9.53	10.42	-35.82	-13.00	-22.82	V
2829.91	-32.21	11.27	11.12	-32.06	-13.00	-19.06	V
LTE Band 12 / 10MHz / QPSK / RB Size 1 Offset 0/ The Worst Test Results for Highest							
Frequency(MHz)	S G.Lev (dBm)	Ant(dBi)	Loss	PMea	Limit	Margin	Polarity
				(dBm)	(dBm)	(dBm)	
1421.71	-34.55	8.17	9.34	-35.72	-13.00	-22.72	H
2132.68	-34.08	9.53	10.42	-34.97	-13.00	-21.97	H
2843.51	-33.24	11.27	11.12	-33.09	-13.00	-20.09	H
1421.71	-34.62	8.17	9.34	-35.79	-13.00	-22.79	V
2132.68	-35.16	9.53	10.42	-36.05	-13.00	-23.05	V
2843.51	-32.61	11.27	11.12	-32.46	-13.00	-19.46	V



LTE Band 13 / 5MHz / QPSK / RB Size 1 Offset 0/ The Worst Test Results for Lowest							
Frequency(MHz)	S G.Lev (dBm)	Ant(dBi)	Loss	PMea	Limit	Margin	Polarity
				(dBm)	(dBm)	(dBm)	
1559.46	-47.60	9.56	9.72	-47.76	-40.00	-7.76	H
2338.14	-47.05	10.50	10.86	-47.41	-13.00	-34.41	H
3118.30	-45.55	12.78	11.57	-44.34	-13.00	-31.34	H
1559.46	-48.69	9.56	9.72	-48.85	-40.00	-8.85	V
2338.14	-46.33	10.50	10.86	-46.69	-13.00	-33.69	V
3118.30	-46.14	12.78	11.57	-44.93	-13.00	-31.93	V

LTE Band 13 / 5MHz / QPSK / RB Size 1 Offset 0/ The Worst Test Results for Middle							
Frequency(MHz)	S G.Lev (dBm)	Ant(dBi)	Loss	PMea	Limit	Margin	Polarity
				(dBm)	(dBm)	(dBm)	
1564.37	-48.42	9.56	9.72	-48.58	-40.00	-8.58	H
2346.09	-46.99	10.50	10.86	-47.35	-13.00	-34.35	H
3127.86	-45.66	12.78	11.57	-44.45	-13.00	-31.45	H
1564.37	-48.77	9.56	9.72	-48.93	-40.00	-8.93	V
2346.09	-47.45	10.50	10.86	-47.81	-13.00	-34.81	V
3127.86	-45.26	12.78	11.57	-44.05	-13.00	-31.05	V

LTE Band 13 / 5MHz / QPSK / RB Size 1 Offset 0/ The Worst Test Results for Highest							
Frequency(MHz)	S G.Lev (dBm)	Ant(dBi)	Loss	PMea	Limit	Margin	Polarity
				(dBm)	(dBm)	(dBm)	
1568.84	-48.44	9.56	9.72	-48.60	-40.00	-8.60	H
2353.49	-47.10	10.50	10.86	-47.46	-13.00	-34.46	H
3138.16	-46.45	12.78	11.57	-45.24	-13.00	-32.24	H
1568.84	-47.55	9.56	9.72	-47.71	-40.00	-7.71	V
2353.49	-46.29	10.50	10.86	-46.65	-13.00	-33.65	V
3138.16	-46.46	12.78	11.57	-45.25	-13.00	-32.25	V

LTE Band 13 / 10MHz / QPSK / RB Size 1 Offset 0/ The Worst Test Results for Middle							
Frequency(MHz)	S G.Lev (dBm)	Ant(dBi)	Loss	PMea	Limit	Margin	Polarity
				(dBm)	(dBm)	(dBm)	
1564.16	-47.72	9.56	9.72	-47.88	-40.00	-7.88	H
2345.83	-46.67	10.50	10.86	-47.03	-13.00	-34.03	H
3127.95	-45.96	12.78	11.57	-44.75	-13.00	-31.75	H
1564.16	-47.48	9.56	9.72	-47.64	-40.00	-7.64	V
2345.83	-47.09	10.50	10.86	-47.45	-13.00	-34.45	V
3127.95	-46.39	12.78	11.57	-45.18	-13.00	-32.18	V



LTE Band 25 / 1.4MHz / QPSK / RB Size 1 Offset 0/ The Worst Test Results for Lowest							
Frequency(MHz)	S G.Lev (dBm)	Ant(dBi)	Loss	PMea	Limit	Margin	Polarity
				(dBm)	(dBm)	(dBm)	
3701.14	-34.69	12.60	12.93	-35.02	-13.00	-22.02	H
5552.01	-35.11	13.10	17.11	-39.12	-13.00	-26.12	H
7402.80	-33.24	11.50	22.20	-43.94	-13.00	-30.94	H
3701.14	-34.65	12.60	12.93	-34.98	-13.00	-21.98	V
5552.01	-34.22	13.10	17.11	-38.23	-13.00	-25.23	V
7402.80	-32.77	11.50	22.20	-43.47	-13.00	-30.47	V
LTE Band 25 / 1.4MHz / QPSK / RB Size 1 Offset 0/ The Worst Test Results for Middle							
Frequency(MHz)	S G.Lev (dBm)	Ant(dBi)	Loss	PMea	Limit	Margin	Polarity
				(dBm)	(dBm)	(dBm)	
3760.19	-34.72	12.60	12.93	-35.05	-13.00	-22.05	H
5639.86	-34.42	13.10	17.11	-38.43	-13.00	-25.43	H
7519.89	-32.53	11.50	22.20	-43.23	-13.00	-30.23	H
3760.19	-35.82	12.60	12.93	-36.15	-13.00	-23.15	V
5639.86	-34.20	13.10	17.11	-38.21	-13.00	-25.21	V
7519.89	-32.00	11.50	22.20	-42.70	-13.00	-29.70	V
LTE Band 25 / 1.4MHz / QPSK / RB Size 1 Offset 0/ The Worst Test Results for Highest							
Frequency(MHz)	S G.Lev (dBm)	Ant(dBi)	Loss	PMea	Limit	Margin	Polarity
				(dBm)	(dBm)	(dBm)	
3818.53	-34.45	12.60	12.93	-34.78	-13.00	-21.78	H
5727.82	-34.04	13.10	17.11	-38.05	-13.00	-25.05	H
7637.16	-33.40	11.50	22.20	-44.10	-13.00	-31.10	H
3818.53	-34.90	12.60	12.93	-35.23	-13.00	-22.23	V
5727.82	-33.83	13.10	17.11	-37.84	-13.00	-24.84	V
7637.16	-32.33	11.50	22.20	-43.03	-13.00	-30.03	V



LTE Band 25 / 3MHz / QPSK / RB Size 1 Offset 0/ The Worst Test Results for Lowest							
Frequency(MHz)	S G.Lev (dBm)	Ant(dBi)	Loss	PMea	Limit	Margin	Polarity
				(dBm)	(dBm)	(dBm)	
3703.10	-34.78	12.60	12.93	-35.11	-13.00	-22.11	H
5554.16	-34.51	13.10	17.11	-38.52	-13.00	-25.52	H
7405.68	-33.61	11.50	22.20	-44.31	-13.00	-31.31	H
3703.10	-35.12	12.60	12.93	-35.45	-13.00	-22.45	V
5554.16	-34.78	13.10	17.11	-38.79	-13.00	-25.79	V
7405.68	-31.78	11.50	22.20	-42.48	-13.00	-29.48	V
LTE Band 25 / 3MHz / QPSK / RB Size 1 Offset 0/ The Worst Test Results for Middle							
Frequency(MHz)	S G.Lev (dBm)	Ant(dBi)	Loss	PMea	Limit	Margin	Polarity
				(dBm)	(dBm)	(dBm)	
3760.03	-33.78	12.60	12.93	-34.11	-13.00	-21.11	H
5640.16	-34.89	13.10	17.11	-38.90	-13.00	-25.90	H
7519.89	-33.19	11.50	22.20	-43.89	-13.00	-30.89	H
3760.03	-34.78	12.60	12.93	-35.11	-13.00	-22.11	V
5640.16	-34.10	13.10	17.11	-38.11	-13.00	-25.11	V
7519.89	-31.96	11.50	22.20	-42.66	-13.00	-29.66	V
LTE Band 25 / 3MHz / QPSK / RB Size 1 Offset 0/ The Worst Test Results for Highest							
Frequency(MHz)	S G.Lev (dBm)	Ant(dBi)	Loss	PMea	Limit	Margin	Polarity
				(dBm)	(dBm)	(dBm)	
3816.88	-33.44	12.60	12.93	-33.77	-13.00	-20.77	H
5725.61	-34.07	13.10	17.11	-38.08	-13.00	-25.08	H
7634.15	-33.55	11.50	22.20	-44.25	-13.00	-31.25	H
3816.88	-34.58	12.60	12.93	-34.91	-13.00	-21.91	V
5725.61	-34.43	13.10	17.11	-38.44	-13.00	-25.44	V
7634.15	-33.01	11.50	22.20	-43.71	-13.00	-30.71	V



LTE Band 25 / 5MHz / QPSK / RB Size 1 Offset 0/ The Worst Test Results for Lowest							
Frequency(MHz)	S G.Lev (dBm)	Ant(dBi)	Loss	PMea	Limit	Margin	Polarity
				(dBm)	(dBm)	(dBm)	
3705.18	-33.75	12.60	12.93	-34.08	-13.00	-21.08	H
5557.52	-34.06	13.10	17.11	-38.07	-13.00	-25.07	H
7410.18	-33.48	11.50	22.20	-44.18	-13.00	-31.18	H
3705.18	-35.09	12.60	12.93	-35.42	-13.00	-22.42	V
5557.52	-34.12	13.10	17.11	-38.13	-13.00	-25.13	V
7410.18	-32.41	11.50	22.20	-43.11	-13.00	-30.11	V
LTE Band 25 / 5MHz / QPSK / RB Size 1 Offset 0/ The Worst Test Results for Middle							
Frequency(MHz)	S G.Lev (dBm)	Ant(dBi)	Loss	PMea	Limit	Margin	Polarity
				(dBm)	(dBm)	(dBm)	
3759.97	-34.92	12.60	12.93	-35.25	-13.00	-22.25	H
5640.14	-34.03	13.10	17.11	-38.04	-13.00	-25.04	H
7519.99	-32.25	11.50	22.20	-42.95	-13.00	-29.95	H
3759.97	-35.59	12.60	12.93	-35.92	-13.00	-22.92	V
5640.14	-35.01	13.10	17.11	-39.02	-13.00	-26.02	V
7519.99	-32.46	11.50	22.20	-43.16	-13.00	-30.16	V
LTE Band 25 / 5MHz / QPSK / RB Size 1 Offset 0/ The Worst Test Results for Highest							
Frequency(MHz)	S G.Lev (dBm)	Ant(dBi)	Loss	PMea	Limit	Margin	Polarity
				(dBm)	(dBm)	(dBm)	
3815.00	-34.32	12.60	12.93	-34.65	-13.00	-21.65	H
5722.20	-34.58	13.10	17.11	-38.59	-13.00	-25.59	H
7630.22	-32.85	11.50	22.20	-43.55	-13.00	-30.55	H
3815.00	-35.08	12.60	12.93	-35.41	-13.00	-22.41	V
5722.20	-34.26	13.10	17.11	-38.27	-13.00	-25.27	V
7630.22	-31.73	11.50	22.20	-42.43	-13.00	-29.43	V



LTE Band 25 / 10MHz / QPSK / RB Size 1 Offset 0/ The Worst Test Results for Lowest							
Frequency(MHz)	S G.Lev (dBm)	Ant(dBi)	Loss	PMea	Limit	Margin	Polarity
				(dBm)	(dBm)	(dBm)	
3710.31	-33.46	12.60	12.93	-33.79	-13.00	-20.79	H
5565.15	-35.39	13.10	17.11	-39.40	-13.00	-26.40	H
7419.91	-33.16	11.50	22.20	-43.86	-13.00	-30.86	H
3710.31	-35.54	12.60	12.93	-35.87	-13.00	-22.87	V
5565.15	-35.01	13.10	17.11	-39.02	-13.00	-26.02	V
7419.91	-31.86	11.50	22.20	-42.56	-13.00	-29.56	V
LTE Band 25 / 10MHz / QPSK / RB Size 1 Offset 0/ The Worst Test Results for Middle							
Frequency(MHz)	S G.Lev (dBm)	Ant(dBi)	Loss	PMea	Limit	Margin	Polarity
				(dBm)	(dBm)	(dBm)	
3759.91	-33.63	12.60	12.93	-33.96	-13.00	-20.96	H
5639.89	-34.99	13.10	17.11	-39.00	-13.00	-26.00	H
7520.16	-33.64	11.50	22.20	-44.34	-13.00	-31.34	H
3759.91	-35.02	12.60	12.93	-35.35	-13.00	-22.35	V
5639.89	-34.55	13.10	17.11	-38.56	-13.00	-25.56	V
7520.16	-32.99	11.50	22.20	-43.69	-13.00	-30.69	V
LTE Band 25 / 10MHz / QPSK / RB Size 1 Offset 0/ The Worst Test Results for Highest							
Frequency(MHz)	S G.Lev (dBm)	Ant(dBi)	Loss	PMea	Limit	Margin	Polarity
				(dBm)	(dBm)	(dBm)	
3809.94	-34.13	12.60	12.93	-34.46	-13.00	-21.46	H
5714.95	-35.39	13.10	17.11	-39.40	-13.00	-26.40	H
7620.17	-33.31	11.50	22.20	-44.01	-13.00	-31.01	H
3809.94	-35.77	12.60	12.93	-36.10	-13.00	-23.10	V
5714.95	-34.90	13.10	17.11	-38.91	-13.00	-25.91	V
7620.17	-32.32	11.50	22.20	-43.02	-13.00	-30.02	V



LTE Band 25 / 15MHz / QPSK / RB Size 1 Offset 0/ The Worst Test Results for Lowest							
Frequency(MHz)	S G.Lev (dBm)	Ant(dBi)	Loss	PMea	Limit	Margin	Polarity
				(dBm)	(dBm)	(dBm)	
3715.15	-34.86	12.60	12.93	-35.19	-13.00	-22.19	H
5572.43	-34.75	13.10	17.11	-38.76	-13.00	-25.76	H
7430.67	-32.69	11.50	22.20	-43.39	-13.00	-30.39	H
3715.15	-35.31	12.60	12.93	-35.64	-13.00	-22.64	V
5572.43	-35.23	13.10	17.11	-39.24	-13.00	-26.24	V
7430.67	-32.67	11.50	22.20	-43.37	-13.00	-30.37	V
LTE Band 25 / 15MHz / QPSK / RB Size 1 Offset 0/ The Worst Test Results for Middle							
Frequency(MHz)	S G.Lev (dBm)	Ant(dBi)	Loss	PMea	Limit	Margin	Polarity
				(dBm)	(dBm)	(dBm)	
3760.11	-34.62	12.60	12.93	-34.95	-13.00	-21.95	H
5639.97	-34.87	13.10	17.11	-38.88	-13.00	-25.88	H
7520.08	-32.23	11.50	22.20	-42.93	-13.00	-29.93	H
3760.11	-34.57	12.60	12.93	-34.90	-13.00	-21.90	V
5639.97	-34.68	13.10	17.11	-38.69	-13.00	-25.69	V
7520.08	-32.51	11.50	22.20	-43.21	-13.00	-30.21	V
LTE Band 25 / 15MHz / QPSK / RB Size 1 Offset 0/ The Worst Test Results for Highest							
Frequency(MHz)	S G.Lev (dBm)	Ant(dBi)	Loss	PMea	Limit	Margin	Polarity
				(dBm)	(dBm)	(dBm)	
3805.24	-34.25	12.60	12.93	-34.58	-13.00	-21.58	H
5707.35	-35.33	13.10	17.11	-39.34	-13.00	-26.34	H
7610.18	-32.39	11.50	22.20	-43.09	-13.00	-30.09	H
3805.24	-35.79	12.60	12.93	-36.12	-13.00	-23.12	V
5707.35	-33.96	13.10	17.11	-37.97	-13.00	-24.97	V
7610.18	-32.07	11.50	22.20	-42.77	-13.00	-29.77	V



LTE Band 25 / 20MHz / QPSK / RB Size 1 Offset 0/ The Worst Test Results for Lowest							
Frequency(MHz)	S G.Lev (dBm)	Ant(dBi)	Loss	PMea	Limit	Margin	Polarity
				(dBm)	(dBm)	(dBm)	
3720.15	-34.18	12.60	12.93	-34.51	-13.00	-21.51	H
5580.33	-35.34	13.10	17.11	-39.35	-13.00	-26.35	H
7439.85	-32.21	11.50	22.20	-42.91	-13.00	-29.91	H
3720.15	-35.01	12.60	12.93	-35.34	-13.00	-22.34	V
5580.33	-35.09	13.10	17.11	-39.10	-13.00	-26.10	V
7439.85	-32.66	11.50	22.20	-43.36	-13.00	-30.36	V
LTE Band 25 / 20MHz / QPSK / RB Size 1 Offset 0/ The Worst Test Results for Middle							
Frequency(MHz)	S G.Lev (dBm)	Ant(dBi)	Loss	PMea	Limit	Margin	Polarity
				(dBm)	(dBm)	(dBm)	
3760.13	-34.58	12.60	12.93	-34.91	-13.00	-21.91	H
5640.00	-34.47	13.10	17.11	-38.48	-13.00	-25.48	H
7520.10	-33.22	11.50	22.20	-43.92	-13.00	-30.92	H
3760.13	-35.55	12.60	12.93	-35.88	-13.00	-22.88	V
5640.00	-34.03	13.10	17.11	-38.04	-13.00	-25.04	V
7520.10	-31.94	11.50	22.20	-42.64	-13.00	-29.64	V
LTE Band 25 / 20MHz / QPSK / RB Size 1 Offset 0/ The Worst Test Results for Highest							
Frequency(MHz)	S G.Lev (dBm)	Ant(dBi)	Loss	PMea	Limit	Margin	Polarity
				(dBm)	(dBm)	(dBm)	
3800.12	-33.57	12.60	12.93	-33.90	-13.00	-20.90	H
5699.73	-34.38	13.10	17.11	-38.39	-13.00	-25.39	H
7600.16	-32.64	11.50	22.20	-43.34	-13.00	-30.34	H
3800.12	-35.50	12.60	12.93	-35.83	-13.00	-22.83	V
5699.73	-34.37	13.10	17.11	-38.38	-13.00	-25.38	V
7600.16	-33.13	11.50	22.20	-43.83	-13.00	-30.83	V



Part22

LTE Band 26 / 1.4MHz / QPSK / RB Size 1 Offset 0/ The Worst Test Results for Lowest							
Frequency(MHz)	S G.Lev (dBm)	Ant(dBi)	Loss	PMea	Limit	Margin	Polarity
				(dBm)	(dBm)	(dBm)	
1649.32	-33.96	9.56	9.72	-34.12	-13.00	-21.12	H
2473.23	-35.40	10.50	10.86	-35.76	-13.00	-22.76	H
3298.52	-33.12	12.78	11.57	-31.91	-13.00	-18.91	H
1649.32	-35.76	9.56	9.72	-35.92	-13.00	-22.92	V
2473.23	-34.78	10.50	10.86	-35.14	-13.00	-22.14	V
3298.52	-32.36	12.78	11.57	-31.15	-13.00	-18.15	V
LTE Band 26 / 1.4MHz / QPSK / RB Size 1 Offset 0/ The Worst Test Results for Middle							
Frequency(MHz)	S G.Lev (dBm)	Ant(dBi)	Loss	PMea	Limit	Margin	Polarity
				(dBm)	(dBm)	(dBm)	
1672.80	-34.23	9.56	9.72	-34.39	-13.00	-21.39	H
2509.01	-34.08	10.50	10.86	-34.44	-13.00	-21.44	H
3346.28	-33.46	12.78	11.57	-32.25	-13.00	-19.25	H
1672.80	-35.92	9.56	9.72	-36.08	-13.00	-23.08	V
2509.01	-34.21	10.50	10.86	-34.57	-13.00	-21.57	V
3346.28	-33.03	12.78	11.57	-31.82	-13.00	-18.82	V
LTE Band 26 / 1.4MHz / QPSK / RB Size 1 Offset 0/ The Worst Test Results for Highest							
Frequency(MHz)	S G.Lev (dBm)	Ant(dBi)	Loss	PMea	Limit	Margin	Polarity
				(dBm)	(dBm)	(dBm)	
1696.39	-34.78	9.56	9.72	-34.94	-13.00	-21.94	H
2544.45	-34.39	10.50	10.86	-34.75	-13.00	-21.75	H
3392.96	-33.37	12.78	11.57	-32.16	-13.00	-19.16	H
1696.39	-35.67	9.56	9.72	-35.83	-13.00	-22.83	V
2544.45	-34.45	10.50	10.86	-34.81	-13.00	-21.81	V
3392.96	-33.02	12.78	11.57	-31.81	-13.00	-18.81	V



LTE Band 26 / 3MHz / QPSK / RB Size 1 Offset 0/ The Worst Test Results for Lowest							
Frequency(MHz)	S G.Lev (dBm)	Ant(dBi)	Loss	PMea	Limit	Margin	Polarity
				(dBm)	(dBm)	(dBm)	
1651.45	-34.78	9.56	9.72	-34.94	-13.00	-21.94	H
2476.23	-34.01	10.50	10.86	-34.37	-13.00	-21.37	H
3301.66	-32.32	12.78	11.57	-31.11	-13.00	-18.11	H
1651.45	-34.70	9.56	9.72	-34.86	-13.00	-21.86	V
2476.23	-34.47	10.50	10.86	-34.83	-13.00	-21.83	V
3301.66	-33.07	12.78	11.57	-31.86	-13.00	-18.86	V
LTE Band 26 / 3MHz / QPSK / RB Size 1 Offset 0/ The Worst Test Results for Middle							
Frequency(MHz)	S G.Lev (dBm)	Ant(dBi)	Loss	PMea	Limit	Margin	Polarity
				(dBm)	(dBm)	(dBm)	
1673.03	-34.72	9.56	9.72	-34.88	-13.00	-21.88	H
2508.83	-34.73	10.50	10.86	-35.09	-13.00	-22.09	H
3346.26	-33.37	12.78	11.57	-32.16	-13.00	-19.16	H
1673.03	-34.80	9.56	9.72	-34.96	-13.00	-21.96	V
2508.83	-34.95	10.50	10.86	-35.31	-13.00	-22.31	V
3346.26	-32.46	12.78	11.57	-31.25	-13.00	-18.25	V
LTE Band 26 / 3MHz / QPSK / RB Size 1 Offset 0/ The Worst Test Results for Highest							
Frequency(MHz)	S G.Lev (dBm)	Ant(dBi)	Loss	PMea	Limit	Margin	Polarity
				(dBm)	(dBm)	(dBm)	
1695.59	-34.26	9.56	9.72	-34.42	-13.00	-21.42	H
2542.06	-34.11	10.50	10.86	-34.47	-13.00	-21.47	H
3390.30	-32.62	12.78	11.57	-31.41	-13.00	-18.41	H
1695.59	-35.33	9.56	9.72	-35.49	-13.00	-22.49	V
2542.06	-33.83	10.50	10.86	-34.19	-13.00	-21.19	V
3390.30	-31.91	12.78	11.57	-30.70	-13.00	-17.70	V



LTE Band 26 / 5MHz / QPSK / RB Size 1 Offset 0/ The Worst Test Results for Lowest							
Frequency(MHz)	S G.Lev (dBm)	Ant(dBi)	Loss	PMea	Limit	Margin	Polarity
				(dBm)	(dBm)	(dBm)	
1652.63	-34.16	9.56	9.72	-34.32	-13.00	-21.32	H
2479.37	-34.85	10.50	10.86	-35.21	-13.00	-22.21	H
3306.83	-32.70	12.78	11.57	-31.49	-13.00	-18.49	H
1652.63	-35.42	9.56	9.72	-35.58	-13.00	-22.58	V
2479.37	-33.83	10.50	10.86	-34.19	-13.00	-21.19	V
3306.83	-33.04	12.78	11.57	-31.83	-13.00	-18.83	V
LTE Band 26 / 5MHz / QPSK / RB Size 1 Offset 0/ The Worst Test Results for Middle							
Frequency(MHz)	S G.Lev (dBm)	Ant(dBi)	Loss	PMea	Limit	Margin	Polarity
				(dBm)	(dBm)	(dBm)	
1672.82	-33.83	9.56	9.72	-33.99	-13.00	-20.99	H
2508.84	-35.11	10.50	10.86	-35.47	-13.00	-22.47	H
3345.97	-33.07	12.78	11.57	-31.86	-13.00	-18.86	H
1672.82	-34.55	9.56	9.72	-34.71	-13.00	-21.71	V
2508.84	-34.28	10.50	10.86	-34.64	-13.00	-21.64	V
3345.97	-32.78	12.78	11.57	-31.57	-13.00	-18.57	V
LTE Band 26 / 5MHz / QPSK / RB Size 1 Offset 0/ The Worst Test Results for Highest							
Frequency(MHz)	S G.Lev (dBm)	Ant(dBi)	Loss	PMea	Limit	Margin	Polarity
				(dBm)	(dBm)	(dBm)	
1693.82	-34.12	9.56	9.72	-34.28	-13.00	-21.28	H
2539.28	-34.66	10.50	10.86	-35.02	-13.00	-22.02	H
3385.88	-33.20	12.78	11.57	-31.99	-13.00	-18.99	H
1693.82	-34.81	9.56	9.72	-34.97	-13.00	-21.97	V
2539.28	-35.04	10.50	10.86	-35.40	-13.00	-22.40	V
3385.88	-31.73	12.78	11.57	-30.52	-13.00	-17.52	V



LTE Band 26 / 10MHz / QPSK / RB Size 1 Offset 0/ The Worst Test Results for Lowest							
Frequency(MHz)	S G.Lev (dBm)	Ant(dBi)	Loss	PMea	Limit	Margin	Polarity
				(dBm)	(dBm)	(dBm)	
1658.18	-33.69	9.56	9.72	-33.85	-13.00	-20.85	H
2486.47	-34.26	10.50	10.86	-34.62	-13.00	-21.62	H
3315.94	-33.46	12.78	11.57	-32.25	-13.00	-19.25	H
1658.18	-34.74	9.56	9.72	-34.90	-13.00	-21.90	V
2486.47	-34.23	10.50	10.86	-34.59	-13.00	-21.59	V
3315.94	-32.64	12.78	11.57	-31.43	-13.00	-18.43	V
LTE Band 26 / 10MHz / QPSK / RB Size 1 Offset 0/ The Worst Test Results for Middle							
Frequency(MHz)	S G.Lev (dBm)	Ant(dBi)	Loss	PMea	Limit	Margin	Polarity
				(dBm)	(dBm)	(dBm)	
1672.90	-34.15	9.56	9.72	-34.31	-13.00	-21.31	H
2509.00	-34.04	10.50	10.86	-34.40	-13.00	-21.40	H
3346.11	-33.38	12.78	11.57	-32.17	-13.00	-19.17	H
1672.90	-34.78	9.56	9.72	-34.94	-13.00	-21.94	V
2509.00	-35.22	10.50	10.86	-35.58	-13.00	-22.58	V
3346.11	-32.01	12.78	11.57	-30.80	-13.00	-17.80	V
LTE Band 26 / 10MHz / QPSK / RB Size 1 Offset 0/ The Worst Test Results for Highest							
Frequency(MHz)	S G.Lev (dBm)	Ant(dBi)	Loss	PMea	Limit	Margin	Polarity
				(dBm)	(dBm)	(dBm)	
1688.80	-33.94	9.56	9.72	-34.10	-13.00	-21.10	H
2532.12	-34.84	10.50	10.86	-35.20	-13.00	-22.20	H
3376.07	-33.53	12.78	11.57	-32.32	-13.00	-19.32	H
1688.80	-34.78	9.56	9.72	-34.94	-13.00	-21.94	V
2532.12	-35.25	10.50	10.86	-35.61	-13.00	-22.61	V
3376.07	-31.80	12.78	11.57	-30.59	-13.00	-17.59	V



LTE Band 26 / 15MHz / QPSK / RB Size 1 Offset 0/ The Worst Test Results for Lowest							
Frequency(MHz)	S G.Lev (dBm)	Ant(dBi)	Loss	PMea	Limit	Margin	Polarity
				(dBm)	(dBm)	(dBm)	
1663.49	-34.31	9.56	9.72	-34.47	-13.00	-21.47	H
2494.45	-34.79	10.50	10.86	-35.15	-13.00	-22.15	H
3325.65	-32.49	12.78	11.57	-31.28	-13.00	-18.28	H
1663.49	-35.20	9.56	9.72	-35.36	-13.00	-22.36	V
2494.45	-33.75	10.50	10.86	-34.11	-13.00	-21.11	V
3325.65	-32.33	12.78	11.57	-31.12	-13.00	-18.12	V
LTE Band 26 / 15MHz / QPSK / RB Size 1 Offset 0/ The Worst Test Results for Middle							
Frequency(MHz)	S G.Lev (dBm)	Ant(dBi)	Loss	PMea	Limit	Margin	Polarity
				(dBm)	(dBm)	(dBm)	
1672.93	-34.80	9.56	9.72	-34.96	-13.00	-21.96	H
2508.87	-35.24	10.50	10.86	-35.60	-13.00	-22.60	H
3346.13	-32.97	12.78	11.57	-31.76	-13.00	-18.76	H
1672.93	-35.40	9.56	9.72	-35.56	-13.00	-22.56	V
2508.87	-34.55	10.50	10.86	-34.91	-13.00	-21.91	V
3346.13	-32.93	12.78	11.57	-31.72	-13.00	-18.72	V
LTE Band 26 / 15MHz / QPSK / RB Size 1 Offset 0/ The Worst Test Results for Highest							
Frequency(MHz)	S G.Lev (dBm)	Ant(dBi)	Loss	PMea	Limit	Margin	Polarity
				(dBm)	(dBm)	(dBm)	
1683.79	-34.12	9.56	9.72	-34.28	-13.00	-21.28	H
2524.09	-34.79	10.50	10.86	-35.15	-13.00	-22.15	H
3366.30	-32.67	12.78	11.57	-31.46	-13.00	-18.46	H
1683.79	-34.88	9.56	9.72	-35.04	-13.00	-22.04	V
2524.09	-34.52	10.50	10.86	-34.88	-13.00	-21.88	V
3366.30	-32.75	12.78	11.57	-31.54	-13.00	-18.54	V



Part90

LTE Band 26 / 1.4MHz / QPSK / RB Size 1 Offset 0/ The Worst Test Results for Lowest							
Frequency(MHz)	S G.Lev (dBm)	Ant(dBi)	Loss	PMea	Limit	Margin	Polarity
				(dBm)	(dBm)	(dBm)	
1629.36	-33.52	9.56	9.72	-33.68	-13.00	-20.68	H
2444.65	-34.40	10.50	10.86	-34.76	-13.00	-21.76	H
3258.59	-33.36	12.78	11.57	-32.15	-13.00	-19.15	H
1629.36	-35.29	9.56	9.72	-35.45	-13.00	-22.45	V
2444.65	-35.08	10.50	10.86	-35.44	-13.00	-22.44	V
3258.59	-32.53	12.78	11.57	-31.32	-13.00	-18.32	V
LTE Band 26 / 1.4MHz / QPSK / RB Size 1 Offset 0/ The Worst Test Results for Middle							
Frequency(MHz)	S G.Lev (dBm)	Ant(dBi)	Loss	PMea	Limit	Margin	Polarity
				(dBm)	(dBm)	(dBm)	
1637.93	-33.78	9.56	9.72	-33.94	-13.00	-20.94	H
2456.96	-34.67	10.50	10.86	-35.03	-13.00	-22.03	H
3275.95	-32.98	12.78	11.57	-31.77	-13.00	-18.77	H
1637.93	-35.22	9.56	9.72	-35.38	-13.00	-22.38	V
2456.96	-33.86	10.50	10.86	-34.22	-13.00	-21.22	V
3275.95	-32.18	12.78	11.57	-30.97	-13.00	-17.97	V
LTE Band 26 / 1.4MHz / QPSK / RB Size 1 Offset 0/ The Worst Test Results for Highest							
Frequency(MHz)	S G.Lev (dBm)	Ant(dBi)	Loss	PMea	Limit	Margin	Polarity
				(dBm)	(dBm)	(dBm)	
1646.38	-34.46	9.56	9.72	-34.62	-13.00	-21.62	H
2469.46	-34.38	10.50	10.86	-34.74	-13.00	-21.74	H
3293.17	-32.66	12.78	11.57	-31.45	-13.00	-18.45	H
1646.38	-35.14	9.56	9.72	-35.30	-13.00	-22.30	V
2469.46	-34.72	10.50	10.86	-35.08	-13.00	-22.08	V
3293.17	-32.51	12.78	11.57	-31.30	-13.00	-18.30	V



LTE Band 26 / 3MHz / QPSK / RB Size 1 Offset 0/ The Worst Test Results for Lowest							
Frequency(MHz)	S G.Lev (dBm)	Ant(dBi)	Loss	PMea	Limit	Margin	Polarity
				(dBm)	(dBm)	(dBm)	
1631.21	-34.11	9.56	9.72	-34.27	-13.00	-21.27	H
2446.31	-34.95	10.50	10.86	-35.31	-13.00	-22.31	H
3262.02	-33.17	12.78	11.57	-31.96	-13.00	-18.96	H
1631.21	-34.64	9.56	9.72	-34.80	-13.00	-21.80	V
2446.31	-34.16	10.50	10.86	-34.52	-13.00	-21.52	V
3262.02	-31.92	12.78	11.57	-30.71	-13.00	-17.71	V
LTE Band 26 / 3MHz / QPSK / RB Size 1 Offset 0/ The Worst Test Results for Middle							
Frequency(MHz)	S G.Lev (dBm)	Ant(dBi)	Loss	PMea	Limit	Margin	Polarity
				(dBm)	(dBm)	(dBm)	
1638.08	-33.80	9.56	9.72	-33.96	-13.00	-20.96	H
2456.82	-34.40	10.50	10.86	-34.76	-13.00	-21.76	H
3276.06	-32.37	12.78	11.57	-31.16	-13.00	-18.16	H
1638.08	-35.56	9.56	9.72	-35.72	-13.00	-22.72	V
2456.82	-35.23	10.50	10.86	-35.59	-13.00	-22.59	V
3276.06	-32.44	12.78	11.57	-31.23	-13.00	-18.23	V
LTE Band 26 / 3MHz / QPSK / RB Size 1 Offset 0/ The Worst Test Results for Highest							
Frequency(MHz)	S G.Lev (dBm)	Ant(dBi)	Loss	PMea	Limit	Margin	Polarity
				(dBm)	(dBm)	(dBm)	
1644.83	-34.48	9.56	9.72	-34.64	-13.00	-21.64	H
2467.34	-34.81	10.50	10.86	-35.17	-13.00	-22.17	H
3290.02	-32.96	12.78	11.57	-31.75	-13.00	-18.75	H
1644.83	-35.11	9.56	9.72	-35.27	-13.00	-22.27	V
2467.34	-33.93	10.50	10.86	-34.29	-13.00	-21.29	V
3290.02	-32.03	12.78	11.57	-30.82	-13.00	-17.82	V



LTE Band 26 / 5MHz / QPSK / RB Size 1 Offset 0/ The Worst Test Results for Lowest							
Frequency(MHz)	S G.Lev (dBm)	Ant(dBi)	Loss	PMea	Limit	Margin	Polarity
				(dBm)	(dBm)	(dBm)	
1632.83	-34.56	9.56	9.72	-34.72	-13.00	-21.72	H
2448.69	-35.23	10.50	10.86	-35.59	-13.00	-22.59	H
3265.97	-32.61	12.78	11.57	-31.40	-13.00	-18.40	H
1632.83	-34.87	9.56	9.72	-35.03	-13.00	-22.03	V
2448.69	-34.27	10.50	10.86	-34.63	-13.00	-21.63	V
3265.97	-32.27	12.78	11.57	-31.06	-13.00	-18.06	V

LTE Band 26 / 5MHz / QPSK / RB Size 1 Offset 0/ The Worst Test Results for Middle							
Frequency(MHz)	S G.Lev (dBm)	Ant(dBi)	Loss	PMea	Limit	Margin	Polarity
				(dBm)	(dBm)	(dBm)	
1643.24	-33.63	9.56	9.72	-33.79	-13.00	-20.79	H
2463.84	-35.45	10.50	10.86	-35.81	-13.00	-22.81	H
3286.11	-33.18	12.78	11.57	-31.97	-13.00	-18.97	H
1643.24	-34.84	9.56	9.72	-35.00	-13.00	-22.00	V
2463.84	-34.02	10.50	10.86	-34.38	-13.00	-21.38	V
3286.11	-32.29	12.78	11.57	-31.08	-13.00	-18.08	V

LTE Band 26 / 5MHz / QPSK / RB Size 1 Offset 0/ The Worst Test Results for Highest							
Frequency(MHz)	S G.Lev (dBm)	Ant(dBi)	Loss	PMea	Limit	Margin	Polarity
				(dBm)	(dBm)	(dBm)	
1693.63	-34.69	9.56	9.72	-34.85	-13.00	-21.85	H
2539.41	-35.16	10.50	10.86	-35.52	-13.00	-22.52	H
3385.84	-33.02	12.78	11.57	-31.81	-13.00	-18.81	H
1693.63	-35.99	9.56	9.72	-36.15	-13.00	-23.15	V
2539.41	-34.52	10.50	10.86	-34.88	-13.00	-21.88	V
3385.84	-32.93	12.78	11.57	-31.72	-13.00	-18.72	V

LTE Band 26 / 10MHz / QPSK / RB Size 1 Offset 0/ The Worst Test Results for Middle							
Frequency(MHz)	S G.Lev (dBm)	Ant(dBi)	Loss	PMea	Limit	Margin	Polarity
				(dBm)	(dBm)	(dBm)	
1638.14	-33.73	9.56	9.72	-33.89	-13.00	-20.89	H
2456.80	-34.63	10.50	10.86	-34.99	-13.00	-21.99	H
3276.27	-32.18	12.78	11.57	-30.97	-13.00	-17.97	H
1638.14	-34.97	9.56	9.72	-35.13	-13.00	-22.13	V
2456.80	-34.17	10.50	10.86	-34.53	-13.00	-21.53	V
3276.27	-32.80	12.78	11.57	-31.59	-13.00	-18.59	V



LTE Band 41 / 5MHz / QPSK / RB Size 1 Offset 0/ The Worst Test Results for Lowest							
Frequency(MHz)	S G.Lev (dBm)	Ant(dBi)	Loss	PMea	Limit	Margin	Polarity
				(dBm)	(dBm)	(dBm)	
4997.14	-33.89	12.66	15.86	-37.09	-25.00	-12.09	H
7495.67	-34.35	11.46	19.28	-42.17	-25.00	-17.17	H
9993.89	-33.55	12.79	23.19	-43.95	-25.00	-18.95	H
4997.14	-35.85	12.66	15.86	-39.05	-25.00	-14.05	V
7495.67	-33.84	11.46	19.28	-41.66	-25.00	-16.66	V
9993.89	-32.78	12.79	23.19	-43.18	-25.00	-18.18	V
LTE Band 41 / 5MHz / QPSK / RB Size 1 Offset 0/ The Worst Test Results for Middle							
Frequency(MHz)	S G.Lev (dBm)	Ant(dBi)	Loss	PMea	Limit	Margin	Polarity
				(dBm)	(dBm)	(dBm)	
5186.05	-34.73	12.72	15.86	-37.87	-25.00	-12.87	H
7779.33	-34.85	11.46	19.28	-42.67	-25.00	-17.67	H
10371.98	-33.45	12.09	23.19	-44.55	-25.00	-19.55	H
5186.05	-35.90	12.72	15.86	-39.04	-25.00	-14.04	V
7779.33	-35.10	11.46	19.28	-42.92	-25.00	-17.92	V
10371.98	-31.79	12.09	23.19	-42.89	-25.00	-17.89	V
LTE Band 41 / 5MHz / QPSK / RB Size 1 Offset 0/ The Worst Test Results for Highest							
Frequency(MHz)	S G.Lev (dBm)	Ant(dBi)	Loss	PMea	Limit	Margin	Polarity
				(dBm)	(dBm)	(dBm)	
5375.08	-34.48	12.76	15.86	-37.58	-25.00	-12.58	H
8062.75	-35.13	11.45	19.28	-42.96	-25.00	-17.96	H
10750.28	-32.78	12.28	23.19	-43.69	-25.00	-18.69	H
5375.08	-35.14	12.76	15.86	-38.24	-25.00	-13.24	V
8062.75	-35.06	11.45	19.28	-42.89	-25.00	-17.89	V
10750.28	-32.95	12.28	23.19	-43.86	-25.00	-18.86	V



LTE Band 41 / 10MHz / QPSK / RB Size 1 Offset 0/ The Worst Test Results for Lowest							
Frequency(MHz)	S G.Lev (dBm)	Ant(dBi)	Loss	PMea	Limit	Margin	Polarity
				(dBm)	(dBm)	(dBm)	
5002.20	-33.92	12.66	15.86	-37.12	-25.00	-12.12	H
7502.92	-34.83	11.46	19.28	-42.65	-25.00	-17.65	H
10003.86	-32.47	12.79	23.19	-42.87	-25.00	-17.87	H
5002.20	-34.74	12.66	15.86	-37.94	-25.00	-12.94	V
7502.92	-34.62	11.46	19.28	-42.44	-25.00	-17.44	V
10003.86	-33.18	12.79	23.19	-43.58	-25.00	-18.58	V
LTE Band 41 / 10MHz / QPSK / RB Size 1 Offset 0/ The Worst Test Results for Middle							
Frequency(MHz)	S G.Lev (dBm)	Ant(dBi)	Loss	PMea	Limit	Margin	Polarity
				(dBm)	(dBm)	(dBm)	
5186.26	-34.26	12.72	15.86	-37.40	-25.00	-12.40	H
7779.26	-34.94	11.46	19.28	-42.76	-25.00	-17.76	H
10371.91	-32.80	12.09	23.19	-43.90	-25.00	-18.90	H
5186.26	-36.02	12.72	15.86	-39.16	-25.00	-14.16	V
7779.26	-34.57	11.46	19.28	-42.39	-25.00	-17.39	V
10371.91	-33.02	12.09	23.19	-44.12	-25.00	-19.12	V
LTE Band 41 / 10MHz / QPSK / RB Size 1 Offset 0/ The Worst Test Results for Highest							
Frequency(MHz)	S G.Lev (dBm)	Ant(dBi)	Loss	PMea	Limit	Margin	Polarity
				(dBm)	(dBm)	(dBm)	
5370.28	-34.52	12.76	15.86	-37.62	-25.00	-12.62	H
8054.81	-34.29	11.45	19.28	-42.12	-25.00	-17.12	H
10739.98	-32.56	12.28	23.19	-43.47	-25.00	-18.47	H
5370.28	-35.71	12.76	15.86	-38.81	-25.00	-13.81	V
8054.81	-34.22	11.45	19.28	-42.05	-25.00	-17.05	V
10739.98	-32.89	12.28	23.19	-43.80	-25.00	-18.80	V



LTE Band 41 / 15MHz / QPSK / RB Size 1 Offset 0/ The Worst Test Results for Lowest							
Frequency(MHz)	S G.Lev (dBm)	Ant(dBi)	Loss	PMea	Limit	Margin	Polarity
				(dBm)	(dBm)	(dBm)	
5007.24	-34.62	12.66	15.86	-37.82	-25.00	-12.82	H
7510.44	-35.32	11.46	19.28	-43.14	-25.00	-18.14	H
10014.37	-33.06	12.79	23.19	-43.46	-25.00	-18.46	H
5007.24	-35.89	12.66	15.86	-39.09	-25.00	-14.09	V
7510.44	-34.00	11.46	19.28	-41.82	-25.00	-16.82	V
10014.37	-32.64	12.79	23.19	-43.04	-25.00	-18.04	V
LTE Band 41 / 15MHz / QPSK / RB Size 1 Offset 0/ The Worst Test Results for Middle							
Frequency(MHz)	S G.Lev (dBm)	Ant(dBi)	Loss	PMea	Limit	Margin	Polarity
				(dBm)	(dBm)	(dBm)	
5186.17	-34.75	12.72	15.86	-37.89	-25.00	-12.89	H
7779.16	-35.29	11.46	19.28	-43.11	-25.00	-18.11	H
10372.19	-33.18	12.09	23.19	-44.28	-25.00	-19.28	H
5186.17	-35.90	12.72	15.86	-39.04	-25.00	-14.04	V
7779.16	-34.76	11.46	19.28	-42.58	-25.00	-17.58	V
10372.19	-32.45	12.09	23.19	-43.55	-25.00	-18.55	V
LTE Band 41 / 15MHz / QPSK / RB Size 1 Offset 0/ The Worst Test Results for Highest							
Frequency(MHz)	S G.Lev (dBm)	Ant(dBi)	Loss	PMea	Limit	Margin	Polarity
				(dBm)	(dBm)	(dBm)	
5365.21	-34.08	12.76	15.86	-37.18	-25.00	-12.18	H
8047.80	-35.00	11.45	19.28	-42.83	-25.00	-17.83	H
10729.87	-32.94	12.28	23.19	-43.85	-25.00	-18.85	H
5365.21	-34.82	12.76	15.86	-37.92	-25.00	-12.92	V
8047.80	-34.78	11.45	19.28	-42.61	-25.00	-17.61	V
10729.87	-32.71	12.28	23.19	-43.62	-25.00	-18.62	V



LTE Band 41 / 20MHz / QPSK / RB Size 1 Offset 0/ The Worst Test Results for Lowest							
Frequency(MHz)	S G.Lev (dBm)	Ant(dBi)	Loss	PMea	Limit	Margin	Polarity
				(dBm)	(dBm)	(dBm)	
5011.94	-34.66	12.66	15.86	-37.86	-25.00	-12.86	H
7517.92	-34.75	11.46	19.28	-42.57	-25.00	-17.57	H
10023.94	-33.19	12.79	23.19	-43.59	-25.00	-18.59	H
5011.94	-35.88	12.66	15.86	-39.08	-25.00	-14.08	V
7517.92	-34.48	11.46	19.28	-42.30	-25.00	-17.30	V
10023.94	-32.19	12.79	23.19	-42.59	-25.00	-17.59	V
LTE Band 41 / 20MHz / QPSK / RB Size 1 Offset 0/ The Worst Test Results for Middle							
Frequency(MHz)	S G.Lev (dBm)	Ant(dBi)	Loss	PMea	Limit	Margin	Polarity
				(dBm)	(dBm)	(dBm)	
5185.91	-33.82	12.72	15.86	-36.96	-25.00	-11.96	H
7779.33	-34.66	11.46	19.28	-42.48	-25.00	-17.48	H
10372.21	-33.60	12.09	23.19	-44.70	-25.00	-19.70	H
5185.91	-35.97	12.72	15.86	-39.11	-25.00	-14.11	V
7779.33	-35.08	11.46	19.28	-42.90	-25.00	-17.90	V
10372.21	-32.39	12.09	23.19	-43.49	-25.00	-18.49	V
LTE Band 41 / 20MHz / QPSK / RB Size 1 Offset 0/ The Worst Test Results for Highest							
Frequency(MHz)	S G.Lev (dBm)	Ant(dBi)	Loss	PMea	Limit	Margin	Polarity
				(dBm)	(dBm)	(dBm)	
5359.79	-33.87	12.76	15.86	-36.97	-25.00	-11.97	H
8040.15	-34.30	11.45	19.28	-42.13	-25.00	-17.13	H
10720.08	-33.14	12.28	23.19	-44.05	-25.00	-19.05	H
5359.79	-34.79	12.76	15.86	-37.89	-25.00	-12.89	V
8040.15	-34.62	11.45	19.28	-42.45	-25.00	-17.45	V
10720.08	-31.89	12.28	23.19	-42.80	-25.00	-17.80	V



LTE Band 66 / 1.4MHz / QPSK / RB Size 1 Offset 0/ The Worst Test Results for Lowest							
Frequency(MHz)	S G.Lev (dBm)	Ant(dBi)	Loss	PMea	Limit	Margin	Polarity
				(dBm)	(dBm)	(dBm)	
3421.47	-34.63	12.90	12.56	-34.29	-13.00	-21.29	H
5132.18	-34.42	13.10	16.32	-37.64	-13.00	-24.64	H
6842.82	-32.47	12.33	21.13	-41.27	-13.00	-28.27	H
3421.47	-34.73	12.90	12.56	-34.39	-13.00	-21.39	V
5132.18	-35.10	13.10	16.32	-38.32	-13.00	-25.32	V
6842.82	-31.76	12.33	21.13	-40.56	-13.00	-27.56	V
LTE Band 66 / 1.4MHz / QPSK / RB Size 1 Offset 0/ The Worst Test Results for Middle							
Frequency(MHz)	S G.Lev (dBm)	Ant(dBi)	Loss	PMea	Limit	Margin	Polarity
				(dBm)	(dBm)	(dBm)	
3489.86	-34.13	12.90	12.56	-33.79	-13.00	-20.79	H
5235.10	-35.01	13.10	16.32	-38.23	-13.00	-25.23	H
6979.88	-33.15	12.33	21.13	-41.95	-13.00	-28.95	H
3489.86	-35.10	12.90	12.56	-34.76	-13.00	-21.76	V
5235.10	-33.88	13.10	16.32	-37.10	-13.00	-24.10	V
6979.88	-33.01	12.33	21.13	-41.81	-13.00	-28.81	V
LTE Band 66 / 1.4MHz / QPSK / RB Size 1 Offset 0/ The Worst Test Results for Highest							
Frequency(MHz)	S G.Lev (dBm)	Ant(dBi)	Loss	PMea	Limit	Margin	Polarity
				(dBm)	(dBm)	(dBm)	
3557.99	-33.49	12.90	12.56	-33.15	-13.00	-20.15	H
5337.19	-35.49	13.10	16.32	-38.71	-13.00	-25.71	H
7117.04	-33.11	12.33	21.13	-41.91	-13.00	-28.91	H
3557.99	-35.49	12.90	12.56	-35.15	-13.00	-22.15	V
5337.19	-35.06	13.10	16.32	-38.28	-13.00	-25.28	V
7117.04	-32.71	12.33	21.13	-41.51	-13.00	-28.51	V



LTE Band 66 / 3MHz / QPSK / RB Size 1 Offset 0/ The Worst Test Results for Lowest							
Frequency(MHz)	S G.Lev (dBm)	Ant(dBi)	Loss	PMea	Limit	Margin	Polarity
				(dBm)	(dBm)	(dBm)	
3422.99	-34.85	12.90	12.56	-34.51	-13.00	-21.51	H
5134.36	-34.24	13.10	16.32	-37.46	-13.00	-24.46	H
6846.26	-33.55	12.33	21.13	-42.35	-13.00	-29.35	H
3422.99	-35.57	12.90	12.56	-35.23	-13.00	-22.23	V
5134.36	-34.57	13.10	16.32	-37.79	-13.00	-24.79	V
6846.26	-33.09	12.33	21.13	-41.89	-13.00	-28.89	V
LTE Band 66 / 3MHz / QPSK / RB Size 1 Offset 0/ The Worst Test Results for Middle							
Frequency(MHz)	S G.Lev (dBm)	Ant(dBi)	Loss	PMea	Limit	Margin	Polarity
				(dBm)	(dBm)	(dBm)	
3490.06	-34.41	12.90	12.56	-34.07	-13.00	-21.07	H
5234.83	-34.57	13.10	16.32	-37.79	-13.00	-24.79	H
6980.04	-33.56	12.33	21.13	-42.36	-13.00	-29.36	H
3490.06	-35.95	12.90	12.56	-35.61	-13.00	-22.61	V
5234.83	-34.94	13.10	16.32	-38.16	-13.00	-25.16	V
6980.04	-32.56	12.33	21.13	-41.36	-13.00	-28.36	V
LTE Band 66 / 3MHz / QPSK / RB Size 1 Offset 0/ The Worst Test Results for Highest							
Frequency(MHz)	S G.Lev (dBm)	Ant(dBi)	Loss	PMea	Limit	Margin	Polarity
				(dBm)	(dBm)	(dBm)	
3557.20	-33.64	12.90	12.56	-33.30	-13.00	-20.30	H
5262.48	-33.99	13.10	16.32	-37.21	-13.00	-24.21	H
7113.96	-32.53	12.33	21.13	-41.33	-13.00	-28.33	H
3557.20	-35.39	12.90	12.56	-35.05	-13.00	-22.05	V
5262.48	-34.71	13.10	16.32	-37.93	-13.00	-24.93	V
7113.96	-33.06	12.33	21.13	-41.86	-13.00	-28.86	V



LTE Band 66 / 5MHz / QPSK / RB Size 1 Offset 0/ The Worst Test Results for Lowest							
Frequency(MHz)	S G.Lev (dBm)	Ant(dBi)	Loss	PMea	Limit	Margin	Polarity
				(dBm)	(dBm)	(dBm)	
3425.17	-33.91	12.90	12.56	-33.57	-13.00	-20.57	H
5137.41	-35.33	13.10	16.32	-38.55	-13.00	-25.55	H
6850.04	-33.41	12.33	21.13	-42.21	-13.00	-29.21	H
3425.17	-35.49	12.90	12.56	-35.15	-13.00	-22.15	V
5137.41	-34.85	13.10	16.32	-38.07	-13.00	-25.07	V
6850.04	-32.66	12.33	21.13	-41.46	-13.00	-28.46	V
LTE Band 66 / 5MHz / QPSK / RB Size 1 Offset 0/ The Worst Test Results for Middle							
Frequency(MHz)	S G.Lev (dBm)	Ant(dBi)	Loss	PMea	Limit	Margin	Polarity
				(dBm)	(dBm)	(dBm)	
3489.77	-34.52	12.90	12.56	-34.18	-13.00	-21.18	H
5235.28	-34.01	13.10	16.32	-37.23	-13.00	-24.23	H
6979.95	-33.29	12.33	21.13	-42.09	-13.00	-29.09	H
3489.77	-35.07	12.90	12.56	-34.73	-13.00	-21.73	V
5235.28	-33.80	13.10	16.32	-37.02	-13.00	-24.02	V
6979.95	-33.11	12.33	21.13	-41.91	-13.00	-28.91	V
LTE Band 66 / 5MHz / QPSK / RB Size 1 Offset 0/ The Worst Test Results for Highest							
Frequency(MHz)	S G.Lev (dBm)	Ant(dBi)	Loss	PMea	Limit	Margin	Polarity
				(dBm)	(dBm)	(dBm)	
3558.15	-34.42	12.90	12.56	-34.08	-13.00	-21.08	H
5234.76	-34.31	13.10	16.32	-37.53	-13.00	-24.53	H
7109.97	-32.31	12.33	21.13	-41.11	-13.00	-28.11	H
3558.15	-35.32	12.90	12.56	-34.98	-13.00	-21.98	V
5234.76	-34.98	13.10	16.32	-38.20	-13.00	-25.20	V
7109.97	-32.36	12.33	21.13	-41.16	-13.00	-28.16	V



LTE Band 66 / 10MHz / QPSK / RB Size 1 Offset 0/ The Worst Test Results for Lowest							
Frequency(MHz)	S G.Lev (dBm)	Ant(dBi)	Loss	PMea	Limit	Margin	Polarity
				(dBm)	(dBm)	(dBm)	
3429.97	-34.27	12.90	12.56	-33.93	-13.00	-20.93	H
5144.99	-34.74	13.10	16.32	-37.96	-13.00	-24.96	H
6879.90	-33.64	12.33	21.13	-42.44	-13.00	-29.44	H
3429.97	-35.08	12.90	12.56	-34.74	-13.00	-21.74	V
5144.99	-34.32	13.10	16.32	-37.54	-13.00	-24.54	V
6879.90	-32.32	12.33	21.13	-41.12	-13.00	-28.12	V
LTE Band 66 / 10MHz / QPSK / RB Size 1 Offset 0/ The Worst Test Results for Middle							
Frequency(MHz)	S G.Lev (dBm)	Ant(dBi)	Loss	PMea	Limit	Margin	Polarity
				(dBm)	(dBm)	(dBm)	
3490.06	-33.92	12.90	12.56	-33.58	-13.00	-20.58	H
5234.86	-35.10	13.10	16.32	-38.32	-13.00	-25.32	H
6980.12	-33.54	12.33	21.13	-42.34	-13.00	-29.34	H
3490.06	-35.75	12.90	12.56	-35.41	-13.00	-22.41	V
5234.86	-34.09	13.10	16.32	-37.31	-13.00	-24.31	V
6980.12	-33.21	12.33	21.13	-42.01	-13.00	-29.01	V
LTE Band 66 / 10MHz / QPSK / RB Size 1 Offset 0/ The Worst Test Results for Highest							
Frequency(MHz)	S G.Lev (dBm)	Ant(dBi)	Loss	PMea	Limit	Margin	Polarity
				(dBm)	(dBm)	(dBm)	
3550.33	-34.79	12.90	12.56	-34.45	-13.00	-21.45	H
5235.45	-34.50	13.10	16.32	-37.72	-13.00	-24.72	H
7099.88	-33.06	12.33	21.13	-41.86	-13.00	-28.86	H
3550.33	-34.96	12.90	12.56	-34.62	-13.00	-21.62	V
5235.45	-34.21	13.10	16.32	-37.43	-13.00	-24.43	V
7099.88	-32.88	12.33	21.13	-41.68	-13.00	-28.68	V



LTE Band 66 / 15MHz / QPSK / RB Size 1 Offset 0/ The Worst Test Results for Lowest							
Frequency(MHz)	S G.Lev (dBm)	Ant(dBi)	Loss	PMea	Limit	Margin	Polarity
				(dBm)	(dBm)	(dBm)	
3434.87	-34.02	12.90	12.56	-33.68	-13.00	-20.68	H
5152.37	-35.23	13.10	16.32	-38.45	-13.00	-25.45	H
6870.07	-32.77	12.33	21.13	-41.57	-13.00	-28.57	H
3434.87	-35.47	12.90	12.56	-35.13	-13.00	-22.13	V
5152.37	-34.07	13.10	16.32	-37.29	-13.00	-24.29	V
6870.07	-32.95	12.33	21.13	-41.75	-13.00	-28.75	V
LTE Band 66 / 15MHz / QPSK / RB Size 1 Offset 0/ The Worst Test Results for Middle							
Frequency(MHz)	S G.Lev (dBm)	Ant(dBi)	Loss	PMea	Limit	Margin	Polarity
				(dBm)	(dBm)	(dBm)	
3490.23	-34.51	12.90	12.56	-34.17	-13.00	-21.17	H
5235.17	-34.12	13.10	16.32	-37.34	-13.00	-24.34	H
6980.07	-32.21	12.33	21.13	-41.01	-13.00	-28.01	H
3490.23	-34.67	12.90	12.56	-34.33	-13.00	-21.33	V
5235.17	-33.94	13.10	16.32	-37.16	-13.00	-24.16	V
6980.07	-32.99	12.33	21.13	-41.79	-13.00	-28.79	V
LTE Band 66 / 15MHz / QPSK / RB Size 1 Offset 0/ The Worst Test Results for Highest							
Frequency(MHz)	S G.Lev (dBm)	Ant(dBi)	Loss	PMea	Limit	Margin	Polarity
				(dBm)	(dBm)	(dBm)	
3544.84	-34.72	12.90	12.56	-34.38	-13.00	-21.38	H
5332.58	-34.18	13.10	16.32	-37.40	-13.00	-24.40	H
7089.78	-32.16	12.33	21.13	-40.96	-13.00	-27.96	H
3544.84	-34.88	12.90	12.56	-34.54	-13.00	-21.54	V
5332.58	-34.54	13.10	16.32	-37.76	-13.00	-24.76	V
7089.78	-32.50	12.33	21.13	-41.30	-13.00	-28.30	V



LTE Band 66 / 20MHz / QPSK / RB Size 1 Offset 0/ The Worst Test Results for Lowest							
Frequency(MHz)	S G.Lev (dBm)	Ant(dBi)	Loss	PMea	Limit	Margin	Polarity
				(dBm)	(dBm)	(dBm)	
3439.85	-33.66	12.90	12.56	-33.32	-13.00	-20.32	H
5160.15	-34.02	13.10	16.32	-37.24	-13.00	-24.24	H
6879.96	-33.22	12.33	21.13	-42.02	-13.00	-29.02	H
3439.85	-34.61	12.90	12.56	-34.27	-13.00	-21.27	V
5160.15	-34.52	13.10	16.32	-37.74	-13.00	-24.74	V
6879.96	-32.55	12.33	21.13	-41.35	-13.00	-28.35	V
LTE Band 66 / 20MHz / QPSK / RB Size 1 Offset 0/ The Worst Test Results for Middle							
Frequency(MHz)	S G.Lev (dBm)	Ant(dBi)	Loss	PMea	Limit	Margin	Polarity
				(dBm)	(dBm)	(dBm)	
3490.20	-33.59	12.90	12.56	-33.25	-13.00	-20.25	H
5235.14	-35.13	13.10	16.32	-38.35	-13.00	-25.35	H
6979.99	-33.57	12.33	21.13	-42.37	-13.00	-29.37	H
3490.20	-35.64	12.90	12.56	-35.30	-13.00	-22.30	V
5235.14	-34.40	13.10	16.32	-37.62	-13.00	-24.62	V
6979.99	-33.14	12.33	21.13	-41.94	-13.00	-28.94	V
LTE Band 66 / 20MHz / QPSK / RB Size 1 Offset 0/ The Worst Test Results for Highest							
Frequency(MHz)	S G.Lev (dBm)	Ant(dBi)	Loss	PMea	Limit	Margin	Polarity
				(dBm)	(dBm)	(dBm)	
3540.28	-34.10	12.90	12.56	-33.76	-13.00	-20.76	H
5310.23	-34.92	13.10	16.32	-38.14	-13.00	-25.14	H
7080.62	-32.88	12.33	21.13	-41.68	-13.00	-28.68	H
3540.28	-35.59	12.90	12.56	-35.25	-13.00	-22.25	V
5310.23	-33.96	13.10	16.32	-37.18	-13.00	-24.18	V
7080.62	-32.21	12.33	21.13	-41.01	-13.00	-28.01	V



LTE Band 71 / 5MHz / QPSK / RB Size 1 Offset 0/ The Worst Test Results for Lowest							
Frequency(MHz)	S G.Lev (dBm)	Ant(dBi)	Loss	PMea	Limit	Margin	Polarity
				(dBm)	(dBm)	(dBm)	
1331.00	-34.71	8.17	9.34	-35.88	-13.00	-22.88	H
1966.64	-35.17	9.53	10.42	-36.06	-13.00	-23.06	H
2661.94	-32.71	11.27	11.12	-32.56	-13.00	-19.56	H
1331.00	-34.92	8.17	9.34	-36.09	-13.00	-23.09	V
1966.64	-34.33	9.53	10.42	-35.22	-13.00	-22.22	V
2661.94	-32.96	11.27	11.12	-32.81	-13.00	-19.81	V
LTE Band 71 / 5MHz / QPSK / RB Size 1 Offset 0/ The Worst Test Results for Middle							
Frequency(MHz)	S G.Lev (dBm)	Ant(dBi)	Loss	PMea	Limit	Margin	Polarity
				(dBm)	(dBm)	(dBm)	
1361.09	-33.67	8.17	9.34	-34.84	-13.00	-21.84	H
2041.64	-34.89	9.53	10.42	-35.78	-13.00	-22.78	H
2722.08	-33.58	11.27	11.12	-33.43	-13.00	-20.43	H
1361.09	-35.27	8.17	9.34	-36.44	-13.00	-23.44	V
2041.64	-33.91	9.53	10.42	-34.80	-13.00	-21.80	V
2722.08	-33.01	11.27	11.12	-32.86	-13.00	-19.86	V
LTE Band 71 / 5MHz / QPSK / RB Size 1 Offset 0/ The Worst Test Results for Highest							
Frequency(MHz)	S G.Lev (dBm)	Ant(dBi)	Loss	PMea	Limit	Margin	Polarity
				(dBm)	(dBm)	(dBm)	
1391.04	-34.86	8.17	9.34	-36.03	-13.00	-23.03	H
2086.00	-34.78	9.53	10.42	-35.67	-13.00	-22.67	H
2781.71	-33.50	11.27	11.12	-33.35	-13.00	-20.35	H
1391.04	-35.61	8.17	9.34	-36.78	-13.00	-23.78	V
2086.00	-34.09	9.53	10.42	-34.98	-13.00	-21.98	V
2781.71	-32.20	11.27	11.12	-32.05	-13.00	-19.05	V



LTE Band 71 / 10MHz / QPSK / RB Size 1 Offset 0/ The Worst Test Results for Lowest							
Frequency(MHz)	S G.Lev (dBm)	Ant(dBi)	Loss	PMea	Limit	Margin	Polarity
				(dBm)	(dBm)	(dBm)	
1336.07	-34.40	8.17	9.34	-35.57	-13.00	-22.57	H
2004.00	-34.24	9.53	10.42	-35.13	-13.00	-22.13	H
2672.09	-32.84	11.27	11.12	-32.69	-13.00	-19.69	H
1336.07	-35.81	8.17	9.34	-36.98	-13.00	-23.98	V
2004.00	-33.78	9.53	10.42	-34.67	-13.00	-21.67	V
2672.09	-32.24	11.27	11.12	-32.09	-13.00	-19.09	V
LTE Band 71 / 10MHz / QPSK / RB Size 1 Offset 0/ The Worst Test Results for Middle							
Frequency(MHz)	S G.Lev (dBm)	Ant(dBi)	Loss	PMea	Limit	Margin	Polarity
				(dBm)	(dBm)	(dBm)	
1361.22	-34.53	8.17	9.34	-35.70	-13.00	-22.70	H
2041.25	-34.38	9.53	10.42	-35.27	-13.00	-22.27	H
2722.07	-32.44	11.27	11.12	-32.29	-13.00	-19.29	H
1361.22	-35.87	8.17	9.34	-37.04	-13.00	-24.04	V
2041.25	-34.07	9.53	10.42	-34.96	-13.00	-21.96	V
2722.07	-32.35	11.27	11.12	-32.20	-13.00	-19.20	V
LTE Band 71 / 10MHz / QPSK / RB Size 1 Offset 0/ The Worst Test Results for Highest							
Frequency(MHz)	S G.Lev (dBm)	Ant(dBi)	Loss	PMea	Limit	Margin	Polarity
				(dBm)	(dBm)	(dBm)	
1386.19	-34.44	8.17	9.34	-35.61	-13.00	-22.61	H
2078.89	-34.59	9.53	10.42	-35.48	-13.00	-22.48	H
2722.04	-32.77	11.27	11.12	-32.62	-13.00	-19.62	H
1386.19	-35.83	8.17	9.34	-37.00	-13.00	-24.00	V
2078.89	-35.16	9.53	10.42	-36.05	-13.00	-23.05	V
2722.04	-32.76	11.27	11.12	-32.61	-13.00	-19.61	V



LTE Band 71 / 15MHz / QPSK / RB Size 1 Offset 0/ The Worst Test Results for Lowest							
Frequency(MHz)	S G.Lev (dBm)	Ant(dBi)	Loss	PMea	Limit	Margin	Polarity
				(dBm)	(dBm)	(dBm)	
1340.71	-33.86	8.17	9.34	-35.03	-13.00	-22.03	H
2010.81	-34.17	9.53	10.42	-35.06	-13.00	-22.06	H
2681.75	-32.66	11.27	11.12	-32.51	-13.00	-19.51	H
1340.71	-35.13	8.17	9.34	-36.30	-13.00	-23.30	V
2010.81	-34.49	9.53	10.42	-35.38	-13.00	-22.38	V
2681.75	-32.14	11.27	11.12	-31.99	-13.00	-18.99	V
LTE Band 71 / 15MHz / QPSK / RB Size 1 Offset 0/ The Worst Test Results for Middle							
Frequency(MHz)	S G.Lev (dBm)	Ant(dBi)	Loss	PMea	Limit	Margin	Polarity
				(dBm)	(dBm)	(dBm)	
1361.27	-34.00	8.17	9.34	-35.17	-13.00	-22.17	H
2041.49	-35.36	9.53	10.42	-36.25	-13.00	-23.25	H
2721.85	-33.23	11.27	11.12	-33.08	-13.00	-20.08	H
1361.27	-35.75	8.17	9.34	-36.92	-13.00	-23.92	V
2041.49	-34.51	9.53	10.42	-35.40	-13.00	-22.40	V
2721.85	-32.80	11.27	11.12	-32.65	-13.00	-19.65	V
LTE Band 71 / 15MHz / QPSK / RB Size 1 Offset 0/ The Worst Test Results for Highest							
Frequency(MHz)	S G.Lev (dBm)	Ant(dBi)	Loss	PMea	Limit	Margin	Polarity
				(dBm)	(dBm)	(dBm)	
1380.74	-33.56	8.17	9.34	-34.73	-13.00	-21.73	H
2070.77	-34.38	9.53	10.42	-35.27	-13.00	-22.27	H
2761.96	-32.65	11.27	11.12	-32.50	-13.00	-19.50	H
1380.74	-35.70	8.17	9.34	-36.87	-13.00	-23.87	V
2070.77	-33.90	9.53	10.42	-34.79	-13.00	-21.79	V
2761.96	-31.79	11.27	11.12	-31.64	-13.00	-18.64	V



LTE Band 71 / 20MHz / QPSK / RB Size 1 Offset 0/ The Worst Test Results for Lowest							
Frequency(MHz)	S G.Lev (dBm)	Ant(dBi)	Loss	PMea	Limit	Margin	Polarity
				(dBm)	(dBm)	(dBm)	
1345.93	-33.93	8.17	9.34	-35.10	-13.00	-22.10	H
2019.03	-34.45	9.53	10.42	-35.34	-13.00	-22.34	H
2692.19	-32.38	11.27	11.12	-32.23	-13.00	-19.23	H
1345.93	-34.86	8.17	9.34	-36.03	-13.00	-23.03	V
2019.03	-34.40	9.53	10.42	-35.29	-13.00	-22.29	V
2692.19	-32.32	11.27	11.12	-32.17	-13.00	-19.17	V
LTE Band 71 / 20MHz / QPSK / RB Size 1 Offset 0/ The Worst Test Results for Middle							
Frequency(MHz)	S G.Lev (dBm)	Ant(dBi)	Loss	PMea	Limit	Margin	Polarity
				(dBm)	(dBm)	(dBm)	
1361.03	-33.65	8.17	9.34	-34.82	-13.00	-21.82	H
2041.36	-34.46	9.53	10.42	-35.35	-13.00	-22.35	H
2721.99	-32.42	11.27	11.12	-32.27	-13.00	-19.27	H
1361.03	-35.86	8.17	9.34	-37.03	-13.00	-24.03	V
2041.36	-34.39	9.53	10.42	-35.28	-13.00	-22.28	V
2721.99	-33.10	11.27	11.12	-32.95	-13.00	-19.95	V
LTE Band 71 / 20MHz / QPSK / RB Size 1 Offset 0/ The Worst Test Results for Highest							
Frequency(MHz)	S G.Lev (dBm)	Ant(dBi)	Loss	PMea	Limit	Margin	Polarity
				(dBm)	(dBm)	(dBm)	
1375.72	-34.67	8.17	9.34	-35.84	-13.00	-22.84	H
2064.07	-34.44	9.53	10.42	-35.33	-13.00	-22.33	H
2751.79	-32.98	11.27	11.12	-32.83	-13.00	-19.83	H
1375.72	-35.92	8.17	9.34	-37.09	-13.00	-24.09	V
2064.07	-34.50	9.53	10.42	-35.39	-13.00	-22.39	V
2751.79	-32.24	11.27	11.12	-32.09	-13.00	-19.09	V



Model: MOX 2

GSM 850: (30-9000)MHz							
The Worst Test Results Channel 128/824.2 MHz							
Frequency(MHz)	S G.Lev (dBm)	Ant(dBi)	Loss	PMea (dBm)	Limit (dBm)	Margin (dBm)	Polarity
1648.29	-41.62	9.40	4.75	-36.97	-13.00	-23.97	H
2472.54	-39.61	10.60	8.39	-37.40	-13.00	-24.40	H
3296.72	-32.33	12.00	11.79	-32.12	-13.00	-19.12	H
1648.29	-43.59	9.40	4.75	-38.94	-13.00	-25.94	V
2472.54	-45.22	10.60	8.39	-43.01	-13.00	-30.01	V
3296.72	-43.48	12.00	11.79	-43.27	-13.00	-30.27	V
The Worst Test Results Channel 190/836.6 MHz							
Frequency(MHz)	S G.Lev (dBm)	Ant(dBi)	Loss	PMea (dBm)	Limit (dBm)	Margin (dBm)	Polarity
1672.94	-40.55	9.50	4.76	-35.81	-13.00	-22.81	H
2509.49	-40.50	10.70	8.40	-38.20	-13.00	-25.20	H
3346.09	-32.16	12.20	11.80	-31.76	-13.00	-18.76	H
1672.94	-43.53	9.40	4.75	-38.88	-13.00	-25.88	V
2509.49	-45.09	10.60	8.39	-42.88	-13.00	-29.88	V
3346.09	-42.73	12.20	11.82	-42.35	-13.00	-29.35	V
The Worst Test Results Channel 251/848.8 MHz							
Frequency(MHz)	S G.Lev (dBm)	Ant(dBi)	Loss	PMea (dBm)	Limit (dBm)	Margin (dBm)	Polarity
1697.36	-40.18	9.60	4.77	-35.35	-13.00	-22.35	H
2546.48	-40.03	10.80	8.50	-37.73	-13.00	-24.73	H
3395.21	-31.74	12.50	11.90	-31.14	-13.00	-18.14	H
1697.36	-44.30	9.60	4.77	-39.47	-13.00	-26.47	V
2546.48	-45.40	10.80	8.50	-43.10	-13.00	-30.10	V
3395.21	-43.93	12.50	11.90	-43.33	-13.00	-30.33	V



GPRS 850: (30-9000)MHz							
The Worst Test Results Channel 128/824.2 MHz							
Frequency(MHz)	S G.Lev (dBm)	Ant(dBi)	Loss	PMea (dBm)	Limit (dBm)	Margin (dBm)	Polarity
1648.40	-41.46	9.40	4.75	-36.81	-13.00	-23.81	H
2472.57	-40.35	10.60	8.39	-38.14	-13.00	-25.14	H
3296.70	-32.29	12.00	11.79	-32.08	-13.00	-19.08	H
1648.40	-43.43	9.40	4.75	-38.78	-13.00	-25.78	V
2472.57	-45.41	10.60	8.39	-43.20	-13.00	-30.20	V
3296.70	-42.93	12.00	11.79	-42.72	-13.00	-29.72	V
The Worst Test Results Channel 190/836.6 MHz							
Frequency(MHz)	S G.Lev (dBm)	Ant(dBi)	Loss	PMea (dBm)	Limit (dBm)	Margin (dBm)	Polarity
1672.85	-41.05	9.50	4.76	-36.31	-13.00	-23.31	H
2509.62	-40.21	10.70	8.40	-37.91	-13.00	-24.91	H
3346.14	-31.33	12.20	11.80	-30.93	-13.00	-17.93	H
1672.85	-43.39	9.40	4.75	-38.74	-13.00	-25.74	V
2509.62	-45.17	10.60	8.39	-42.96	-13.00	-29.96	V
3346.14	-43.23	12.20	11.82	-42.85	-13.00	-29.85	V
The Worst Test Results Channel 251/848.8 MHz							
Frequency(MHz)	S G.Lev (dBm)	Ant(dBi)	Loss	PMea (dBm)	Limit (dBm)	Margin (dBm)	Polarity
1697.19	-40.66	9.60	4.77	-35.83	-13.00	-22.83	H
2546.41	-40.53	10.80	8.50	-38.23	-13.00	-25.23	H
3395.15	-31.07	12.50	11.90	-30.47	-13.00	-17.47	H
1697.19	-44.37	9.60	4.77	-39.54	-13.00	-26.54	V
2546.41	-45.27	10.80	8.50	-42.97	-13.00	-29.97	V
3395.15	-43.67	12.50	11.90	-43.07	-13.00	-30.07	V



PCS 1900: (30-20000)MHz							
The Worst Test Results for Channel 512/1850.2MHz							
Frequency(MHz)	S G.Lev (dBm)	Ant(dBi)	Loss	PMea (dBm)	Limit (dBm)	Margin (dBm)	Polarity
3700.24	-34.40	12.60	12.93	-34.73	-13.00	-21.73	H
5550.49	-34.36	13.10	17.11	-38.37	-13.00	-25.37	H
7400.52	-33.23	11.50	22.20	-43.93	-13.00	-30.93	H
3700.24	-34.96	12.60	12.93	-35.29	-13.00	-22.29	V
5550.49	-34.12	13.10	17.11	-38.13	-13.00	-25.13	V
7400.52	-32.83	11.50	22.20	-43.53	-13.00	-30.53	V
The Worst Test Results for Channel 661/1880.0MHz							
Frequency(MHz)	S G.Lev (dBm)	Ant(dBi)	Loss	PMea (dBm)	Limit (dBm)	Margin (dBm)	Polarity
3759.92	-33.69	12.60	12.93	-34.02	-13.00	-21.02	H
5640.19	-34.51	13.10	17.11	-38.52	-13.00	-25.52	H
7519.85	-33.32	11.50	22.20	-44.02	-13.00	-31.02	H
3759.92	-34.60	12.60	12.93	-34.93	-13.00	-21.93	V
5640.19	-34.83	13.10	17.11	-38.84	-13.00	-25.84	V
7519.85	-31.73	11.50	22.20	-42.43	-13.00	-29.43	V
The Worst Test Results for Channel 810/1909.8MHz							
Frequency(MHz)	S G.Lev (dBm)	Ant(dBi)	Loss	PMea (dBm)	Limit (dBm)	Margin (dBm)	Polarity
3819.65	-33.53	12.60	12.93	-33.86	-13.00	-20.86	H
5729.13	-34.88	13.10	17.11	-38.89	-13.00	-25.89	H
7639.12	-32.96	11.50	22.20	-43.66	-13.00	-30.66	H
3819.65	-35.02	12.60	12.93	-35.35	-13.00	-22.35	V
5729.13	-34.50	13.10	17.11	-38.51	-13.00	-25.51	V
7639.12	-32.64	11.50	22.20	-43.34	-13.00	-30.34	V



GPRS1900: (30-20000)MHz							
The Worst Test Results for Channel 512/1850.2MHz							
Frequency(MHz)	S G.Lev (dBm)	Ant(dBi)	Loss	PMea (dBm)	Limit (dBm)	Margin (dBm)	Polarity
3700.01	-33.53	12.60	12.93	-33.86	-13.00	-20.86	H
5550.21	-35.42	13.10	17.11	-39.43	-13.00	-26.43	H
7400.57	-33.06	11.50	22.20	-43.76	-13.00	-30.76	H
3700.01	-34.73	12.60	12.93	-35.06	-13.00	-22.06	V
5550.21	-33.91	13.10	17.11	-37.92	-13.00	-24.92	V
7400.57	-32.74	11.50	22.20	-43.44	-13.00	-30.44	V
The Worst Test Results for Channel 661/1880.0MHz							
Frequency(MHz)	S G.Lev (dBm)	Ant(dBi)	Loss	PMea (dBm)	Limit (dBm)	Margin (dBm)	Polarity
3759.87	-33.79	12.60	12.93	-34.12	-13.00	-21.12	H
5640.24	-34.93	13.10	17.11	-38.94	-13.00	-25.94	H
7520.16	-32.58	11.50	22.20	-43.28	-13.00	-30.28	H
3759.87	-35.52	12.60	12.93	-35.85	-13.00	-22.85	V
5640.24	-34.68	13.10	17.11	-38.69	-13.00	-25.69	V
7520.16	-33.01	11.50	22.20	-43.71	-13.00	-30.71	V
The Worst Test Results for Channel 810/1909.8MHz							
Frequency(MHz)	S G.Lev (dBm)	Ant(dBi)	Loss	PMea (dBm)	Limit (dBm)	Margin (dBm)	Polarity
3819.36	-34.50	12.60	12.93	-34.83	-13.00	-21.83	H
5729.48	-34.53	13.10	17.11	-38.54	-13.00	-25.54	H
7639.17	-33.29	11.50	22.20	-43.99	-13.00	-30.99	H
3819.36	-35.17	12.60	12.93	-35.50	-13.00	-22.50	V
5729.48	-34.60	13.10	17.11	-38.61	-13.00	-25.61	V
7639.17	-32.96	11.50	22.20	-43.66	-13.00	-30.66	V



EGPRS 850: (30-9000)MHz							
The Worst Test Results Channel 128/824.2 MHz							
Frequency(MHz)	S G.Lev (dBm)	Ant(dBi)	Loss	PMea (dBm)	Limit (dBm)	Margin (dBm)	Polarity
1648.45	-41.56	9.40	4.75	-36.91	-13.00	-23.91	H
2472.38	-40.43	10.60	8.39	-38.22	-13.00	-25.22	H
3296.72	-32.34	12.00	11.79	-32.13	-13.00	-19.13	H
1648.45	-43.54	9.40	4.75	-38.89	-13.00	-25.89	V
2472.38	-45.32	10.60	8.39	-43.11	-13.00	-30.11	V
3296.72	-43.82	12.00	11.79	-43.61	-13.00	-30.61	V
The Worst Test Results Channel 190/836.6 MHz							
Frequency(MHz)	S G.Lev (dBm)	Ant(dBi)	Loss	PMea (dBm)	Limit (dBm)	Margin (dBm)	Polarity
1672.88	-40.87	9.50	4.76	-36.13	-13.00	-23.13	H
2509.62	-39.95	10.70	8.40	-37.65	-13.00	-24.65	H
3346.27	-30.95	12.20	11.80	-30.55	-13.00	-17.55	H
1672.88	-43.36	9.40	4.75	-38.71	-13.00	-25.71	V
2509.62	-44.07	10.60	8.39	-41.86	-13.00	-28.86	V
3346.27	-42.93	12.20	11.82	-42.55	-13.00	-29.55	V
The Worst Test Results Channel 251/848.8 MHz							
Frequency(MHz)	S G.Lev (dBm)	Ant(dBi)	Loss	PMea (dBm)	Limit (dBm)	Margin (dBm)	Polarity
1697.40	-41.17	9.60	4.77	-36.34	-13.00	-23.34	H
2546.32	-39.95	10.80	8.50	-37.65	-13.00	-24.65	H
3395.32	-31.02	12.50	11.90	-30.42	-13.00	-17.42	H
1697.40	-44.50	9.60	4.77	-39.67	-13.00	-26.67	V
2546.32	-45.45	10.80	8.50	-43.15	-13.00	-30.15	V
3395.32	-43.84	12.50	11.90	-43.24	-13.00	-30.24	V



EGPRS 1900: (30-20000)MHz							
The Worst Test Results for Channel 512/1850.2MHz							
Frequency(MHz)	S G.Lev (dBm)	Ant(dBi)	Loss	PMea (dBm)	Limit (dBm)	Margin (dBm)	Polarity
3700.25	-33.96	12.60	12.93	-34.29	-13.00	-21.29	H
5550.41	-34.90	13.10	17.11	-38.91	-13.00	-25.91	H
7400.52	-32.89	11.50	22.20	-43.59	-13.00	-30.59	H
3700.25	-35.11	12.60	12.93	-35.44	-13.00	-22.44	V
5550.41	-34.86	13.10	17.11	-38.87	-13.00	-25.87	V
7400.52	-31.85	11.50	22.20	-42.55	-13.00	-29.55	V
The Worst Test Results for Channel 661/1880.0MHz							
Frequency(MHz)	S G.Lev (dBm)	Ant(dBi)	Loss	PMea (dBm)	Limit (dBm)	Margin (dBm)	Polarity
3760.06	-33.63	12.60	12.93	-33.96	-13.00	-20.96	H
5639.93	-34.79	13.10	17.11	-38.80	-13.00	-25.80	H
7519.81	-32.38	11.50	22.20	-43.08	-13.00	-30.08	H
3760.06	-35.97	12.60	12.93	-36.30	-13.00	-23.30	V
5639.93	-35.18	13.10	17.11	-39.19	-13.00	-26.19	V
7519.81	-31.96	11.50	22.20	-42.66	-13.00	-29.66	V
The Worst Test Results for Channel 810/1909.8MHz							
Frequency(MHz)	S G.Lev (dBm)	Ant(dBi)	Loss	PMea (dBm)	Limit (dBm)	Margin (dBm)	Polarity
3819.52	-34.71	12.60	12.93	-35.04	-13.00	-22.04	H
5729.27	-34.50	13.10	17.11	-38.51	-13.00	-25.51	H
7639.09	-33.00	11.50	22.20	-43.70	-13.00	-30.70	H
3819.52	-34.76	12.60	12.93	-35.09	-13.00	-22.09	V
5729.27	-34.62	13.10	17.11	-38.63	-13.00	-25.63	V
7639.09	-33.06	11.50	22.20	-43.76	-13.00	-30.76	V



LTE Band 2 / 1.4MHz / QPSK / RB Size 1 Offset 0/ The Worst Test Results for Lowest							
Frequency(MHz)	S G.Lev (dBm)	Ant(dBi)	Loss	PMea	Limit	Margin	Polarity
				(dBm)	(dBm)	(dBm)	
3701.30	-34.27	12.60	12.93	-34.60	-13.00	-21.60	H
5551.70	-34.64	13.10	17.11	-38.65	-13.00	-25.65	H
7402.84	-32.64	11.50	22.20	-43.34	-13.00	-30.34	H
3701.30	-35.46	12.60	12.93	-35.79	-13.00	-22.79	V
5551.70	-34.29	13.10	17.11	-38.30	-13.00	-25.30	V
7402.84	-32.16	11.50	22.20	-42.86	-13.00	-29.86	V
LTE Band 2 / 1.4MHz / QPSK / RB Size 1 Offset 0/ The Worst Test Results for Middle							
Frequency(MHz)	S G.Lev (dBm)	Ant(dBi)	Loss	PMea	Limit	Margin	Polarity
				(dBm)	(dBm)	(dBm)	
3760.02	-34.92	12.60	12.93	-35.25	-13.00	-22.25	H
5639.87	-34.64	13.10	17.11	-38.65	-13.00	-25.65	H
7520.05	-33.60	11.50	22.20	-44.30	-13.00	-31.30	H
3760.02	-34.95	12.60	12.93	-35.28	-13.00	-22.28	V
5639.87	-34.19	13.10	17.11	-38.20	-13.00	-25.20	V
7520.05	-32.30	11.50	22.20	-43.00	-13.00	-30.00	V
LTE Band 2 / 1.4MHz / QPSK / RB Size 1 Offset 0/ The Worst Test Results for Highest							
Frequency(MHz)	S G.Lev (dBm)	Ant(dBi)	Loss	PMea	Limit	Margin	Polarity
				(dBm)	(dBm)	(dBm)	
3818.28	-33.75	12.60	12.93	-34.08	-13.00	-21.08	H
5727.42	-34.08	13.10	17.11	-38.09	-13.00	-25.09	H
7636.94	-32.58	11.50	22.20	-43.28	-13.00	-30.28	H
3818.28	-35.02	12.60	12.93	-35.35	-13.00	-22.35	V
5727.42	-34.68	13.10	17.11	-38.69	-13.00	-25.69	V
7636.94	-32.72	11.50	22.20	-43.42	-13.00	-30.42	V



LTE Band 2 / 3MHz / QPSK / RB Size 1 Offset 0/ The Worst Test Results for Lowest							
Frequency(MHz)	S G.Lev (dBm)	Ant(dBi)	Loss	PMea	Limit	Margin	Polarity
				(dBm)	(dBm)	(dBm)	
3703.16	-34.23	12.60	12.93	-34.56	-13.00	-21.56	H
5554.24	-34.93	13.10	17.11	-38.94	-13.00	-25.94	H
7405.97	-32.36	11.50	22.20	-43.06	-13.00	-30.06	H
3703.16	-34.91	12.60	12.93	-35.24	-13.00	-22.24	V
5554.24	-33.95	13.10	17.11	-37.96	-13.00	-24.96	V
7405.97	-31.85	11.50	22.20	-42.55	-13.00	-29.55	V
LTE Band 2 / 3MHz / QPSK / RB Size 1 Offset 0/ The Worst Test Results for Middle							
Frequency(MHz)	S G.Lev (dBm)	Ant(dBi)	Loss	PMea	Limit	Margin	Polarity
				(dBm)	(dBm)	(dBm)	
3760.04	-34.20	12.60	12.93	-34.53	-13.00	-21.53	H
5640.15	-35.16	13.10	17.11	-39.17	-13.00	-26.17	H
7519.96	-32.83	11.50	22.20	-43.53	-13.00	-30.53	H
3760.04	-35.40	12.60	12.93	-35.73	-13.00	-22.73	V
5640.15	-34.21	13.10	17.11	-38.22	-13.00	-25.22	V
7519.96	-32.90	11.50	22.20	-43.60	-13.00	-30.60	V
LTE Band 2 / 3MHz / QPSK / RB Size 1 Offset 0/ The Worst Test Results for Highest							
Frequency(MHz)	S G.Lev (dBm)	Ant(dBi)	Loss	PMea	Limit	Margin	Polarity
				(dBm)	(dBm)	(dBm)	
3816.97	-33.52	12.60	12.93	-33.85	-13.00	-20.85	H
5725.64	-35.34	13.10	17.11	-39.35	-13.00	-26.35	H
7633.83	-32.77	11.50	22.20	-43.47	-13.00	-30.47	H
3816.97	-34.95	12.60	12.93	-35.28	-13.00	-22.28	V
5725.64	-34.32	13.10	17.11	-38.33	-13.00	-25.33	V
7633.83	-33.03	11.50	22.20	-43.73	-13.00	-30.73	V



LTE Band 2 / 5MHz / QPSK / RB Size 1 Offset 0/ The Worst Test Results for Lowest							
Frequency(MHz)	S G.Lev (dBm)	Ant(dBi)	Loss	PMea	Limit	Margin	Polarity
				(dBm)	(dBm)	(dBm)	
3705.34	-33.65	12.60	12.93	-33.98	-13.00	-20.98	H
5557.44	-35.30	13.10	17.11	-39.31	-13.00	-26.31	H
7409.89	-33.30	11.50	22.20	-44.00	-13.00	-31.00	H
3705.34	-35.78	12.60	12.93	-36.11	-13.00	-23.11	V
5557.44	-34.96	13.10	17.11	-38.97	-13.00	-25.97	V
7409.89	-32.21	11.50	22.20	-42.91	-13.00	-29.91	V
LTE Band 2 / 5MHz / QPSK / RB Size 1 Offset 0/ The Worst Test Results for Middle							
Frequency(MHz)	S G.Lev (dBm)	Ant(dBi)	Loss	PMea	Limit	Margin	Polarity
				(dBm)	(dBm)	(dBm)	
3759.92	-34.62	12.60	12.93	-34.95	-13.00	-21.95	H
5639.91	-34.12	13.10	17.11	-38.13	-13.00	-25.13	H
7519.95	-32.16	11.50	22.20	-42.86	-13.00	-29.86	H
3759.92	-35.51	12.60	12.93	-35.84	-13.00	-22.84	V
5639.91	-34.84	13.10	17.11	-38.85	-13.00	-25.85	V
7519.95	-31.88	11.50	22.20	-42.58	-13.00	-29.58	V
LTE Band 2 / 5MHz / QPSK / RB Size 1 Offset 0/ The Worst Test Results for Highest							
Frequency(MHz)	S G.Lev (dBm)	Ant(dBi)	Loss	PMea	Limit	Margin	Polarity
				(dBm)	(dBm)	(dBm)	
3815.25	-34.86	12.60	12.93	-35.19	-13.00	-22.19	H
5722.54	-35.30	13.10	17.11	-39.31	-13.00	-26.31	H
7630.02	-33.33	11.50	22.20	-44.03	-13.00	-31.03	H
3815.25	-34.99	12.60	12.93	-35.32	-13.00	-22.32	V
5722.54	-35.18	13.10	17.11	-39.19	-13.00	-26.19	V
7630.02	-32.20	11.50	22.20	-42.90	-13.00	-29.90	V



LTE Band 2 / 10MHz / QPSK / RB Size 1 Offset 0/ The Worst Test Results for Lowest							
Frequency(MHz)	S G.Lev (dBm)	Ant(dBi)	Loss	PMea	Limit	Margin	Polarity
				(dBm)	(dBm)	(dBm)	
3710.00	-34.64	12.60	12.93	-34.97	-13.00	-21.97	H
5565.26	-34.36	13.10	17.11	-38.37	-13.00	-25.37	H
7420.15	-33.25	11.50	22.20	-43.95	-13.00	-30.95	H
3710.00	-35.09	12.60	12.93	-35.42	-13.00	-22.42	V
5565.26	-34.90	13.10	17.11	-38.91	-13.00	-25.91	V
7420.15	-31.84	11.50	22.20	-42.54	-13.00	-29.54	V
LTE Band 2 / 10MHz / QPSK / RB Size 1 Offset 0/ The Worst Test Results for Middle							
Frequency(MHz)	S G.Lev (dBm)	Ant(dBi)	Loss	PMea	Limit	Margin	Polarity
				(dBm)	(dBm)	(dBm)	
3760.23	-34.52	12.60	12.93	-34.85	-13.00	-21.85	H
5640.00	-35.30	13.10	17.11	-39.31	-13.00	-26.31	H
7520.01	-33.02	11.50	22.20	-43.72	-13.00	-30.72	H
3760.23	-35.14	12.60	12.93	-35.47	-13.00	-22.47	V
5640.00	-33.77	13.10	17.11	-37.78	-13.00	-24.78	V
7520.01	-32.80	11.50	22.20	-43.50	-13.00	-30.50	V
LTE Band 2 / 10MHz / QPSK / RB Size 1 Offset 0/ The Worst Test Results for Highest							
Frequency(MHz)	S G.Lev (dBm)	Ant(dBi)	Loss	PMea	Limit	Margin	Polarity
				(dBm)	(dBm)	(dBm)	
3810.06	-33.48	12.60	12.93	-33.81	-13.00	-20.81	H
5714.63	-35.45	13.10	17.11	-39.46	-13.00	-26.46	H
7619.92	-32.15	11.50	22.20	-42.85	-13.00	-29.85	H
3810.06	-35.71	12.60	12.93	-36.04	-13.00	-23.04	V
5714.63	-33.80	13.10	17.11	-37.81	-13.00	-24.81	V
7619.92	-32.85	11.50	22.20	-43.55	-13.00	-30.55	V



LTE Band 2 / 15MHz / QPSK / RB Size 1 Offset 0/ The Worst Test Results for Lowest							
Frequency(MHz)	S G.Lev (dBm)	Ant(dBi)	Loss	PMea	Limit	Margin	Polarity
				(dBm)	(dBm)	(dBm)	
3714.97	-34.31	12.60	12.93	-34.64	-13.00	-21.64	H
5572.19	-35.27	13.10	17.11	-39.28	-13.00	-26.28	H
7430.46	-32.24	11.50	22.20	-42.94	-13.00	-29.94	H
3714.97	-34.88	12.60	12.93	-35.21	-13.00	-22.21	V
5572.19	-34.43	13.10	17.11	-38.44	-13.00	-25.44	V
7430.46	-32.98	11.50	22.20	-43.68	-13.00	-30.68	V
LTE Band 2 / 15MHz / QPSK / RB Size 1 Offset 0/ The Worst Test Results for Middle							
Frequency(MHz)	S G.Lev (dBm)	Ant(dBi)	Loss	PMea	Limit	Margin	Polarity
				(dBm)	(dBm)	(dBm)	
3759.86	-33.94	12.60	12.93	-34.27	-13.00	-21.27	H
5640.21	-34.04	13.10	17.11	-38.05	-13.00	-25.05	H
7520.17	-32.34	11.50	22.20	-43.04	-13.00	-30.04	H
3759.86	-34.66	12.60	12.93	-34.99	-13.00	-21.99	V
5640.21	-33.86	13.10	17.11	-37.87	-13.00	-24.87	V
7520.17	-31.98	11.50	22.20	-42.68	-13.00	-29.68	V
LTE Band 2 / 15MHz / QPSK / RB Size 1 Offset 0/ The Worst Test Results for Highest							
Frequency(MHz)	S G.Lev (dBm)	Ant(dBi)	Loss	PMea	Limit	Margin	Polarity
				(dBm)	(dBm)	(dBm)	
3805.29	-34.51	12.60	12.93	-34.84	-13.00	-21.84	H
5707.53	-35.45	13.10	17.11	-39.46	-13.00	-26.46	H
7609.86	-33.11	11.50	22.20	-43.81	-13.00	-30.81	H
3805.29	-35.50	12.60	12.93	-35.83	-13.00	-22.83	V
5707.53	-33.96	13.10	17.11	-37.97	-13.00	-24.97	V
7609.86	-32.91	11.50	22.20	-43.61	-13.00	-30.61	V



LTE Band 2 / 20MHz / QPSK / RB Size 1 Offset 0/ The Worst Test Results for Lowest							
Frequency(MHz)	S G.Lev (dBm)	Ant(dBi)	Loss	PMea	Limit	Margin	Polarity
				(dBm)	(dBm)	(dBm)	
3720.08	-34.27	12.60	12.93	-34.60	-13.00	-21.60	H
5580.41	-35.01	13.10	17.11	-39.02	-13.00	-26.02	H
7439.76	-32.60	11.50	22.20	-43.30	-13.00	-30.30	H
3720.08	-35.91	12.60	12.93	-36.24	-13.00	-23.24	V
5580.41	-34.25	13.10	17.11	-38.26	-13.00	-25.26	V
7439.76	-33.11	11.50	22.20	-43.81	-13.00	-30.81	V
LTE Band 2 / 20MHz / QPSK / RB Size 1 Offset 0/ The Worst Test Results for Middle							
Frequency(MHz)	S G.Lev (dBm)	Ant(dBi)	Loss	PMea	Limit	Margin	Polarity
				(dBm)	(dBm)	(dBm)	
3759.89	-33.80	12.60	12.93	-34.13	-13.00	-21.13	H
5639.90	-35.14	13.10	17.11	-39.15	-13.00	-26.15	H
7520.03	-32.67	11.50	22.20	-43.37	-13.00	-30.37	H
3759.89	-35.84	12.60	12.93	-36.17	-13.00	-23.17	V
5639.90	-34.72	13.10	17.11	-38.73	-13.00	-25.73	V
7520.03	-32.99	11.50	22.20	-43.69	-13.00	-30.69	V
LTE Band 2 / 20MHz / QPSK / RB Size 1 Offset 0/ The Worst Test Results for Highest							
Frequency(MHz)	S G.Lev (dBm)	Ant(dBi)	Loss	PMea	Limit	Margin	Polarity
				(dBm)	(dBm)	(dBm)	
3799.74	-33.72	12.60	12.93	-34.05	-13.00	-21.05	H
5699.77	-35.09	13.10	17.11	-39.10	-13.00	-26.10	H
7599.81	-32.33	11.50	22.20	-43.03	-13.00	-30.03	H
3799.74	-35.85	12.60	12.93	-36.18	-13.00	-23.18	V
5699.77	-34.30	13.10	17.11	-38.31	-13.00	-25.31	V
7599.81	-32.49	11.50	22.20	-43.19	-13.00	-30.19	V



LTE Band 4 / 1.4MHz / QPSK / RB Size 1 Offset 0/ The Worst Test Results for Lowest							
Frequency(MHz)	S G.Lev (dBm)	Ant(dBi)	Loss	PMea	Limit	Margin	Polarity
				(dBm)	(dBm)	(dBm)	
3420.99	-34.58	12.90	12.56	-34.24	-13.00	-21.24	H
5132.14	-34.81	13.10	16.32	-38.03	-13.00	-25.03	H
6842.62	-33.50	12.33	21.13	-42.30	-13.00	-29.30	H
3420.99	-35.70	12.90	12.56	-35.36	-13.00	-22.36	V
5132.14	-34.57	13.10	16.32	-37.79	-13.00	-24.79	V
6842.62	-31.89	12.33	21.13	-40.69	-13.00	-27.69	V
LTE Band 4 / 1.4MHz / QPSK / RB Size 1 Offset 0/ The Worst Test Results for Middle							
Frequency(MHz)	S G.Lev (dBm)	Ant(dBi)	Loss	PMea	Limit	Margin	Polarity
				(dBm)	(dBm)	(dBm)	
3464.66	-34.02	12.90	12.56	-33.68	-13.00	-20.68	H
5196.81	-34.92	13.10	16.32	-38.14	-13.00	-25.14	H
6929.87	-33.18	12.33	21.13	-41.98	-13.00	-28.98	H
3464.66	-35.53	12.90	12.56	-35.19	-13.00	-22.19	V
5196.81	-34.28	13.10	16.32	-37.50	-13.00	-24.50	V
6929.87	-31.94	12.33	21.13	-40.74	-13.00	-27.74	V
LTE Band 4 / 1.4MHz / QPSK / RB Size 1 Offset 0/ The Worst Test Results for Highest							
Frequency(MHz)	S G.Lev (dBm)	Ant(dBi)	Loss	PMea	Limit	Margin	Polarity
				(dBm)	(dBm)	(dBm)	
3508.41	-34.37	12.90	12.56	-34.03	-13.00	-21.03	H
5262.30	-34.17	13.10	16.32	-37.39	-13.00	-24.39	H
7015.77	-32.79	12.33	21.13	-41.59	-13.00	-28.59	H
3508.41	-35.06	12.90	12.56	-34.72	-13.00	-21.72	V
5262.30	-34.14	13.10	16.32	-37.36	-13.00	-24.36	V
7015.77	-31.99	12.33	21.13	-40.79	-13.00	-27.79	V



LTE Band 4 / 3MHz / QPSK / RB Size 1 Offset 0/ The Worst Test Results for Lowest							
Frequency(MHz)	S G.Lev (dBm)	Ant(dBi)	Loss	PMea	Limit	Margin	Polarity
	(dBm)			(dBm)	(dBm)		
3424.01	-33.91	12.90	12.56	-33.57	-13.00	-20.57	H
5136.17	-34.46	13.10	16.32	-37.68	-13.00	-24.68	H
6848.82	-32.90	12.33	21.13	-41.70	-13.00	-28.70	H
3424.01	-35.72	12.90	12.56	-35.38	-13.00	-22.38	V
5136.17	-34.97	13.10	16.32	-38.19	-13.00	-25.19	V
6848.82	-33.00	12.33	21.13	-41.80	-13.00	-28.80	V
LTE Band 4 / 3MHz / QPSK / RB Size 1 Offset 0/ The Worst Test Results for Middle							
Frequency(MHz)	S G.Lev (dBm)	Ant(dBi)	Loss	PMea	Limit	Margin	Polarity
	(dBm)			(dBm)	(dBm)		
3464.66	-34.70	12.90	12.56	-34.36	-13.00	-21.36	H
5196.66	-35.12	13.10	16.32	-38.34	-13.00	-25.34	H
6930.01	-32.81	12.33	21.13	-41.61	-13.00	-28.61	H
3464.66	-35.51	12.90	12.56	-35.17	-13.00	-22.17	V
5196.66	-34.74	13.10	16.32	-37.96	-13.00	-24.96	V
6930.01	-33.06	12.33	21.13	-41.86	-13.00	-28.86	V
LTE Band 4 / 3MHz / QPSK / RB Size 1 Offset 0/ The Worst Test Results for Highest							
Frequency(MHz)	S G.Lev (dBm)	Ant(dBi)	Loss	PMea	Limit	Margin	Polarity
	(dBm)			(dBm)	(dBm)		
3506.09	-33.88	12.90	12.56	-33.54	-13.00	-20.54	H
5261.84	-35.27	13.10	16.32	-38.49	-13.00	-25.49	H
7012.81	-32.96	12.33	21.13	-41.76	-13.00	-28.76	H
3506.09	-34.88	12.90	12.56	-34.54	-13.00	-21.54	V
5261.84	-35.12	13.10	16.32	-38.34	-13.00	-25.34	V
7012.81	-32.39	12.33	21.13	-41.19	-13.00	-28.19	V



LTE Band 4 / 5MHz / QPSK / RB Size 1 Offset 0/ The Worst Test Results for Lowest							
Frequency(MHz)	S G.Lev (dBm)	Ant(dBi)	Loss	PMea	Limit	Margin	Polarity
				(dBm)	(dBm)	(dBm)	
3424.71	-34.23	12.90	12.56	-33.89	-13.00	-20.89	H
5136.90	-35.30	13.10	16.32	-38.52	-13.00	-25.52	H
6849.78	-33.23	12.33	21.13	-42.03	-13.00	-29.03	H
3424.71	-35.52	12.90	12.56	-35.18	-13.00	-22.18	V
5136.90	-33.95	13.10	16.32	-37.17	-13.00	-24.17	V
6849.78	-32.32	12.33	21.13	-41.12	-13.00	-28.12	V
LTE Band 4 / 5MHz / QPSK / RB Size 1 Offset 0/ The Worst Test Results for Middle							
Frequency(MHz)	S G.Lev (dBm)	Ant(dBi)	Loss	PMea	Limit	Margin	Polarity
				(dBm)	(dBm)	(dBm)	
3464.40	-34.43	12.90	12.56	-34.09	-13.00	-21.09	H
5196.89	-34.68	13.10	16.32	-37.90	-13.00	-24.90	H
6929.60	-33.54	12.33	21.13	-42.34	-13.00	-29.34	H
3464.40	-35.98	12.90	12.56	-35.64	-13.00	-22.64	V
5196.89	-34.27	13.10	16.32	-37.49	-13.00	-24.49	V
6929.60	-31.91	12.33	21.13	-40.71	-13.00	-27.71	V
LTE Band 4 / 5MHz / QPSK / RB Size 1 Offset 0/ The Worst Test Results for Highest							
Frequency(MHz)	S G.Lev (dBm)	Ant(dBi)	Loss	PMea	Limit	Margin	Polarity
				(dBm)	(dBm)	(dBm)	
3505.08	-34.23	12.90	12.56	-33.89	-13.00	-20.89	H
5256.90	-34.67	13.10	16.32	-37.89	-13.00	-24.89	H
7010.05	-33.09	12.33	21.13	-41.89	-13.00	-28.89	H
3505.08	-34.55	12.90	12.56	-34.21	-13.00	-21.21	V
5256.90	-34.70	13.10	16.32	-37.92	-13.00	-24.92	V
7010.05	-31.80	12.33	21.13	-40.60	-13.00	-27.60	V



LTE Band 4 / 10MHz / QPSK / RB Size 1 Offset 0/ The Worst Test Results for Lowest							
Frequency(MHz)	S	Ant(dBi)	Loss	PMea	Limit	Margin	Polarity
	G.Lev (dBm)			(dBm)	(dBm)	(dBm)	
3429.89	-33.79	12.90	12.56	-33.45	-13.00	-20.45	H
5145.12	-35.33	13.10	16.32	-38.55	-13.00	-25.55	H
6860.21	-33.05	12.33	21.13	-41.85	-13.00	-28.85	H
3429.89	-35.75	12.90	12.56	-35.41	-13.00	-22.41	V
5145.12	-33.98	13.10	16.32	-37.20	-13.00	-24.20	V
6860.21	-32.01	12.33	21.13	-40.81	-13.00	-27.81	V
LTE Band 4 / 10MHz / QPSK / RB Size 1 Offset 0/ The Worst Test Results for Middle							
Frequency(MHz)	S	Ant(dBi)	Loss	PMea	Limit	Margin	Polarity
	G.Lev (dBm)			(dBm)	(dBm)	(dBm)	
3464.39	-34.73	12.90	12.56	-34.39	-13.00	-21.39	H
5196.78	-34.69	13.10	16.32	-37.91	-13.00	-24.91	H
6929.48	-33.46	12.33	21.13	-42.26	-13.00	-29.26	H
3464.39	-35.03	12.90	12.56	-34.69	-13.00	-21.69	V
5196.78	-35.14	13.10	16.32	-38.36	-13.00	-25.36	V
6929.48	-33.11	12.33	21.13	-41.91	-13.00	-28.91	V
LTE Band 4 / 10MHz / QPSK / RB Size 1 Offset 0/ The Worst Test Results for Highest							
Frequency(MHz)	S	Ant(dBi)	Loss	PMea	Limit	Margin	Polarity
	G.Lev (dBm)			(dBm)	(dBm)	(dBm)	
3500.34	-33.77	12.90	12.56	-33.43	-13.00	-20.43	H
5250.28	-34.29	13.10	16.32	-37.51	-13.00	-24.51	H
6999.70	-33.16	12.33	21.13	-41.96	-13.00	-28.96	H
3500.34	-35.47	12.90	12.56	-35.13	-13.00	-22.13	V
5250.28	-33.87	13.10	16.32	-37.09	-13.00	-24.09	V
6999.70	-32.46	12.33	21.13	-41.26	-13.00	-28.26	V



LTE Band 4 / 15MHz / QPSK / RB Size 1 Offset 0/ The Worst Test Results for Lowest							
Frequency(MHz)	S G.Lev (dBm)	Ant(dBi)	Loss	PMea	Limit	Margin	Polarity
				(dBm)	(dBm)	(dBm)	
3434.82	-33.90	12.90	12.56	-33.56	-13.00	-20.56	H
5152.32	-34.05	13.10	16.32	-37.27	-13.00	-24.27	H
6870.75	-32.88	12.33	21.13	-41.68	-13.00	-28.68	H
3434.82	-34.94	12.90	12.56	-34.60	-13.00	-21.60	V
5152.32	-34.10	13.10	16.32	-37.32	-13.00	-24.32	V
6870.75	-32.30	12.33	21.13	-41.10	-13.00	-28.10	V
LTE Band 4 / 15MHz / QPSK / RB Size 1 Offset 0/ The Worst Test Results for Middle							
Frequency(MHz)	S G.Lev (dBm)	Ant(dBi)	Loss	PMea	Limit	Margin	Polarity
				(dBm)	(dBm)	(dBm)	
3464.80	-34.77	12.90	12.56	-34.43	-13.00	-21.43	H
5196.42	-35.21	13.10	16.32	-38.43	-13.00	-25.43	H
6929.98	-32.63	12.33	21.13	-41.43	-13.00	-28.43	H
3464.80	-34.92	12.90	12.56	-34.58	-13.00	-21.58	V
5196.42	-34.32	13.10	16.32	-37.54	-13.00	-24.54	V
6929.98	-32.80	12.33	21.13	-41.60	-13.00	-28.60	V
LTE Band 4 / 15MHz / QPSK / RB Size 1 Offset 0/ The Worst Test Results for Highest							
Frequency(MHz)	S G.Lev (dBm)	Ant(dBi)	Loss	PMea	Limit	Margin	Polarity
				(dBm)	(dBm)	(dBm)	
3495.48	-34.25	12.90	12.56	-33.91	-13.00	-20.91	H
5242.10	-34.87	13.10	16.32	-38.09	-13.00	-25.09	H
6990.19	-33.40	12.33	21.13	-42.20	-13.00	-29.20	H
3495.48	-34.54	12.90	12.56	-34.20	-13.00	-21.20	V
5242.10	-34.90	13.10	16.32	-38.12	-13.00	-25.12	V
6990.19	-32.06	12.33	21.13	-40.86	-13.00	-27.86	V



LTE Band 4 / 20MHz / QPSK / RB Size 1 Offset 0/ The Worst Test Results for Lowest							
Frequency(MHz)	S G.Lev (dBm)	Ant(dBi)	Loss	PMea	Limit	Margin	Polarity
				(dBm)	(dBm)	(dBm)	
3440.12	-34.27	12.90	12.56	-33.93	-13.00	-20.93	H
5160.30	-35.02	13.10	16.32	-38.24	-13.00	-25.24	H
6880.84	-32.47	12.33	21.13	-41.27	-13.00	-28.27	H
3440.12	-34.61	12.90	12.56	-34.27	-13.00	-21.27	V
5160.30	-34.29	13.10	16.32	-37.51	-13.00	-24.51	V
6880.84	-32.00	12.33	21.13	-40.80	-13.00	-27.80	V
LTE Band 4 / 20MHz / QPSK / RB Size 1 Offset 0/ The Worst Test Results for Middle							
Frequency(MHz)	S G.Lev (dBm)	Ant(dBi)	Loss	PMea	Limit	Margin	Polarity
				(dBm)	(dBm)	(dBm)	
3465.00	-34.91	12.90	12.56	-34.57	-13.00	-21.57	H
5196.65	-34.69	13.10	16.32	-37.91	-13.00	-24.91	H
6929.74	-33.54	12.33	21.13	-42.34	-13.00	-29.34	H
3465.00	-35.92	12.90	12.56	-35.58	-13.00	-22.58	V
5196.65	-33.92	13.10	16.32	-37.14	-13.00	-24.14	V
6929.74	-32.29	12.33	21.13	-41.09	-13.00	-28.09	V
LTE Band 4 / 20MHz / QPSK / RB Size 1 Offset 0/ The Worst Test Results for Highest							
Frequency(MHz)	S G.Lev (dBm)	Ant(dBi)	Loss	PMea	Limit	Margin	Polarity
				(dBm)	(dBm)	(dBm)	
3490.57	-34.50	12.90	12.56	-34.16	-13.00	-21.16	H
5235.27	-34.22	13.10	16.32	-37.44	-13.00	-24.44	H
6979.66	-32.18	12.33	21.13	-40.98	-13.00	-27.98	H
3490.57	-35.63	12.90	12.56	-35.29	-13.00	-22.29	V
5235.27	-34.76	13.10	16.32	-37.98	-13.00	-24.98	V
6979.66	-33.18	12.33	21.13	-41.98	-13.00	-28.98	V



LTE Band 5 / 1.4MHz / QPSK / RB Size 1 Offset 0/ The Worst Test Results for Lowest							
Frequency(MHz)	S G.Lev (dBm)	Ant(dBi)	Loss	PMea	Limit	Margin	Polarity
				(dBm)	(dBm)	(dBm)	
1648.65	-34.04	9.56	9.72	-34.20	-13.00	-21.20	H
2473.68	-34.39	10.50	10.86	-34.75	-13.00	-21.75	H
3298.37	-32.95	12.78	11.57	-31.74	-13.00	-18.74	H
1648.65	-35.29	9.56	9.72	-35.45	-13.00	-22.45	V
2473.68	-35.01	10.50	10.86	-35.37	-13.00	-22.37	V
3298.37	-32.35	12.78	11.57	-31.14	-13.00	-18.14	V
LTE Band 5 / 1.4MHz / QPSK / RB Size 1 Offset 0/ The Worst Test Results for Middle							
Frequency(MHz)	S G.Lev (dBm)	Ant(dBi)	Loss	PMea	Limit	Margin	Polarity
				(dBm)	(dBm)	(dBm)	
1672.71	-34.60	9.56	9.72	-34.76	-13.00	-21.76	H
2508.99	-34.44	10.50	10.86	-34.80	-13.00	-21.80	H
3345.78	-32.27	12.78	11.57	-31.06	-13.00	-18.06	H
1672.71	-35.14	9.56	9.72	-35.30	-13.00	-22.30	V
2508.99	-34.85	10.50	10.86	-35.21	-13.00	-22.21	V
3345.78	-32.97	12.78	11.57	-31.76	-13.00	-18.76	V
LTE Band 5 / 1.4MHz / QPSK / RB Size 1 Offset 0/ The Worst Test Results for Highest							
Frequency(MHz)	S G.Lev (dBm)	Ant(dBi)	Loss	PMea	Limit	Margin	Polarity
				(dBm)	(dBm)	(dBm)	
1696.32	-33.63	9.56	9.72	-33.79	-13.00	-20.79	H
2544.45	-34.54	10.50	10.86	-34.90	-13.00	-21.90	H
3392.77	-32.23	12.78	11.57	-31.02	-13.00	-18.02	H
1696.32	-34.74	9.56	9.72	-34.90	-13.00	-21.90	V
2544.45	-34.28	10.50	10.86	-34.64	-13.00	-21.64	V
3392.77	-32.72	12.78	11.57	-31.51	-13.00	-18.51	V



LTE Band 5 / 3MHz / QPSK / RB Size 1 Offset 0/ The Worst Test Results for Lowest							
Frequency(MHz)	S	Ant(dBi)	Loss	PMea	Limit	Margin	Polarity
	G.Lev (dBm)			(dBm)	(dBm)	(dBm)	
1650.02	-33.58	9.56	9.72	-33.74	-13.00	-20.74	H
2475.96	-35.39	10.50	10.86	-35.75	-13.00	-22.75	H
3301.50	-33.37	12.78	11.57	-32.16	-13.00	-19.16	H
1650.02	-35.74	9.56	9.72	-35.90	-13.00	-22.90	V
2475.96	-35.24	10.50	10.86	-35.60	-13.00	-22.60	V
3301.50	-32.14	12.78	11.57	-30.93	-13.00	-17.93	V
LTE Band 5 / 3MHz / QPSK / RB Size 1 Offset 0/ The Worst Test Results for Middle							
Frequency(MHz)	S	Ant(dBi)	Loss	PMea	Limit	Margin	Polarity
	G.Lev (dBm)			(dBm)	(dBm)	(dBm)	
1672.21	-34.69	9.56	9.72	-34.85	-13.00	-21.85	H
2508.69	-34.33	10.50	10.86	-34.69	-13.00	-21.69	H
3345.87	-32.74	12.78	11.57	-31.53	-13.00	-18.53	H
1672.21	-36.00	9.56	9.72	-36.16	-13.00	-23.16	V
2508.69	-34.06	10.50	10.86	-34.42	-13.00	-21.42	V
3345.87	-32.87	12.78	11.57	-31.66	-13.00	-18.66	V
LTE Band 5 / 3MHz / QPSK / RB Size 1 Offset 0/ The Worst Test Results for Highest							
Frequency(MHz)	S	Ant(dBi)	Loss	PMea	Limit	Margin	Polarity
	G.Lev (dBm)			(dBm)	(dBm)	(dBm)	
1694.40	-33.52	9.56	9.72	-33.68	-13.00	-20.68	H
2542.04	-34.58	10.50	10.86	-34.94	-13.00	-21.94	H
3389.27	-33.12	12.78	11.57	-31.91	-13.00	-18.91	H
1694.40	-36.01	9.56	9.72	-36.17	-13.00	-23.17	V
2542.04	-34.55	10.50	10.86	-34.91	-13.00	-21.91	V
3389.27	-32.23	12.78	11.57	-31.02	-13.00	-18.02	V



LTE Band 5 / 5MHz / QPSK / RB Size 1 Offset 0/ The Worst Test Results for Lowest							
Frequency(MHz)	S	Ant(dBi)	Loss	PMea	Limit	Margin	Polarity
	G.Lev (dBm)			(dBm)	(dBm)	(dBm)	
1652.65	-34.68	9.56	9.72	-34.84	-13.00	-21.84	H
2478.94	-34.56	10.50	10.86	-34.92	-13.00	-21.92	H
3305.54	-32.77	12.78	11.57	-31.56	-13.00	-18.56	H
1652.65	-35.49	9.56	9.72	-35.65	-13.00	-22.65	V
2478.94	-34.26	10.50	10.86	-34.62	-13.00	-21.62	V
3305.54	-32.84	12.78	11.57	-31.63	-13.00	-18.63	V
LTE Band 5 / 5MHz / QPSK / RB Size 1 Offset 0/ The Worst Test Results for Middle							
Frequency(MHz)	S	Ant(dBi)	Loss	PMea	Limit	Margin	Polarity
	G.Lev (dBm)			(dBm)	(dBm)	(dBm)	
1672.62	-34.76	9.56	9.72	-34.92	-13.00	-21.92	H
2508.63	-34.99	10.50	10.86	-35.35	-13.00	-22.35	H
3345.26	-32.72	12.78	11.57	-31.51	-13.00	-18.51	H
1672.62	-34.64	9.56	9.72	-34.80	-13.00	-21.80	V
2508.63	-33.83	10.50	10.86	-34.19	-13.00	-21.19	V
3345.26	-31.90	12.78	11.57	-30.69	-13.00	-17.69	V
LTE Band 5 / 5MHz / QPSK / RB Size 1 Offset 0/ The Worst Test Results for Highest							
Frequency(MHz)	S	Ant(dBi)	Loss	PMea	Limit	Margin	Polarity
	G.Lev (dBm)			(dBm)	(dBm)	(dBm)	
1692.14	-34.91	9.56	9.72	-35.07	-13.00	-22.07	H
2538.93	-34.97	10.50	10.86	-35.33	-13.00	-22.33	H
3385.57	-33.21	12.78	11.57	-32.00	-13.00	-19.00	H
1692.14	-34.88	9.56	9.72	-35.04	-13.00	-22.04	V
2538.93	-33.87	10.50	10.86	-34.23	-13.00	-21.23	V
3385.57	-32.89	12.78	11.57	-31.68	-13.00	-18.68	V



LTE Band 5 / 10MHz / QPSK / RB Size 1 Offset 0/ The Worst Test Results for Lowest							
Frequency(MHz)	S G.Lev (dBm)	Ant(dBi)	Loss	PMea	Limit	Margin	Polarity
				(dBm)	(dBm)	(dBm)	
1657.65	-34.09	9.56	9.72	-34.25	-13.00	-21.25	H
2486.22	-34.46	10.50	10.86	-34.82	-13.00	-21.82	H
3315.16	-32.26	12.78	11.57	-31.05	-13.00	-18.05	H
1657.65	-35.88	9.56	9.72	-36.04	-13.00	-23.04	V
2486.22	-34.98	10.50	10.86	-35.34	-13.00	-22.34	V
3315.16	-33.07	12.78	11.57	-31.86	-13.00	-18.86	V
LTE Band 5 / 10MHz / QPSK / RB Size 1 Offset 0/ The Worst Test Results for Middle							
Frequency(MHz)	S G.Lev (dBm)	Ant(dBi)	Loss	PMea	Limit	Margin	Polarity
				(dBm)	(dBm)	(dBm)	
1672.36	-34.77	9.56	9.72	-34.93	-13.00	-21.93	H
2509.06	-35.06	10.50	10.86	-35.42	-13.00	-22.42	H
3345.40	-33.42	12.78	11.57	-32.21	-13.00	-19.21	H
1672.36	-34.92	9.56	9.72	-35.08	-13.00	-22.08	V
2509.06	-34.71	10.50	10.86	-35.07	-13.00	-22.07	V
3345.40	-32.28	12.78	11.57	-31.07	-13.00	-18.07	V
LTE Band 5 / 10MHz / QPSK / RB Size 1 Offset 0/ The Worst Test Results for Highest							
Frequency(MHz)	S G.Lev (dBm)	Ant(dBi)	Loss	PMea	Limit	Margin	Polarity
				(dBm)	(dBm)	(dBm)	
1687.39	-34.81	9.56	9.72	-34.97	-13.00	-21.97	H
2531.25	-34.91	10.50	10.86	-35.27	-13.00	-22.27	H
3375.53	-33.03	12.78	11.57	-31.82	-13.00	-18.82	H
1687.39	-34.96	9.56	9.72	-35.12	-13.00	-22.12	V
2531.25	-34.14	10.50	10.86	-34.50	-13.00	-21.50	V
3375.53	-32.35	12.78	11.57	-31.14	-13.00	-18.14	V



LTE Band 12 / 1.4MHz / QPSK / RB Size 1 Offset 0/ The Worst Test Results for Lowest							
Frequency(MHz)	S G.Lev (dBm)	Ant(dBi)	Loss	PMea	Limit	Margin	Polarity
				(dBm)	(dBm)	(dBm)	
1399.06	-34.27	8.17	9.34	-35.44	-13.00	-22.44	H
2098.99	-34.58	9.53	10.42	-35.47	-13.00	-22.47	H
2798.36	-32.67	11.27	11.12	-32.52	-13.00	-19.52	H
1399.06	-35.84	8.17	9.34	-37.01	-13.00	-24.01	V
2098.99	-35.22	9.53	10.42	-36.11	-13.00	-23.11	V
2798.36	-32.26	11.27	11.12	-32.11	-13.00	-19.11	V
LTE Band 12 / 1.4MHz / QPSK / RB Size 1 Offset 0/ The Worst Test Results for Middle							
Frequency(MHz)	S G.Lev (dBm)	Ant(dBi)	Loss	PMea	Limit	Margin	Polarity
				(dBm)	(dBm)	(dBm)	
1414.93	-33.92	8.17	9.34	-35.09	-13.00	-22.09	H
2122.27	-34.05	9.53	10.42	-34.94	-13.00	-21.94	H
2829.55	-32.31	11.27	11.12	-32.16	-13.00	-19.16	H
1414.93	-35.46	8.17	9.34	-36.63	-13.00	-23.63	V
2122.27	-34.29	9.53	10.42	-35.18	-13.00	-22.18	V
2829.55	-32.29	11.27	11.12	-32.14	-13.00	-19.14	V
LTE Band 12 / 1.4MHz / QPSK / RB Size 1 Offset 0/ The Worst Test Results for Highest							
Frequency(MHz)	S G.Lev (dBm)	Ant(dBi)	Loss	PMea	Limit	Margin	Polarity
				(dBm)	(dBm)	(dBm)	
1430.59	-33.89	8.17	9.34	-35.06	-13.00	-22.06	H
2145.54	-34.39	9.53	10.42	-35.28	-13.00	-22.28	H
2860.83	-32.36	11.27	11.12	-32.21	-13.00	-19.21	H
1430.59	-34.63	8.17	9.34	-35.80	-13.00	-22.80	V
2145.54	-34.87	9.53	10.42	-35.76	-13.00	-22.76	V
2860.83	-33.06	11.27	11.12	-32.91	-13.00	-19.91	V



LTE Band 12 / 3MHz / QPSK / RB Size 1 Offset 0/ The Worst Test Results for Lowest							
Frequency(MHz)	S	Ant(dBi)	Loss	PMea	Limit	Margin	Polarity
	G.Lev (dBm)			(dBm)	(dBm)	(dBm)	
1400.59	-34.72	8.17	9.34	-35.89	-13.00	-22.89	H
2101.04	-34.10	9.53	10.42	-34.99	-13.00	-21.99	H
2801.74	-32.90	11.27	11.12	-32.75	-13.00	-19.75	H
1400.59	-35.11	8.17	9.34	-36.28	-13.00	-23.28	V
2101.04	-35.12	9.53	10.42	-36.01	-13.00	-23.01	V
2801.74	-32.67	11.27	11.12	-32.52	-13.00	-19.52	V
LTE Band 12 / 3MHz / QPSK / RB Size 1 Offset 0/ The Worst Test Results for Middle							
Frequency(MHz)	S	Ant(dBi)	Loss	PMea	Limit	Margin	Polarity
	G.Lev (dBm)			(dBm)	(dBm)	(dBm)	
1414.86	-34.09	8.17	9.34	-35.26	-13.00	-22.26	H
2122.23	-34.33	9.53	10.42	-35.22	-13.00	-22.22	H
2829.90	-33.51	11.27	11.12	-33.36	-13.00	-20.36	H
1414.86	-34.73	8.17	9.34	-35.90	-13.00	-22.90	V
2122.23	-33.94	9.53	10.42	-34.83	-13.00	-21.83	V
2829.90	-32.94	11.27	11.12	-32.79	-13.00	-19.79	V
LTE Band 12 / 3MHz / QPSK / RB Size 1 Offset 0/ The Worst Test Results for Highest							
Frequency(MHz)	S	Ant(dBi)	Loss	PMea	Limit	Margin	Polarity
	G.Lev (dBm)			(dBm)	(dBm)	(dBm)	
1428.51	-33.97	8.17	9.34	-35.14	-13.00	-22.14	H
2143.39	-34.67	9.53	10.42	-35.56	-13.00	-22.56	H
2857.92	-32.95	11.27	11.12	-32.80	-13.00	-19.80	H
1428.51	-35.95	8.17	9.34	-37.12	-13.00	-24.12	V
2143.39	-35.03	9.53	10.42	-35.92	-13.00	-22.92	V
2857.92	-33.17	11.27	11.12	-33.02	-13.00	-20.02	V



LTE Band 12 / 5MHz / QPSK / RB Size 1 Offset 0/ The Worst Test Results for Lowest							
Frequency(MHz)	S	Ant(dBi)	Loss	PMea	Limit	Margin	Polarity
	G.Lev (dBm)			(dBm)	(dBm)	(dBm)	
1402.55	-34.53	8.17	9.34	-35.70	-13.00	-22.70	H
2104.21	-34.44	9.53	10.42	-35.33	-13.00	-22.33	H
2805.79	-33.02	11.27	11.12	-32.87	-13.00	-19.87	H
1402.55	-35.36	8.17	9.34	-36.53	-13.00	-23.53	V
2104.21	-34.38	9.53	10.42	-35.27	-13.00	-22.27	V
2805.79	-32.44	11.27	11.12	-32.29	-13.00	-19.29	V
LTE Band 12 / 5MHz / QPSK / RB Size 1 Offset 0/ The Worst Test Results for Middle							
Frequency(MHz)	S	Ant(dBi)	Loss	PMea	Limit	Margin	Polarity
	G.Lev (dBm)			(dBm)	(dBm)	(dBm)	
1414.53	-33.49	8.17	9.34	-34.66	-13.00	-21.66	H
2122.28	-34.54	9.53	10.42	-35.43	-13.00	-22.43	H
2829.95	-32.76	11.27	11.12	-32.61	-13.00	-19.61	H
1414.53	-34.71	8.17	9.34	-35.88	-13.00	-22.88	V
2122.28	-34.91	9.53	10.42	-35.80	-13.00	-22.80	V
2829.95	-33.06	11.27	11.12	-32.91	-13.00	-19.91	V
LTE Band 12 / 5MHz / QPSK / RB Size 1 Offset 0/ The Worst Test Results for Highest							
Frequency(MHz)	S	Ant(dBi)	Loss	PMea	Limit	Margin	Polarity
	G.Lev (dBm)			(dBm)	(dBm)	(dBm)	
1426.64	-33.46	8.17	9.34	-34.63	-13.00	-21.63	H
2140.44	-34.82	9.53	10.42	-35.71	-13.00	-22.71	H
2853.98	-33.10	11.27	11.12	-32.95	-13.00	-19.95	H
1426.64	-35.15	8.17	9.34	-36.32	-13.00	-23.32	V
2140.44	-34.82	9.53	10.42	-35.71	-13.00	-22.71	V
2853.98	-32.04	11.27	11.12	-31.89	-13.00	-18.89	V



LTE Band 12 / 10MHz / QPSK / RB Size 1 Offset 0/ The Worst Test Results for Lowest							
Frequency(MHz)	S	Ant(dBi)	Loss	PMea	Limit	Margin	Polarity
	G.Lev (dBm)			(dBm)	(dBm)	(dBm)	
1407.85	-34.37	8.17	9.34	-35.54	-13.00	-22.54	H
2111.87	-34.13	9.53	10.42	-35.02	-13.00	-22.02	H
2815.82	-32.15	11.27	11.12	-32.00	-13.00	-19.00	H
1407.85	-35.61	8.17	9.34	-36.78	-13.00	-23.78	V
2111.87	-34.25	9.53	10.42	-35.14	-13.00	-22.14	V
2815.82	-32.58	11.27	11.12	-32.43	-13.00	-19.43	V
LTE Band 12 / 10MHz / QPSK / RB Size 1 Offset 0/ The Worst Test Results for Middle							
Frequency(MHz)	S	Ant(dBi)	Loss	PMea	Limit	Margin	Polarity
	G.Lev (dBm)			(dBm)	(dBm)	(dBm)	
1414.53	-33.90	8.17	9.34	-35.07	-13.00	-22.07	H
2122.30	-34.39	9.53	10.42	-35.28	-13.00	-22.28	H
2829.57	-33.23	11.27	11.12	-33.08	-13.00	-20.08	H
1414.53	-35.80	8.17	9.34	-36.97	-13.00	-23.97	V
2122.30	-34.14	9.53	10.42	-35.03	-13.00	-22.03	V
2829.57	-31.86	11.27	11.12	-31.71	-13.00	-18.71	V
LTE Band 12 / 10MHz / QPSK / RB Size 1 Offset 0/ The Worst Test Results for Highest							
Frequency(MHz)	S	Ant(dBi)	Loss	PMea	Limit	Margin	Polarity
	G.Lev (dBm)			(dBm)	(dBm)	(dBm)	
1421.62	-34.75	8.17	9.34	-35.92	-13.00	-22.92	H
2132.88	-35.15	9.53	10.42	-36.04	-13.00	-23.04	H
2843.69	-33.48	11.27	11.12	-33.33	-13.00	-20.33	H
1421.62	-35.56	8.17	9.34	-36.73	-13.00	-23.73	V
2132.88	-35.09	9.53	10.42	-35.98	-13.00	-22.98	V
2843.69	-32.50	11.27	11.12	-32.35	-13.00	-19.35	V



LTE Band 13 / 5MHz / QPSK / RB Size 1 Offset 0/ The Worst Test Results for Lowest							
Frequency(MHz)	S	Ant(dBi)	Loss	PMea	Limit	Margin	Polarity
	G.Lev (dBm)			(dBm)	(dBm)	(dBm)	
1559.31	-48.44	9.56	9.72	-48.60	-40.00	-8.60	H
2338.47	-47.33	10.50	10.86	-47.69	-13.00	-34.69	H
3118.26	-46.39	12.78	11.57	-45.18	-13.00	-32.18	H
1559.31	-48.36	9.56	9.72	-48.52	-40.00	-8.52	V
2338.47	-47.40	10.50	10.86	-47.76	-13.00	-34.76	V
3118.26	-45.83	12.78	11.57	-44.62	-13.00	-31.62	V
LTE Band 13 / 5MHz / QPSK / RB Size 1 Offset 0/ The Worst Test Results for Middle							
Frequency(MHz)	S	Ant(dBi)	Loss	PMea	Limit	Margin	Polarity
	G.Lev (dBm)			(dBm)	(dBm)	(dBm)	
1564.17	-48.89	9.56	9.72	-49.05	-40.00	-9.05	H
2345.65	-46.71	10.50	10.86	-47.07	-13.00	-34.07	H
3127.79	-46.57	12.78	11.57	-45.36	-13.00	-32.36	H
1564.17	-48.39	9.56	9.72	-48.55	-40.00	-8.55	V
2345.65	-47.32	10.50	10.86	-47.68	-13.00	-34.68	V
3127.79	-46.26	12.78	11.57	-45.05	-13.00	-32.05	V
LTE Band 13 / 5MHz / QPSK / RB Size 1 Offset 0/ The Worst Test Results for Highest							
Frequency(MHz)	S	Ant(dBi)	Loss	PMea	Limit	Margin	Polarity
	G.Lev (dBm)			(dBm)	(dBm)	(dBm)	
1568.82	-48.40	9.56	9.72	-48.56	-40.00	-8.56	H
2353.39	-47.05	10.50	10.86	-47.41	-13.00	-34.41	H
3138.25	-45.50	12.78	11.57	-44.29	-13.00	-31.29	H
1568.82	-48.78	9.56	9.72	-48.94	-40.00	-8.94	V
2353.39	-46.48	10.50	10.86	-46.84	-13.00	-33.84	V
3138.25	-45.15	12.78	11.57	-43.94	-13.00	-30.94	V
LTE Band 13 / 10MHz / QPSK / RB Size 1 Offset 0/ The Worst Test Results for Middle							
Frequency(MHz)	S	Ant(dBi)	Loss	PMea	Limit	Margin	Polarity
	G.Lev (dBm)			(dBm)	(dBm)	(dBm)	
1564.00	-47.62	9.56	9.72	-47.78	-40.00	-7.78	H
2346.11	-46.80	10.50	10.86	-47.16	-13.00	-34.16	H
3127.86	-45.32	12.78	11.57	-44.11	-13.00	-31.11	H
1564.00	-47.80	9.56	9.72	-47.96	-40.00	-7.96	V
2346.11	-46.34	10.50	10.86	-46.70	-13.00	-33.70	V
3127.86	-46.02	12.78	11.57	-44.81	-13.00	-31.81	V



LTE Band 25 / 1.4MHz / QPSK / RB Size 1 Offset 0/ The Worst Test Results for Lowest							
Frequency(MHz)	S	Ant(dBi)	Loss	PMea	Limit	Margin	Polarity
	G.Lev (dBm)			(dBm)	(dBm)	(dBm)	
3701.15	-34.56	12.60	12.93	-34.89	-13.00	-21.89	H
5551.98	-35.00	13.10	17.11	-39.01	-13.00	-26.01	H
7402.82	-32.86	11.50	22.20	-43.56	-13.00	-30.56	H
3701.15	-35.49	12.60	12.93	-35.82	-13.00	-22.82	V
5551.98	-34.04	13.10	17.11	-38.05	-13.00	-25.05	V
7402.82	-32.67	11.50	22.20	-43.37	-13.00	-30.37	V
LTE Band 25 / 1.4MHz / QPSK / RB Size 1 Offset 0/ The Worst Test Results for Middle							
Frequency(MHz)	S	Ant(dBi)	Loss	PMea	Limit	Margin	Polarity
	G.Lev (dBm)			(dBm)	(dBm)	(dBm)	
3759.88	-33.76	12.60	12.93	-34.09	-13.00	-21.09	H
5640.02	-35.05	13.10	17.11	-39.06	-13.00	-26.06	H
7520.24	-32.97	11.50	22.20	-43.67	-13.00	-30.67	H
3759.88	-34.68	12.60	12.93	-35.01	-13.00	-22.01	V
5640.02	-34.23	13.10	17.11	-38.24	-13.00	-25.24	V
7520.24	-32.08	11.50	22.20	-42.78	-13.00	-29.78	V
LTE Band 25 / 1.4MHz / QPSK / RB Size 1 Offset 0/ The Worst Test Results for Highest							
Frequency(MHz)	S	Ant(dBi)	Loss	PMea	Limit	Margin	Polarity
	G.Lev (dBm)			(dBm)	(dBm)	(dBm)	
3818.55	-34.40	12.60	12.93	-34.73	-13.00	-21.73	H
5727.47	-34.19	13.10	17.11	-38.20	-13.00	-25.20	H
7637.21	-32.74	11.50	22.20	-43.44	-13.00	-30.44	H
3818.55	-35.57	12.60	12.93	-35.90	-13.00	-22.90	V
5727.47	-34.75	13.10	17.11	-38.76	-13.00	-25.76	V
7637.21	-32.79	11.50	22.20	-43.49	-13.00	-30.49	V



LTE Band 25 / 3MHz / QPSK / RB Size 1 Offset 0/ The Worst Test Results for Lowest							
Frequency(MHz)	S G.Lev (dBm)	Ant(dBi)	Loss	PMea	Limit	Margin	Polarity
	(dBm)			(dBm)	(dBm)		
3703.27	-33.54	12.60	12.93	-33.87	-13.00	-20.87	H
5554.23	-34.21	13.10	17.11	-38.22	-13.00	-25.22	H
7405.97	-32.34	11.50	22.20	-43.04	-13.00	-30.04	H
3703.27	-34.70	12.60	12.93	-35.03	-13.00	-22.03	V
5554.23	-34.29	13.10	17.11	-38.30	-13.00	-25.30	V
7405.97	-32.66	11.50	22.20	-43.36	-13.00	-30.36	V
LTE Band 25 / 3MHz / QPSK / RB Size 1 Offset 0/ The Worst Test Results for Middle							
Frequency(MHz)	S G.Lev (dBm)	Ant(dBi)	Loss	PMea	Limit	Margin	Polarity
	(dBm)			(dBm)	(dBm)		
3760.15	-33.65	12.60	12.93	-33.98	-13.00	-20.98	H
5640.22	-34.93	13.10	17.11	-38.94	-13.00	-25.94	H
7520.00	-33.34	11.50	22.20	-44.04	-13.00	-31.04	H
3760.15	-35.36	12.60	12.93	-35.69	-13.00	-22.69	V
5640.22	-34.59	13.10	17.11	-38.60	-13.00	-25.60	V
7520.00	-32.48	11.50	22.20	-43.18	-13.00	-30.18	V
LTE Band 25 / 3MHz / QPSK / RB Size 1 Offset 0/ The Worst Test Results for Highest							
Frequency(MHz)	S G.Lev (dBm)	Ant(dBi)	Loss	PMea	Limit	Margin	Polarity
	(dBm)			(dBm)	(dBm)		
3817.29	-34.01	12.60	12.93	-34.34	-13.00	-21.34	H
5725.56	-34.61	13.10	17.11	-38.62	-13.00	-25.62	H
7634.26	-33.05	11.50	22.20	-43.75	-13.00	-30.75	H
3817.29	-35.32	12.60	12.93	-35.65	-13.00	-22.65	V
5725.56	-35.08	13.10	17.11	-39.09	-13.00	-26.09	V
7634.26	-32.98	11.50	22.20	-43.68	-13.00	-30.68	V



LTE Band 25 / 5MHz / QPSK / RB Size 1 Offset 0/ The Worst Test Results for Lowest							
Frequency(MHz)	S G.Lev (dBm)	Ant(dBi)	Loss	PMea	Limit	Margin	Polarity
				(dBm)	(dBm)	(dBm)	
3705.24	-33.69	12.60	12.93	-34.02	-13.00	-21.02	H
5557.40	-35.43	13.10	17.11	-39.44	-13.00	-26.44	H
7409.97	-32.70	11.50	22.20	-43.40	-13.00	-30.40	H
3705.24	-35.86	12.60	12.93	-36.19	-13.00	-23.19	V
5557.40	-33.86	13.10	17.11	-37.87	-13.00	-24.87	V
7409.97	-31.73	11.50	22.20	-42.43	-13.00	-29.43	V
LTE Band 25 / 5MHz / QPSK / RB Size 1 Offset 0/ The Worst Test Results for Middle							
Frequency(MHz)	S G.Lev (dBm)	Ant(dBi)	Loss	PMea	Limit	Margin	Polarity
				(dBm)	(dBm)	(dBm)	
3760.11	-34.17	12.60	12.93	-34.50	-13.00	-21.50	H
5640.24	-34.96	13.10	17.11	-38.97	-13.00	-25.97	H
7519.81	-33.24	11.50	22.20	-43.94	-13.00	-30.94	H
3760.11	-35.55	12.60	12.93	-35.88	-13.00	-22.88	V
5640.24	-34.23	13.10	17.11	-38.24	-13.00	-25.24	V
7519.81	-33.00	11.50	22.20	-43.70	-13.00	-30.70	V
LTE Band 25 / 5MHz / QPSK / RB Size 1 Offset 0/ The Worst Test Results for Highest							
Frequency(MHz)	S G.Lev (dBm)	Ant(dBi)	Loss	PMea	Limit	Margin	Polarity
				(dBm)	(dBm)	(dBm)	
3814.97	-33.89	12.60	12.93	-34.22	-13.00	-21.22	H
5722.25	-35.24	13.10	17.11	-39.25	-13.00	-26.25	H
7630.14	-33.01	11.50	22.20	-43.71	-13.00	-30.71	H
3814.97	-35.40	12.60	12.93	-35.73	-13.00	-22.73	V
5722.25	-34.19	13.10	17.11	-38.20	-13.00	-25.20	V
7630.14	-32.92	11.50	22.20	-43.62	-13.00	-30.62	V



LTE Band 25 / 10MHz / QPSK / RB Size 1 Offset 0/ The Worst Test Results for Lowest							
Frequency(MHz)	S G.Lev (dBm)	Ant(dBi)	Loss	PMea	Limit	Margin	Polarity
				(dBm)	(dBm)	(dBm)	
3710.45	-34.19	12.60	12.93	-34.52	-13.00	-21.52	H
5565.40	-34.81	13.10	17.11	-38.82	-13.00	-25.82	H
7419.96	-32.74	11.50	22.20	-43.44	-13.00	-30.44	H
3710.45	-34.77	12.60	12.93	-35.10	-13.00	-22.10	V
5565.40	-34.61	13.10	17.11	-38.62	-13.00	-25.62	V
7419.96	-32.72	11.50	22.20	-43.42	-13.00	-30.42	V
LTE Band 25 / 10MHz / QPSK / RB Size 1 Offset 0/ The Worst Test Results for Middle							
Frequency(MHz)	S G.Lev (dBm)	Ant(dBi)	Loss	PMea	Limit	Margin	Polarity
				(dBm)	(dBm)	(dBm)	
3759.85	-34.71	12.60	12.93	-35.04	-13.00	-22.04	H
5640.20	-35.00	13.10	17.11	-39.01	-13.00	-26.01	H
7519.90	-32.24	11.50	22.20	-42.94	-13.00	-29.94	H
3759.85	-34.86	12.60	12.93	-35.19	-13.00	-22.19	V
5640.20	-33.76	13.10	17.11	-37.77	-13.00	-24.77	V
7519.90	-32.06	11.50	22.20	-42.76	-13.00	-29.76	V
LTE Band 25 / 10MHz / QPSK / RB Size 1 Offset 0/ The Worst Test Results for Highest							
Frequency(MHz)	S G.Lev (dBm)	Ant(dBi)	Loss	PMea	Limit	Margin	Polarity
				(dBm)	(dBm)	(dBm)	
3810.41	-34.76	12.60	12.93	-35.09	-13.00	-22.09	H
5715.05	-34.90	13.10	17.11	-38.91	-13.00	-25.91	H
7620.28	-32.64	11.50	22.20	-43.34	-13.00	-30.34	H
3810.41	-35.44	12.60	12.93	-35.77	-13.00	-22.77	V
5715.05	-34.41	13.10	17.11	-38.42	-13.00	-25.42	V
7620.28	-31.77	11.50	22.20	-42.47	-13.00	-29.47	V



LTE Band 25 / 15MHz / QPSK / RB Size 1 Offset 0/ The Worst Test Results for Lowest							
Frequency(MHz)	S G.Lev (dBm)	Ant(dBi)	Loss	PMea	Limit	Margin	Polarity
				(dBm)	(dBm)	(dBm)	
3714.93	-34.56	12.60	12.93	-34.89	-13.00	-21.89	H
5572.48	-35.41	13.10	17.11	-39.42	-13.00	-26.42	H
7430.79	-32.57	11.50	22.20	-43.27	-13.00	-30.27	H
3714.93	-35.96	12.60	12.93	-36.29	-13.00	-23.29	V
5572.48	-35.08	13.10	17.11	-39.09	-13.00	-26.09	V
7430.79	-32.09	11.50	22.20	-42.79	-13.00	-29.79	V
LTE Band 25 / 15MHz / QPSK / RB Size 1 Offset 0/ The Worst Test Results for Middle							
Frequency(MHz)	S G.Lev (dBm)	Ant(dBi)	Loss	PMea	Limit	Margin	Polarity
				(dBm)	(dBm)	(dBm)	
3759.92	-34.25	12.60	12.93	-34.58	-13.00	-21.58	H
5640.10	-34.07	13.10	17.11	-38.08	-13.00	-25.08	H
7519.88	-32.63	11.50	22.20	-43.33	-13.00	-30.33	H
3759.92	-34.92	12.60	12.93	-35.25	-13.00	-22.25	V
5640.10	-34.24	13.10	17.11	-38.25	-13.00	-25.25	V
7519.88	-32.97	11.50	22.20	-43.67	-13.00	-30.67	V
LTE Band 25 / 15MHz / QPSK / RB Size 1 Offset 0/ The Worst Test Results for Highest							
Frequency(MHz)	S G.Lev (dBm)	Ant(dBi)	Loss	PMea	Limit	Margin	Polarity
				(dBm)	(dBm)	(dBm)	
3804.99	-34.12	12.60	12.93	-34.45	-13.00	-21.45	H
5707.52	-35.29	13.10	17.11	-39.30	-13.00	-26.30	H
7609.91	-32.53	11.50	22.20	-43.23	-13.00	-30.23	H
3804.99	-34.54	12.60	12.93	-34.87	-13.00	-21.87	V
5707.52	-34.95	13.10	17.11	-38.96	-13.00	-25.96	V
7609.91	-32.29	11.50	22.20	-42.99	-13.00	-29.99	V



LTE Band 25 / 20MHz / QPSK / RB Size 1 Offset 0/ The Worst Test Results for Lowest							
Frequency(MHz)	S G.Lev (dBm)	Ant(dBi)	Loss	PMea	Limit	Margin	Polarity
				(dBm)	(dBm)	(dBm)	
3720.45	-34.44	12.60	12.93	-34.77	-13.00	-21.77	H
5580.42	-34.27	13.10	17.11	-38.28	-13.00	-25.28	H
7439.79	-33.10	11.50	22.20	-43.80	-13.00	-30.80	H
3720.45	-34.76	12.60	12.93	-35.09	-13.00	-22.09	V
5580.42	-35.20	13.10	17.11	-39.21	-13.00	-26.21	V
7439.79	-32.16	11.50	22.20	-42.86	-13.00	-29.86	V
LTE Band 25 / 20MHz / QPSK / RB Size 1 Offset 0/ The Worst Test Results for Middle							
Frequency(MHz)	S G.Lev (dBm)	Ant(dBi)	Loss	PMea	Limit	Margin	Polarity
				(dBm)	(dBm)	(dBm)	
3760.07	-34.45	12.60	12.93	-34.78	-13.00	-21.78	H
5640.21	-35.45	13.10	17.11	-39.46	-13.00	-26.46	H
7519.91	-33.26	11.50	22.20	-43.96	-13.00	-30.96	H
3760.07	-34.75	12.60	12.93	-35.08	-13.00	-22.08	V
5640.21	-33.95	13.10	17.11	-37.96	-13.00	-24.96	V
7519.91	-32.43	11.50	22.20	-43.13	-13.00	-30.13	V
LTE Band 25 / 20MHz / QPSK / RB Size 1 Offset 0/ The Worst Test Results for Highest							
Frequency(MHz)	S G.Lev (dBm)	Ant(dBi)	Loss	PMea	Limit	Margin	Polarity
				(dBm)	(dBm)	(dBm)	
3799.81	-34.16	12.60	12.93	-34.49	-13.00	-21.49	H
5700.13	-35.39	13.10	17.11	-39.40	-13.00	-26.40	H
7600.14	-32.77	11.50	22.20	-43.47	-13.00	-30.47	H
3799.81	-35.49	12.60	12.93	-35.82	-13.00	-22.82	V
5700.13	-33.76	13.10	17.11	-37.77	-13.00	-24.77	V
7600.14	-33.01	11.50	22.20	-43.71	-13.00	-30.71	V



Part22

LTE Band 26 / 1.4MHz / QPSK / RB Size 1 Offset 0/ The Worst Test Results for Lowest							
Frequency(MHz)	S G.Lev (dBm)	Ant(dBi)	Loss	PMea	Limit	Margin	Polarity
				(dBm)	(dBm)	(dBm)	
1649.40	-34.32	9.56	9.72	-34.48	-13.00	-21.48	H
2473.50	-34.29	10.50	10.86	-34.65	-13.00	-21.65	H
3298.57	-32.66	12.78	11.57	-31.45	-13.00	-18.45	H
1649.40	-35.21	9.56	9.72	-35.37	-13.00	-22.37	V
2473.50	-34.49	10.50	10.86	-34.85	-13.00	-21.85	V
3298.57	-32.41	12.78	11.57	-31.20	-13.00	-18.20	V
LTE Band 26 / 1.4MHz / QPSK / RB Size 1 Offset 0/ The Worst Test Results for Middle							
Frequency(MHz)	S G.Lev (dBm)	Ant(dBi)	Loss	PMea	Limit	Margin	Polarity
				(dBm)	(dBm)	(dBm)	
1673.05	-34.21	9.56	9.72	-34.37	-13.00	-21.37	H
2508.92	-35.04	10.50	10.86	-35.40	-13.00	-22.40	H
3346.01	-32.69	12.78	11.57	-31.48	-13.00	-18.48	H
1673.05	-34.96	9.56	9.72	-35.12	-13.00	-22.12	V
2508.92	-34.41	10.50	10.86	-34.77	-13.00	-21.77	V
3346.01	-32.42	12.78	11.57	-31.21	-13.00	-18.21	V
LTE Band 26 / 1.4MHz / QPSK / RB Size 1 Offset 0/ The Worst Test Results for Highest							
Frequency(MHz)	S G.Lev (dBm)	Ant(dBi)	Loss	PMea	Limit	Margin	Polarity
				(dBm)	(dBm)	(dBm)	
1696.52	-33.93	9.56	9.72	-34.09	-13.00	-21.09	H
2544.90	-34.60	10.50	10.86	-34.96	-13.00	-21.96	H
3393.01	-32.27	12.78	11.57	-31.06	-13.00	-18.06	H
1696.52	-34.87	9.56	9.72	-35.03	-13.00	-22.03	V
2544.90	-34.26	10.50	10.86	-34.62	-13.00	-21.62	V
3393.01	-31.87	12.78	11.57	-30.66	-13.00	-17.66	V



LTE Band 26 / 3MHz / QPSK / RB Size 1 Offset 0/ The Worst Test Results for Lowest							
Frequency(MHz)	S G.Lev (dBm)	Ant(dBi)	Loss	PMea	Limit	Margin	Polarity
				(dBm)	(dBm)	(dBm)	
1651.41	-34.81	9.56	9.72	-34.97	-13.00	-21.97	H
2476.48	-34.66	10.50	10.86	-35.02	-13.00	-22.02	H
3301.49	-32.95	12.78	11.57	-31.74	-13.00	-18.74	H
1651.41	-34.65	9.56	9.72	-34.81	-13.00	-21.81	V
2476.48	-34.80	10.50	10.86	-35.16	-13.00	-22.16	V
3301.49	-32.17	12.78	11.57	-30.96	-13.00	-17.96	V
LTE Band 26 / 3MHz / QPSK / RB Size 1 Offset 0/ The Worst Test Results for Middle							
Frequency(MHz)	S G.Lev (dBm)	Ant(dBi)	Loss	PMea	Limit	Margin	Polarity
				(dBm)	(dBm)	(dBm)	
1673.08	-34.88	9.56	9.72	-35.04	-13.00	-22.04	H
2509.22	-34.05	10.50	10.86	-34.41	-13.00	-21.41	H
3345.95	-32.82	12.78	11.57	-31.61	-13.00	-18.61	H
1673.08	-34.82	9.56	9.72	-34.98	-13.00	-21.98	V
2509.22	-33.86	10.50	10.86	-34.22	-13.00	-21.22	V
3345.95	-31.78	12.78	11.57	-30.57	-13.00	-17.57	V
LTE Band 26 / 3MHz / QPSK / RB Size 1 Offset 0/ The Worst Test Results for Highest							
Frequency(MHz)	S G.Lev (dBm)	Ant(dBi)	Loss	PMea	Limit	Margin	Polarity
				(dBm)	(dBm)	(dBm)	
1695.45	-33.68	9.56	9.72	-33.84	-13.00	-20.84	H
2542.33	-35.31	10.50	10.86	-35.67	-13.00	-22.67	H
3390.21	-32.78	12.78	11.57	-31.57	-13.00	-18.57	H
1695.45	-35.67	9.56	9.72	-35.83	-13.00	-22.83	V
2542.33	-34.14	10.50	10.86	-34.50	-13.00	-21.50	V
3390.21	-32.17	12.78	11.57	-30.96	-13.00	-17.96	V



LTE Band 26 / 5MHz / QPSK / RB Size 1 Offset 0/ The Worst Test Results for Lowest							
Frequency(MHz)	S G.Lev (dBm)	Ant(dBi)	Loss	PMea	Limit	Margin	Polarity
				(dBm)	(dBm)	(dBm)	
1652.94	-33.89	9.56	9.72	-34.05	-13.00	-21.05	H
2479.52	-34.17	10.50	10.86	-34.53	-13.00	-21.53	H
3306.59	-32.23	12.78	11.57	-31.02	-13.00	-18.02	H
1652.94	-35.18	9.56	9.72	-35.34	-13.00	-22.34	V
2479.52	-33.88	10.50	10.86	-34.24	-13.00	-21.24	V
3306.59	-31.76	12.78	11.57	-30.55	-13.00	-17.55	V
LTE Band 26 / 5MHz / QPSK / RB Size 1 Offset 0/ The Worst Test Results for Middle							
Frequency(MHz)	S G.Lev (dBm)	Ant(dBi)	Loss	PMea	Limit	Margin	Polarity
				(dBm)	(dBm)	(dBm)	
1673.03	-33.95	9.56	9.72	-34.11	-13.00	-21.11	H
2509.25	-34.87	10.50	10.86	-35.23	-13.00	-22.23	H
3346.04	-33.32	12.78	11.57	-32.11	-13.00	-19.11	H
1673.03	-35.36	9.56	9.72	-35.52	-13.00	-22.52	V
2509.25	-34.43	10.50	10.86	-34.79	-13.00	-21.79	V
3346.04	-32.12	12.78	11.57	-30.91	-13.00	-17.91	V
LTE Band 26 / 5MHz / QPSK / RB Size 1 Offset 0/ The Worst Test Results for Highest							
Frequency(MHz)	S G.Lev (dBm)	Ant(dBi)	Loss	PMea	Limit	Margin	Polarity
				(dBm)	(dBm)	(dBm)	
1693.47	-34.10	9.56	9.72	-34.26	-13.00	-21.26	H
2539.31	-34.32	10.50	10.86	-34.68	-13.00	-21.68	H
3386.19	-33.18	12.78	11.57	-31.97	-13.00	-18.97	H
1693.47	-35.07	9.56	9.72	-35.23	-13.00	-22.23	V
2539.31	-33.95	10.50	10.86	-34.31	-13.00	-21.31	V
3386.19	-32.90	12.78	11.57	-31.69	-13.00	-18.69	V



LTE Band 26 / 10MHz / QPSK / RB Size 1 Offset 0/ The Worst Test Results for Lowest							
Frequency(MHz)	S	Ant(dBi)	Loss	PMea	Limit	Margin	Polarity
	G.Lev (dBm)			(dBm)	(dBm)	(dBm)	
1658.07	-34.65	9.56	9.72	-34.81	-13.00	-21.81	H
2486.23	-35.21	10.50	10.86	-35.57	-13.00	-22.57	H
3315.87	-33.32	12.78	11.57	-32.11	-13.00	-19.11	H
1658.07	-35.07	9.56	9.72	-35.23	-13.00	-22.23	V
2486.23	-34.08	10.50	10.86	-34.44	-13.00	-21.44	V
3315.87	-32.15	12.78	11.57	-30.94	-13.00	-17.94	V
LTE Band 26 / 10MHz / QPSK / RB Size 1 Offset 0/ The Worst Test Results for Middle							
Frequency(MHz)	S	Ant(dBi)	Loss	PMea	Limit	Margin	Polarity
	G.Lev (dBm)			(dBm)	(dBm)	(dBm)	
1672.79	-33.85	9.56	9.72	-34.01	-13.00	-21.01	H
2509.21	-34.44	10.50	10.86	-34.80	-13.00	-21.80	H
3345.93	-33.42	12.78	11.57	-32.21	-13.00	-19.21	H
1672.79	-34.74	9.56	9.72	-34.90	-13.00	-21.90	V
2509.21	-34.53	10.50	10.86	-34.89	-13.00	-21.89	V
3345.93	-32.39	12.78	11.57	-31.18	-13.00	-18.18	V
LTE Band 26 / 10MHz / QPSK / RB Size 1 Offset 0/ The Worst Test Results for Highest							
Frequency(MHz)	S	Ant(dBi)	Loss	PMea	Limit	Margin	Polarity
	G.Lev (dBm)			(dBm)	(dBm)	(dBm)	
1688.33	-33.69	9.56	9.72	-33.85	-13.00	-20.85	H
2532.42	-34.78	10.50	10.86	-35.14	-13.00	-22.14	H
3376.18	-32.70	12.78	11.57	-31.49	-13.00	-18.49	H
1688.33	-35.40	9.56	9.72	-35.56	-13.00	-22.56	V
2532.42	-35.02	10.50	10.86	-35.38	-13.00	-22.38	V
3376.18	-32.08	12.78	11.57	-30.87	-13.00	-17.87	V



LTE Band 26 / 15MHz / QPSK / RB Size 1 Offset 0/ The Worst Test Results for Lowest							
Frequency(MHz)	S G.Lev (dBm)	Ant(dBi)	Loss	PMea	Limit	Margin	Polarity
				(dBm)	(dBm)	(dBm)	
1663.18	-33.89	9.56	9.72	-34.05	-13.00	-21.05	H
2494.43	-34.99	10.50	10.86	-35.35	-13.00	-22.35	H
3325.58	-32.90	12.78	11.57	-31.69	-13.00	-18.69	H
1663.18	-35.81	9.56	9.72	-35.97	-13.00	-22.97	V
2494.43	-34.28	10.50	10.86	-34.64	-13.00	-21.64	V
3325.58	-32.51	12.78	11.57	-31.30	-13.00	-18.30	V
LTE Band 26 / 15MHz / QPSK / RB Size 1 Offset 0/ The Worst Test Results for Middle							
Frequency(MHz)	S G.Lev (dBm)	Ant(dBi)	Loss	PMea	Limit	Margin	Polarity
				(dBm)	(dBm)	(dBm)	
1672.93	-34.89	9.56	9.72	-35.05	-13.00	-22.05	H
2508.92	-34.73	10.50	10.86	-35.09	-13.00	-22.09	H
3345.83	-32.54	12.78	11.57	-31.33	-13.00	-18.33	H
1672.93	-35.50	9.56	9.72	-35.66	-13.00	-22.66	V
2508.92	-34.35	10.50	10.86	-34.71	-13.00	-21.71	V
3345.83	-32.27	12.78	11.57	-31.06	-13.00	-18.06	V
LTE Band 26 / 15MHz / QPSK / RB Size 1 Offset 0/ The Worst Test Results for Highest							
Frequency(MHz)	S G.Lev (dBm)	Ant(dBi)	Loss	PMea	Limit	Margin	Polarity
				(dBm)	(dBm)	(dBm)	
1683.34	-33.95	9.56	9.72	-34.11	-13.00	-21.11	H
2524.33	-34.08	10.50	10.86	-34.44	-13.00	-21.44	H
3366.43	-33.27	12.78	11.57	-32.06	-13.00	-19.06	H
1683.34	-35.81	9.56	9.72	-35.97	-13.00	-22.97	V
2524.33	-34.85	10.50	10.86	-35.21	-13.00	-22.21	V
3366.43	-33.15	12.78	11.57	-31.94	-13.00	-18.94	V



Part90

LTE Band 26 / 1.4MHz / QPSK / RB Size 1 Offset 0/ The Worst Test Results for Lowest							
Frequency(MHz)	S G.Lev (dBm)	Ant(dBi)	Loss	PMea	Limit	Margin	Polarity
				(dBm)	(dBm)	(dBm)	
1629.39	-34.18	9.56	9.72	-34.34	-13.00	-21.34	H
2444.22	-35.07	10.50	10.86	-35.43	-13.00	-22.43	H
3258.85	-32.95	12.78	11.57	-31.74	-13.00	-18.74	H
1629.39	-35.05	9.56	9.72	-35.21	-13.00	-22.21	V
2444.22	-34.19	10.50	10.86	-34.55	-13.00	-21.55	V
3258.85	-33.08	12.78	11.57	-31.87	-13.00	-18.87	V
LTE Band 26 / 1.4MHz / QPSK / RB Size 1 Offset 0/ The Worst Test Results for Middle							
Frequency(MHz)	S G.Lev (dBm)	Ant(dBi)	Loss	PMea	Limit	Margin	Polarity
				(dBm)	(dBm)	(dBm)	
1637.95	-34.46	9.56	9.72	-34.62	-13.00	-21.62	H
2457.13	-34.83	10.50	10.86	-35.19	-13.00	-22.19	H
3276.00	-32.61	12.78	11.57	-31.40	-13.00	-18.40	H
1637.95	-35.92	9.56	9.72	-36.08	-13.00	-23.08	V
2457.13	-34.97	10.50	10.86	-35.33	-13.00	-22.33	V
3276.00	-32.78	12.78	11.57	-31.57	-13.00	-18.57	V
LTE Band 26 / 1.4MHz / QPSK / RB Size 1 Offset 0/ The Worst Test Results for Highest							
Frequency(MHz)	S G.Lev (dBm)	Ant(dBi)	Loss	PMea	Limit	Margin	Polarity
				(dBm)	(dBm)	(dBm)	
1646.37	-34.78	9.56	9.72	-34.94	-13.00	-21.94	H
2469.90	-34.97	10.50	10.86	-35.33	-13.00	-22.33	H
3292.96	-32.44	12.78	11.57	-31.23	-13.00	-18.23	H
1646.37	-35.55	9.56	9.72	-35.71	-13.00	-22.71	V
2469.90	-35.05	10.50	10.86	-35.41	-13.00	-22.41	V
3292.96	-32.19	12.78	11.57	-30.98	-13.00	-17.98	V



LTE Band 26 / 3MHz / QPSK / RB Size 1 Offset 0/ The Worst Test Results for Lowest							
Frequency(MHz)	S G.Lev (dBm)	Ant(dBi)	Loss	PMea	Limit	Margin	Polarity
				(dBm)	(dBm)	(dBm)	
1630.99	-34.16	9.56	9.72	-34.32	-13.00	-21.32	H
2446.60	-35.10	10.50	10.86	-35.46	-13.00	-22.46	H
3262.10	-32.36	12.78	11.57	-31.15	-13.00	-18.15	H
1630.99	-35.85	9.56	9.72	-36.01	-13.00	-23.01	V
2446.60	-34.62	10.50	10.86	-34.98	-13.00	-21.98	V
3262.10	-32.68	12.78	11.57	-31.47	-13.00	-18.47	V
LTE Band 26 / 3MHz / QPSK / RB Size 1 Offset 0/ The Worst Test Results for Middle							
Frequency(MHz)	S G.Lev (dBm)	Ant(dBi)	Loss	PMea	Limit	Margin	Polarity
				(dBm)	(dBm)	(dBm)	
1637.77	-33.62	9.56	9.72	-33.78	-13.00	-20.78	H
2457.11	-34.67	10.50	10.86	-35.03	-13.00	-22.03	H
3275.83	-32.68	12.78	11.57	-31.47	-13.00	-18.47	H
1637.77	-35.98	9.56	9.72	-36.14	-13.00	-23.14	V
2457.11	-33.78	10.50	10.86	-34.14	-13.00	-21.14	V
3275.83	-32.38	12.78	11.57	-31.17	-13.00	-18.17	V
LTE Band 26 / 3MHz / QPSK / RB Size 1 Offset 0/ The Worst Test Results for Highest							
Frequency(MHz)	S G.Lev (dBm)	Ant(dBi)	Loss	PMea	Limit	Margin	Polarity
				(dBm)	(dBm)	(dBm)	
1644.78	-33.82	9.56	9.72	-33.98	-13.00	-20.98	H
2467.13	-34.50	10.50	10.86	-34.86	-13.00	-21.86	H
3290.08	-32.24	12.78	11.57	-31.03	-13.00	-18.03	H
1644.78	-35.80	9.56	9.72	-35.96	-13.00	-22.96	V
2467.13	-34.31	10.50	10.86	-34.67	-13.00	-21.67	V
3290.08	-32.97	12.78	11.57	-31.76	-13.00	-18.76	V



LTE Band 26 / 5MHz / QPSK / RB Size 1 Offset 0/ The Worst Test Results for Lowest							
Frequency(MHz)	S G.Lev (dBm)	Ant(dBi)	Loss	PMea	Limit	Margin	Polarity
				(dBm)	(dBm)	(dBm)	
1633.04	-34.20	9.56	9.72	-34.36	-13.00	-21.36	H
2448.73	-35.12	10.50	10.86	-35.48	-13.00	-22.48	H
3265.99	-32.40	12.78	11.57	-31.19	-13.00	-18.19	H
1633.04	-35.05	9.56	9.72	-35.21	-13.00	-22.21	V
2448.73	-34.65	10.50	10.86	-35.01	-13.00	-22.01	V
3265.99	-31.87	12.78	11.57	-30.66	-13.00	-17.66	V
LTE Band 26 / 5MHz / QPSK / RB Size 1 Offset 0/ The Worst Test Results for Middle							
Frequency(MHz)	S G.Lev (dBm)	Ant(dBi)	Loss	PMea	Limit	Margin	Polarity
				(dBm)	(dBm)	(dBm)	
1643.06	-34.06	9.56	9.72	-34.22	-13.00	-21.22	H
2463.85	-35.09	10.50	10.86	-35.45	-13.00	-22.45	H
3286.14	-33.01	12.78	11.57	-31.80	-13.00	-18.80	H
1643.06	-35.29	9.56	9.72	-35.45	-13.00	-22.45	V
2463.85	-34.32	10.50	10.86	-34.68	-13.00	-21.68	V
3286.14	-31.74	12.78	11.57	-30.53	-13.00	-17.53	V
LTE Band 26 / 5MHz / QPSK / RB Size 1 Offset 0/ The Worst Test Results for Highest							
Frequency(MHz)	S G.Lev (dBm)	Ant(dBi)	Loss	PMea	Limit	Margin	Polarity
				(dBm)	(dBm)	(dBm)	
1693.61	-33.57	9.56	9.72	-33.73	-13.00	-20.73	H
2539.12	-34.88	10.50	10.86	-35.24	-13.00	-22.24	H
3386.08	-32.25	12.78	11.57	-31.04	-13.00	-18.04	H
1693.61	-35.84	9.56	9.72	-36.00	-13.00	-23.00	V
2539.12	-35.12	10.50	10.86	-35.48	-13.00	-22.48	V
3386.08	-32.41	12.78	11.57	-31.20	-13.00	-18.20	V

LTE Band 26 / 10MHz / QPSK / RB Size 1 Offset 0/ The Worst Test Results for Middle							
Frequency(MHz)	S G.Lev (dBm)	Ant(dBi)	Loss	PMea	Limit	Margin	Polarity
				(dBm)	(dBm)	(dBm)	
1638.07	-34.11	9.56	9.72	-34.27	-13.00	-21.27	H
2457.23	-35.33	10.50	10.86	-35.69	-13.00	-22.69	H
3275.96	-32.69	12.78	11.57	-31.48	-13.00	-18.48	H
1638.07	-35.12	9.56	9.72	-35.28	-13.00	-22.28	V
2457.23	-34.67	10.50	10.86	-35.03	-13.00	-22.03	V
3275.96	-32.23	12.78	11.57	-31.02	-13.00	-18.02	V



LTE Band 41 / 5MHz / QPSK / RB Size 1 Offset 0/ The Worst Test Results for Lowest							
Frequency(MHz)	S G.Lev (dBm)	Ant(dBi)	Loss	PMea (dBm)	Limit (dBm)	Margin (dBm)	Polarity
4997.26	-33.73	12.66	15.86	-36.93	-25.00	-11.93	H
7495.79	-34.25	11.46	19.28	-42.07	-25.00	-17.07	H
9994.20	-32.24	12.79	23.19	-42.64	-25.00	-17.64	H
4997.26	-35.83	12.66	15.86	-39.03	-25.00	-14.03	V
7495.79	-35.16	11.46	19.28	-42.98	-25.00	-17.98	V
9994.20	-32.52	12.79	23.19	-42.92	-25.00	-17.92	V
LTE Band 41 / 5MHz / QPSK / RB Size 1 Offset 0/ The Worst Test Results for Middle							
Frequency(MHz)	S G.Lev (dBm)	Ant(dBi)	Loss	PMea (dBm)	Limit (dBm)	Margin (dBm)	Polarity
5186.14	-34.38	12.72	15.86	-37.52	-25.00	-12.52	H
7779.29	-35.44	11.46	19.28	-43.26	-25.00	-18.26	H
10372.26	-33.53	12.09	23.19	-44.63	-25.00	-19.63	H
5186.14	-35.61	12.72	15.86	-38.75	-25.00	-13.75	V
7779.29	-33.77	11.46	19.28	-41.59	-25.00	-16.59	V
10372.26	-32.40	12.09	23.19	-43.50	-25.00	-18.50	V
LTE Band 41 / 5MHz / QPSK / RB Size 1 Offset 0/ The Worst Test Results for Highest							
Frequency(MHz)	S G.Lev (dBm)	Ant(dBi)	Loss	PMea (dBm)	Limit (dBm)	Margin (dBm)	Polarity
5375.05	-33.75	12.76	15.86	-36.85	-25.00	-11.85	H
8062.70	-34.76	11.45	19.28	-42.59	-25.00	-17.59	H
10749.91	-32.46	12.28	23.19	-43.37	-25.00	-18.37	H
5375.05	-34.58	12.76	15.86	-37.68	-25.00	-12.68	V
8062.70	-34.18	11.45	19.28	-42.01	-25.00	-17.01	V
10749.91	-33.07	12.28	23.19	-43.98	-25.00	-18.98	V



LTE Band 41 / 10MHz / QPSK / RB Size 1 Offset 0/ The Worst Test Results for Lowest							
Frequency(MHz)	S G.Lev (dBm)	Ant(dBi)	Loss	PMea	Limit	Margin	Polarity
				(dBm)	(dBm)	(dBm)	
5002.15	-33.97	12.66	15.86	-37.17	-25.00	-12.17	H
7503.02	-34.61	11.46	19.28	-42.43	-25.00	-17.43	H
10004.13	-32.61	12.79	23.19	-43.01	-25.00	-18.01	H
5002.15	-35.86	12.66	15.86	-39.06	-25.00	-14.06	V
7503.02	-34.25	11.46	19.28	-42.07	-25.00	-17.07	V
10004.13	-32.58	12.79	23.19	-42.98	-25.00	-17.98	V
LTE Band 41 / 10MHz / QPSK / RB Size 1 Offset 0/ The Worst Test Results for Middle							
Frequency(MHz)	S G.Lev (dBm)	Ant(dBi)	Loss	PMea	Limit	Margin	Polarity
				(dBm)	(dBm)	(dBm)	
5185.95	-33.72	12.72	15.86	-36.86	-25.00	-11.86	H
7779.36	-34.73	11.46	19.28	-42.55	-25.00	-17.55	H
10371.87	-33.36	12.09	23.19	-44.46	-25.00	-19.46	H
5185.95	-35.49	12.72	15.86	-38.63	-25.00	-13.63	V
7779.36	-33.87	11.46	19.28	-41.69	-25.00	-16.69	V
10371.87	-32.46	12.09	23.19	-43.56	-25.00	-18.56	V
LTE Band 41 / 10MHz / QPSK / RB Size 1 Offset 0/ The Worst Test Results for Highest							
Frequency(MHz)	S G.Lev (dBm)	Ant(dBi)	Loss	PMea	Limit	Margin	Polarity
				(dBm)	(dBm)	(dBm)	
5370.00	-34.48	12.76	15.86	-37.58	-25.00	-12.58	H
8054.90	-35.44	11.45	19.28	-43.27	-25.00	-18.27	H
10739.75	-32.20	12.28	23.19	-43.11	-25.00	-18.11	H
5370.00	-34.61	12.76	15.86	-37.71	-25.00	-12.71	V
8054.90	-34.44	11.45	19.28	-42.27	-25.00	-17.27	V
10739.75	-32.94	12.28	23.19	-43.85	-25.00	-18.85	V



LTE Band 41 / 15MHz / QPSK / RB Size 1 Offset 0/ The Worst Test Results for Lowest							
Frequency(MHz)	S G.Lev (dBm)	Ant(dBi)	Loss	PMea (dBm)	Limit (dBm)	Margin (dBm)	Polarity
5007.01	-33.99	12.66	15.86	-37.19	-25.00	-12.19	H
7510.72	-34.16	11.46	19.28	-41.98	-25.00	-16.98	H
10014.37	-32.48	12.79	23.19	-42.88	-25.00	-17.88	H
5007.01	-35.66	12.66	15.86	-38.86	-25.00	-13.86	V
7510.72	-35.09	11.46	19.28	-42.91	-25.00	-17.91	V
10014.37	-33.05	12.79	23.19	-43.45	-25.00	-18.45	V
LTE Band 41 / 15MHz / QPSK / RB Size 1 Offset 0/ The Worst Test Results for Middle							
Frequency(MHz)	S G.Lev (dBm)	Ant(dBi)	Loss	PMea (dBm)	Limit (dBm)	Margin (dBm)	Polarity
5185.91	-33.96	12.72	15.86	-37.10	-25.00	-12.10	H
7779.03	-35.24	11.46	19.28	-43.06	-25.00	-18.06	H
10371.93	-33.33	12.09	23.19	-44.43	-25.00	-19.43	H
5185.91	-35.42	12.72	15.86	-38.56	-25.00	-13.56	V
7779.03	-33.76	11.46	19.28	-41.58	-25.00	-16.58	V
10371.93	-31.82	12.09	23.19	-42.92	-25.00	-17.92	V
LTE Band 41 / 15MHz / QPSK / RB Size 1 Offset 0/ The Worst Test Results for Highest							
Frequency(MHz)	S G.Lev (dBm)	Ant(dBi)	Loss	PMea (dBm)	Limit (dBm)	Margin (dBm)	Polarity
5365.16	-33.60	12.76	15.86	-36.70	-25.00	-11.70	H
8047.42	-34.94	11.45	19.28	-42.77	-25.00	-17.77	H
10730.02	-32.55	12.28	23.19	-43.46	-25.00	-18.46	H
5365.16	-34.63	12.76	15.86	-37.73	-25.00	-12.73	V
8047.42	-35.22	11.45	19.28	-43.05	-25.00	-18.05	V
10730.02	-33.01	12.28	23.19	-43.92	-25.00	-18.92	V



LTE Band 41 / 20MHz / QPSK / RB Size 1 Offset 0/ The Worst Test Results for Lowest							
Frequency(MHz)	S G.Lev (dBm)	Ant(dBi)	Loss	PMea	Limit	Margin	Polarity
				(dBm)	(dBm)	(dBm)	
5011.97	-34.88	12.66	15.86	-38.08	-25.00	-13.08	H
7517.94	-34.65	11.46	19.28	-42.47	-25.00	-17.47	H
10023.88	-32.35	12.79	23.19	-42.75	-25.00	-17.75	H
5011.97	-34.82	12.66	15.86	-38.02	-25.00	-13.02	V
7517.94	-34.62	11.46	19.28	-42.44	-25.00	-17.44	V
10023.88	-31.92	12.79	23.19	-42.32	-25.00	-17.32	V
LTE Band 41 / 20MHz / QPSK / RB Size 1 Offset 0/ The Worst Test Results for Middle							
Frequency(MHz)	S G.Lev (dBm)	Ant(dBi)	Loss	PMea	Limit	Margin	Polarity
				(dBm)	(dBm)	(dBm)	
5186.08	-33.81	12.72	15.86	-36.95	-25.00	-11.95	H
7779.36	-34.17	11.46	19.28	-41.99	-25.00	-16.99	H
10372.29	-33.15	12.09	23.19	-44.25	-25.00	-19.25	H
5186.08	-34.71	12.72	15.86	-37.85	-25.00	-12.85	V
7779.36	-34.22	11.46	19.28	-42.04	-25.00	-17.04	V
10372.29	-32.72	12.09	23.19	-43.82	-25.00	-18.82	V
LTE Band 41 / 20MHz / QPSK / RB Size 1 Offset 0/ The Worst Test Results for Highest							
Frequency(MHz)	S G.Lev (dBm)	Ant(dBi)	Loss	PMea	Limit	Margin	Polarity
				(dBm)	(dBm)	(dBm)	
5359.83	-34.93	12.76	15.86	-38.03	-25.00	-13.03	H
8039.90	-34.90	11.45	19.28	-42.73	-25.00	-17.73	H
10720.20	-33.50	12.28	23.19	-44.41	-25.00	-19.41	H
5359.83	-35.17	12.76	15.86	-38.27	-25.00	-13.27	V
8039.90	-34.24	11.45	19.28	-42.07	-25.00	-17.07	V
10720.20	-32.10	12.28	23.19	-43.01	-25.00	-18.01	V



LTE Band 66 / 1.4MHz / QPSK / RB Size 1 Offset 0/ The Worst Test Results for Lowest							
Frequency(MHz)	S G.Lev (dBm)	Ant(dBi)	Loss	PMea	Limit	Margin	Polarity
				(dBm)	(dBm)	(dBm)	
3421.37	-34.20	12.90	12.56	-33.86	-13.00	-20.86	H
5131.86	-35.06	13.10	16.32	-38.28	-13.00	-25.28	H
6842.68	-32.43	12.33	21.13	-41.23	-13.00	-28.23	H
3421.37	-35.83	12.90	12.56	-35.49	-13.00	-22.49	V
5131.86	-34.40	13.10	16.32	-37.62	-13.00	-24.62	V
6842.68	-33.09	12.33	21.13	-41.89	-13.00	-28.89	V
LTE Band 66 / 1.4MHz / QPSK / RB Size 1 Offset 0/ The Worst Test Results for Middle							
Frequency(MHz)	S G.Lev (dBm)	Ant(dBi)	Loss	PMea	Limit	Margin	Polarity
				(dBm)	(dBm)	(dBm)	
3490.21	-33.97	12.90	12.56	-33.63	-13.00	-20.63	H
5235.26	-34.14	13.10	16.32	-37.36	-13.00	-24.36	H
6980.15	-32.92	12.33	21.13	-41.72	-13.00	-28.72	H
3490.21	-35.73	12.90	12.56	-35.39	-13.00	-22.39	V
5235.26	-34.34	13.10	16.32	-37.56	-13.00	-24.56	V
6980.15	-32.08	12.33	21.13	-40.88	-13.00	-27.88	V
LTE Band 66 / 1.4MHz / QPSK / RB Size 1 Offset 0/ The Worst Test Results for Highest							
Frequency(MHz)	S G.Lev (dBm)	Ant(dBi)	Loss	PMea	Limit	Margin	Polarity
				(dBm)	(dBm)	(dBm)	
3557.75	-34.87	12.90	12.56	-34.53	-13.00	-21.53	H
5337.06	-34.71	13.10	16.32	-37.93	-13.00	-24.93	H
7116.74	-32.66	12.33	21.13	-41.46	-13.00	-28.46	H
3557.75	-35.53	12.90	12.56	-35.19	-13.00	-22.19	V
5337.06	-35.18	13.10	16.32	-38.40	-13.00	-25.40	V
7116.74	-33.12	12.33	21.13	-41.92	-13.00	-28.92	V



LTE Band 66 / 3MHz / QPSK / RB Size 1 Offset 0/ The Worst Test Results for Lowest							
Frequency(MHz)	S G.Lev (dBm)	Ant(dBi)	Loss	PMea	Limit	Margin	Polarity
				(dBm)	(dBm)	(dBm)	
3423.13	-33.47	12.90	12.56	-33.13	-13.00	-20.13	H
5134.21	-34.43	13.10	16.32	-37.65	-13.00	-24.65	H
6845.78	-32.72	12.33	21.13	-41.52	-13.00	-28.52	H
3423.13	-35.72	12.90	12.56	-35.38	-13.00	-22.38	V
5134.21	-34.72	13.10	16.32	-37.94	-13.00	-24.94	V
6845.78	-32.77	12.33	21.13	-41.57	-13.00	-28.57	V
LTE Band 66 / 3MHz / QPSK / RB Size 1 Offset 0/ The Worst Test Results for Middle							
Frequency(MHz)	S G.Lev (dBm)	Ant(dBi)	Loss	PMea	Limit	Margin	Polarity
				(dBm)	(dBm)	(dBm)	
3489.88	-34.30	12.90	12.56	-33.96	-13.00	-20.96	H
5235.01	-34.41	13.10	16.32	-37.63	-13.00	-24.63	H
6980.21	-33.43	12.33	21.13	-42.23	-13.00	-29.23	H
3489.88	-34.96	12.90	12.56	-34.62	-13.00	-21.62	V
5235.01	-33.97	13.10	16.32	-37.19	-13.00	-24.19	V
6980.21	-31.82	12.33	21.13	-40.62	-13.00	-27.62	V
LTE Band 66 / 3MHz / QPSK / RB Size 1 Offset 0/ The Worst Test Results for Highest							
Frequency(MHz)	S G.Lev (dBm)	Ant(dBi)	Loss	PMea	Limit	Margin	Polarity
				(dBm)	(dBm)	(dBm)	
3556.98	-34.26	12.90	12.56	-33.92	-13.00	-20.92	H
5262.44	-34.60	13.10	16.32	-37.82	-13.00	-24.82	H
7113.96	-32.94	12.33	21.13	-41.74	-13.00	-28.74	H
3556.98	-35.95	12.90	12.56	-35.61	-13.00	-22.61	V
5262.44	-35.06	13.10	16.32	-38.28	-13.00	-25.28	V
7113.96	-32.82	12.33	21.13	-41.62	-13.00	-28.62	V



LTE Band 66 / 5MHz / QPSK / RB Size 1 Offset 0/ The Worst Test Results for Lowest							
Frequency(MHz)	S G.Lev (dBm)	Ant(dBi)	Loss	PMea (dBm)	Limit (dBm)	Margin (dBm)	Polarity
3425.46	-34.79	12.90	12.56	-34.45	-13.00	-21.45	H
5137.56	-35.22	13.10	16.32	-38.44	-13.00	-25.44	H
6850.19	-33.64	12.33	21.13	-42.44	-13.00	-29.44	H
3425.46	-35.45	12.90	12.56	-35.11	-13.00	-22.11	V
5137.56	-35.16	13.10	16.32	-38.38	-13.00	-25.38	V
6850.19	-32.35	12.33	21.13	-41.15	-13.00	-28.15	V
LTE Band 66 / 5MHz / QPSK / RB Size 1 Offset 0/ The Worst Test Results for Middle							
Frequency(MHz)	S G.Lev (dBm)	Ant(dBi)	Loss	PMea (dBm)	Limit (dBm)	Margin (dBm)	Polarity
3489.89	-34.94	12.90	12.56	-34.60	-13.00	-21.60	H
5234.98	-34.48	13.10	16.32	-37.70	-13.00	-24.70	H
6979.95	-32.27	12.33	21.13	-41.07	-13.00	-28.07	H
3489.89	-35.06	12.90	12.56	-34.72	-13.00	-21.72	V
5234.98	-34.14	13.10	16.32	-37.36	-13.00	-24.36	V
6979.95	-32.63	12.33	21.13	-41.43	-13.00	-28.43	V
LTE Band 66 / 5MHz / QPSK / RB Size 1 Offset 0/ The Worst Test Results for Highest							
Frequency(MHz)	S G.Lev (dBm)	Ant(dBi)	Loss	PMea (dBm)	Limit (dBm)	Margin (dBm)	Polarity
3558.03	-33.74	12.90	12.56	-33.40	-13.00	-20.40	H
5235.10	-35.17	13.10	16.32	-38.39	-13.00	-25.39	H
7110.21	-32.44	12.33	21.13	-41.24	-13.00	-28.24	H
3558.03	-35.36	12.90	12.56	-35.02	-13.00	-22.02	V
5235.10	-34.60	13.10	16.32	-37.82	-13.00	-24.82	V
7110.21	-32.10	12.33	21.13	-40.90	-13.00	-27.90	V



LTE Band 66 / 10MHz / QPSK / RB Size 1 Offset 0/ The Worst Test Results for Lowest							
Frequency(MHz)	S G.Lev (dBm)	Ant(dBi)	Loss	PMea	Limit	Margin	Polarity
				(dBm)	(dBm)	(dBm)	
3430.28	-33.60	12.90	12.56	-33.26	-13.00	-20.26	H
5145.12	-34.42	13.10	16.32	-37.64	-13.00	-24.64	H
6879.95	-33.18	12.33	21.13	-41.98	-13.00	-28.98	H
3430.28	-34.77	12.90	12.56	-34.43	-13.00	-21.43	V
5145.12	-34.55	13.10	16.32	-37.77	-13.00	-24.77	V
6879.95	-32.88	12.33	21.13	-41.68	-13.00	-28.68	V
LTE Band 66 / 10MHz / QPSK / RB Size 1 Offset 0/ The Worst Test Results for Middle							
Frequency(MHz)	S G.Lev (dBm)	Ant(dBi)	Loss	PMea	Limit	Margin	Polarity
				(dBm)	(dBm)	(dBm)	
3489.94	-33.70	12.90	12.56	-33.36	-13.00	-20.36	H
5235.04	-34.03	13.10	16.32	-37.25	-13.00	-24.25	H
6979.93	-33.25	12.33	21.13	-42.05	-13.00	-29.05	H
3489.94	-35.56	12.90	12.56	-35.22	-13.00	-22.22	V
5235.04	-33.77	13.10	16.32	-36.99	-13.00	-23.99	V
6979.93	-32.95	12.33	21.13	-41.75	-13.00	-28.75	V
LTE Band 66 / 10MHz / QPSK / RB Size 1 Offset 0/ The Worst Test Results for Highest							
Frequency(MHz)	S G.Lev (dBm)	Ant(dBi)	Loss	PMea	Limit	Margin	Polarity
				(dBm)	(dBm)	(dBm)	
3550.41	-33.57	12.90	12.56	-33.23	-13.00	-20.23	H
5235.50	-35.25	13.10	16.32	-38.47	-13.00	-25.47	H
7100.24	-32.98	12.33	21.13	-41.78	-13.00	-28.78	H
3550.41	-35.50	12.90	12.56	-35.16	-13.00	-22.16	V
5235.50	-34.94	13.10	16.32	-38.16	-13.00	-25.16	V
7100.24	-31.78	12.33	21.13	-40.58	-13.00	-27.58	V



LTE Band 66 / 15MHz / QPSK / RB Size 1 Offset 0/ The Worst Test Results for Lowest							
Frequency(MHz)	S G.Lev (dBm)	Ant(dBi)	Loss	PMea (dBm)	Limit (dBm)	Margin (dBm)	Polarity
3435.00	-34.77	12.90	12.56	-34.43	-13.00	-21.43	H
5152.48	-34.05	13.10	16.32	-37.27	-13.00	-24.27	H
6870.20	-33.35	12.33	21.13	-42.15	-13.00	-29.15	H
3435.00	-35.02	12.90	12.56	-34.68	-13.00	-21.68	V
5152.48	-35.02	13.10	16.32	-38.24	-13.00	-25.24	V
6870.20	-32.74	12.33	21.13	-41.54	-13.00	-28.54	V
LTE Band 66 / 15MHz / QPSK / RB Size 1 Offset 0/ The Worst Test Results for Middle							
Frequency(MHz)	S G.Lev (dBm)	Ant(dBi)	Loss	PMea (dBm)	Limit (dBm)	Margin (dBm)	Polarity
3490.14	-33.66	12.90	12.56	-33.32	-13.00	-20.32	H
5235.17	-34.04	13.10	16.32	-37.26	-13.00	-24.26	H
6980.09	-33.12	12.33	21.13	-41.92	-13.00	-28.92	H
3490.14	-35.74	12.90	12.56	-35.40	-13.00	-22.40	V
5235.17	-34.49	13.10	16.32	-37.71	-13.00	-24.71	V
6980.09	-32.03	12.33	21.13	-40.83	-13.00	-27.83	V
LTE Band 66 / 15MHz / QPSK / RB Size 1 Offset 0/ The Worst Test Results for Highest							
Frequency(MHz)	S G.Lev (dBm)	Ant(dBi)	Loss	PMea (dBm)	Limit (dBm)	Margin (dBm)	Polarity
3544.77	-33.96	12.90	12.56	-33.62	-13.00	-20.62	H
5332.59	-35.21	13.10	16.32	-38.43	-13.00	-25.43	H
7089.93	-33.53	12.33	21.13	-42.33	-13.00	-29.33	H
3544.77	-34.71	12.90	12.56	-34.37	-13.00	-21.37	V
5332.59	-34.84	13.10	16.32	-38.06	-13.00	-25.06	V
7089.93	-32.01	12.33	21.13	-40.81	-13.00	-27.81	V



LTE Band 66 / 20MHz / QPSK / RB Size 1 Offset 0/ The Worst Test Results for Lowest							
Frequency(MHz)	S G.Lev (dBm)	Ant(dBi)	Loss	PMea	Limit	Margin	Polarity
				(dBm)	(dBm)	(dBm)	
3440.22	-33.69	12.90	12.56	-33.35	-13.00	-20.35	H
5159.93	-34.35	13.10	16.32	-37.57	-13.00	-24.57	H
6880.08	-33.55	12.33	21.13	-42.35	-13.00	-29.35	H
3440.22	-34.78	12.90	12.56	-34.44	-13.00	-21.44	V
5159.93	-35.10	13.10	16.32	-38.32	-13.00	-25.32	V
6880.08	-32.11	12.33	21.13	-40.91	-13.00	-27.91	V
LTE Band 66 / 20MHz / QPSK / RB Size 1 Offset 0/ The Worst Test Results for Middle							
Frequency(MHz)	S G.Lev (dBm)	Ant(dBi)	Loss	PMea	Limit	Margin	Polarity
				(dBm)	(dBm)	(dBm)	
3489.99	-34.05	12.90	12.56	-33.71	-13.00	-20.71	H
5235.14	-35.03	13.10	16.32	-38.25	-13.00	-25.25	H
6980.04	-33.21	12.33	21.13	-42.01	-13.00	-29.01	H
3489.99	-35.29	12.90	12.56	-34.95	-13.00	-21.95	V
5235.14	-34.04	13.10	16.32	-37.26	-13.00	-24.26	V
6980.04	-32.57	12.33	21.13	-41.37	-13.00	-28.37	V
LTE Band 66 / 20MHz / QPSK / RB Size 1 Offset 0/ The Worst Test Results for Highest							
Frequency(MHz)	S G.Lev (dBm)	Ant(dBi)	Loss	PMea	Limit	Margin	Polarity
				(dBm)	(dBm)	(dBm)	
3539.89	-33.93	12.90	12.56	-33.59	-13.00	-20.59	H
5310.18	-35.15	13.10	16.32	-38.37	-13.00	-25.37	H
7080.57	-33.60	12.33	21.13	-42.40	-13.00	-29.40	H
3539.89	-34.78	12.90	12.56	-34.44	-13.00	-21.44	V
5310.18	-35.17	13.10	16.32	-38.39	-13.00	-25.39	V
7080.57	-32.32	12.33	21.13	-41.12	-13.00	-28.12	V



LTE Band 71 / 5MHz / QPSK / RB Size 1 Offset 0/ The Worst Test Results for Lowest							
Frequency(MHz)	S G.Lev (dBm)	Ant(dBi)	Loss	PMea	Limit	Margin	Polarity
				(dBm)	(dBm)	(dBm)	
1330.71	-34.81	8.17	9.34	-35.98	-13.00	-22.98	H
1966.39	-34.07	9.53	10.42	-34.96	-13.00	-21.96	H
2661.61	-32.21	11.27	11.12	-32.06	-13.00	-19.06	H
1330.71	-35.54	8.17	9.34	-36.71	-13.00	-23.71	V
1966.39	-34.93	9.53	10.42	-35.82	-13.00	-22.82	V
2661.61	-33.14	11.27	11.12	-32.99	-13.00	-19.99	V
LTE Band 71 / 5MHz / QPSK / RB Size 1 Offset 0/ The Worst Test Results for Middle							
Frequency(MHz)	S G.Lev (dBm)	Ant(dBi)	Loss	PMea	Limit	Margin	Polarity
				(dBm)	(dBm)	(dBm)	
1360.98	-34.02	8.17	9.34	-35.19	-13.00	-22.19	H
2041.44	-34.30	9.53	10.42	-35.19	-13.00	-22.19	H
2721.78	-32.66	11.27	11.12	-32.51	-13.00	-19.51	H
1360.98	-35.37	8.17	9.34	-36.54	-13.00	-23.54	V
2041.44	-34.10	9.53	10.42	-34.99	-13.00	-21.99	V
2721.78	-32.06	11.27	11.12	-31.91	-13.00	-18.91	V
LTE Band 71 / 5MHz / QPSK / RB Size 1 Offset 0/ The Worst Test Results for Highest							
Frequency(MHz)	S G.Lev (dBm)	Ant(dBi)	Loss	PMea	Limit	Margin	Polarity
				(dBm)	(dBm)	(dBm)	
1390.81	-34.39	8.17	9.34	-35.56	-13.00	-22.56	H
2086.12	-35.35	9.53	10.42	-36.24	-13.00	-23.24	H
2782.17	-32.16	11.27	11.12	-32.01	-13.00	-19.01	H
1390.81	-35.91	8.17	9.34	-37.08	-13.00	-24.08	V
2086.12	-34.00	9.53	10.42	-34.89	-13.00	-21.89	V
2782.17	-32.77	11.27	11.12	-32.62	-13.00	-19.62	V



LTE Band 71 / 10MHz / QPSK / RB Size 1 Offset 0/ The Worst Test Results for Lowest							
Frequency(MHz)	S G.Lev (dBm)	Ant(dBi)	Loss	PMea	Limit	Margin	Polarity
				(dBm)	(dBm)	(dBm)	
1336.08	-34.59	8.17	9.34	-35.76	-13.00	-22.76	H
2004.00	-34.62	9.53	10.42	-35.51	-13.00	-22.51	H
2671.90	-33.02	11.27	11.12	-32.87	-13.00	-19.87	H
1336.08	-36.00	8.17	9.34	-37.17	-13.00	-24.17	V
2004.00	-34.89	9.53	10.42	-35.78	-13.00	-22.78	V
2671.90	-32.52	11.27	11.12	-32.37	-13.00	-19.37	V
LTE Band 71 / 10MHz / QPSK / RB Size 1 Offset 0/ The Worst Test Results for Middle							
Frequency(MHz)	S G.Lev (dBm)	Ant(dBi)	Loss	PMea	Limit	Margin	Polarity
				(dBm)	(dBm)	(dBm)	
1361.01	-34.41	8.17	9.34	-35.58	-13.00	-22.58	H
2041.42	-35.43	9.53	10.42	-36.32	-13.00	-23.32	H
2721.98	-33.37	11.27	11.12	-33.22	-13.00	-20.22	H
1361.01	-35.37	8.17	9.34	-36.54	-13.00	-23.54	V
2041.42	-34.51	9.53	10.42	-35.40	-13.00	-22.40	V
2721.98	-32.31	11.27	11.12	-32.16	-13.00	-19.16	V
LTE Band 71 / 10MHz / QPSK / RB Size 1 Offset 0/ The Worst Test Results for Highest							
Frequency(MHz)	S G.Lev (dBm)	Ant(dBi)	Loss	PMea	Limit	Margin	Polarity
				(dBm)	(dBm)	(dBm)	
1386.20	-33.57	8.17	9.34	-34.74	-13.00	-21.74	H
2079.08	-35.31	9.53	10.42	-36.20	-13.00	-23.20	H
2721.86	-33.22	11.27	11.12	-33.07	-13.00	-20.07	H
1386.20	-34.91	8.17	9.34	-36.08	-13.00	-23.08	V
2079.08	-34.42	9.53	10.42	-35.31	-13.00	-22.31	V
2721.86	-32.48	11.27	11.12	-32.33	-13.00	-19.33	V



LTE Band 71 / 15MHz / QPSK / RB Size 1 Offset 0/ The Worst Test Results for Lowest							
Frequency(MHz)	S G.Lev (dBm)	Ant(dBi)	Loss	PMea	Limit	Margin	Polarity
				(dBm)	(dBm)	(dBm)	
1341.16	-34.55	8.17	9.34	-35.72	-13.00	-22.72	H
2010.74	-35.34	9.53	10.42	-36.23	-13.00	-23.23	H
2682.07	-32.56	11.27	11.12	-32.41	-13.00	-19.41	H
1341.16	-35.60	8.17	9.34	-36.77	-13.00	-23.77	V
2010.74	-33.94	9.53	10.42	-34.83	-13.00	-21.83	V
2682.07	-33.15	11.27	11.12	-33.00	-13.00	-20.00	V
LTE Band 71 / 15MHz / QPSK / RB Size 1 Offset 0/ The Worst Test Results for Middle							
Frequency(MHz)	S G.Lev (dBm)	Ant(dBi)	Loss	PMea	Limit	Margin	Polarity
				(dBm)	(dBm)	(dBm)	
1361.30	-34.43	8.17	9.34	-35.60	-13.00	-22.60	H
2041.29	-34.55	9.53	10.42	-35.44	-13.00	-22.44	H
2722.03	-32.52	11.27	11.12	-32.37	-13.00	-19.37	H
1361.30	-35.39	8.17	9.34	-36.56	-13.00	-23.56	V
2041.29	-35.02	9.53	10.42	-35.91	-13.00	-22.91	V
2722.03	-32.35	11.27	11.12	-32.20	-13.00	-19.20	V
LTE Band 71 / 15MHz / QPSK / RB Size 1 Offset 0/ The Worst Test Results for Highest							
Frequency(MHz)	S G.Lev (dBm)	Ant(dBi)	Loss	PMea	Limit	Margin	Polarity
				(dBm)	(dBm)	(dBm)	
1380.71	-33.56	8.17	9.34	-34.73	-13.00	-21.73	H
2070.78	-34.43	9.53	10.42	-35.32	-13.00	-22.32	H
2761.90	-33.54	11.27	11.12	-33.39	-13.00	-20.39	H
1380.71	-35.70	8.17	9.34	-36.87	-13.00	-23.87	V
2070.78	-34.60	9.53	10.42	-35.49	-13.00	-22.49	V
2761.90	-32.17	11.27	11.12	-32.02	-13.00	-19.02	V



LTE Band 71 / 20MHz / QPSK / RB Size 1 Offset 0/ The Worst Test Results for Lowest							
Frequency(MHz)	S G.Lev (dBm)	Ant(dBi)	Loss	PMea	Limit	Margin	Polarity
				(dBm)	(dBm)	(dBm)	
1345.84	-33.48	8.17	9.34	-34.65	-13.00	-21.65	H
2019.07	-34.93	9.53	10.42	-35.82	-13.00	-22.82	H
2691.80	-33.32	11.27	11.12	-33.17	-13.00	-20.17	H
1345.84	-35.13	8.17	9.34	-36.30	-13.00	-23.30	V
2019.07	-35.19	9.53	10.42	-36.08	-13.00	-23.08	V
2691.80	-32.01	11.27	11.12	-31.86	-13.00	-18.86	V
LTE Band 71 / 20MHz / QPSK / RB Size 1 Offset 0/ The Worst Test Results for Middle							
Frequency(MHz)	S G.Lev (dBm)	Ant(dBi)	Loss	PMea	Limit	Margin	Polarity
				(dBm)	(dBm)	(dBm)	
1361.01	-34.41	8.17	9.34	-35.58	-13.00	-22.58	H
2041.44	-34.96	9.53	10.42	-35.85	-13.00	-22.85	H
2721.86	-32.81	11.27	11.12	-32.66	-13.00	-19.66	H
1361.01	-35.85	8.17	9.34	-37.02	-13.00	-24.02	V
2041.44	-34.16	9.53	10.42	-35.05	-13.00	-22.05	V
2721.86	-32.10	11.27	11.12	-31.95	-13.00	-18.95	V
LTE Band 71 / 20MHz / QPSK / RB Size 1 Offset 0/ The Worst Test Results for Highest							
Frequency(MHz)	S G.Lev (dBm)	Ant(dBi)	Loss	PMea	Limit	Margin	Polarity
				(dBm)	(dBm)	(dBm)	
1375.84	-34.27	8.17	9.34	-35.44	-13.00	-22.44	H
2063.88	-34.59	9.53	10.42	-35.48	-13.00	-22.48	H
2751.94	-32.58	11.27	11.12	-32.43	-13.00	-19.43	H
1375.84	-35.99	8.17	9.34	-37.16	-13.00	-24.16	V
2063.88	-35.13	9.53	10.42	-36.02	-13.00	-23.02	V
2751.94	-31.84	11.27	11.12	-31.69	-13.00	-18.69	V



APPENDIX-PHOTOS OF TEST SETUP

Note: See test photos in setup photo document for the actual connections between Product and support equipment.

*****END OF THE REPORT*****