

Application note

2.4/5 GHz Dualband WiFi ANTENNA

*10 x 3.2 x 1.5 mm Ceramic Chip Antenna
(Ground Cleared Under Antenna 11.60mm x 6.25 mm)*

Pulse Part Number: W3006

Status

Author	PJN	Version	1.0.4
Checked by	KiKo	Date	2010.01.29
Approved by	KiKo	Date	2010.01.29

Table of Content

General Features and Applications	3
Antenna dimensions.....	4
Terminal configuration	5
Test setup for electrical measurements.....	8
Electrical performance test results	9
Packing	12
Mechanical Outline	15
Contact information	16

2.4/5 GHz Dualband WiFi Ceramic Chip Antenna

Ground cleared under antenna, clearance area **11.60 mm x 6.25 mm**

Features

- Low profile
- Compact size W x L x H (10 x 3.2 x 1.5 mm)
- Low weight (240 mg)
- Lead free materials
- Fully SMD compatible
- Lead free soldering compatible
- Tape and reel packing
- RoHS Compliant Product

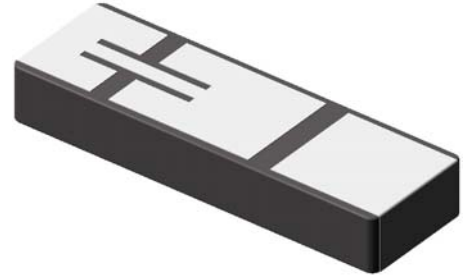

Applications

- **ZigBee IEEE 802.15.4**
- **IEEE 802.11a/b/g**
- **5 GHz WLAN**
- **2.4 GHz WLAN**
- **2.4 GHz ISM Band Systems**

Electrical specifications @ +25 °C

Note: Electrical characteristics depend on test board (GP) size and antenna positioning on GP and Ground Clearance area size.

Dualband WLAN

*Typical performance (testboard size 80 x 37 mm, PWB ground clearance area **11.60 x 6.25 mm**)*

1.5nH shunt inductor used for impedance matching.

Frequency Range [MHz]	Max Gain [dBi]	Efficiency [%] / [dB]	Return loss min. [dB]	Impedance [Ω]	Operating Temperature [$^{\circ}$ C]
2400 – 2483.5	3,2 (peak) 2,7 (band edges)	70 / -1,55 (peak) 65 / -1,85 (band edges)	-8	50	-40 to +85
5150 – 5850	4,2 (peak) 3,0 (band edges)	80 / -0,95 (peak) 70 / -1,55 (band edges)	-10	50	-40 to +85

Pulse Finland Oy

Takatie 6
90440 Kempele, Finland
Tel: +358 207 935 500
Fax: +358 207 935 501

Domicile: Kempele
Business ID: 1933992-8
firstnamelastname@pulseeng.com
www.pulseeng.com/antennas



© 2006. All Rights Reserved.

2.4/5 GHz Dualband WiFi Ceramic Chip Antenna

Ground cleared under antenna, clearance area **11.60 mm x 6.25 mm**

Antenna dimensions

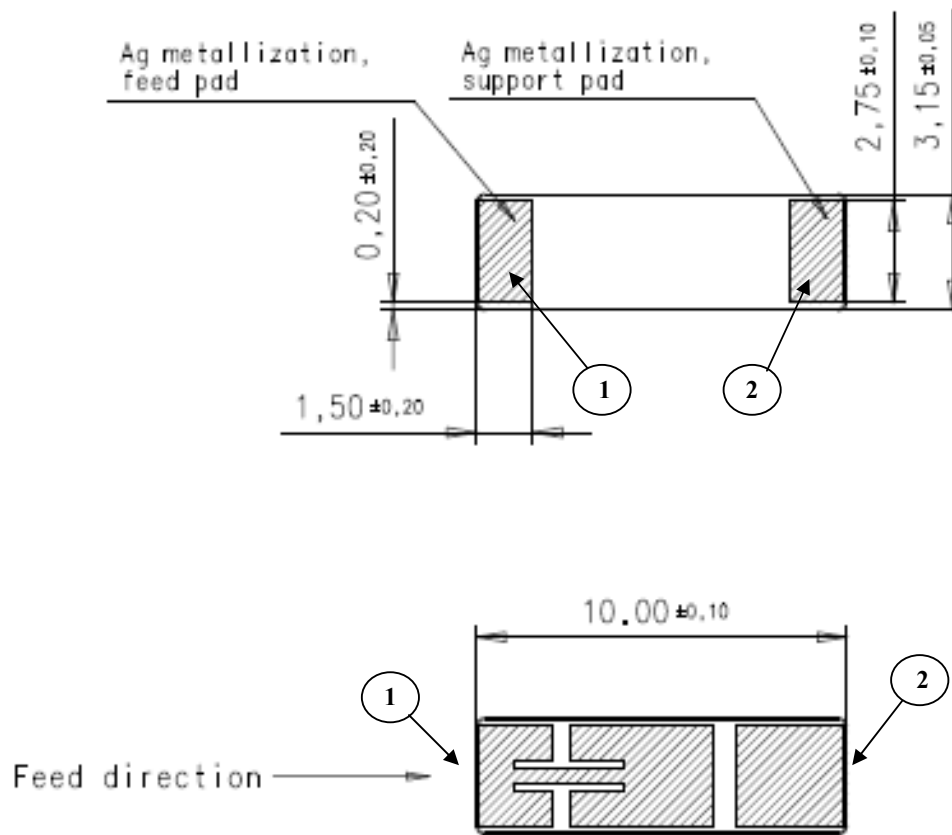

No.	Terminal Name	Terminal Dimensions
1	Feed	1.5 x 2.75 mm
2	Support pad	1.5 x 2.75 mm
Antenna feed pad can be identified by looking top surface metallization pattern		

2.4/5 GHz Dualband WiFi Ceramic Chip Antenna

Ground cleared under antenna, clearance area **11.60 mm x 6.25 mm**

Terminal Configuration

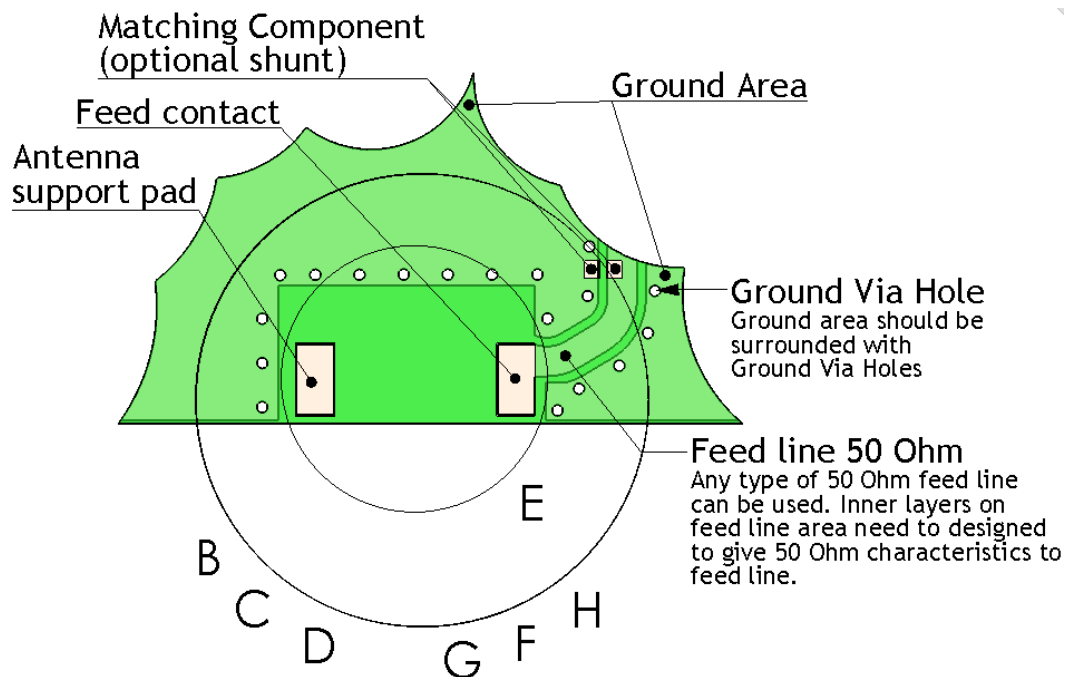

PWB manufacturing requirements according to IPC-A-600 revision G or similar

Shunt matching inductor, 1.5nH with presented setup.
Exact inductor value depends on specific application.

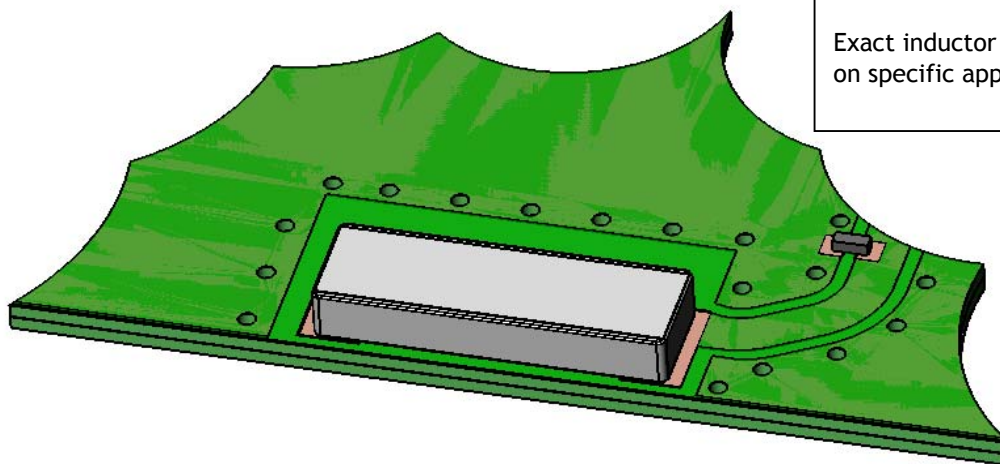

Ground Cleared Under Antenna. Ground removal area under antenna 11.6mm x 6.25mm.

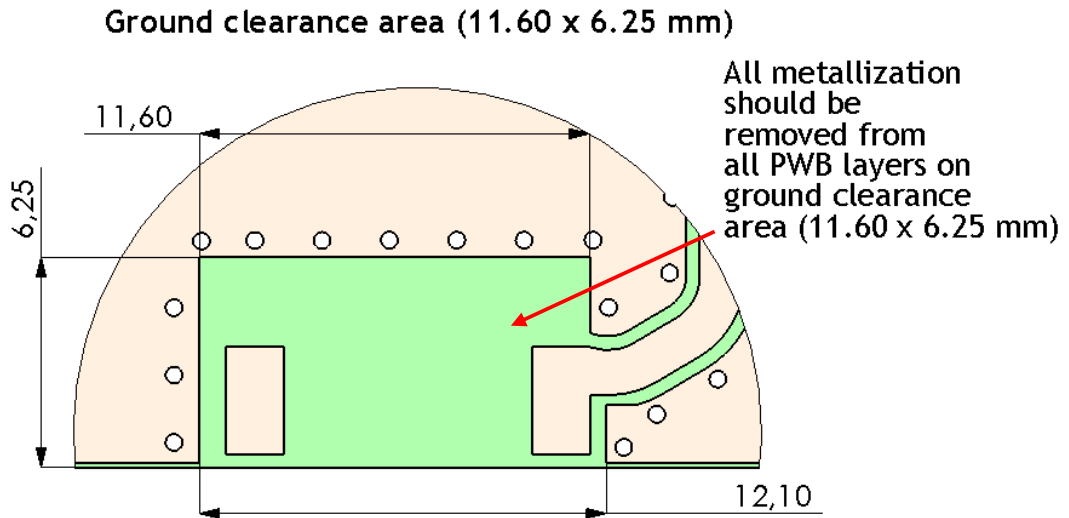

Opening in bottom/inner ground layers

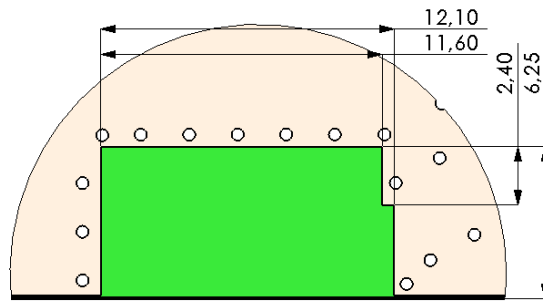

Opening in other layers (no ground/ RF)

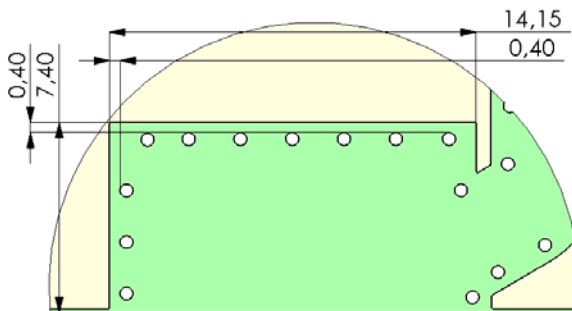

Recommended Antenna Pad Dimensions on PWB Layout (top surface)

Pad dimensions in top copper

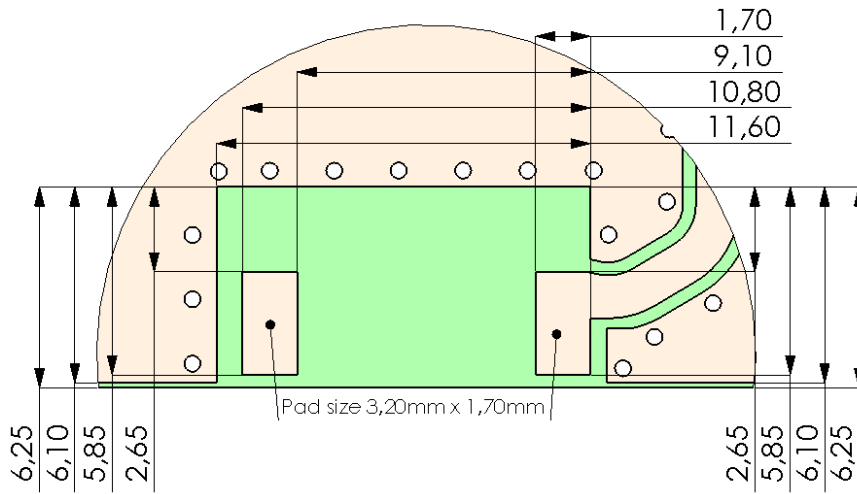

Recommended test board layout for electrical characteristic measurement, test board outline size 80 x 37mm

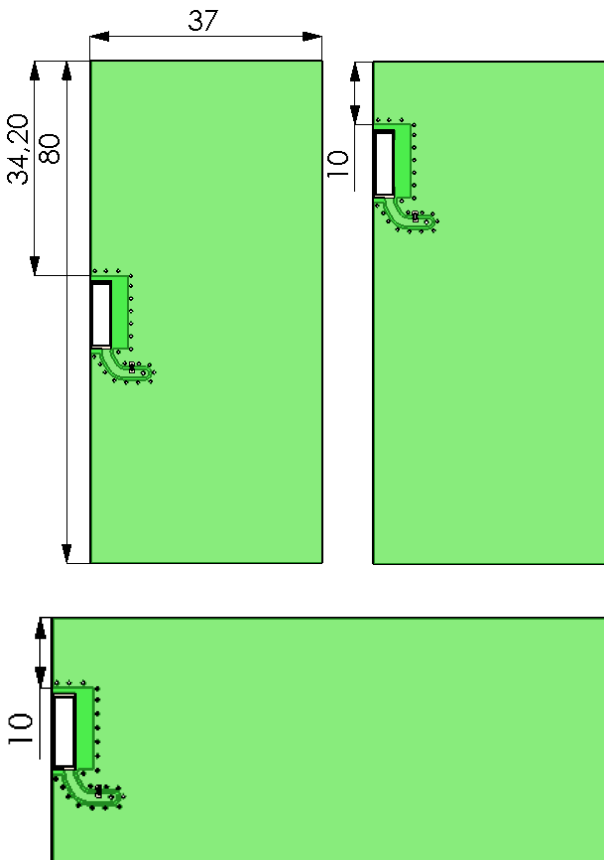

2.4/5 GHz Dualband WiFi Ceramic Chip Antenna

Ground cleared under antenna, clearance area **11.60 mm x 6.25 mm**

2.4 GHz Typical Electrical Characteristics (T=25 °C)

Measured on the 80x37mm test board with matching circuit, 1.5nH shunt inductor

Typical Return Loss S11/ impedance

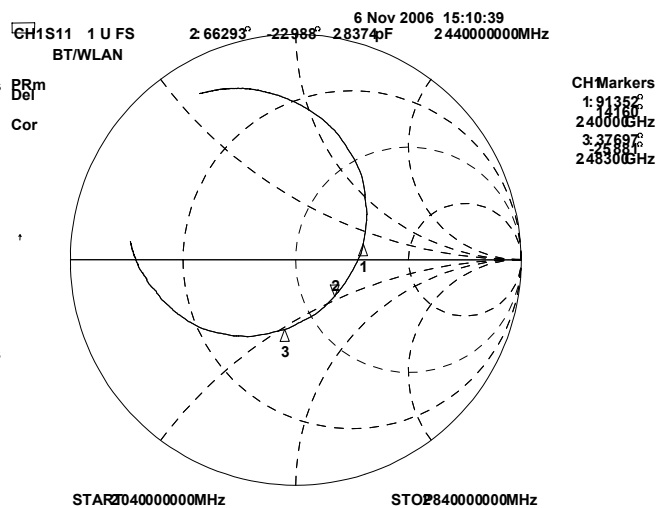
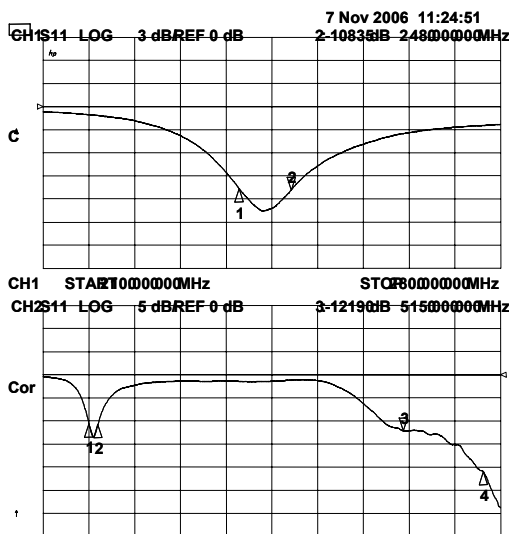

Free space efficiency and maximum gain

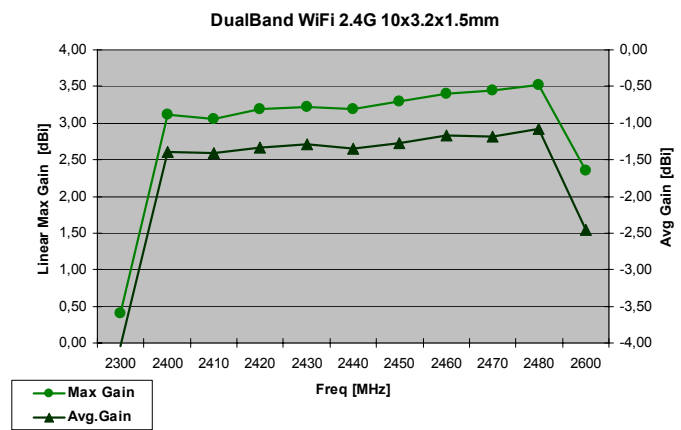
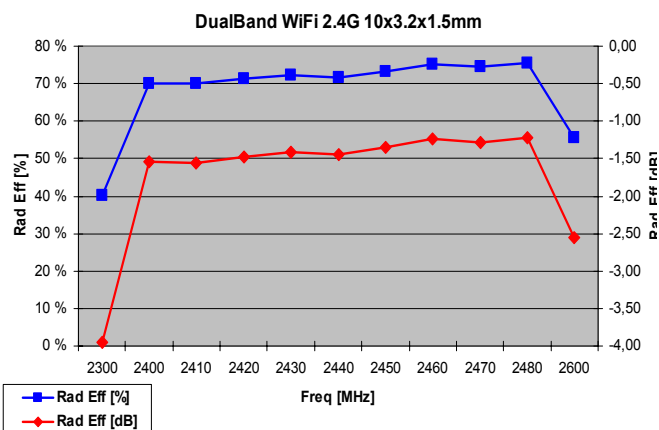

2.4/5 GHz Dualband WiFi Ceramic Chip Antenna

Ground cleared under antenna, clearance area **11.60 mm x 6.25 mm**

2.4 GHz Typical Free Space Radiation Patterns

XZ-PLANE

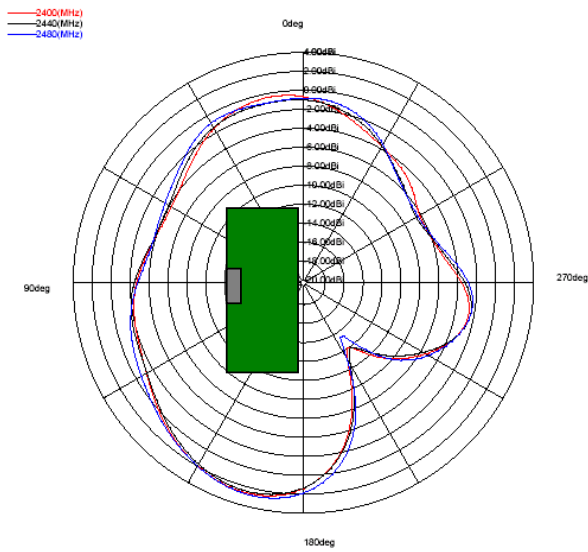

ZY-PLANE

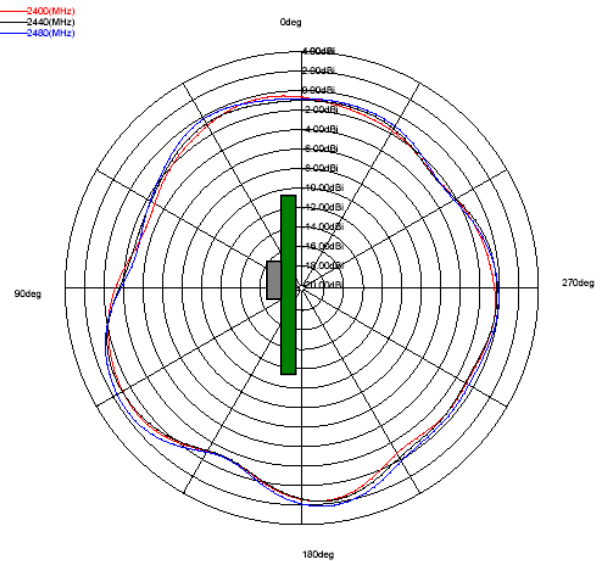

XY-PLANE

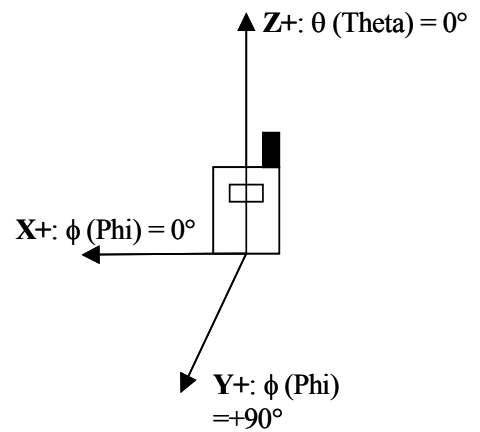
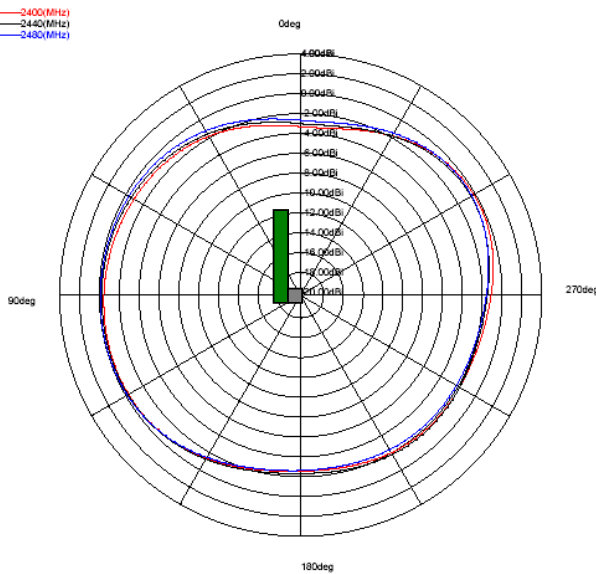

2.4/5 GHz Dualband WiFi Ceramic Chip Antenna

Ground cleared under antenna, clearance area **11.60 mm x 6.25 mm**

5 GHz Typical Electrical Characteristics (T=25 °C)

Measured on the 80 x 37mm test board with matching circuit, 1.5nH shunt inductor

Typical Return Loss S11

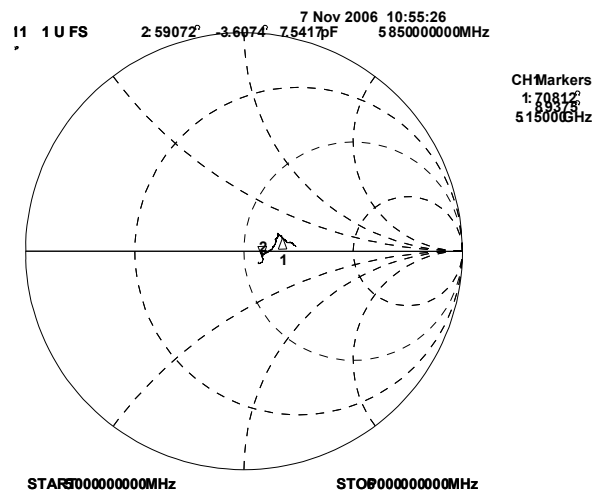
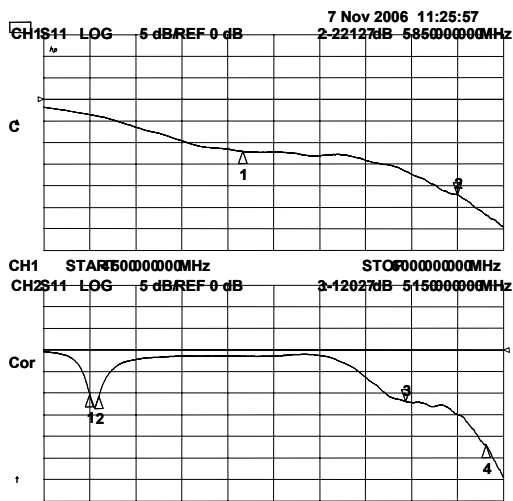

Free space efficiency and maximum gain

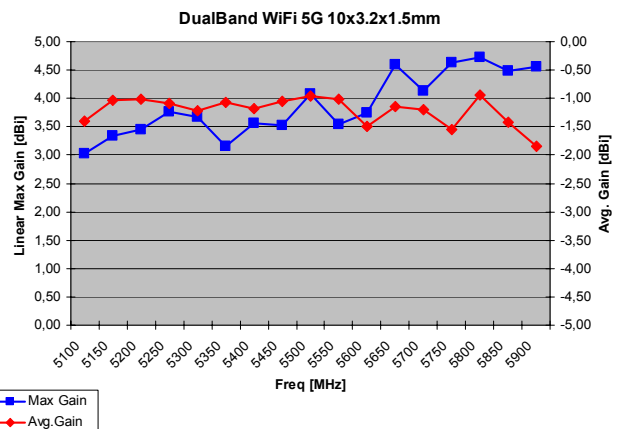
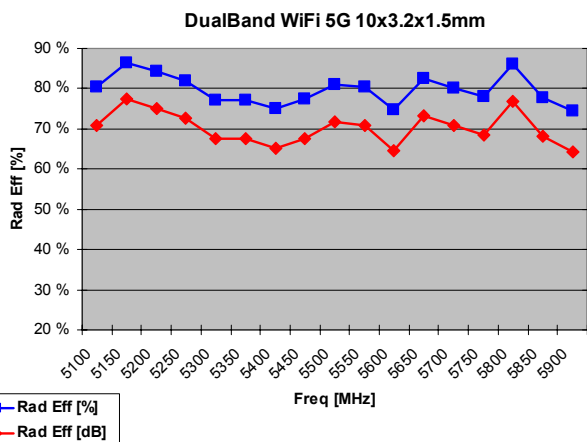

2.4/5 GHz Dualband WiFi Ceramic Chip Antenna

Ground cleared under antenna, clearance area **11.60 mm x 6.25 mm**

5 GHz Typical Free Space Radiation Patterns

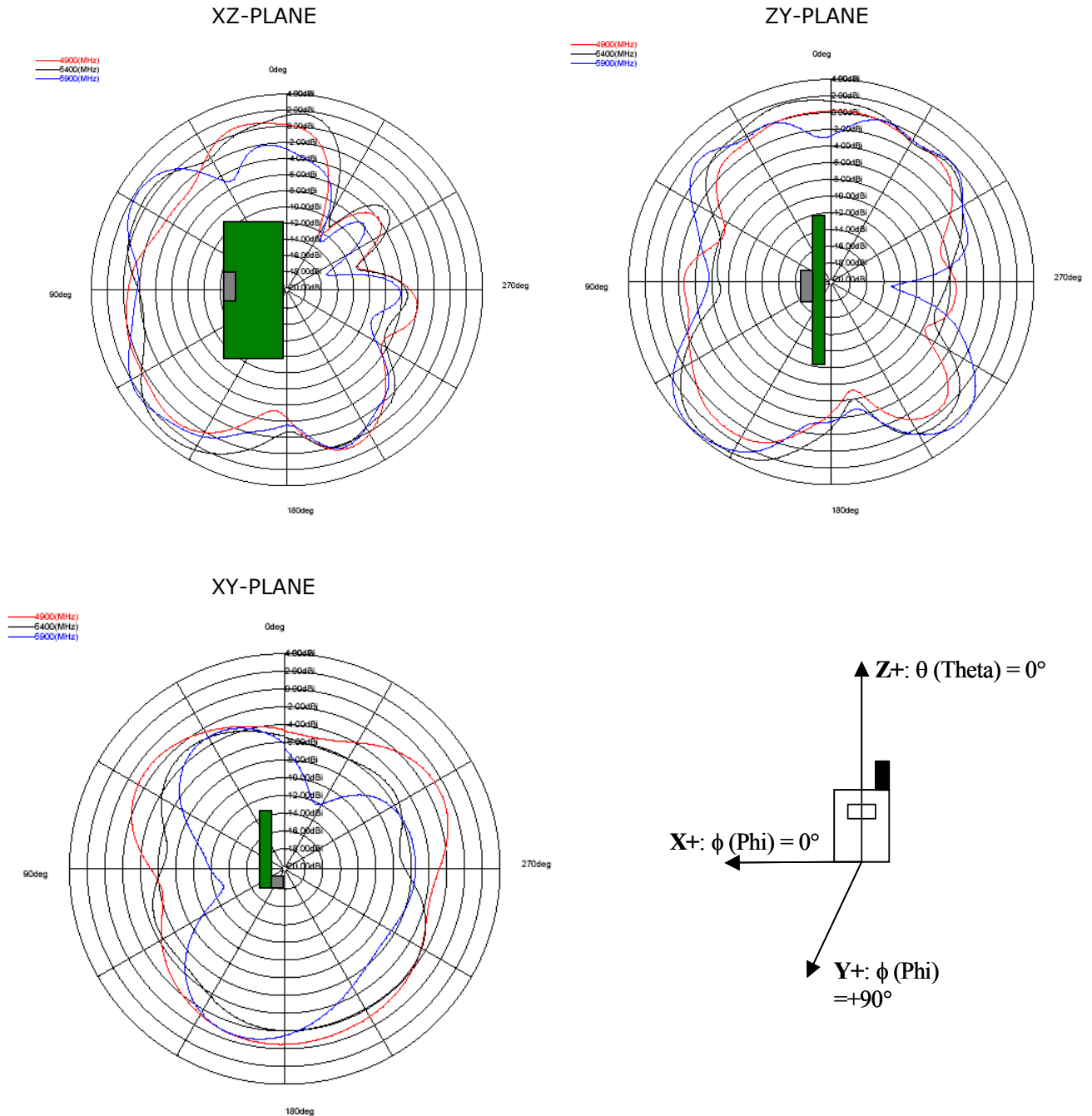

2.4/5 GHz Dualband WiFi Ceramic Chip Antenna

Packing

General

Tape and reel packing is used. Carrier tape, reel and box dimensions are presented in following pictures.

Carrier tape

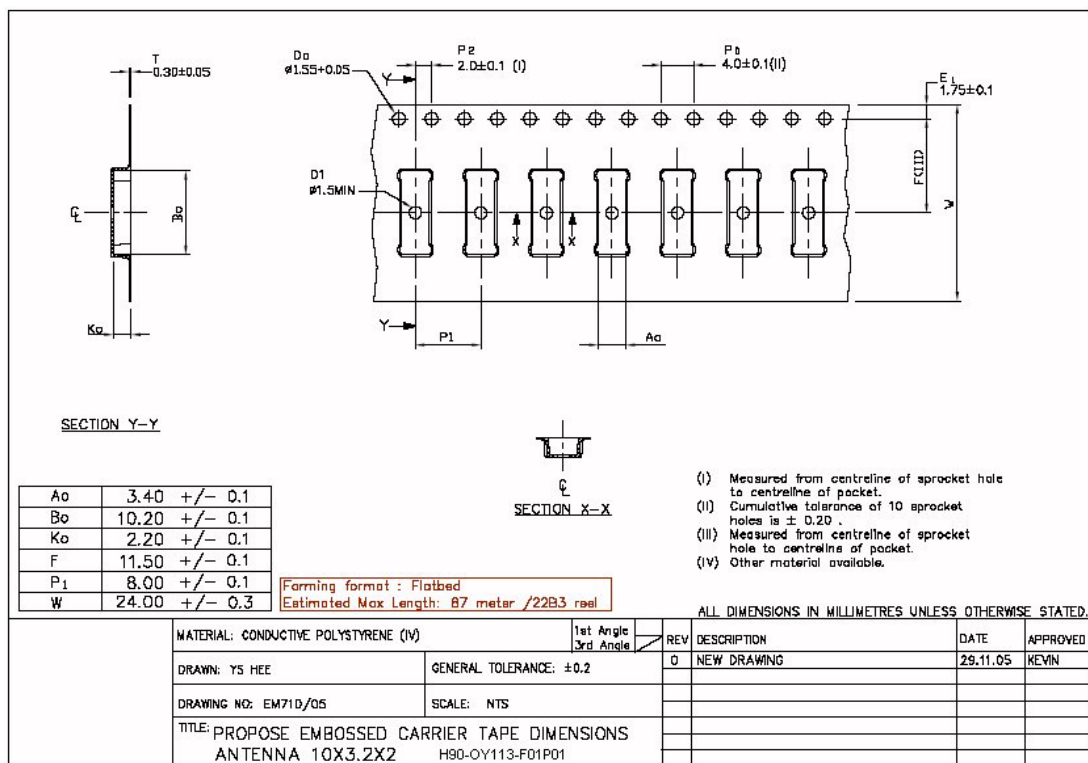

Block orientation

Antenna soldering pads facing down to the bottom of the carrier tape.

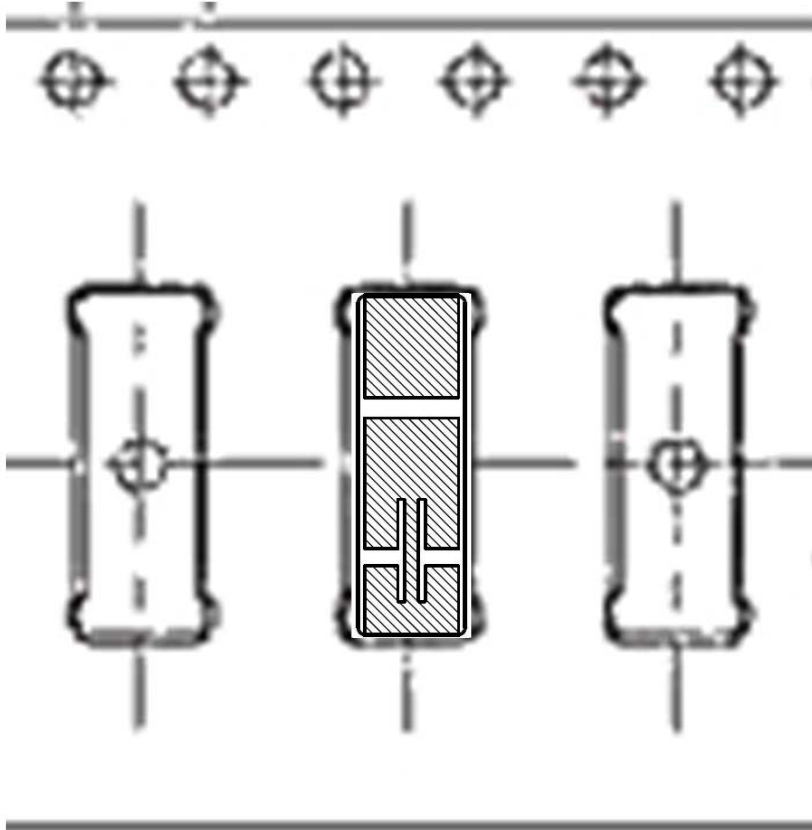

Packing form

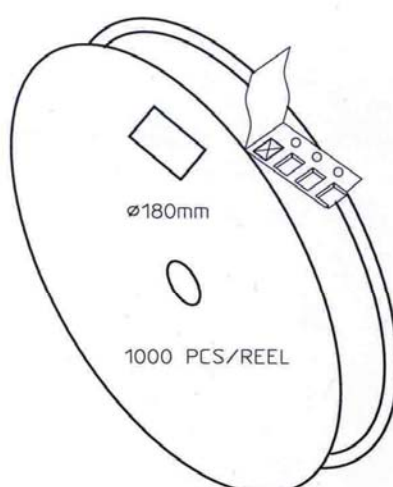
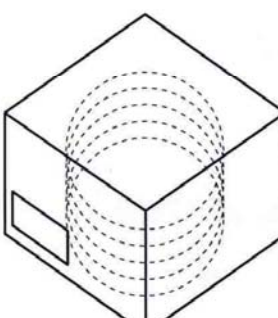
CARRIER TAPE H85-00168
width=24,00 depth=2.20
COVER TAPE H85-00159
width=21.20

LENGTH OF TAPE:

- Leader section: min 350 mm before component section
- Trailer section: min 40 mm after component section.

Empty part cavities at leader and trailer section of the tape must be sealed with top cover tape.

BOX H85-00128 (182x182x125)	1 pcs
- LABEL	1 pcs/BOX
REEL H85-00160 (D180, W28)	4 pcs
- REEL LABEL	1 pcs/REEL

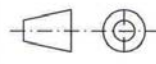
MATERIAL				
HANDLINGS				
		RATIO	DRWN 160107 PeHa H	
			DGNER	G
			CHKD	F
			APPRD	E
			APPRD BY	D
PRODUCT H90-OY113-F01P01			C	
DENOMINATION PACKING FORM			B	
			A	
		VERSION	MOD/DATE/NAME	

2.4/5 GHz Dualband WiFi Ceramic Chip Antenna

Mechanical Outline

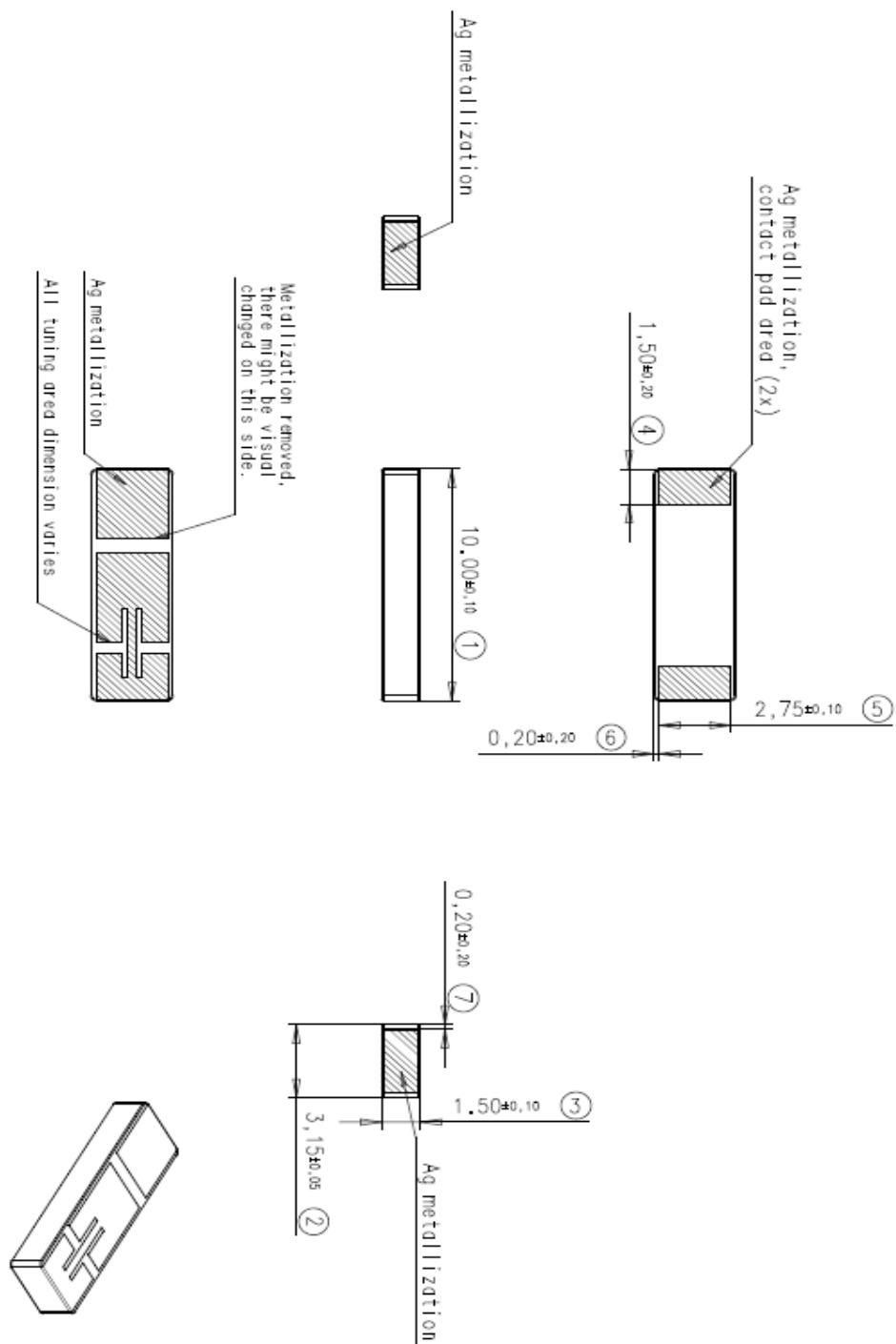

For More Information, please contact:

Pulse Finland Oy

Takatie 6
Fin-90440 Kempele
Finland
Tel. +358 207 935 500
Fax +358 207 935 501 (sales)

Domicile: Kempele
Business ID: 1933992-8
firstnamesurname@pulseeng.com
www.pulseeng.com/antennas

Pulse World Wide Headquarters

12220 World Trade Drive
San Diego, CA 92128
U.S.A

Tel. +1 858 674 8100
Fax +1 858 674 826
www.pulseeng.com

This is a "Preliminary" product application notes. Products mentioned on this application notes are in development and in the process of being qualified. These products are not fully released nor are they in production. Features, specifications and performance of products offered are subject to change without notice. Other brand and product names mentioned herein may be products and/or registered trademarks of their respective ones. For current info on this product, please contact the Pulse San Diego office.

© Copyright, 2006. Pulse Finland Oy. All rights reserved.

Pulse Finland Oy

Takatie 6
90440 Kempele, Finland
Tel: +358 207 935 500
Fax: +358 207 935 501

Domicile: Kempele
Business ID: 1933992-8
firstnamelastname@pulseeng.com
www.pulseeng.com/antennas



© 2006. All Rights Reserved.