

# User manual



Long Range Wireless HDMI/SDI HD Video Transmission Suite

### ■ Product model and standard:

The Long Range Wireless HDMI/SDI Transmission Suites utilize today's most advanced wireless video transmission technology, which can realize the broadcast-class and uncompressed 3G SDI/HDMI HD video signal transmitted with no compression and zero delay. The suite includes one transmitter and one receiver, where the transmitter provides a 3G/HD SDI input and a HDMI input, and the receiver also provides a 3G/HD SDI output and a HDMI output. The wireless HD suite have 2 stick antennas in transmitter side, and 5 stick antennas in receiver side, and it can work in 5.1-5.9GHz frequency band and be flexibly software configured to licensed or ISM band of global different regions, as well as the side panel of both transmitter and receiver have been installed a frequency select knob, which provides maximum 10 workable frequency channels, and supports maximum 4 sets working simultaneously. The wireless suite can accept wide range DC power input, which is suitable for many kinds of camera battery model. The suite also can sustain  $\pm 8$  kV ESD (HBM, contact discharge), the industry class metal case and professional heat design would guarantee most rigorous reliability.

## ■ Main features:

- HDMI 1.3spec supports
- HDMI and 3G SDI inputs and outputs
- Highest resolution 1080p 60Hz, no delay and no compression
- AES-128 encryption with air interface HD video data stream
- Support point to point, and point to multi points network topology
- Each RX can be paired to the unique TX in factory
- 5GHz ISM frequency band, maximum 10 frequency channels selected by user knob, coexist with WIFI
- Maximum transmission distance is 300 meters
- Signal indicators for DC power status, video status and receiver RSSI
- Wide range power voltage input, adapt most kinds of camera batteries
- Optional Sony F970,V-mount and G-mount, battery buckle, convenient for field battery install and replacement
- Any input and output ports with  $\pm 8$  kV ESD protection level (HBM, contact discharge)
- Industrial metal case, stable and reliable

# About

## ■ Parameters:

|                      | Transmitter   | Receiver  |
|----------------------|---|---|
| Interface            | SDI Input ( BNC Female ) ; HDMI Input(Type A female); 2 Antenna port(RP-SMA male) ; DC input (4 pin LEMO female)  | SDI Output ( BNC Female ) ; HDMI Output(Type A female); 5 Antenna port(RP-SMA male) ; DC input (4 pin LEMO female)  |
| Supply Voltage Range | 7-36V DC  | 7-36V DC  |
| Power Consumption    | < 6.5 W   | < 7.5 W   |
| Size                 | (L x W x H): 120x 70 x 25mm<br>don't include antennas   | (L x W x H): 160x 110 x 25mm<br>don't include antennas  |
| Mass                 | 380g  | 540g  |
| Input Video Format   | HDMI:525i, 625i, 720p 50/59.94/60, 1080i 50/59.94/60, 1080p23.98/24/25/29.9/30/50/59.94/60;HDMI Type A SDI:3G, HD, and SD-SDI (auto-selected), SMPTE-259/274/292/296/372/424/425;1x BNC | /   |
| Output Video Format  | /   | HDMI:525i, 625i, 720p 50/59.94/60, 1080i 50/59.94/60,1080p23.98/24/25/29.9/30/50/59.94/60;HDMI Type A SDI:3G, HD, and SD-SDI (auto-selected), SMPTE-259/274/292/296/372/424/425; 1x BNC |
| Input Audio Format   | SDI embedded 2 channel 24 bit/48KHz   | /   |
| Output Audio         | /   | SDI embedded 2 channel 24 bit/48KHz   |
| Signal Indicator     | POWER-Green; VIDEO-Yellow   | POWER-Green; Wireless RSSI-Green (5 LEDs); VIDEO-Yellow   |
| Frequency Band       | 5.1-5.9GHz,configurable with China, North American, Europe,etc  | 5.1-5.9GHz,configurable with China, North American, Europe,etc  |
| Modulation Mode      | OFDM 16QAM  | OFDM 16QAM  |
| Transmission Power   | Maximum 21dBm   | /   |
| Receiver Sensitivity | /   | -75dBm  |
| Occupied Bandwidth   | 40MHz   | 40MHz   |
| Temperature Range    | 0~40°C(operating condition);<br>-20~60°C(Storage)   | 0 ~ 40°C (operating condition);<br>-20~60°C(Storage)  |
| Compliance           | FCC; CE.  | FCC; CE.  |

# About

## ■ Product introduction

### Transmitter:

- 1) 1/4-20 screw hole
- 2) RP-SMA male antenna connector
- 3) Video input indicator, 1 yellow LED
- 4) Power on Indicator, 1 green LED
- 5) Frequency selection knob, 0-9
- 6) 3G SDI input
- 7) HDMI Input
- 8) DC power switch
- 9) DC input, LEMO 4-pin B series connector

### Receiver:

- 1) 1/4-20 screw hole
- 2) RP-SMA male antenna connector
- 3) RSSI(wireless received signal strength indicator), 5 green LEDs
- 4) Video input indicator, 1 yellow LED
- 5) Power on Indicator, 1 green LED
- 6) Frequency selection knob, 0-9
- 7) 3G SDI Output
- 8) HDMI Output
- 9) DC power switch
- 10) DC input, LEMO 4-pin B series connector

### Transmitter:

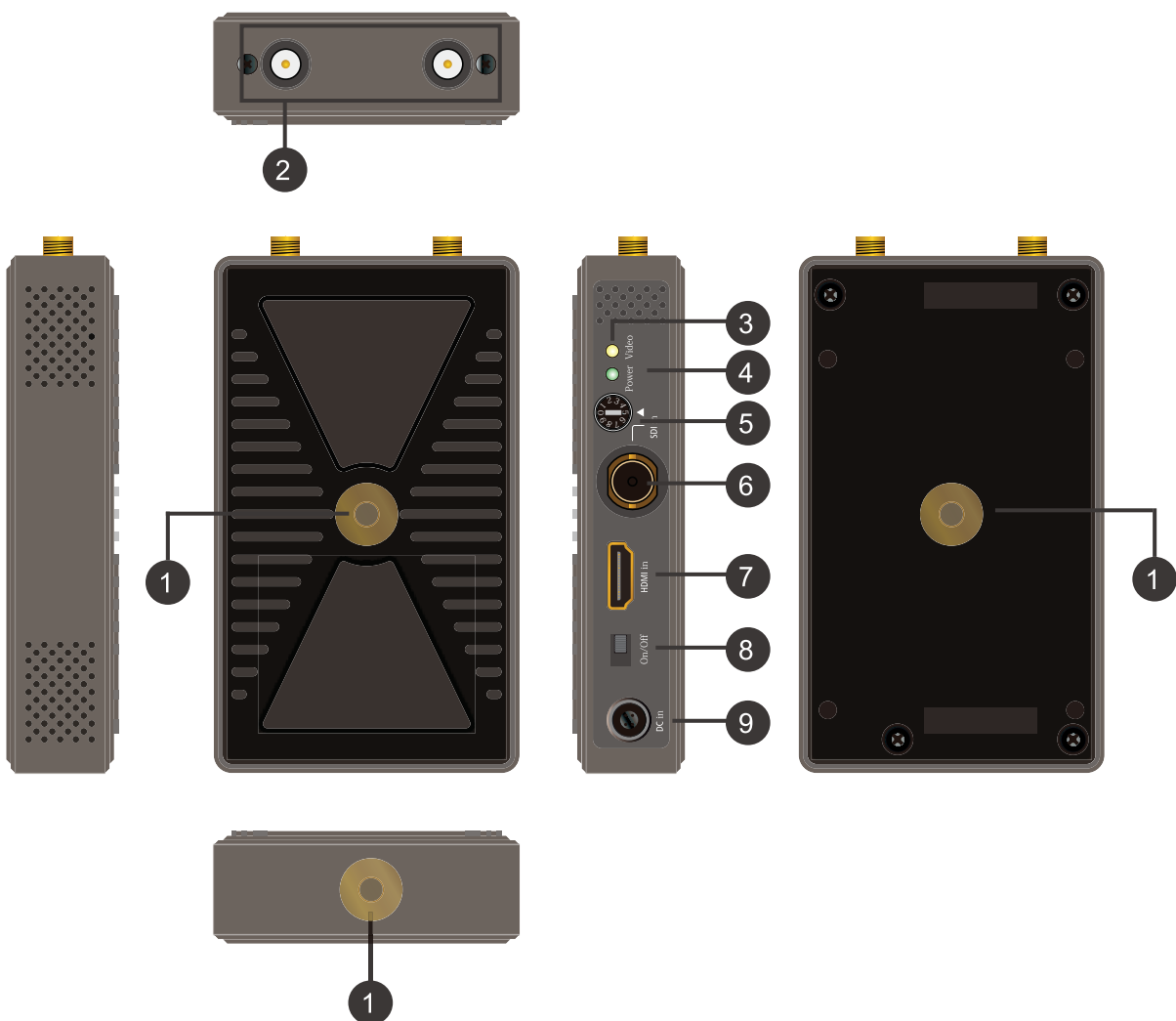

# About

Receiver:

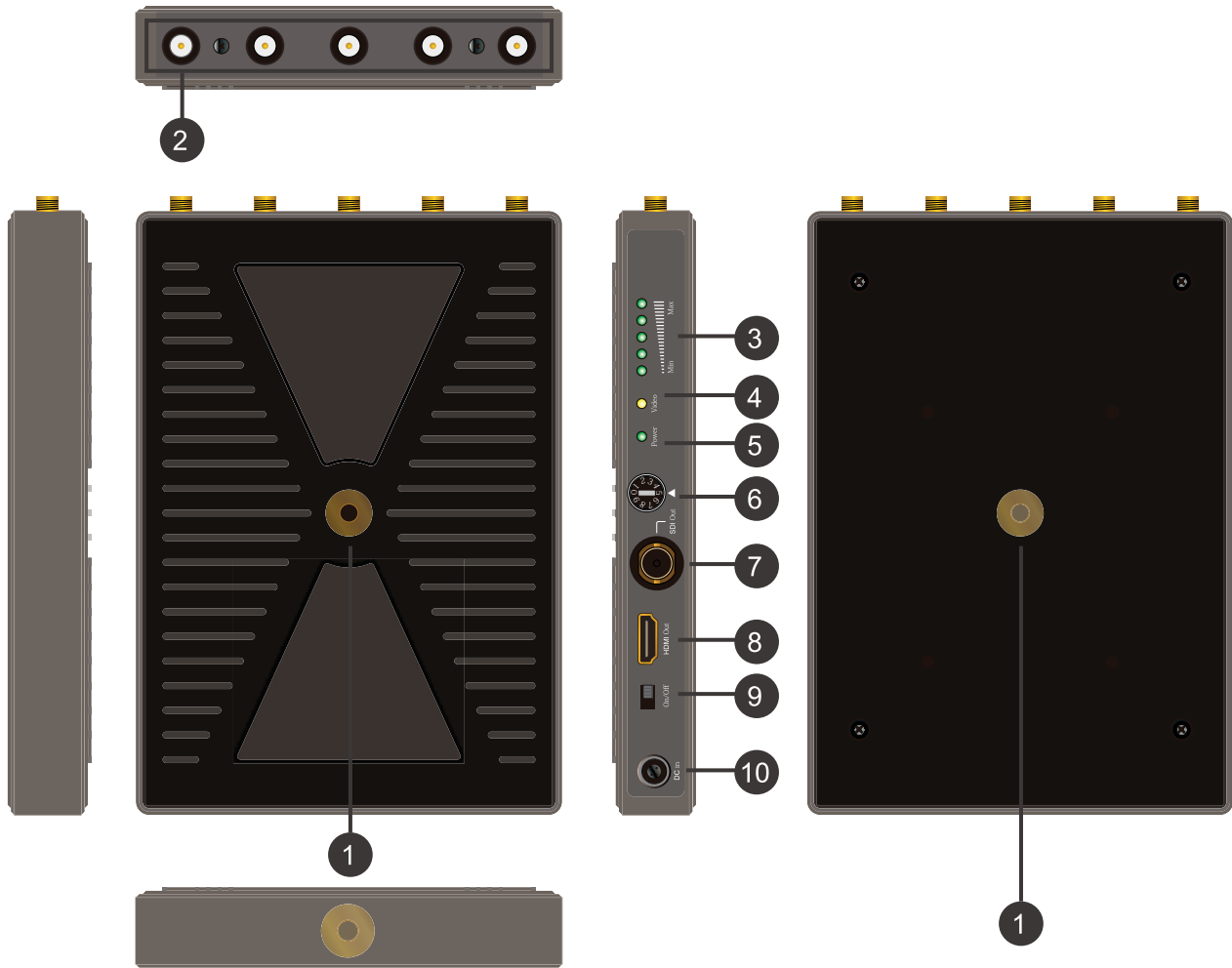

## ■ Packing list

- 1 unit transmitter
- 1 unit receiver
- 8 pcs 5GHZ omni-directional and high efficiency antennas (SMA female)
- 2×flat screwdrivers
- 1×7" articulating arm
- 1×1/4-20 screw to ISO518 hot shoe converter
- 1× crab clam
- 2× D-Tap to 4-pin lemo converter cable
- 1 user manual
- 355X272X105.38MM tool case packing

# Installation

## ■ Installation details and cautions

### ● Transmitter side

a) Install 2 omni-directional and high efficiency antennas to transmitter's RP-SMA male antenna connectors.

b) There are 3 1/4-20 screw nuts in transmitter metal case, which are located on surface, rear and bottom. So the user can utilize a 1/4 screw to ISO518 hot-shoe converter fix the transmitter on camera.

c) Install battery into battery buckle if your product model includes battery buckle option; please note the battery model must match the battery buckle type.

d) The user can also utilize a subsidiary LEMO 4 pin male to D-type receptacle power cable to get power input from an outside power source.

e) All TX installation guidelines see below figure.

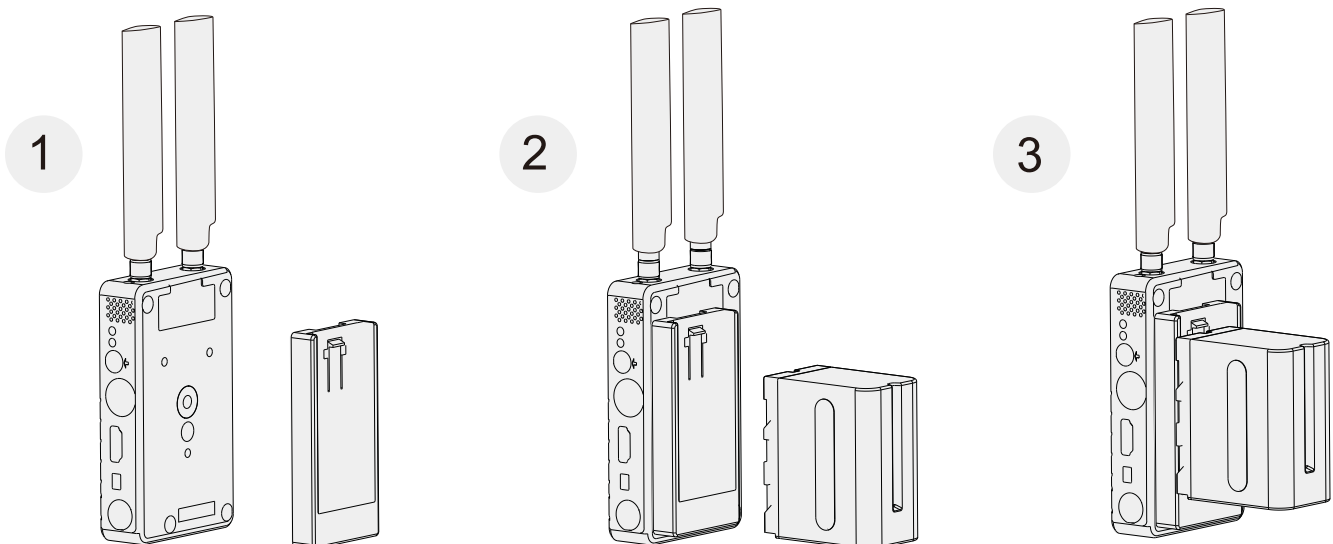

# Installation

## ● Receiver side

a) Install 5 pcs omni-directional and high efficiency antennas to receiver's RP-SMA male antenna connectors.

b) There are a 1/4-20 screw nut in the surface side of receiver. The user can utilize a 1/4 screw fix the subsidiary metal hook with the receiver.

c) Install battery into battery buckle if your product model includes the option of battery buckles; please note the battery model must match the battery buckle type.

d) The user can also utilize a subsidiary LEMO 4 pin-male to D-type receptacle power cable to get power input from an outside power source.

e) All RX installation guidelines see below figure.

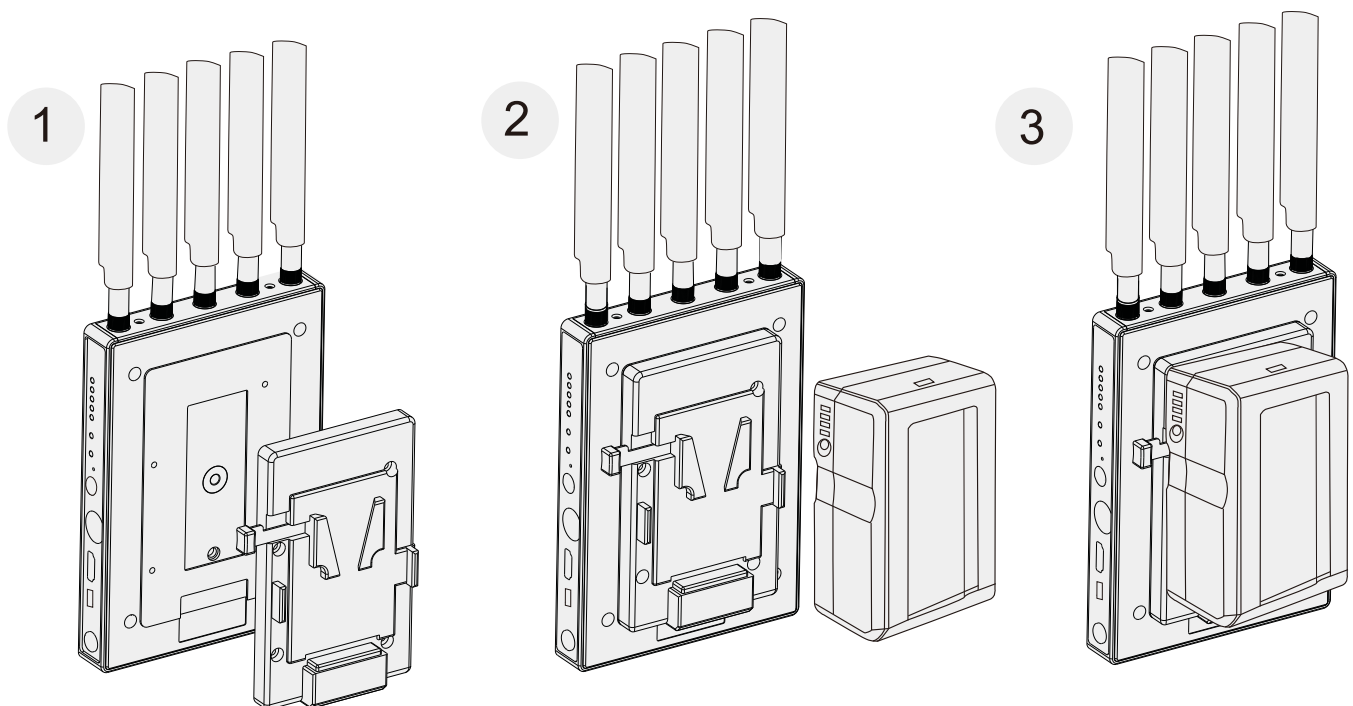



# Installation

## ■ Typical connection instruction

Connect camera SDI or HDMI output to transmitter SDI or HDMI input port, and the transmitter can be fixed in hot-shoe port of the camera. Connect HDMI or SDI output port of the receiver to SDI or HDMI input port of the HD monitor. Make sure all antennas and batteries are equipped normally. See below figure.



## Operation instruction

### ■ Getting started

After finishing all steps above, system is workable, follow below steps.

- a) Ensure the video source output of the camera is OK, and the HD monitor is power on and switched to connected video input port.
- b) Ensure all inputs, output SDI or HDMI cables are connected.
- c) Ensure all antennas are installed, and it is better to keep TX 2 antennas and RX 5 antennas with orthogonal angle each other for best RF performance. Looks like below figure.

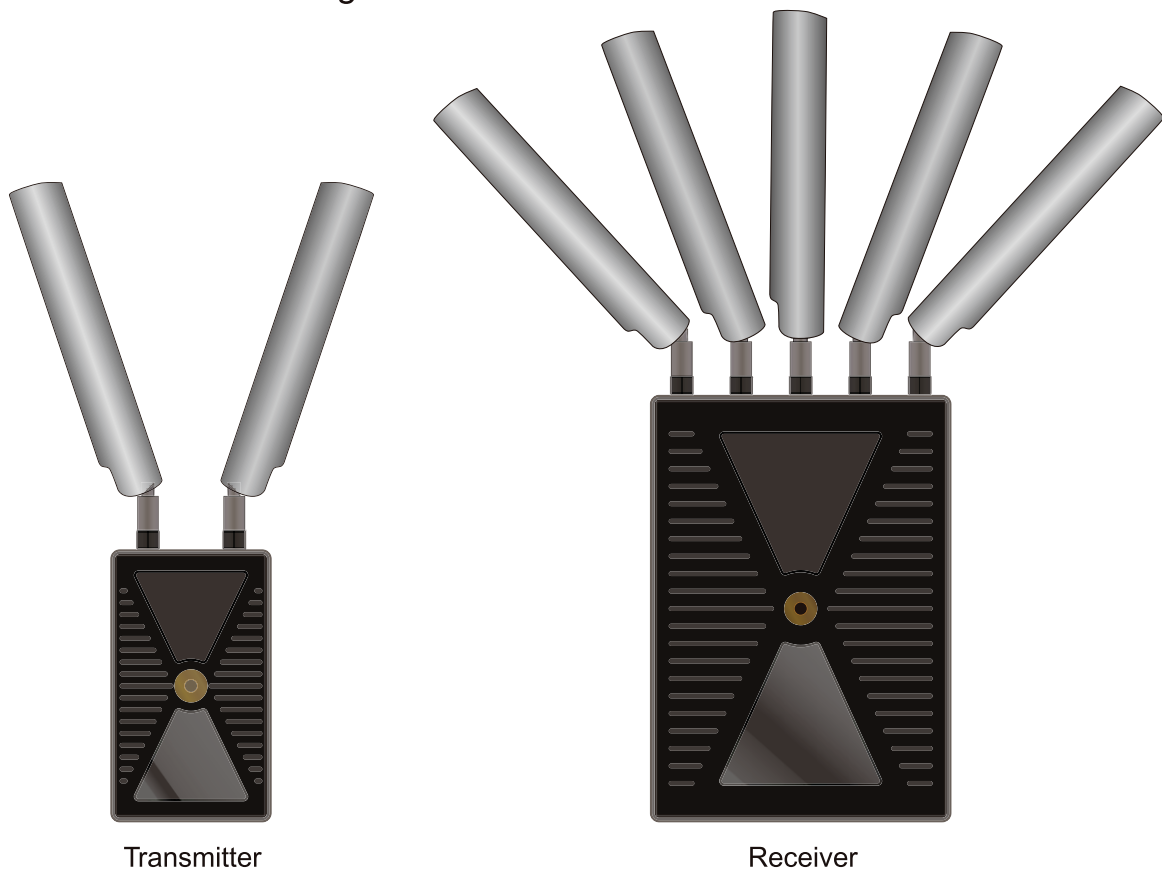

- d) Ensure both the transmitter and receiver installed batteries or DC input ports connected to outside power sources. Then toggle power switch of transmitter and receiver to 'ON' respectively then 'Power' indicator will light.
- e) Ensure the frequency knobs of transmitter and receiver are set with the same number and this will make sure the transmitter and receiver work with same RF
- f) If the camera is on and video input is OK, TX side 'video' indicator will light.

## Operation instruction

g) Before RX setup wireless link with TX, 5 'RSSI' indicators and "video" indicators will be off; when wireless link is OK, 'RSSI' indicators will light first, and 'RSSI' will indicate the received RF signal strength. If the receiver detects normal wireless video internally from air interface, 'Video' indicator will light. Before that if SDI or HDMI video out port of the receiver has HD monitor connected it will display an OSD of 'Link connecting.....' looks like below picture.

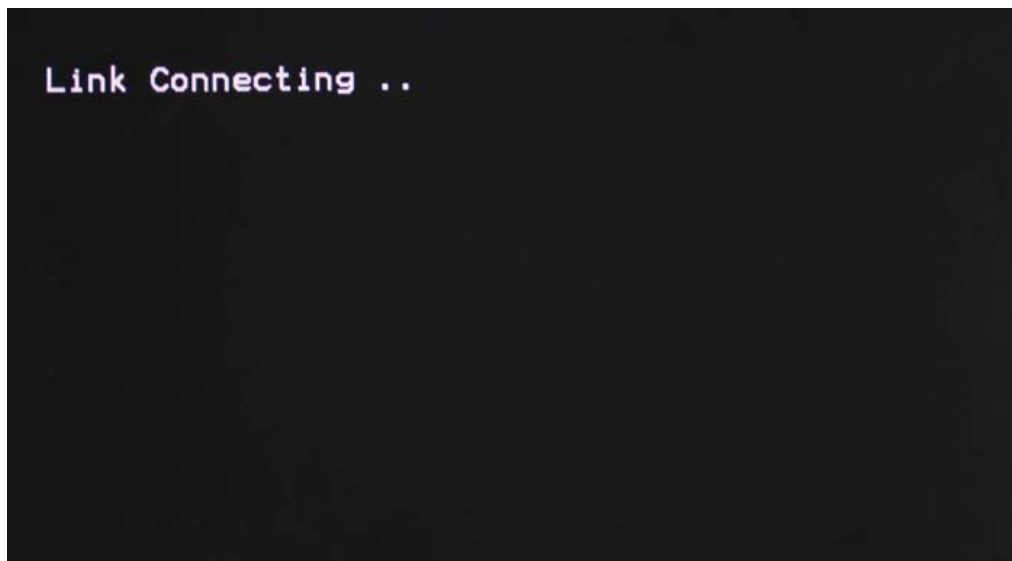

h) The system will spend 20-30 seconds on constructing communication link, and the real link period will depend on the current wireless channel condition. When wireless link is set up, 'RSSI' light will light and indicate current received wireless signal strength, as well 'video' indicators will light, and then connected HD monitor will display the video and audio accordingly.

i) For the best wireless transmission performance, it need install the transmitter and receiver more than 2m above the ground and keep the same height, and make sure no obstacles between them; Moreover, it is the best to keep the transmitter antennas and the receiver antennas face to face, and don't turn round any sides with too big angle. The real transmission distance is also relevant to current air electromagnetic environment, because the system works in ISM band, it is exposure to all kinds of 5GHz band air interference, we suggest the users should do a manual frequency sweep by adjusting frequency selection knob with a circle before using the equipment, then choose the best frequency channel for stable performance.

## Operation instruction

### ■ Input video ports selection of transmitter

The transmitter has a 3G SDI video input port and a HDMI video input port, and the system will detect valid video source automatically of SDI and HDMI port, then switch it as main video input channel. If both SDI and HDMI have valid video inputs, the system will take SDI input as priority.

### ■ RSSI indicators

The receiver will calculate received RF signal strength internally and 5 “RSSI” LEDs will be used to indicate wireless signal power and quality. The user can observe the RSSI LED status to know if the current wireless link is reliable or not.

| Lit RSSI LEDs Volume | Wireless Link Quality | Video Quality       |
|----------------------|-----------------------|---------------------|
| 4-5                  | Strong                | Best                |
| 2-3                  | Middle                | Good                |
| 1 or no lit LED      | Weak                  | Visible Video Noise |

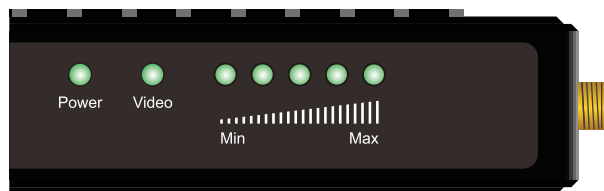

### ■ Frequency selection and configuration

The wireless suite can work in 5.1-5.9GHz frequency band and be flexibly software configured to licensed or ISM band of global different regions as well as the side panel of both transmitter and receiver has been installed a frequency select knob, which provide maximum 10 workable frequency channels, and support maximum 4 sets working simultaneously. See below frequency knob figure.

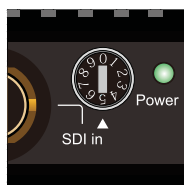

# Maintenance

## ■ Storage conditions

Products storage temperature should be  $-20^{\circ}\text{C}\sim 60^{\circ}\text{C}$ . For long time storage requirement, please use original carbon boxes, and avoid from high humid, acid base or dusty place.

## ■ Maintenance

### Warning

To ensure your safety, please choose well-known brand DC batteries, and guarantee suitable work conditions that batteries manual mentioned.

### ■ Normal problems

#### a) No output on display

Check TX and RX power first, and see if TX or RX battery is powered from external power, then check if TX antennas and RX antennas are installed right. After that, check 'video' indicator, if TX 'video' indicator is not light, then check SDI or HDMI cable and video source please. Finally may check input video format is compatible with this product specs.

#### b) Poor output video quality

Check if SDI or HDMI input or output cable is plugged well, then checks how many receiver side 'RSSI' LEDs are lit, there should be 2-3 RSSI LEDs lit if the user want to get better video quality; if there is only 1 RSSI LED lit, that means the received wireless signal is weak and should shorten the transmission distance.

## FCC Statement

This device complies with part 15 of the FCC rules. Operation is subject to the following two conditions: (1) this device may not cause harmful interference, and (2) this device must accept any interference received, including interference that may cause undesired operation.

Changes or modifications not expressly approved by the party responsible for compliance could void the user's authority to operate the equipment.

NOTE: This equipment has been tested and found to comply with the limits for a Class B digital device, pursuant to part 15 of the FCC Rules. These limits are designed to provide reasonable protection against harmful interference in a residential installation. This equipment generates uses and can radiate radio frequency energy and, if not installed and used in accordance with the instructions, may cause harmful interference to radio communications. However, there is no guarantee that interference will not occur in a particular installation. If this equipment does cause harmful interference to radio or television reception, which can be determined by turning the equipment off and on, the user is encouraged to try to correct the interference by one or more of the following measures:

- Reorient or relocate the receiving antenna.
  - Increase the separation between the equipment and receiver.
  - Connect the equipment into an outlet on a circuit different from that to which the receiver is connected.
  - Consult the dealer or an experienced radio/TV technician for help
- important announcement

## Important Note:

### Radiation Exposure Statement

This equipment complies with FCC radiation exposure limits set forth for an uncontrolled environment. This equipment should be installed and operated with minimum distance 20cm between the radiator and your body.

This transmitter must not be co-located or operating in conjunction with any other antenna or transmitter.