



H.B. Compliance Solutions

Intentional Radiator Test Report

For the

PROPEL Orthodontics, LLC

VPro+ Model ASM-20023

Tested under

The FCC Rules contained in Title 47 of the CFR, Part 15.209

Prepared for:

PROPEL Orthodontics, LLC

394 South Abbott Ave.,

Milpitas, CA 95035

Prepared By:

H.B. Compliance Solutions

5005 S. Ash Avenue, Suite # A-10

Tempe, Arizona 85282

Reviewed By:

Hoosamuddin Bandukwala



Cert # ATL-0062-E

Engineering Statement: The measurements shown in this report were made in accordance with the procedure indicated, and the emissions from this equipment were found to be within the limits applicable. I assume full responsibility for the accuracy and completeness of these measurements, and for the qualifications of all persons taking them. It is further stated that upon the basis of the measurement made, the equipment tested is capable of operation in accordance with the requirements of Part 15 of the FCC Rules under normal use and maintenance. All results contained herein relate only to the sample tested.

Report Status Sheet

| Revision # | Report Date | Reason for Revision |
|------------|-------------------|--------------------------------------|
| ∅ | July 4, 2018 | Initial Issue |
| 1 | August 7, 2018 | TCB Comments |
| 2 | September 6, 2018 | Addition of Loop Antenna below 30MHz |

Table of Contents

| | |
|---|----|
| EXECUTIVE SUMMARY | 4 |
| 1. Testing Summary | 4 |
| EQUIPMENT CONFIGURATION | 5 |
| 1. Overview | 5 |
| 2. Test Facility | 6 |
| 3. Description of Test Sample | 6 |
| 4. Equipment Configuration | 6 |
| 5. Support Equipment | 8 |
| 6. Ports and Cabling Information | 8 |
| 7. Method of Monitoring EUT Operation | 8 |
| 8. Mode of Operation | 8 |
| 9. Modifications | 8 |
| 10. Disposition of EUT | 8 |
| Criteria for Un-Intentional Radiators | 9 |
| 1. Radiated Emissions | 9 |
| Emissions Tests Calculations | 10 |
| Criteria for Intentional Radiators | 15 |
| 2. Conducted Emissions | 15 |
| 2. Occupied Bandwidth | 19 |
| 5. Radiated Emissions | 21 |
| 6. Measurement Uncertainty | 25 |

EXECUTIVE SUMMARY

1. Testing Summary

These tests were conducted on a sample of the equipment for the purpose of demonstrating compliance with Part 15.209. All tests were conducted using measurement procedure from ANSI C63.4-2014, American National Standard for Methods of Measurement of Radio-Noise Emissions from Low-Voltage Electrical and Electronic Equipment in the range of 9kHz to 40GHz as appropriate.

| Test Name | Test Method/Standard | Result | Comments |
|------------------------------------|-----------------------------|--------|----------|
| Unintentional Radiated Emissions | 15.109 | Pass | |
| A/C Power Line Conducted Emissions | 15.207(a) | Pass | |
| Occupied Bandwidth | 15.215 | Pass | |
| Radiated Fundamental Emissions | 15.209(a) | Pass | |
| Radiated Spurious Emissions | 15.209(a), 15.205, 15.35(C) | Pass | |



EQUIPMENT CONFIGURATION

1. Overview

H.B Compliance Solutions was contracted by Xekera Systems to perform testing on the VPro+ Vibration Head under the purchase order number 500-10.

This document describes the test setups, test methods, required test equipment, and the test limit criteria used to perform compliance testing of the PROPEL Orthodontics, VPro+ Vibration Head.

The tests were based on FCC Part 15 Rules. The tests described in this document were formal tests as described with the objective of the testing was to evaluate compliance of the Equipment Under Test (EUT) to the requirements of the aforementioned specifications. PROPEL Orthodontics should retain a copy of this document and it should be kept on file for at least five years after the manufacturing of the EUT has been permanently discontinued. The results obtained relate only to the item(s) tested.

| | |
|--|--|
| Product Name: | VPro+ |
| Model(s) Tested: | ASM-20023 |
| FCC ID: | 2AP6HASM0023 |
| Supply Voltage Input: | Primary Power : 120VAC |
| Frequency Range: | 0.156MHz |
| No. of Channels: | 1 |
| Type(s) of Modulation: | Sinewave |
| Range of Operation Power: | 2.69 x10 ⁻¹¹ Watts (Radiated) |
| Emission Designator: | N/A |
| Channel Spacing(s) | None |
| Test Item: | Pre-Production |
| Type of Equipment : | Fixed |
| Antenna Requirement (§15.203) : | Type of Antenna: Integral Loop Gain of Antenna: 0dBi |
| Environmental Test Conditions: | Temperature: 15-35°C Humidity: 30-60% Barometric Pressure: 860-1060 mbar |
| Modification to the EUT: | None |
| Evaluated By: | Staff at H.B Compliance Solutions |
| Test Date(s): | 06/13/2018 till 06/18/2018 |
| | |
| | |



2. Test Facility

Radiated Emission testing below 30MHz was performed at Artesyn Embedded Technologies. This facility is located at 2900 S. Diablo Way, Suite 190, Tempe, AZ 85282. All equipment used in making physical determination is accurate and bears recent traceability to the National Institute of Standards and Technology.

Test facility at Artesyn Embedded Technologies is an A2LA accredited test site. The A2LA certificate number is 2716.01. The scope of accreditation covers the FCC Method - 47 CFR Part 15, ICES-003, CISPR 22, AS/NZS 3548 and VCCI

All other testing was performed at H.B. Compliance Solutions. This facility is located at 5005 S. Ash Avenue, Suite # A-10, Tempe AZ-85282. All equipment used in making physical determination is accurate and bears recent traceability to the National Institute of Standards and Technology.

Radiated Emissions measurements were performed in a GTEM chamber (equivalent to an Open Area Test Site). In accordance with §2.948(a)(3), a complete site description is contained at H.B. Compliance Solutions.

Test facility H.B. Compliance Solutions is an ANAB accredited test site. The ANAB certificate number is L2458. The scope of accreditation can be found on ANAB website www.anab.org

3. Description of Test Sample

The PROPEL Orthodontics, VPro+ can be used by the patient manually. It is a rechargeable powered device that applies a gentle vibration to the occlusal surface of the teeth to seat the aligner. The device consists of the following components: a vibration unit, mouth piece adapter, chagrining cable, and wall charging adapter. Once the vibration unit and the mouthpiece adapter are coupled together the device can be manually applied to the occlusal surface of the teeth of the user. The VPro+ charging cradle includes a 156kHz Inductive Coupling wireless charging radio and a 2.4GHz Bluetooth BLE radio. The 2.4GHz Bluetooth BLE is a pre-certified FCC module Gecko BGM121 (FCC ID # QQQBGM12LMA)

4. Equipment Configuration

| Ref. ID | Name / Description | Model Number | Serial Number |
|---------|----------------------|--------------|---------------|
| # 1 | VPro+ Vibration Head | ASM-20023 | None |

| | | | |
|-----|--------------------------------------|-----|-----|
| # 2 | Dock/Cradle (wireless charging unit) | N/A | N/A |
|-----|--------------------------------------|-----|-----|

Table 1. Equipment Configuration

5. Support Equipment

All support equipment supplied is listed in the following Support Equipment List.

| Ref ID | Name / Description | Manufacturer | Model # | Serial # |
|--------|---------------------|--------------|-------------------|----------|
| # 3 | Cell Phone | Samsung | SM-J701M | None |
| # 4 | AC/DC Power Adaptor | N/A | STR-084-050-1000U | None |

Table 2. Support Equipment

6. Ports and Cabling Information

| Ref ID | Port name on the EUT | Cable Description | Qty. | Length (m) | Shielded? (Y/N) | Termination Box ID & Port ID |
|--------|----------------------|-------------------|------|------------|-----------------|------------------------------|
| # 5 | Power | 2 wire | 1 | 1 | N | AC Outlet |

Table 3. Ports and Cabling Information

7. Method of Monitoring EUT Operation

A test receiver will be used to monitor the data transmission from the EUT.

8. Mode of Operation

The EUT will be configured to transmit at maximum power level. Test mode was provided to keep the unit in continuous transmit mode. These settings were created for testing purpose only.

9. Modifications

9.1 Modifications to EUT

No modifications were made to the EUT

9.2 Modifications to Test Standard

No Modifications were made to the test standard.

10. Disposition of EUT

The test sample including all support equipment submitted to H.B Compliance Solutions for testing will be returned to Xekera Systems upon completion of testing & certification

Criteria for Un-Intentional Radiators

1. Radiated Emissions

| | | | |
|-----------------------------|---------|--------------------------|-------------|
| Test Requirement(s): | §15.109 | Test Engineer(s): | Jerry Mejak |
| Test Results: | Pass | Test Date(s): | 06/13/2018 |

Test Procedures:

The final radiated emissions test was performed using the parameters described above as worst case. That final test was conducted at a facility that meets the ANSI C63.4 NSA requirements. The frequency range noted in the data sheets was scanned/tested at that facility. Emissions were maximized as specified, by varying table azimuth, antenna height, and manipulating cables.

Using the mode of operation and configuration noted within this report, a final radiated emissions test was performed. The frequency range investigated (scanned), is also noted in this report. Radiated emissions measurements were made at the EUT azimuth and antenna height such that the maximum radiated emissions level will be detected. This requires the use of a turntable and an antenna positioner. The preferred method of a continuous azimuth search is utilized for frequency scans of the EUT field strength with both polarities of the measuring antenna. A calibrated, linearly polarized antenna was positioned at the specified distance from the periphery of the EUT.

Note: The specified distance is the horizontal separation between the closest periphery of the EUT and the center of the axis of the elements of the receiving antenna. However, if the receiving antenna is a log-periodic array, the specified distance shall be the distance between the closest periphery of the EUT and the front-to-back center of the array of elements.

Tests were made with the antenna positioned in both the horizontal and vertical polarization planes. The measurement was varied in height above the conducting ground plane to obtain the maximum signal strength. Though specified in the report, the measurement distance shall be 3 meters. At any measurement distance, the antenna height was varied from 1 meter to 4 meters. These height scans apply for both horizontal and vertical polarization, except that for vertical polarization the minimum height of the center of the antenna shall be increased so that the lowest point of the bottom of the antenna clears the ground surface by at least 25 cm.

| Frequency Range (MHz) | Peak Data (kHz) | Quasi-Peak Data (kHz) | Average Data (kHz) |
|---|-----------------|-----------------------|--------------------|
| 30 MHz to 1 GHz | 120 kHz | 120 kHz | N/A |
| 1 GHz to 11 GHz | 1MHz | N/A | 1MHz |
| | | | |
| Measurements were made using the bandwidths and detectors specified. The video filter was at least as wide as the IF bandwidth of the measuring receiver. | | | |

Table 4. Radiated Emissions – Measurement Bandwidth

Emissions Tests Calculations

In the case of indoor measurements, radiated emissions measurements are made by the manipulation of correction factors using TILE software. This is done automatically by the software during the final measurement process.

In both cases, the level of the Field Strength of the interfering signal is calculated by adding the Antenna Factor, Cable Factor and by subtracting the Amplifier Gain from the measured reading. The basic equation is as follows:

$$FS = RA + AF + (CF - AG)$$

Where: FS = Field Strength

RA = Receiver (indicated) Amplitude

AF = Antenna Factor

CF = Cable Attenuation Factor

AG = Amplifier Gain

This laboratory uses an approach of combining the CF and AG using an end-to-end measurement of the entire cabling system, including the test cable, any in-line amplifiers, attenuators, or transient protection networks, all measured in-situ.

For a sample calculation, assume a receiver reading of 52.5 dBuV is obtained. With an antenna factor of 7.4 and a combined cable factor (CF + AG) of -27.9:

$$FS = 52.5 + 7.4 + (-27.9) = 32 \text{ dBuV/m}$$

$$FS = 32 \text{ dBuV/m}$$

If desired, this can be converted into its corresponding level in uV/m:

$$FS = 10^{((32 \text{ dBuV/m})/20)} = 39.8 \text{ uV/m}$$

Test Setup:

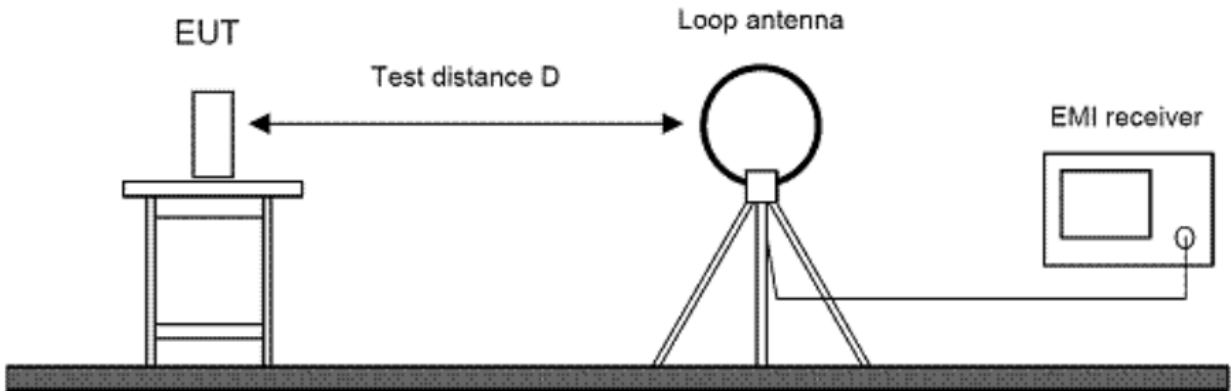

Figure 1. Radiated Emissions Test Setup (9kHz - 30MHz)

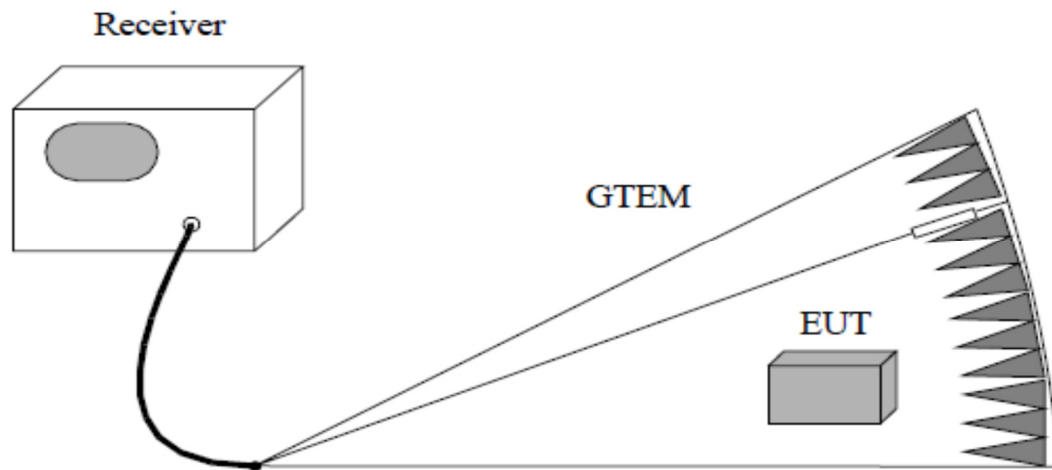
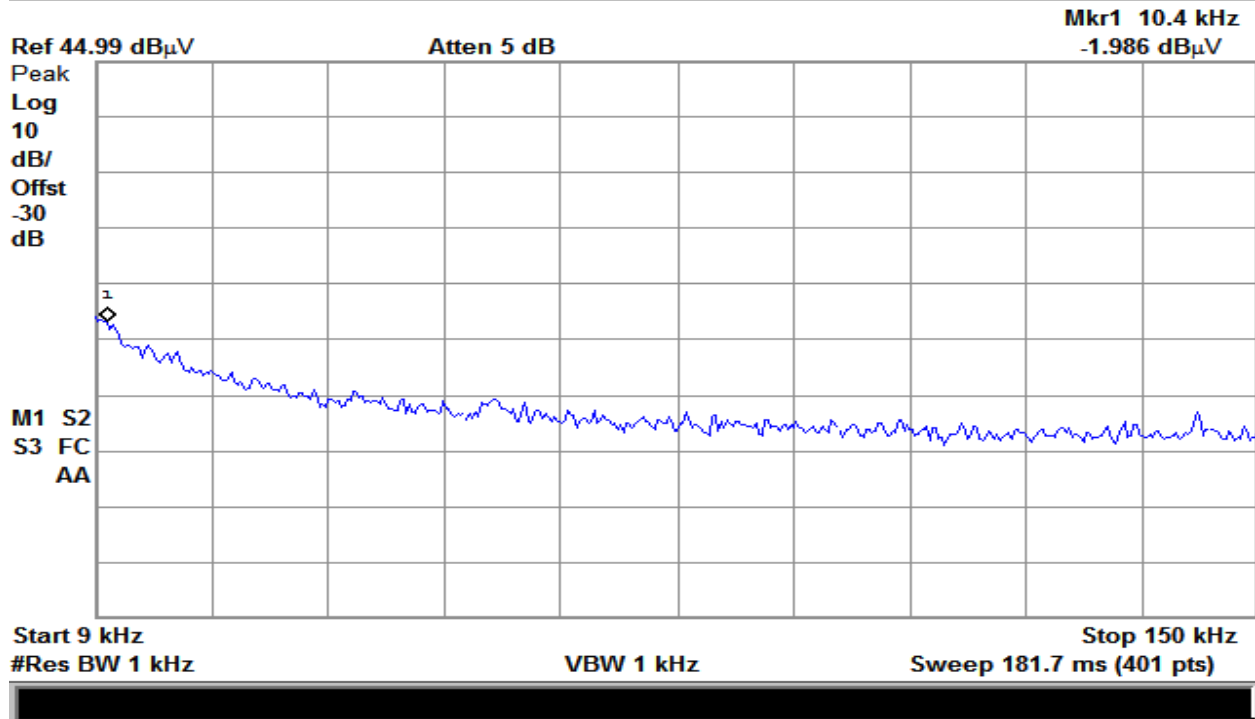
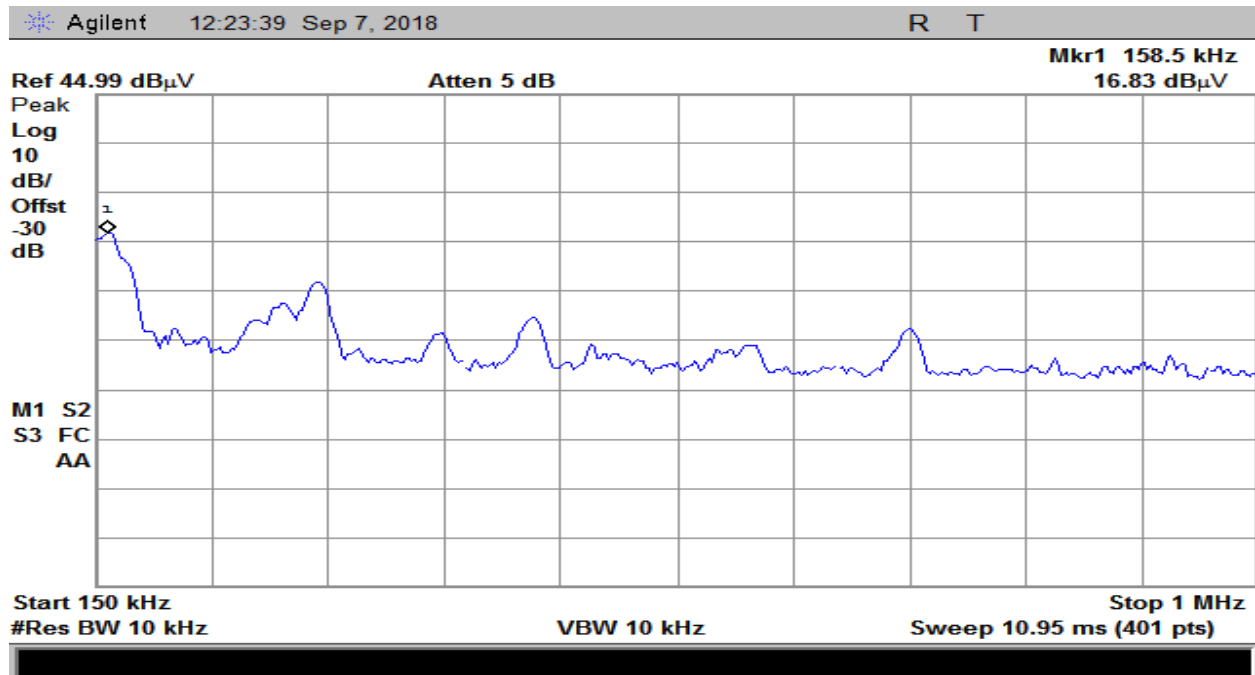

Figure 2. Radiated Emissions Test Setup (30MHz – 1GHz)



Plot 1 – Radiated Emissions – 9kHz to 150kHz



Plot 2 – Radiated Emissions – 150kHz to 1MHz

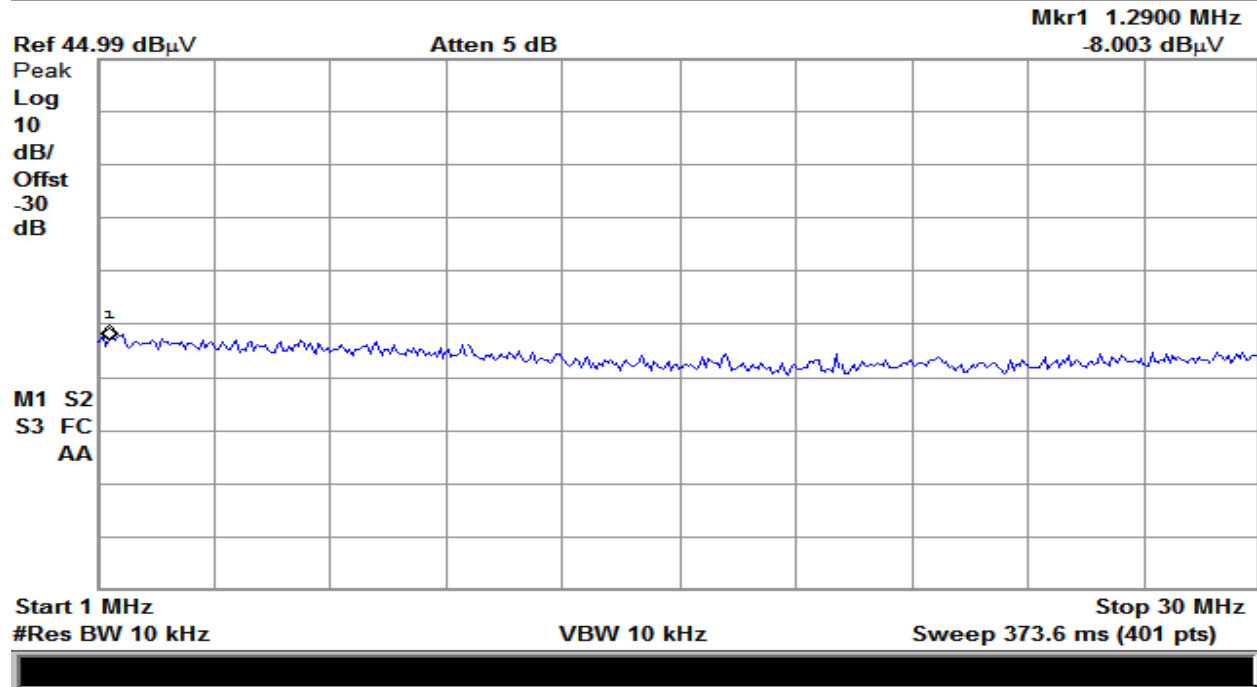

Plot 2 – Radiated Emissions – 1MHz to 30MHz

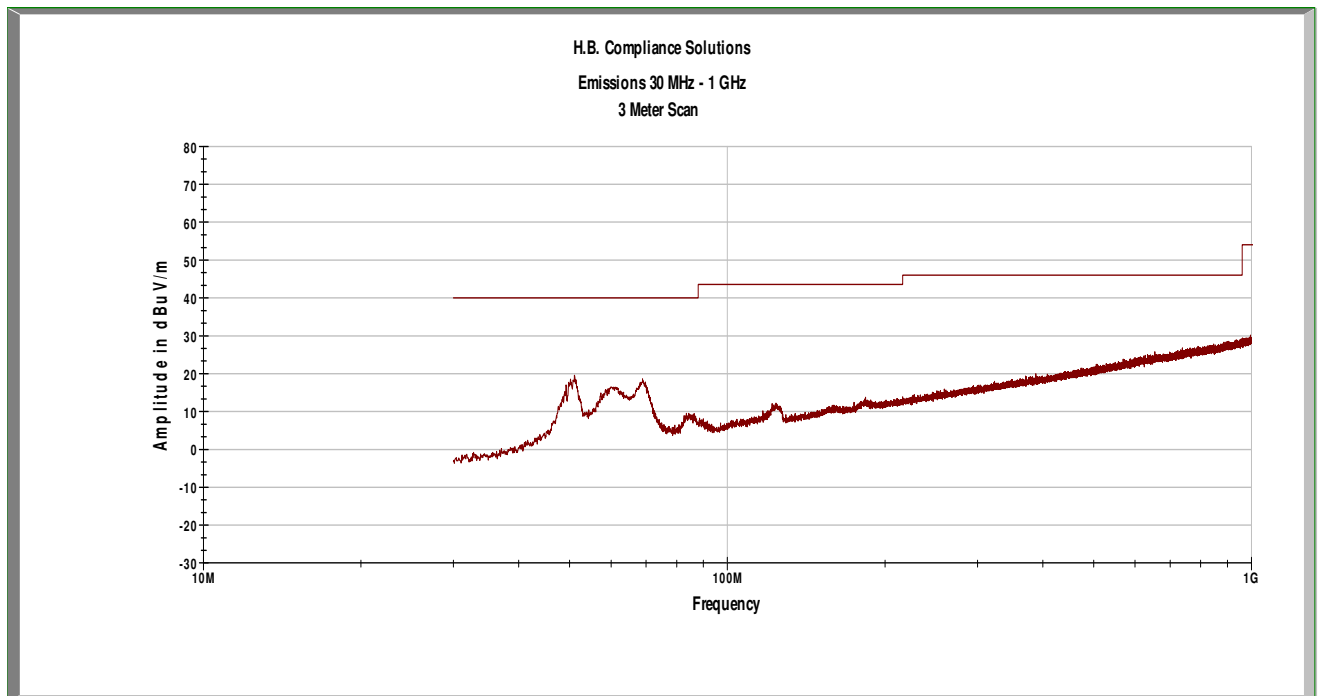

Plot 3 – Radiated Emissions – 30MHz to 1GHz

| Frequency (MHz) | Measured Level (dBuV/m) | Measurement Detector | Limit (dBuV) | Margin (dB) |
|-----------------|-------------------------|----------------------|--------------|-------------|
| 51.0 | 19.5 | Peak | 40.0 | -20.5 |
| 69.8 | 17.8 | Peak | 40.0 | -22.2 |

Table 8. Final Measurement Results for Radiated Emissions

Note: All digital emissions were 20dB below the test limit.

Criteria for Intentional Radiators

2. Conducted Emissions

| | | | |
|-----------------------------|---------|--------------------------|-------------|
| Test Requirement(s): | §15.207 | Test Engineer(s): | Jerry Mejak |
| Test Results: | Pass | Test Date(s): | 06/13/2018 |

Test Procedures: The EUT was placed on a non-metallic table, 80cm above the ground plane inside a shielded enclosure. The EUT was powered through a 50Ω/50μH LISN. The conducted emissions tests were performed using the mode of operation and configuration noted within this report. The frequency range investigated (scanned), is also noted in this report. Conducted power line measurements are made, unless otherwise specified, over the frequency range from 150 kHz to 30 MHz to determine the line-to-ground radio-noise voltage that is conducted from the EUT power-input terminals that are directly (or indirectly via separate transformer or power supplies) connected to a public power network. Equipment is tested with power cords that are the same as those cords normally used or that have electrical or shielding characteristics that are the same as those cords normally used. Typically, those measurements are made using a LISN (Line Impedance Stabilization Network). All 50 Ohm measuring ports of the LISN are terminated by 50 Ohms, either by the 50 Ohm EMI receiver or a 50 Ohm resistive load.

Refer to the Emissions Tests Calculations section in the Radiated Emissions section for sample calculations. For the purposes of the conducted emissions test, the Antenna Factor (AF) is replaced by the LISN correction factor.

| Frequency Range (MHz) | Peak Data (kHz) | Quasi-Peak Data (kHz) | Average Data (kHz) |
|--|-----------------|-----------------------|--------------------|
| 0.150 - 30 | 9.0 | 9.0 | 9.0 |
| Measurements were made using the bandwidths and detectors specified. No video filter was used. | | | |

Table 6. Conducted Emissions – Measurement Bandwidth

| Frequency Range (MHz) | 15.107(b), Class A Limits (dBuV) | | 15.107(a), Class B Limits (dBuV) | |
|-----------------------|----------------------------------|---------|----------------------------------|---------|
| | Quasi-Peak | Average | Quasi Peak | Average |
| 0.15 – 0.5 | 79 | 66 | 66 - 56 | 56 - 46 |
| 0.5 – 5.0 | 73 | 60 | 56 | 46 |
| 5.0 – 30 | 73 | 60 | 60 | 50 |

Note 1 – The lower limit shall apply at the transition frequencies.

Table 7. Conducted Emissions Limits – FCC Limits from Section 15.107(a)(b)

Test Setup:

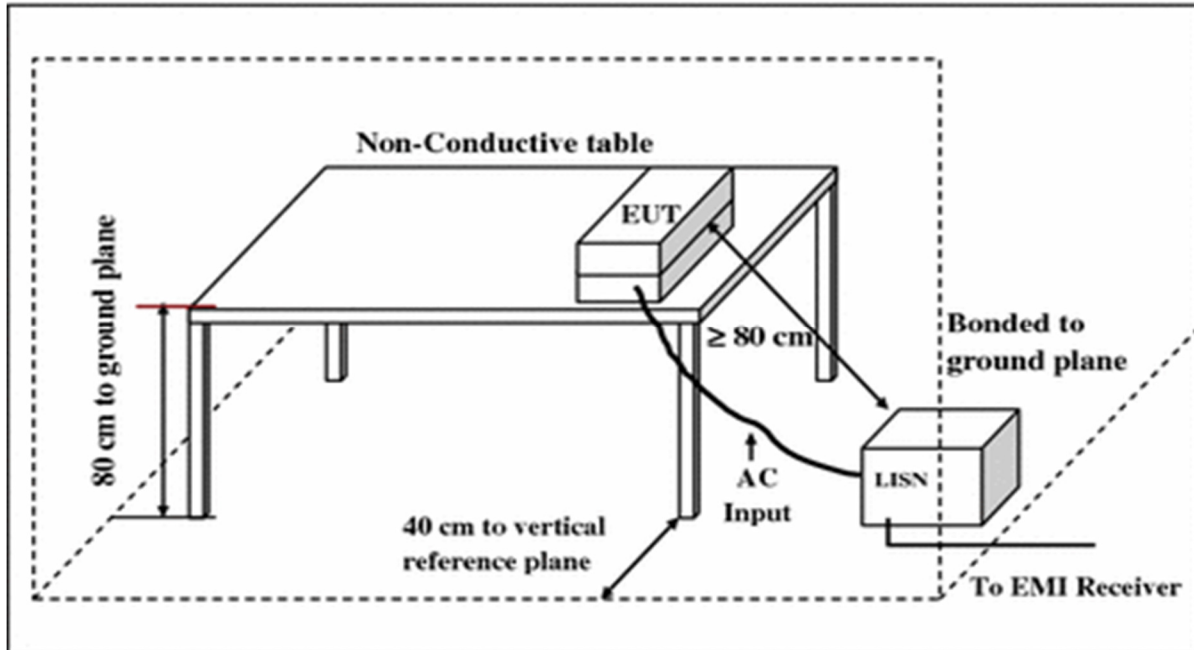
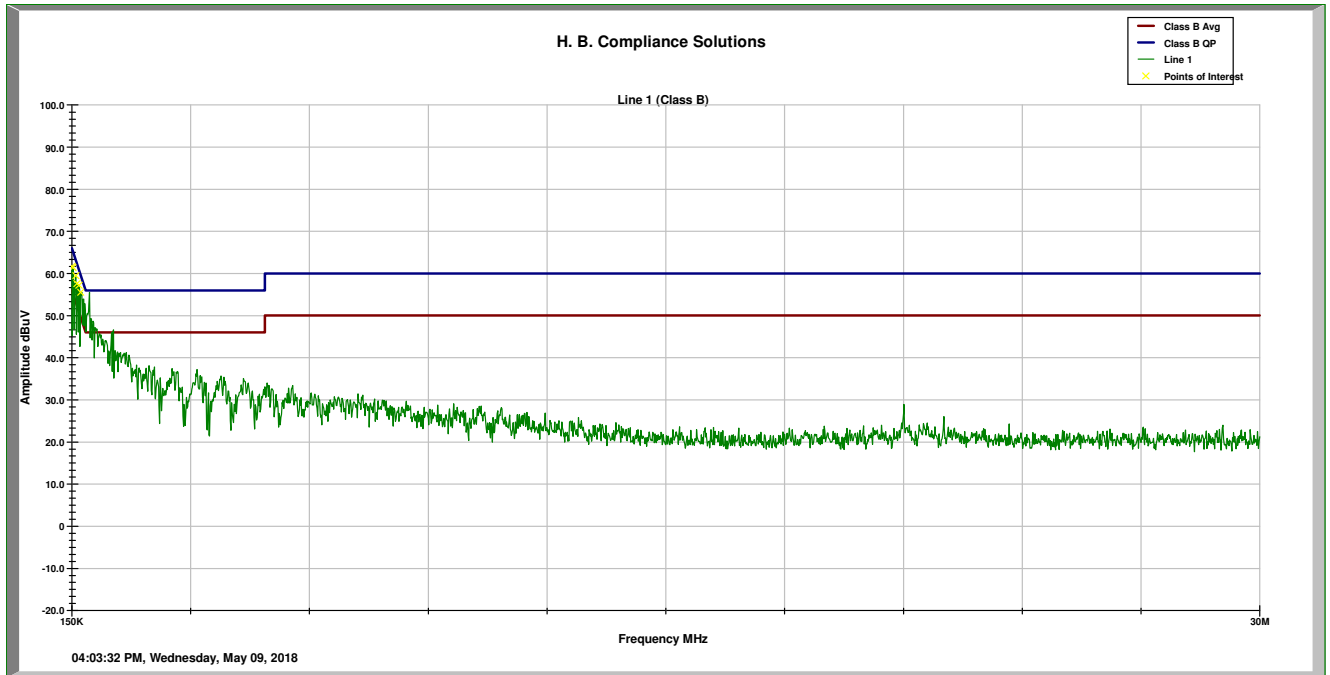

Figure 3. Conducted Emissions Test Setup



Plot 4 – Conducted Emission Plot – Line Side (Class B)

| Frequency (MHz) | Measured Level (dBuV) | Limit (dBuV) | Margin (dB) |
|-----------------|-----------------------|--------------|-------------|
| 0.161 | 57.42 | 65.66 | -8.24 |
| 0.181 | 57.88 | 65.089 | -7.20 |
| 0.256 | 57.17 | 62.94 | -5.77 |
| 0.269 | 56.91 | 62.57 | -5.66 |
| 0.316 | 55.51 | 61.23 | -5.72 |
| 0.360 | 54.14 | 59.99 | -5.85 |

Table 3. Measurement Results for QP

| Frequency (MHz) | Measured Level (dBuV) | Limit (dBuV) | Margin (dB) |
|-----------------|-----------------------|--------------|-------------|
| 0.161 | 41.115 | 55.66 | -14.54 |
| 0.181 | 38.487 | 55.08 | -16.60 |
| 0.256 | 39.707 | 52.94 | -13.24 |
| 0.269 | 40.263 | 52.57 | -12.31 |
| 0.316 | 38.762 | 51.23 | -12.46 |
| 0.360 | 37.955 | 49.99 | -12.04 |

Table 4. Measurement Results for Average

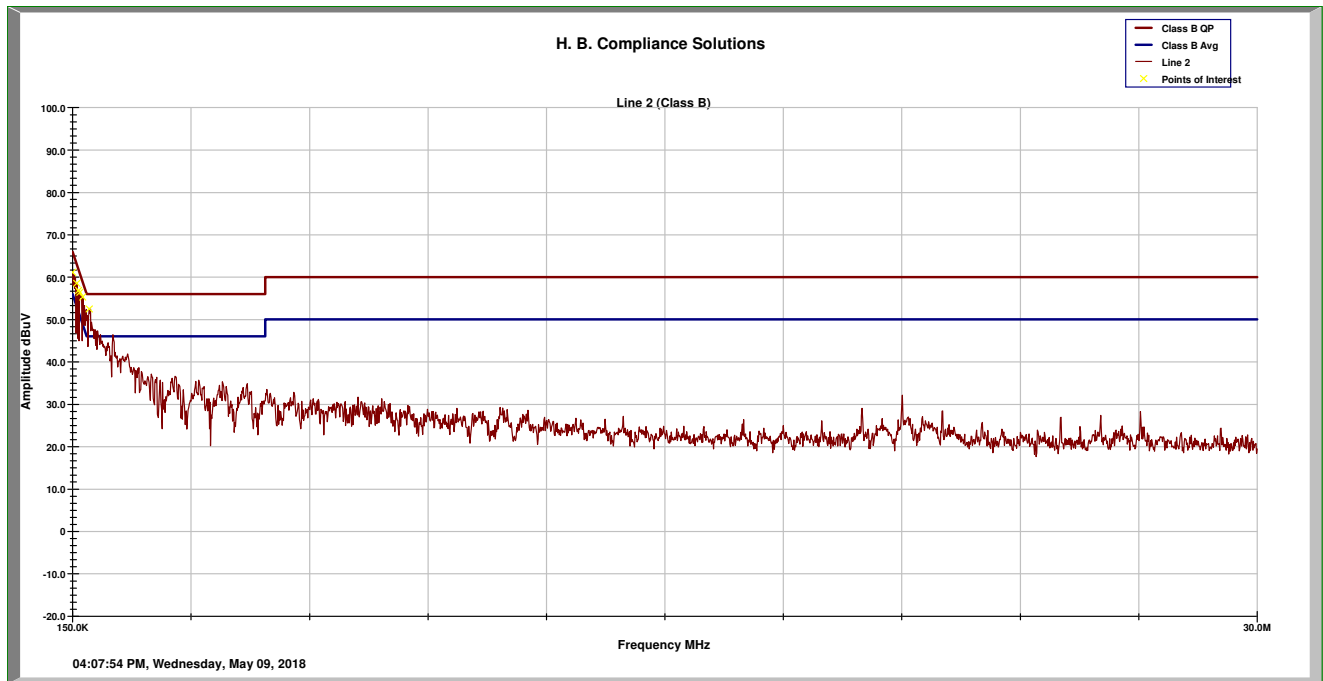

Plot 5 – Conducted Emissions – Neutral Side (Class B)

| Frequency (MHz) | Measured Level (dBuV) | Limit (dBuV) | Margin (dB) |
|-----------------|-----------------------|--------------|-------------|
| 0.155 | 59.23 | 65.84 | -6.61 |
| 0.240 | 57.31 | 63.42 | -6.11 |
| 0.287 | 55.57 | 62.07 | -6.50 |
| 0.332 | 54.78 | 60.78 | -6.00 |
| 0.388 | 53.16 | 59.18 | -6.02 |
| 0.552 | 48.58 | 56 | -7.42 |

Table 5. Measurement Results for QP

| Frequency (MHz) | Measured Level (dBuV) | Limit (dBuV) | Margin (dB) |
|-----------------|-----------------------|--------------|-------------|
| 0.155 | 38.388 | 55.842 | -17.454 |
| 0.240 | 39.917 | 53.425 | -13.507 |
| 0.287 | 39.375 | 52.079 | -12.704 |
| 0.332 | 38.54 | 50.789 | -12.249 |
| 0.388 | 38.32 | 49.183 | -10.863 |
| 0.552 | 41.07 | 46 | -4.93 |

Table 6. Measurement Results for Average

2. Occupied Bandwidth

| | | | |
|-----------------------------|-----------|--------------------------|-----------|
| Test Requirement(s): | 15.215(c) | Test Engineer(s): | Hoosam B. |
| Test Results: | Pass | Test Date(s): | 06/18/18 |

Test Procedure: As required by 47 CFR 15.215(c): The bandwidth of the emission shall be determined at the points 20dB down from the modulated carrier.

Customer provided a test mode internal to the EUT to control the RF modulation. The EUT antenna was attached and the waveform was received by the test antenna which was connected to the spectrum analyzer. The measured highest peak power was set relative to zero dB reference. The RBW of the Spectrum Analyzer was set to 300Hz and VBW>RBW.

| Frequency (kHz) | 20dB Bandwidth (kHz) | 99% Bandwidth (kHz) |
|-----------------|----------------------|---------------------|
| 156.8 | 5.0 | 4.69 |

Table 8. Occupied Bandwidth Summary, Test Results

Test Setup:

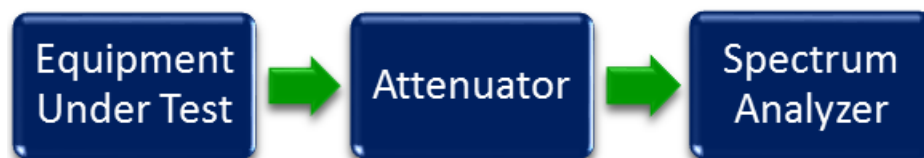
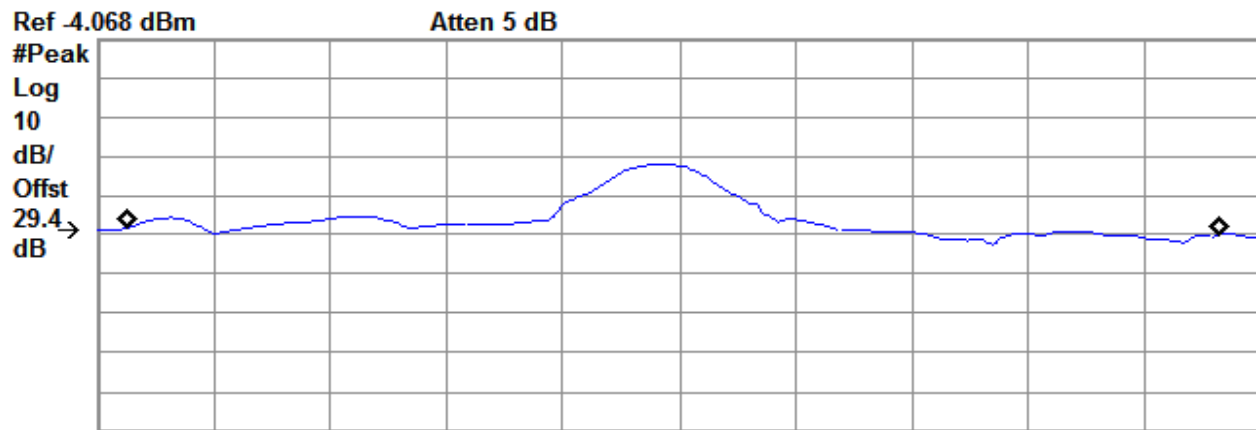

Figure 4. Occupied Bandwidth Test Setup

The following pages show measurements of Occupied Bandwidth plot:



Center 156.8 kHz Span 5 kHz
#Res BW 300 Hz #VBW 300 kHz Sweep 342 ms (401 pts)

Occupied Bandwidth
4.6992 kHz

Occ BW % Pwr 99.00 %
x dB -20.00 dB

Transmit Freq Error -26.553 Hz
x dB Bandwidth 5.000 kHz

Plot 6 – 20dB BW & 99% Occupied BW (For IC Only)

5. Radiated Emissions

| | | | |
|-----------------------------|---------|--------------------------|------------|
| Test Requirement(s): | §15.209 | Test Engineer(s): | Jerry M. |
| Test Results: | Pass | Test Date(s): | 06/13/2018 |

Test Procedures: As required by 47 CFR 15.209, Radiated emission measurements were made in accordance with the procedures of the ANSI C63.4 - 2014.

The EUT was placed on a wooden table inside a GTEM chamber. The EUT was set on continuous transmit.

The measurement distance was set at 3 meters from the EUT. During the tests, EUT azimuth were varied in order to identify the maximum level of emissions from the EUT. The frequency range up to the 10th harmonic was investigated.

| Frequency Range | Detector Setting | Resolution Bandwidth | Video Bandwidth | Span |
|------------------|------------------|----------------------|---------------------------|--------------|
| 30MHz – 1000 MHz | Quasi Peak | 120kHz | As Specified in §15.35(c) | Zero |
| 1000 MHz – 5GHz | Peak | 1MHz | 1MHz | As necessary |
| 1000 MHz – 5GHz | Average | 1MHz | As Specified in §15.35(c) | As necessary |

Table 12 - Analyzer Settings

Test Procedures:

1. Turn on the EUT and allow it to warm up for 15 minutes.

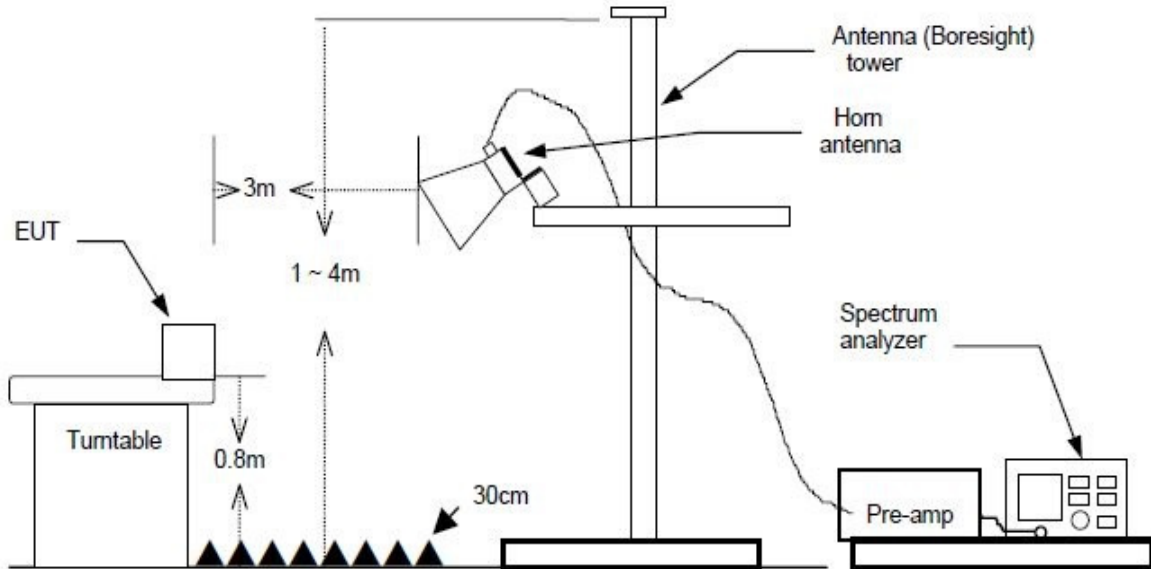

Figure 5. Radiated Emission Above 1GHz Test Setup

The following table shows the highest levels of radiated emissions on both polarizations of horizontal and vertical

| Frequency (MHz) | Peak Measurement @ 3m (dBuV/m) | Quasi-Peak Amp. (dBuV/m) | FCC Quasi-Peak Limit (dBuV/m) | FCC Peak Limit (dBuV/m) | Quasi-Peak Margin (dB) | Peak Margin (dB) | Comment |
|-----------------|--------------------------------|--------------------------|-------------------------------|-------------------------|------------------------|------------------|-------------|
| 0.156 | 31.29 | 31.29 | 105.7 | 125.7 | -74.41 | -94.4 | Fundamental |

Table 13 – Fundamental Field Strength

| Frequency (MHz) | Peak Measurement @ 3m (dBuV/m) | Quasi-Peak Amp. (dBuV/m) | FCC Quasi-Peak Limit (dBuV/m) | FCC Peak Limit (dBuV/m) | Quasi-Peak Margin (dB) | Peak Margin (dB) | Comment |
|-----------------|--------------------------------|--------------------------|-------------------------------|-------------------------|------------------------|------------------|---------|
| 51.0 | 19.5 | N/A | 40.0 | 60.0 | -20.6 | -40.5 | |
| 69.8 | 17.8 | N/A | 40.0 | 60.0 | -22.2 | -42.2 | |

Table 13 - Radiated Spurious Emission Data

Remark:

To get a maximum emission level from the EUT, the EUT was moved throughout the X-axis, Y-axis and Z-Axis. Worst case is X-axis.

Test Equipment

| Equipment | Manufacturer | Model | Serial # | Last Cal Date | Cal Due Date |
|-------------------|---------------------|-------------|------------|---------------|--------------|
| Power Supply | Hewlett Packard | E3610A | KR83021468 | NCR | None |
| LISN | Laplace Instruments | LISN 1600 | 152946 | Mar-14-18 | Mar-14-19 |
| Spectrum Analyzer | Hewlett Packard | 8595EM | 3801A00177 | Mar-15-18 | Mar-15-19 |
| DMM | Fluke | 77 III | 72550270 | Jan/30/18 | Jan/30/20 |
| Combiner/Splitter | Mini-Circuits | ZFSC-2-2 | None | NCR | None |
| High Pass Filter | Mini-Circuits | VHF-3100+ | 15542 | NCR | None |
| 6dB Attenuator | Bird | 75-A-MFN-06 | 0641 | NCR | N/A |
| EMI Receiver | Hewlett Packard | 8568B | 2314A02642 | 11-Jul-17 | 11-Aug-18 |
| Signal Generator | Agilent | E4432B | US40053021 | NCR | N/A |
| Attenuator 20dB | Mini Circuits | CAT-20 | 10012 | NCR | None |
| Loop Antenna | Electro-Metrics | ALR 25 | 443 | Jan/30/18 | Jan/30/19 |
| Antenna | EMCO | GTEM 5417 | 1063 | Verified | N/A |

Table 14 – Test Equipment List

***Statement of Traceability:** Test equipment is maintained and calibrated on a regular basis. All calibrations have been performed by a 17025 accredited test facility, traceable to National Institute of Standards and Technology (NIST)

6. Measurement Uncertainty

ISO/IEC 17025 requires that an estimate of the measurement uncertainties associated with the emissions test results be included in the report. The following measurement uncertainty values have been calculated as show in the table below:

| Measured Parameter | Measurement Unit | Frequency Range | Expanded Uncertainty |
|--------------------------------|------------------|-----------------|----------------------|
| Conducted Emissions (AC Power) | dBuV or dBuA | 150kHz – 30MHz | ± 4.3dB |
| Radiated Emission below 30MHz | dBuV/m | 9kHz-30MHz | ± 2.96dB |
| Radiated Emissions below 1GHz | dBuV/m | 30 – 1000MHz | ± 5.6dB |
| Radiated Emissions above 1GHz | dBuV/m | 1 – 26.5GHz | ± 4.1dB |

The reported expanded uncertainty has been estimated at a 95% confidence level (k=2)

END OF TEST REPORT