

proxy

User Manual and Installation Guide

Proxy Mobile Reader Pro Wallbox

www.proxy.com | support@proxy.com

Last updated: March 25, 2019



Table of Contents

Introduction	5
Reader	5
Functionality	5
Mobile Reader Pro Wallbox Main Housing	6
Mobile Reader Pro Wallbox Wall Plate	6
Product Details	7
RF Exposure Information	7
Reader Specifications	8
Rated current at different operating voltages for PRXY-WW-1.0 & PRXY-WK-1.0	8
Installation Details	9
Parts List	9
Recommended Infrastructure	9
Wiring Information	10
Cable Color codes for Pig Tail Reader	10
Caution:	10
Mounting the Mobile Reader Pro	11
Location of mounting holes on wall:	11
Reader Installation Steps	11
Power Up and Testing	12
Certifications	13
FCC	13
Tune up power table BLE / WLAN	13
RF Exposure Information	14
Information to user	14
IC	14
RF Exposure Information	15
Informations d'exposition RF	15

CE	15
Tune up power table BLE / WLAN	15
Waste Electrical and Electronic Equipment (WEEE)	16
UL294	16
UL 294 Access Control Performance Levels	16



Introduction

This document details the Proxy Mobile Reader Pro and its basic operational and installation procedures. It covers the details of the Wallbox form-factor reader.

Model: Standard Wallbox PRXY-WW-1.0 (white version) , PRXY-WK-1.0 (black version)

The reader comes in one variant for interfacing with the control panel.

- Standard HF LF BLE IEEE 802.11b/g/n

The reader comes in one variant in functionality.

- Standard HF LF BLE IEEE 802.11b/g/n

Reader

Functionality

Mobile Reader Pro is a physical access control wireless mobile credential and smart card reader that can read HF / LF contactless credentials conforming to the following standards: ISO 14443 A & B as well as wireless credentials over BLE. The reader can interface with an access control system equipped with a Wiegand or RS485 serial interface. The reader consists of the following main parts.

Mobile Reader Pro Wallbox Main Housing

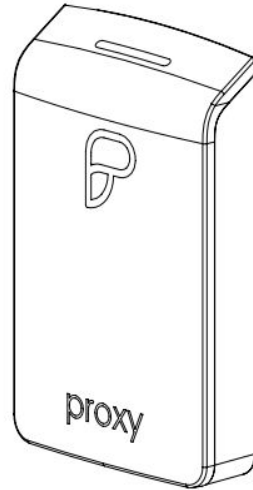

Mobile Reader Pro Wallbox Wall Plate

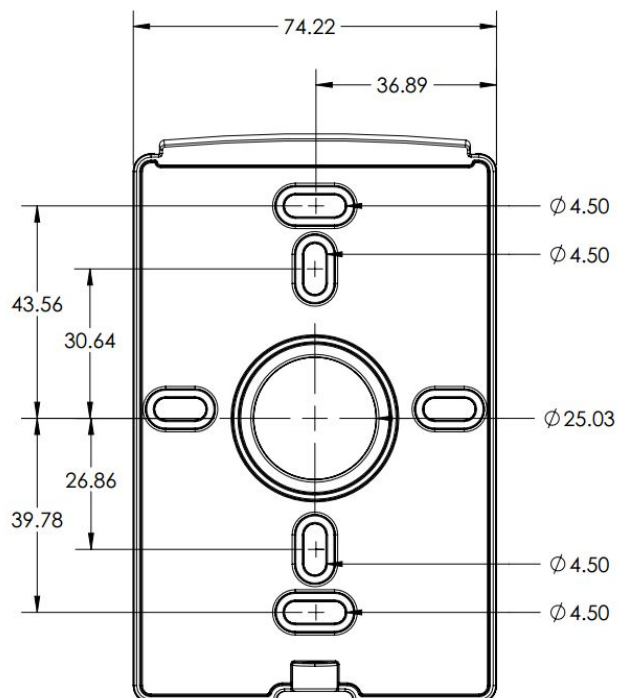

Product Details

Model Name:	Standard Wallbox / PRXY-WW-1.0 / PRXY-WK-1.0
Device Type:	RFID reader, 13.56MHz (HF) / 125 KHz (LF) / Mobile Credential: 2.4GHz (BLE) Physical Access control Reader (accessory equipment)
Type of Equipment:	Sealed Reader Suitable for Indoor use and Outdoor use – PRXY-MW-1.0 and PRXY-MK-1.0
Interface Type:	Pigtail Cable (11 Core + Drain)
Electrical Rating:	6V - 16V DC, 0.5A, 8W (Max)
Communication Protocol:	Wiegand, RS485 (2wire - Half Duplex), BLE, IEEE 802.11b/g/n
Credential Type:	125kHz proximity cards: - HID® Proximity, Indala®, CasiRusco®, AWID, Farpointe®, Others 13.56MHz smart cards: - uTrust, PIV, PIV-I, CAC, TWIC, - MIFARE Classic, DESFire EV1, PLAID [AS 5185-2010], - ISO15693 UID, ISO14443A/B UID, - HID® iClass Card Serial Number (CSN) BLE: Any bit format (standard or custom) up to 120 bits
Transmission Technology:	Wiegand, OSDP, OSDP2

* Communication via Wiegand was evaluated by UL and serves as the interface between the reader and panel. Communication via RS485, OSDP or Ethernet was not evaluated by UL.

*IEEE802.11b/g/n communications are used for non-critical operations (OTA, backhaul, etc.).

RF Exposure Information

This device has been tested and meets applicable limits for Radio Frequency (RF) exposure. This equipment should be installed and operated with minimum distance 20 cm between the radiator & your body.

Reader Specifications

<u>Model</u>	<u>Operating Voltage</u>	<u>Current Rating</u>	<u>Operating Temperature</u>
PRXY-WW-1.0 // PRXY-WK-1.0 HF LF BLE IEEE 802.11b	6V - 16V DC	0.5A	-35C to +66C, 85% RH

There shall be no connections made to the RS-485 interface (RS485+ and RS485-) for UL installations.

Note:

- Standby Power is not provided by the Card Readers. The Standby Power Level is dependent on the external power source connected to the Card Reader.
- For RS485 use 24 AWG twisted pair cable with a shunt capacitance of 16 pF per foot and 100-ohm characteristic impedance (option: Category 5 shielded twisted pair (STP)).

Rated current at different operating voltages for PRXY-WW-1.0 & PRXY-WK-1.0

- All wiring or cables to the Card Readers shall be the shielded type.

<u>Voltage (V)</u>	<u>Average Current (mA)</u>	<u>Peak Current (mA)</u>
6	180	260
8	162	248
10	126	200
12	102	165
14	95	135
16	80	125

Installation Details

Wiring methods shall be in accordance with the National Electrical Code (ANSI/NFPA70), local codes, and the authorities having jurisdiction.

Parts List

- Mobile Reader Pro - 1
- Security Screw - #6 - 32 x 3/8" -- 1 Nos
- Mounting Screws - #6-32 x 1" -- 2 Nos
- Nylon anchor plugs - #6 Size x 1" -- 2 Nos



Recommended Infrastructure

- All cabling and wiring shall be UL Listed and/or UL Recognized.
- All readers shall be powered by UL listed power-limited power supply, or power-limited output from UL listed control panel.
- There shall be no connections made to the RS-485 interface (RS485+ and RS485-) for UL installations.
- Cable Wiegand - 22AWG Shielded cable. (Cable P No: ALPHA WIRE, P/N 1299/10C)
- Cable RS485 - RS485 for 1000m** (4000 ft) 24AWG STP
- Linear DC PS
- 6 - 16 V, 1A min.

** Tested in lab conditions up to 115Kbaud

Wiring Information

Cable Color codes for Pig Tail Reader

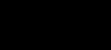
Red	+VDC 12V (nominal)	
Black & White	Ground	
Green	Wiegand Data 0	
White	Wiegand Data 1	
Orange	Green LED	
Yellow	Buzzer	
Blue	Hold	
Brown	Red LED	
Grey	RS485 -	
Pink	RS485 +	
Violet	Tamper Output	
Black / Drain	Shield Ground	

** For Wiring diagrams and termination points please see your control panel user manual. Installations will differ between access control panel manufacturers.

Caution:

During wiring, make sure that the +VDC lines does not make contact with any other cables, as it might affect reader functionality/ cause damage to the reader.

Mounting the Mobile Reader Pro

Location of mounting holes on wall:

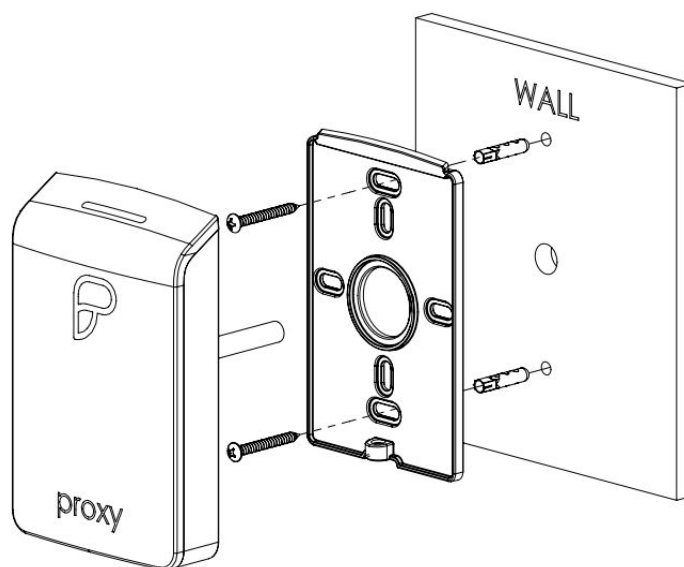

Reader Installation Steps

- Make two holes on the wall as per the image above corresponding to the type of reader.
- Insert the nylon screw plugs into the wall.
- Connect the wires as per the Table in Section 5.3.1.
- Mobile Reader Pro Wallbox Wall Plate is to be secured onto the wall using the Screws (A).
- Mobile Reader Pro Wallbox Main Housing can be installed onto Wall Plate.
- Secure the Main Housing to the wall plate using Security Screw (B).

Power Up and Testing

1. Turn power on.
 - Indicator Light (top of housing) powers on and turns RED.
 - Branding LEDs turn on (Proxy Logo Displayed).
2. Present a card.
 - Access Granted: The Indicator LED blinks green, and a short beep is emitted.
 - Access Denied: This is dependent on Access controller configuration.
3. Present a Phone with Proxy ID App Enabled.
 - Access Granted: The Indicator LED blinks green, and a short beep is emitted.
 - Access Denied: This is dependent on Access controller configuration.

This is the default reader behavior.

Certifications

FCC

Tune up power table BLE / WLAN

- Each product is programmed with the pre-defined RF parameters.
- Each product RF power level is measured to ensure the power level not exceeding the target power level, in a fully calibrated setup.
- These settings cannot be changed.

Please find below the **Maximum** Transmit Power for production units:

<For Type1LD>

Band / Mode	Average Power (dBm)
	LE
	GFSK
Bluetooth	7

Band / Channel / Frequency (MHz)	IEEE 802.11 Average Power (dBm)		
	11b	11g	HT20
2.4GHz WLAN	17	17	17

<For XRBH-1>

Band / Mode	Average Power (dBm)
	LE
	GFSK
Bluetooth	5

This equipment has been tested and found to comply with the limits for a Class B digital device, pursuant to part 15 of the FCC Rules. These limits are designed to provide reasonable protection against harmful interference in a residential installation. This equipment generates uses and can radiate radio frequency energy and, if not installed and used in accordance with the instructions, may cause harmful interference to radio communications. However, there is no guarantee that interference will not occur in a particular installation. If this equipment does cause harmful interference to radio or television reception, which can be determined by turning the equipment off and on, the user is encouraged to try to correct the interference by one or more of the following measures:

- Reorient or relocate the receiving antenna.
- Increase the separation between the equipment and receiver.
- Connect the equipment into an outlet on a circuit different from that to which the receiver is connected.
- Consult the dealer or an experienced radio/TV technician for help.

RF Exposure Information

This device has been tested and meets applicable limits for Radio Frequency (RF) exposure. This equipment should be installed and operated with minimum distance 20 cm between the radiator & your body.

Information to user

This device complies with part 15 of the FCC Rules. Operation is subject to the following two conditions: (1) This device may not cause harmful interference, and (2) this device must accept any interference received, including interference that may cause undesired operation.

Changes or modifications not expressly approved by Proxy, Inc. could void the user's authority to operate the equipment.

IC

This Class B digital apparatus complies with Canadian ICES-003.
This device complies with Industry Canada license-exempt RSS standard(s).

Operation is subject to the following two conditions:

- (1) This device may not cause interference
- (2) This device must accept any interference, including interference that may cause undesired operation of the device.

Le présent appareil est conforme aux CNR d'Industrie Canada applicables aux appareils radio exempts de licence. L'exploitation est autorisée aux deux conditions suivantes:

- (1) l'appareil ne doit pas produire de brouillage, et
- (2) l'utilisateur de l'appareil doit accepter tout brouillage radioélectrique subi, même si le brouillage est susceptible d'en compromettre le fonctionnement."

RF Exposure Information

This device has been tested and meets applicable limits for Radio Frequency (RF) exposure. This equipment should be installed and operated with minimum distance 20 cm between the radiator & your body.

Informations d'exposition RF

Cet appareil a été testé et répond aux limites applicables en matière d'exposition aux radiofréquences (RF).

Cet équipement doit être installé et utilisé avec une distance minimale de 20 cm entre le radiateur et votre corps.

CE

Tune up power table BLE / WLAN

Each product is programmed with the pre-defined RF parameters.

Each product RF power level is measured to ensure the power level not exceeding the target power level, in a fully calibrated setup.

These settings cannot be changed.

Please find below the **Maximum** Transmit Power for production units:

<For Type1LD>

Band / Mode	Average Power (dBm)
	LE
	GFSK
Bluetooth	8.2

Band / Channel / Frequency (MHz)	IEEE 802.11 Average Power (dBm)		
	11b	11g	HT20
2.4GHz WLAN	9.3	9.3	9.1

<For XRBH-1>

Band / Mode	Average Power (dBm)
	LE
	GFSK
Bluetooth	1.0

Hereby, Proxy, Inc. declares that the radio equipment type Mobile Reader Pro is in compliance with Directive 2014/53/EU.

Please scan the barcode on the label to view the user guide.



Waste Electrical and Electronic Equipment (WEEE)

This symbol means that according to local laws and regulations your product and/or its battery shall be disposed of separately from household waste. When this product reaches its end of life, take it to a collection point designated by local authorities. Proper recycling of your product will protect human health and the environment.

Waste Electrical and Electronic Equipment (WEEE)

This symbol means that according to local laws and regulations your product and/or its battery shall be disposed of separately from household waste. When this product reaches its end of life, take it to a collection point designated by local authorities. Proper recycling of your product will protect human health and the environment.

UL294

Communication via Wiegand was evaluated by UL and serves as the interface between the reader and panel

Communication via RS485 or OSDP is not permitted.

All terminals are Power Limited / Class 2 circuits.

UL 294 Access Control Performance Levels

- Destructive Attack: Level I
- Line Security: Level I
- Endurance: Level I
- Standby Power: Level I