



FCC RADIO TEST REPORT

FCC ID : 2AP67-5926
Equipment : Digital Media Receiver
Model Name : K9Y29E
Applicant : Onaka LLC
1915 NE Stucki Ave., Ste 400
Beaverton, OR 97006
Standard : FCC Part 15 Subpart C §15.247

The test was completed on Oct. 22, 2018. We, SPORTON INTERNATIONAL INC., would like to declare that the tested sample has been evaluated in accordance with the test procedures and has been in compliance with the applicable technical standards.

The report must not be used by the client to claim product certification, approval, or endorsement by TAF or any agency of government.

The test results in this report apply exclusively to the tested model / sample. Without written approval of SPORTON INTERNATIONAL INC. EMC & Wireless Communications Laboratory, the test report shall not be reproduced except in full.

Approved by: Joseph Lin

SPORTON INTERNATIONAL INC. EMC & Wireless Communications Laboratory
No. 52, Huaya 1st Rd., Guishan Dist., Taoyuan City, Taiwan (R.O.C.)



Table of Contents

History of this test report..... 3

Summary of Test Result..... 4

1 General Description 5

 1.1 Product Feature of Equipment Under Test..... 5

 1.2 Product Specification of Equipment Under Test..... 6

 1.3 Modification of EUT 6

 1.4 Testing Location 7

 1.5 Applicable Standards..... 7

2 Test Configuration of Equipment Under Test 8

 2.1 Carrier Frequency and Channel 8

 2.2 Test Mode..... 9

 2.3 Connection Diagram of Test System..... 10

 2.4 Support Unit used in test configuration and system 11

 2.5 EUT Operation Test Setup 11

 2.6 Measurement Results Explanation Example..... 11

3 Test Result 12

 3.1 6dB and 99% Bandwidth Measurement 12

 3.2 Output Power Measurement..... 14

 3.3 Power Spectral Density Measurement 15

 3.4 Conducted Band Edges and Spurious Emission Measurement 18

 3.5 Radiated Band Edges and Spurious Emission Measurement 79

 3.6 AC Conducted Emission Measurement..... 83

 3.7 Antenna Requirements 85

4 List of Measuring Equipment..... 86

5 Uncertainty of Evaluation 88

Appendix A. Conducted Test Results

Appendix B. AC Conducted Emission Test Result

Appendix C. Radiated Spurious Emission

Appendix D. Radiated Spurious Emission Plots

Appendix E. Duty Cycle Plots



Summary of Test Result

Report Clause	Ref Std. Clause	Test Items	Result (PASS/FAIL)
3.1	15.247(a)(2)	6dB Bandwidth	Pass
3.1	2.1049	99% Occupied Bandwidth	Reporting only
3.2	15.247(b)	Power Output Measurement	Pass
3.3	15.247(e)	Power Spectral Density	Pass
3.4	15.247(d)	Conducted Band Edges	Pass
		Conducted Spurious Emission	Pass
3.5	15.247(d)	Radiated Band Edges and Radiated Spurious Emission	Pass
3.6	15.207	AC Conducted Emission	Pass
3.7	15.203 & 15.247(b)	Antenna Requirement	Pass

Reviewed by: Wii Chang

Report Producer: Polly Tsai



1 General Description

1.1 Product Feature of Equipment Under Test

Product Feature	
Equipment	Digital Media Receiver
Model Name	K9Y29E
FCC ID	2AP67-5926
EUT supports Radios application	WLAN 11b/g/n HT20 WLAN 11a/n HT20/HT40 WLAN 11ac VHT20/VHT40/VHT80 Bluetooth BR/EDR/LE

1.2 Product Specification of Equipment Under Test

Standards-related Product Specification										
Tx/Rx Channel Frequency Range	2412 MHz ~ 2472 MHz									
Maximum (Peak) Output Power to antenna	<p><Ant. 1> 802.11b : 23.02 dBm (0.2004 W) 802.11g : 25.08 dBm (0.3221 W) 802.11n HT20 : 25.11 dBm (0.3243 W)</p> <p><Ant. 2> 802.11b : 24.47 dBm (0.2799 W) 802.11g : 25.67 dBm (0.3690 W) 802.11n HT20 : 25.68 dBm (0.3698 W)</p> <p>MIMO<Ant. 1+2> 802.11b : 26.36 dBm (0.4325 W) 802.11g : 28.17 dBm (0.6561 W) 802.11n HT20 : 28.34 dBm (0.6823 W)</p>									
99% Occupied Bandwidth	<p><Ant. 1> 802.11b : 14.05 MHz 802.11g : 16.90 MHz 802.11n HT20 : 17.95 MHz</p> <p><Ant. 2> 802.11b : 14.05 MHz 802.11g : 17.20 MHz 802.11n HT20 : 17.85 MHz</p> <p>MIMO<Ant. 1> 802.11b : 14.20 MHz 802.11g : 17.05 MHz 802.11n HT20 : 18.00 MHz</p> <p>MIMO<Ant. 2> 802.11b : 13.85 MHz 802.11g : 16.80 MHz 802.11n HT20 : 17.75 MHz</p>									
Antenna Type / Gain	Ant. 1 : PCB Printed Inverted-F Antenna type with gain 1.28 dBi Ant. 2 : FPC Inverted-F Antenna type with gain 1.41 dBi									
Type of Modulation	802.11b : DSSS (DBPSK / DQPSK / CCK) 802.11g/n : OFDM (BPSK / QPSK / 16QAM / 64QAM)									
Antenna Function for Transmitter	<table border="1"> <thead> <tr> <th></th> <th>Ant. 1</th> <th>Ant. 2</th> </tr> </thead> <tbody> <tr> <td>802.11 b/g/n</td> <td>V</td> <td>V</td> </tr> <tr> <td>802.11 b/g/n MIMO</td> <td>V</td> <td>V</td> </tr> </tbody> </table>		Ant. 1	Ant. 2	802.11 b/g/n	V	V	802.11 b/g/n MIMO	V	V
	Ant. 1	Ant. 2								
802.11 b/g/n	V	V								
802.11 b/g/n MIMO	V	V								

Note: MIMO Ant. 1+2 is a calculated result from sum of the power MIMO Ant. 1 and MIMO Ant. 2.

1.3 Modification of EUT

No modifications are made to the EUT during all test items.



1.4 Testing Location

Sporton Lab is accredited to ISO 17025 by Taiwan Accreditation Foundation (TAF code : 1190) and the FCC designation No. TW1190 and TW0007 under the FCC 2.948(e) by Mutual Recognition Agreement (MRA) in FCC Test.

Test Site	SPORTON INTERNATIONAL INC.	
Test Site Location	No.52, Huaya 1st Rd., Guishan Dist., Taoyuan City, Taiwan (R.O.C.) TEL: +886-3-327-3456 FAX: +886-3-328-4978	
Test Site No.	Sporton Site No.	
	TH05-HY	CO05-HY

Note: The test site complies with ANSI C63.4 2014 requirement.

Test Site	SPORTON INTERNATIONAL INC.	
Test Site Location	No.58, Aly. 75, Ln. 564, Wenhua 3rd, Rd., Guishan Dist., Taoyuan City, Taiwan (R.O.C.) TEL: +886-3-327-0868 FAX: +886-3-327-0855	
Test Site No.	Sporton Site No.	
	03CH13-HY	

Note: The test site complies with ANSI C63.4 2014 requirement.

1.5 Applicable Standards

According to the specifications of the manufacturer, the EUT must comply with the requirements of the following standards:

- ♦ FCC Part 15 Subpart C §15.247
- ♦ FCC KDB Publication No. 558074 D01 DTS Meas. Guidance v05
- ♦ FCC KDB 414788 D01 Radiated Test Site v01r01.
- ♦ FCC KDB 662911 D01 Multiple Transmitter Output v02r01.
- ♦ ANSI C63.10-2013

Remark: All test items were verified and recorded according to the standards and without any deviation during the test.



2 Test Configuration of Equipment Under Test

- a. The EUT has been associated with peripherals and configuration operated in a manner tended to maximize its emission characteristics in a typical application. Frequency range investigated: conduction emission (150 kHz to 30 MHz), radiation emission (9 kHz to the 10th harmonic of the highest fundamental frequency or to 40 GHz, whichever is lower). For radiated measurement, pre-scanned in two configurations, with accessories and without accessories. The worst case (without accessories) was recorded in this report.

- b. AC power line Conducted Emission was tested under maximum output power.

2.1 Carrier Frequency and Channel

Frequency Band	Channel	Freq. (MHz)	Channel	Freq. (MHz)
2400-2483.5 MHz	1	2412	8	2447
	2	2417	9	2452
	3	2422	10	2457
	4	2427	11	2462
	5	2432	12	2467
	6	2437	13	2472
	7	2442		



2.2 Test Mode

Final test modes are considering the modulation and worse data rates as below table.

Single Antenna

Modulation	Data Rate
802.11b	1 Mbps
802.11g	6 Mbps
802.11n HT20	MCS0

MIMO Antenna

Modulation	Data Rate
802.11b	1 Mbps
802.11g	6 Mbps
802.11n HT20	MCS0

Test Cases	
AC Conducted Emission	Mode 1 :WLAN (2.4GHz) Link + Bluetooth Link with Bluetooth Speaker + DVD player connect Coaxial IN port + 600 ohm load connect Line IN port + 75 ohm load connect Coaxial OUT port + 600 ohm load connect Subwoofer OUT port + 600 ohm load connect Line OUT port + 8 ohm load connect Left channel OUT port + 8 ohm load connect Right channel OUT port + MP3 from Coaxial IN port + Power cable

2.3 Connection Diagram of Test System

<WLAN Tx Mode>

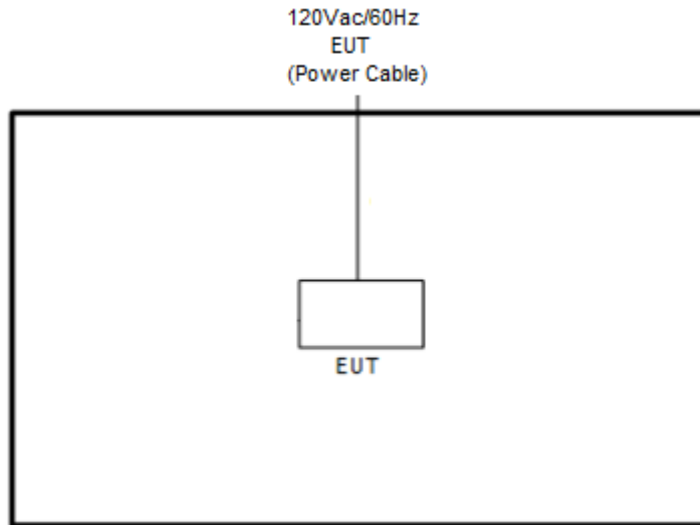

<AC Conducted Emission Mode>

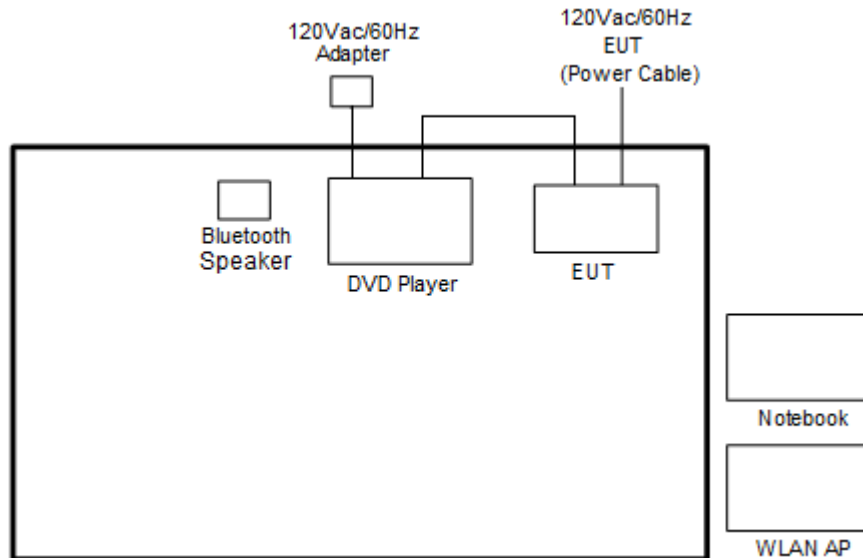

2.4 Support Unit used in test configuration and system

Item	Equipment	Trade Name	Model Name	FCC ID	Data Cable	Power Cord
1.	Bluetooth Speaker	Jambox	Mini Jambox	FCC DoC	N/A	N/A
2.	WLAN AP	ASUS	RT-AC66U	MSQ-RTAC66U	N/A	Unshielded, 1.8 m
3.	DVD Player	Sony	BDP-S370	FCC DoC	Unshielded, 1.2 m	N/A
4.	Notebook	DELL	Latitude E5570	FCC DoC	N/A	AC I/P: Unshielded, 1.2 m DC O/P: Shielded, 1.8 m

2.5 EUT Operation Test Setup

The RF test items, utility “CMD” was installed in Notebook which was programmed in order to make the EUT get into the engineering modes to provide channel selection, power level, data rate and the application type and for continuous transmitting signals.

2.6 Measurement Results Explanation Example

For all conducted test items:

The offset level is set in the spectrum analyzer to compensate the RF cable loss and attenuator factor between EUT conducted output port and spectrum analyzer. With the offset compensation, the spectrum analyzer reading level is exactly the EUT RF output level.

Example:

The spectrum analyzer offset is derived from RF cable loss and attenuator factor.

Offset = RF cable loss + attenuator factor.

Following shows an offset computation example with cable loss 4.2 dB and 10dB attenuator.

Offset(dB) = RF cable loss(dB) + attenuator factor(dB).

= 4.2 + 10 = 14.2 (dB)

3 Test Result

3.1 6dB and 99% Bandwidth Measurement

3.1.1 Limit of 6dB and 99% Bandwidth

The minimum 6 dB bandwidth shall be at least 500 kHz.

3.1.2 Measuring Instruments

See list of measuring equipment of this test report.

3.1.3 Test Procedures

1. The testing follows FCC KDB Publication No. 558074 DTS D01 Meas. Guidance v05.
2. The RF output of EUT was connected to the spectrum analyzer by RF cable and attenuator. The path loss was compensated to the results for each measurement.
3. Set to the maximum power setting and enable the EUT transmit continuously.
4. Make the measurement with the spectrum analyzer's resolution bandwidth (RBW) = 100 kHz. Set the Video bandwidth (VBW) = 300 kHz. In order to make an accurate measurement. The 6 dB bandwidth must be greater than 500 kHz.
5. For 99% Bandwidth Measurement, the spectrum analyzer's resolution bandwidth (RBW) is set 1-5% of the emission bandwidth and set the Video bandwidth (VBW) $\geq 3 * RBW$.
6. Measure and record the results in the test report.

3.1.4 Test Setup

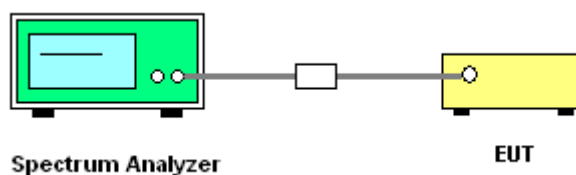



3.1.5 Test Result of 6dB and 99% Occupied Bandwidth

Please refer to Appendix A.

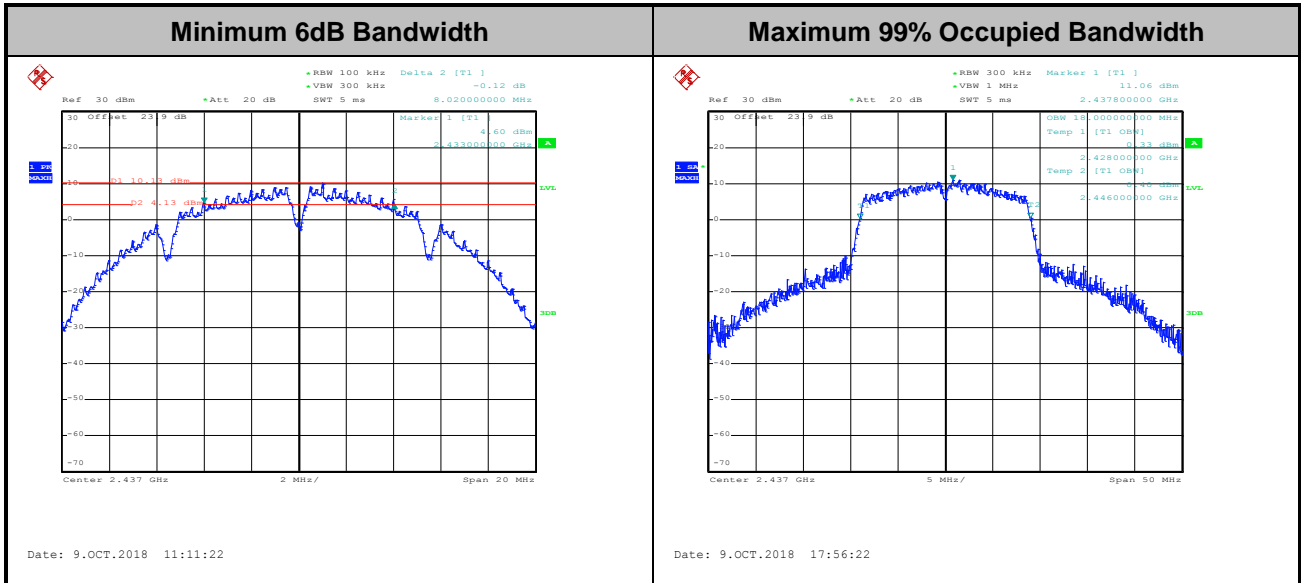

Note: The occupied channel bandwidth is maintained within the band of operation for all of the modulations.

3.2 Output Power Measurement

3.2.1 Limit of Output Power

For systems using digital modulation in the 2400-2483.5MHz, the limit for peak output power is 30dBm. If transmitting antenna with directional gain greater than 6dBi is used, the peak output power from the intentional radiator shall be reduced below the above stated value by the amount in dB that the directional gain of the antenna exceeds 6 dBi. In case of point-to-point operation, the limit has to be reduced by 1dB for every 3dB that the directional gain of the antenna exceeds 6dBi.

3.2.2 Measuring Instruments

See list of measuring equipment of this test report.

3.2.3 Test Procedures

1. For Peak Power, the testing follows the Measurement Procedure of FCC KDB No. 558074 DTS D01 Meas. Guidance v05 section 9.1.3 PKPM1 Peak power meter method.
2. For Average Power, the testing follows the Measurement Procedure of FCC KDB No. 558074 DTS D01 Meas. Guidance v05 section 9.2.3.1 Method AVGPM.
3. The RF output of EUT was connected to the power meter by RF cable and attenuator. The path loss was compensated to the results for each measurement.
4. Set to the maximum power setting and enable the EUT transmit continuously.
5. Measure the conducted output power and record the results in the test report.
6. For MIMO mode, calculation method follows FCC KDB 662911 D01 Multiple Transmitter Output v02r01.

3.2.4 Test Setup

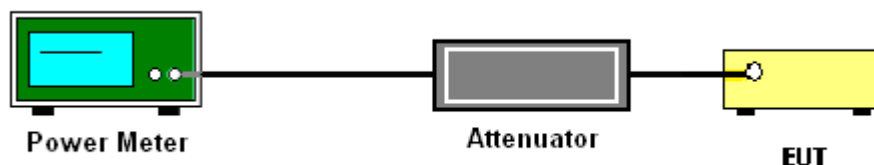

3.2.5 Test Result of Peak Output Power

Please refer to Appendix A.

3.2.6 Test Result of Average output Power (Reporting Only)

Please refer to Appendix A.



3.3 Power Spectral Density Measurement

3.3.1 Limit of Power Spectral Density

The peak power spectral density shall not be greater than 8dBm in any 3kHz band at any time interval of continuous transmission.

3.3.2 Measuring Instruments

See list of measuring equipment of this test report.

3.3.3 Test Procedures

1. The testing follows Measurement Procedure 10.2 Method PKPSD of FCC KDB Publication No. 558074 D01 DTS Meas. Guidance v05
2. The RF output of EUT was connected to the spectrum analyzer by RF cable and attenuator. The path loss was compensated to the results for each measurement.
3. Set to the maximum power setting and enable the EUT transmit continuously.
4. Make the measurement with the spectrum analyzer's resolution bandwidth (RBW) = 3 kHz. Video bandwidth VBW = 10 kHz In order to make an accurate measurement, set the span to 1.5 times DTS Channel Bandwidth. (6dB BW)
5. Detector = peak, Sweep time = auto couple, Trace mode = max hold, Allow trace to fully stabilize. Use the peak marker function to determine the maximum power level.
6. Measure and record the results in the test report.
7. For MIMO mode, calculation method follows FCC KDB 662911 D01 Multiple Transmitter Output v02r01.

If measurements performed using method (2) plus $10 \log(N)$ exceeds the emission limit, the test should choose method (1) before declaring that the device fails the emission limit.

Method (1): Measure and sum the spectra across the outputs.

The total final Power Spectral Density is from a device with 2 transmitter outputs. The spectrum measurements of the individual outputs are all performed with the same span and number of points, the spectrum value in the first spectral bin of output 1 is summed with that in the first spectral bin of output 2 to obtain the value for the first frequency bin of the summed spectrum.

Method (2): Measure and add $10 \log(N)$ dB, where N is the number of outputs. (N=2)

3.3.4 Test Setup

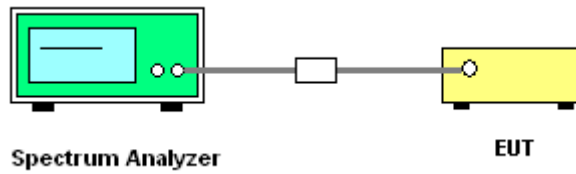

3.3.5 Test Result of Power Spectral Density

Please refer to Appendix A.

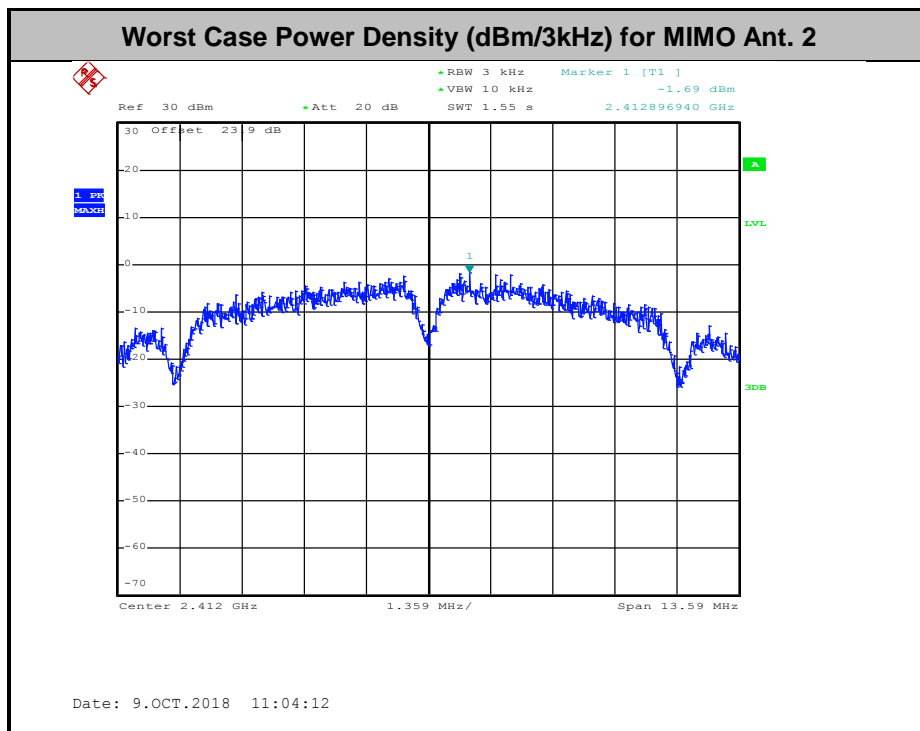
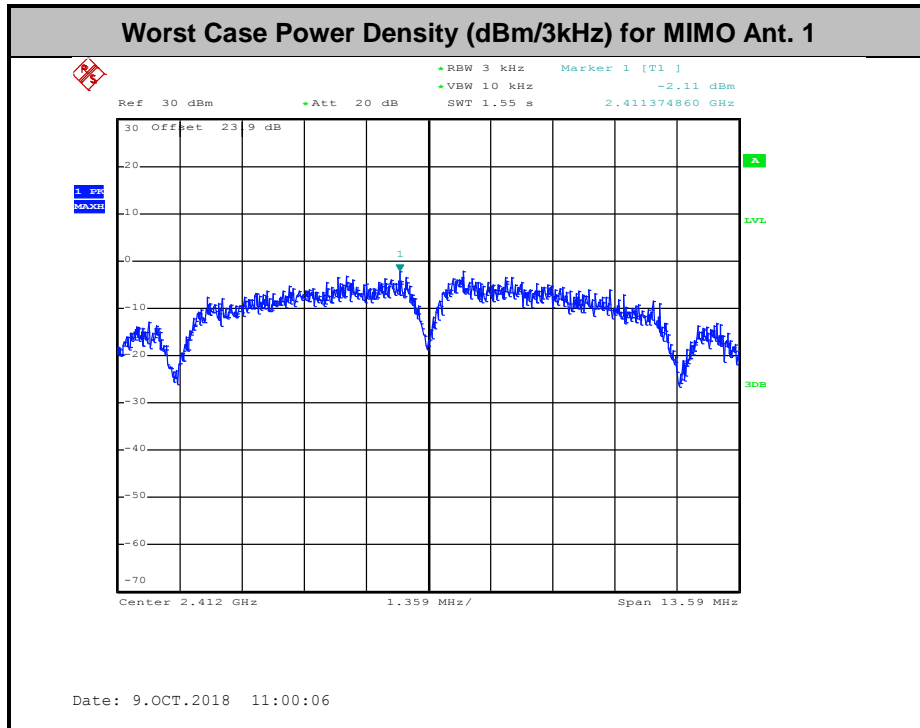

3.4 Conducted Band Edges and Spurious Emission Measurement

3.4.1 Limit of Conducted Band Edges and Spurious Emission Measurement

In any 100 kHz bandwidth outside of the authorized frequency band, the emissions which fall in the non-restricted bands shall be attenuated at least 20 dB / 30dB relative to the maximum PSD level in 100 kHz by RF conducted measurement.

3.4.2 Measuring Instruments

See list of measuring equipment of this test report.

3.4.3 Test Procedures

1. The testing follows FCC KDB Publication No. 558074 D01 DTS Meas. Guidance v05.
2. The RF output of EUT was connected to the spectrum analyzer by RF cable and attenuator. The path loss was compensated to the results for each measurement.
3. Set to the maximum power setting and enable the EUT transmit continuously.
4. Set RBW = 100 kHz, VBW=300 kHz, Peak Detector. Unwanted Emissions measured in any 100 kHz bandwidth outside of the authorized frequency band shall be attenuated by at least 20 dB relative to the maximum in-band peak PSD level in 100 kHz when maximum peak conducted output power procedure is used. If the transmitter complies with the conducted power limits based on the use of RMS averaging over a time interval, the attenuation required under this paragraph shall be 30 dB instead of 20 dB per 15.247(d).
5. Measure and record the results in the test report.
6. The RF fundamental frequency should be excluded against the limit line in the operating frequency band.

3.4.4 Test Setup

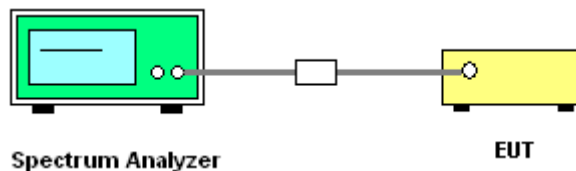



3.4.5 Test Result of Conducted Band Edges and Spurious Emission

Test Engineer : Luffy Lin and Allen Lin	Temperature :	21~25°C
	Relative Humidity :	51~54%

Number of TX = 1, Ant. 1 (Measured)

Test Mode :	802.11b	Test Channel :	01
-------------	---------	----------------	----

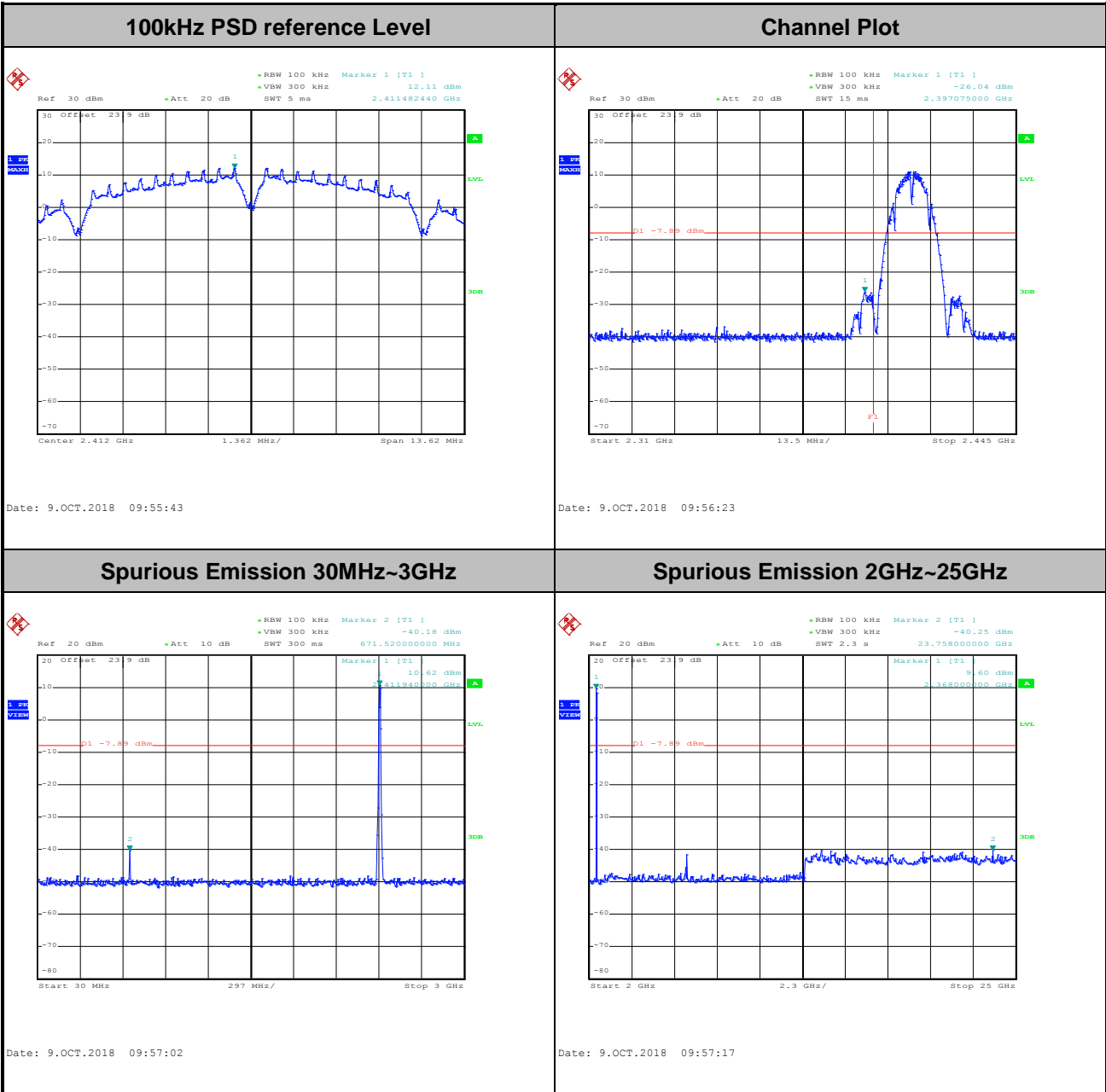



Test Mode :	802.11b	Test Channel :	06
-------------	---------	----------------	----

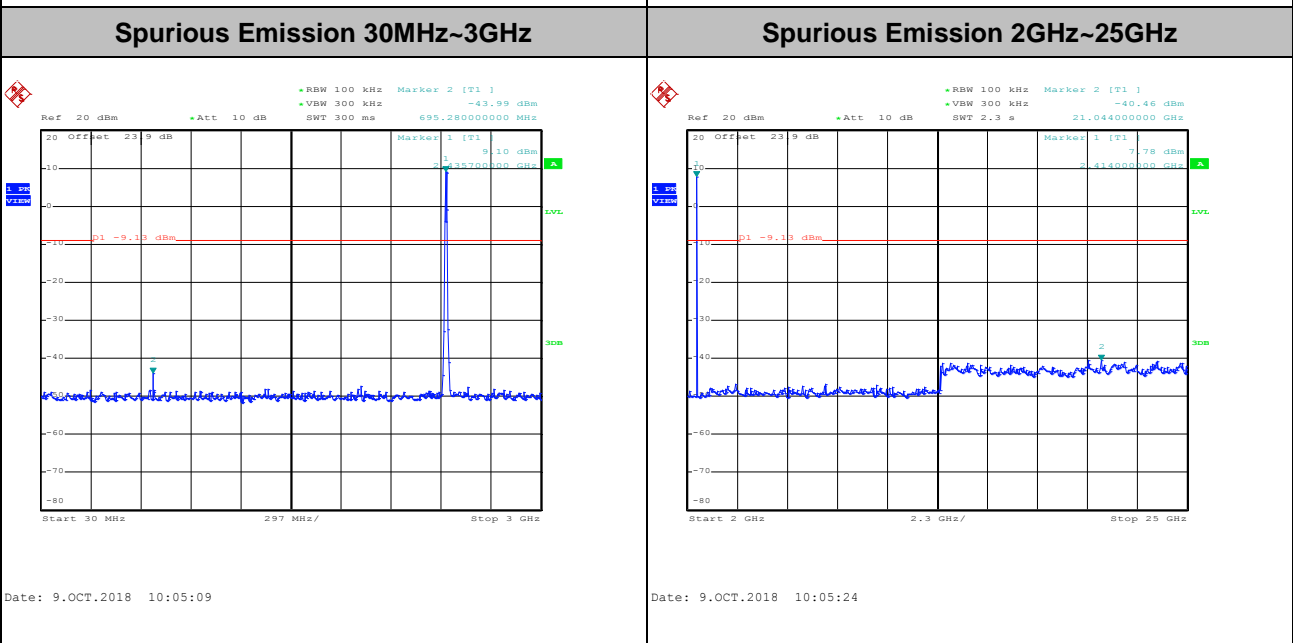
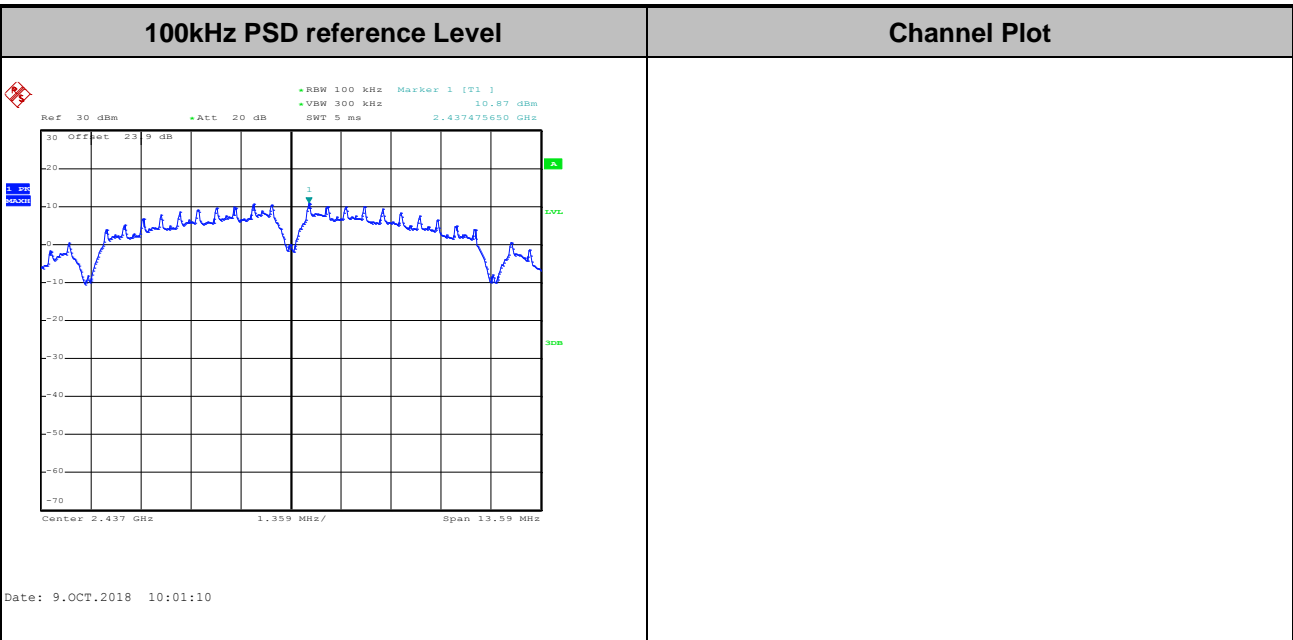



Test Mode :	802.11b	Test Channel :	11
-------------	---------	----------------	----

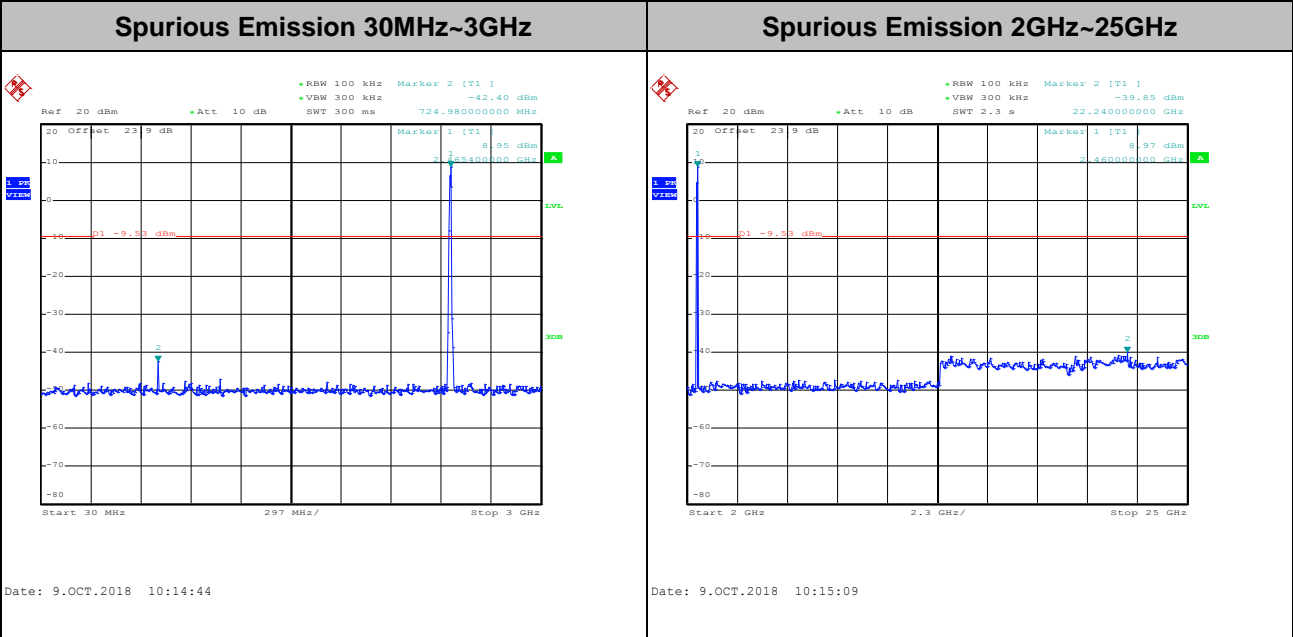
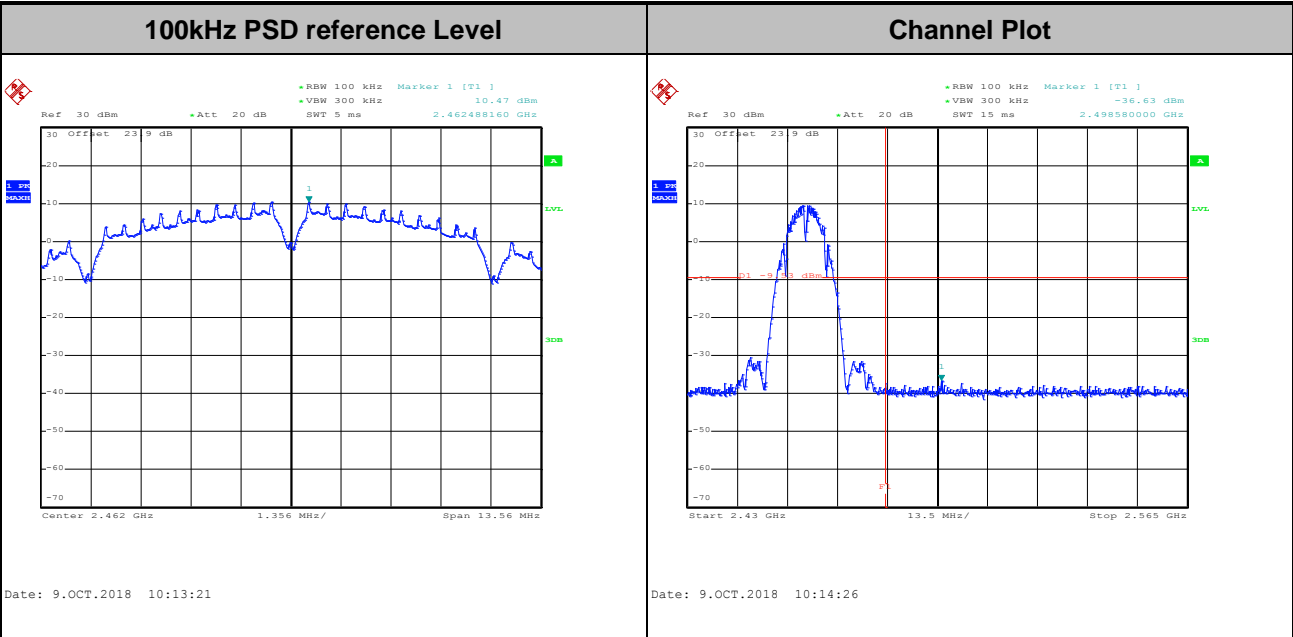



Test Mode :	802.11b	Test Channel :	12
-------------	---------	----------------	----

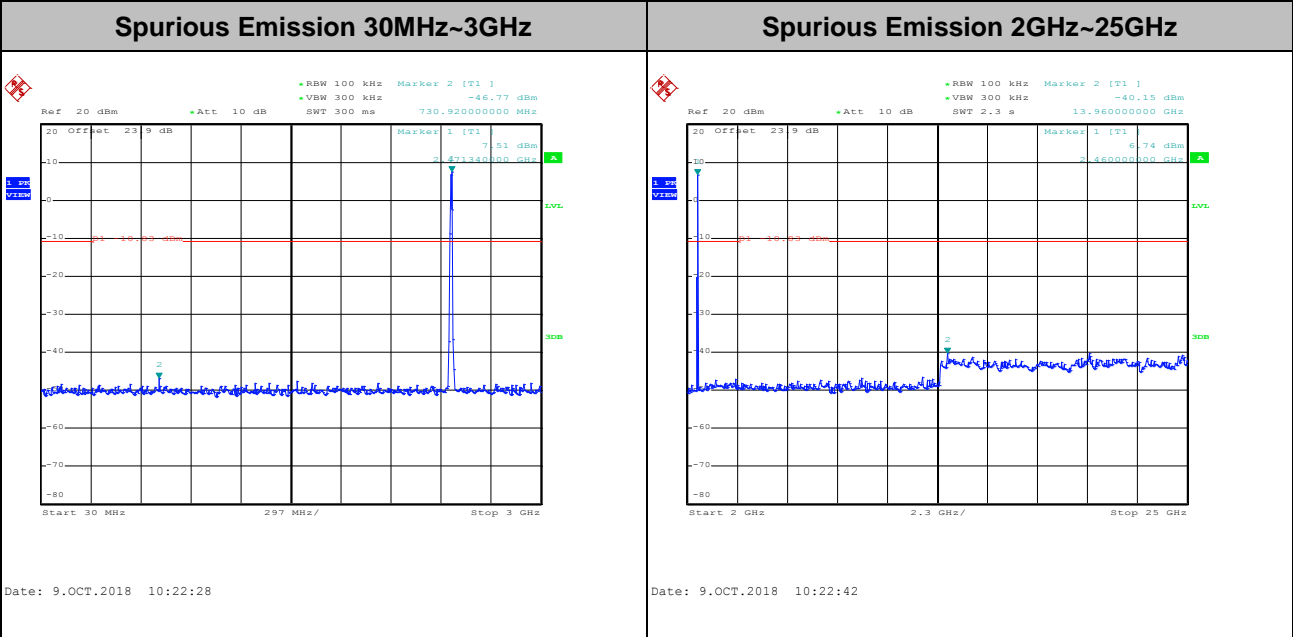
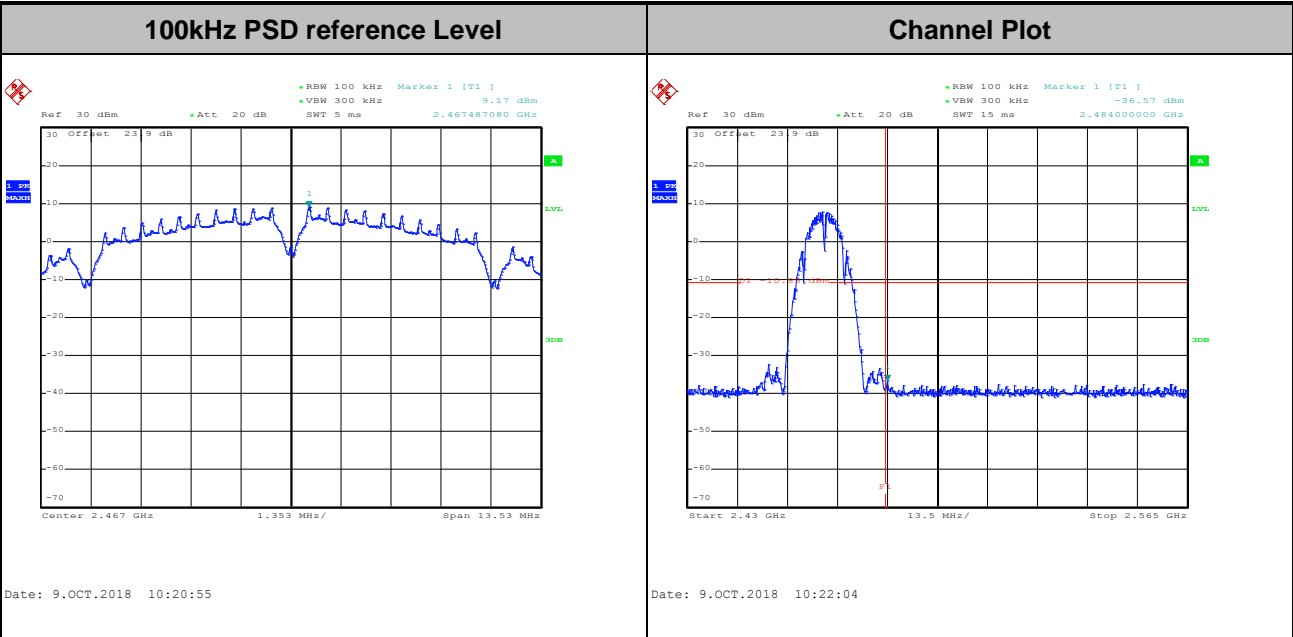



Test Mode :	802.11b	Test Channel :	13
-------------	---------	----------------	----

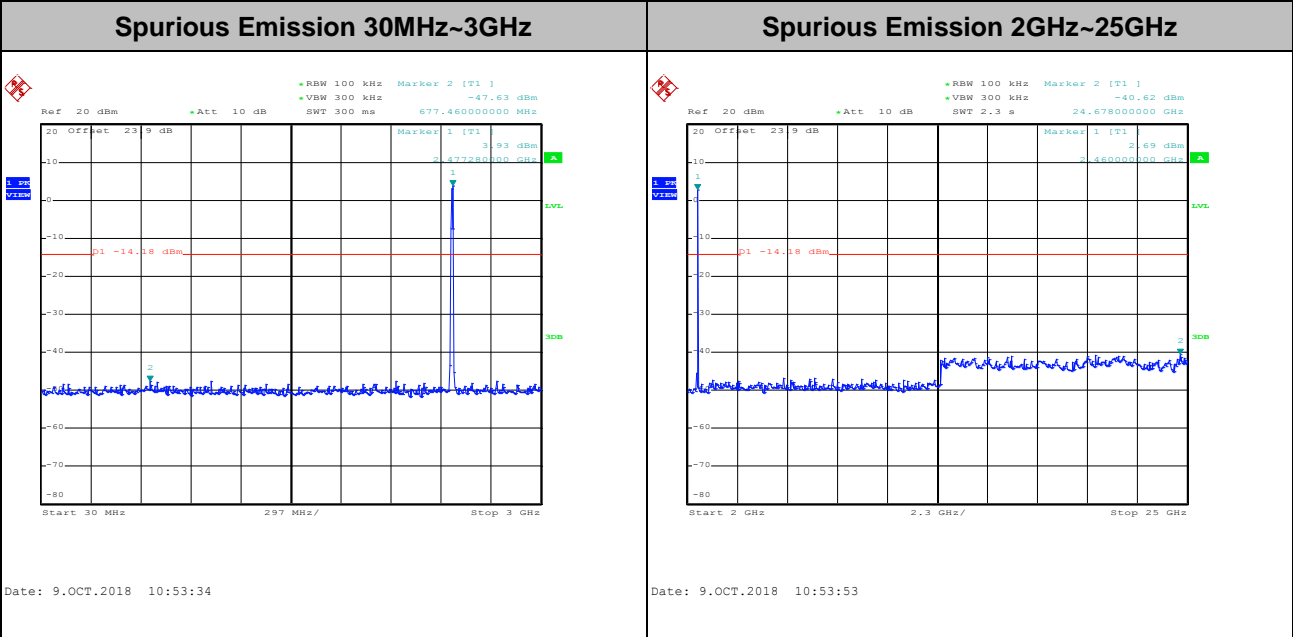
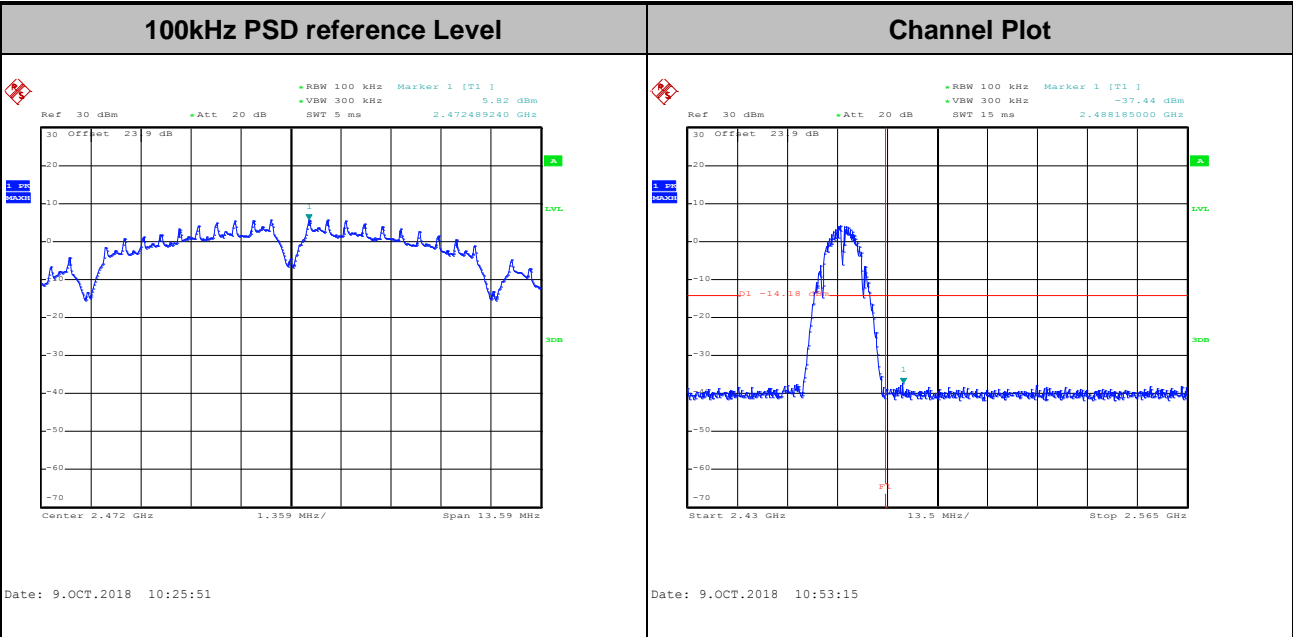



Test Mode : 802.11g Test Channel : 01

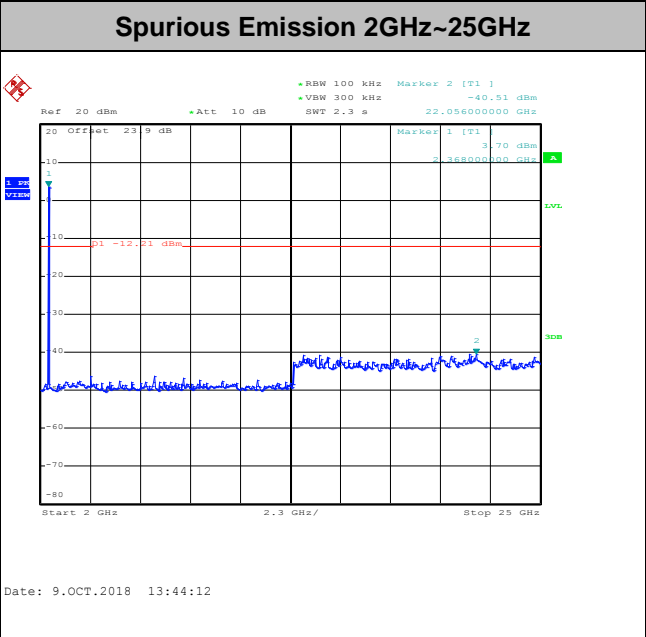
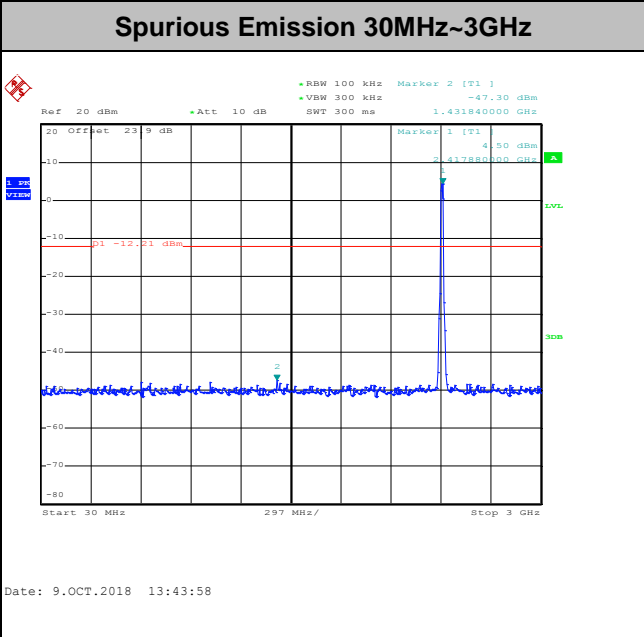
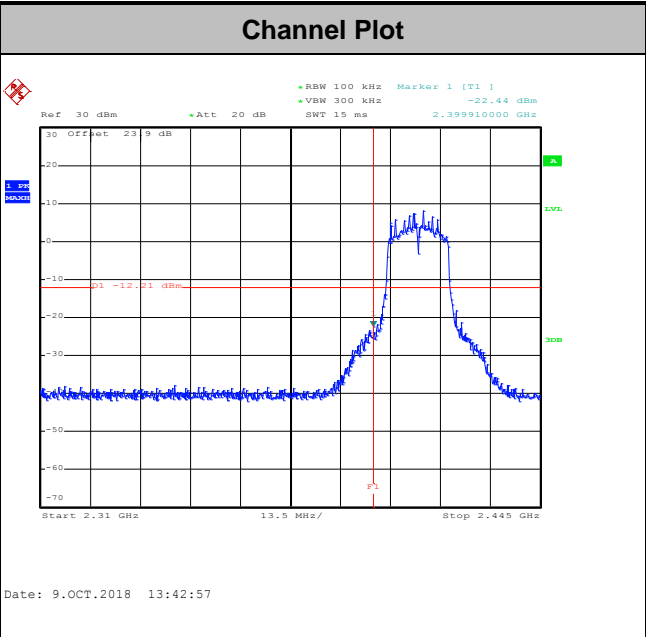
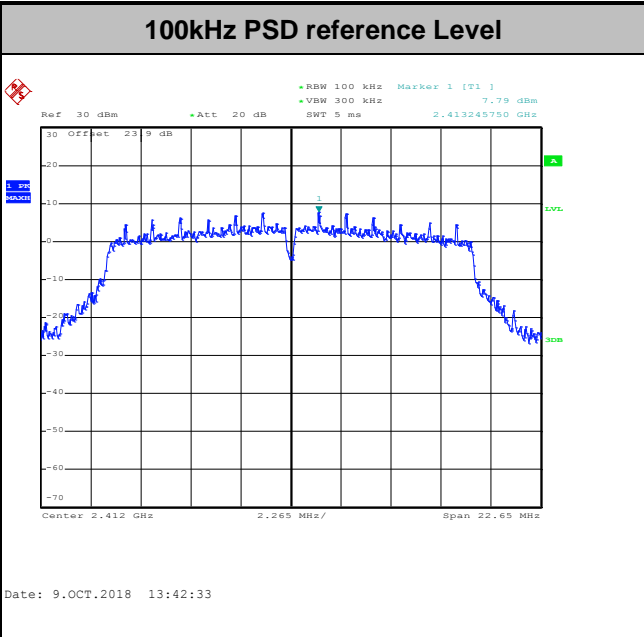



Test Mode :	802.11g	Test Channel :	06
-------------	---------	----------------	----

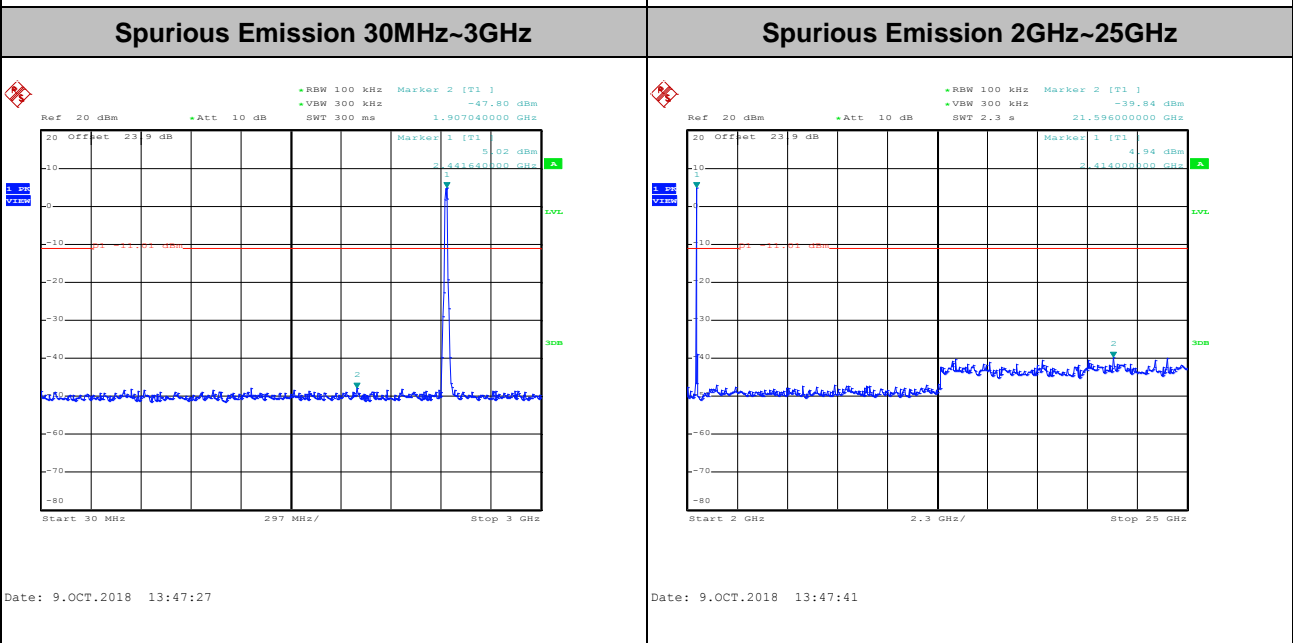
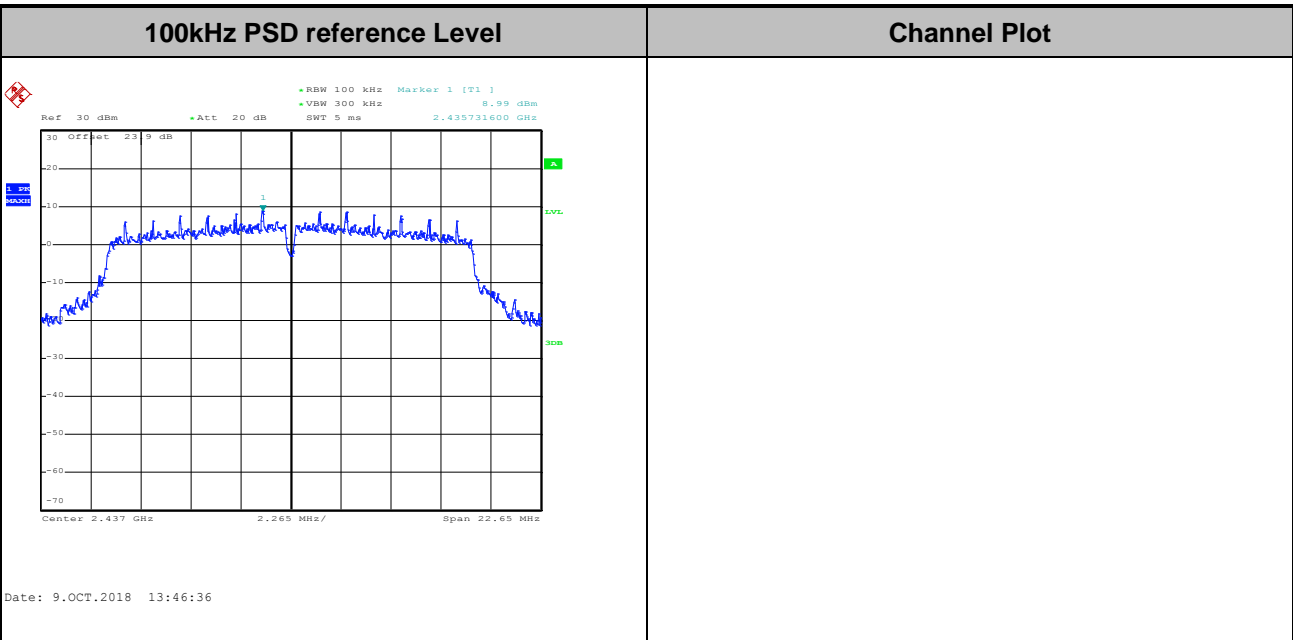



Test Mode :	802.11g	Test Channel :	11
-------------	---------	----------------	----

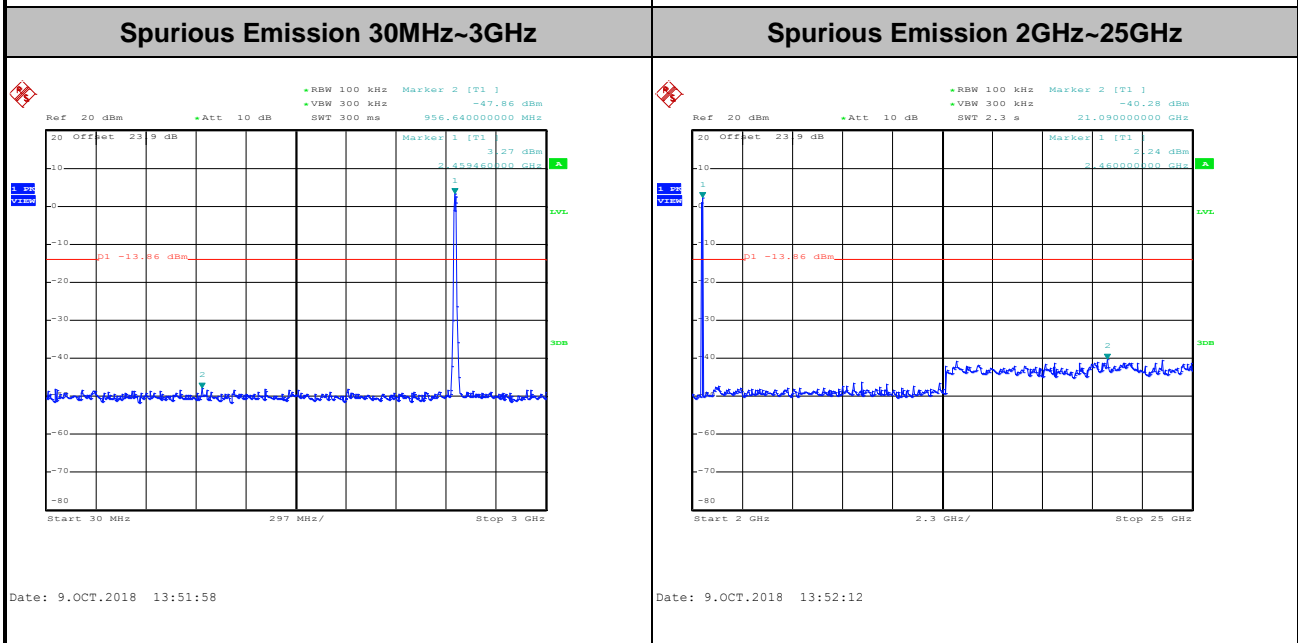
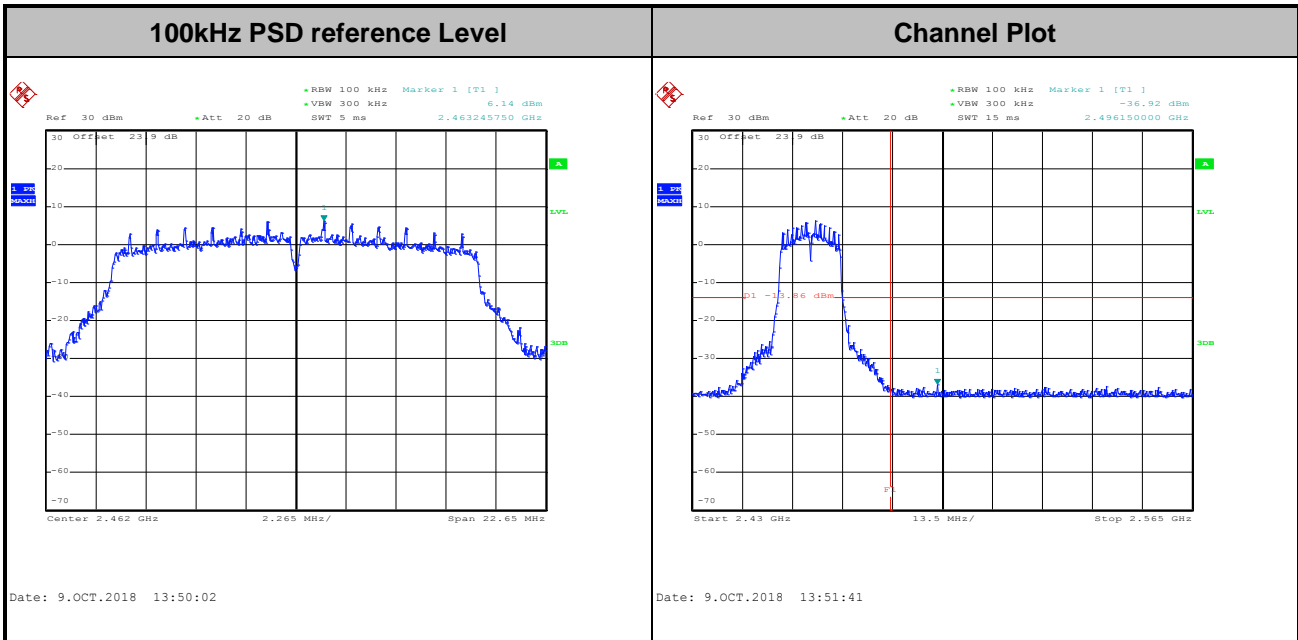



Test Mode :	802.11g	Test Channel :	12
-------------	---------	----------------	----

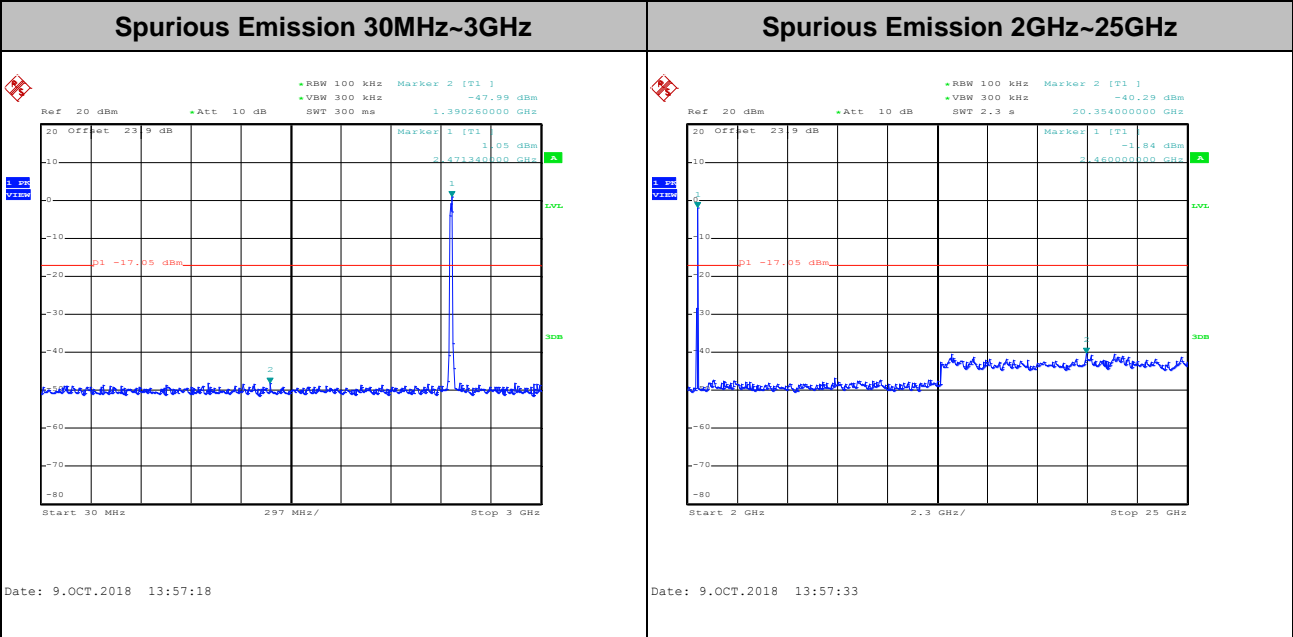
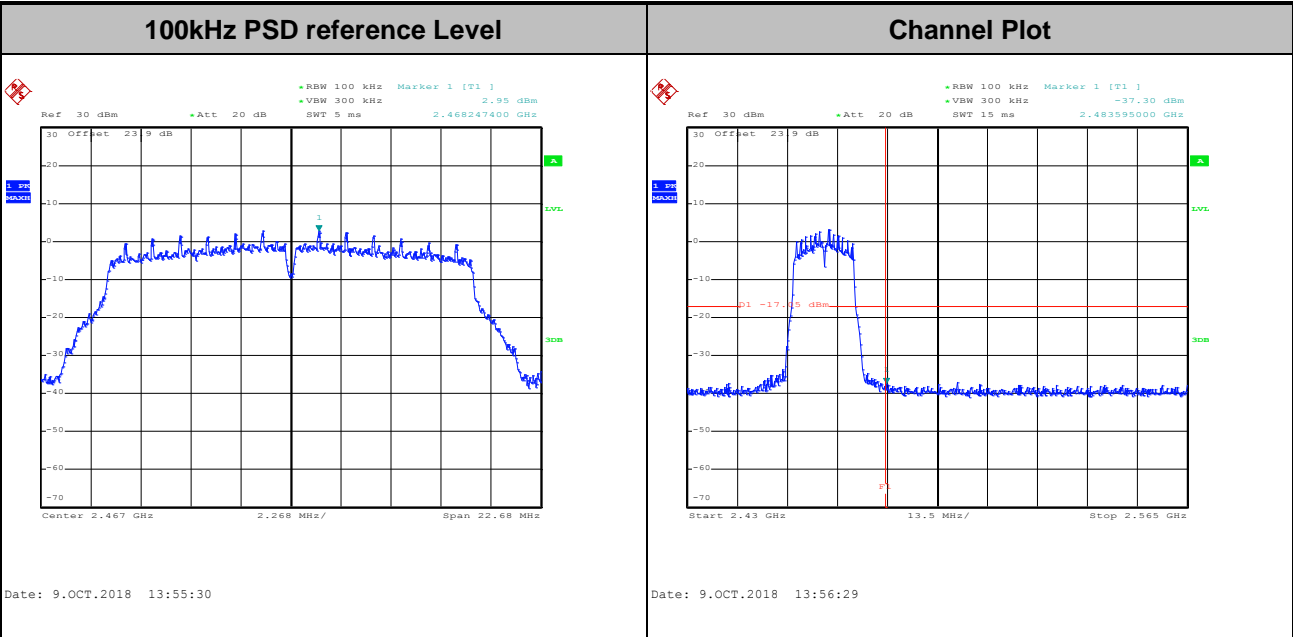



Test Mode :	802.11g	Test Channel :	13
-------------	---------	----------------	----

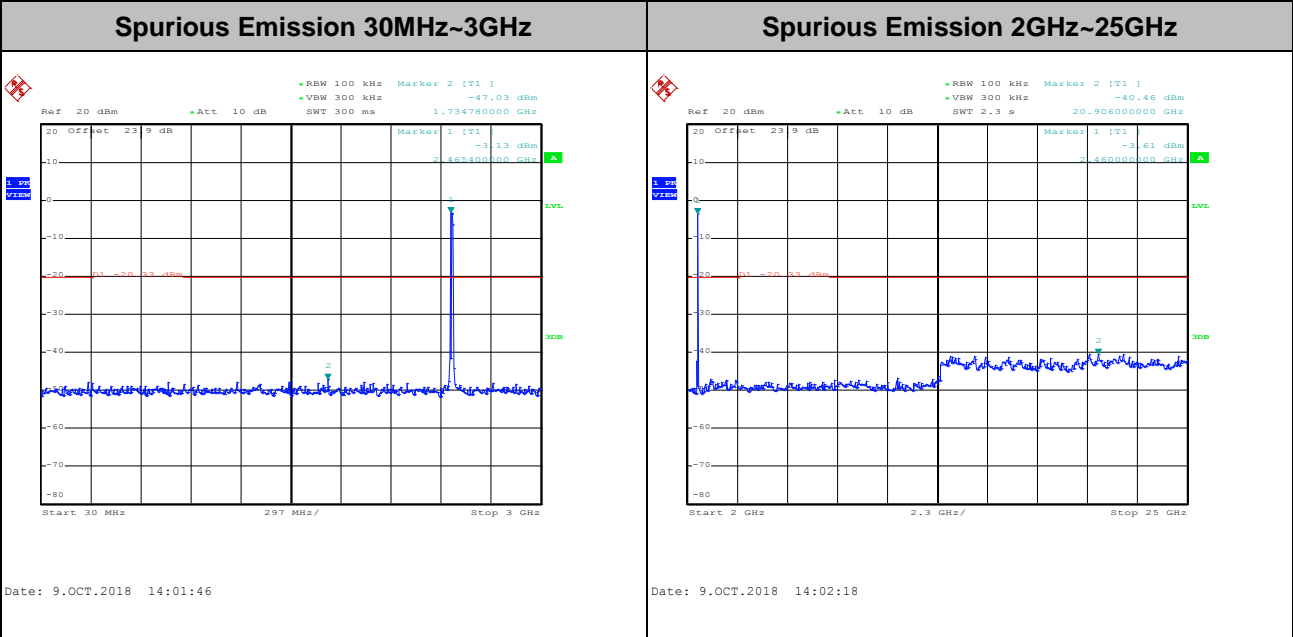
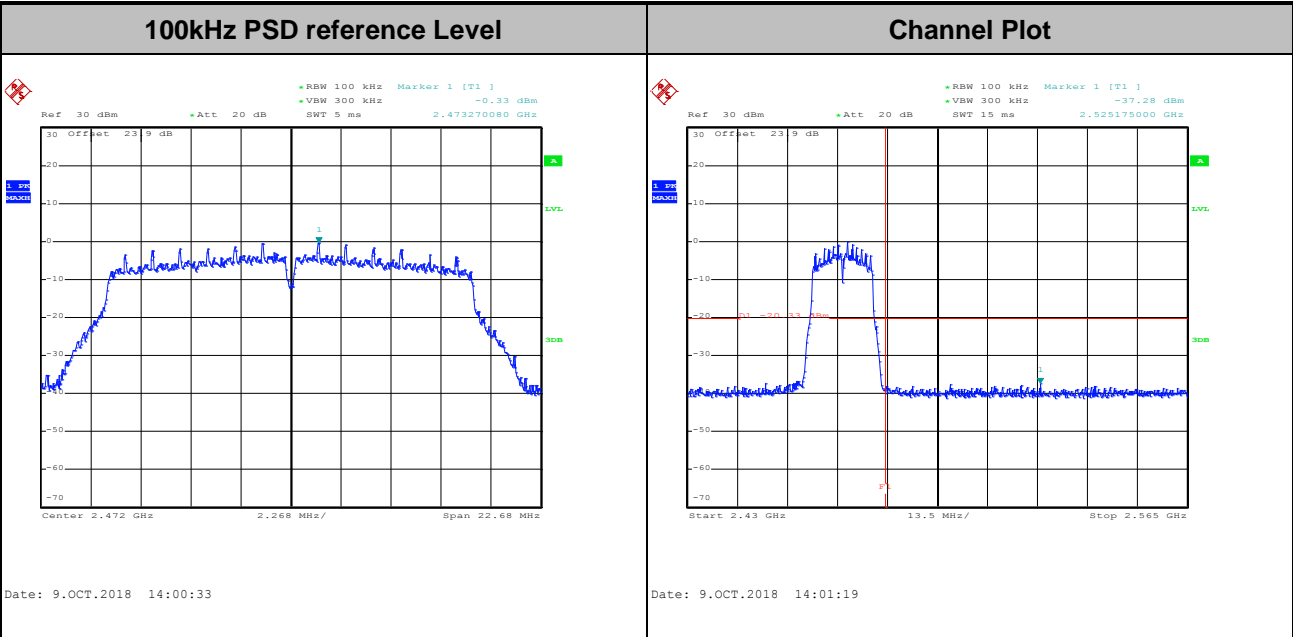



Test Mode :	802.11n HT20	Test Channel :	01
-------------	--------------	----------------	----

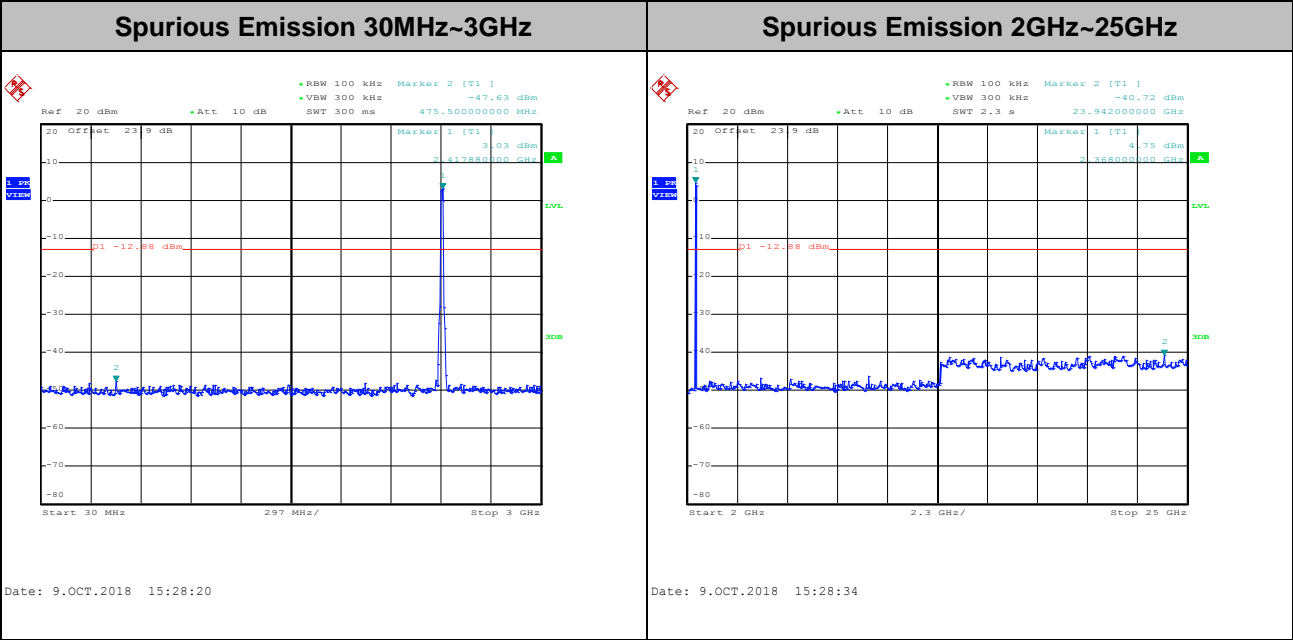
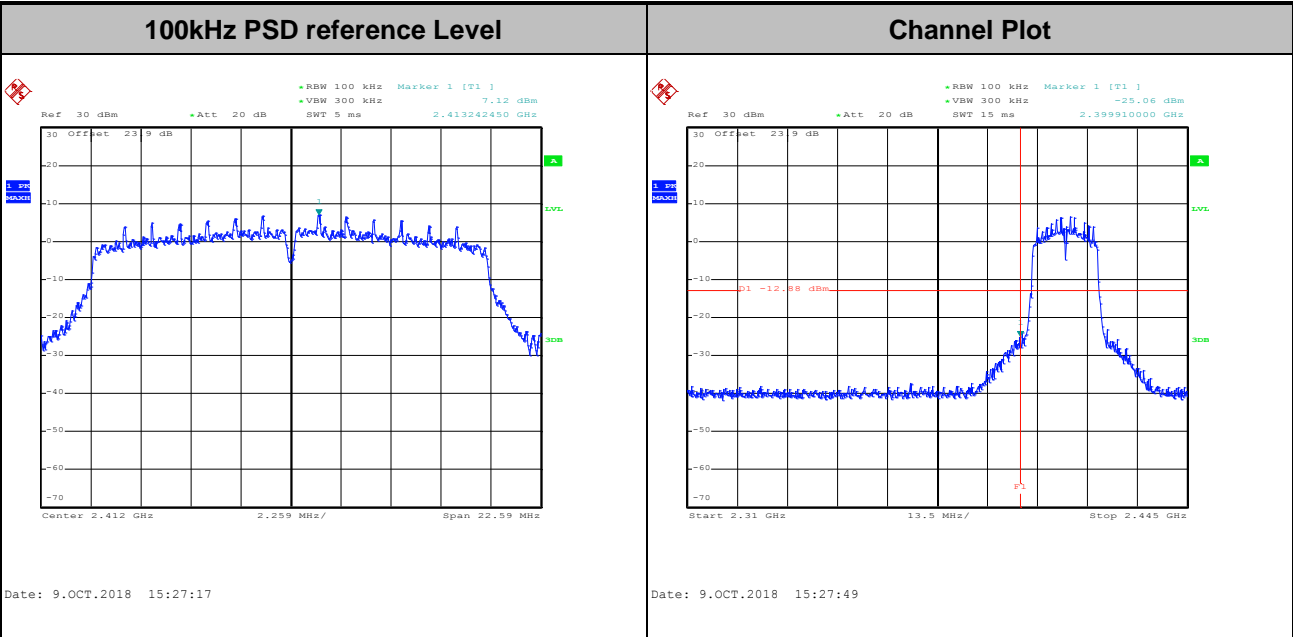



Test Mode :	802.11n HT20	Test Channel :	06
-------------	--------------	----------------	----

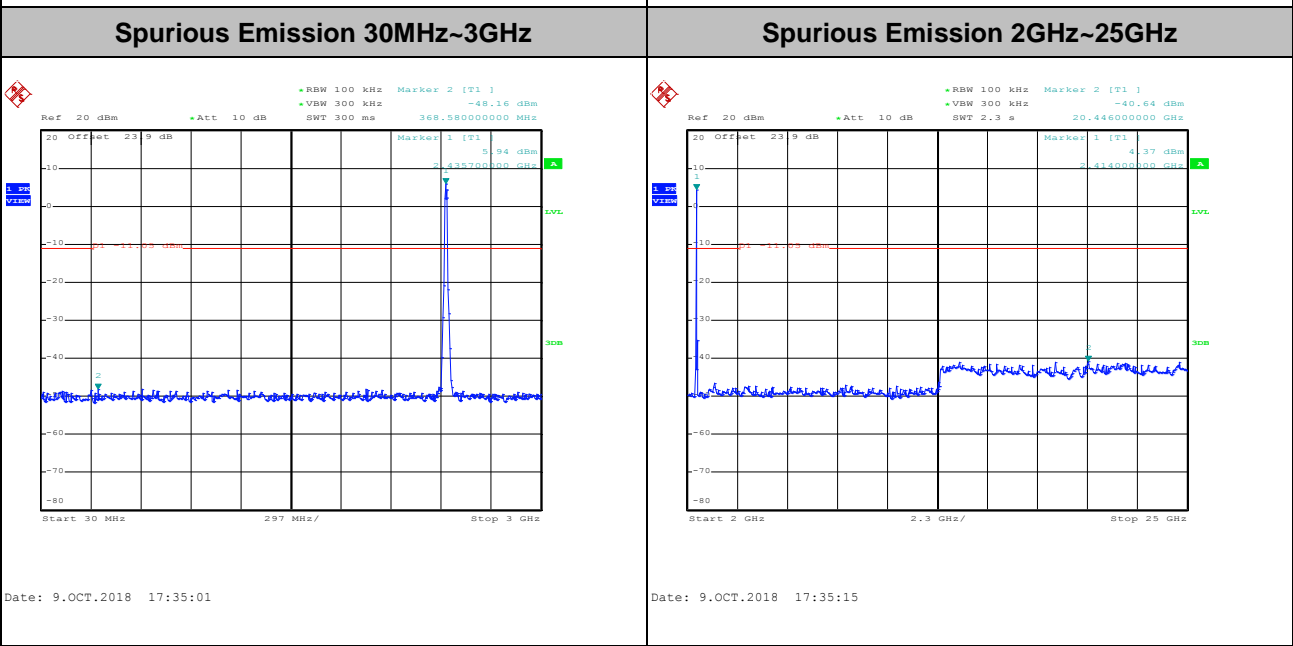
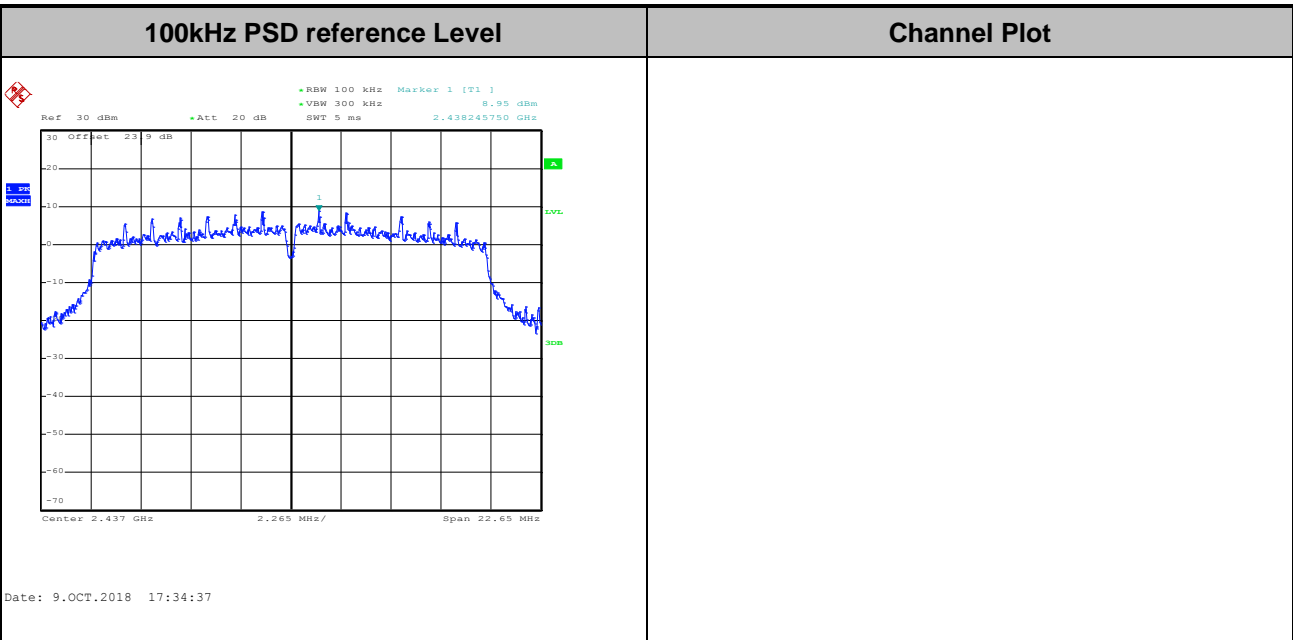



Test Mode :	802.11n HT20	Test Channel :	11
-------------	--------------	----------------	----

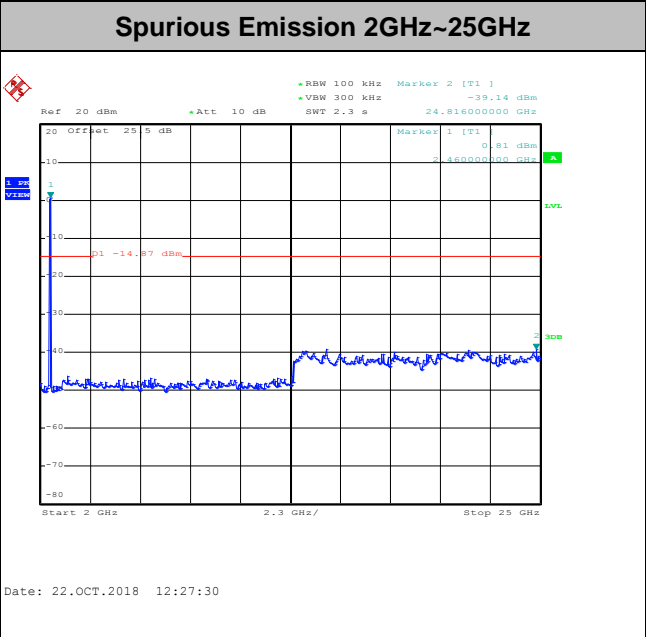
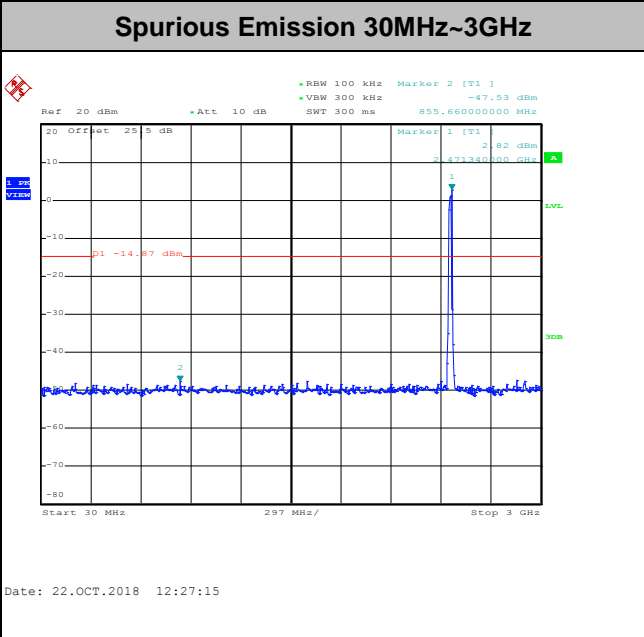
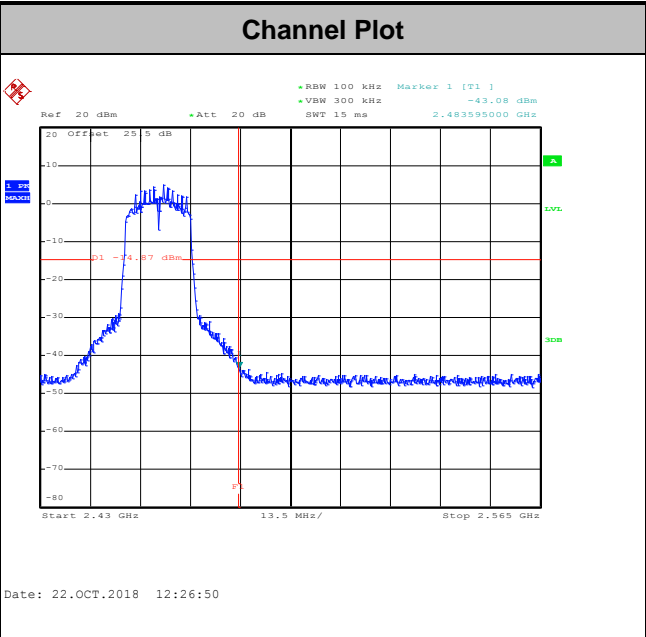
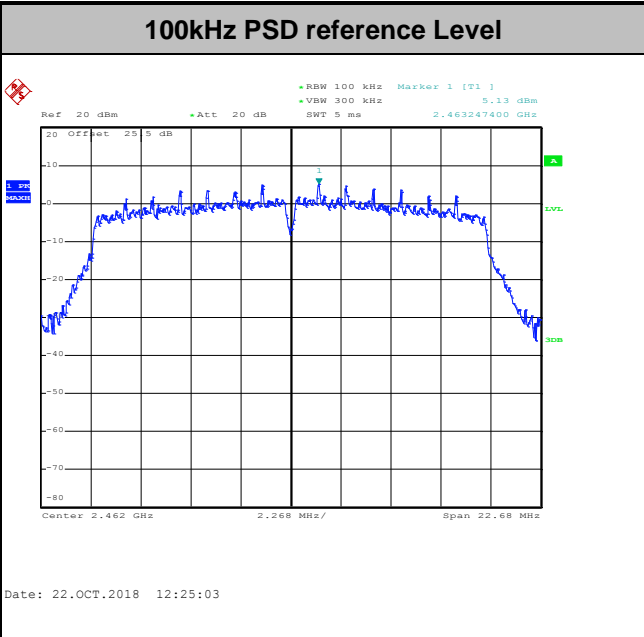



Test Mode :	802.11n HT20	Test Channel :	12
-------------	--------------	----------------	----

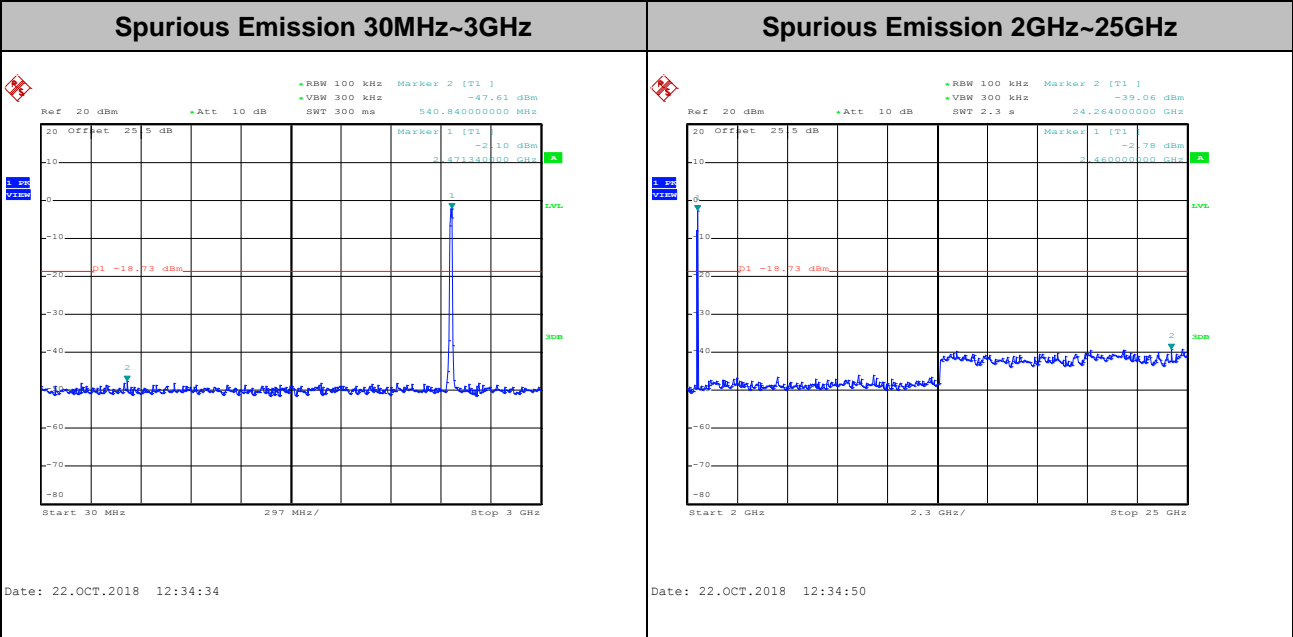
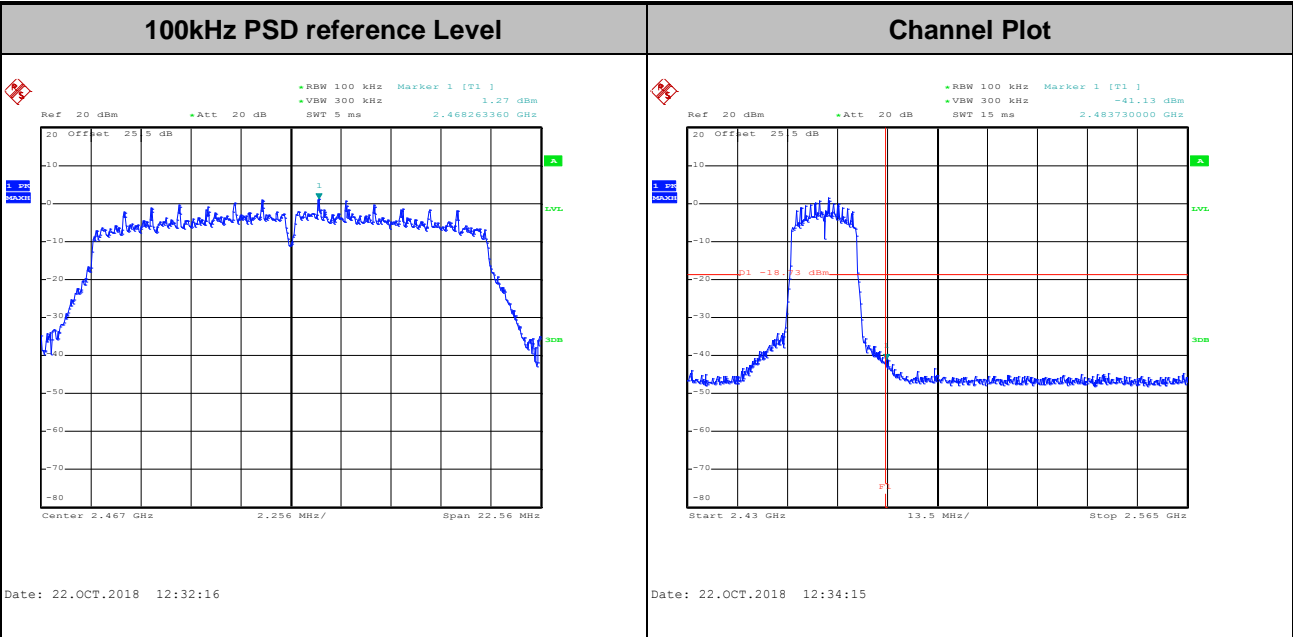



Test Mode :	802.11n HT20	Test Channel :	13
-------------	--------------	----------------	----

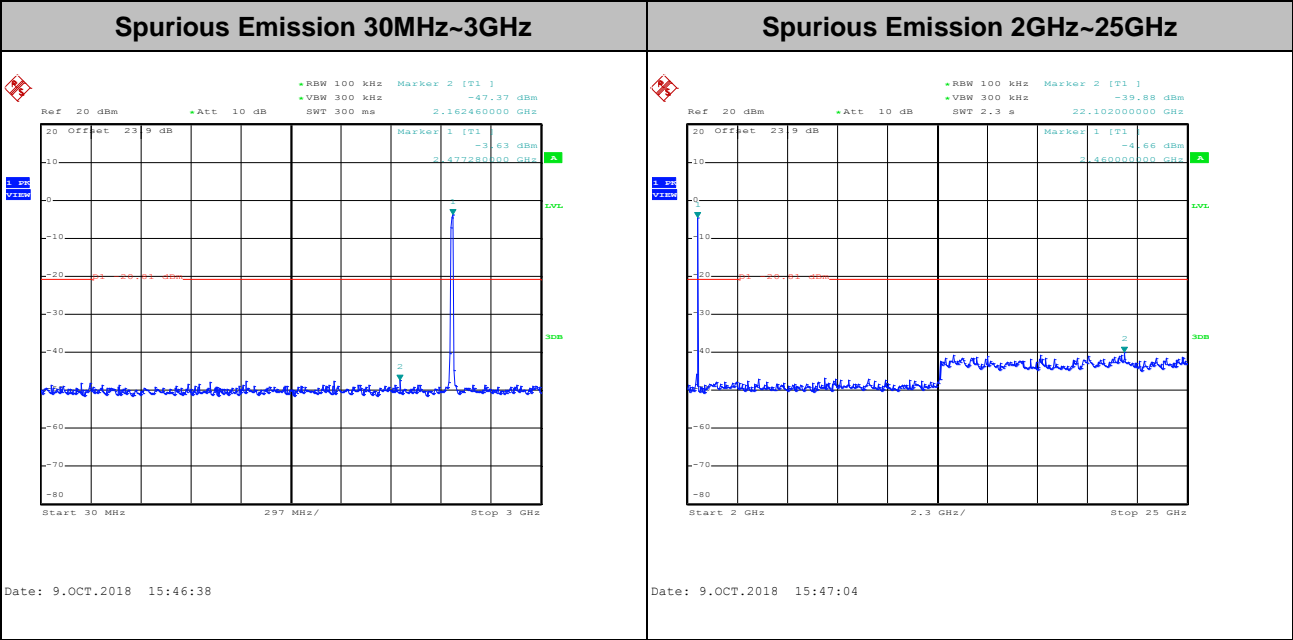
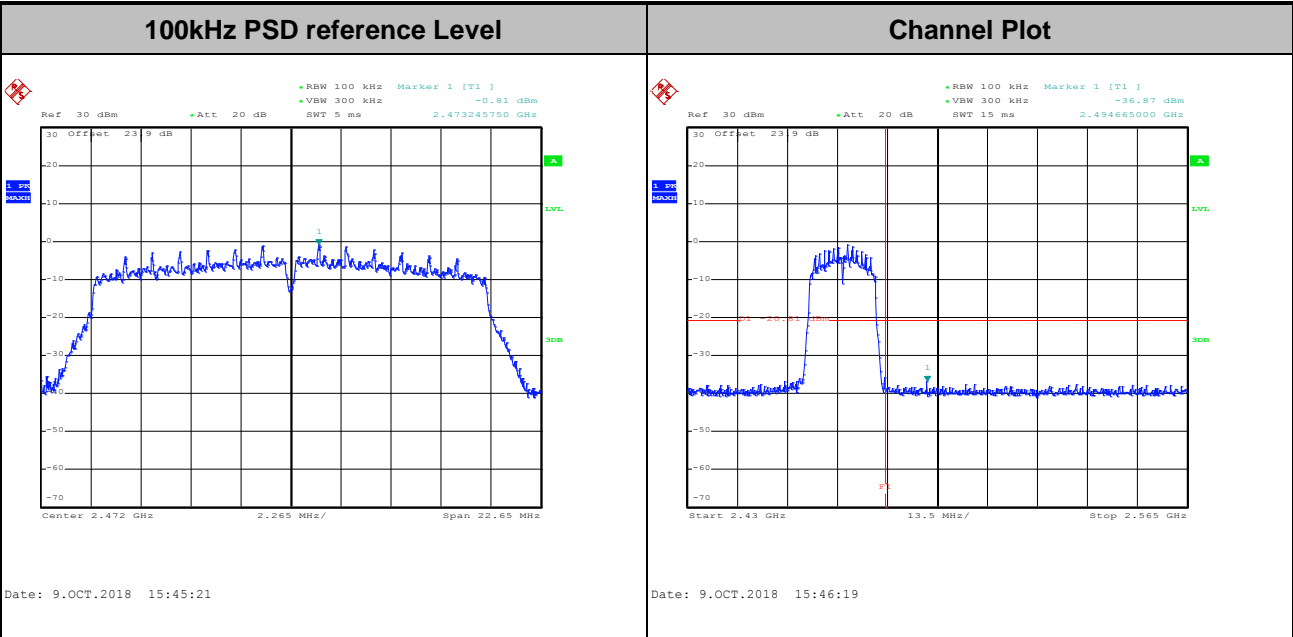



Number of TX = 1, Ant. 2 (Measured)

Test Mode :	802.11b	Test Channel :	01
-------------	---------	----------------	----

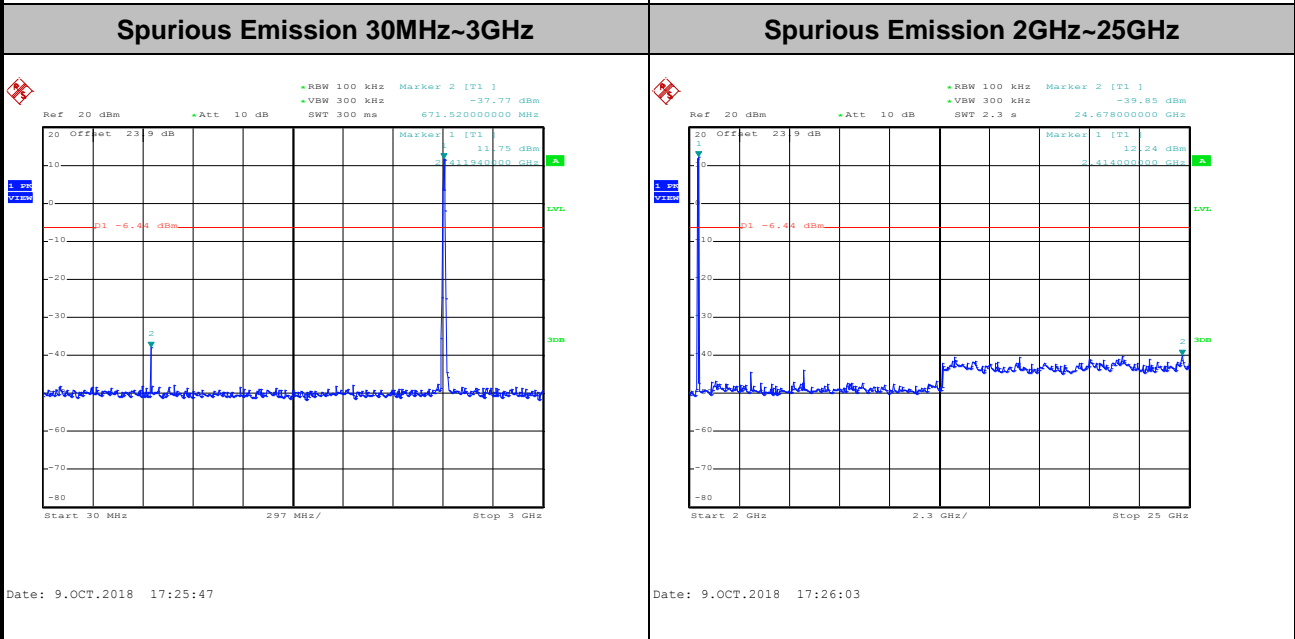
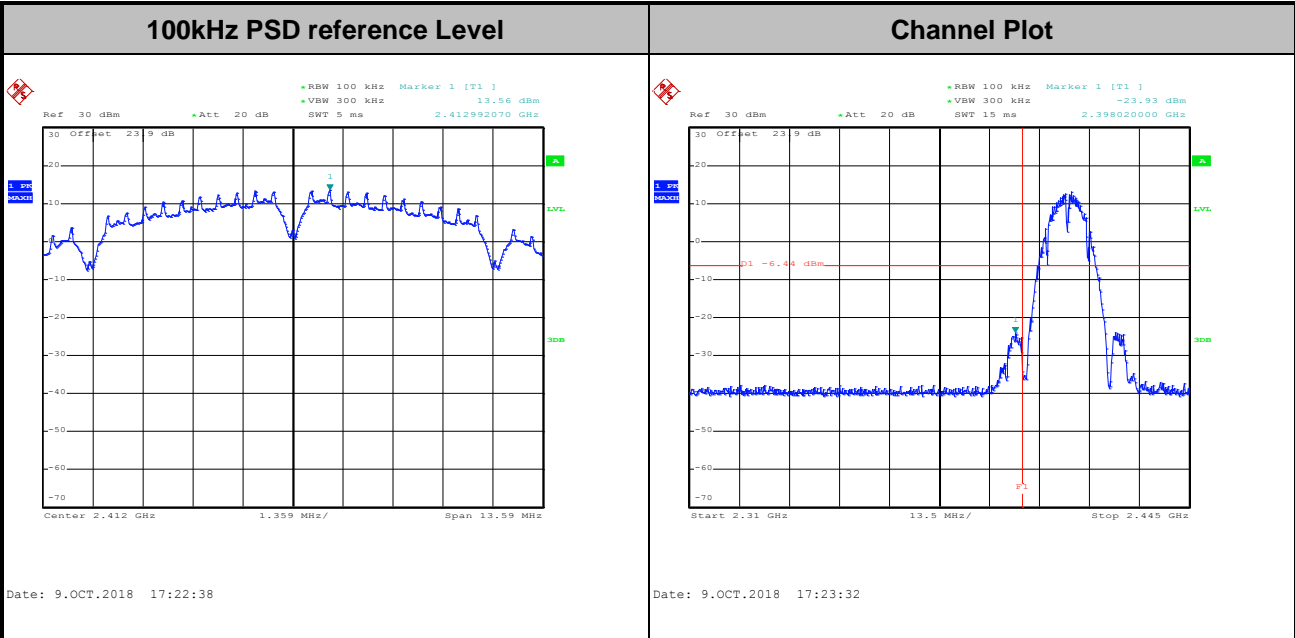



Test Mode :	802.11b	Test Channel :	06
-------------	---------	----------------	----

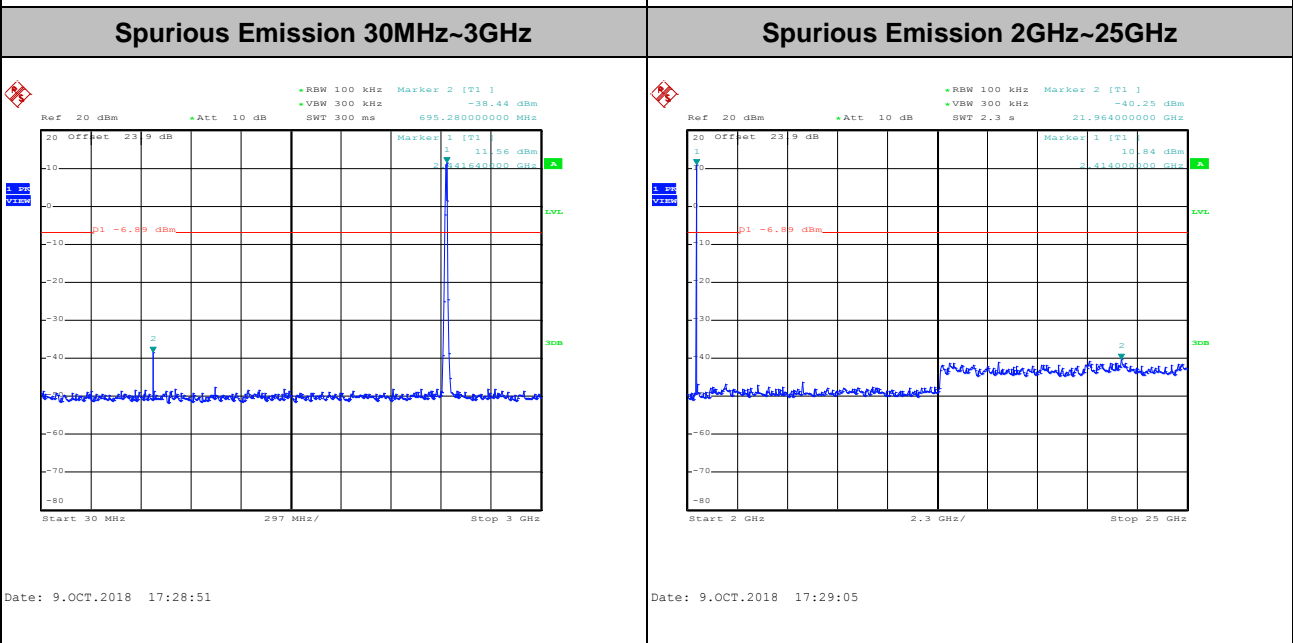
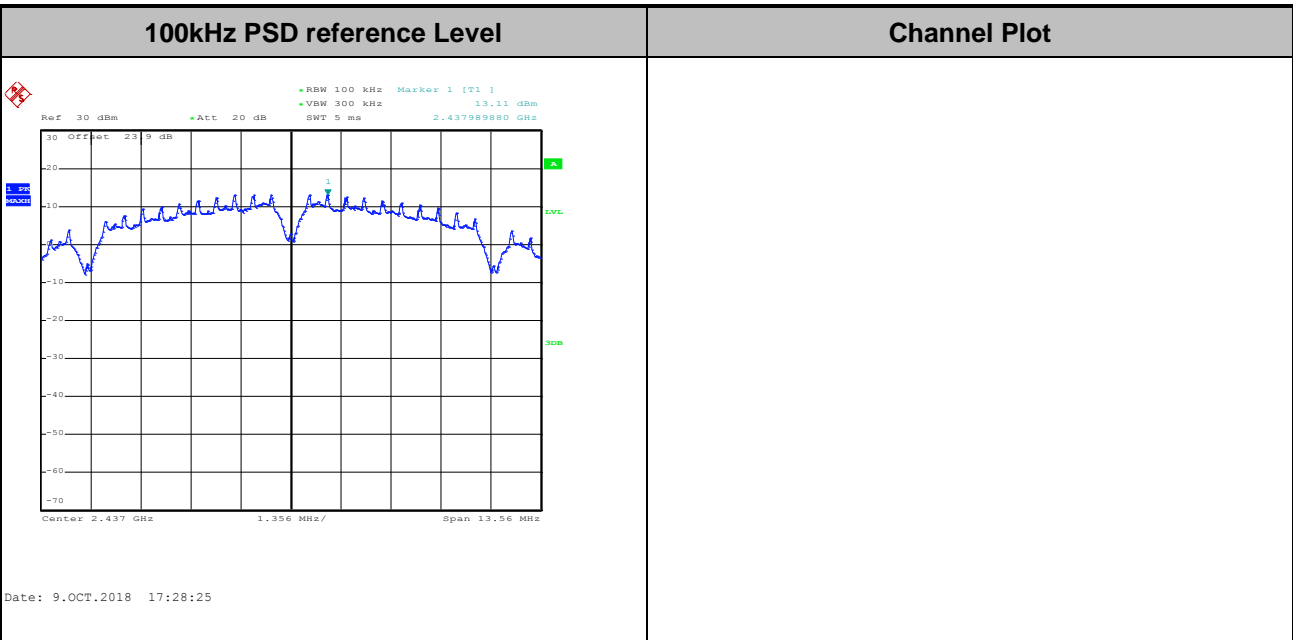



Test Mode :	802.11b	Test Channel :	11
-------------	---------	----------------	----

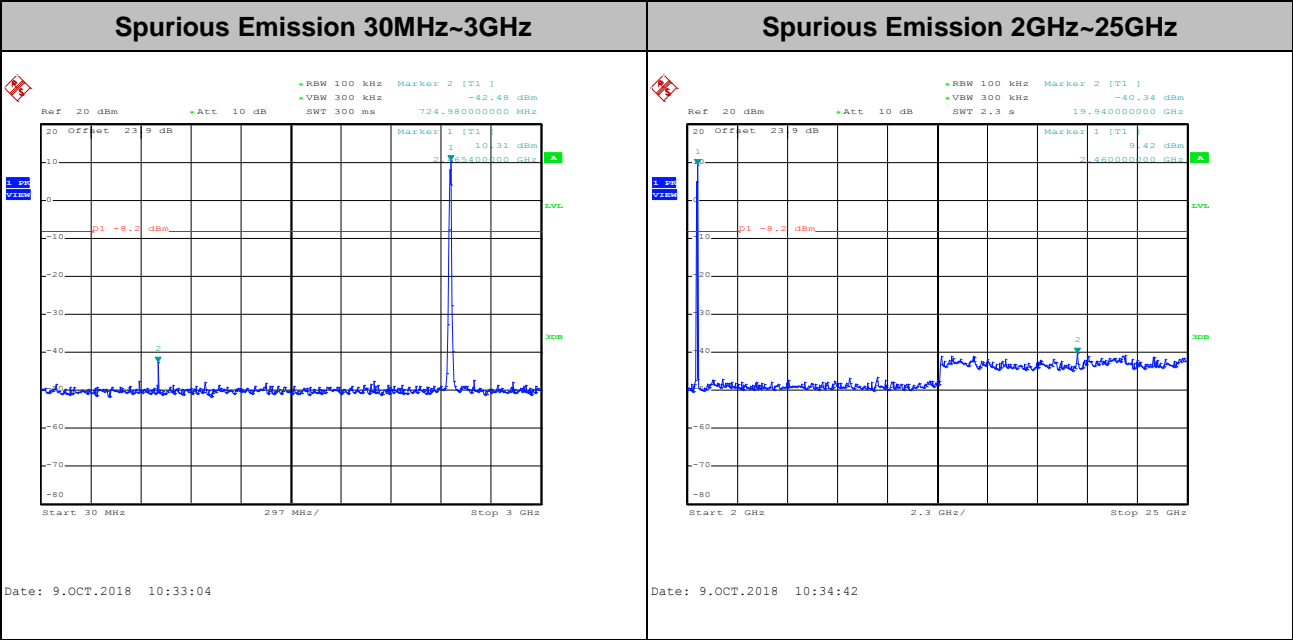
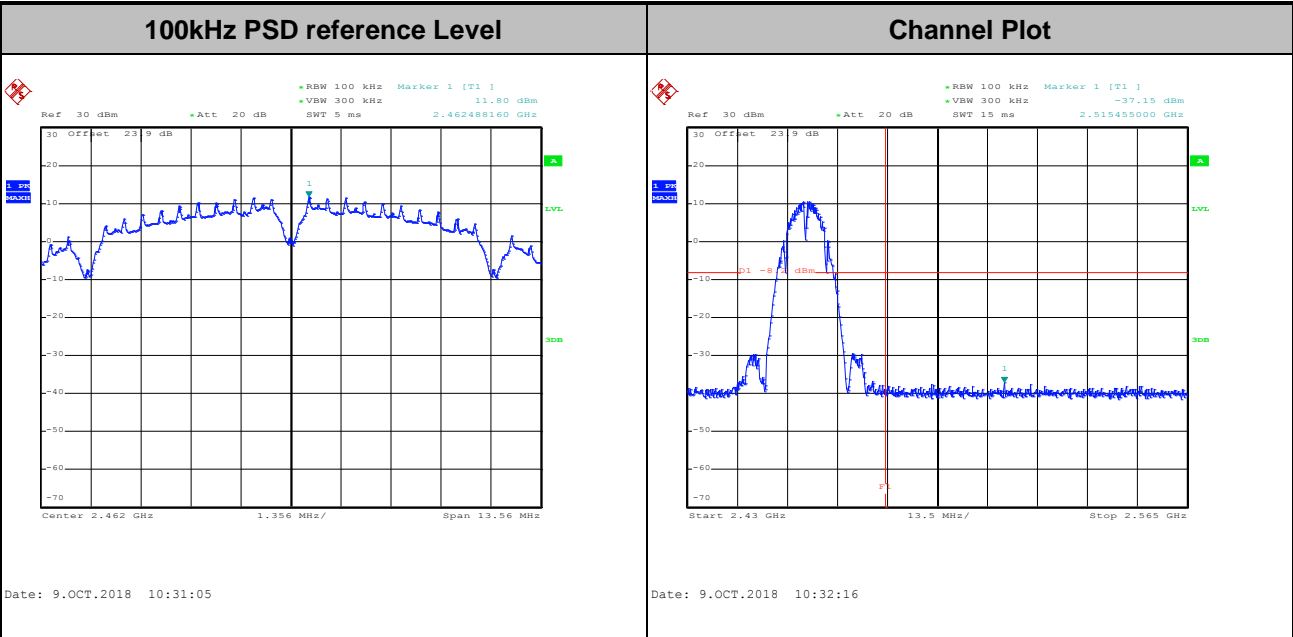



Test Mode :	802.11b	Test Channel :	12
-------------	---------	----------------	----

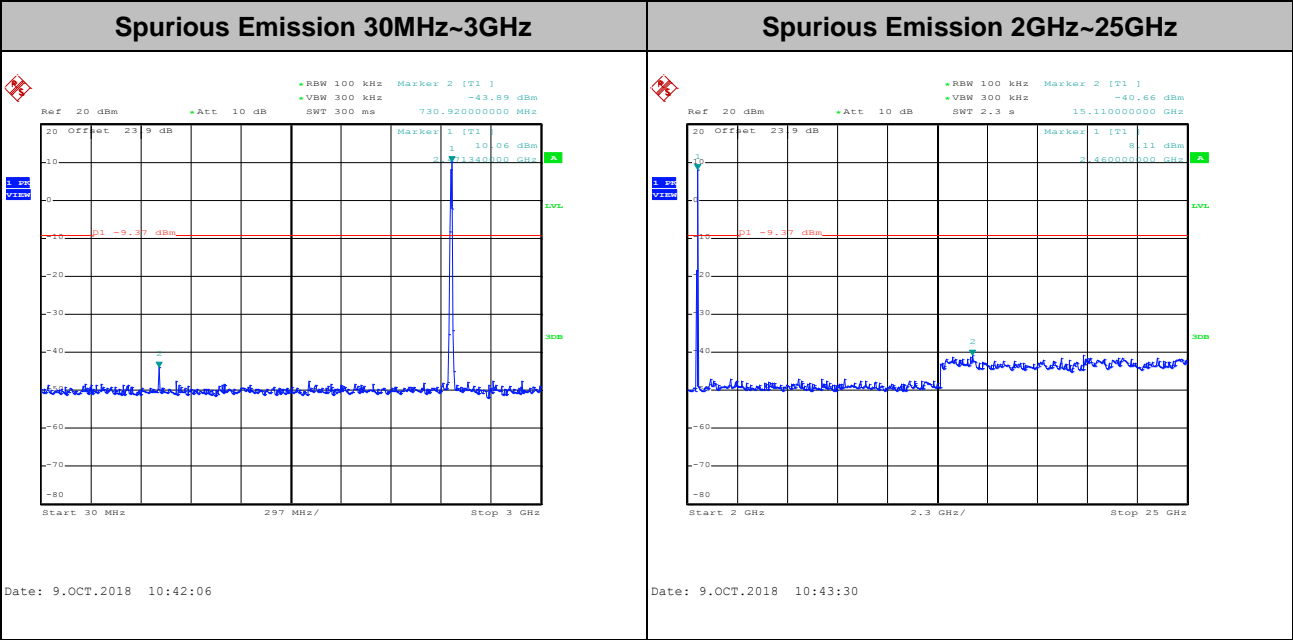
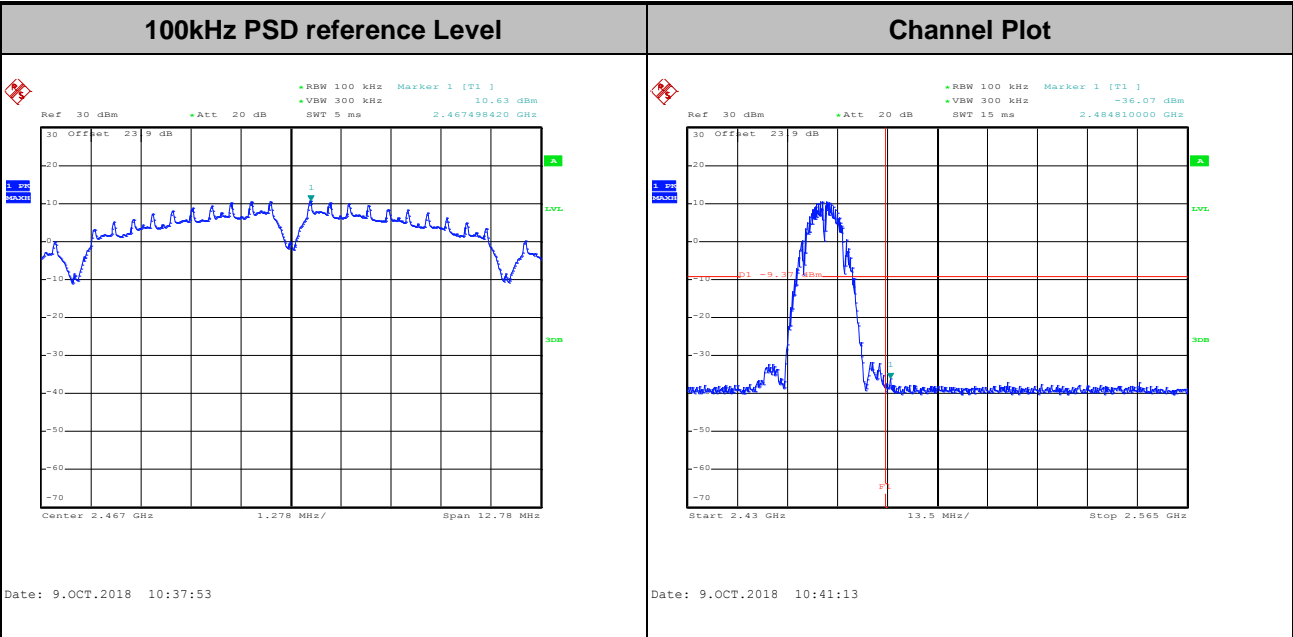



Test Mode :	802.11b	Test Channel :	13
-------------	---------	----------------	----

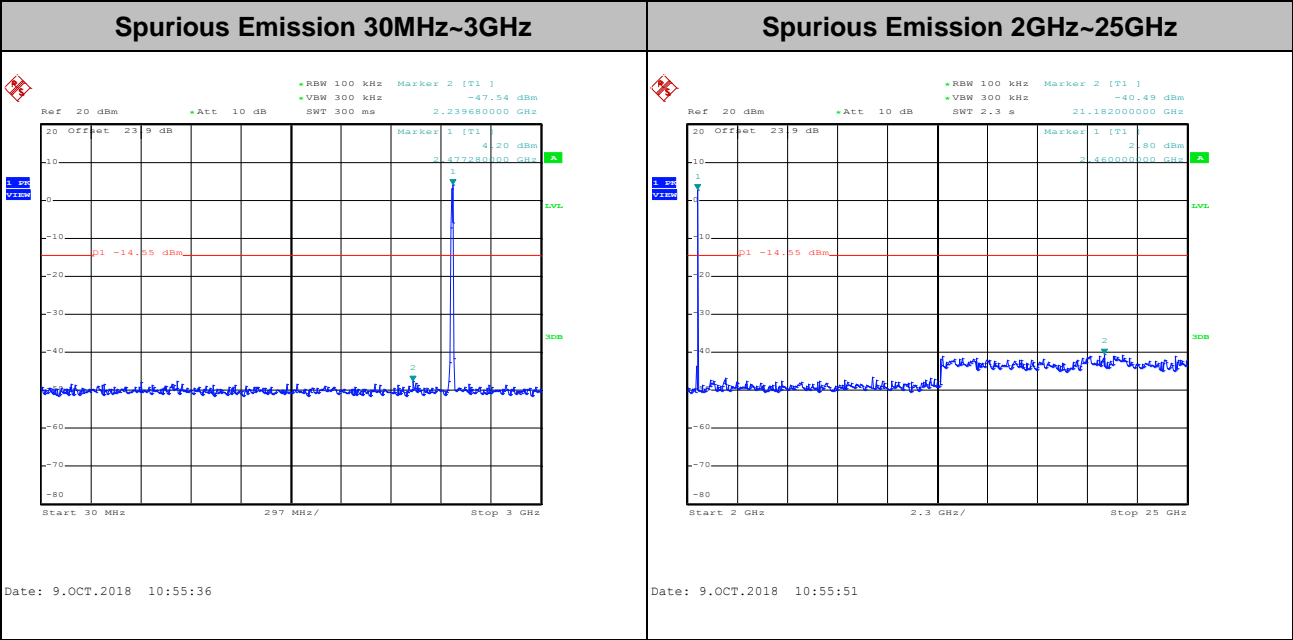
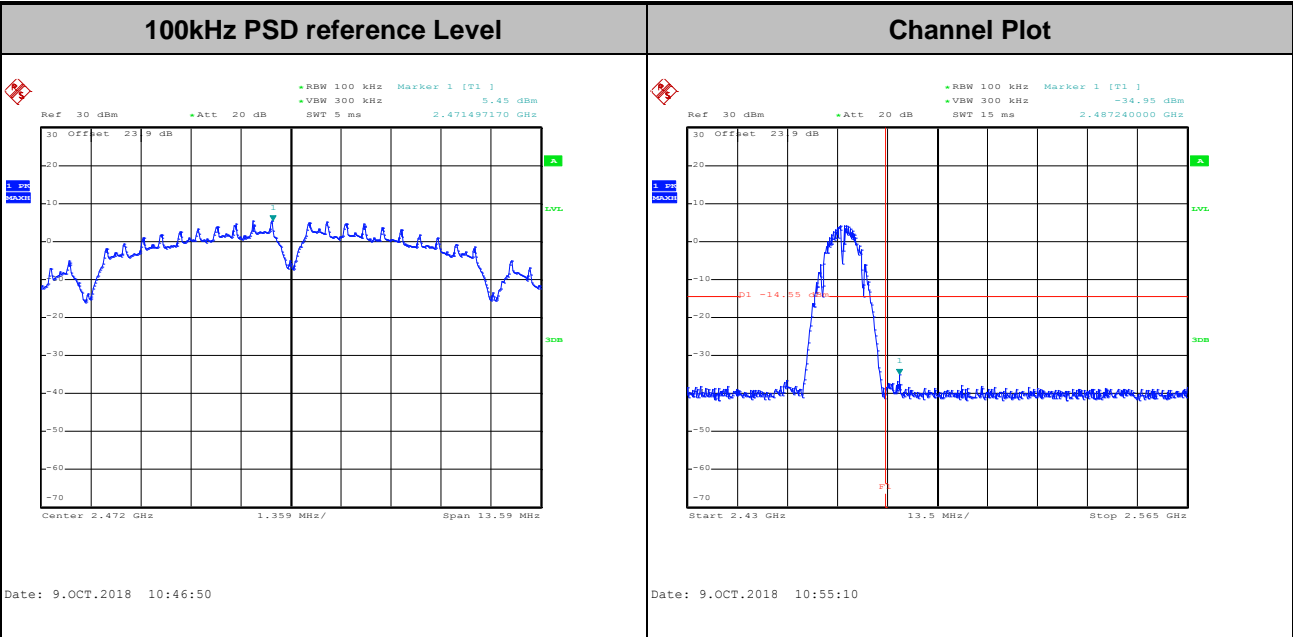



Test Mode :	802.11g	Test Channel :	01
-------------	---------	----------------	----

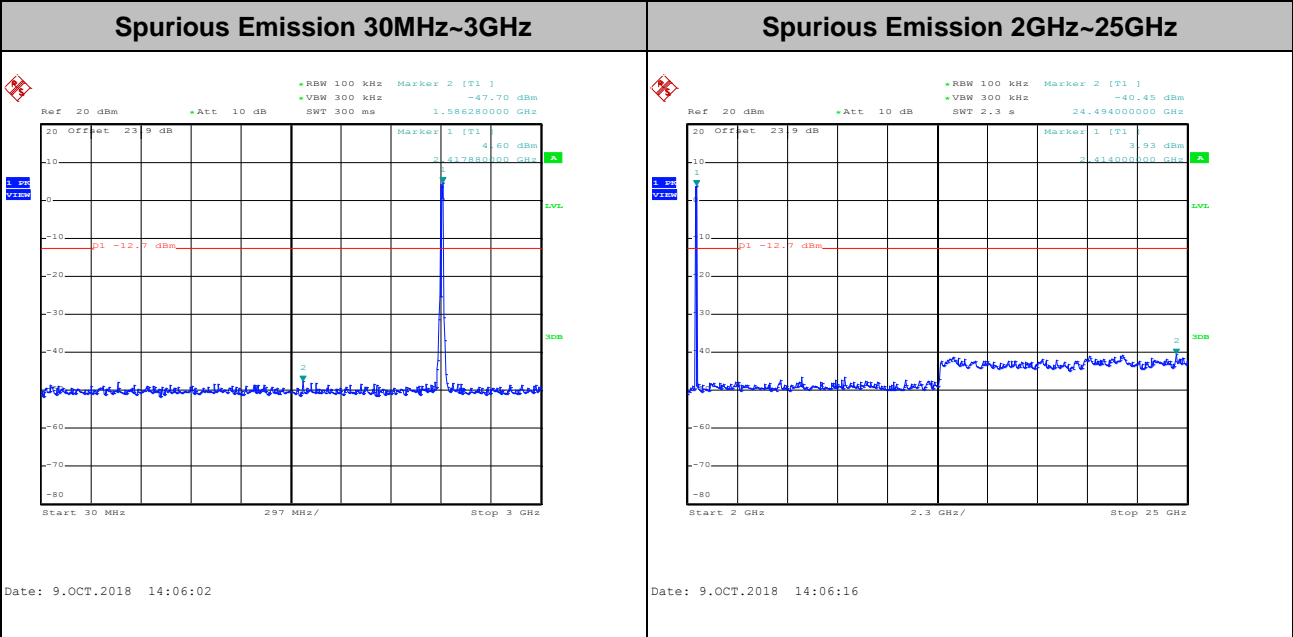
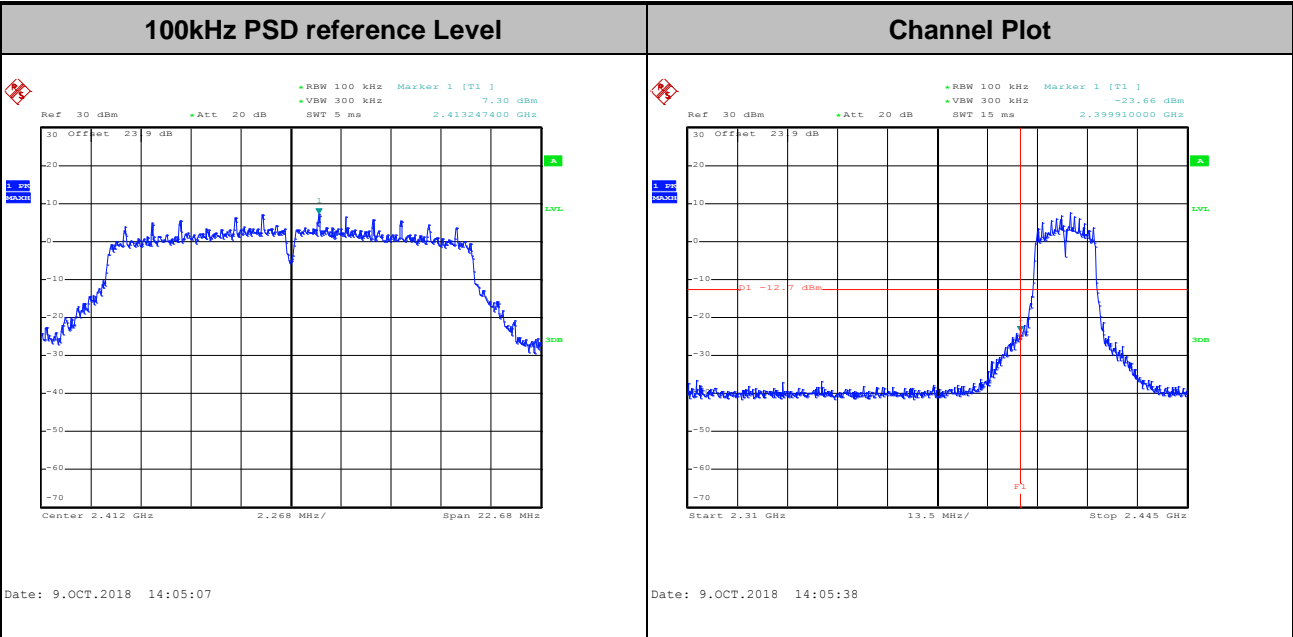



Test Mode :	802.11g	Test Channel :	06
-------------	---------	----------------	----

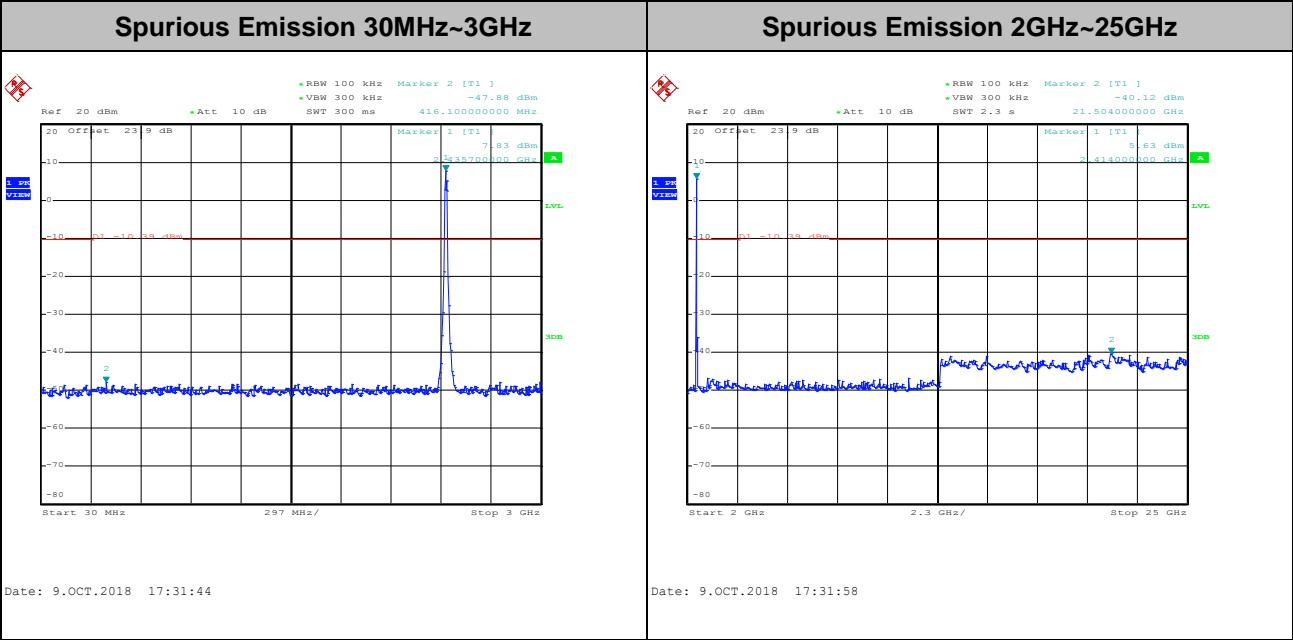
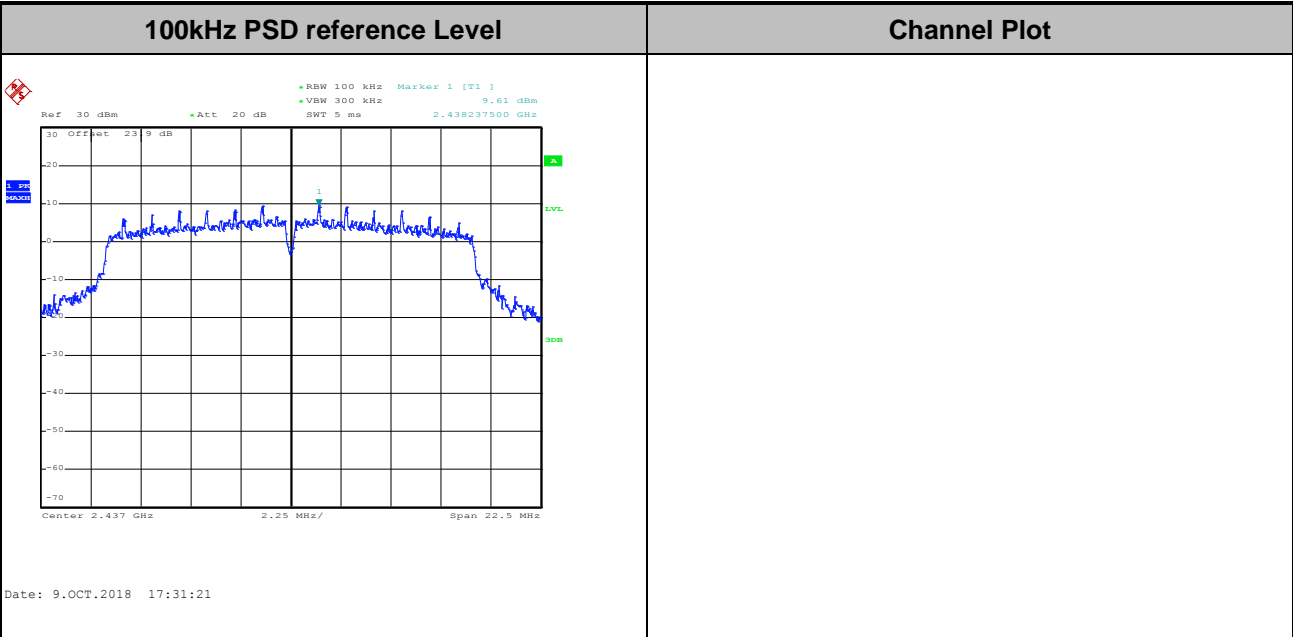



Test Mode :	802.11g	Test Channel :	11
-------------	---------	----------------	----

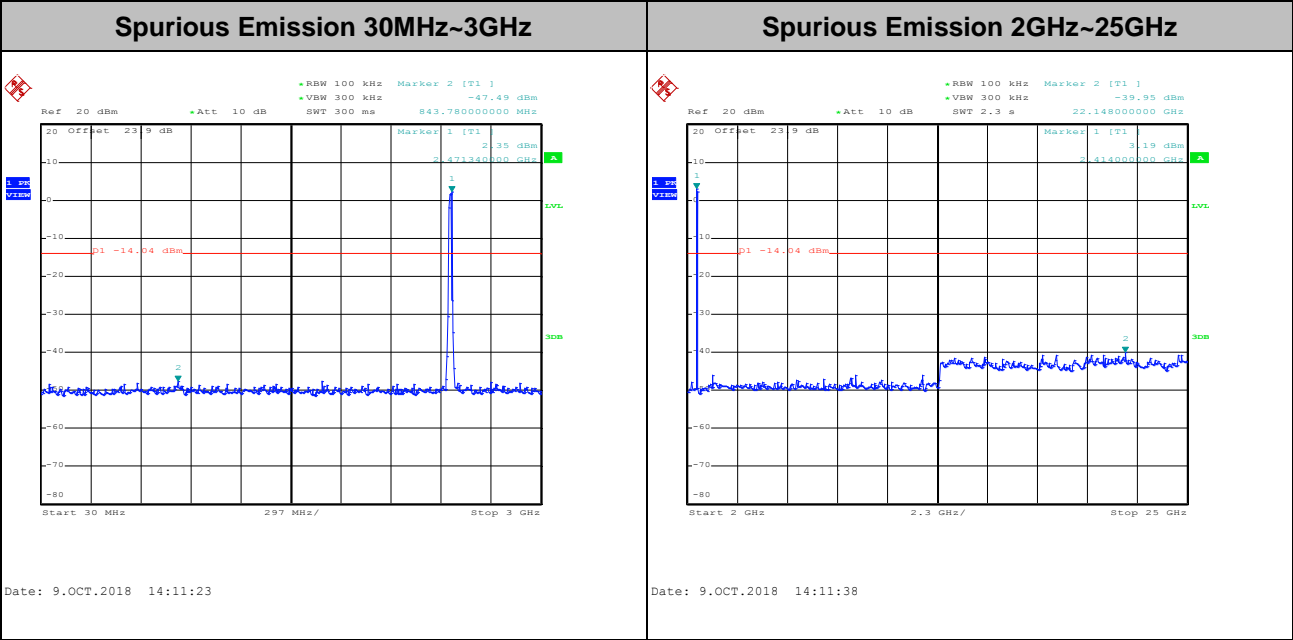
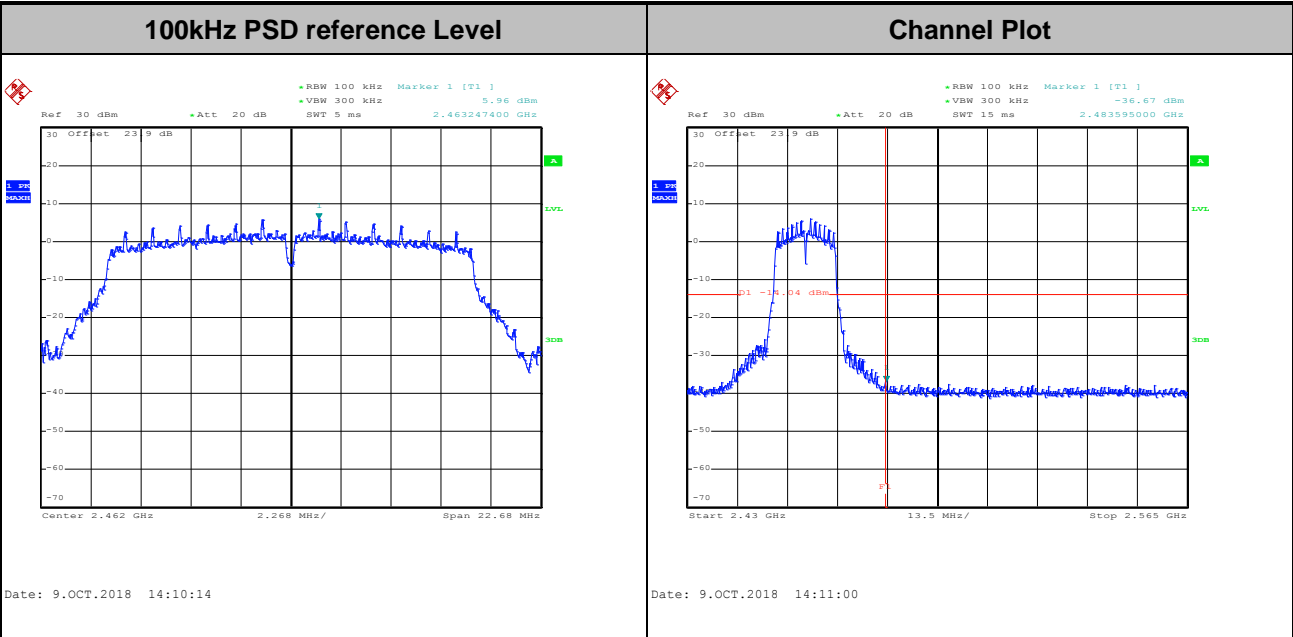



Test Mode :	802.11g	Test Channel :	12
-------------	---------	----------------	----

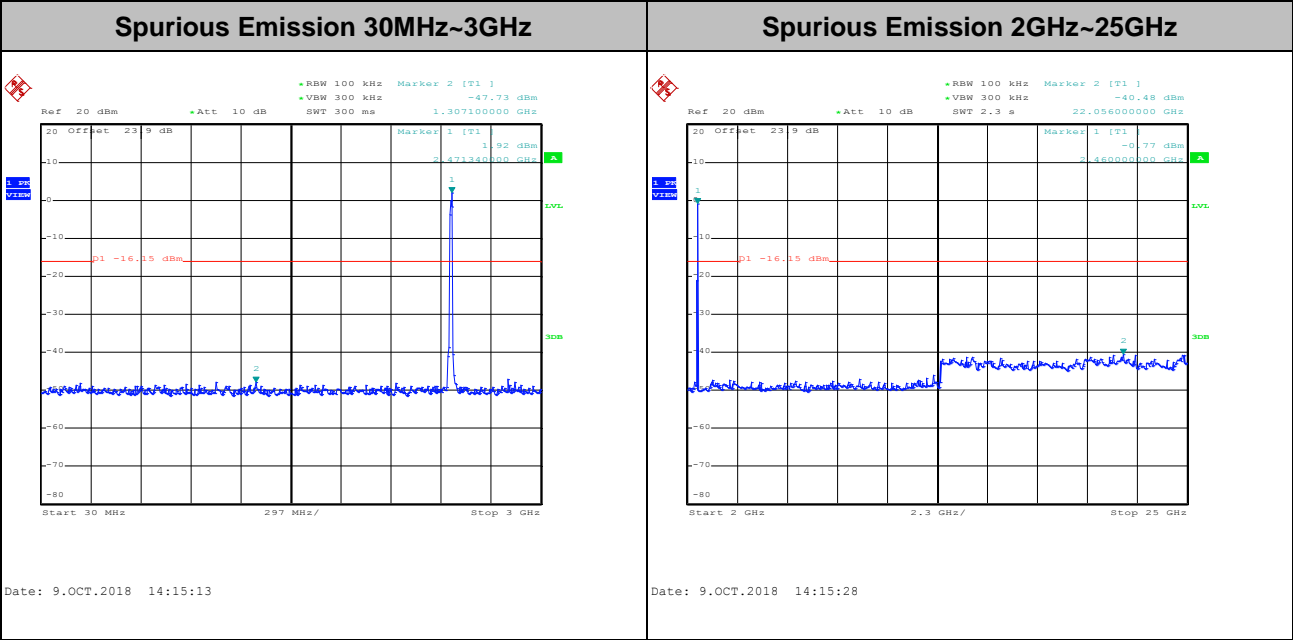
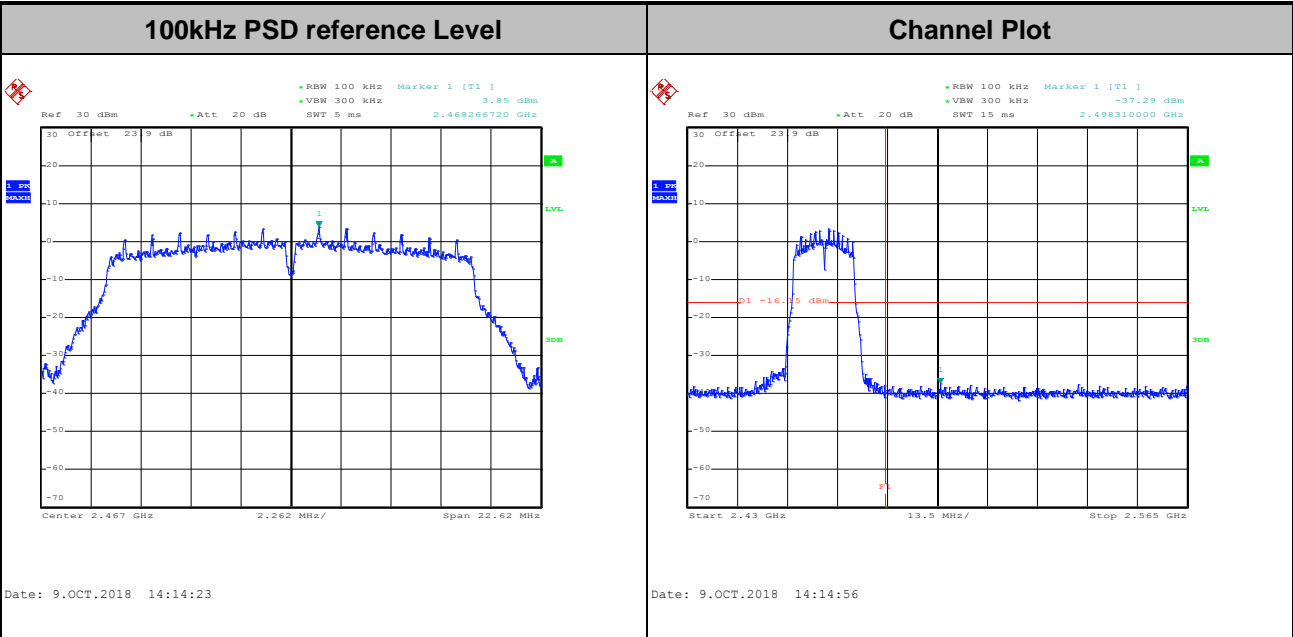



Test Mode :	802.11g	Test Channel :	13
-------------	---------	----------------	----

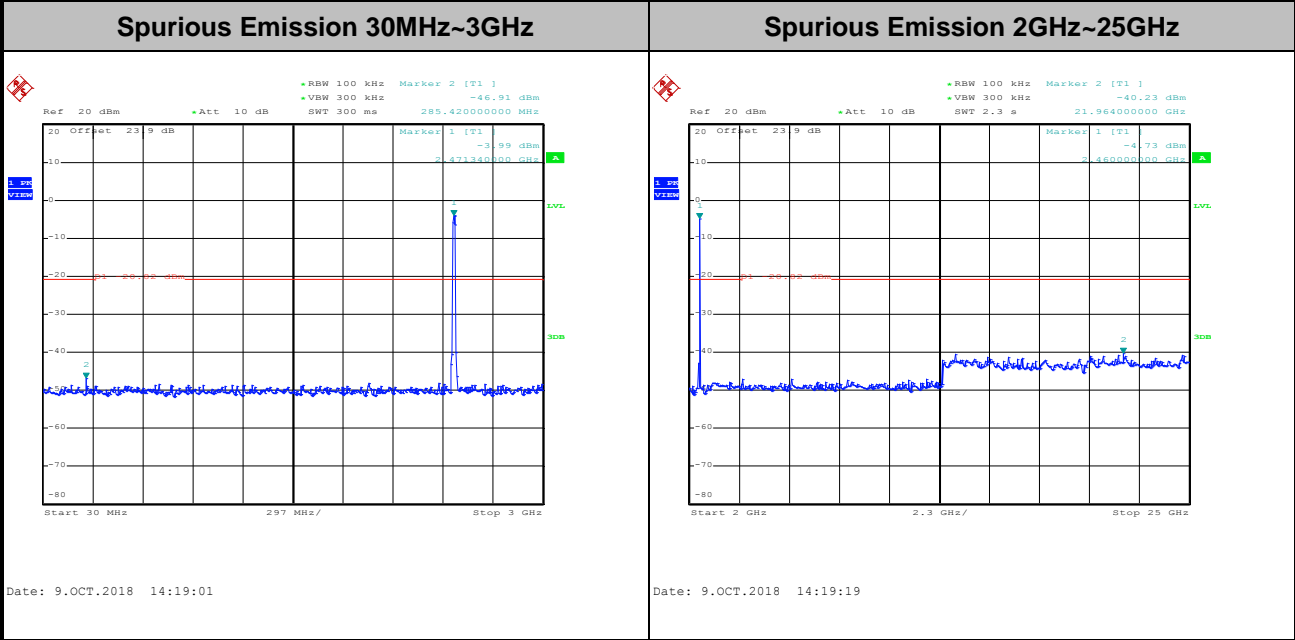
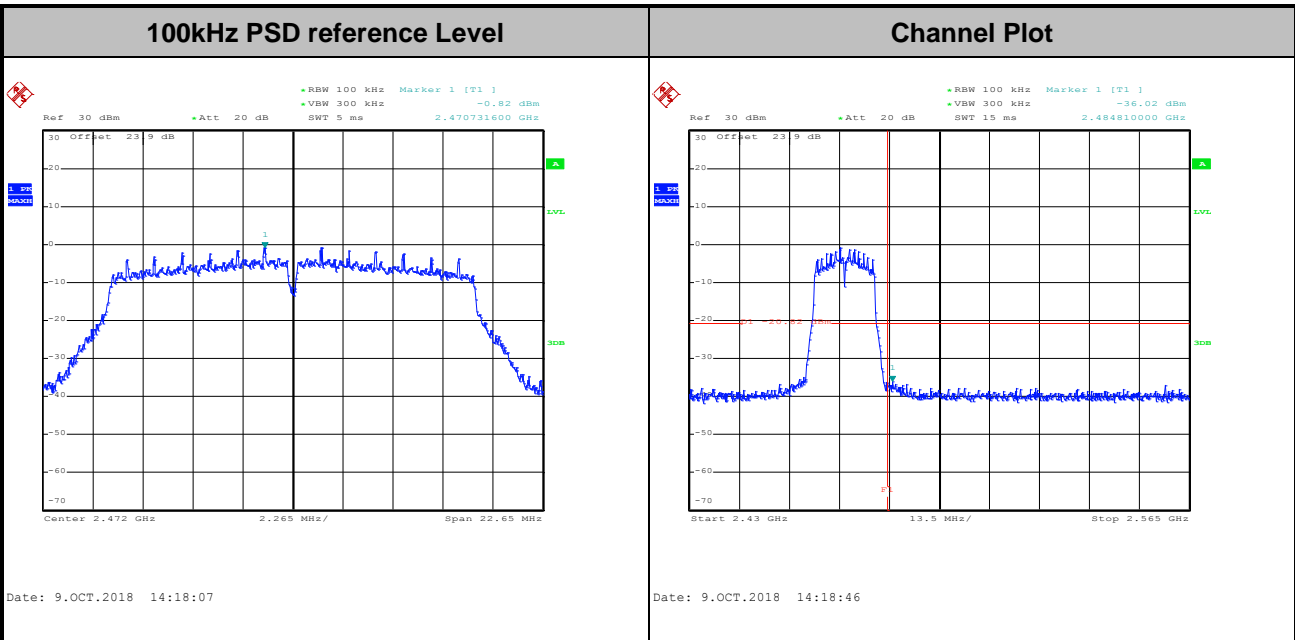



Test Mode : 802.11n HT20 Test Channel : 01

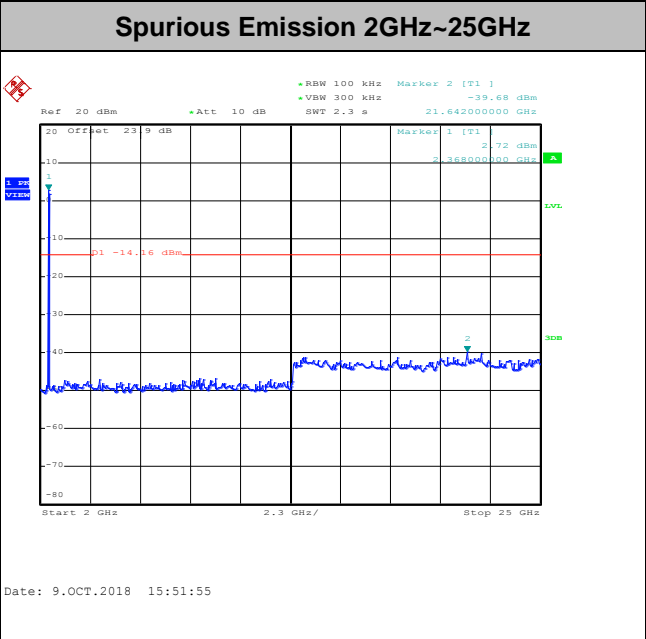
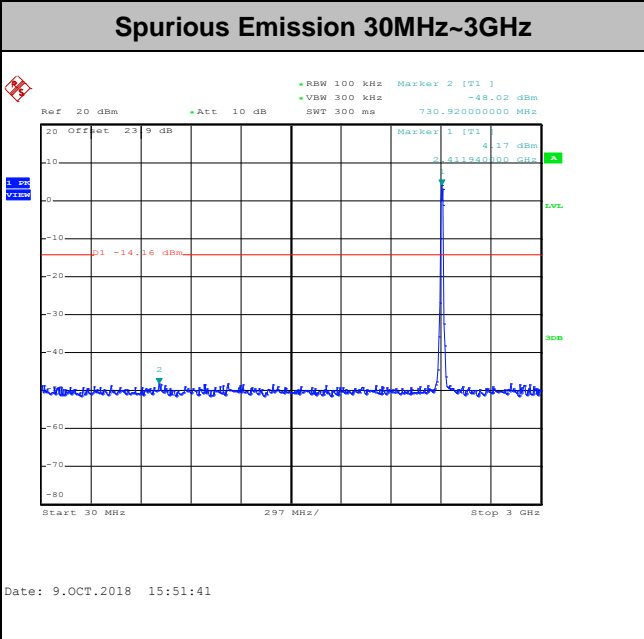
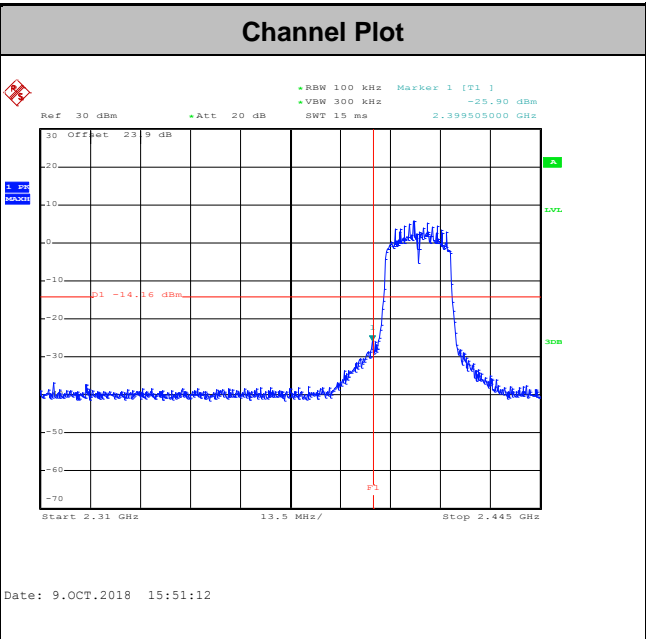
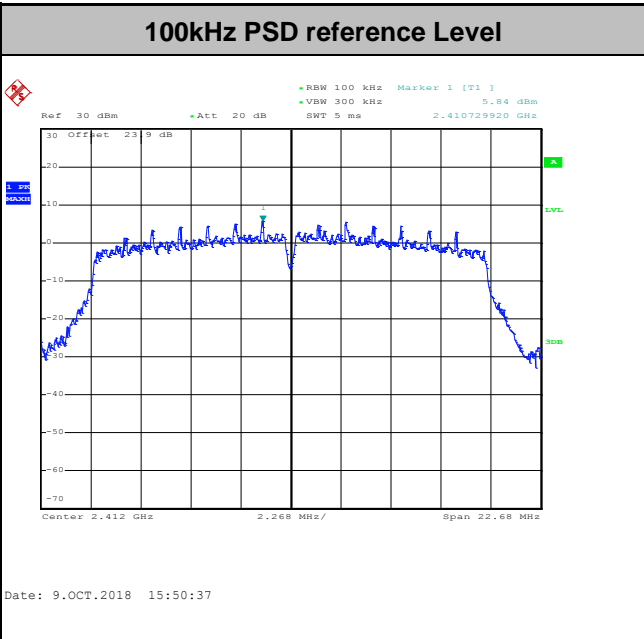



Test Mode :	802.11n HT20	Test Channel :	06
-------------	--------------	----------------	----

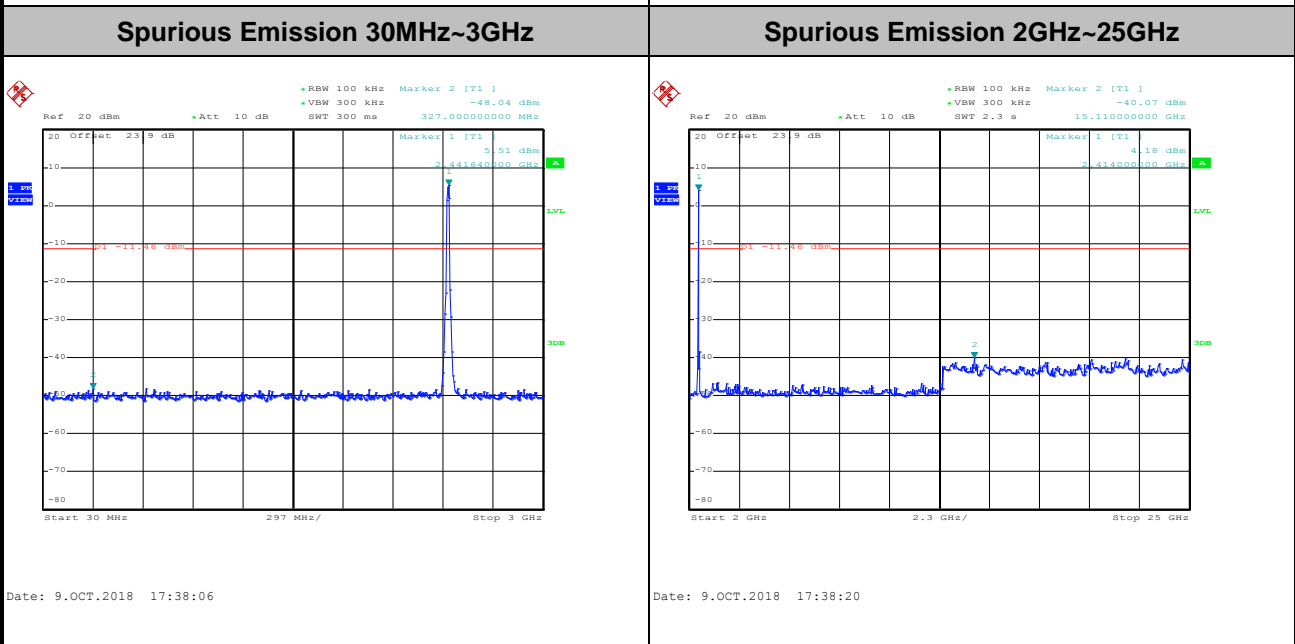
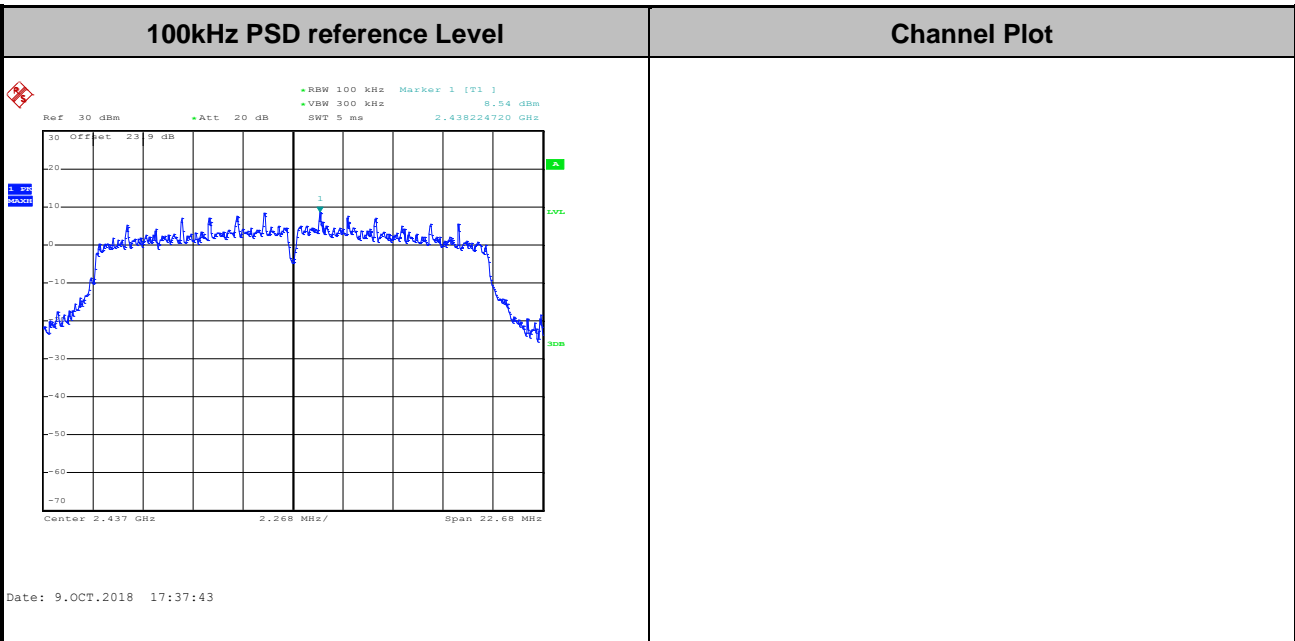



Test Mode :	802.11n HT20	Test Channel :	11
-------------	--------------	----------------	----

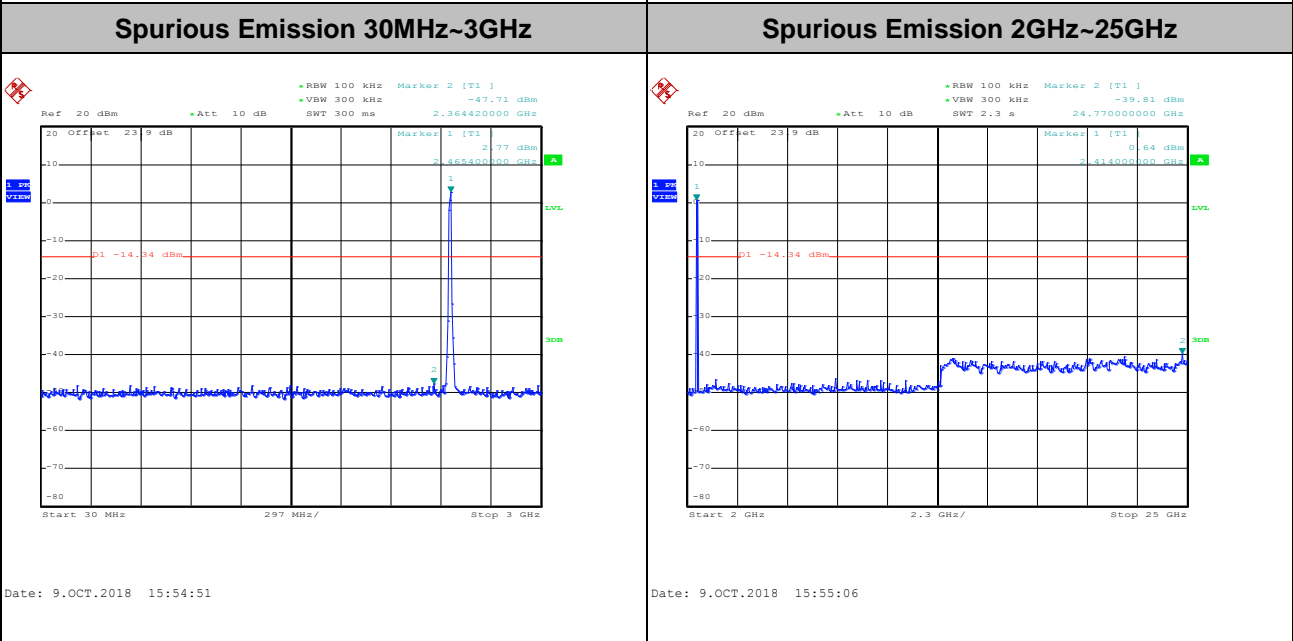
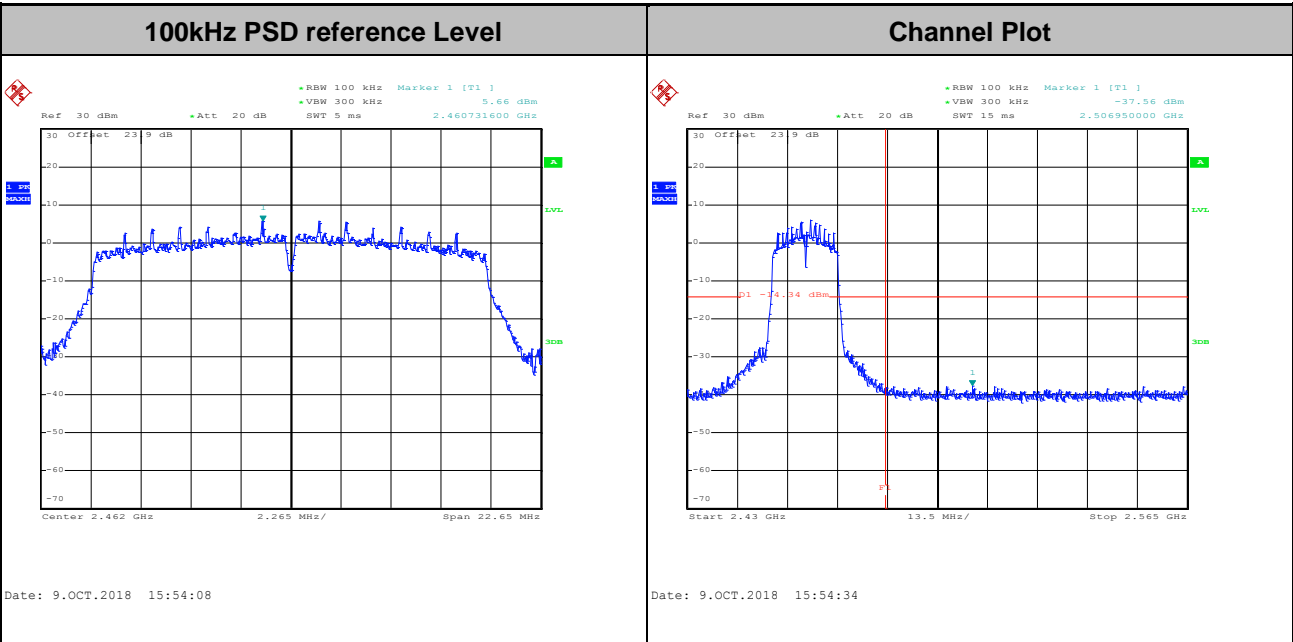



Test Mode :	802.11n HT20	Test Channel :	12
-------------	--------------	----------------	----

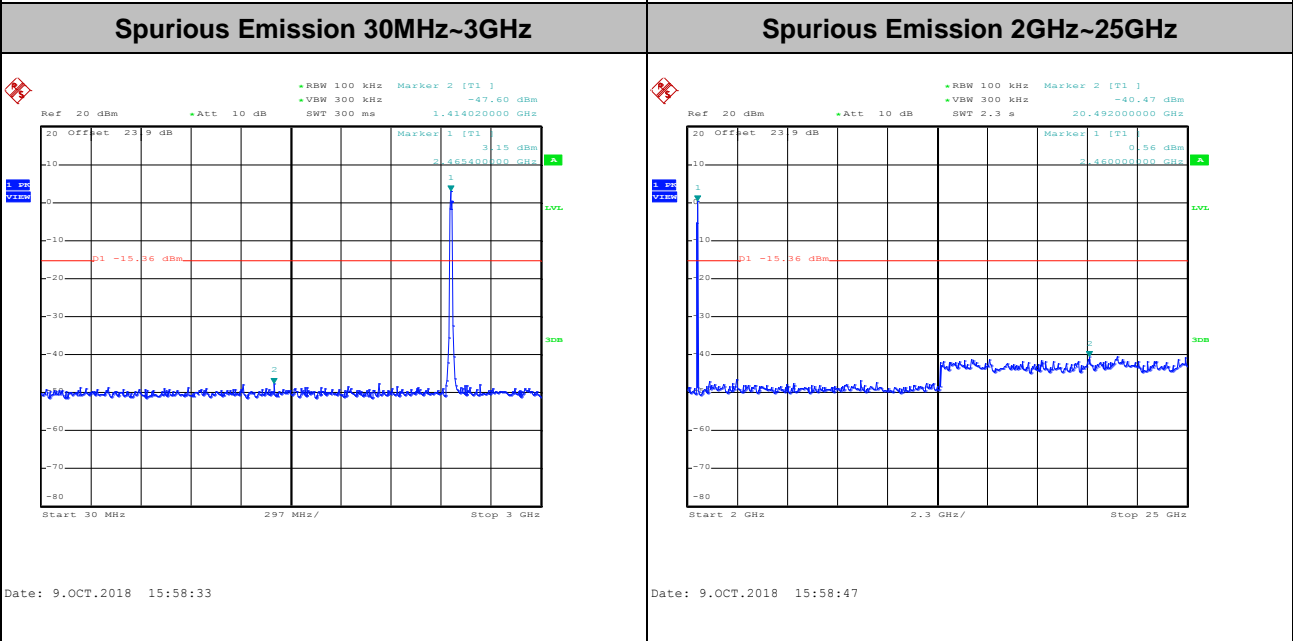
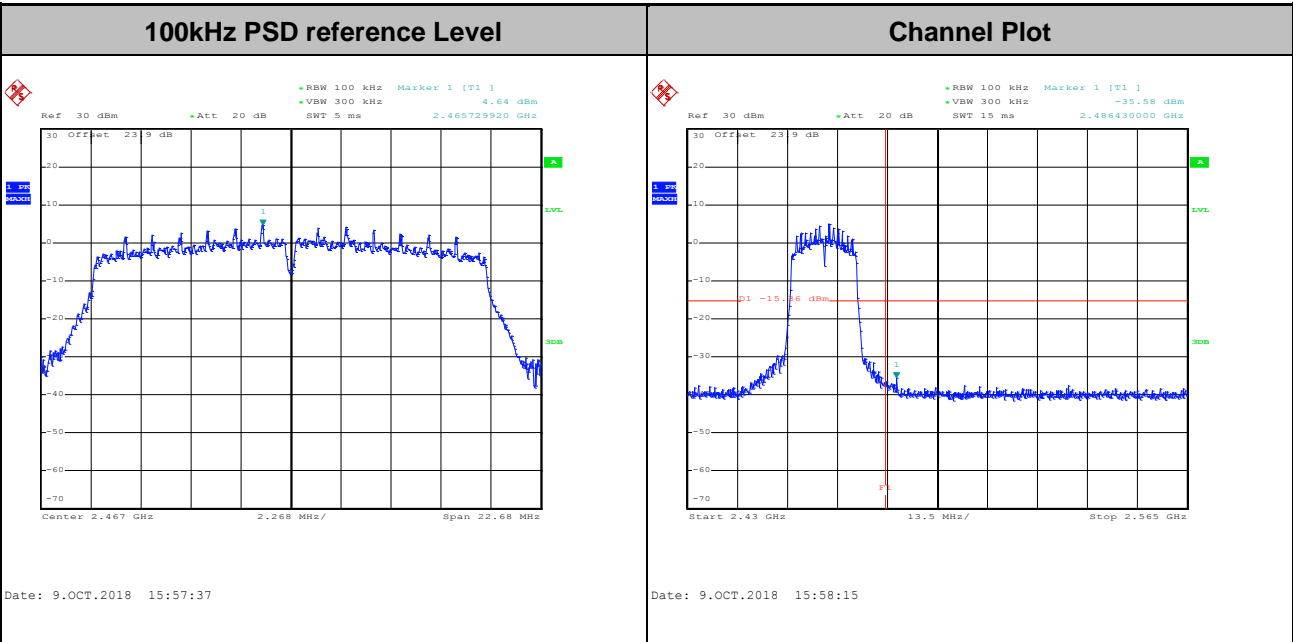



Test Mode :	802.11n HT20	Test Channel :	13
-------------	--------------	----------------	----

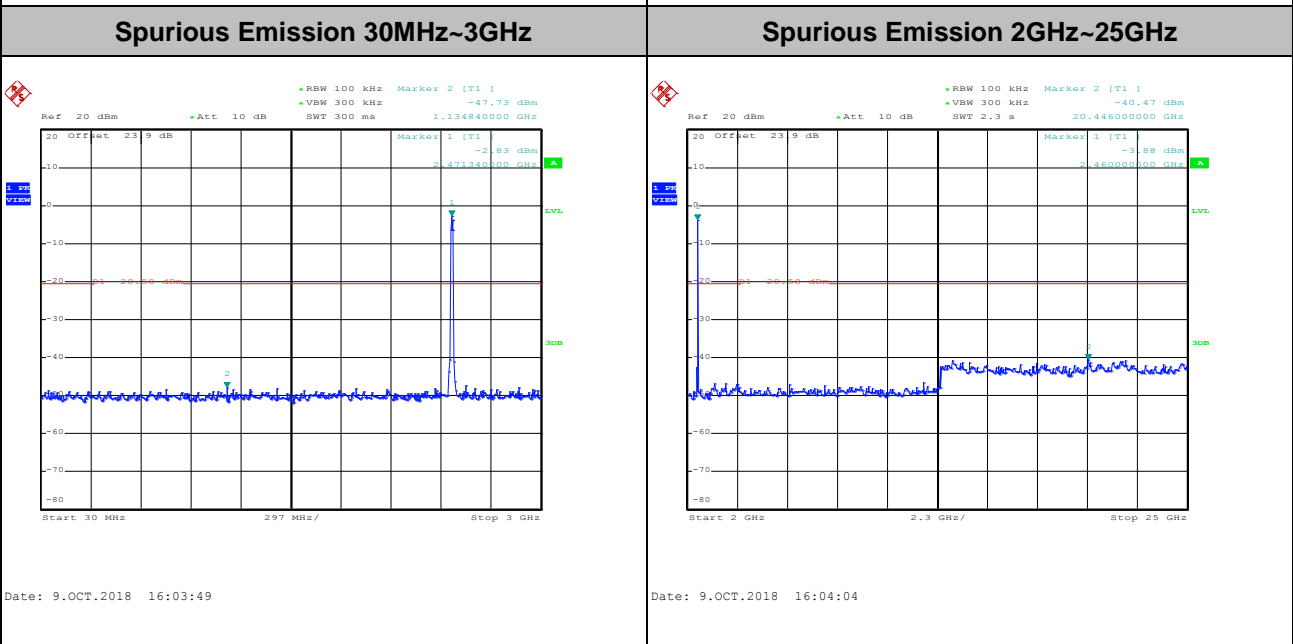
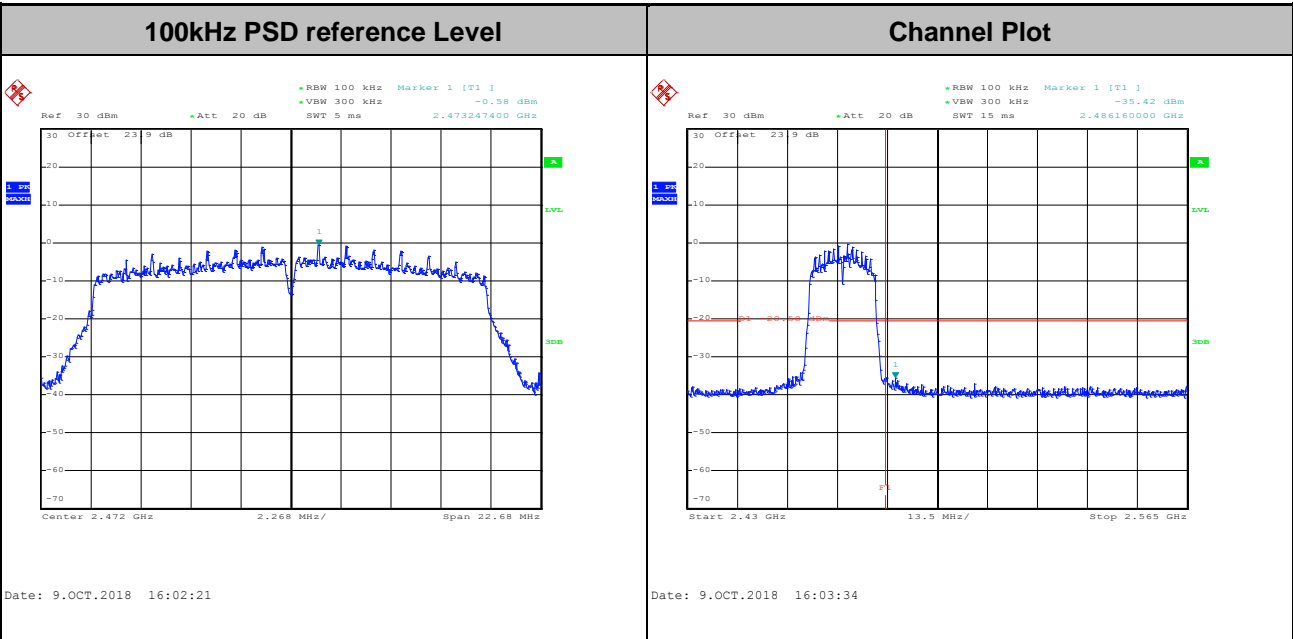



Number of TX = 2, Ant. 1 (Measured)

Test Mode :	802.11b	Test Channel :	01
-------------	---------	----------------	----

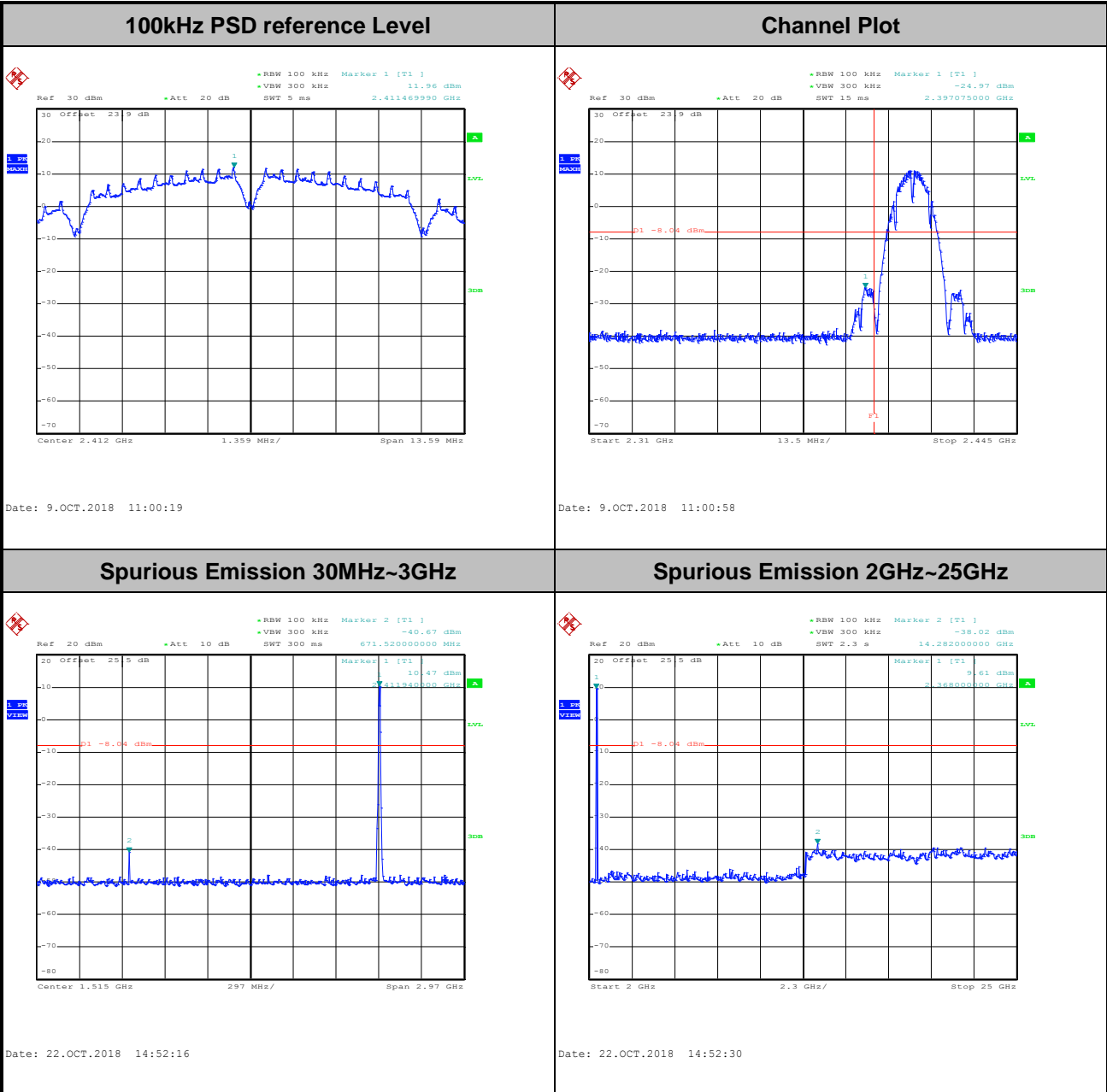



Test Mode :	802.11b	Test Channel :	06
-------------	---------	----------------	----

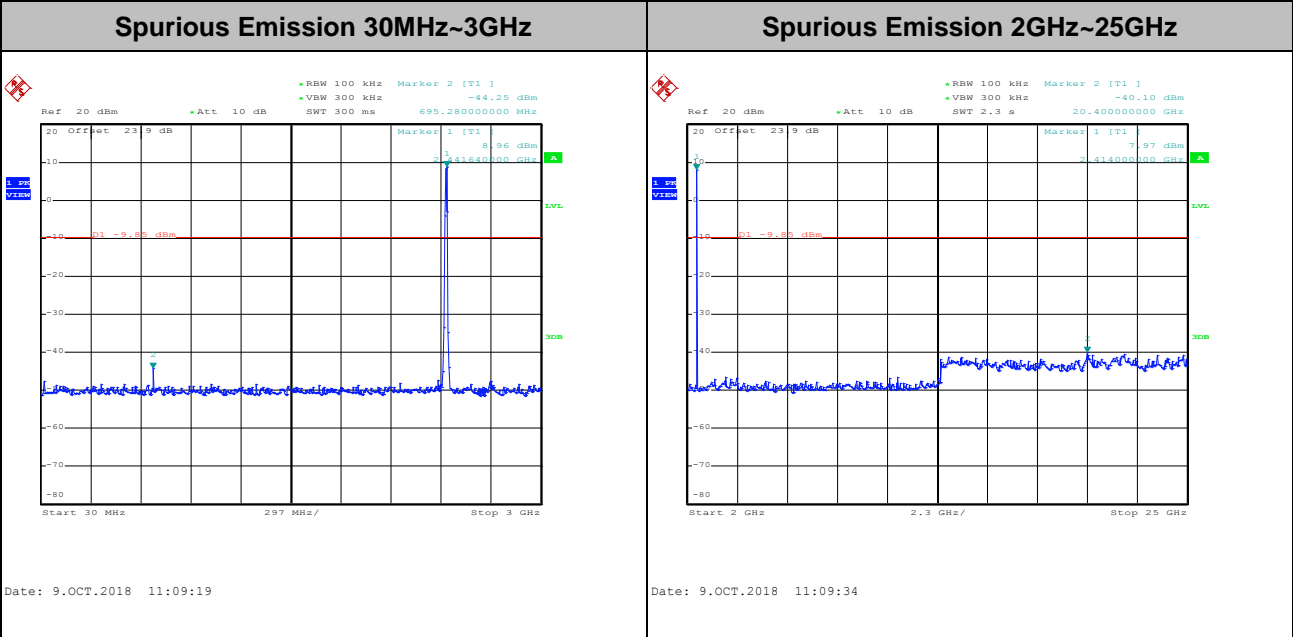
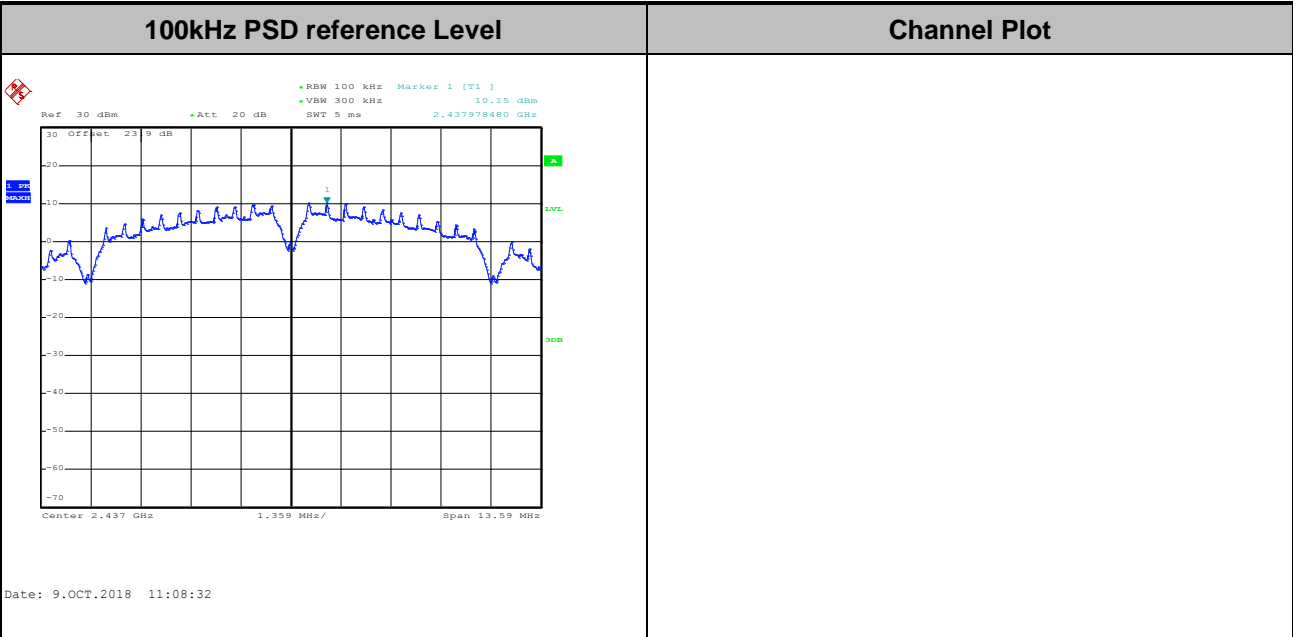



Test Mode :	802.11b	Test Channel :	11
-------------	---------	----------------	----

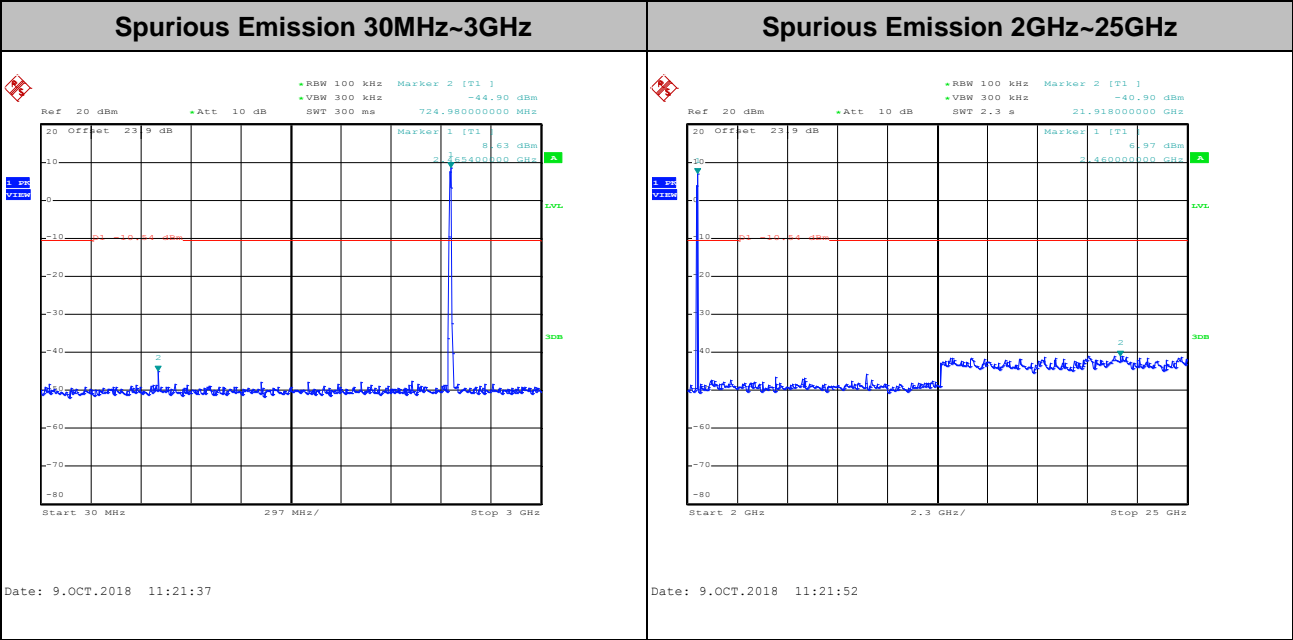
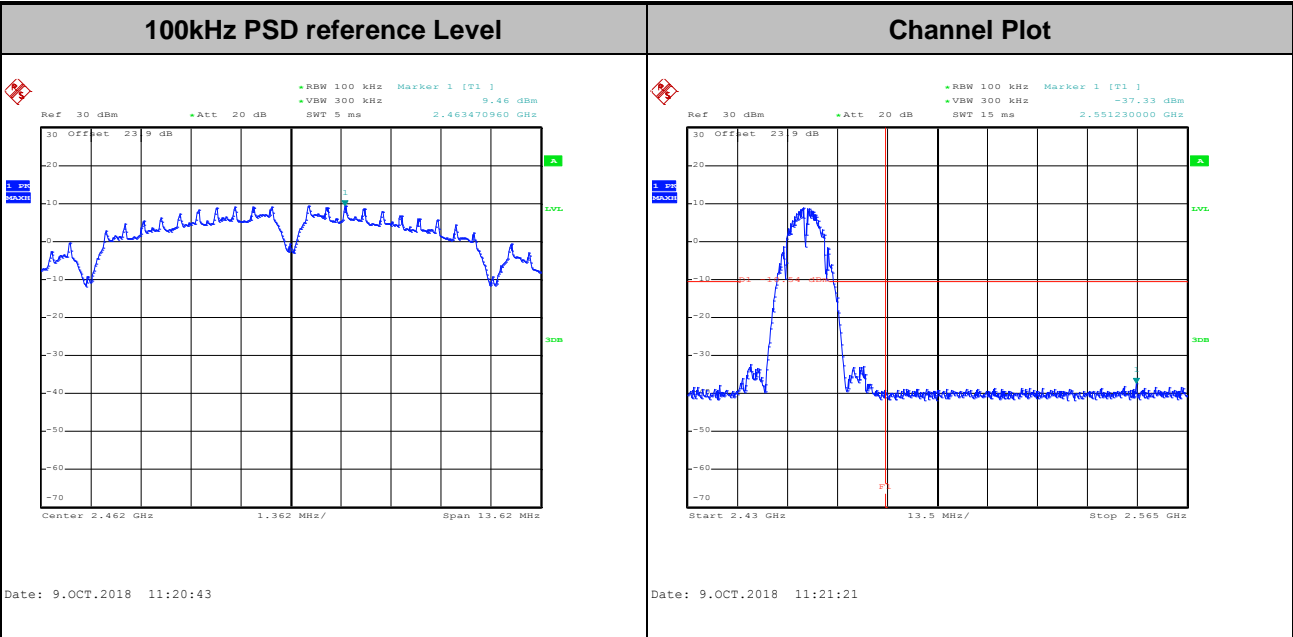



Test Mode :	802.11b	Test Channel :	12
-------------	---------	----------------	----

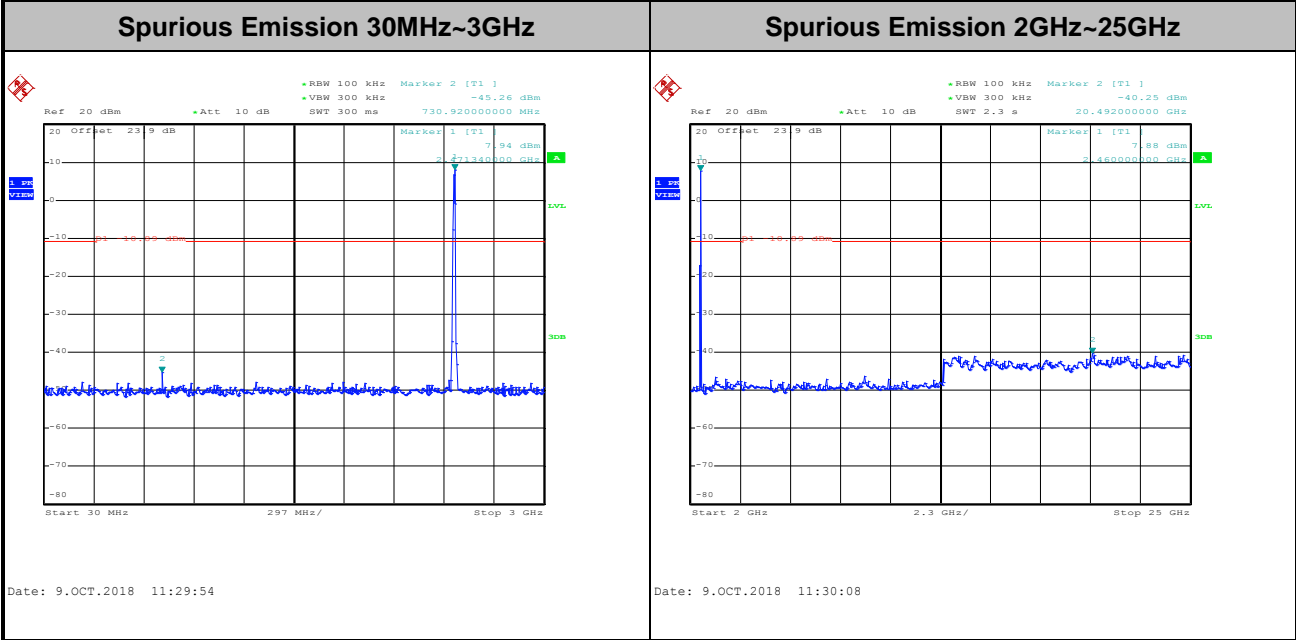
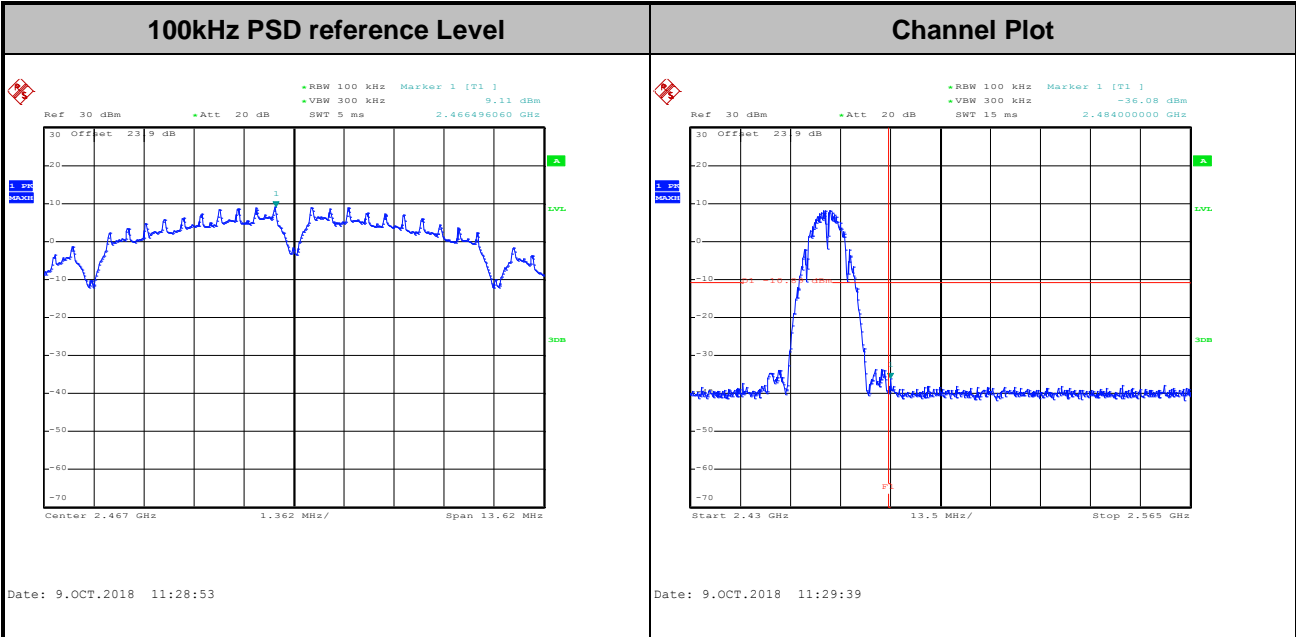



Test Mode :	802.11b	Test Channel :	13
-------------	---------	----------------	----

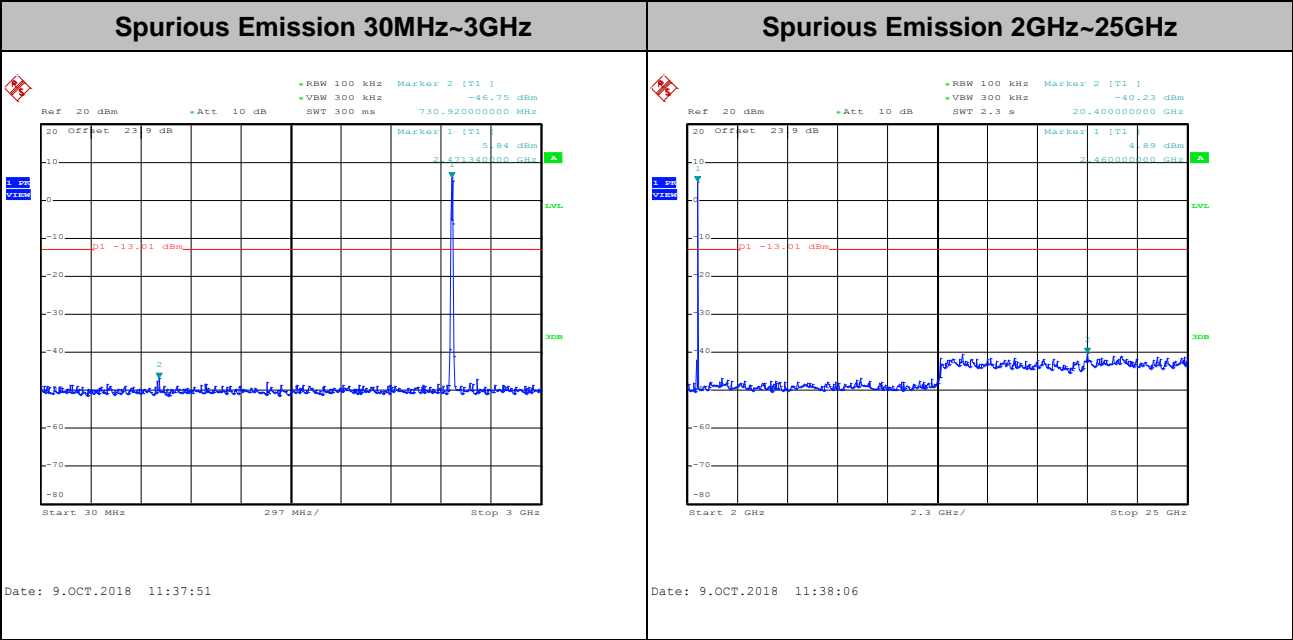
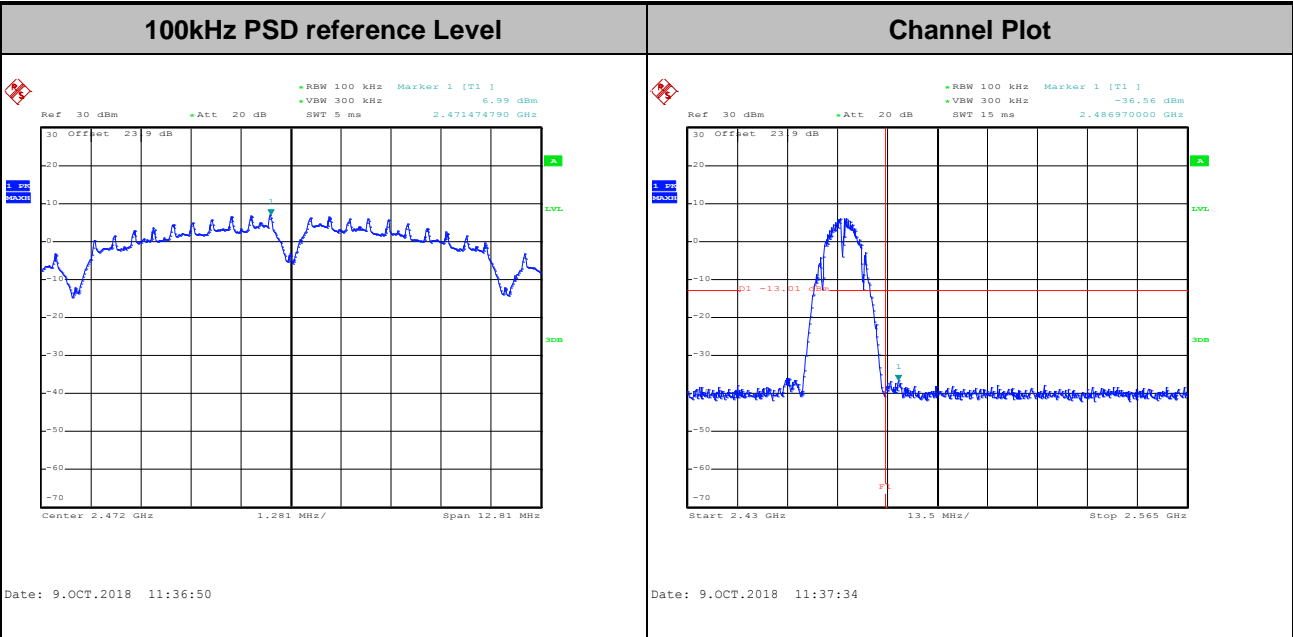



Test Mode :	802.11g	Test Channel :	01
-------------	---------	----------------	----

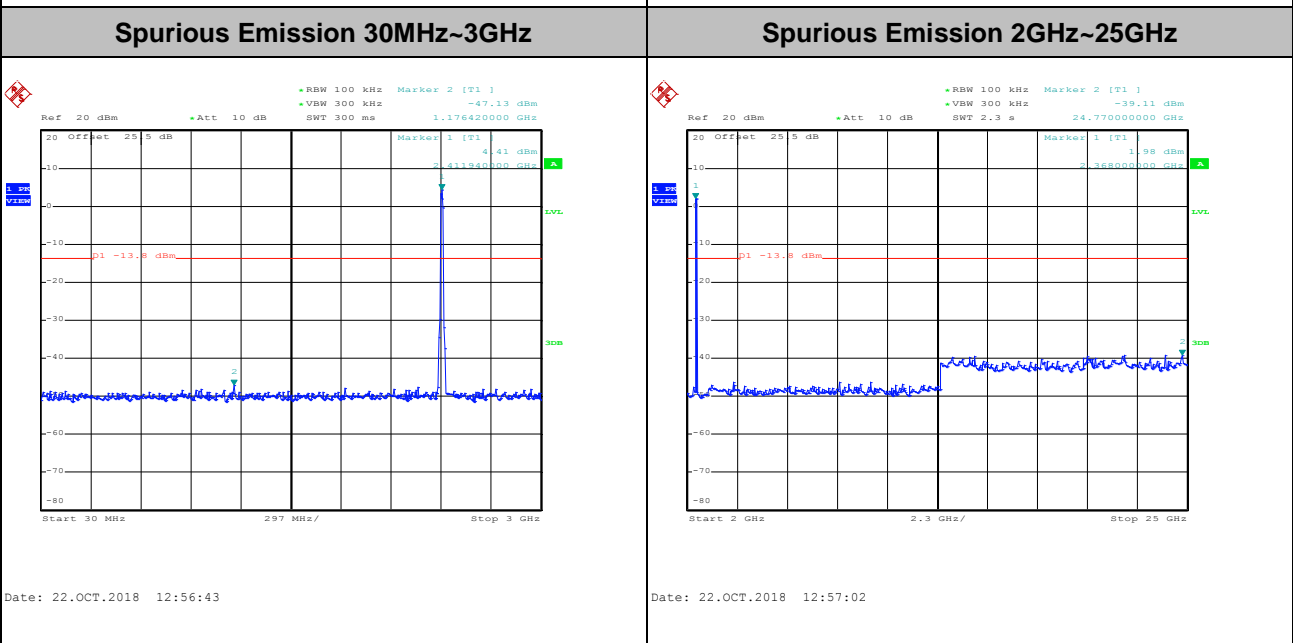
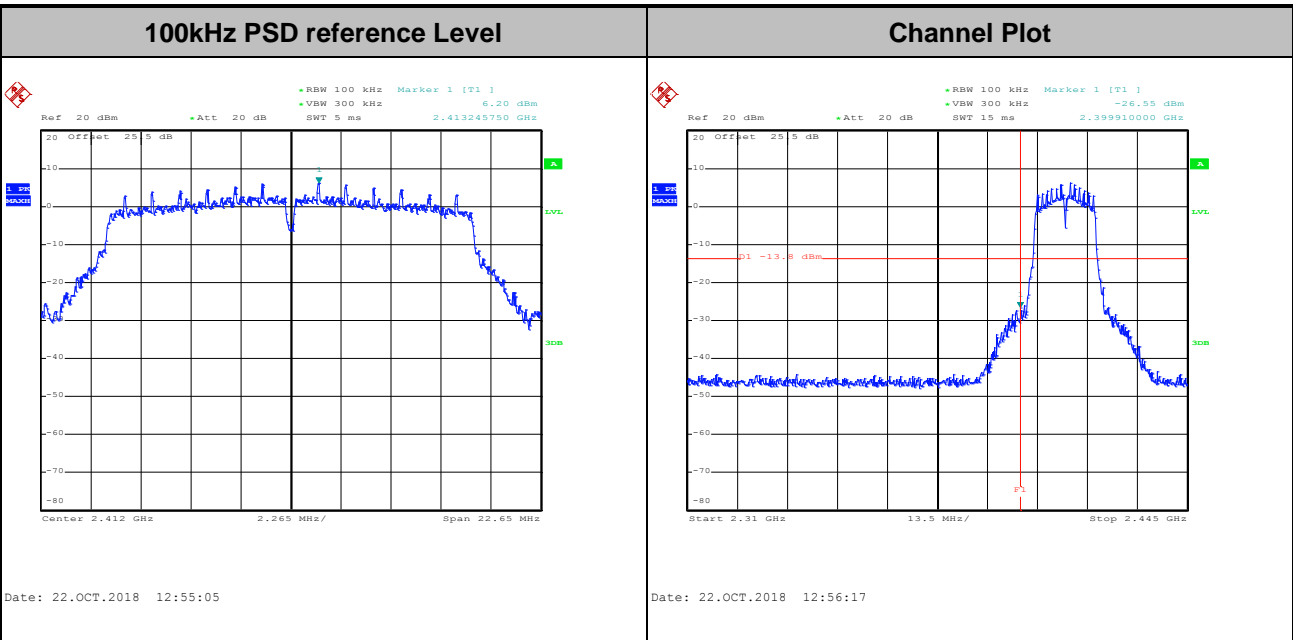



Test Mode :	802.11g	Test Channel :	06
-------------	---------	----------------	----

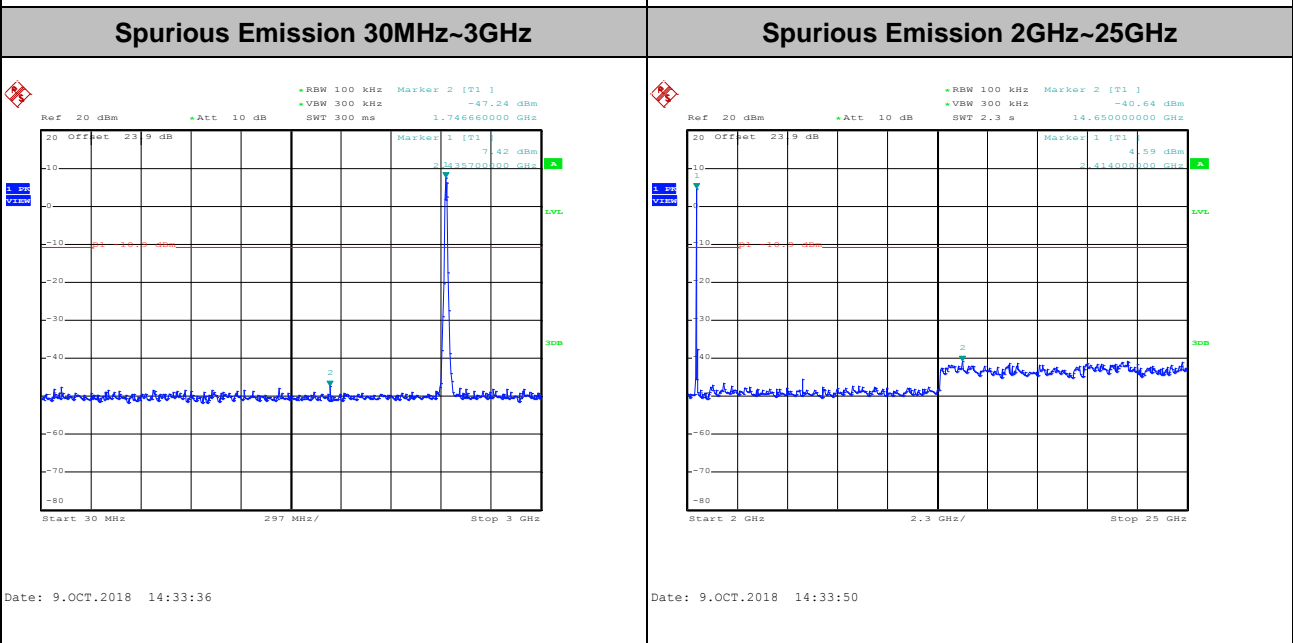
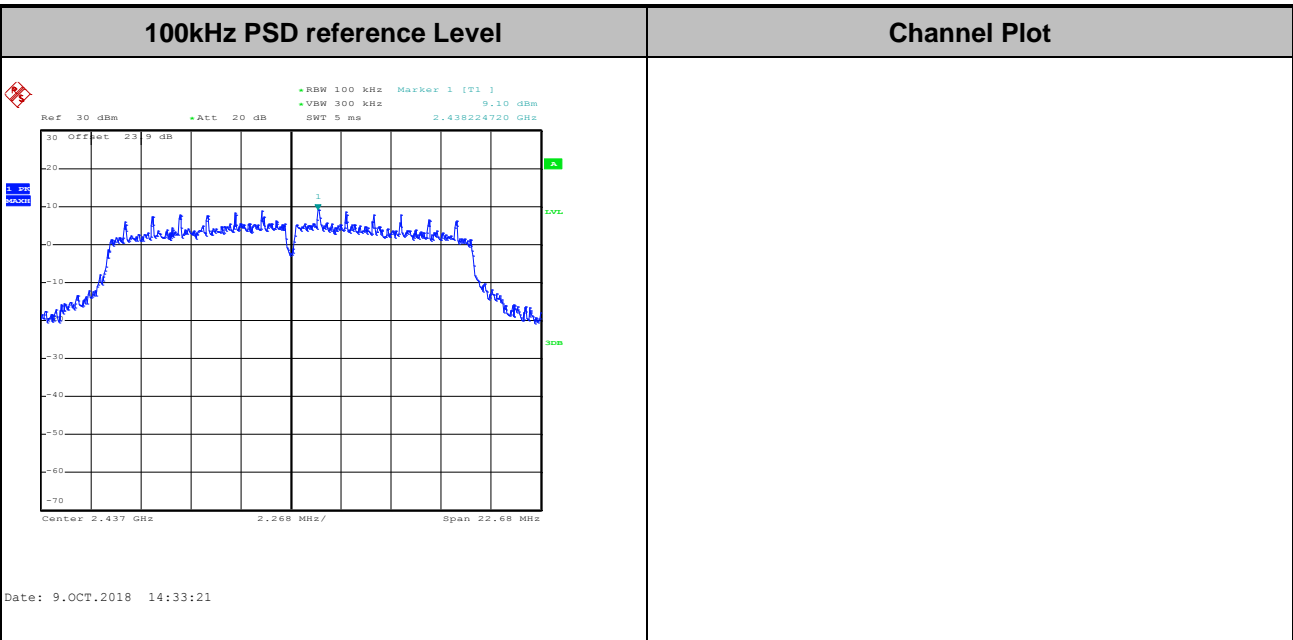



Test Mode :	802.11g	Test Channel :	11
-------------	---------	----------------	----

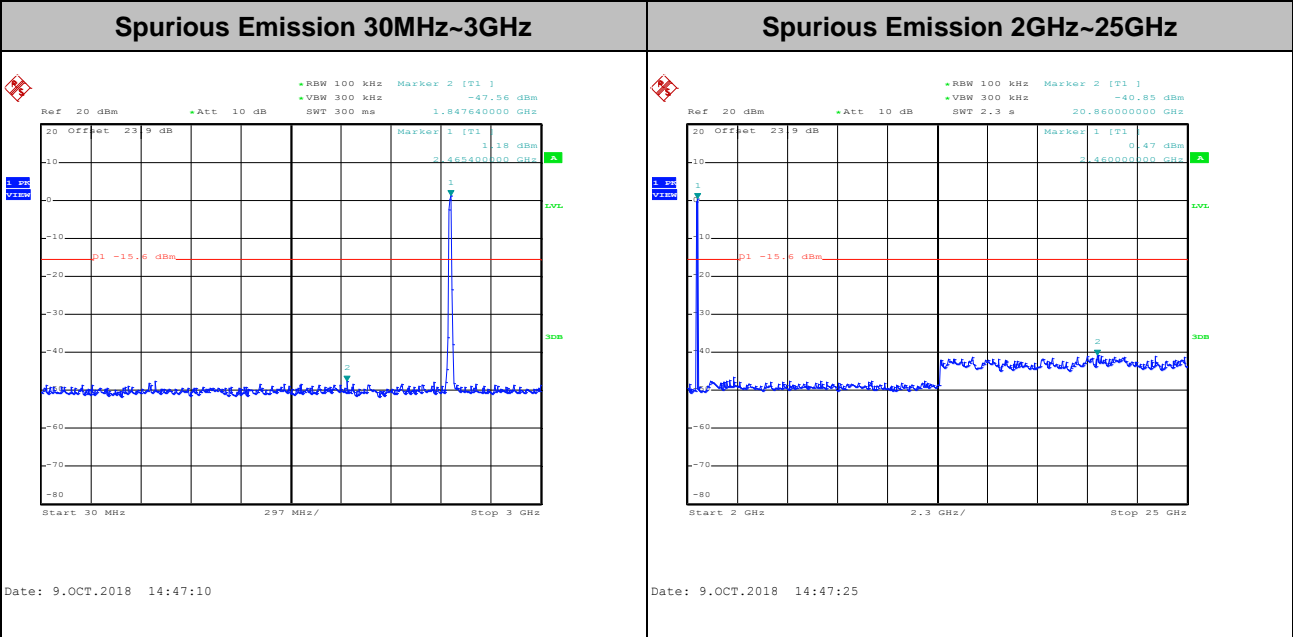
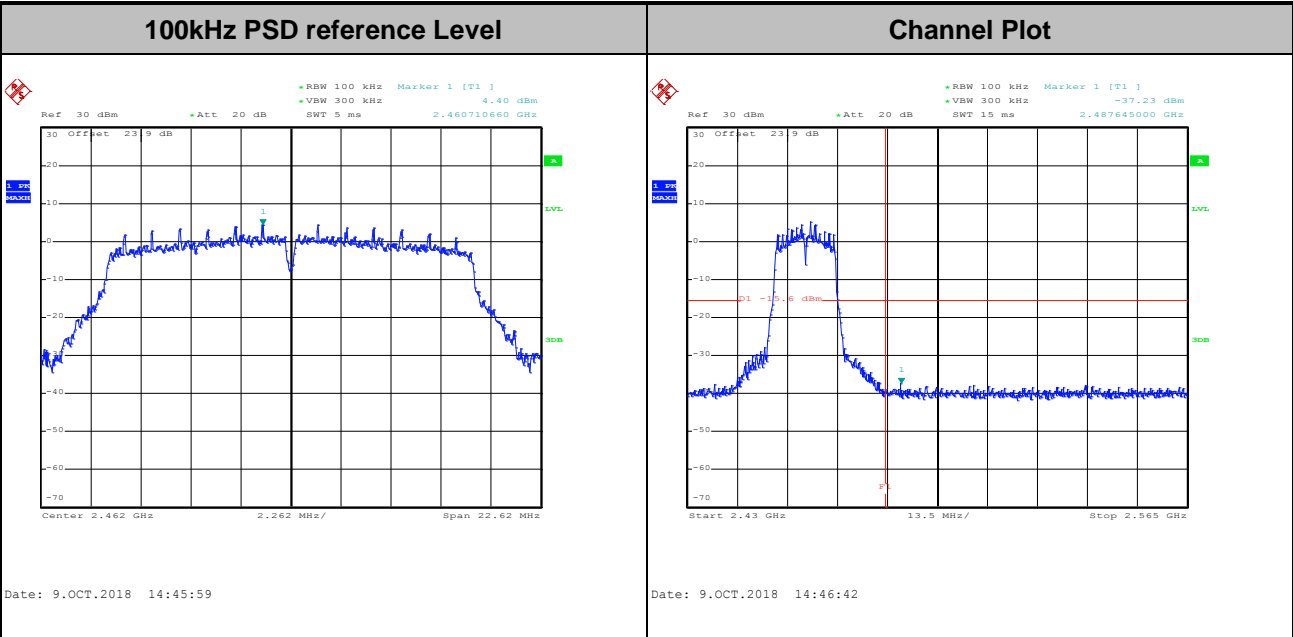



Test Mode :	802.11g	Test Channel :	12
-------------	---------	----------------	----

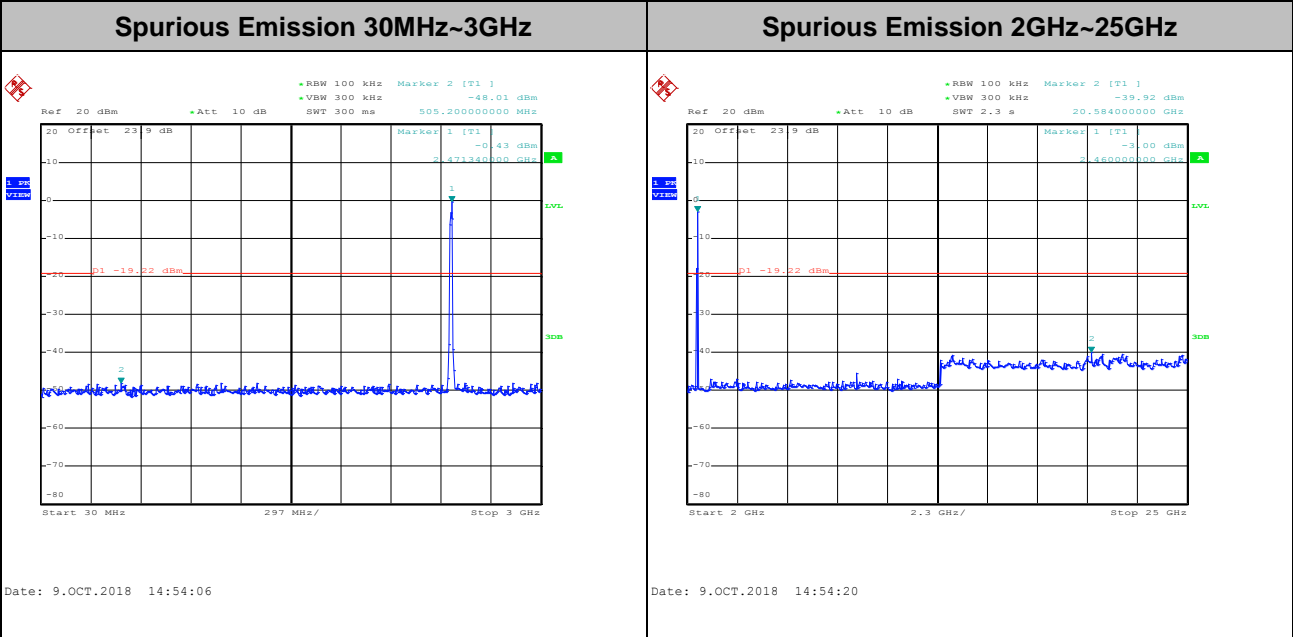
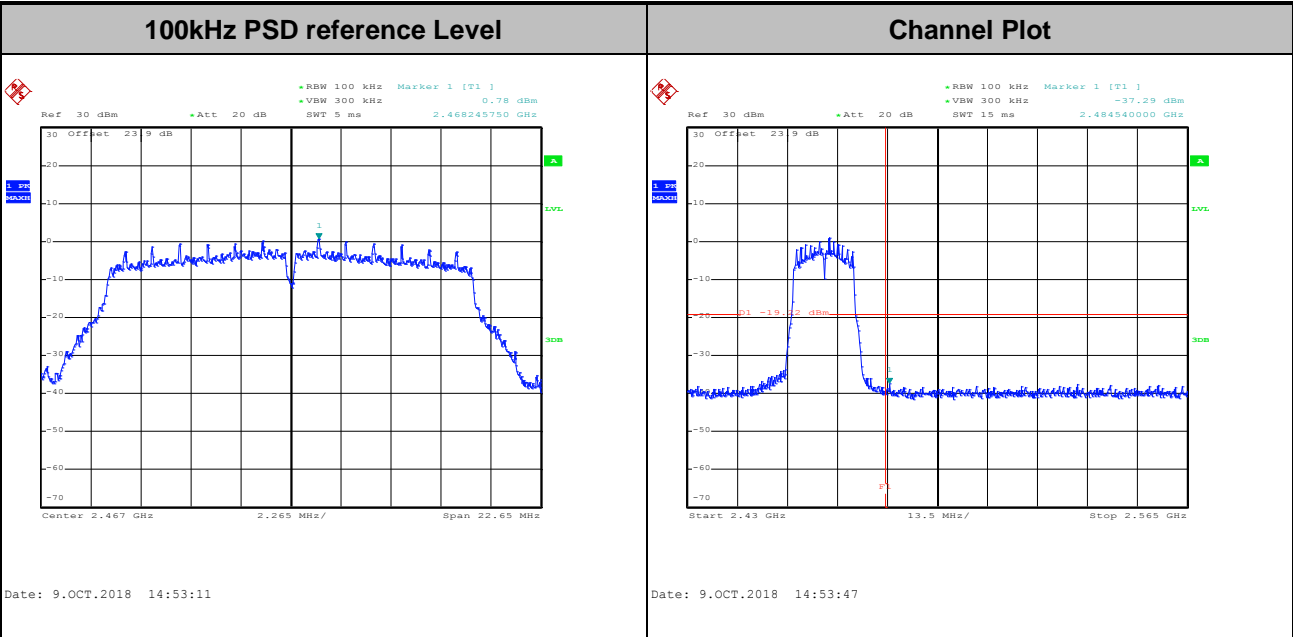



Test Mode :	802.11g	Test Channel :	13
-------------	---------	----------------	----

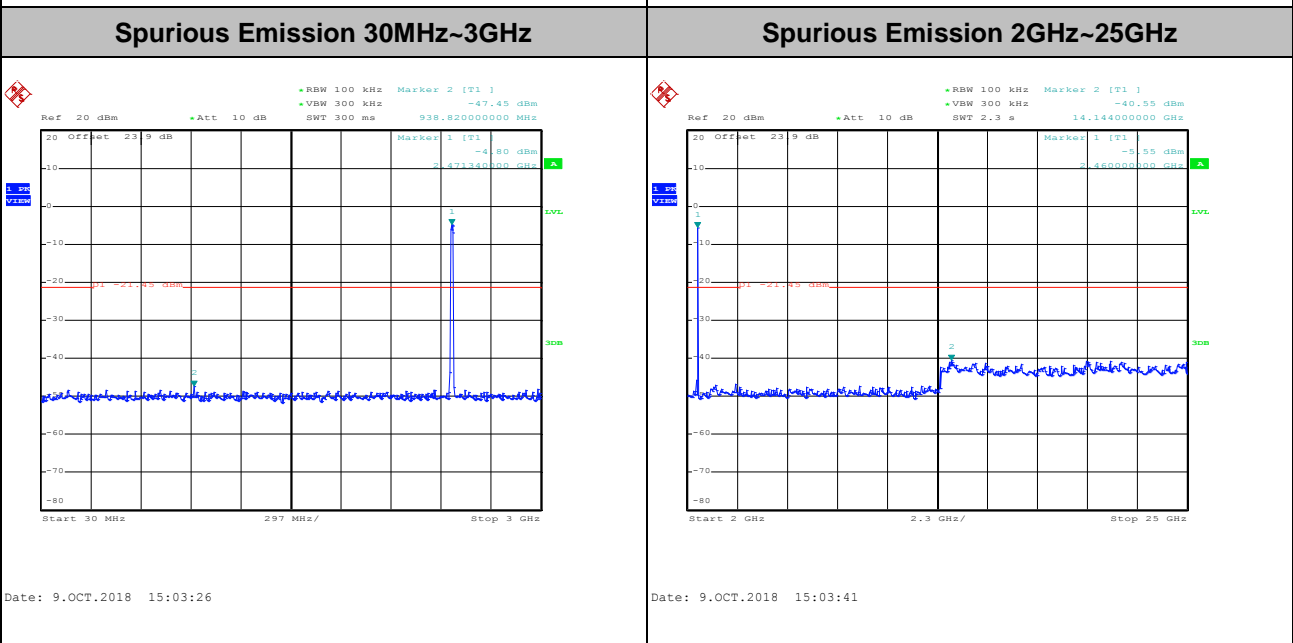
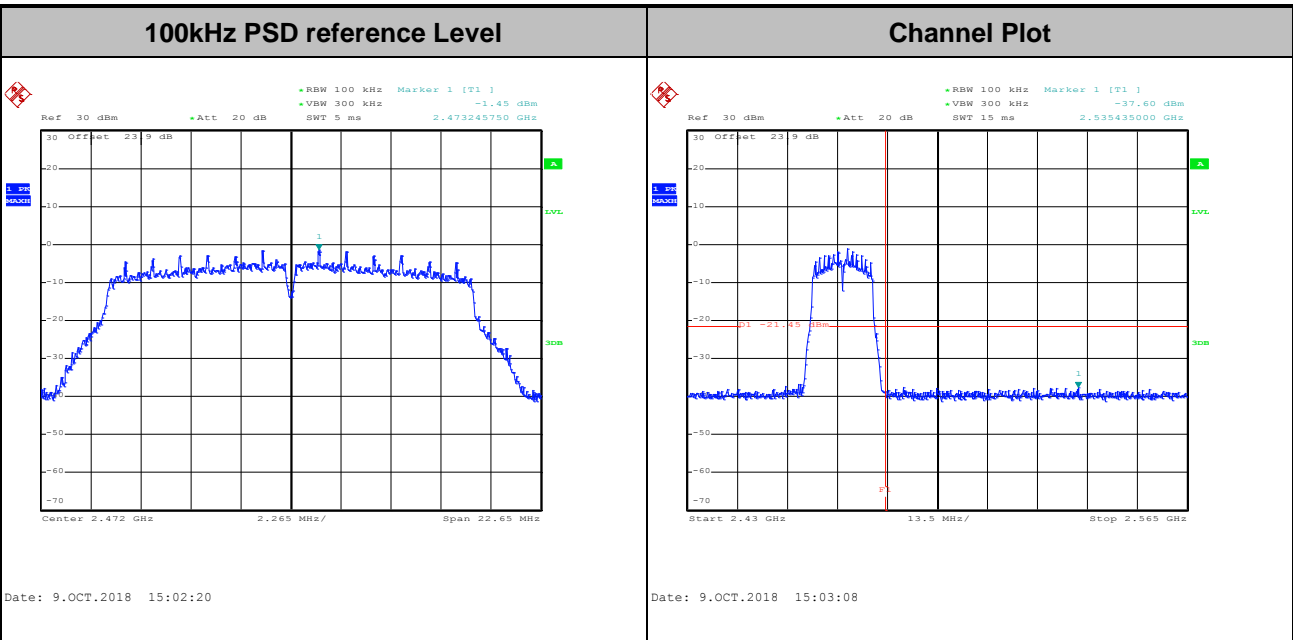



Test Mode : 802.11n HT20 Test Channel : 01

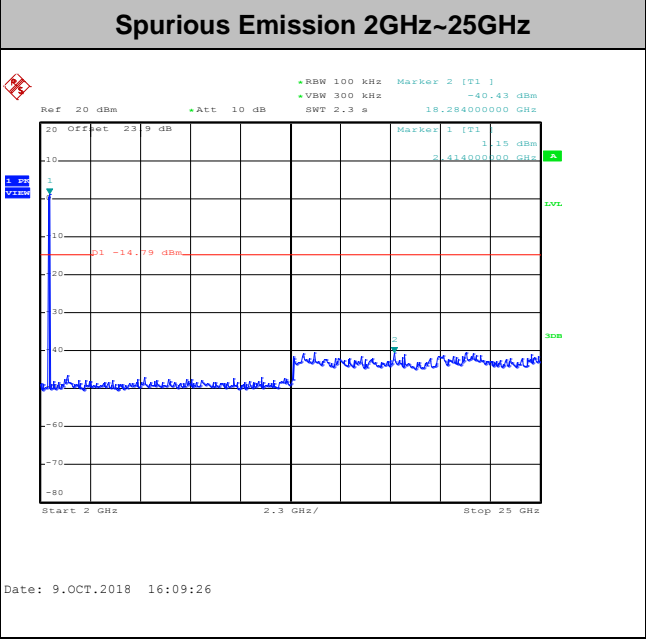
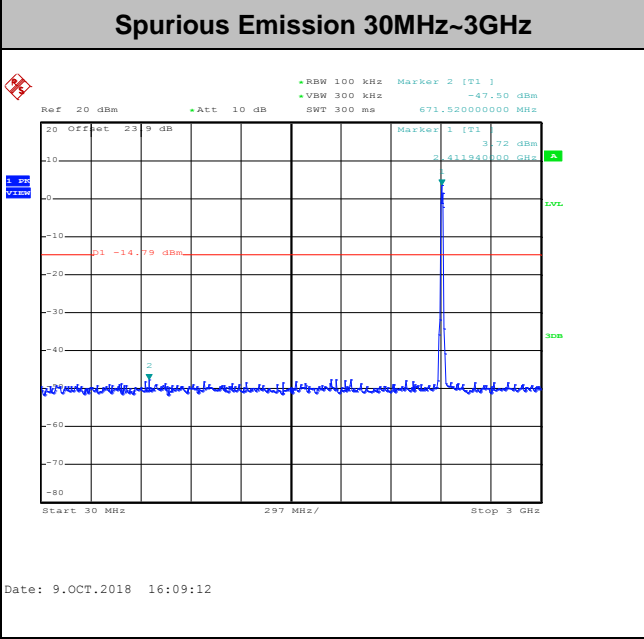
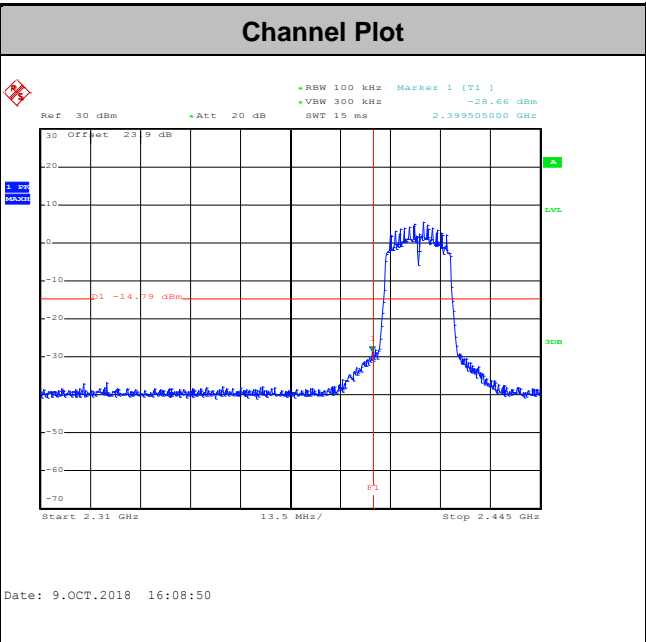
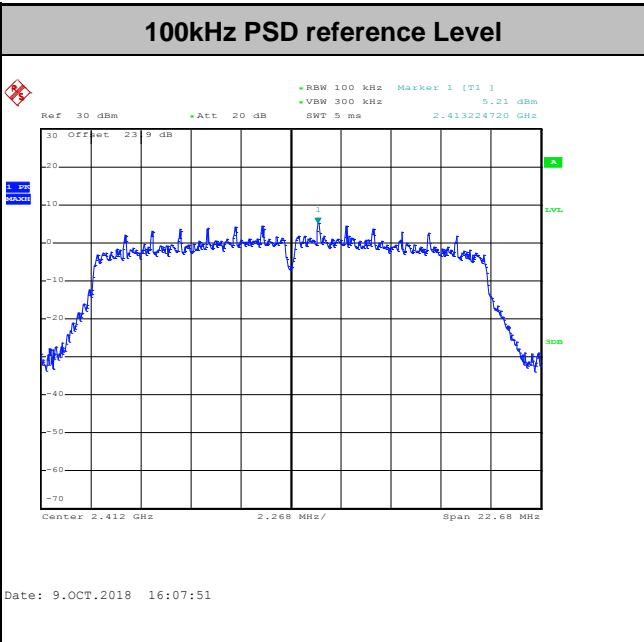



Test Mode :	802.11n HT20	Test Channel :	06
-------------	--------------	----------------	----

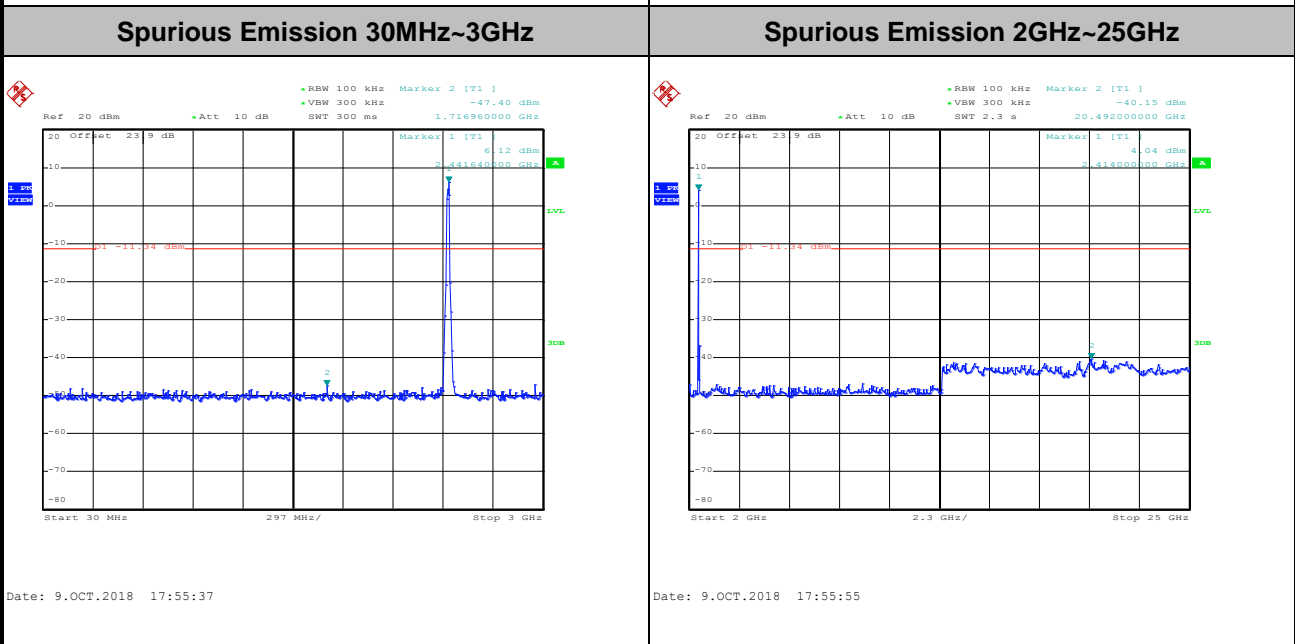
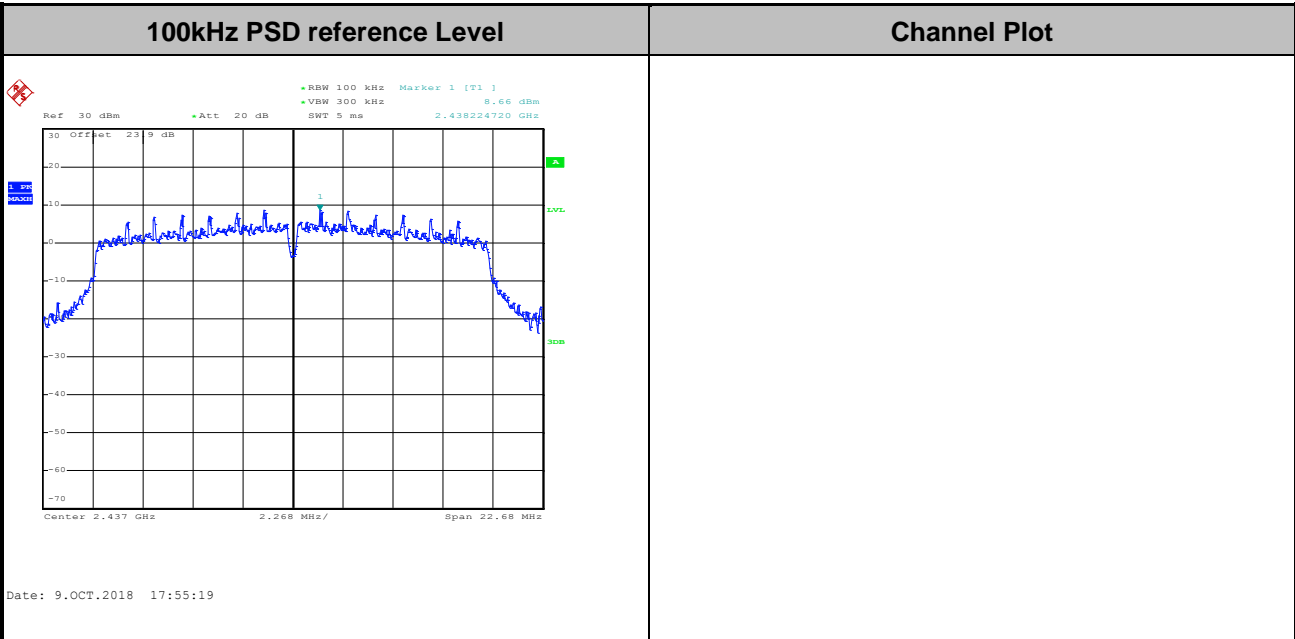



Test Mode :	802.11n HT20	Test Channel :	11
-------------	--------------	----------------	----

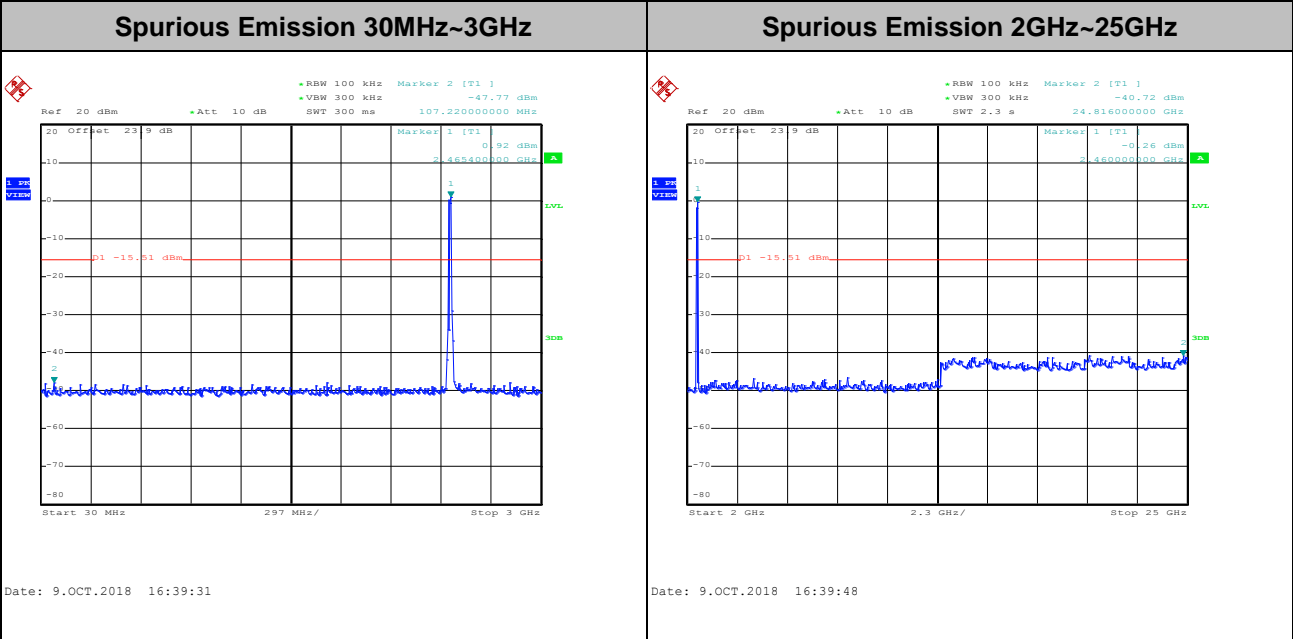
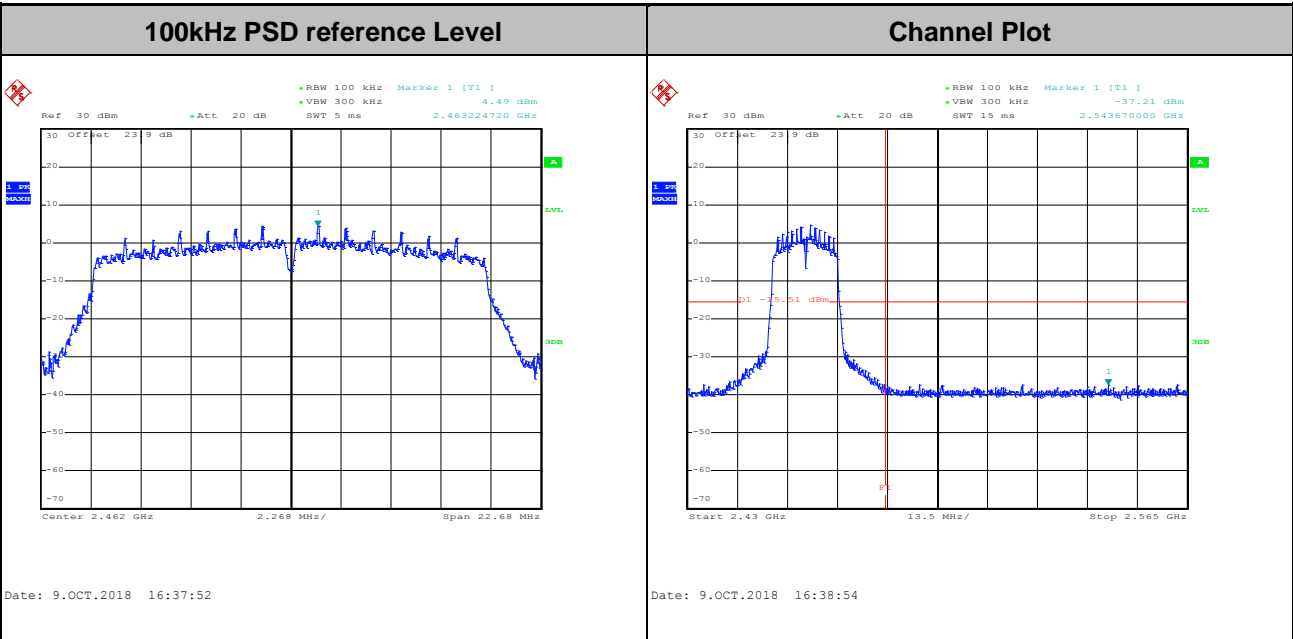



Test Mode :	802.11n HT20	Test Channel :	12
-------------	--------------	----------------	----

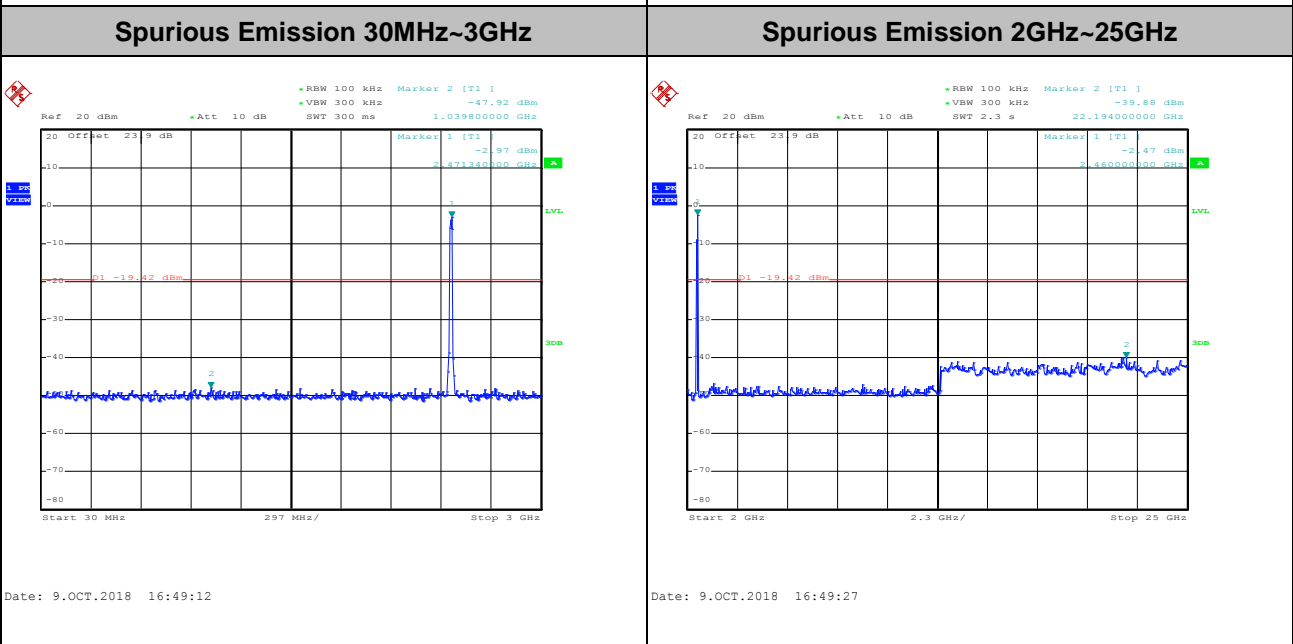
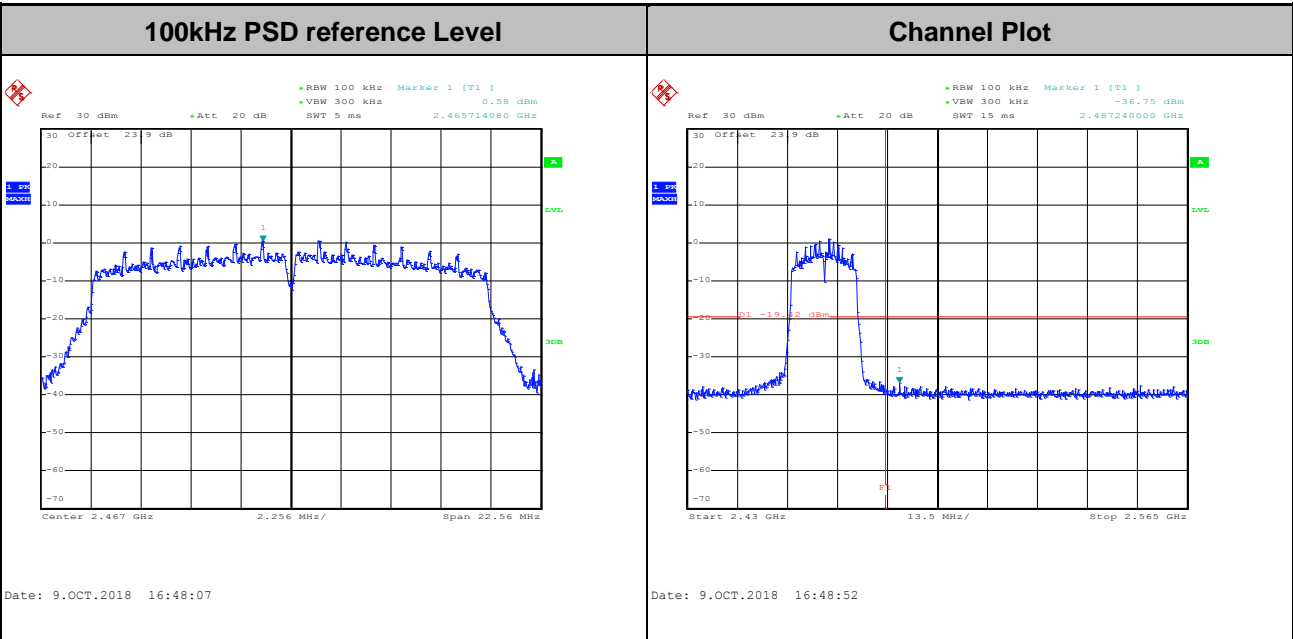



Test Mode :	802.11n HT20	Test Channel :	13
-------------	--------------	----------------	----

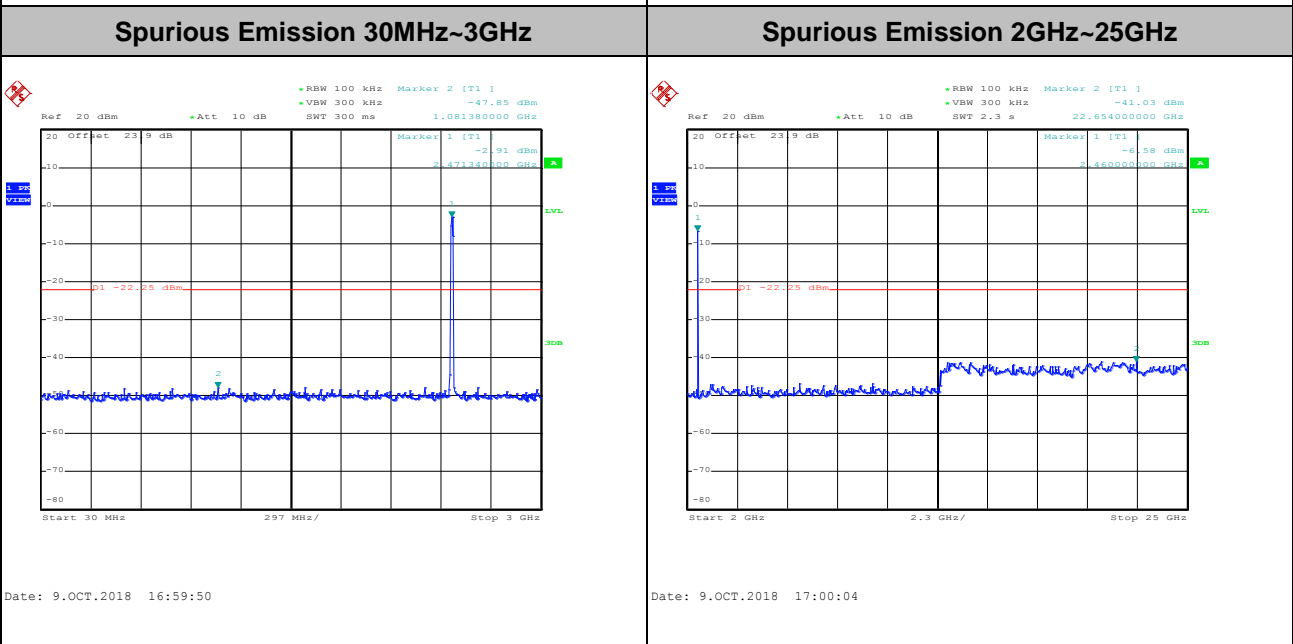
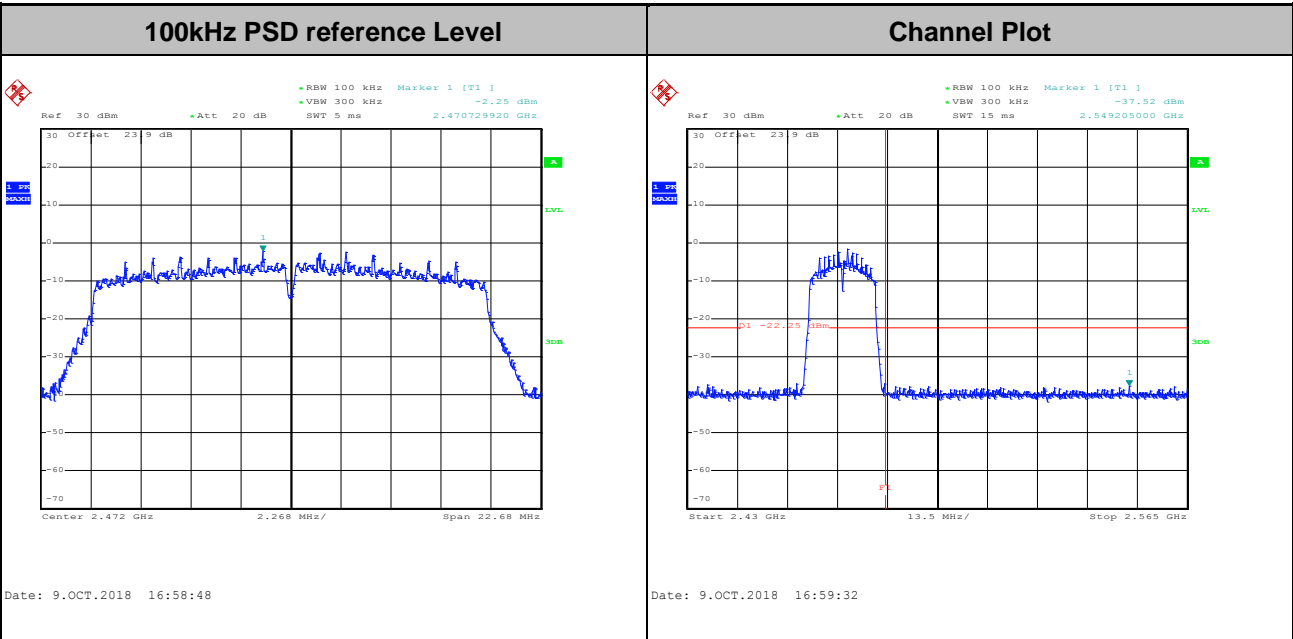



Number of TX = 2, Ant. 2 (Measured)

Test Mode :	802.11b	Test Channel :	01
-------------	---------	----------------	----

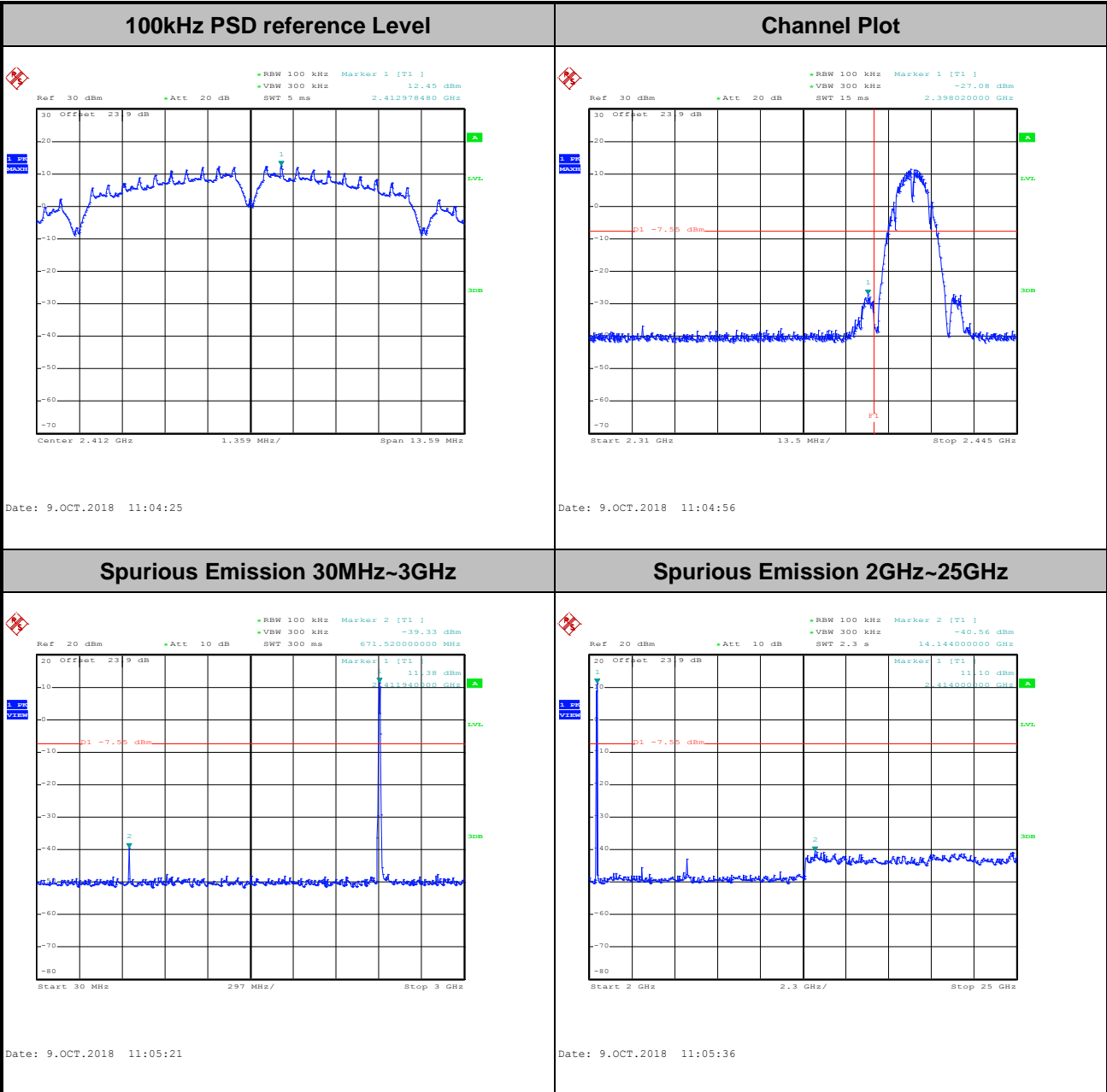



Test Mode :	802.11b	Test Channel :	06
-------------	---------	----------------	----

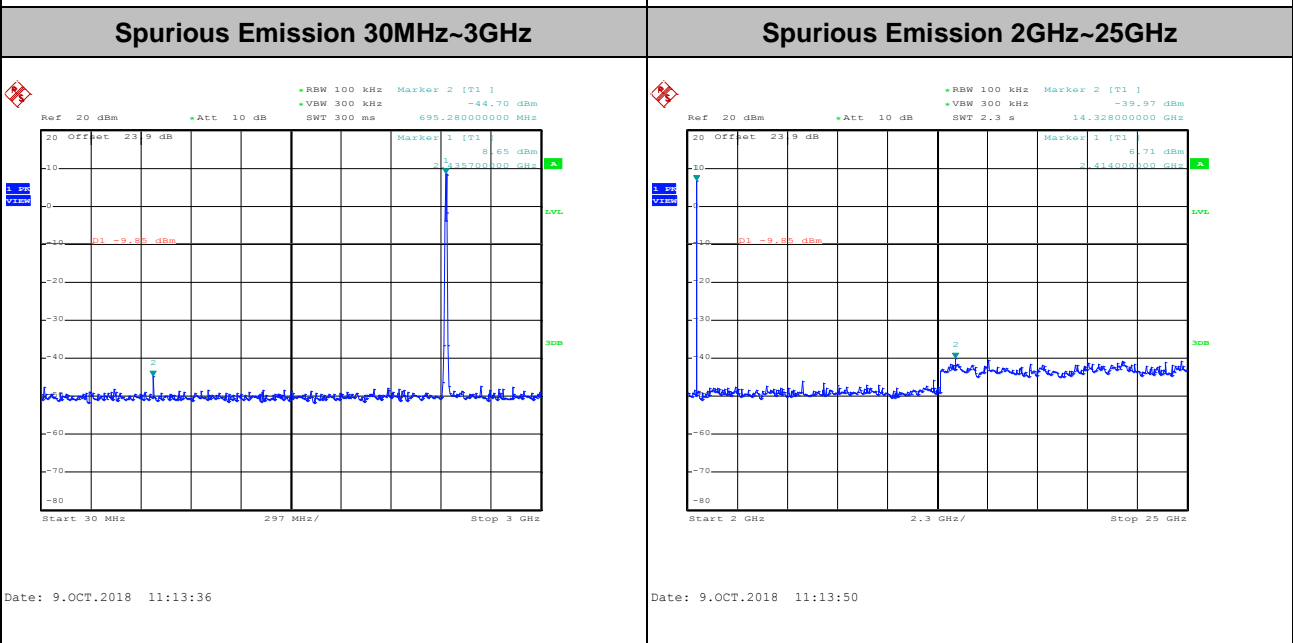
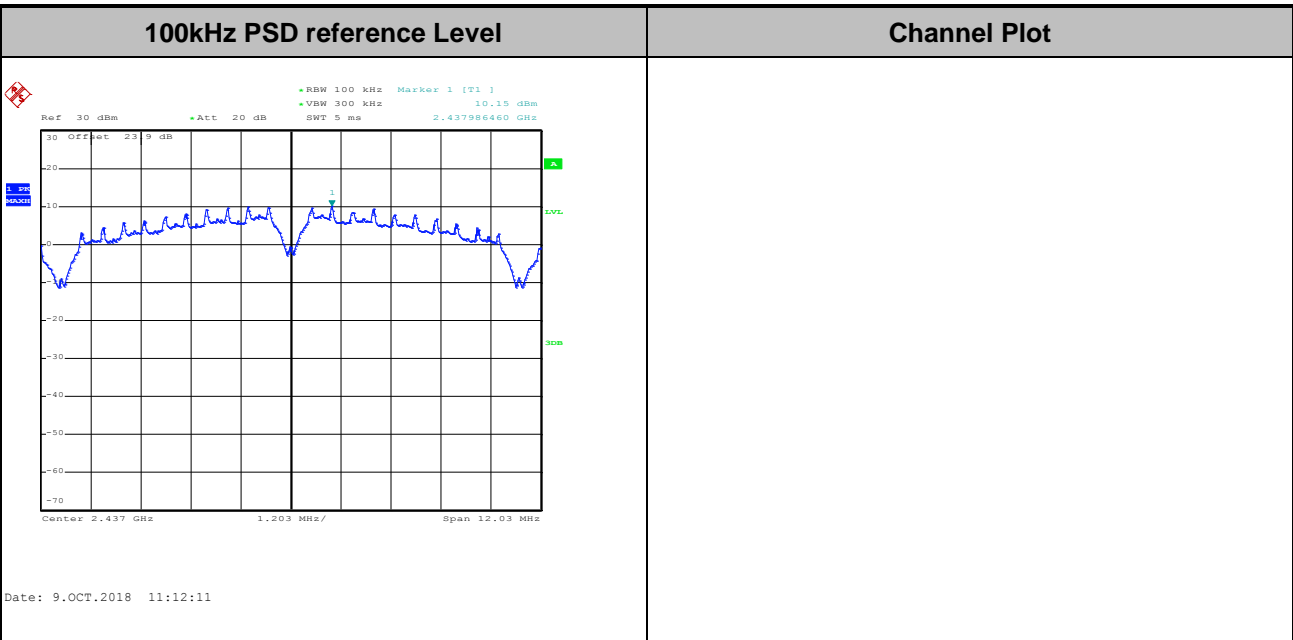



Test Mode :	802.11b	Test Channel :	11
-------------	---------	----------------	----

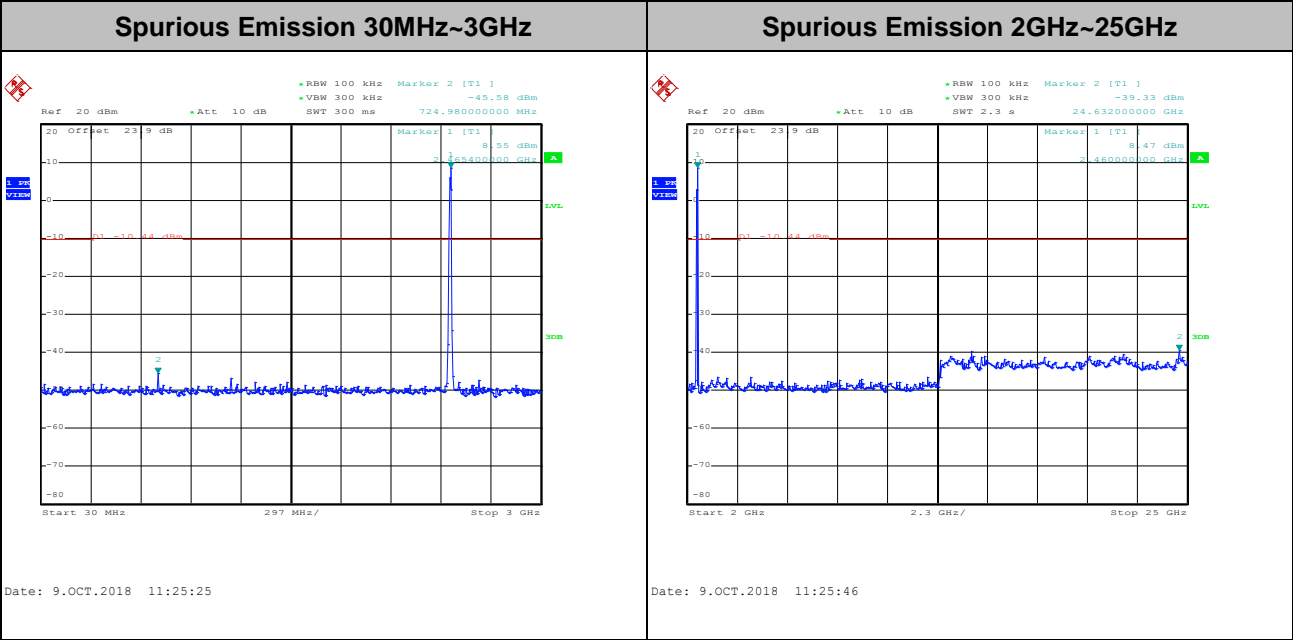
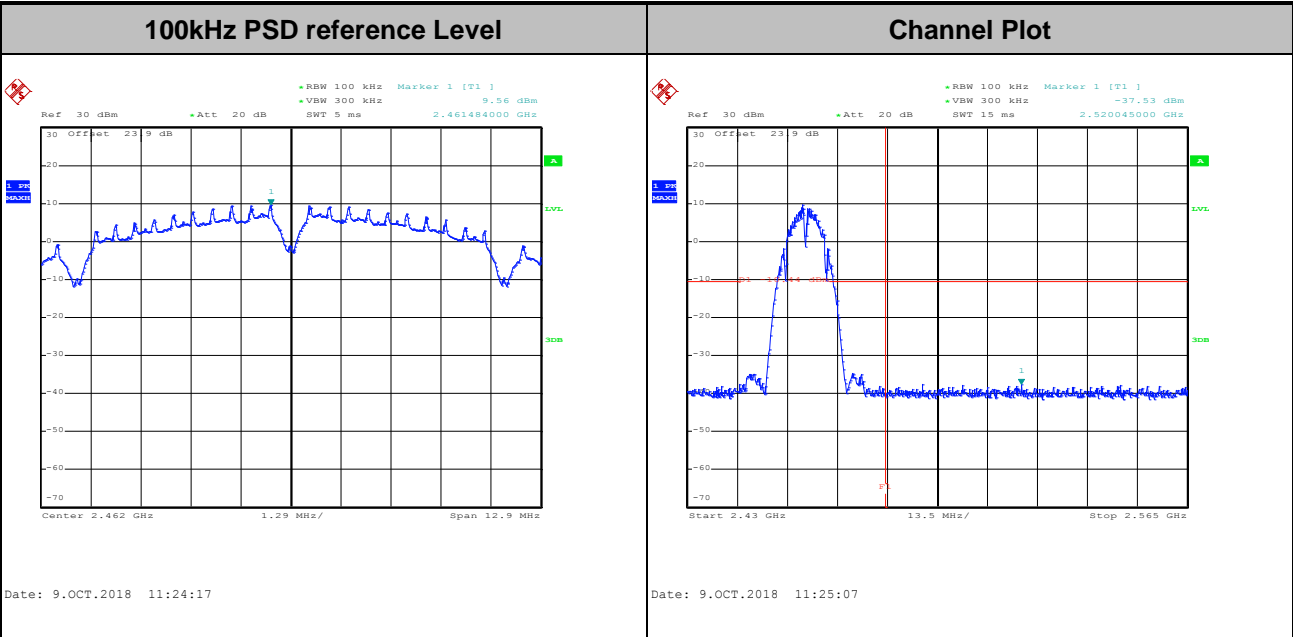



Test Mode :	802.11b	Test Channel :	12
-------------	---------	----------------	----

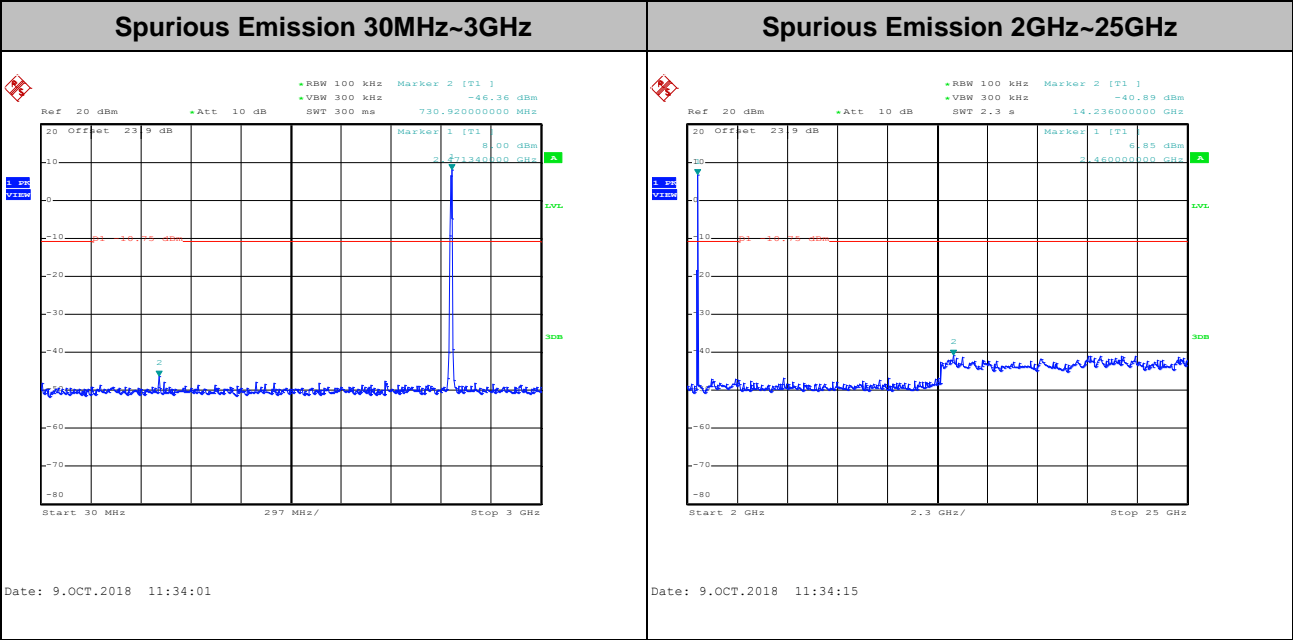
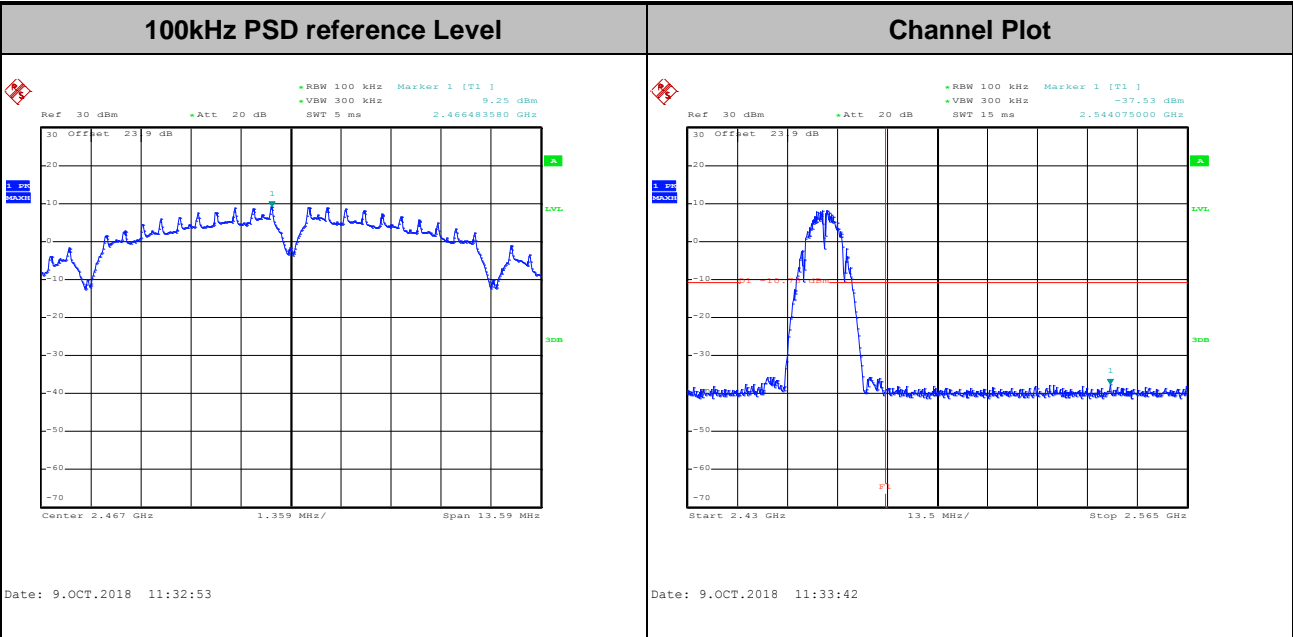



Test Mode :	802.11b	Test Channel :	13
-------------	---------	----------------	----

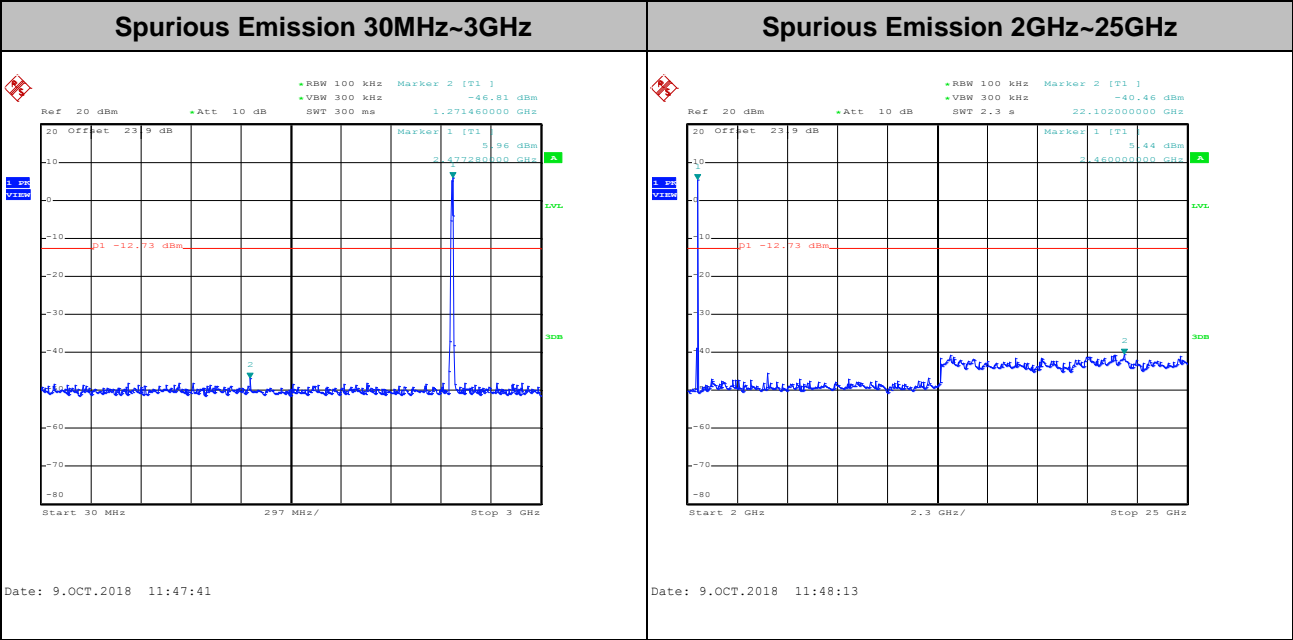
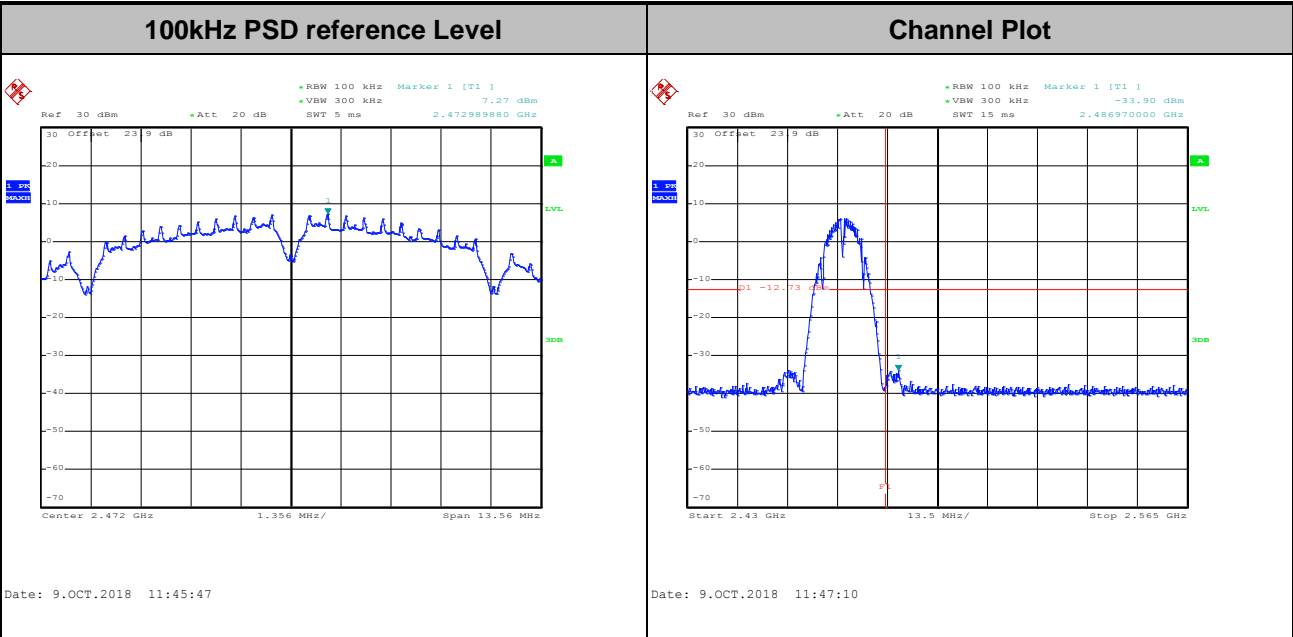



Test Mode : 802.11g Test Channel : 01

100kHz PSD reference Level

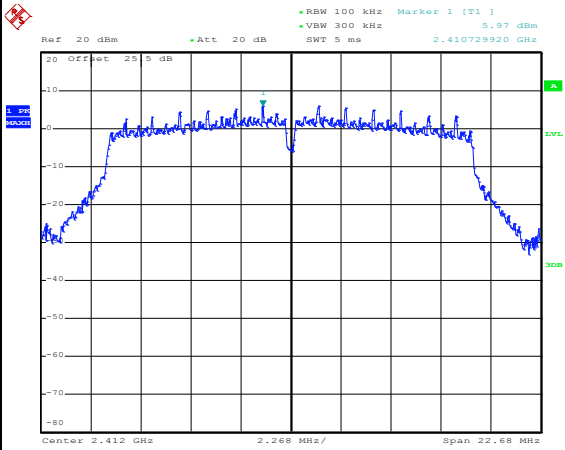

Date: 22.OCT.2018 14:47:01

Channel Plot

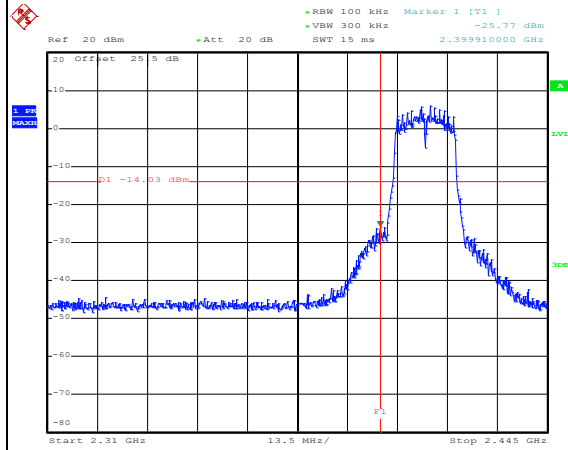

Date: 22.OCT.2018 14:47:35

Spurious Emission 30MHz~3GHz

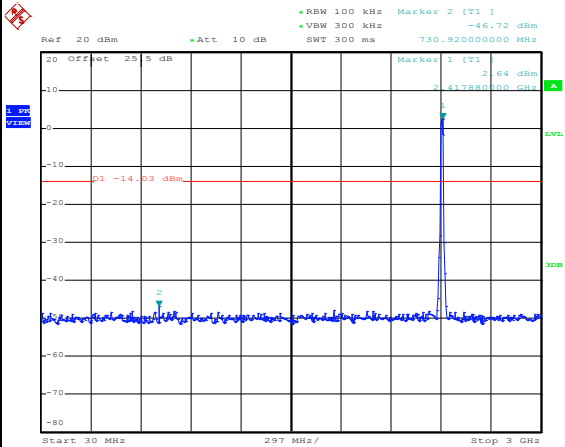

Date: 22.OCT.2018 14:48:25

Spurious Emission 2GHz~25GHz

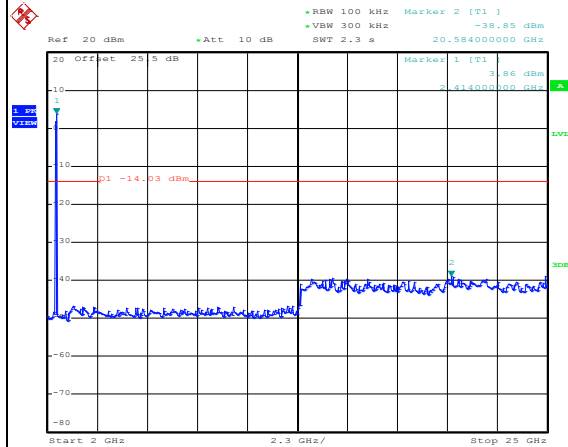

Date: 22.OCT.2018 14:48:39



Test Mode :	802.11g	Test Channel :	06
-------------	---------	----------------	----

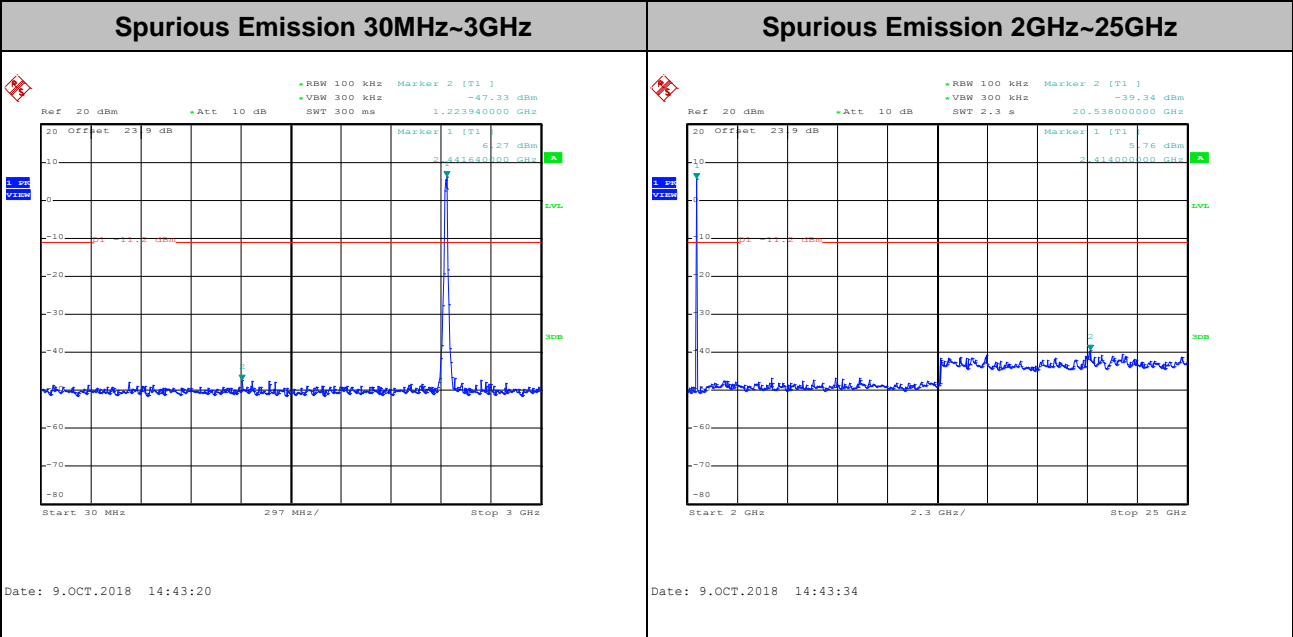
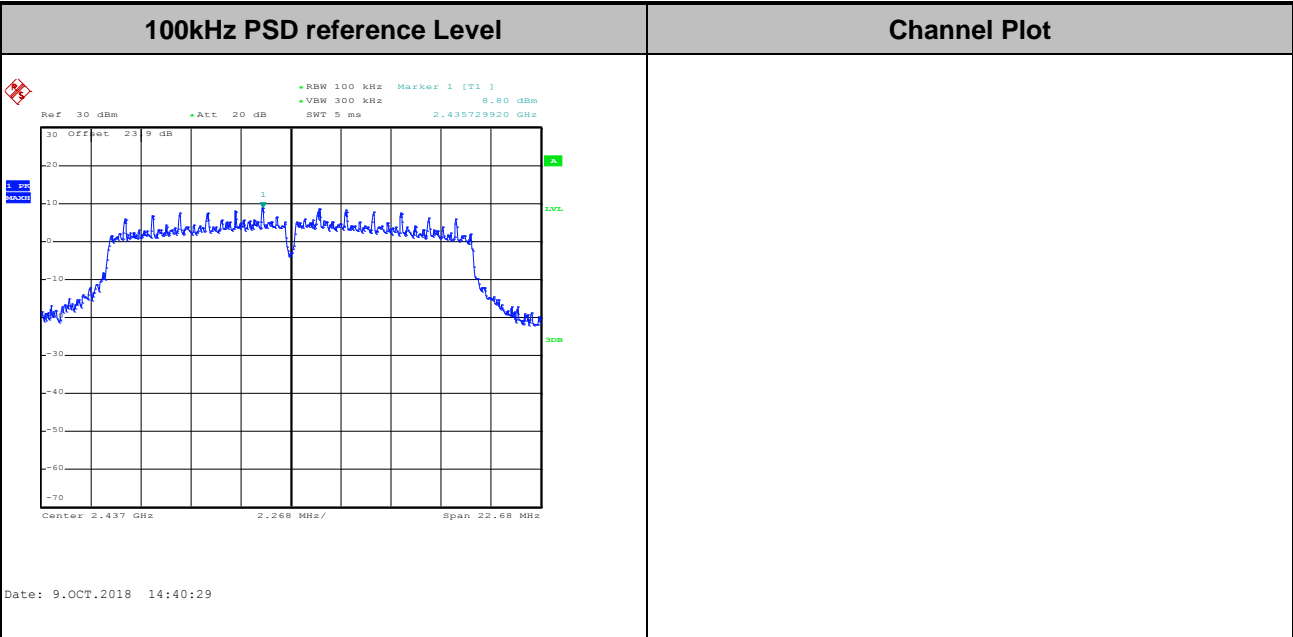



Test Mode :	802.11g	Test Channel :	11
-------------	---------	----------------	----

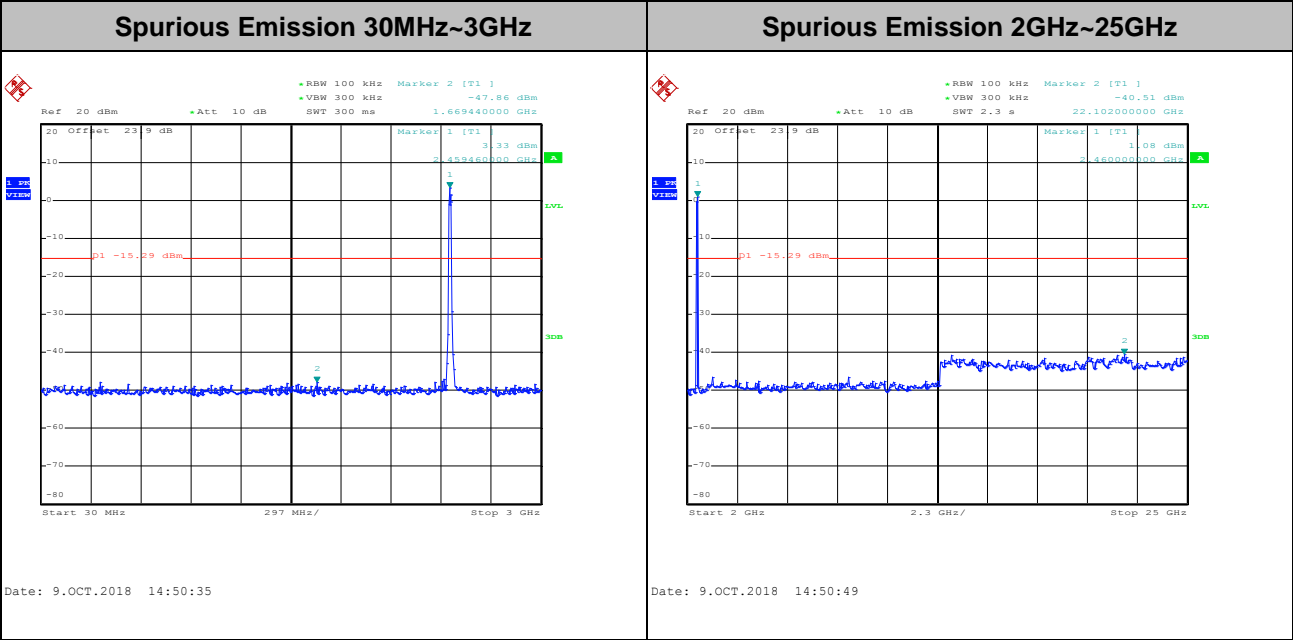
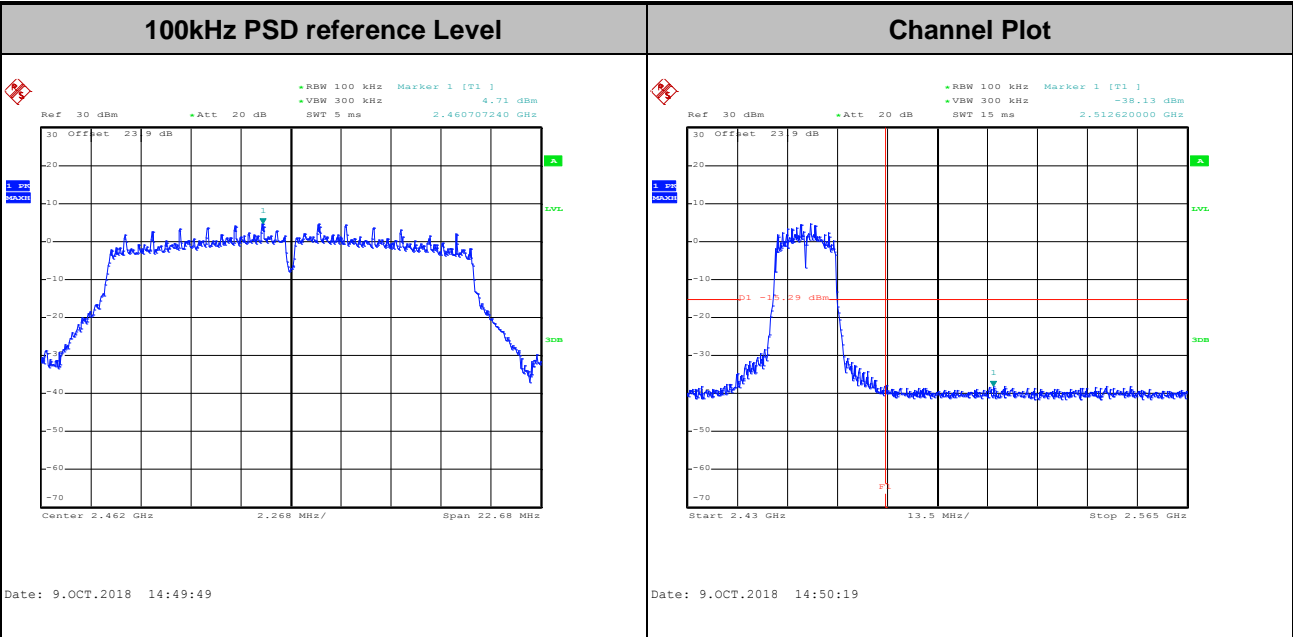



Test Mode :	802.11g	Test Channel :	12
-------------	---------	----------------	----

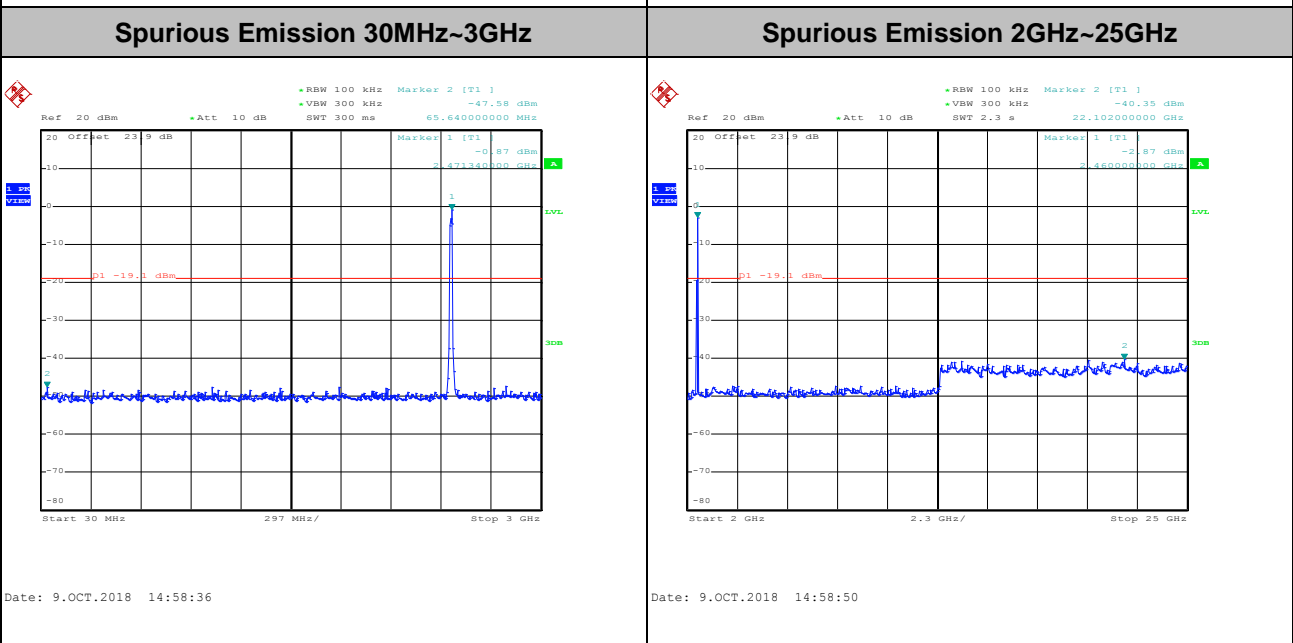
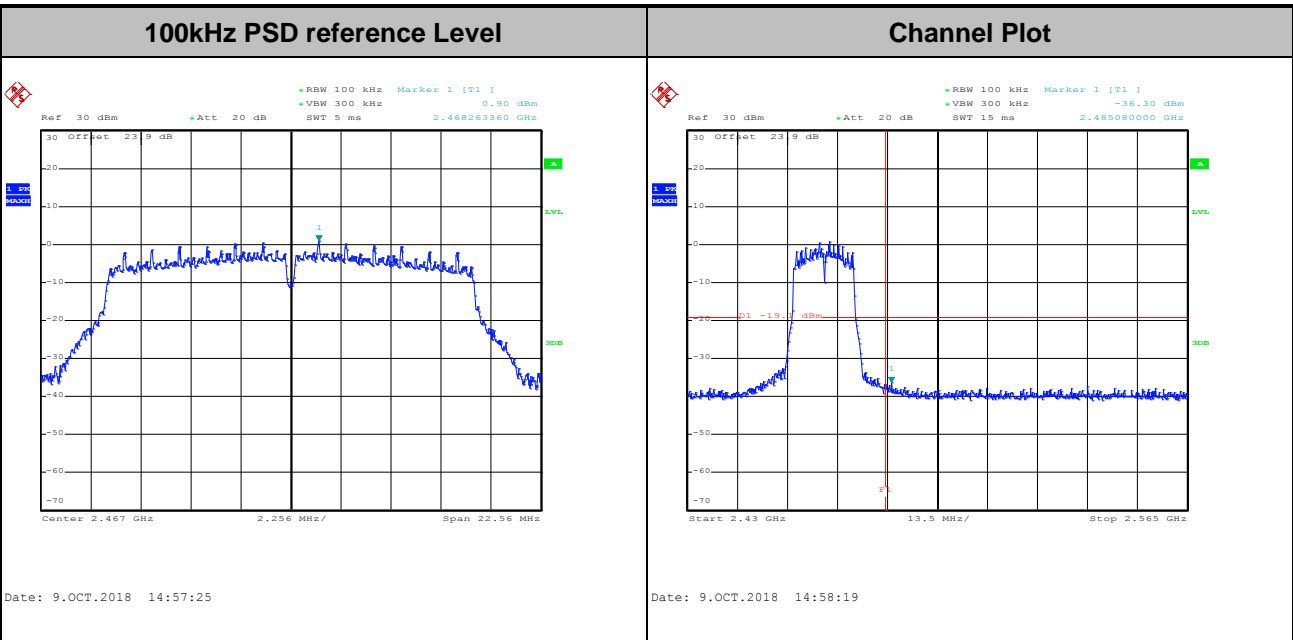



Test Mode :	802.11g	Test Channel :	13
-------------	---------	----------------	----

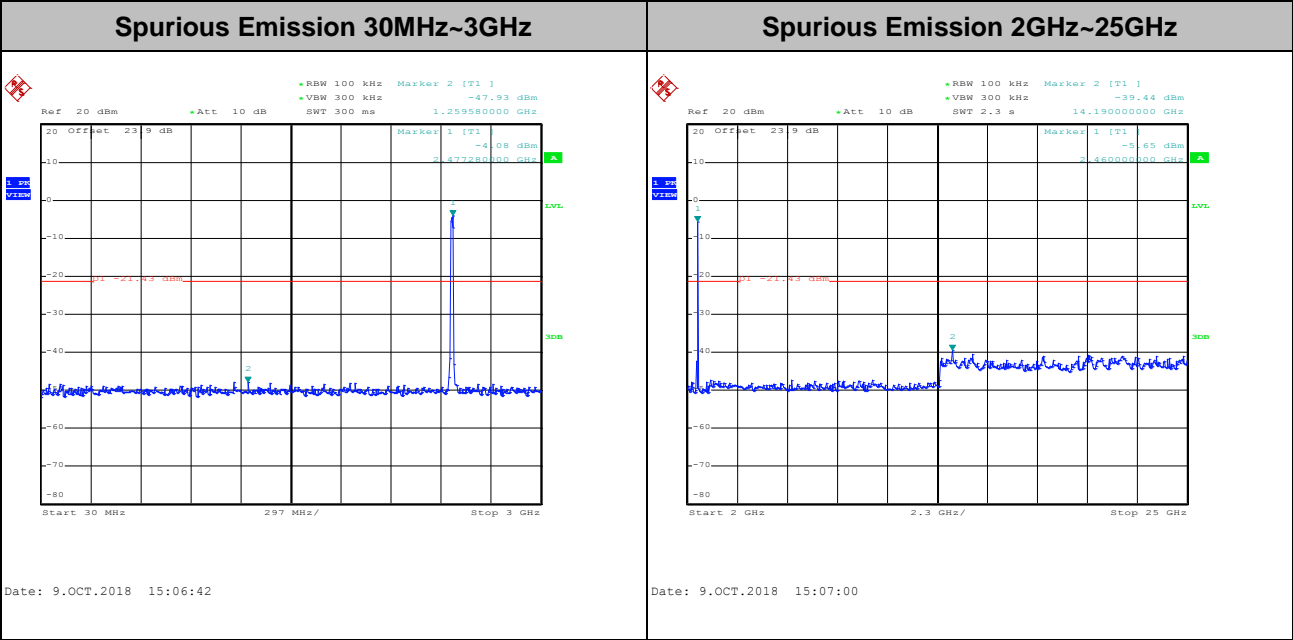
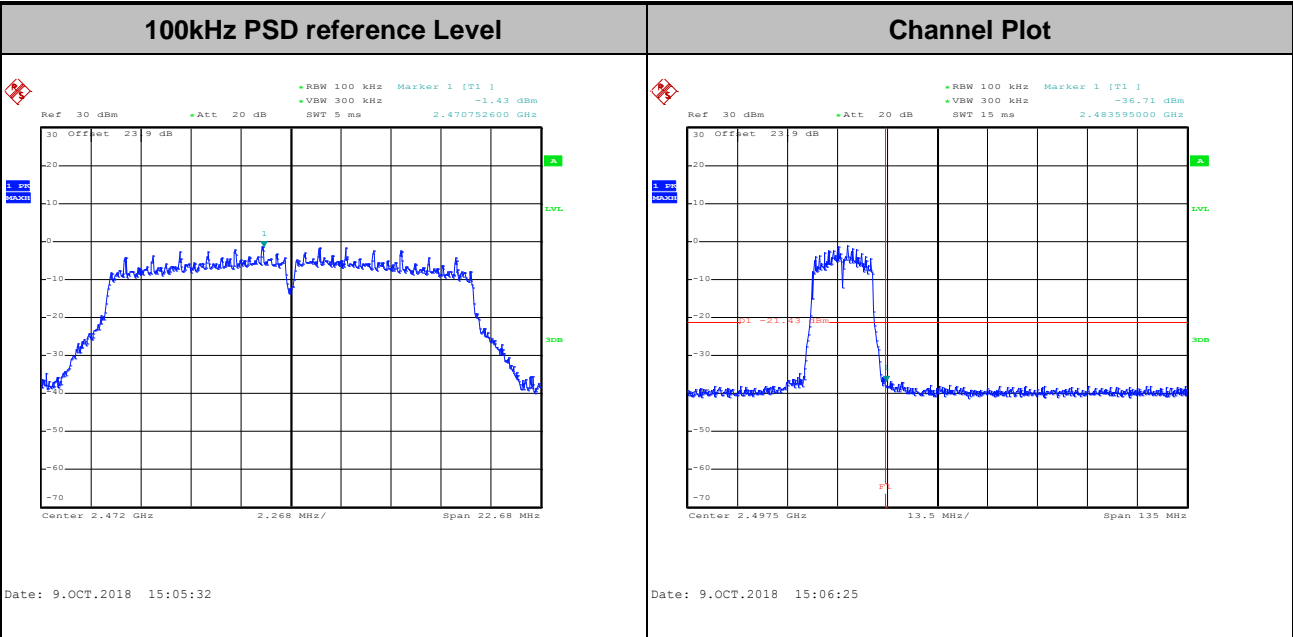



Test Mode :	802.11n HT20	Test Channel :	01
-------------	--------------	----------------	----

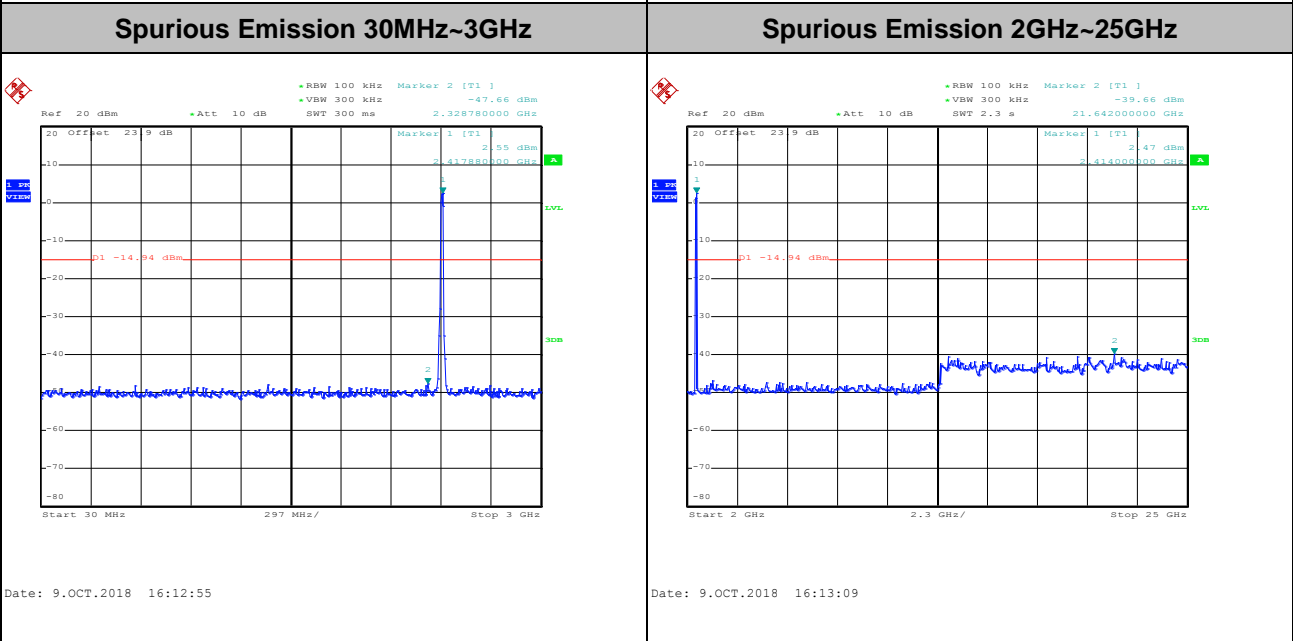
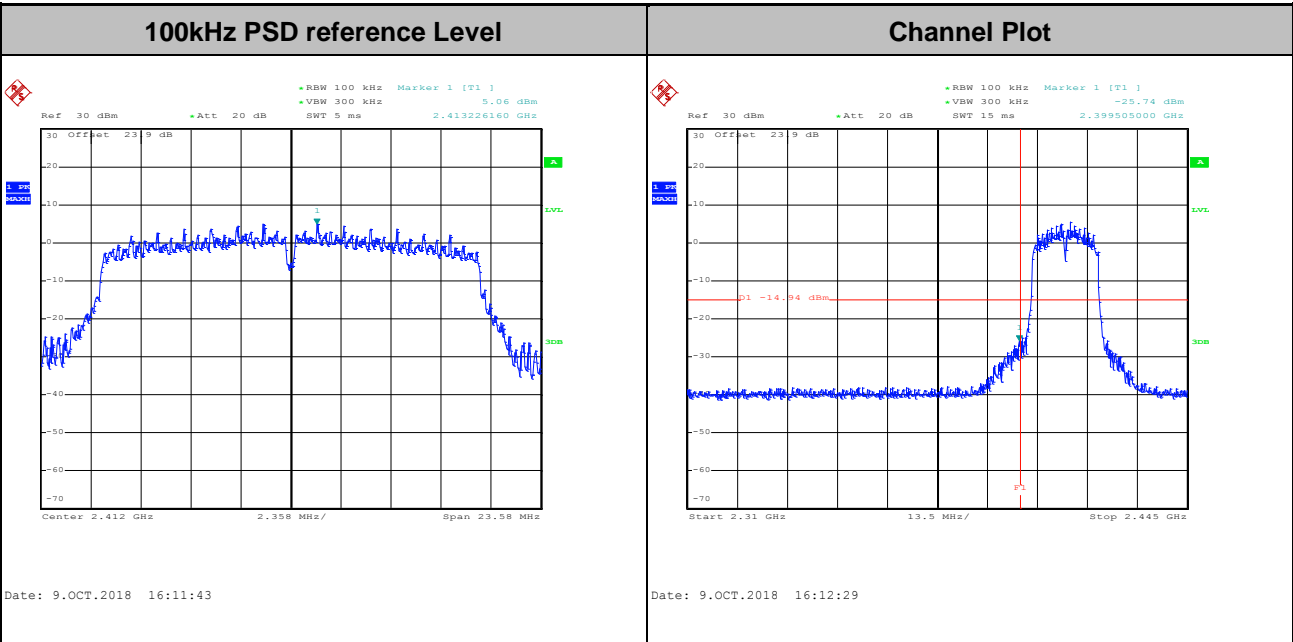



Test Mode :	802.11n HT20	Test Channel :	06
-------------	--------------	----------------	----

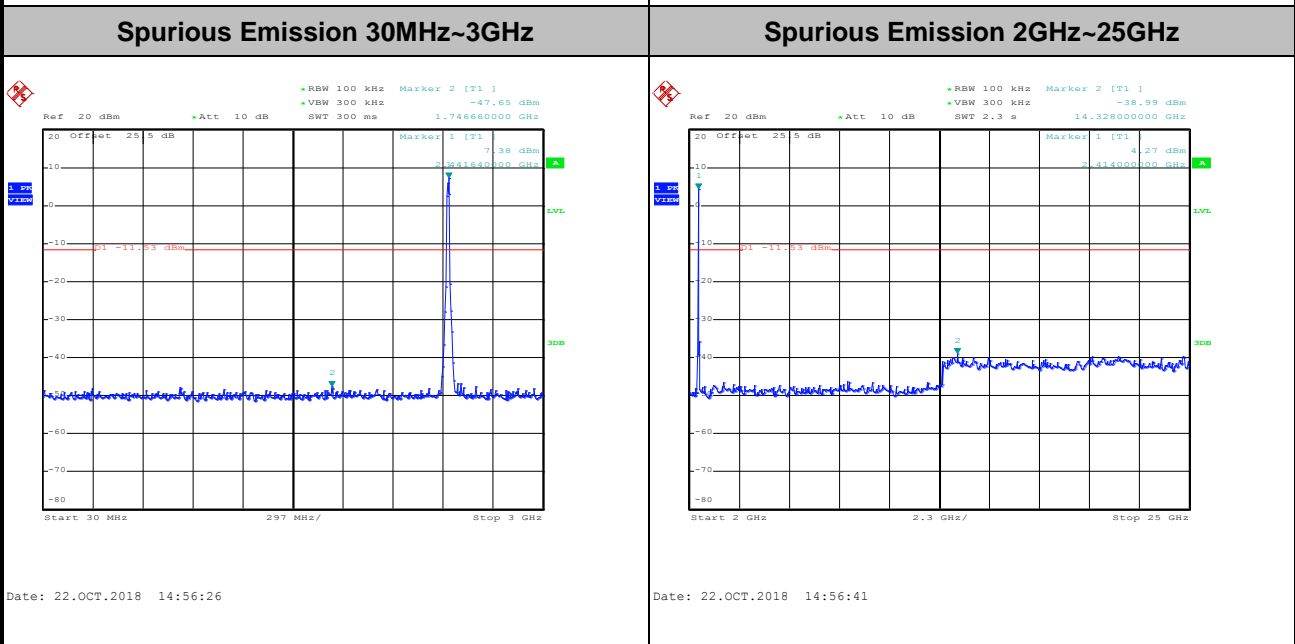
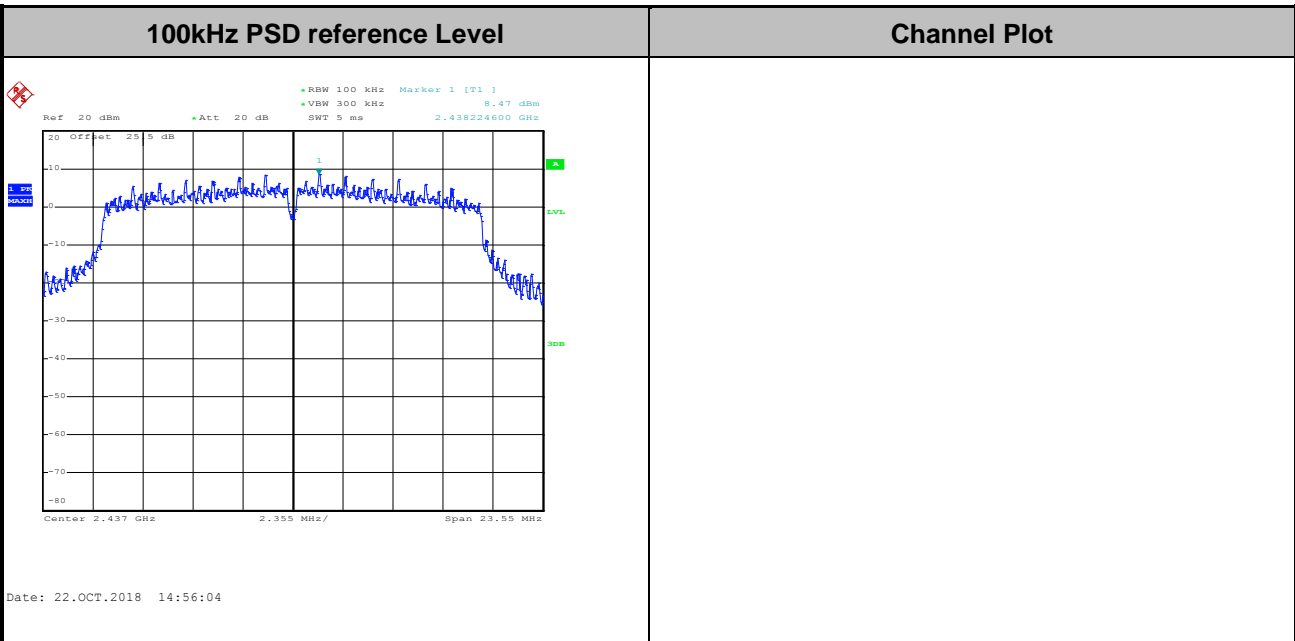



Test Mode :	802.11n HT20	Test Channel :	11
-------------	--------------	----------------	----

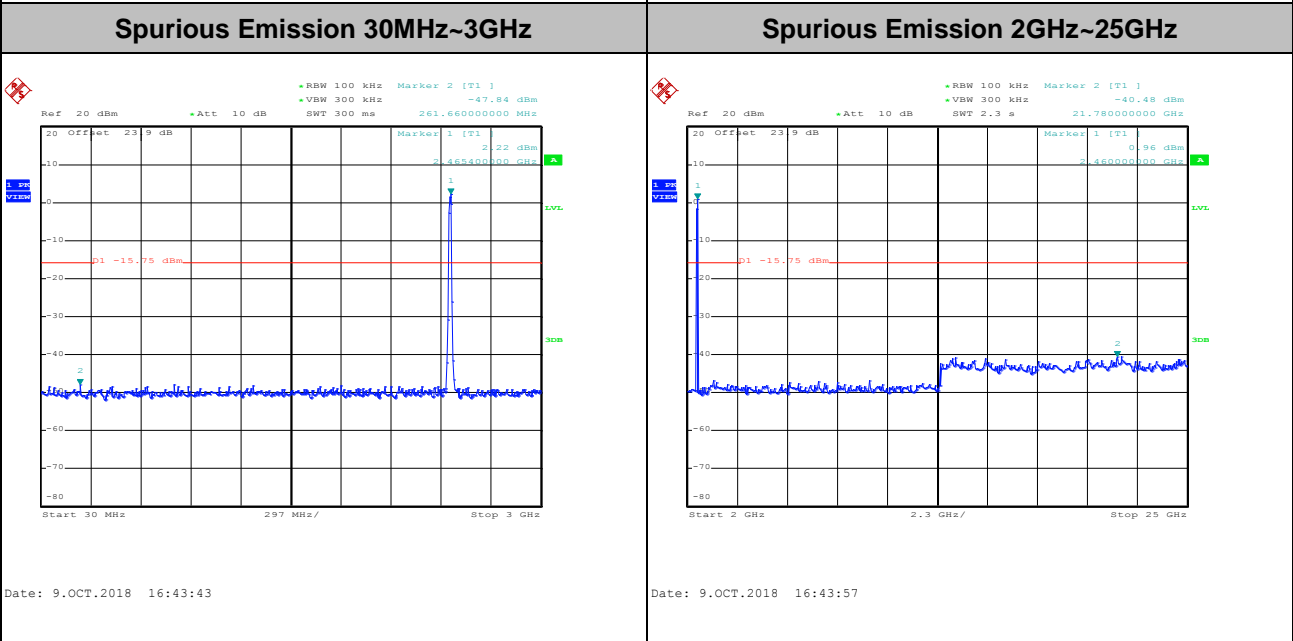
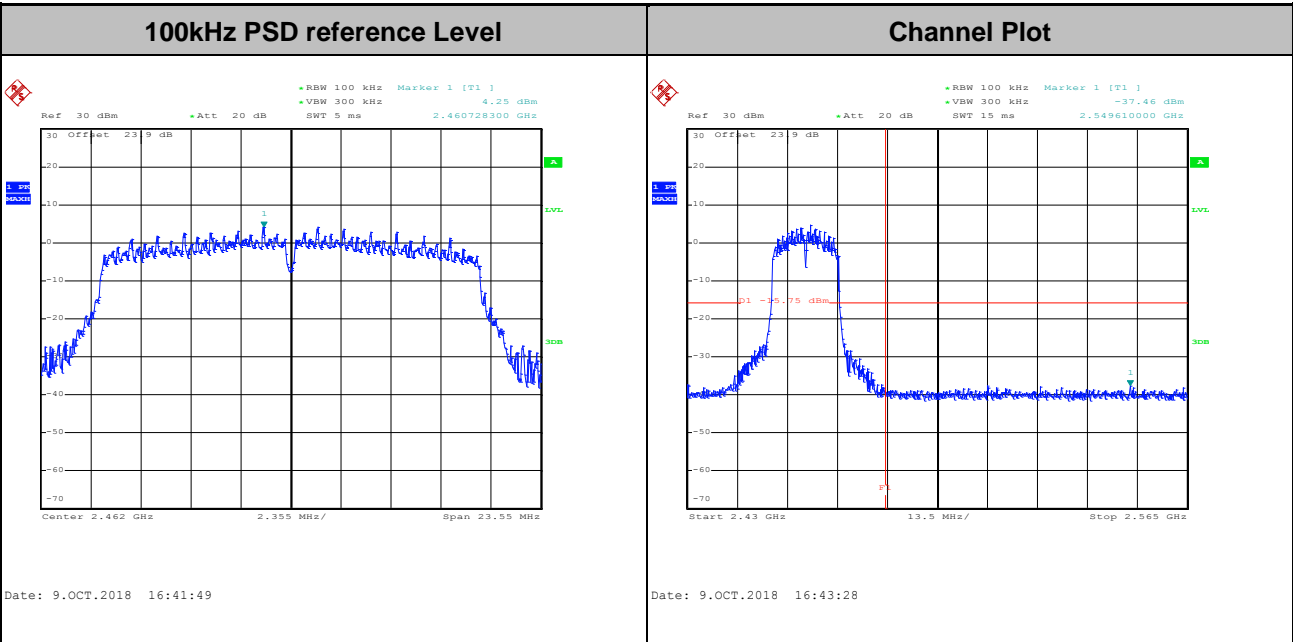



Test Mode : 802.11n HT20 Test Channel : 12

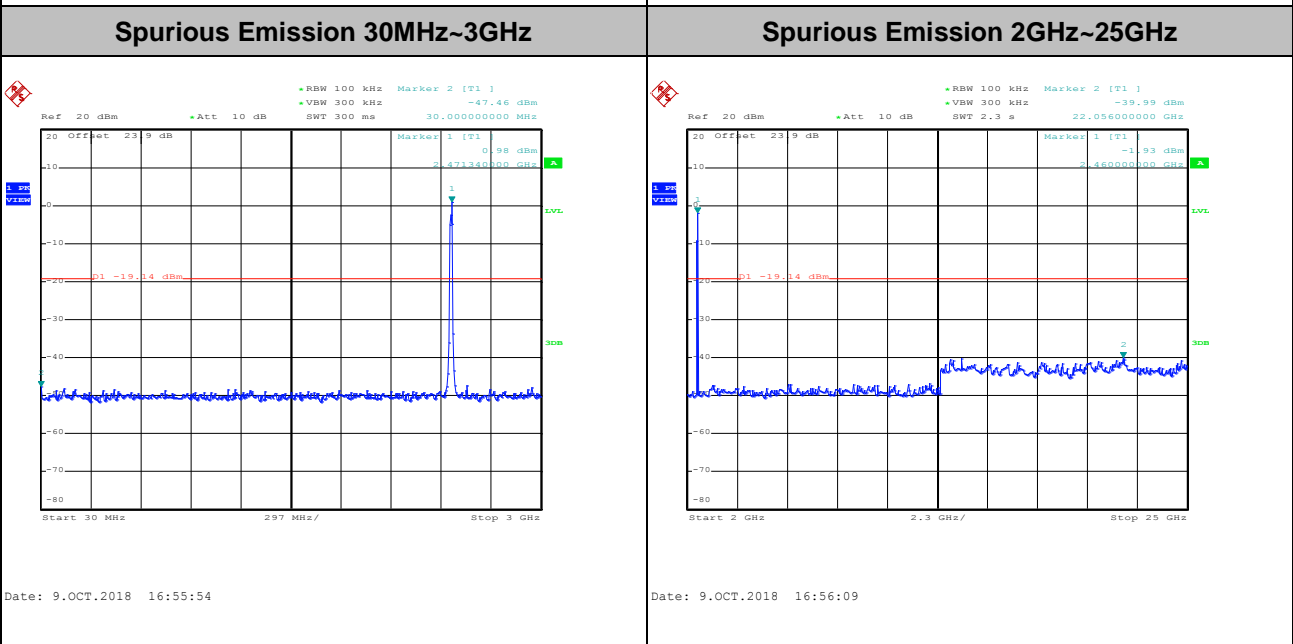
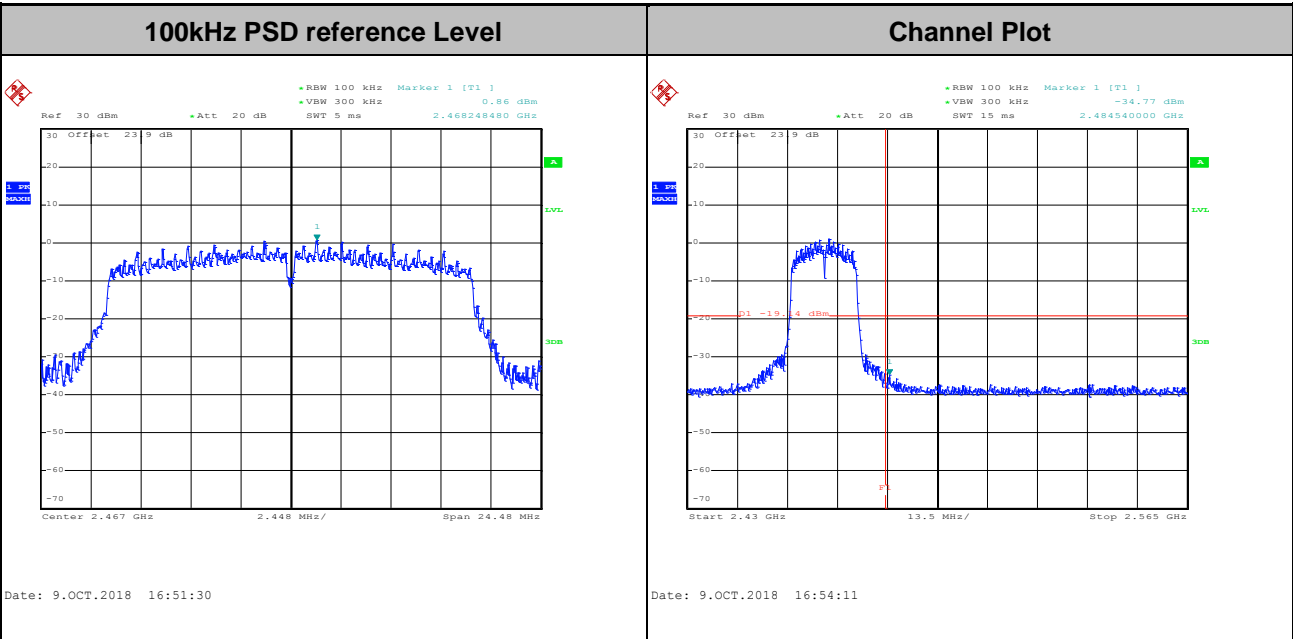



Test Mode :	802.11n HT20	Test Channel :	13
-------------	--------------	----------------	----

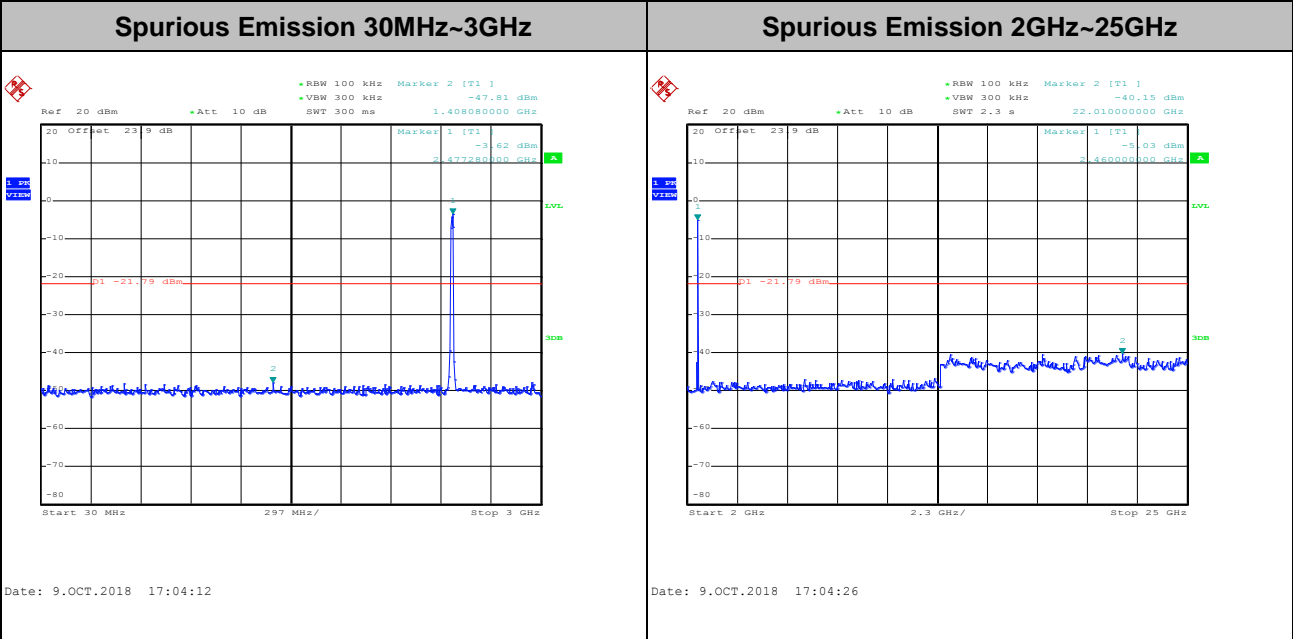
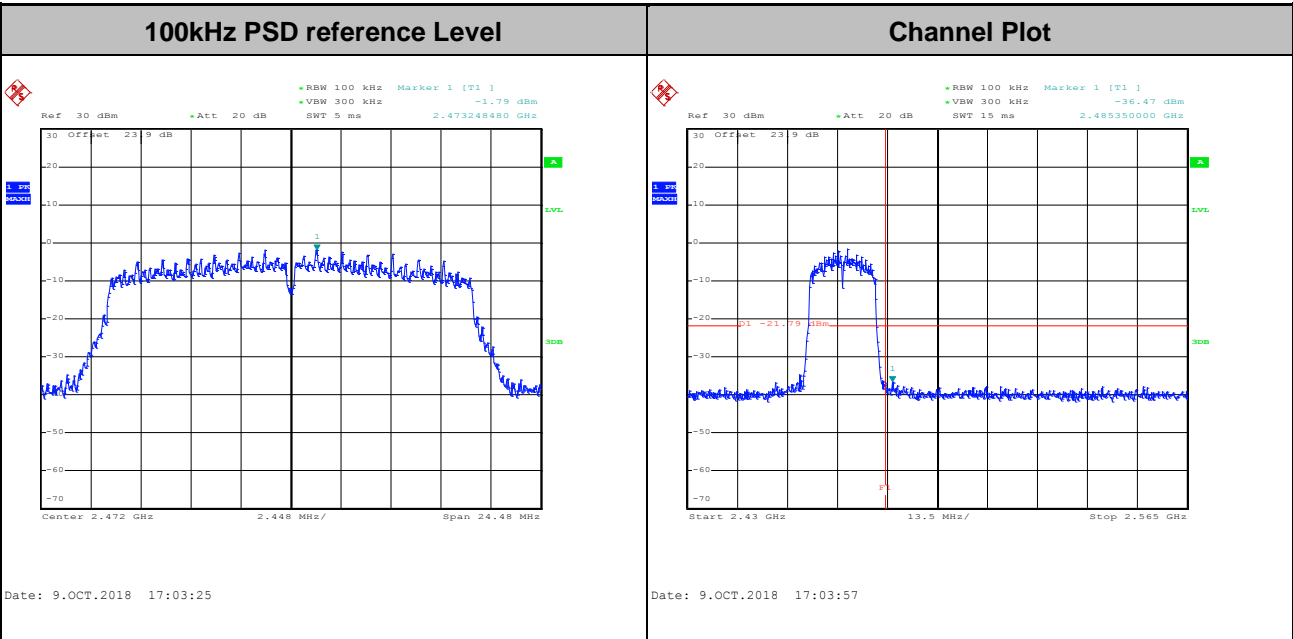



3.5 Radiated Band Edges and Spurious Emission Measurement

3.5.1 Limit of Radiated band edge and Spurious Emission Measurement

In any 100 kHz bandwidth outside the intentional radiator frequency band, all harmonics/spurious must be at least 20 dB below the highest emission level within the authorized band. If the output power of this device was measured by spectrum analyzer, the attenuation under this paragraph shall be 30 dB instead of 20 dB. In addition, radiated emissions which fall in the restricted bands must also comply with the limits as below.

Frequency (MHz)	Field Strength (microvolts/meter)	Measurement Distance (meters)
0.009 – 0.490	2400/F(kHz)	300
0.490 – 1.705	24000/F(kHz)	30
1.705 – 30.0	30	30
30 – 88	100	3
88 – 216	150	3
216 - 960	200	3
Above 960	500	3

3.5.2 Measuring Instruments

See list of measuring equipment of this test report.



3.5.3 Test Procedures

1. The testing follows FCC KDB Publication No. 558074 D01 DTS Meas. Guidance v05.
2. The EUT was arranged to its worst case and then tune the antenna tower (from 1 m to 4 m) and turntable (from 0 degree to 360 degrees) to find the maximum reading. A pre-amp and a high pass filter are used for the test in order to get better signal level.
3. The EUT was placed on a turntable with 0.8 meter for frequency below 1GHz and 1.5 meter for frequency above 1GHz respectively above ground.
4. The EUT was set 3 meters from the interference receiving antenna, which was mounted on the top of a variable height antenna tower.
5. Corrected Reading: Antenna Factor + Cable Loss + Read Level - Preamp Factor = Level
6. For testing below 1GHz, if the emission level of the EUT in peak mode was 3 dB lower than the limit specified, then peak values of EUT will be reported, otherwise, the emissions will be repeated one by one using the CISPR quasi-peak method and reported.
7. For testing above 1GHz, the emission level of the EUT in peak mode was 20dB lower than average limit (that means the emission level in average mode also complies with the limit in average mode), then peak values of EUT will be reported, otherwise, the emissions will be measured in average mode again and reported.
8. Use the following spectrum analyzer settings:
 - (1) Span shall wide enough to fully capture the emission being measured;
 - (2) Set RBW=100 kHz for $f < 1$ GHz; VBW \geq RBW; Sweep = auto; Detector function = peak; Trace = max hold;
 - (3) Set RBW = 1 MHz, VBW= 3MHz for $f \geq 1$ GHz for peak measurement.
For average measurement:
 - VBW = 10 Hz, when duty cycle is no less than 98 percent.
 - VBW $\geq 1/T$, when duty cycle is less than 98 percent where T is the minimum transmission duration over which the transmitter is on and is transmitting at its maximum power control level for the tested mode of operation.

3.5.4 Test Setup

For radiated emissions below 30MHz

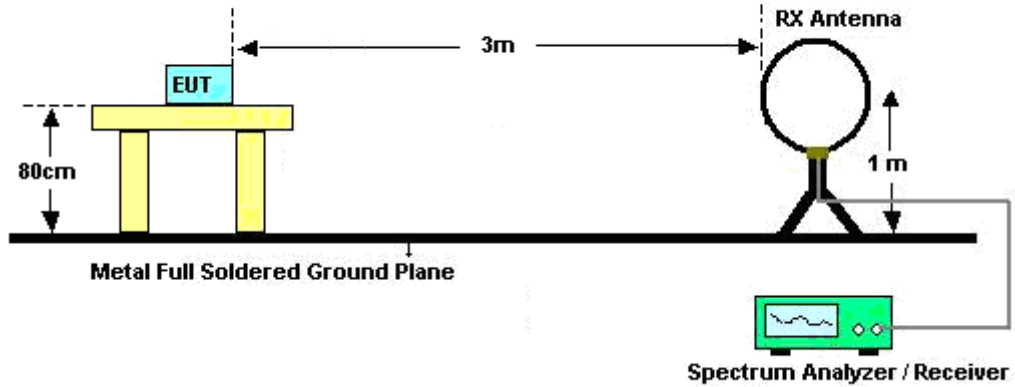

For radiated emissions from 30MHz to 1GHz

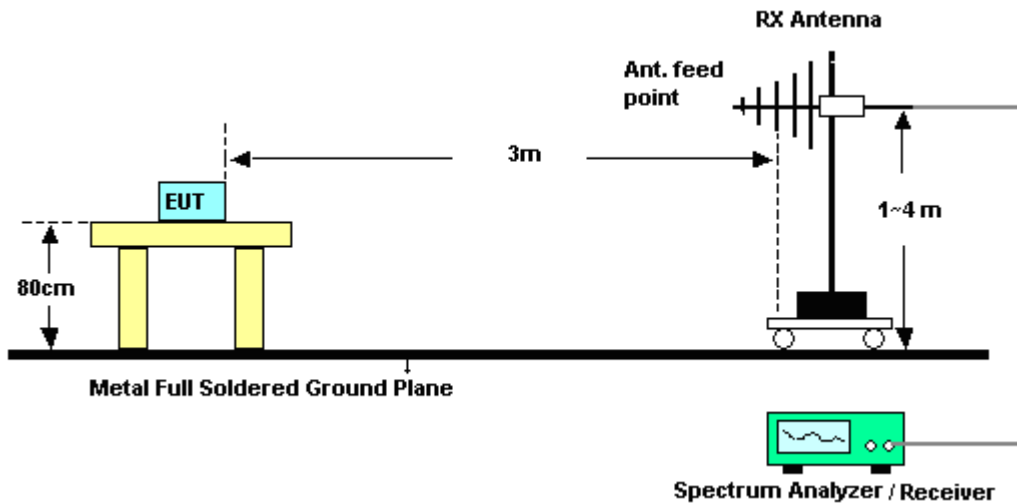

For radiated emissions above 1GHz

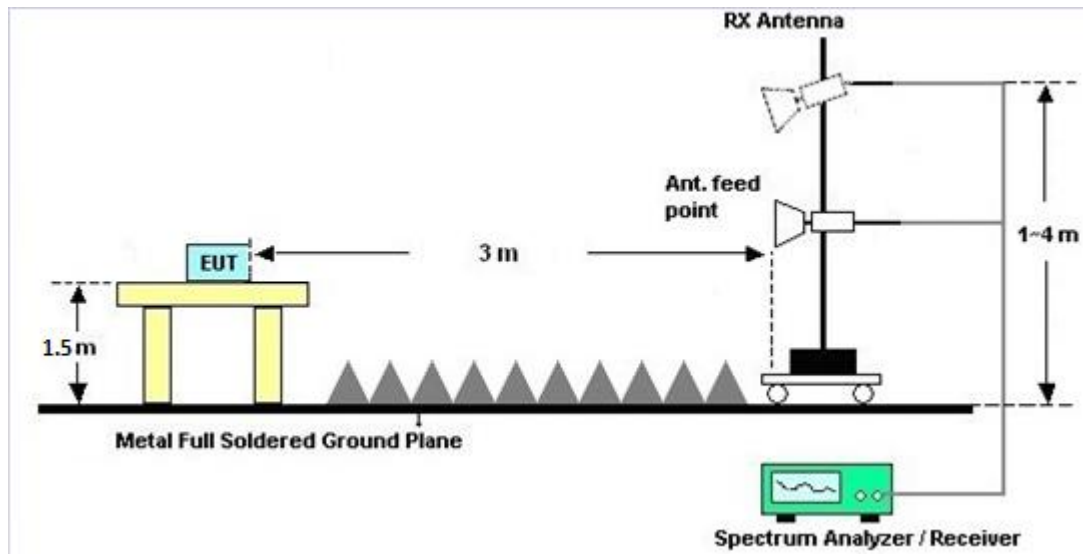

3.5.5 Test Results of Radiated Spurious Emissions (9kHz ~ 30MHz)

The low frequency, which started from 9 kHz to 30MHz, was pre-scanned and the result which was 20dB lower than the limit line was not reported.

There is a comparison data of both open-field test site and alternative test site - semi-Anechoic chamber according to 414788 D01 Radiated Test Site v01r01, and the result came out very similar.

3.5.6 Test Result of Radiated Spurious at Band Edges

Please refer to Appendix C and D.

3.5.7 Duty Cycle

Please refer to Appendix E.

3.5.8 Test Result of Radiated Spurious Emission (30MHz ~ 10th Harmonic)

Please refer to Appendix C and D.

3.6 AC Conducted Emission Measurement

3.6.1 Limit of AC Conducted Emission

For equipment that is designed to be connected to the public utility (AC) power line, the radio frequency voltage that is conducted back onto the AC power line on any frequency or frequencies within the band 150 kHz to 30 MHz shall not exceed the limits in the following table.

Frequency of Emission (MHz)	Conducted Limit (dB μ V)	
	Quasi-Peak	Average
0.15-0.5	66 to 56*	56 to 46*
0.5-5	56	46
5-30	60	50

*Decreases with the logarithm of the frequency.

3.6.2 Measuring Instruments

See list of measuring equipment of this test report.

3.6.3 Test Procedures

1. The EUT was placed 0.4 meter from the conducting wall of the shielding room, and it was kept at least 80 centimeters from any other grounded conducting surface.
2. Connect EUT to the power mains through a line impedance stabilization network (LISN).
3. All the support units are connecting to the other LISN.
4. The LISN provides 50 ohm coupling impedance for the measuring instrument.
5. The FCC states that a 50 ohm, 50 microhenry LISN should be used.
6. Both sides of AC line were checked for maximum conducted interference.
7. The frequency range from 150 kHz to 30 MHz was searched.
8. Set the test-receiver system to Peak Detect Function and specified bandwidth (IF bandwidth = 9kHz) with Maximum Hold Mode.

3.6.5 Test Setup

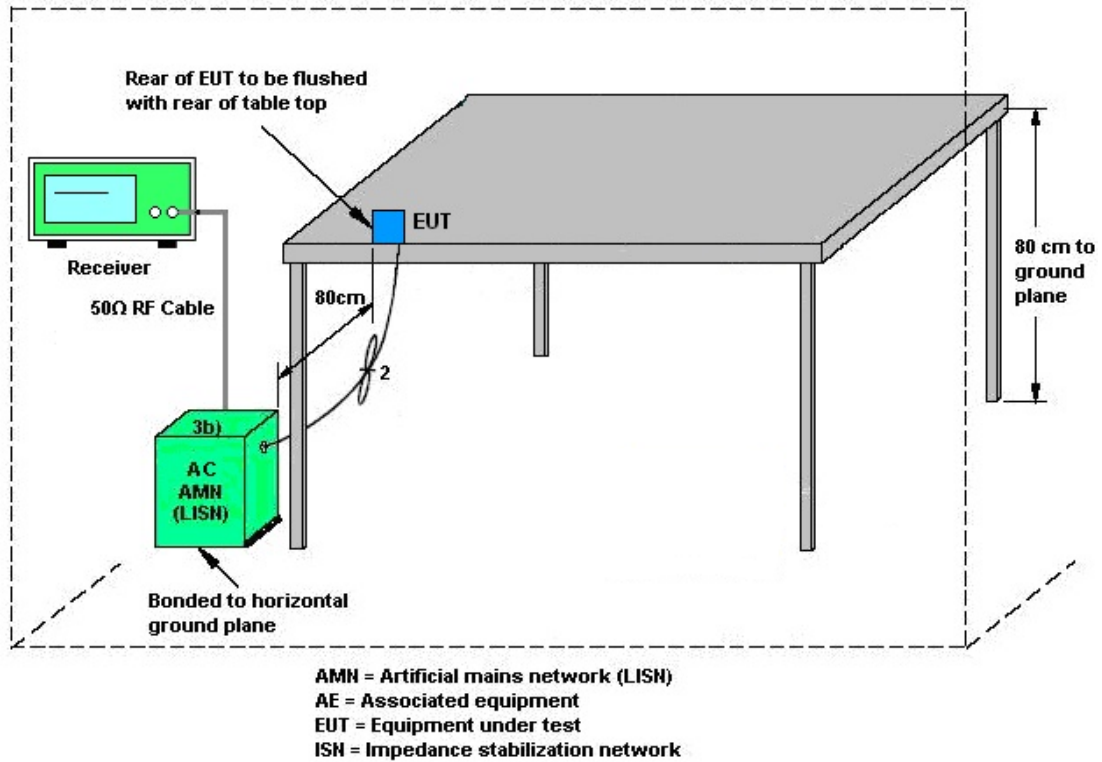

3.6.6 Test Result of AC Conducted Emission

Please refer to Appendix B.

3.7 Antenna Requirements

3.7.1 Standard Applicable

If directional gain of transmitting Antennas is greater than 6dBi, the power shall be reduced by the same level in dB comparing to gain minus 6dBi. The use of a permanently attached Antenna or of an Antenna that uses a unique coupling to the intentional radiator shall be considered sufficient to comply with the rule.

3.7.2 Antenna Anti-Replacement Construction

An embedded-in antenna design is used.

3.7.3 Antenna Gain

<CDD Modes>

FCC KDB 662911 D01 Multiple Transmitter Output v02r01

For CDD transmissions, directional gain is calculated as

Directional gain = G_{ANT} + Array Gain, where Array Gain is as follows.

For power spectral density (PSD) measurements on all devices,

Array Gain = $10 \log(N_{ANT}/N_{SS}=1)$ dB.

For power measurements on IEEE 802.11 devices,

Array Gain = 0 dB (i.e., no array gain) for $N_{ANT} \leq 4$.

Directional gain may be calculated by using the formulas applicable to equal gain antennas with G_{ANT} set equal to the gain of the antenna having the highest gain;

The EUT supports CDD mode.

For power, the directional gain G_{ANT} is set equal to the antenna having the highest gain, i.e., F)2)f)i).

For PSD, the directional gain calculation is following F)2)f)ii) of KDB 662911 D01 v02r01.

The power and PSD limit should be modified if the directional gain of EUT is over 6 dBi,

The directional gain "DG" is calculated as following table.

<CDD Modes>						
			DG	DG	Power	PSD
	Ant. 1	Ant. 2	for	for	Limit	Limit
	(dBi)	(dBi)	Power	PSD	Reduction	Reduction
	(dBi)	(dBi)	(dBi)	(dBi)	(dB)	(dB)
2.4 GHz	1.28	1.41	1.41	4.36	0.00	0.00

$$Power\ Limit\ Reduction = DG(Power) - 6dBi, (min = 0)$$

$$PSD\ Limit\ Reduction = DG(PSD) - 6dBi, (min = 0)$$



4 List of Measuring Equipment

Instrument	Manufacturer	Model No.	Serial No.	Characteristics	Calibration Date	Test Date	Due Date	Remark
Power Meter	Anritsu	ML2495A	1132003	N/A	Aug. 16, 2018	Oct. 03, 2018~ Oct. 22, 2018	Aug. 15, 2019	Conducted (TH05-HY)
Power Sensor	Anritsu	MA2411B	1126017	300MHz~40GHz z	Aug. 16, 2018	Oct. 03, 2018~ Oct. 22, 2018	Aug. 15, 2019	Conducted (TH05-HY)
Spectrum Analyzer	Rohde & Schwarz	FSP30	101067	9kHz ~ 30GHz	Nov. 13, 2017	Oct. 03, 2018~ Oct. 22, 2018	Nov. 12, 2018	Conducted (TH05-HY)
Switch Box & RF Cable	Burgeon	ETF-058	EC130048 4	N/A	Mar. 01, 2018	Oct. 03, 2018~ Oct. 22, 2018	Feb. 28, 2019	Conducted (TH05-HY)
Horn Antenna	SCHWARZBECK	BBHA 9120 D	9120D-124 1	1GHz ~ 18GHz	Jun. 29, 2018	Oct. 02, 2018~ Oct. 18, 2018	Jun. 28, 2019	Radiation (03CH13-HY)
Loop Antenna	Rohde & Schwarz	HFH2-Z2	100315	9 kHz~30 MHz	Nov. 10, 2017	Oct. 02, 2018~ Oct. 18, 2018	Nov. 09, 2018	Radiation (03CH13-HY)
Amplifier	MITEQ	TTA1840-35-HG	1871923	18GHz~40GHz, VSWR : 2.5:1 max	Jul. 16, 2018	Oct. 02, 2018~ Oct. 18, 2018	Jul. 15, 2019	Radiation (03CH13-HY)
Filter	Wainwright	WLKS1200-8SS	SN3	1G Low pass Filter	Nov. 21, 2017	Oct. 02, 2018~ Oct. 18, 2018	Nov. 22, 2018	Radiation (03CH13-HY)
Filter	Wainwright	WHKX12-270 0-3000-18000 -60ST	SN5	3G High Pass	Mar. 08, 2018	Oct. 02, 2018~ Oct. 18, 2018	Mar. 07, 2019	Radiation (03CH13-HY)
Amplifier	Sonoma-Instrument	310 N	187282	9KHz~1GHz	Jan. 19, 2018	Oct. 02, 2018~ Oct. 18, 2018	Jan. 18, 2020	Radiation (03CH13-HY)
Bilog Antenna	TESEQ	CBL 6111D&00800 N1D01N-06	40103&07	30MHz to 1GHz	Jan. 10, 2018	Oct. 02, 2018~ Oct. 18, 2018	Jan. 09, 2019	Radiation (03CH13-HY)
Preamplifier	Jet-Power	JPA0118-55-303	171000180 0054001	1GHz~18GHz	Apr. 16, 2018	Oct. 02, 2018~ Oct. 18, 2018	Apr. 15, 2019	Radiation (03CH13-HY)
Preamplifier	Keysight	83017A	MY532701 47	1GHz~26.5GHz	Feb. 02, 2018	Oct. 02, 2018~ Oct. 18, 2018	Feb. 01, 2019	Radiation (03CH13-HY)
Spectrum Analyzer	Keysight	N9010A	MY553705 26	10Hz~44GHz	Mar. 15, 2018	Oct. 02, 2018~ Oct. 18, 2018	Mar. 14, 2019	Radiation (03CH13-HY)
Antenna Mast	EMEC	AM-BS-4500-B	N/A	1m~4m	N/A	Oct. 02, 2018~ Oct. 18, 2018	N/A	Radiation (03CH13-HY)
Turn Table	EMEC	TT2000	N/A	0~360 Degree	N/A	Oct. 02, 2018~ Oct. 18, 2018	N/A	Radiation (03CH13-HY)
SHF-EHF Horn Antenna	SCHWARZBECK	BBHA 9170	BBHA9170 584	18GHz- 40GHz	Nov. 27, 2017	Oct. 02, 2018~ Oct. 18, 2018	Nov. 26, 2018	Radiation (03CH13-HY)
EMI Test Receiver	Agilent	N9038A (MXE)	MY532900 53	20Hz to 26.5GHz	Jan. 16, 2018	Oct. 02, 2018~ Oct. 18, 2018	Jan. 15, 2019	Radiation (03CH13-HY)
RF Cable	HUBER + SUHNER	SUCOFLEX 126E	0030/126E	30M-18G	Jan. 22, 2018	Oct. 02, 2018~ Oct. 18, 2018	Jan. 21, 2019	Radiation (03CH13-HY)
RF Cable	HUBER + SUHNER	SUCOFLEX 104	335041/4	30M-18G	Jan. 22, 2018	Oct. 02, 2018~ Oct. 18, 2018	Jan. 21, 2019	Radiation (03CH13-HY)
RF Cable	HUBER + SUHNER	SUCOFLEX 104	MY24961/ 4	30M~18GHz	Jan. 22, 2018	Oct. 02, 2018~ Oct. 18, 2018	Jan. 21, 2019	Radiation (03CH13-HY)
RF Cable	HUBER + SUHNER	SUCOFLEX 102	MY2859/2	30M~40GHz	Mar. 14, 2018	Oct. 02, 2018~ Oct. 18, 2018	Mar. 13, 2019	Radiation (03CH13-HY)
RF Cable	HUBER + SUHNER	SUCOFLEX 102	MY4274/2	30M~40GHz	Mar. 14, 2018	Oct. 02, 2018~ Oct. 18, 2018	Mar. 13, 2019	Radiation (03CH13-HY)
Software	AUDIX	E3 6.2009-8-24c	RK-001124	N/A	N/A	Oct. 02, 2018~ Oct. 18, 2018	N/A	Radiation (03CH13-HY)



Instrument	Manufacturer	Model No.	Serial No.	Characteristics	Calibration Date	Test Date	Due Date	Remark
AC Power Source	ChainTek	APC-1000W	N/A	N/A	N/A	Oct. 15, 2018	N/A	Conduction (CO05-HY)
EMI Test Receiver	Rohde & Schwarz	ESR3	102388	9KHz~3.6GHz	Dec. 08, 2017	Oct. 15, 2018	Dec. 07, 2018	Conduction (CO05-HY)
ISN	TESEQ	ISN T8-Cat6	38909	N/A	Jan. 29, 2018	Oct. 15, 2018	Jan. 28, 2019	Conduction (CO05-HY)
LISN	Rohde & Schwarz	ENV216	100080	9kHz~30MHz	Nov. 30, 2017	Oct. 15, 2018	Nov. 29, 2018	Conduction (CO05-HY)
LISN	Rohde & Schwarz	ENV216	100081	9kHz~30MHz	Dec. 08, 2017	Oct. 15, 2018	Dec. 07, 2018	Conduction (CO05-HY)
Software	Rohde & Schwarz	EMC32 V10.30	N/A	N/A	N/A	Oct. 15, 2018	N/A	Conduction (CO05-HY)
LF Cable	HUBER + SUHNER	RG-214/U	LF01	N/A	Jan. 03, 2018	Oct. 15, 2018	Jan. 02, 2019	Conduction (CO05-HY)
Pulse Limiter	Rohde & Schwarz	ESH3-Z2	100851	N/A	Jan. 03, 2018	Oct. 15, 2018	Jan. 02, 2019	Conduction (CO05-HY)



5 Uncertainty of Evaluation

Uncertainty of Conducted Emission Measurement (150kHz ~ 30MHz)

Measuring Uncertainty for a Level of Confidence of 95% ($U = 2Uc(y)$)	2.2
---	-----

Uncertainty of Radiated Emission Measurement (30 MHz ~ 1000 MHz)

Measuring Uncertainty for a Level of Confidence of 95% ($U = 2Uc(y)$)	4.9
---	-----

Uncertainty of Radiated Emission Measurement (1000 MHz ~ 18000 MHz)

Measuring Uncertainty for a Level of Confidence of 95% ($U = 2Uc(y)$)	5.4
---	-----

Uncertainty of Radiated Emission Measurement (18000 MHz ~ 40000 MHz)

Measuring Uncertainty for a Level of Confidence of 95% ($U = 2Uc(y)$)	4.3
---	-----

Appendix A. Test Result of Conducted Test Items

Test Engineer:	Luffy Lin / Allen Lin	Temperature:	21~25	°C
Test Date:	2018/10/3~2018/10/22	Relative Humidity:	51~54	%

TEST RESULTS DATA
6dB and 99% Occupied Bandwidth

2.4GHz Band										
Mod.	Data Rate	N _{TX}	CH.	Freq. (MHz)	99% Occupied BW (MHz)		6dB BW (MHz)		6dB BW Limit (MHz)	Pass/Fail
					Ant 1	Ant 2	Ant 1	Ant 2		
11b	1Mbps	1	1	2412	14.05	14.00	9.08	9.06	0.50	Pass
11b	1Mbps	1	6	2437	13.80	14.05	9.06	9.04	0.50	Pass
11b	1Mbps	1	11	2462	13.75	13.70	9.04	9.04	0.50	Pass
11b	1Mbps	1	12	2467	13.60	13.50	9.02	8.52	0.50	Pass
11b	1Mbps	1	13	2472	13.45	13.50	9.06	9.06	0.50	Pass
11g	6Mbps	1	1	2412	16.70	16.75	15.10	15.12	0.50	Pass
11g	6Mbps	1	6	2437	16.90	17.20	15.10	15.00	0.50	Pass
11g	6Mbps	1	11	2462	16.70	16.60	15.10	15.12	0.50	Pass
11g	6Mbps	1	12	2467	16.60	16.60	15.12	15.08	0.50	Pass
11g	6Mbps	1	13	2472	16.60	16.60	15.12	15.10	0.50	Pass
HT20	MCS0	1	1	2412	17.75	17.70	15.06	15.12	0.50	Pass
HT20	MCS0	1	6	2437	17.95	17.85	15.10	15.12	0.50	Pass
HT20	MCS0	1	11	2462	17.70	17.65	15.12	15.10	0.50	Pass
HT20	MCS0	1	12	2467	17.65	17.65	15.04	15.12	0.50	Pass
HT20	MCS0	1	13	2472	17.65	17.65	15.10	15.12	0.50	Pass
11b	1Mbps	2	1	2412	14.20	13.85	9.06	9.06	0.50	Pass
11b	1Mbps	2	6	2437	13.75	13.55	9.06	8.02	0.50	Pass
11b	1Mbps	2	11	2462	13.70	13.45	9.08	8.60	0.50	Pass
11b	1Mbps	2	12	2467	13.60	13.45	9.08	9.06	0.50	Pass
11b	1Mbps	2	13	2472	13.55	13.70	8.54	9.04	0.50	Pass
11g	6Mbps	2	1	2412	16.75	16.50	15.10	15.12	0.50	Pass
11g	6Mbps	2	6	2437	17.05	16.80	15.12	15.12	0.50	Pass
11g	6Mbps	2	11	2462	16.65	16.45	15.08	15.12	0.50	Pass
11g	6Mbps	2	12	2467	16.60	16.50	15.10	15.04	0.50	Pass
11g	6Mbps	2	13	2472	16.60	16.45	15.10	15.12	0.50	Pass
HT20	MCS0	2	1	2412	17.65	17.55	15.12	15.72	0.50	Pass
HT20	MCS0	2	6	2437	18.00	17.75	15.12	15.70	0.50	Pass
HT20	MCS0	2	11	2462	17.70	17.55	15.12	15.70	0.50	Pass
HT20	MCS0	2	12	2467	17.70	17.55	15.04	16.32	0.50	Pass
HT20	MCS0	2	13	2472	17.65	17.55	15.12	16.32	0.50	Pass

TEST RESULTS DATA
Peak Output Power

2.4GHz Band																
Mod.	Data Rate	NTx	CH.	Freq. (MHz)	Peak Conducted Power (dBm)			Conducted Power Limit (dBm)		DG (dBi)		EIRP Power (dBm)		EIRP Power Limit (dBm)		Pass /Fail
					Ant 1	Ant 2	SUM	Ant 1	Ant 2	Ant 1	Ant 2	Ant 1	Ant 2	Ant 1	Ant 2	
11b	1Mbps	1	1	2412	23.02	24.47	-	30.00	30.00	1.28	1.41	24.30	25.88	36.00	36.00	Pass
11b	1Mbps	1	6	2437	21.71	24.38	-	30.00	30.00	1.28	1.41	22.99	25.79	36.00	36.00	Pass
11b	1Mbps	1	11	2462	21.42	22.66	-	30.00	30.00	1.28	1.41	22.70	24.07	36.00	36.00	Pass
11b	1Mbps	1	12	2467	19.78	21.53	-	30.00	30.00	1.28	1.41	21.06	22.94	36.00	36.00	Pass
11b	1Mbps	1	13	2472	16.52	16.64	-	30.00	30.00	1.28	1.41	17.80	18.05	36.00	36.00	Pass
11g	6Mbps	1	1	2412	25.00	25.12	-	30.00	30.00	1.28	1.41	26.28	26.53	36.00	36.00	Pass
11g	6Mbps	1	6	2437	25.08	25.67	-	30.00	30.00	1.28	1.41	26.36	27.08	36.00	36.00	Pass
11g	6Mbps	1	11	2462	24.41	24.49	-	30.00	30.00	1.28	1.41	25.69	25.90	36.00	36.00	Pass
11g	6Mbps	1	12	2467	22.78	23.53	-	30.00	30.00	1.28	1.41	24.06	24.94	36.00	36.00	Pass
11g	6Mbps	1	13	2472	20.05	19.77	-	30.00	30.00	1.28	1.41	21.33	21.18	36.00	36.00	Pass
HT20	MCS0	1	1	2412	24.71	25.23	-	30.00	30.00	1.28	1.41	25.99	26.64	36.00	36.00	Pass
HT20	MCS0	1	6	2437	25.11	25.68	-	30.00	30.00	1.28	1.41	26.39	27.09	36.00	36.00	Pass
HT20	MCS0	1	11	2462	24.62	24.85	-	30.00	30.00	1.28	1.41	25.90	26.26	36.00	36.00	Pass
HT20	MCS0	1	12	2467	21.92	24.51	-	30.00	30.00	1.28	1.41	23.20	25.92	36.00	36.00	Pass
HT20	MCS0	1	13	2472	20.87	20.68	-	30.00	30.00	1.28	1.41	22.15	22.09	36.00	36.00	Pass
11b	1Mbps	2	1	2412	23.16	23.53	26.36	30.00	30.00	1.41	1.41	27.77	27.77	36.00	36.00	Pass
11b	1Mbps	2	6	2437	21.26	21.64	24.46	30.00	30.00	1.41	1.41	25.87	25.87	36.00	36.00	Pass
11b	1Mbps	2	11	2462	20.99	20.52	23.77	30.00	30.00	1.41	1.41	25.18	25.18	36.00	36.00	Pass
11b	1Mbps	2	12	2467	20.44	20.17	23.32	30.00	30.00	1.41	1.41	24.73	24.73	36.00	36.00	Pass
11b	1Mbps	2	13	2472	18.17	18.15	21.17	30.00	30.00	1.41	1.41	22.58	22.58	36.00	36.00	Pass
11g	6Mbps	2	1	2412	24.31	24.71	27.52	30.00	30.00	1.41	1.41	28.93	28.93	36.00	36.00	Pass
11g	6Mbps	2	6	2437	24.81	25.48	28.17	30.00	30.00	1.41	1.41	29.58	29.58	36.00	36.00	Pass
11g	6Mbps	2	11	2462	24.05	24.11	27.09	30.00	30.00	1.41	1.41	28.50	28.50	36.00	36.00	Pass
11g	6Mbps	2	12	2467	20.83	20.62	23.74	30.00	30.00	1.41	1.41	25.15	25.15	36.00	36.00	Pass
11g	6Mbps	2	13	2472	19.36	19.45	22.42	30.00	30.00	1.41	1.41	23.83	23.83	36.00	36.00	Pass
HT20	MCS0	2	1	2412	24.26	24.97	27.64	30.00	30.00	1.41	1.41	29.05	29.05	36.00	36.00	Pass
HT20	MCS0	2	6	2437	25.14	25.51	28.34	30.00	30.00	1.41	1.41	29.75	29.75	36.00	36.00	Pass
HT20	MCS0	2	11	2462	23.85	24.46	27.18	30.00	30.00	1.41	1.41	28.59	28.59	36.00	36.00	Pass
HT20	MCS0	2	12	2467	21.04	21.31	24.19	30.00	30.00	1.41	1.41	25.60	25.60	36.00	36.00	Pass
HT20	MCS0	2	13	2472	19.62	20.21	22.94	30.00	30.00	1.41	1.41	24.35	24.35	36.00	36.00	Pass

Note: Measured power (dBm) has offset with cable loss.

TEST RESULTS DATA
Average Output Power

2.4GHz Band									
Mod.	Data Rate	NTX	CH.	Freq. (MHz)	Duty Factor (dB)		Average Conducted Power (dBm)		
					Ant 1	Ant 2	Ant 1	Ant 2	SUM
11b	1Mbps	1	1	2412	0.06	0.05	20.97	22.52	-
11b	1Mbps	1	6	2437	0.06	0.05	19.69	22.38	
11b	1Mbps	1	11	2462	0.06	0.05	19.38	20.60	
11b	1Mbps	1	12	2467	0.06	0.05	17.71	19.45	
11b	1Mbps	1	13	2472	0.06	0.05	14.44	14.51	
11g	6Mbps	1	1	2412	0.30	0.30	17.75	17.62	
11g	6Mbps	1	6	2437	0.30	0.30	19.09	19.88	
11g	6Mbps	1	11	2462	0.30	0.30	16.59	16.25	
11g	6Mbps	1	12	2467	0.30	0.30	13.35	14.14	
11g	6Mbps	1	13	2472	0.30	0.30	10.35	9.98	
HT20	MCS0	1	1	2412	0.32	0.32	17.20	16.54	
HT20	MCS0	1	6	2437	0.32	0.32	18.47	18.84	
HT20	MCS0	1	11	2462	0.32	0.32	15.45	16.00	
HT20	MCS0	1	12	2467	0.32	0.32	11.83	15.04	
HT20	MCS0	1	13	2472	0.32	0.32	9.77	9.77	
11b	1Mbps	2	1	2412	0.06	0.06	21.17	21.51	24.35
11b	1Mbps	2	6	2437	0.06	0.06	19.10	19.51	22.32
11b	1Mbps	2	11	2462	0.06	0.06	18.93	18.51	21.74
11b	1Mbps	2	12	2467	0.06	0.06	18.39	17.97	21.20
11b	1Mbps	2	13	2472	0.06	0.06	16.10	16.13	19.13
11g	6Mbps	2	1	2412	0.30	0.30	16.20	16.66	19.45
11g	6Mbps	2	6	2437	0.30	0.30	19.37	19.67	22.53
11g	6Mbps	2	11	2462	0.30	0.30	15.62	15.35	18.50
11g	6Mbps	2	12	2467	0.30	0.30	11.48	11.52	14.51
11g	6Mbps	2	13	2472	0.30	0.30	9.56	9.47	12.53
HT20	MCS0	2	1	2412	0.32	0.39	15.09	15.87	18.51
HT20	MCS0	2	6	2437	0.32	0.39	18.78	18.92	21.86
HT20	MCS0	2	11	2462	0.32	0.39	14.34	15.11	17.75
HT20	MCS0	2	12	2467	0.32	0.39	10.85	11.81	14.37
HT20	MCS0	2	13	2472	0.32	0.39	8.30	9.21	11.79

Note: Measured power (dBm) has offset with cable loss.

TEST RESULTS DATA
Peak Power Spectral Density

2.4GHz Band												
Mod.	Data Rate	N _{TX}	CH.	Freq. (MHz)	Peak PSD (dBm/3kHz)			DG (dBi)		Peak PSD Limit (dBm/3kHz)		Pass/Fail
					Ant 1	Ant 2	Worse + 3.01	Ant 1	Ant 2	Ant 1	Ant 2	
11b	1Mbps	1	1	2412	-1.29	0.54	-	1.28	1.41	8.00	8.00	Pass
11b	1Mbps	1	6	2437	-3.47	-0.47	-	1.28	1.41	8.00	8.00	Pass
11b	1Mbps	1	11	2462	-3.34	-3.04	-	1.28	1.41	8.00	8.00	Pass
11b	1Mbps	1	12	2467	-4.48	-3.33	-	1.28	1.41	8.00	8.00	Pass
11b	1Mbps	1	13	2472	-7.91	-8.11	-	1.28	1.41	8.00	8.00	Pass
11g	6Mbps	1	1	2412	-9.07	-9.43	-	1.28	1.41	8.00	8.00	Pass
11g	6Mbps	1	6	2437	-7.50	-7.77	-	1.28	1.41	8.00	8.00	Pass
11g	6Mbps	1	11	2462	-9.14	-10.71	-	1.28	1.41	8.00	8.00	Pass
11g	6Mbps	1	12	2467	-14.48	-12.80	-	1.28	1.41	8.00	8.00	Pass
11g	6Mbps	1	13	2472	-16.92	-17.08	-	1.28	1.41	8.00	8.00	Pass
HT20	MCS0	1	1	2412	-9.49	-10.69	-	1.28	1.41	8.00	8.00	Pass
HT20	MCS0	1	6	2437	-6.78	-7.92	-	1.28	1.41	8.00	8.00	Pass
HT20	MCS0	1	11	2462	-11.95	-11.37	-	1.28	1.41	8.00	8.00	Pass
HT20	MCS0	1	12	2467	-13.80	-11.57	-	1.28	1.41	8.00	8.00	Pass
HT20	MCS0	1	13	2472	-14.85	-16.59	-	1.28	1.41	8.00	8.00	Pass
11b	1Mbps	2	1	2412	-2.11	-1.69	1.32	4.36		8.00		Pass
11b	1Mbps	2	6	2437	-3.64	-4.91	-0.63	4.36		8.00		Pass
11b	1Mbps	2	11	2462	-4.60	-4.92	-1.59	4.36		8.00		Pass
11b	1Mbps	2	12	2467	-4.26	-5.95	-1.25	4.36		8.00		Pass
11b	1Mbps	2	13	2472	-5.92	-6.40	-2.91	4.36		8.00		Pass
11g	6Mbps	2	1	2412	-9.77	-9.70	-6.69	4.36		8.00		Pass
11g	6Mbps	2	6	2437	-7.99	-7.73	-4.72	4.36		8.00		Pass
11g	6Mbps	2	11	2462	-11.38	-11.26	-8.25	4.36		8.00		Pass
11g	6Mbps	2	12	2467	-16.35	-15.76	-12.75	4.36		8.00		Pass
11g	6Mbps	2	13	2472	-17.71	-17.07	-14.06	4.36		8.00		Pass
HT20	MCS0	2	1	2412	-11.50	-10.15	-7.14	4.36		8.00		Pass
HT20	MCS0	2	6	2437	-7.73	-7.68	-4.67	4.36		8.00		Pass
HT20	MCS0	2	11	2462	-11.76	-11.76	-8.75	4.36		8.00		Pass
HT20	MCS0	2	12	2467	-15.56	-14.58	-11.57	4.36		8.00		Pass
HT20	MCS0	2	13	2472	-18.52	-17.39	-14.38	4.36		8.00		Pass

Measured power density (dBm) has offset with cable loss.



Appendix B. AC Conducted Emission Test Results

Test Engineer :	Rick Lin	Temperature :	24~26°C
		Relative Humidity :	55~58%

EUT Information

Report NO : 842410-01
 Test Mode : Mode 1
 Test Voltage : 120Vac/60Hz
 Phase : Line

Full Spectrum

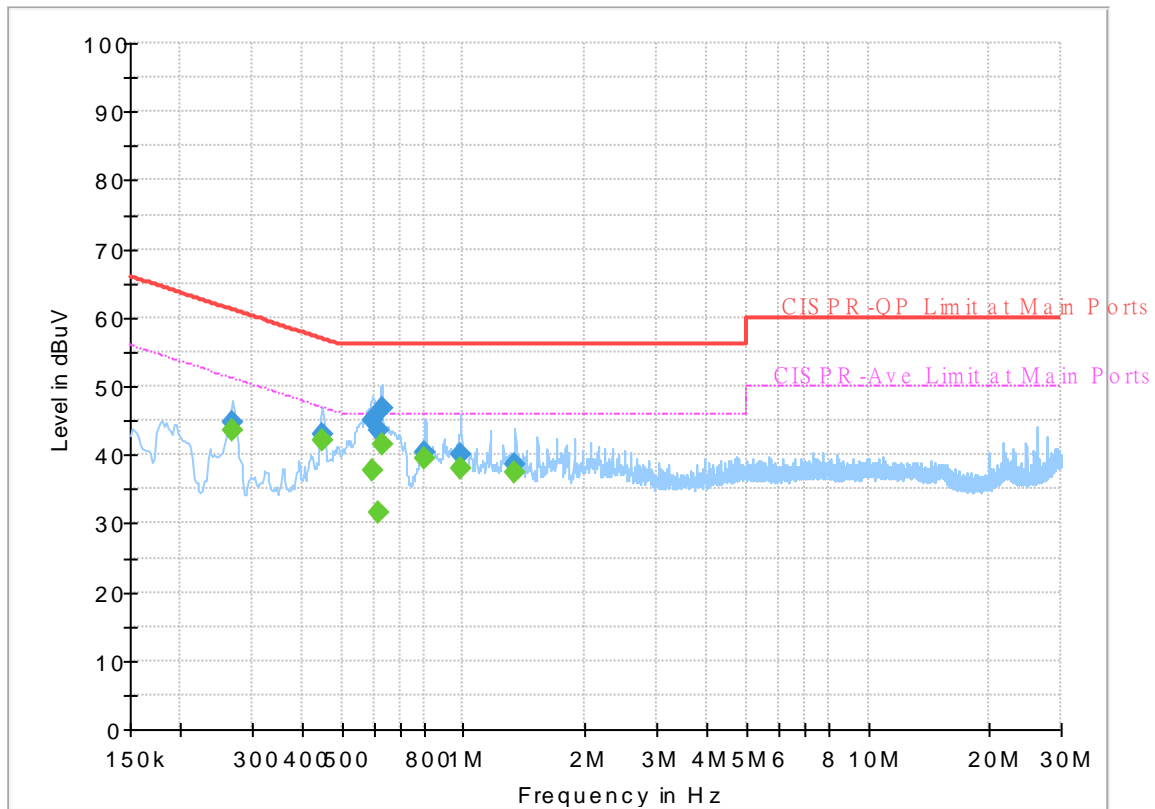

Final_Result

Frequency (MHz)	QuasiPeak (dBuV)	CAverage (dBuV)	Limit (dBuV)	Margin (dB)	Line	Filter	Corr. (dB)
0.269250	---	43.66	51.14	7.48	L1	OFF	19.5
0.269250	44.83	---	61.14	16.31	L1	OFF	19.5
0.447000	---	42.23	46.93	4.70	L1	OFF	19.5
0.447000	42.87	---	56.93	14.06	L1	OFF	19.5
0.597750	---	37.62	46.00	8.38	L1	OFF	19.5
0.597750	45.06	---	56.00	10.94	L1	OFF	19.5
0.613500	---	31.60	46.00	14.40	L1	OFF	19.6
0.613500	43.56	---	56.00	12.44	L1	OFF	19.6
0.627000	---	41.63	46.00	4.37	L1	OFF	19.6
0.627000	46.72	---	56.00	9.28	L1	OFF	19.6
0.804750	---	39.53	46.00	6.47	L1	OFF	19.6
0.804750	40.47	---	56.00	15.53	L1	OFF	19.6
0.982500	---	37.89	46.00	8.11	L1	OFF	19.6
0.982500	40.03	---	56.00	15.97	L1	OFF	19.6
1.342500	---	37.44	46.00	8.56	L1	OFF	19.6
1.342500	38.67	---	56.00	17.33	L1	OFF	19.6

EUT Information

Report NO : 842410-01
 Test Mode : Mode 1
 Test Voltage : 120Vac/60Hz
 Phase : Neutral

Full Spectrum

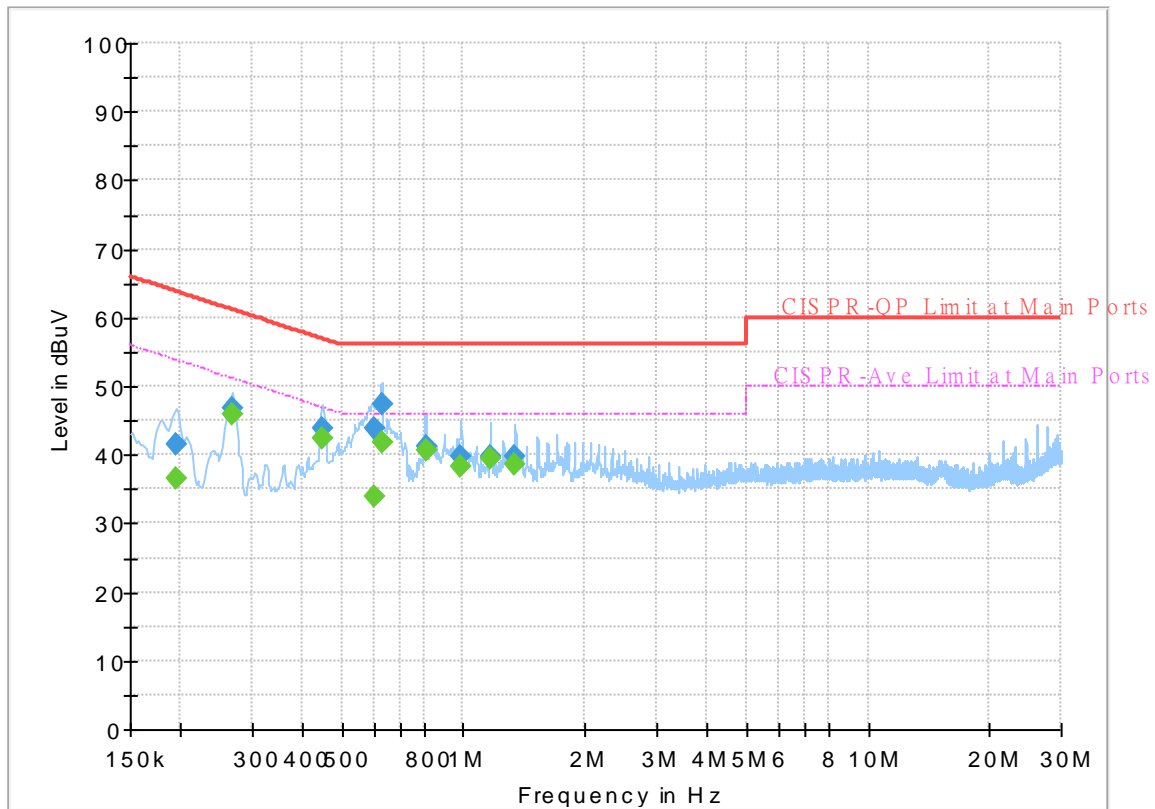

Final_Result

Frequency (MHz)	QuasiPeak (dBuV)	CAverage (dBuV)	Limit (dBuV)	Margin (dB)	Line	Filter	Corr. (dB)
0.195000	---	36.65	53.82	17.17	N	OFF	19.5
0.195000	41.46	---	63.82	22.36	N	OFF	19.5
0.269250	---	45.88	51.14	5.26	N	OFF	19.5
0.269250	46.75	---	61.14	14.39	N	OFF	19.5
0.449250	---	42.30	46.89	4.59	N	OFF	19.5
0.449250	43.87	---	56.89	13.02	N	OFF	19.5
0.600000	---	33.84	46.00	12.16	N	OFF	19.6
0.600000	43.92	---	56.00	12.08	N	OFF	19.6
0.627000	---	41.78	46.00	4.22	N	OFF	19.6
0.627000	47.45	---	56.00	8.55	N	OFF	19.6
0.807000	---	40.65	46.00	5.35	N	OFF	19.6
0.807000	41.28	---	56.00	14.72	N	OFF	19.6
0.982500	---	38.35	46.00	7.65	N	OFF	19.6
0.982500	39.77	---	56.00	16.23	N	OFF	19.6
1.164750	---	39.44	46.00	6.56	N	OFF	19.6
1.164750	39.80	---	56.00	16.20	N	OFF	19.6
1.342500	---	38.63	46.00	7.37	N	OFF	19.6
1.342500	39.74	---	56.00	16.26	N	OFF	19.6



Appendix C. Radiated Spurious Emission

Test Engineer :	Alex Jheng, Fu Chen, and Wilson Wu	Temperature :	24~25°C
		Relative Humidity :	50~52%

2.4GHz 2400~2483.5MHz

WIFI 802.11b (Band Edge @ 3m)

WIFI	Note	Frequency	Level	Over	Limit	Read	Antenna	Path	Preamp	Ant	Table	Peak	Pol.
Ant.				Limit	Line	Level	Factor	Loss	Factor	Pos	Pos	Avg.	
1		(MHz)	(dBμV/m)	(dB)	(dBμV/m)	(dBμV)	(dB/m)	(dB)	(dB)	(cm)	(deg)	(P/A)	(H/V)
802.11b CH 01 2412MHz		2389.8	55.1	-18.9	74	42.27	27.23	15.49	29.89	284	308	P	H
		2390	45.19	-8.81	54	32.36	27.23	15.49	29.89	284	308	A	H
	*	2412	112.47	-	-	99.55	27.28	15.53	29.89	284	308	P	H
	*	2412	109.33	-	-	96.41	27.28	15.53	29.89	284	308	A	H
		2384.55	54.98	-19.02	74	42.2	27.19	15.49	29.9	204	269	P	V
		2389.905	44.25	-9.75	54	31.42	27.23	15.49	29.89	204	269	A	V
	*	2412	111.4	-	-	98.48	27.28	15.53	29.89	204	269	P	V
	*	2412	108.22	-	-	95.3	27.28	15.53	29.89	204	269	A	V
802.11b CH 06 2437MHz		2330.44	53.08	-20.92	74	40.51	27.05	15.43	29.91	277	309	P	H
		2385.74	42.82	-11.18	54	30	27.23	15.49	29.9	277	309	A	H
	*	2437	110.48	-	-	97.45	27.37	15.55	29.89	277	309	P	H
	*	2437	107.32	-	-	94.29	27.37	15.55	29.89	277	309	A	H
		2498.04	54.22	-19.78	74	40.98	27.5	15.61	29.87	277	309	P	H
		2487.75	43.35	-10.65	54	30.12	27.5	15.61	29.88	277	309	A	H
		2367.54	53.6	-20.4	74	40.89	27.14	15.47	29.9	230	268	P	V
		2388.96	42.82	-11.18	54	30	27.23	15.49	29.9	230	268	A	V
	*	2437	110.99	-	-	97.96	27.37	15.55	29.89	230	268	P	V
	*	2437	107.8	-	-	94.77	27.37	15.55	29.89	230	268	A	V
		2491.88	54	-20	74	40.76	27.5	15.61	29.87	230	268	P	V
		2486	43.4	-10.6	54	30.21	27.46	15.61	29.88	230	268	A	V



802.11b CH 11 2462MHz	*	2462	111.67	-	-	98.57	27.41	15.57	29.88	274	302	P	H
	*	2462	108.5	-	-	95.4	27.41	15.57	29.88	274	302	A	H
		2487.12	55.5	-18.5	74	42.31	27.46	15.61	29.88	274	302	P	H
		2483.56	44.43	-9.57	54	31.24	27.46	15.61	29.88	274	302	A	H
	*	2462	111.14	-	-	98.04	27.41	15.57	29.88	287	244	P	V
	*	2462	108.06	-	-	94.96	27.41	15.57	29.88	287	244	A	V
		2489.52	54.84	-19.16	74	41.61	27.5	15.61	29.88	287	244	P	V
		2483.52	44.17	-9.83	54	30.98	27.46	15.61	29.88	287	244	A	V
802.11b CH 12 2467MHz	*	2467	108.4	-	-	95.28	27.41	15.59	29.88	229	308	P	H
	*	2467	105.35	-	-	92.23	27.41	15.59	29.88	229	308	A	H
		2483.8	59.37	-14.63	74	46.18	27.46	15.61	29.88	229	308	P	H
		2484.04	51.52	-2.48	54	38.33	27.46	15.61	29.88	229	308	A	H
	*	2467	109.5	-	-	96.38	27.41	15.59	29.88	224	269	P	V
	*	2467	106.36	-	-	93.24	27.41	15.59	29.88	224	269	A	V
		2483.76	59.81	-14.19	74	46.62	27.46	15.61	29.88	224	269	P	V
		2484.08	52.67	-1.33	54	39.48	27.46	15.61	29.88	224	269	A	V
802.11b CH 13 2472MHz	*	2472	105.19	-	-	92.02	27.46	15.59	29.88	229	305	P	H
	*	2472	102.07	-	-	88.9	27.46	15.59	29.88	229	305	A	H
		2485	57.85	-16.15	74	44.66	27.46	15.61	29.88	229	305	P	H
		2487.24	51.4	-2.6	54	38.21	27.46	15.61	29.88	229	305	A	H
	*	2472	106.78	-	-	93.61	27.46	15.59	29.88	242	253	P	V
	*	2472	103.61	-	-	90.44	27.46	15.59	29.88	242	253	A	V
		2486.92	58.91	-15.09	74	45.72	27.46	15.61	29.88	242	253	P	V
		2487.28	53.02	-0.98	54	39.83	27.46	15.61	29.88	242	253	A	V
Remark	1. No other spurious found. 2. All results are PASS against Peak and Average limit line.												



**2.4GHz 2400~2483.5MHz
WIFI 802.11b (Harmonic @ 3m)**

WIFI Ant. 1	Note	Frequency (MHz)	Level (dBµV/m)	Over Limit (dB)	Limit Line (dBµV/m)	Read Level (dBµV)	Antenna Factor (dB/m)	Path Loss (dB)	Preamp Factor (dB)	Ant Pos (cm)	Table Pos (deg)	Peak Avg. (P/A)	Pol. (H/V)
802.11b CH 01 2412MHz		4824	54.01	-19.99	74	73.05	31.26	8.27	58.57	386	160	P	H
		4824	52.86	-1.14	54	71.9	31.26	8.27	58.57	386	160	A	H
		4824	52.26	-21.74	74	71.3	31.26	8.27	58.57	100	209	P	V
		4824	50.28	-3.72	54	69.32	31.26	8.27	58.57	100	209	A	V
802.11b CH 06 2437MHz		4874	52	-22	74	70.7	31.36	8.49	58.55	400	162	P	H
		4874	50.43	-3.57	54	69.13	31.36	8.49	58.55	400	162	A	H
		7311	56.41	-17.59	74	68.38	36.18	10.68	58.83	109	326	P	H
		7311	52.58	-1.42	54	64.55	36.18	10.68	58.83	109	326	A	H
		4874	48.93	-25.07	74	67.63	31.36	8.49	58.55	100	0	P	V
		7311	55.76	-18.24	74	67.73	36.18	10.68	58.83	106	303	P	V
		7311	52.17	-1.83	54	64.14	36.18	10.68	58.83	106	303	A	V
802.11b CH 11 2462MHz		4924	51.33	-22.67	74	69.76	31.46	8.64	58.53	392	156	P	H
		4924	49.28	-4.72	54	67.71	31.46	8.64	58.53	392	156	A	H
		7386	55.04	-18.96	74	66.72	36.37	10.67	58.72	321	322	P	H
		7386	51.41	-2.59	54	63.09	36.37	10.67	58.72	321	322	A	H
		4924	47.58	-26.42	74	66.01	31.46	8.64	58.53	100	0	P	V
			7386	55.74	-18.26	74	67.42	36.37	10.67	58.72	100	303	P
		7386	51.25	-2.75	54	62.93	36.37	10.67	58.72	100	303	A	V
802.11b CH 12 2467MHz		4934	46.66	-27.34	74	65.02	31.46	8.71	58.53	100	0	P	H
		7401	48.22	-25.78	74	59.84	36.41	10.67	58.7	100	0	P	H
		4934	44.14	-29.86	74	62.5	31.46	8.71	58.53	100	0	P	V
		7401	47.61	-26.39	74	59.23	36.41	10.67	58.7	100	0	P	V
802.11b CH 13 2472MHz		4944	41.97	-32.03	74	60.28	31.5	8.71	58.52	100	0	P	H
		7416	46.31	-27.69	74	57.9	36.41	10.7	58.7	100	0	P	H
		4944	42.63	-31.37	74	60.94	31.5	8.71	58.52	100	0	P	V
		7416	45.2	-28.8	74	56.79	36.41	10.7	58.7	100	0	P	V
Remark	1. No other spurious found. 2. All results are PASS against Peak and Average limit line.												