



FCC RADIO TEST REPORT

FCC ID : 2AP4W-VLITE
Equipment : mPERS
Brand Name : Belle
Model Name : Belle X VZW
Marketing Name : Belle X
Applicant : Freeus, LLC
1069 Stewart Dr, Suites 3-6 Ogden,
Utah 84404, United States
Manufacturer : WiBASE Industrial Solutions Inc.
Bldg. G, 17F, No. 3-1, Yuan Qu St., Nan
Gang Dist., Taipei City, 115, Taiwan.
Standard : FCC Part 15 Subpart C §15.247

The product was received on Jun. 18, 2021 and testing was started from Aug. 05, 2021 and completed on Sep. 14, 2021. We, Sporton International Inc. EMC & Wireless Communications Laboratory, would like to declare that the tested sample has been evaluated in accordance with the test procedures and has been in compliance with the applicable technical standards.

The test results in this report apply exclusively to the tested model / sample. Without written approval of Sporton International Inc. EMC & Wireless Communications Laboratory, the test report shall not be reproduced except in full.

Louis Wu

Approved by: Louis Wu

Sporton International Inc. EMC & Wireless Communications Laboratory

No. 52, Huaya 1st Rd., Guishan Dist., Taoyuan City 333, Taiwan (R.O.C.)



Table of Contents

History of this test report.....	3
Summary of Test Result.....	4
1 General Description.....	5
1.1 Product Feature of Equipment Under Test.....	5
1.2 Modification of EUT	5
1.3 Testing Location	5
1.4 Applicable Standards.....	5
2 Test Configuration of Equipment Under Test	6
2.1 Carrier Frequency Channel	6
2.2 Test Mode.....	7
2.3 Connection Diagram of Test System.....	8
2.4 Support Unit used in test configuration and system	9
2.5 EUT Operation Test Setup	9
2.6 Measurement Results Explanation Example.....	9
3 Test Result.....	10
3.1 6dB and 99% Bandwidth Measurement	10
3.2 Output Power Measurement.....	13
3.3 Power Spectral Density Measurement	14
3.4 Conducted Band Edges and Spurious Emission Measurement	17
3.5 Radiated Band Edges and Spurious Emission Measurement	21
3.6 AC Conducted Emission Measurement.....	25
3.7 Antenna Requirements	27
4 List of Measuring Equipment	28
5 Uncertainty of Evaluation.....	30
Appendix A. Conducted Test Results	
Appendix B. AC Conducted Emission Test Result	
Appendix C. Radiated Spurious Emission	
Appendix D. Radiated Spurious Emission Plots	
Appendix E. Duty Cycle Plots	
Appendix F. Setup Photographs	



History of this test report

Report No.	Version	Description	Issued Date
FR982310-04	01	Initial issue of report	Aug. 27, 2021
FR982310-04	02	1. Revise applicant address 2. Revise Test Mode 3. Revise Connection Diagram of Test System 4. Revise Support Unit used in test configuration and system 5. Revise typo in section 3.3.3	Sep. 06, 2021
FR982310-04	03	Revise conducted test data	Sep. 14, 2021



Summary of Test Result

Report Clause	Ref Std. Clause	Test Items	Result (PASS/FAIL)	Remark
3.1	15.247(a)(2)	6dB Bandwidth	Pass	-
3.1	2.1049	99% Occupied Bandwidth	Reporting only	-
3.2	15.247(b)(3)	Output Power	Pass	-
3.3	15.247(e)	Power Spectral Density	Pass	-
3.4	15.247(d)	Conducted Band Edges and Spurious Emission	Pass	-
3.5	15.247(d)	Radiated Band Edges and Spurious Emission	Pass	Under limit 6.23 dB at 245.190 MHz
3.6	15.207	AC Conducted Emission	Pass	Under limit 5.09 dB at 0.161 MHz
3.7	15.203 & 15.247(b)	Antenna Requirement	Pass	-

Declaration of Conformity:

The test results with all measurement uncertainty excluded are presented in accordance with the regulation limits or requirements declared by manufacturers.

Comments and Explanations:

The declared of product specification for EUT presented in the report are provided by the manufacturer, and the manufacturer takes all the responsibilities for the accuracy of product specification.

Reviewed by: Yun Huang

Report Producer: Amy Chen



1 General Description

1.1 Product Feature of Equipment Under Test

LTE, Bluetooth - LE, Wi-Fi 2.4GHz 802.11b/g/n and GNSS.

Product Specification subjective to this standard		
Antenna Type	WWAN	
	<Main>: LDS Antenna <Div>: LDS Antenna WLAN: LDS Antenna Bluetooth - LE: LDS Antenna GPS / Glonass: LDS Antenna	
Antenna information		
2400 MHz ~ 2483.5 MHz	Peak Gain (dBi)	-4.6

Remark: The above EUT's information was declared by manufacturer. Please refer to Comments and Explanations in report summary.

1.2 Modification of EUT

No modifications are made to the EUT during all test items.

1.3 Testing Location

Test Site	Sporton International Inc. EMC & Wireless Communications Laboratory
Test Site Location	No.52, Huaya 1st Rd., Guishan Dist., Taoyuan City 333, Taiwan (R.O.C.) TEL: +886-3-327-3456 FAX: +886-3-328-4978
Test Site No.	Sporton Site No.
	TH02-HY, CO05-HY, 03CH07-HY

Note: The test site complies with ANSI C63.4 2014 requirement.

FCC designation No.: TW1190

1.4 Applicable Standards

According to the specifications of the manufacturer, the EUT must comply with the requirements of the following standards:

- ♦ FCC Part 15 Subpart C §15.247
- ♦ FCC KDB Publication No. 558074 D01 DTS Meas. Guidance v05r02
- ♦ FCC KDB 414788 D01 Radiated Test Site v01r01
- ♦ ANSI C63.10-2013

Remark:

1. All test items were verified and recorded according to the standards and without any deviation during the test.
2. The TAF code is not including all the FCC KDB listed without accreditation.



2 Test Configuration of Equipment Under Test

2.1 Carrier Frequency Channel

Frequency Band	Channel	Freq. (MHz)	Channel	Freq. (MHz)
2400-2483.5 MHz	0	2402	21	2444
	1	2404	22	2446
	2	2406	23	2448
	3	2408	24	2450
	4	2410	25	2452
	5	2412	26	2454
	6	2414	27	2456
	7	2416	28	2458
	8	2418	29	2460
	9	2420	30	2462
	10	2422	31	2464
	11	2424	32	2466
	12	2426	33	2468
	13	2428	34	2470
	14	2430	35	2472
	15	2432	36	2474
	16	2434	37	2476
	17	2436	38	2478
	18	2438	39	2480
	19	2440	-	-
20	2442	-	-	



2.2 Test Mode

- a. The EUT has been associated with peripherals and configuration operated in a manner tended to maximize its emission characteristics in a typical application. Frequency range investigated: conduction emission (150 kHz to 30 MHz), radiation emission (9 kHz to the 10th harmonic of the highest fundamental frequency or to 40 GHz, whichever is lower).
- b. AC power line Conducted Emission was tested under maximum output power.

The following summary table is showing all test modes to demonstrate in compliance with the standard.

Summary table of Test Cases	
Test Item	Data Rate / Modulation
Conducted Test Cases	Bluetooth – LE / GFSK
	Mode 1: Bluetooth Tx CH00_2402 MHz_1Mbps
	Mode 2: Bluetooth Tx CH19_2440 MHz_1Mbps
	Mode 3: Bluetooth Tx CH39_2480 MHz_1Mbps
Radiated Test Cases	Mode 1: Bluetooth Tx CH00_2402 MHz_1Mbps
	Mode 2: Bluetooth Tx CH19_2440 MHz_1Mbps
	Mode 3: Bluetooth Tx CH39_2480 MHz_1Mbps
AC Conducted Emission	Mode 1: Bluetooth - LE Tx + USB Charging Cradle + Notebook

2.3 Connection Diagram of Test System

<AC Conducted Emission Mode>

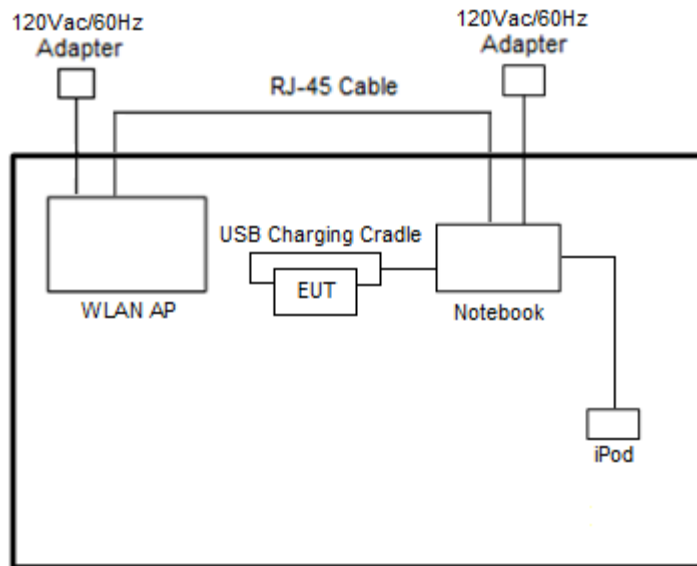

<Bluetooth – LE Tx Mode>

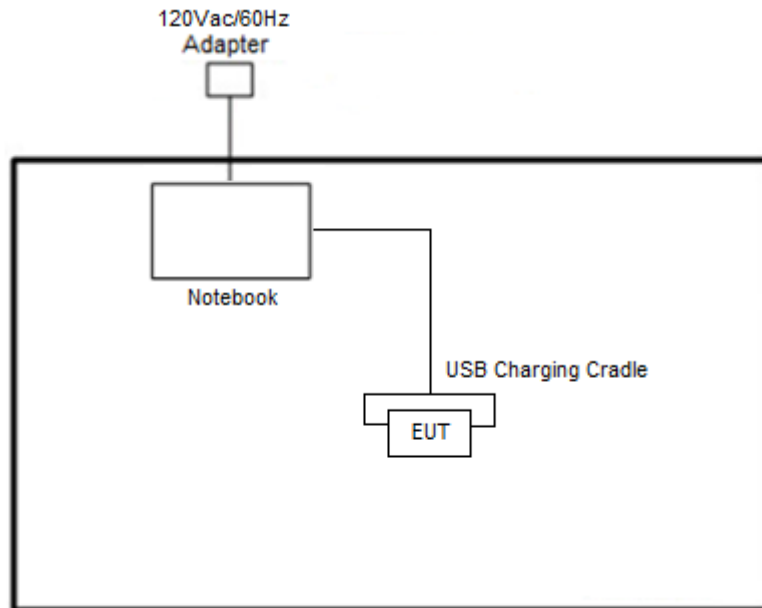



2.4 Support Unit used in test configuration and system

Item	Equipment	Brand Name	Model Name	FCC ID	Data Cable	Power Cord
1.	WLAN AP	ASUS	RT-AC66U	MSQ-RTAC66U	N/A	Unshielded, 1.8 m
2.	iPod	Apple	A1285	FCC DoC	Shielded, 1.0 m	N/A
3.	Notebook	Dell	Latitude 3400	FCC DoC	N/A	AC I/P: Unshielded, 1.2 m DC O/P: Shielded, 1.8 m
4.	Notebook	DELL	E3340	FCC DoC	N/A	AC I/P: Unshielded, 1.2 m DC O/P: Shielded, 1.8 m
5.	USB Charging Cradle	Phihong	WALLABY CHARGING CRADLE USB 4pin	N/A	N/A	N/A

2.5 EUT Operation Test Setup

The RF test items, utility “Qualcomm® Radio Control Toolkit v4.0” was installed in Notebook which was programmed in order to make the EUT get into the engineering modes to provide channel selection, power level, data rate and the application type and for continuous transmitting signals.

2.6 Measurement Results Explanation Example

For all conducted test items:

The offset level is set in the spectrum analyzer to compensate the RF cable loss and attenuator factor between EUT conducted output port and spectrum analyzer. With the offset compensation, the spectrum analyzer reading level is exactly the EUT RF output level.

Example :

The spectrum analyzer offset is derived from RF cable loss and attenuator factor.

Offset = RF cable loss + attenuator factor.

Following shows an offset computation example with cable loss 4.2 dB and 10 dB attenuator.

$$\begin{aligned} \text{Offset(dB)} &= \text{RF cable loss(dB)} + \text{attenuator factor(dB)}. \\ &= 4.2 + 10 = 14.2 \text{ (dB)} \end{aligned}$$

3 Test Result

3.1 6dB and 99% Bandwidth Measurement

3.1.1 Limit of 6dB and 99% Bandwidth

The minimum 6 dB bandwidth shall be at least 500 kHz.

3.1.2 Measuring Instruments

See list of measuring equipment of this test report.

3.1.3 Test Procedures

1. The testing follows the ANSI C63.10 Section 6.9.3 (OBW) and 11.8.1 (6dB BW).
2. The RF output of EUT was connected to the spectrum analyzer by RF cable and attenuator. The path loss was compensated to the results for each measurement.
3. Set the maximum power setting and enable the EUT to transmit continuously.
4. Make the measurement with the spectrum analyzer's resolution bandwidth (RBW) = 100 kHz. Set the Video bandwidth (VBW) = 300 kHz. In order to make an accurate measurement. The 6dB bandwidth must be greater than 500 kHz.
5. For 99% Bandwidth Measurement, the spectrum analyzer's resolution bandwidth (RBW) is set 1-5% of the emission bandwidth and set the Video bandwidth (VBW) $\geq 3 * RBW$.
6. Measure and record the results in the test report.

3.1.4 Test Setup





3.1.5 Test Result of 6dB Bandwidth

Please refer to Appendix A.

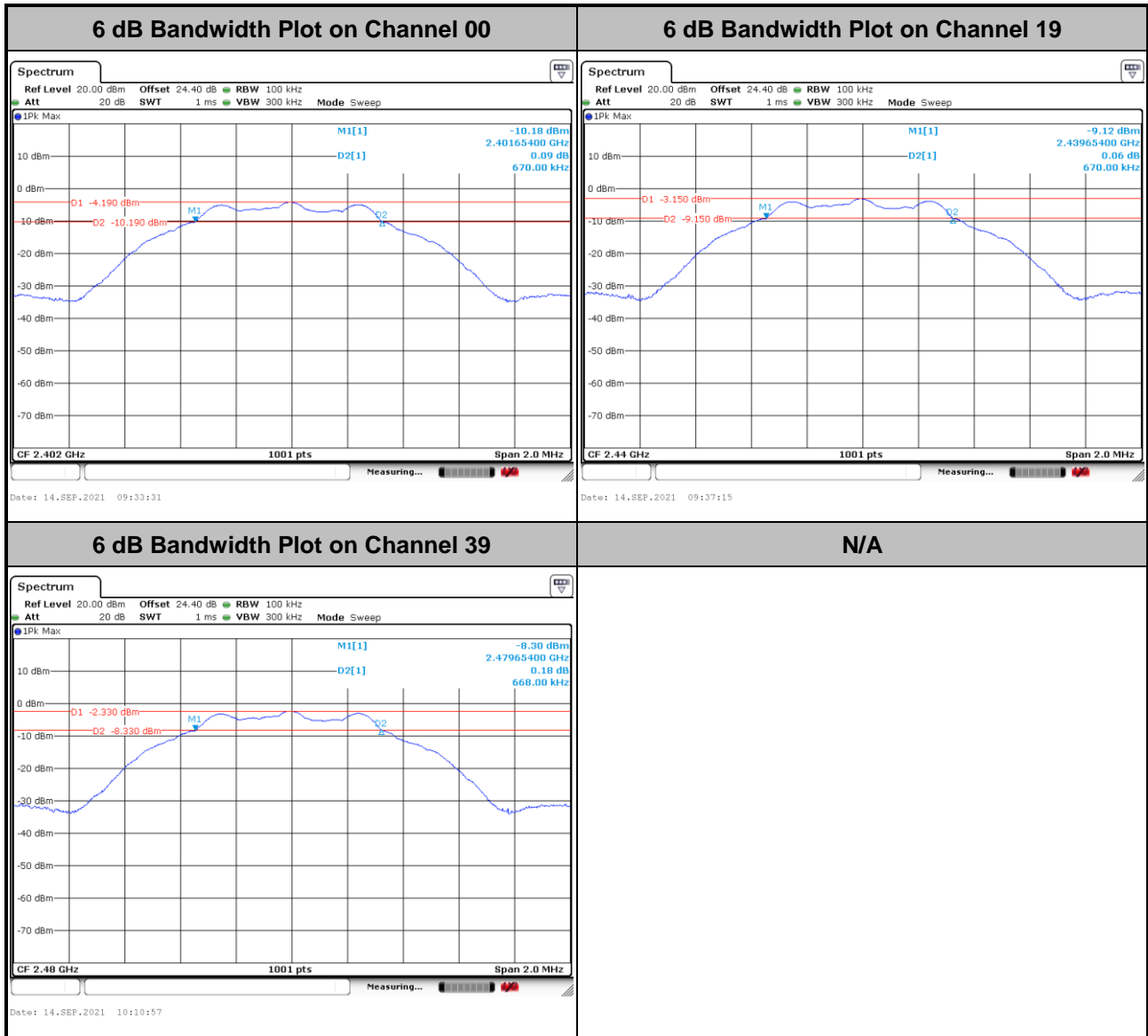



3.1.6 Test Result of 99% Occupied Bandwidth

Please refer to Appendix A.

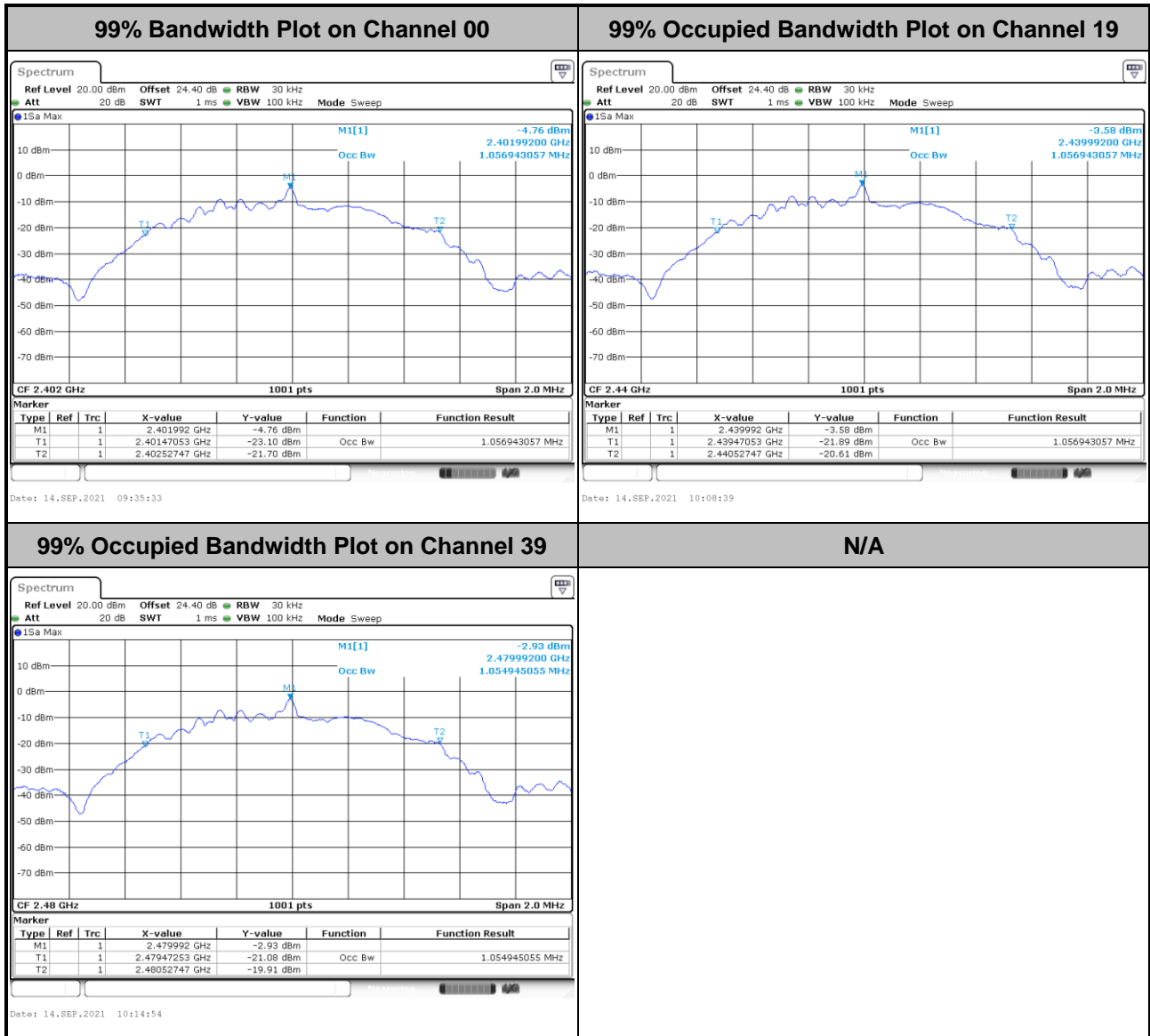

Note: The occupied channel bandwidth is maintained within the band of operation for all of the modulations.

3.2 Output Power Measurement

3.2.1 Limit of Output Power

For systems using digital modulation in the 2400-2483.5 MHz, the limit for output power is 30 dBm. If transmitting antenna of directional gain greater than 6 dBi is used, the peak output power from the intentional radiator shall be reduced below the above stated value by the amount in dB that the directional gain of the antenna exceeds 6 dBi. In case of point-to-point operation, the limit has to be reduced by 1 dB for every 3 dB that the directional gain of the antenna exceeds 6 dBi.

3.2.2 Measuring Instruments

See list of measuring equipment of this test report.

3.2.3 Test Procedures

1. For Average Power, the testing follows ANSI C63.10 Section 11.9.2.3.2 Method AVGPM-G
2. The RF output of EUT was connected to the power meter by RF cable and attenuator.
3. The path loss was compensated to the results for each measurement.
4. Set the maximum power setting and enable the EUT to transmit continuously.
5. Measure the conducted output power and record the results in the test report.

3.2.4 Test Setup

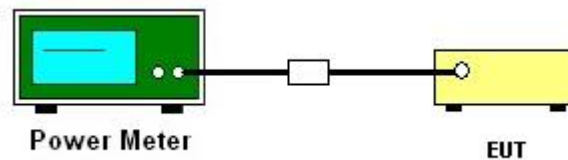

3.2.5 Test Result of Average Output Power

Please refer to Appendix A.

3.3 Power Spectral Density Measurement

3.3.1 Limit of Power Spectral Density

The peak power spectral density shall not be greater than 8 dBm in any 3 kHz band at any time interval of continuous transmission.

3.3.2 Measuring Instruments

See list of measuring equipment of this test report.

3.3.3 Test Procedures

1. The testing follows the ANSI C63.10 Section 11.10.2 Method PKPSD.
2. The RF output of EUT was connected to the spectrum analyzer by RF cable and attenuator. The path loss was compensated to the results for each measurement.
3. Set the maximum power setting and enable the EUT to transmit continuously.
4. Make the measurement with the spectrum analyzer's resolution bandwidth (RBW) = 3 kHz. Video bandwidth VBW = 10 kHz. In order to make an accurate measurement, set the span to 1.5 times DTS Channel Bandwidth. (6dB BW)
5. Detector = peak, Sweep time = auto couple, Trace mode = max hold, Allow trace to fully stabilize. Use the peak marker function to determine the maximum power level.
6. Measure and record the results in the test report.
7. The Measured power density (dBm)/ 100 kHz is a reference level and is used as 30 dBc down limit line for Conducted Band Edges and Conducted Spurious Emission.

3.3.4 Test Setup

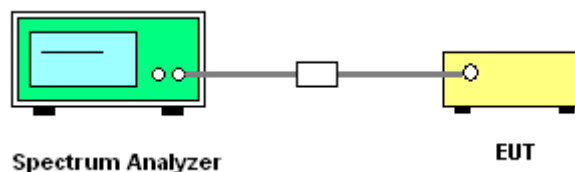

3.3.5 Test Result of Power Spectral Density

Please refer to Appendix A.



3.3.6 Test Result of Power Spectral Density Plots (100kHz)

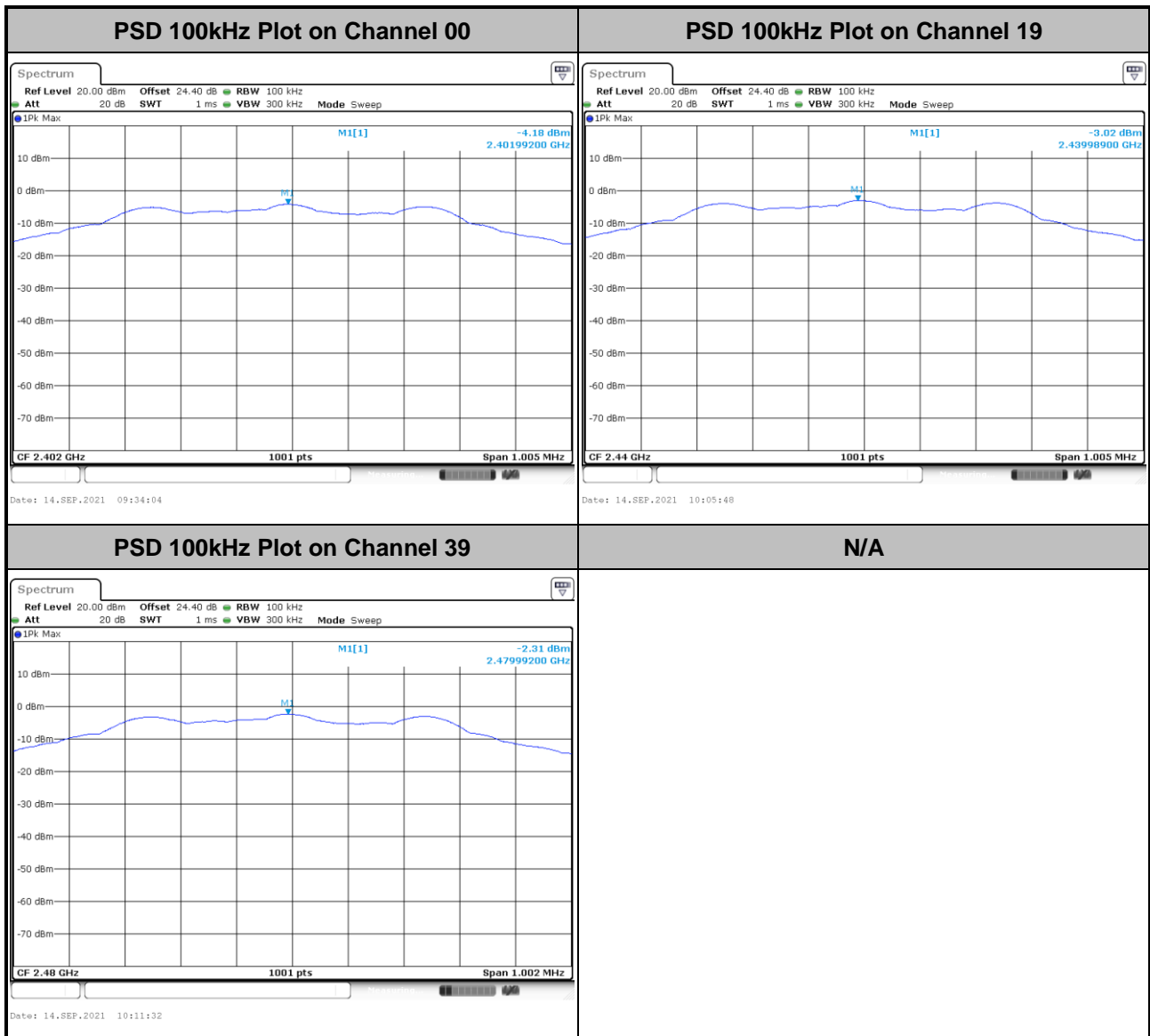



3.3.7 Test Result of Power Spectral Density Plots (3kHz)

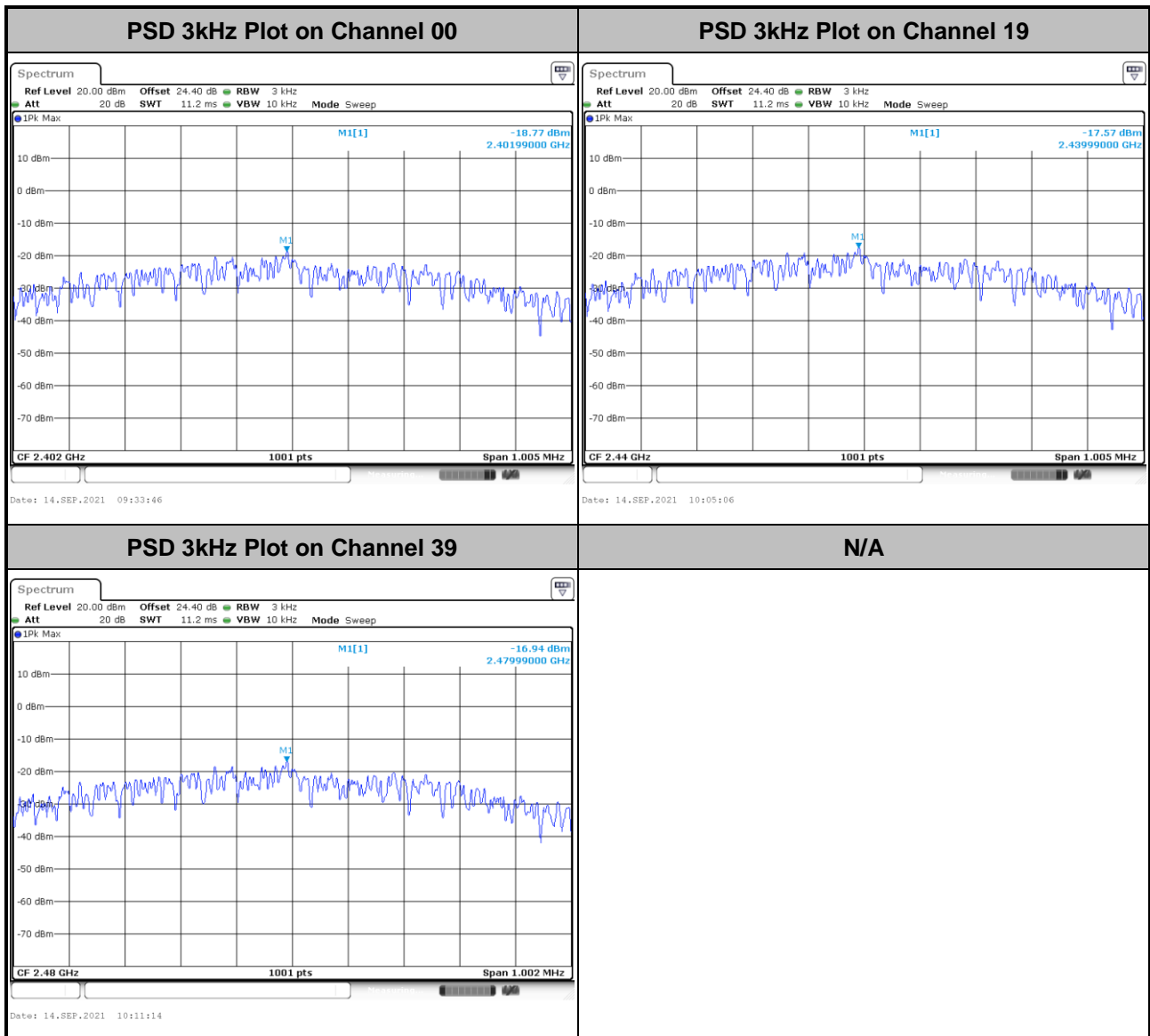

3.4 Conducted Band Edges and Spurious Emission Measurement

3.4.1 Limit of Conducted Band Edges and Spurious Emission

All harmonics/spurious must be at least 20 dB down from the highest emission level within the authorized band.

3.4.2 Measuring Instruments

See list of measuring equipment of this test report.

3.4.3 Test Procedure

1. The testing follows the ANSI C63.10 Section 11.11.3 Emission level measurement.
2. The RF output of EUT was connected to the spectrum analyzer by RF cable and attenuator. The path loss was compensated to the results for each measurement.
3. Set the maximum power setting and enable the EUT to transmit continuously.
4. Set RBW = 100 kHz, VBW = 300 kHz, Peak Detector. Unwanted Emissions measured in any 100 kHz bandwidth outside of the authorized frequency band shall be attenuated by at least 20 dB relative to the maximum in-band peak PSD level in 100 kHz when maximum peak conducted output power procedure is used. If the transmitter complies with the conducted power limits based on the use of RMS averaging over a time interval, the attenuation required under this paragraph shall be 30 dB instead of 20 dB.
5. Measure and record the results in the test report.
6. The RF fundamental frequency should be excluded against the limit line in the operating frequency band.

3.4.4 Test Setup

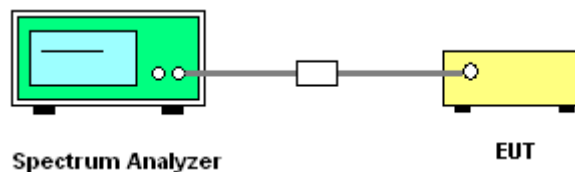



3.4.5 Test Result of Conducted Band Edges Plots

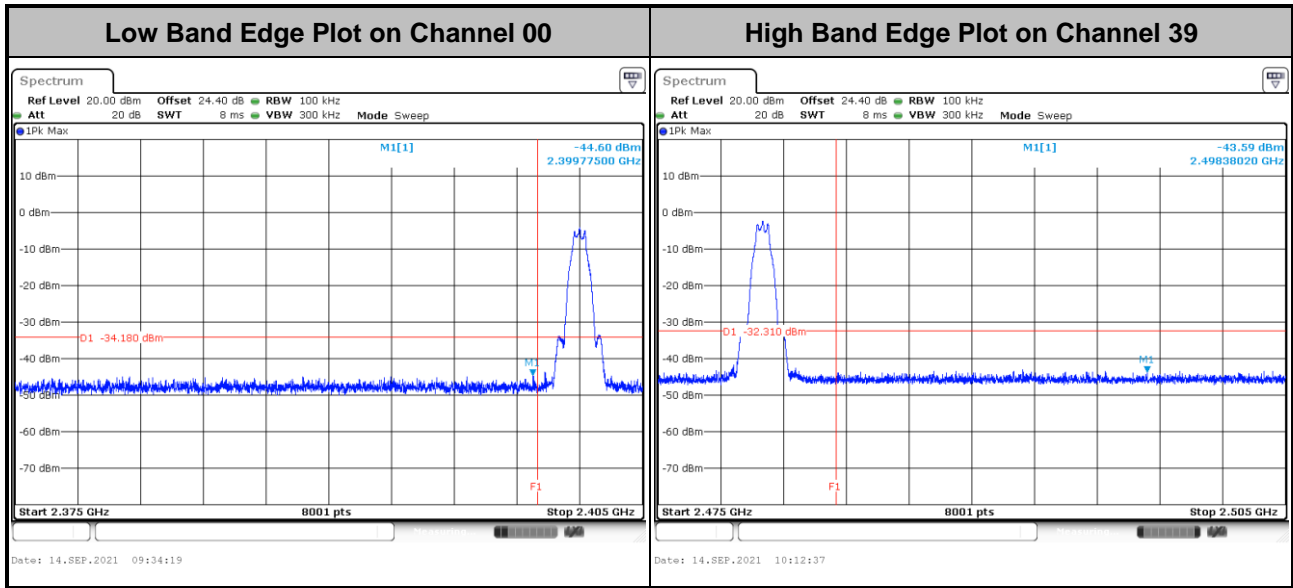



3.4.6 Test Result of Conducted Spurious Emission Plots

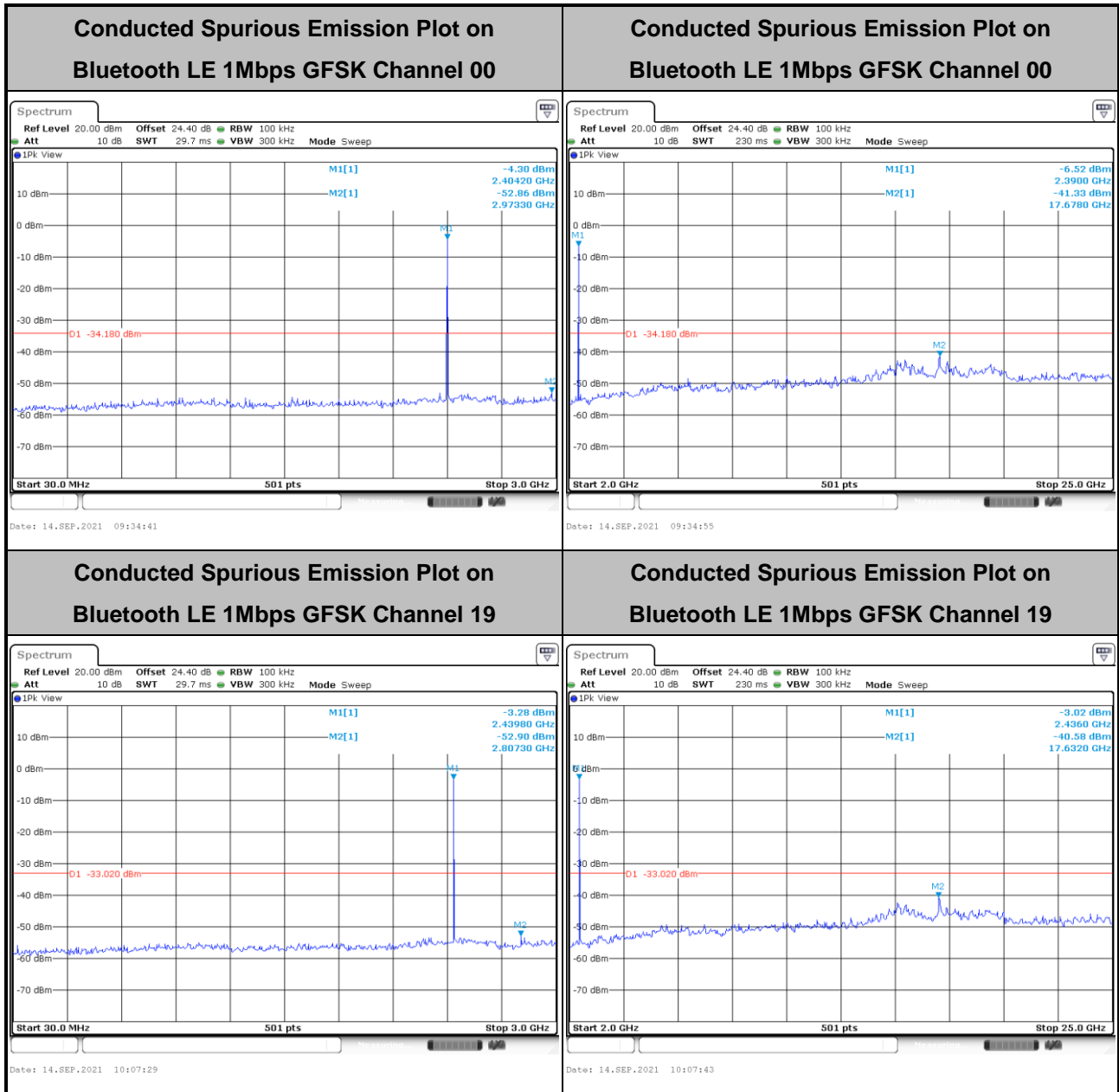

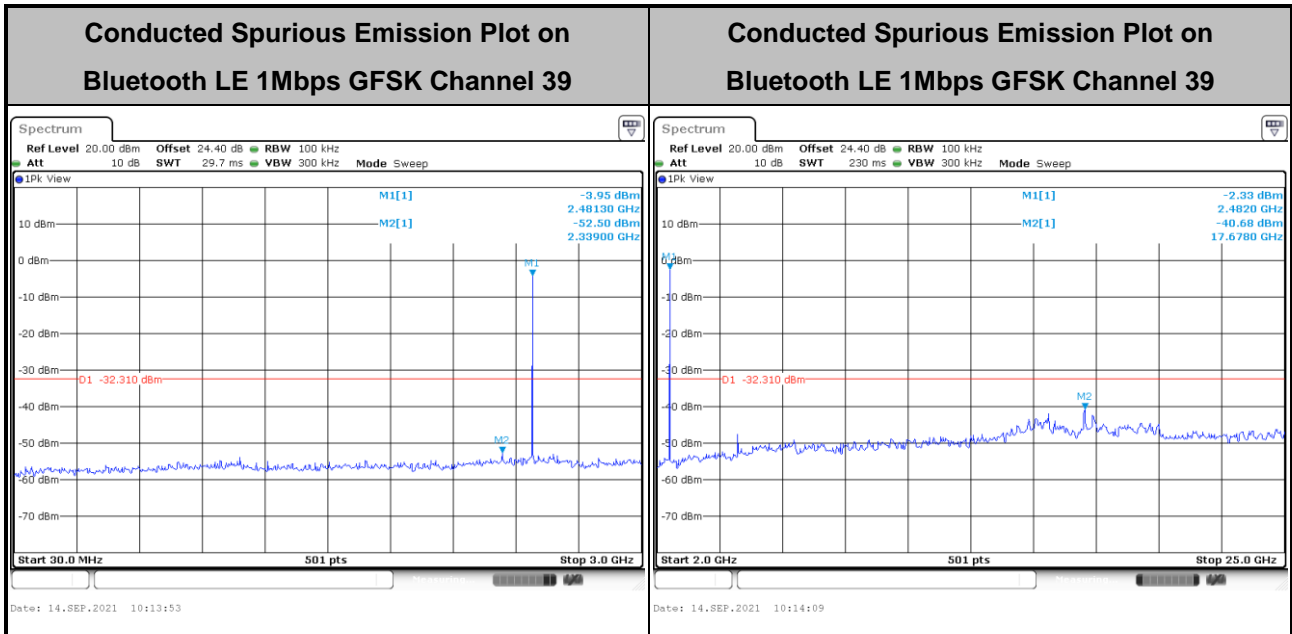



3.5 Radiated Band Edges and Spurious Emission Measurement

3.5.1 Limit of Radiated Band Edges and Spurious Emission

In any 100 kHz bandwidth outside the intentional radiator frequency band, all harmonics/spurious must be at least 20 dB below the highest emission level within the authorized band. If the output power of this device was measured by spectrum analyzer, the attenuation under this paragraph shall be 30 dB instead of 20 dB. In addition, radiated emissions which fall in the restricted bands must also comply with the limits as below.

Frequency (MHz)	Field Strength (microvolts/meter)	Measurement Distance (meters)
0.009 – 0.490	2400/F(kHz)	300
0.490 – 1.705	24000/F(kHz)	30
1.705 – 30.0	30	30
30 – 88	100	3
88 – 216	150	3
216 - 960	200	3
Above 960	500	3

3.5.2 Measuring Instruments

See list of measuring equipment of this test report.



3.5.3 Test Procedures

1. The testing follows the ANSI C63.10 Section 11.12.1 Radiated emission measurements.
2. The EUT was arranged to its worst case and then tune the antenna tower (from 1 m to 4 m) and turntable (from 0 degree to 360 degrees) to find the maximum reading. A pre-amp and a high pass filter are used for the test in order to get better signal level.
3. The EUT was placed on a turntable with 0.8 meter for frequency below 1 GHz and 1.5 meter for frequency above 1 GHz respectively above ground.
4. The EUT was set 3 meters from the interference receiving antenna, which was mounted on the top of a variable height antenna tower.
5. Corrected Reading: Antenna Factor + Cable Loss + Read Level - Preamp Factor = Level
6. For testing below 1 GHz, if the emission level of the EUT in peak mode was 3 dB lower than the limit specified, then peak values of EUT will be reported, otherwise, the emissions will be repeated one by one using the CISPR quasi-peak method and be reported.
7. For testing above 1 GHz, the emission level of the EUT in peak mode was 20 dB lower than average limit (that means the emission level in average mode also complies with the limit in average mode), then peak values of EUT will be reported, otherwise, the emissions will be measured in average mode again and be reported.
8. Use the following spectrum analyzer settings:
 - (1) Span shall wide enough to fully capture the emission being measured;
 - (2) Set RBW = 100 kHz for $f < 1$ GHz; VBW \geq RBW; Sweep = auto; Detector function = peak; Trace = max hold;
 - (3) Set RBW = 1 MHz, VBW = 3 MHz for $f \geq 1$ GHz for peak measurement.
For average measurement:
 - VBW = 10 Hz, when duty cycle is no less than 98 percent.
 - VBW $\geq 1/T$, when duty cycle is less than 98 percent where T is the minimum transmission duration over which the transmitter is on and is transmitting at its maximum power control level for the tested mode of operation.

3.5.4 Test Setup

For radiated test below 30MHz

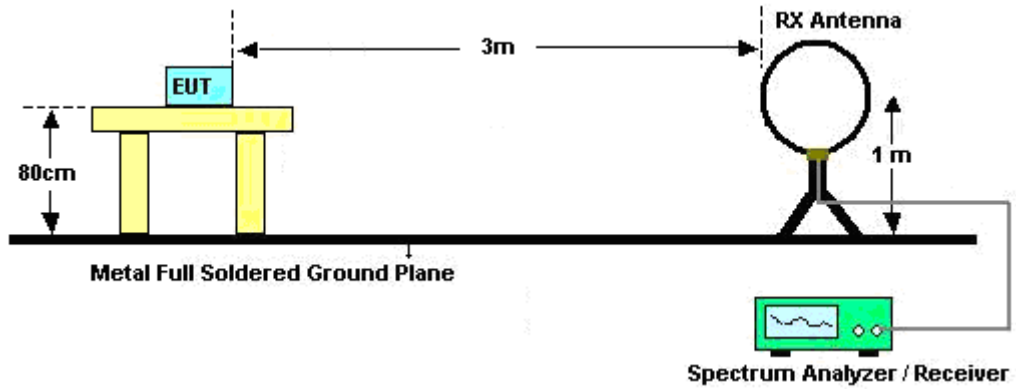

For radiated test from 30MHz to 1GHz

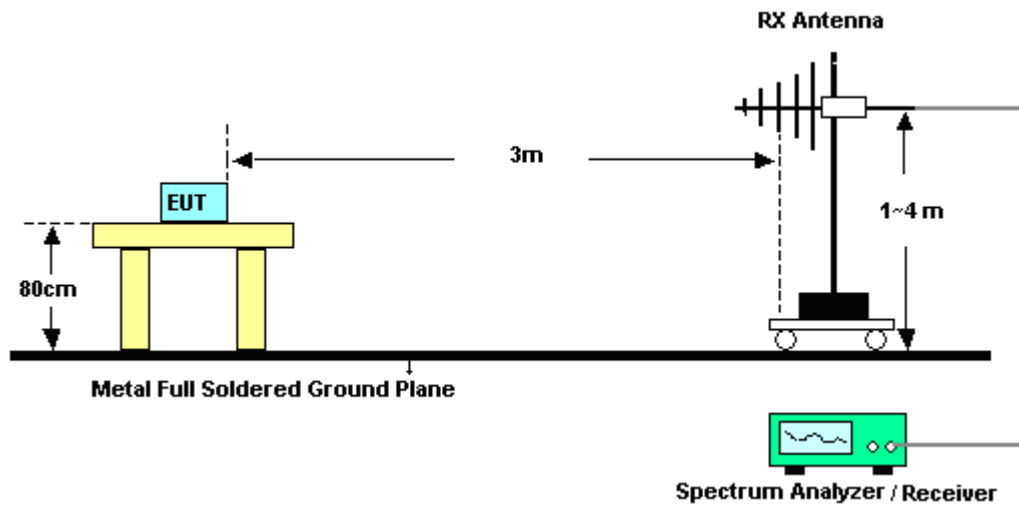

For radiated test above 1GHz

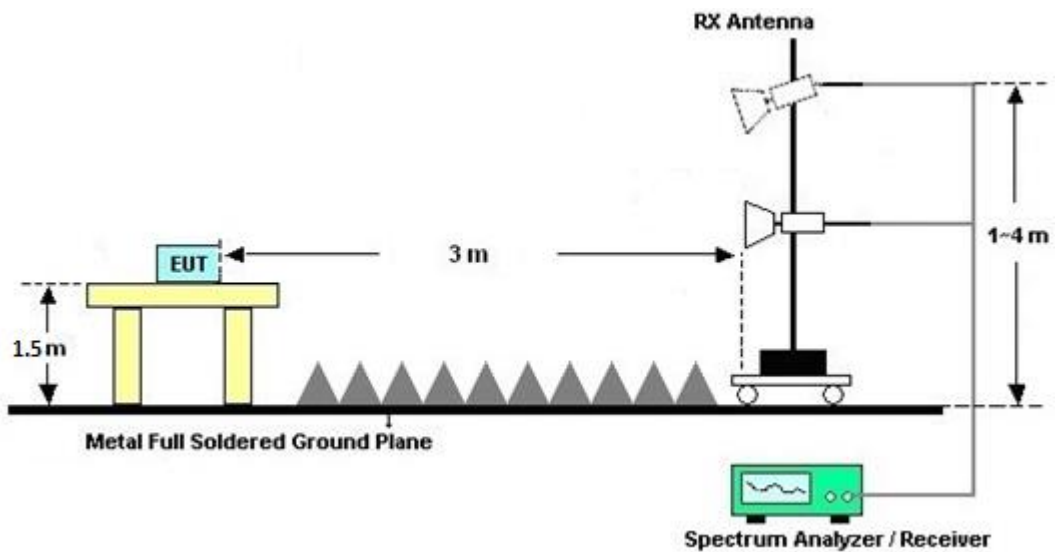



3.5.5 Test Results of Radiated Spurious Emissions (9 kHz ~ 30 MHz)

The low frequency, which started from 9 kHz to 30MHz, was pre-scanned and the result which was 20dB lower than the limit line was not reported.

There is adequate comparison measurement of both open-field test site and alternative test site - semi-Anechoic chamber according to 414788 D01 Radiated Test Site v01r01, and the result came out very similar.

3.5.6 Test Result of Radiated Spurious at Band Edges

Please refer to Appendix C and D.

3.5.7 Duty Cycle

Please refer to Appendix E.

3.5.8 Test Result of Radiated Spurious Emission (30 MHz ~ 10th Harmonic)

Please refer to Appendix C and D.



3.6 AC Conducted Emission Measurement

3.6.1 Limit of AC Conducted Emission

For equipment that is designed to be connected to the public utility (AC) power line, the radio frequency voltage that is conducted back onto the AC power line on any frequency or frequencies within the band 150 kHz to 30 MHz shall not exceed the limits in the following table.

Frequency of emission (MHz)	Conducted limit (dB μ V)	
	Quasi-peak	Average
0.15-0.5	66 to 56*	56 to 46*
0.5-5	56	46
5-30	60	50

*Decreases with the logarithm of the frequency.

3.6.2 Measuring Instruments

See list of measuring equipment of this test report.

3.6.3 Test Procedures

1. The EUT was placed 0.4 meter from the conducting wall of the shielding room was kept at least 80 centimeters from any other grounded conducting surface.
2. Connect EUT to the power mains through a line impedance stabilization network (LISN).
3. All the support units are connecting to the other LISN.
4. The LISN provides 50 ohm coupling impedance for the measuring instrument.
5. The FCC states that a 50 ohm, 50 microhenry LISN shall be used.
6. Both sides of AC line were checked for maximum conducted interference.
7. The frequency range from 150 kHz to 30 MHz was searched.
8. Set the test-receiver system to Peak Detect Function and specified bandwidth (IF Bandwidth = 9kHz) with Maximum Hold Mode. Then measurement is also conducted by Average Detector and Quasi-Peak Detector Function respectively.

3.6.4 Test Setup

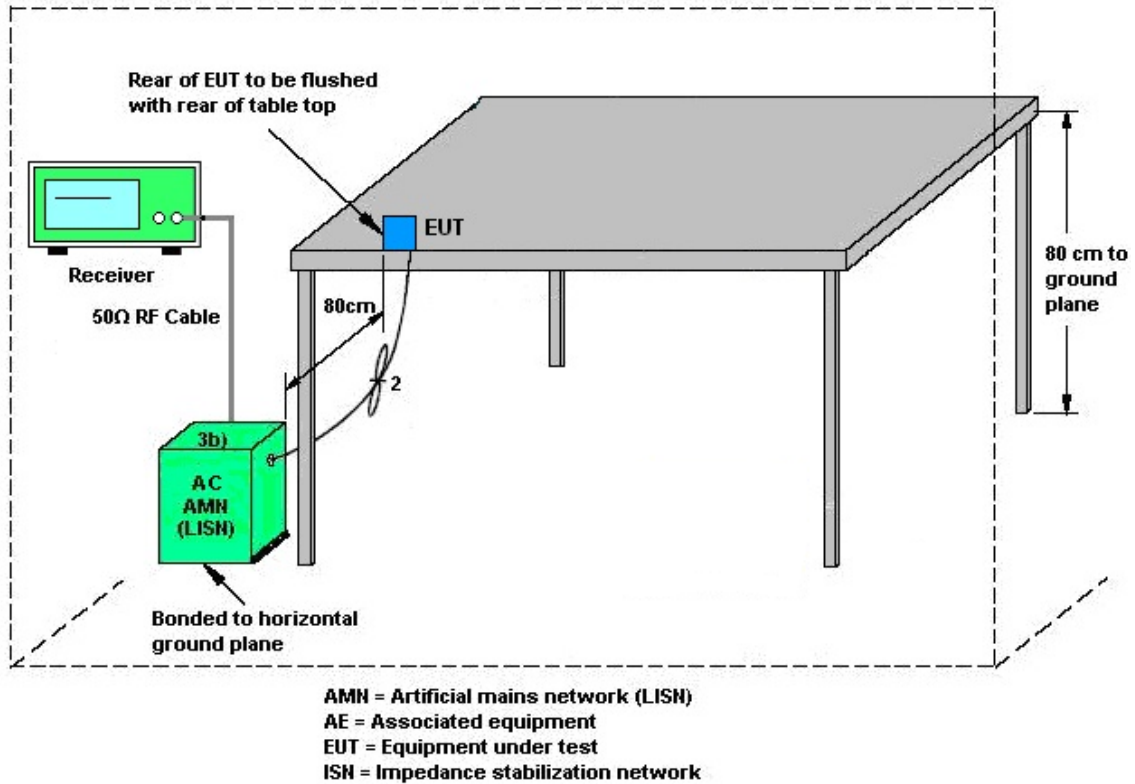

3.6.5 Test Result of AC Conducted Emission

Please refer to Appendix B.



3.7 Antenna Requirements

3.7.1 Standard Applicable

If directional gain of transmitting antennas is greater than 6 dBi, the power shall be reduced by the same level in dB comparing to gain minus 6 dBi. The use of a permanently attached antenna or of an antenna that uses a unique coupling to the intentional radiator shall be considered sufficient to comply with the rule.

3.7.2 Antenna Anti-Replacement Construction

An embedded-in antenna design is used.

3.7.3 Antenna Gain

The antenna peak gain of EUT is less than 6 dBi. Therefore, it is not necessary to reduce maximum peak output power limit.



4 List of Measuring Equipment

Instrument	Brand Name	Model No.	Serial No.	Characteristics	Calibration Date	Test Date	Due Date	Remark
Bilog Antenna	TESEQ	CBL 6111D & 00800N1D01N-06	35419 & 03	30MHz~1GHz	Apr. 28, 2021	Aug. 12, 2021~ Aug. 13, 2021	Apr. 27, 2022	Radiation (03CH07-HY)
Double Ridge Horn Antenna	ESCO	3117	00075962	1GHz ~ 18GHz	Dec. 01, 2020	Aug. 12, 2021~ Aug. 13, 2021	Nov. 30, 2021	Radiation (03CH07-HY)
Loop Antenna	Rohde & Schwarz	HFH2-Z2	100315	9 kHz~30 MHz	Jan. 04, 2021	Aug. 12, 2021~ Aug. 13, 2021	Jan. 03, 2022	Radiation (03CH07-HY)
Preamplifier	MITEQ	AMF-7D-00101800-30-10P	1590075	1GHz~18GHz	Apr. 22, 2021	Aug. 12, 2021~ Aug. 13, 2021	Apr. 21, 2022	Radiation (03CH07-HY)
Preamplifier	COM-POWER	PA-103A	161241	10MHz~1GHz	May 18, 2021	Aug. 12, 2021~ Aug. 13, 2021	May 17, 2022	Radiation (03CH07-HY)
Preamplifier	Agilent	8449B	3008A02362	1GHz~26.5GHz	Oct. 31, 2020	Aug. 12, 2021~ Aug. 13, 2021	Oct. 30, 2021	Radiation (03CH07-HY)
Preamplifier	EMEC	EM18G40G	0600789	18-40GHz	Jul. 23, 2021	Aug. 12, 2021~ Aug. 13, 2021	Jul. 22, 2022	Radiation (03CH07-HY)
Spectrum Analyzer	Agilent	N9030A	MY52350276	3Hz~44GHz	Jul. 22, 2021	Aug. 12, 2021~ Aug. 13, 2021	Jul. 21, 2022	Radiation (03CH07-HY)
RF Cable	HUBER + SUHNER	SUCOFLEX 104	MY15682-4	30MHz to 18GHz	Feb. 24, 2021	Aug. 12, 2021~ Aug. 13, 2021	Feb. 23, 2022	Radiation (03CH07-HY)
RF Cable	HUBER + SUHNER	SUCOFLEX 104	MY24971-4	9kHz to 18GHz	Feb. 24, 2021	Aug. 12, 2021~ Aug. 13, 2021	Feb. 23, 2022	Radiation (03CH07-HY)
RF Cable	HUBER + SUHNER	SUCOFLEX 104	MY28655-4	9kHz to 18GHz	Feb. 24, 2021	Aug. 12, 2021~ Aug. 13, 2021	Feb. 23, 2022	Radiation (03CH07-HY)
RF Cable	HUBER + SUHNER	SUCOFLEX 102	MY2858/2,80 1606/2	18GHz~40GHz	Feb. 24, 2021	Aug. 12, 2021~ Aug. 13, 2021	Feb. 23, 2022	Radiation (03CH07-HY)
RF Cable	HUBER + SUHNER	SUCOFLEX 126	532078/126E	30MHz~18GHz	Sep. 18, 2020	Aug. 12, 2021~ Aug. 13, 2021	Sep. 17, 2021	Radiation (03CH07-HY)
Controller	EMEC	EM1000	N/A	Control Ant Mast	Apr. 28, 2021	Aug. 12, 2021~ Aug. 13, 2021	Apr. 27, 2022	Radiation (03CH07-HY)
Controller	MF	MF-7802	N/A	Control Turn table	N/A	Aug. 12, 2021~ Aug. 13, 2021	N/A	Radiation (03CH07-HY)
Antenna Mast	EMEC	AM-BS-4500E	N/A	Boresight mast 1M~4M	Apr. 28, 2021	Aug. 12, 2021~ Aug. 13, 2021	Apr. 27, 2022	Radiation (03CH07-HY)
Turn Table	ChainTek	Chaintek 3000	N/A	0~360 Degree	N/A	Aug. 12, 2021~ Aug. 13, 2021	N/A	Radiation (03CH07-HY)
Attenuator	HONOVA	5910 SMA-50-005-19-NE	ATT-36	N/A	Oct. 31, 2020	Aug. 12, 2021~ Aug. 13, 2021	Oct. 30, 2021	Radiation (03CH07-HY)
Software	Audix	E3 6.2009-8-24	N/A	N/A	N/A	Aug. 12, 2021~ Aug. 13, 2021	N/A	Radiation (03CH07-HY)
USB Data Logger	TECPEL	TR-32	HE17XB249 5	N/A	Mar. 09, 2021	Aug. 12, 2021~ Aug. 13, 2021	Mar. 08, 2022	Radiation (03CH07-HY)
SHF-EHF Horn Antenna	SCHWARZBECK	BBHA 9170	BBHA91702 51	18GHz~40GHz	Dec. 02, 2020	Aug. 12, 2021~ Aug. 13, 2021	Dec. 01, 2021	Radiation (03CH07-HY)



Instrument	Brand Name	Model No.	Serial No.	Characteristics	Calibration Date	Test Date	Due Date	Remark
Hygrometer	Testo	608-H1	34893241	N/A	Mar. 02, 2021	Aug. 05, 2021~ Sep. 14, 2021	Mar. 01, 2022	Conducted (TH02-HY)
Power Sensor	DARE	RPR3006W	16I00054SN O12	10MHz~6GHz	Dec. 16, 2020	Aug. 05, 2021~ Sep. 14, 2021	Dec. 15, 2021	Conducted (TH02-HY)
Spectrum Analyzer	Rohde & Schwarz	FSP40	100055	9kHz-40GHz	Jan. 21, 2021	Aug. 05, 2021~ Sep. 14, 2021	Jan. 20, 2022	Conducted (TH02-HY)
Switch Box & RF Cable	EM Electronics	EMSW18SE	SW200302	N/A	Mar. 17, 2021	Aug. 05, 2021~ Sep. 14, 2021	Mar. 16, 2022	Conducted (TH02-HY)
AC Power Source	ChainTek	APC-1000W	N/A	N/A	N/A	Aug. 13, 2021	N/A	Conduction (CO05-HY)
EMI Test Receiver	Rohde & Schwarz	ESR3	102388	9kHz~3.6GHz	Nov. 30, 2020	Aug. 13, 2021	Nov. 29, 2021	Conduction (CO05-HY)
Hygrometer	Testo	608-H1	34913912	N/A	Nov. 18, 2020	Aug. 13, 2021	Nov. 17, 2021	Conduction (CO05-HY)
LISN	Rohde & Schwarz	ENV216	100080	9kHz~30MHz	Dec. 01, 2020	Aug. 13, 2021	Nov. 30, 2021	Conduction (CO05-HY)
LISN	Rohde & Schwarz	ENV216	100081	9kHz~30MHz	Nov. 16, 2020	Aug. 13, 2021	Nov. 15, 2021	Conduction (CO05-HY)
Software	Rohde & Schwarz	EMC32 V10.30	N/A	N/A	N/A	Aug. 13, 2021	N/A	Conduction (CO05-HY)
Pulse Limiter	SCHWARZBECK	VTSD 9561-F N	00691	N/A	Jul. 28, 2021	Aug. 13, 2021	Jul. 27, 2022	Conduction (CO05-HY)
LISN Cable	MVE	RG-400	260260	N/A	Dec. 31, 2020	Aug. 13, 2021	Dec. 30, 2021	Conduction (CO05-HY)



5 Uncertainty of Evaluation

Uncertainty of Conducted Emission Measurement (150 kHz ~ 30 MHz)

Measuring Uncertainty for a Level of Confidence of 95% ($U = 2Uc(y)$)	2.3 dB
---	--------

Uncertainty of Radiated Emission Measurement (30 MHz ~ 1000 MHz)

Measuring Uncertainty for a Level of Confidence of 95% ($U = 2Uc(y)$)	4.9 dB
---	--------

Uncertainty of Radiated Emission Measurement (1000 MHz ~ 18000 MHz)

Measuring Uncertainty for a Level of Confidence of 95% ($U = 2Uc(y)$)	6.1 dB
---	--------

Uncertainty of Radiated Emission Measurement (18000 MHz ~ 40000 MHz)

Measuring Uncertainty for a Level of Confidence of 95% ($U = 2Uc(y)$)	4.7 dB
---	--------

Appendix A. Test Result of Conducted Test Items

Test Engineer:	Mina Liu	Temperature:	21~25	°C
Test Date:	2021/08/05~2021/09/14	Relative Humidity:	51~56	%

TEST RESULTS DATA
6dB and 99% Occupied Bandwidth

Mod.	Data Rate	NTX	CH.	Freq. (MHz)	99% Occupied BW (MHz)	6dB BW (MHz)	6dB BW Limit (MHz)	Pass/Fail
BLE	1Mbps	1	0	2402	1.057	0.670	0.50	Pass
BLE	1Mbps	1	19	2440	1.057	0.670	0.50	Pass
BLE	1Mbps	1	39	2480	1.055	0.668	0.50	Pass

TEST RESULTS DATA
Average Power Table

Mod.	Data Rate	NTX	CH.	Freq. (MHz)	Average Conducted Power (dBm)	Conducted Power Limit (dBm)	DG (dBi)	EIRP Power (dBm)	EIRP Power Limit (dBm)	Pass /Fail
BLE	1Mbps	1	0	2402	-3.10	30.00	-4.60	-7.70	36.00	Pass
BLE	1Mbps	1	19	2440	-2.00	30.00	-4.60	-6.60	36.00	Pass
BLE	1Mbps	1	39	2480	-1.50	30.00	-4.60	-6.10	36.00	Pass

TEST RESULTS DATA
Peak Power Density

Mod.	Data Rate	NTX	CH.	Freq. (MHz)	Peak PSD (dBm /100kHz)	Peak PSD (dBm /3kHz)	DG (dBi)	Peak PSD Limit (dBm /3kHz)	Pass/Fail
BLE	1Mbps	1	0	2402	-4.18	-18.77	-4.60	8.00	Pass
BLE	1Mbps	1	19	2440	-3.02	-17.57	-4.60	8.00	Pass
BLE	1Mbps	1	39	2480	-2.31	-16.94	-4.60	8.00	Pass

Note: PSD (dBm/ 100kHz) is a reference level used for Conducted Band Edges and Conducted Spurious Emission 30dBc limit.



Appendix B. AC Conducted Emission Test Results

Test Engineer :	Tom Lee	Temperature :	23~26°C
		Relative Humidity :	40~50%

EUT Information

Report NO : 982310-04
 Test Mode : Mode 1
 Test Voltage : Power From System
 Phase : Line

Full Spectrum

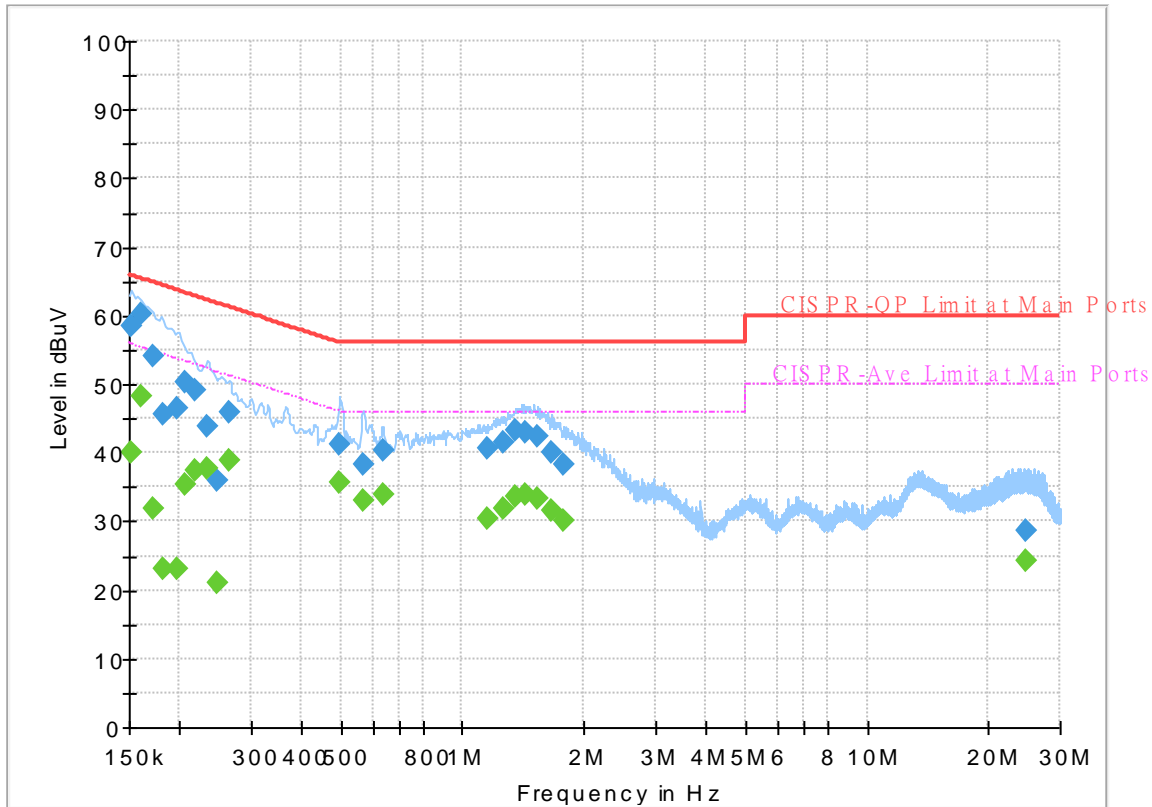

Final_Result

Frequency (MHz)	QuasiPeak (dBuV)	CAverage (dBuV)	Limit (dBuV)	Margin (dB)	Line	Filter	Corr. (dB)
0.152250	---	40.05	55.88	15.83	L1	OFF	19.7
0.152250	58.52	---	65.88	7.36	L1	OFF	19.7
0.161250	---	48.16	55.40	7.24	L1	OFF	19.7
0.161250	60.31	---	65.40	5.09	L1	OFF	19.7
0.172500	---	31.96	54.84	22.88	L1	OFF	19.7
0.172500	54.09	---	64.84	10.75	L1	OFF	19.7
0.181500	---	23.08	54.42	31.34	L1	OFF	19.7
0.181500	45.72	---	64.42	18.70	L1	OFF	19.7
0.197250	---	23.11	53.73	30.62	L1	OFF	19.7
0.197250	46.63	---	63.73	17.10	L1	OFF	19.7
0.206250	---	35.32	53.36	18.04	L1	OFF	19.7
0.206250	50.32	---	63.36	13.04	L1	OFF	19.7
0.217500	---	37.40	52.91	15.51	L1	OFF	19.7
0.217500	49.16	---	62.91	13.75	L1	OFF	19.7
0.233250	---	37.65	52.33	14.68	L1	OFF	19.7
0.233250	43.73	---	62.33	18.60	L1	OFF	19.7
0.246750	---	21.13	51.87	30.74	L1	OFF	19.7
0.246750	36.02	---	61.87	25.85	L1	OFF	19.7
0.264750	---	38.94	51.28	12.34	L1	OFF	19.7
0.264750	45.96	---	61.28	15.32	L1	OFF	19.7
0.496500	---	35.56	46.06	10.50	L1	OFF	19.8

0.496500	41.09	---	56.06	14.97	L1	OFF	19.8
0.566250	---	33.03	46.00	12.97	L1	OFF	19.9
0.566250	38.32	---	56.00	17.68	L1	OFF	19.9
0.636000	---	33.93	46.00	12.07	L1	OFF	20.0
0.636000	40.21	---	56.00	15.79	L1	OFF	20.0
1.155750	---	30.34	46.00	15.66	L1	OFF	20.2
1.155750	40.56	---	56.00	15.44	L1	OFF	20.2
1.263750	---	31.91	46.00	14.09	L1	OFF	20.2
1.263750	41.43	---	56.00	14.57	L1	OFF	20.2
1.353750	---	33.73	46.00	12.27	L1	OFF	20.2
1.353750	43.22	---	56.00	12.78	L1	OFF	20.2
1.434750	---	33.86	46.00	12.14	L1	OFF	20.2
1.434750	43.08	---	56.00	12.92	L1	OFF	20.2
1.529250	---	33.39	46.00	12.61	L1	OFF	20.2
1.529250	42.51	---	56.00	13.49	L1	OFF	20.2
1.655250	---	31.70	46.00	14.30	L1	OFF	20.2
1.655250	40.15	---	56.00	15.85	L1	OFF	20.2
1.783500	---	30.15	46.00	15.85	L1	OFF	20.2
1.783500	38.20	---	56.00	17.80	L1	OFF	20.2
24.783000	---	24.27	50.00	25.73	L1	OFF	20.6
24.783000	28.58	---	60.00	31.42	L1	OFF	20.6

EUT Information

Report NO : 982310-04
 Test Mode : Mode 1
 Test Voltage : Power From System
 Phase : Neutral

Full Spectrum

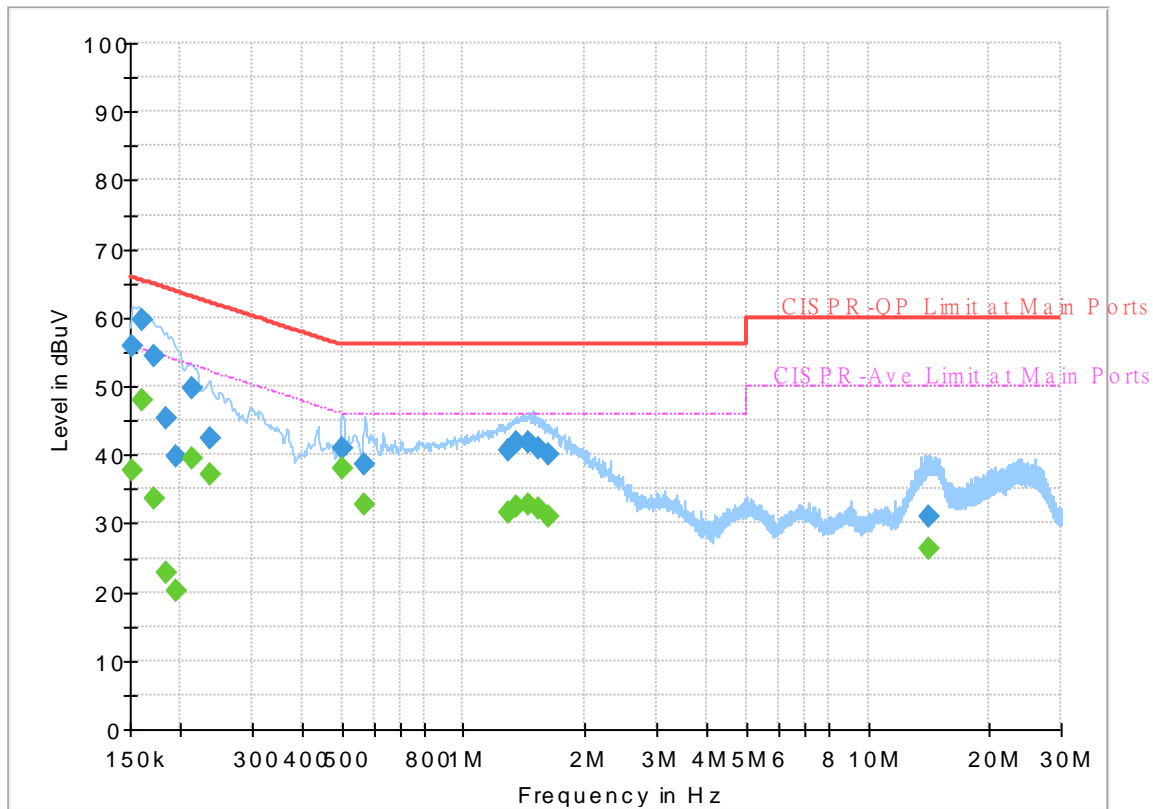

Final_Result

Frequency (MHz)	QuasiPeak (dBuV)	CAverage (dBuV)	Limit (dBuV)	Margin (dB)	Line	Filter	Corr. (dB)
0.152250	---	37.81	55.88	18.07	N	OFF	19.7
0.152250	55.78	---	65.88	10.10	N	OFF	19.7
0.161250	---	47.96	55.40	7.44	N	OFF	19.7
0.161250	59.61	---	65.40	5.79	N	OFF	19.7
0.172500	---	33.73	54.84	21.11	N	OFF	19.7
0.172500	54.39	---	64.84	10.45	N	OFF	19.7
0.183750	---	22.91	54.31	31.40	N	OFF	19.7
0.183750	45.41	---	64.31	18.90	N	OFF	19.7
0.195000	---	20.31	53.82	33.51	N	OFF	19.7
0.195000	39.74	---	63.82	24.08	N	OFF	19.7
0.213000	---	39.33	53.09	13.76	N	OFF	19.7
0.213000	49.76	---	63.09	13.33	N	OFF	19.7
0.235500	---	37.13	52.25	15.12	N	OFF	19.7
0.235500	42.51	---	62.25	19.74	N	OFF	19.7
0.503250	---	37.91	46.00	8.09	N	OFF	19.9
0.503250	41.00	---	56.00	15.00	N	OFF	19.9
0.568500	---	32.75	46.00	13.25	N	OFF	19.9
0.568500	38.61	---	56.00	17.39	N	OFF	19.9
1.286250	---	31.65	46.00	14.35	N	OFF	20.2
1.286250	40.50	---	56.00	15.50	N	OFF	20.2
1.353750	---	32.44	46.00	13.56	N	OFF	20.2

1.353750	41.68	---	56.00	14.32	N	OFF	20.2
1.446000	---	32.73	46.00	13.27	N	OFF	20.2
1.446000	41.70	---	56.00	14.30	N	OFF	20.2
1.524750	---	32.14	46.00	13.86	N	OFF	20.2
1.524750	40.98	---	56.00	15.02	N	OFF	20.2
1.623750	---	31.01	46.00	14.99	N	OFF	20.2
1.623750	40.06	---	56.00	15.94	N	OFF	20.2
14.214750	---	26.22	50.00	23.78	N	OFF	20.3
14.214750	31.13	---	60.00	28.87	N	OFF	20.3



Appendix C. Radiated Spurious Emission

Test Engineer :	Jesse Wang and Stan Hsieh	Temperature :	22.6~25.1°C
		Relative Humidity :	52.4~63.1%

2.4GHz 2400~2483.5MHz

BLE (Band Edge @ 3m)

BLE	Note	Frequency (MHz)	Level (dBμV/m)	Over Limit (dB)	Limit Line (dBμV/m)	Read Level (dBμV)	Antenna Factor (dB/m)	Path Loss (dB)	Preamp Factor (dB)	Ant Pos (cm)	Table Pos (deg)	Peak Avg. (P/A)	Pol. (H/V)	
BLE CH 00 2402MHz		2332.995	54.26	-19.74	74	40.01	31.77	17.87	35.39	276	68	P	H	
		2370.585	45.35	-8.65	54	30.87	31.87	18.02	35.41	276	68	A	H	
	*	2402	90.9	-	-	76.27	31.9	18.15	35.42	276	68	P	H	
	*	2402	90.36	-	-	75.73	31.9	18.15	35.42	276	68	A	H	
													H	
														H
			2345.91	54.45	-19.55	74	40.12	31.8	17.93	35.4	400	116	P	V
			2386.44	45.72	-8.28	54	31.13	31.9	18.1	35.41	400	116	A	V
	*		2402	91.47	-	-	76.84	31.9	18.15	35.42	400	116	P	V
	*		2402	90.8	-	-	76.17	31.9	18.15	35.42	400	116	A	V
BLE CH 19 2440MHz		2317.56	54.14	-19.86	74	39.96	31.77	17.8	35.39	313	68	P	H	
		2388.26	45.41	-8.59	54	30.82	31.9	18.1	35.41	313	68	A	H	
	*	2440	92.53	-	-	77.57	32.2	18.19	35.43	313	68	P	H	
	*	2440	91.94	-	-	76.98	32.2	18.19	35.43	313	68	A	H	
			2493.7	54.5	-19.5	74	39.12	32.6	18.24	35.46	313	68	P	H
			2488.17	46.27	-7.73	54	30.89	32.6	18.23	35.45	313	68	A	H
			2338.7	54.31	-19.69	74	40.01	31.8	17.89	35.39	301	101	P	V
			2385.04	45.44	-8.56	54	30.89	31.87	18.09	35.41	301	101	A	V
	*		2440	91.31	-	-	76.35	32.2	18.19	35.43	301	101	P	V
	*		2440	90.58	-	-	75.62	32.2	18.19	35.43	301	101	A	V
			2491.04	54.96	-19.04	74	39.57	32.6	18.24	35.45	301	101	P	V
			2491.39	46.4	-7.6	54	31.01	32.6	18.24	35.45	301	101	A	V



BLE CH 39 2480MHz	*	2480	93.98	-	-	78.73	32.47	18.23	35.45	300	49	P	H
	*	2480	92.32	-	-	77.07	32.47	18.23	35.45	300	49	A	H
		2497.92	55.62	-18.38	74	40.23	32.6	18.25	35.46	300	49	P	H
		2487.48	46.07	-7.93	54	30.82	32.47	18.23	35.45	300	49	A	H
													H
													H
	*	2480	92.44	-	-	77.19	32.47	18.23	35.45	300	99	P	V
	*	2480	91.83	-	-	76.58	32.47	18.23	35.45	300	99	A	V
		2497.48	54.94	-19.06	74	39.55	32.6	18.25	35.46	300	99	P	V
		2499.44	46.11	-7.89	54	30.72	32.6	18.25	35.46	300	99	A	V
													V
													V
Remark	1. No other spurious found. 2. All results are PASS against Peak and Average limit line.												



2.4GHz 2400~2483.5MHz
BLE (Harmonic @ 3m)

BLE	Note	Frequency (MHz)	Level (dBμV/m)	Over Limit (dB)	Limit Line (dBμV/m)	Read Level (dBμV)	Antenna Factor (dB/m)	Path Loss (dB)	Preamp Factor (dB)	Ant Pos (cm)	Table Pos (deg)	Peak Avg. (P/A)	Pol. (H/V)
BLE CH 00 2402MHz		4804	42.15	-31.85	74	53.81	34	12.33	57.99	100	0	P	H
													H
													H
													H
		4804	41.86	-32.14	74	53.52	34	12.33	57.99	100	0	P	V
													V
													V
BLE CH 19 2440MHz		4880	42.74	-31.26	74	54.13	34.1	12.41	57.9	100	0	P	H
		7320	40.82	-33.18	74	48.44	35.6	14.7	57.92	100	0	P	H
													H
													H
		4880	44.29	-29.71	74	55.68	34.1	12.41	57.9	100	0	P	V
		7320	41.29	-32.71	74	48.91	35.6	14.7	57.92	100	0	P	V
													V
BLE CH 39 2480MHz		4960	42.34	-31.66	74	53.45	34.2	12.5	57.81	100	0	P	H
		7440	40.44	-33.56	74	47.98	35.6	14.9	58.04	100	0	P	H
													H
													H
		4960	43.87	-30.13	74	54.98	34.2	12.5	57.81	100	0	P	V
		7440	40.96	-33.04	74	48.5	35.6	14.9	58.04	100	0	P	V
													V
Remark	1. No other spurious found.												
	2. All results are PASS against Peak and Average limit line.												



Emission below 1GHz
2.4GHz BLE (LF)

BLE	Note	Frequency (MHz)	Level (dBµV/m)	Over Limit (dB)	Limit Line (dBµV/m)	Read Level (dBµV)	Antenna Factor (dB/m)	Path Loss (dB)	Preamp Factor (dB)	Ant Pos (cm)	Table Pos (deg)	Peak Avg. (P/A)	Pol. (H/V)	
2.4GHz BLE LF		66.72	31.73	-8.27	40	48.23	11.93	1.57	30	-	-	P	H	
		152.31	35.45	-8.05	43.5	46.26	16.92	2.25	29.98	-	-	P	H	
		245.19	39.77	-6.23	46	49.43	17.64	2.67	29.97	100	0	P	H	
		713.7	36.96	-9.04	46	36.07	26.24	4.4	29.75	-	-	P	H	
		796.3	32.34	-13.66	46	29.48	27.81	4.65	29.6	-	-	P	H	
		953.8	33.91	-12.09	46	26.86	30.49	5.26	28.7	-	-	P	H	
														H
														H
														H
														H
														H
														H
														H
														H
														H
														H
														H
														H
														H
			30	33.16	-6.84	40	37.68	24.57	0.94	30.03	100	0	P	V
		66.72	31.36	-8.64	40	47.86	11.93	1.57	30	-	-	P	V	
		240.6	35.21	-10.79	46	45.41	17.11	2.66	29.97	-	-	P	V	
		717.9	37.15	-8.85	46	36.14	26.34	4.41	29.74	-	-	P	V	
		883.1	33.25	-12.75	46	28.62	28.67	4.98	29.02	-	-	P	V	
		953.1	34.61	-11.39	46	27.6	30.46	5.25	28.7	-	-	P	V	
													V	
													V	
													V	
													V	
													V	
													V	
													V	
Remark	1. No other spurious found. 2. All results are PASS against limit line.													



Note symbol

*	Fundamental Frequency which can be ignored. However, the level of any unwanted emissions shall not exceed the level of the fundamental frequency.
!	Test result is over limit line.
P/A	Peak or Average
H/V	Horizontal or Vertical



A calculation example for radiated spurious emission is shown as below:

BLE	Note	Frequency	Level	Over	Limit	Read	Antenna	Path	Preamp	Ant	Table	Peak	Pol.
		(MHz)	(dBμV/m)	(dB)	(dBμV/m)	(dBμV)	(dB/m)	(dB)	(dB)	(cm)	(deg)	(P/A)	(H/V)
BLE CH 00 2402MHz		2390	55.45	-18.55	74	54.51	32.22	4.58	35.86	103	308	P	H
		2390	43.54	-10.46	54	42.6	32.22	4.58	35.86	103	308	A	H

1. Path Loss(dB) = Cable loss(dB) + Filter loss(dB) + Attenuator loss(dB)
2. Level(dBμV/m) =
Antenna Factor(dB/m) + Path Loss(dB) + Read Level(dBμV) - Preamp Factor(dB)
3. Over Limit(dB) = Level(dBμV/m) – Limit Line(dBμV/m)

For Peak Limit @ 2390MHz:

1. Level(dBμV/m)
= Antenna Factor(dB/m) + Path Loss(dB) + Read Level(dBμV) - Preamp Factor(dB)
= 32.22(dB/m) + 4.58(dB) + 54.51(dBμV) – 35.86 (dB)
= 55.45 (dBμV/m)
2. Over Limit(dB)
= Level(dBμV/m) – Limit Line(dBμV/m)
= 55.45(dBμV/m) – 74(dBμV/m)
= -18.55(dB)

For Average Limit @ 2390MHz:

1. Level(dBμV/m)
= Antenna Factor(dB/m) + Path Loss(dB) + Read Level(dBμV) - Preamp Factor(dB)
= 32.22(dB/m) + 4.58(dB) + 42.6(dBμV) – 35.86 (dB)
= 43.54 (dBμV/m)
2. Over Limit(dB)
= Level(dBμV/m) – Limit Line(dBμV/m)
= 43.54(dBμV/m) – 54(dBμV/m)
= -10.46(dB)

Both peak and average measured complies with the limit line, so test result is “PASS”.



Appendix D. Radiated Spurious Emission Plots

Test Engineer :	Jesse Wang and Stan Hsieh	Temperature :	22.6~25.1°C
		Relative Humidity :	52.4~63.1%

Note symbol

-L	Low channel location
-R	High channel location



2.4GHz 2400~2483.5MHz

BLE (Band Edge @ 3m)

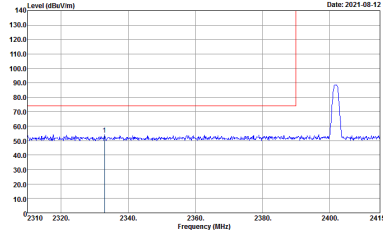
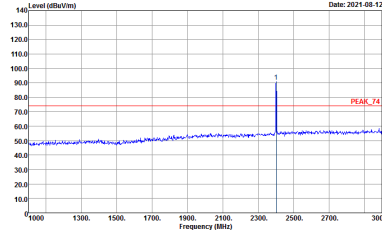
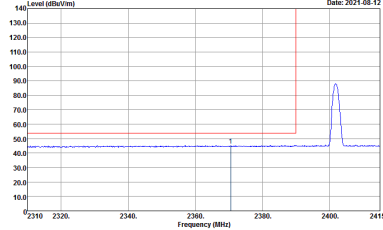
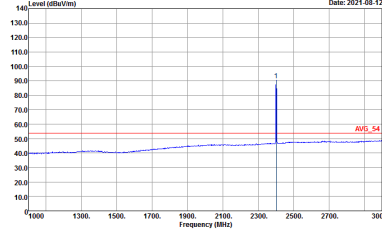
BLE	2.4GHz 2400~2483.5MHz Band Edge @ 3m	
	BLE CH00 2402MHz	
	Horizontal	Fundamental
Peak	 <p>Site : 03CH07-HY Condition : PEAK_BE_24.3m HF_ANT_00075962 HORIZONTAL : RBW:1000.000kHz VBW:3000.000kHz SWT:Auto</p>	 <p>Site : 03CH07-HY Condition : PEAK_24.3m HF_ANT_00075962 HORIZONTAL : RBW:1000.000kHz VBW:3000.000kHz SWT:Auto</p>
Avg.	 <p>Site : 03CH07-HY Condition : AVG_BE_S4 3m HF_ANT_00075962 HORIZONTAL : RBW:1000.000kHz VBW:3.000kHz SWT:Auto</p>	 <p>Site : 03CH07-HY Condition : AVG_S4 3m HF_ANT_00075962 HORIZONTAL : RBW:1000.000kHz VBW:3.000kHz SWT:Auto</p>

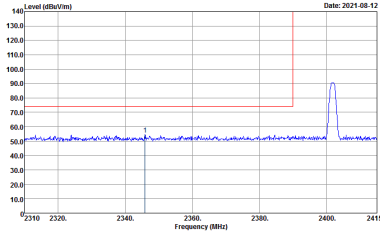
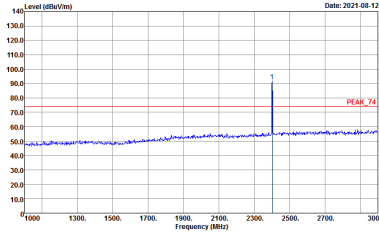
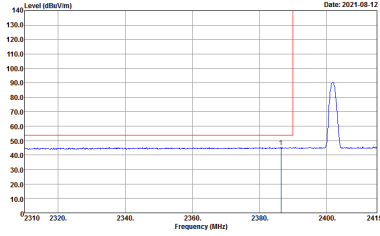
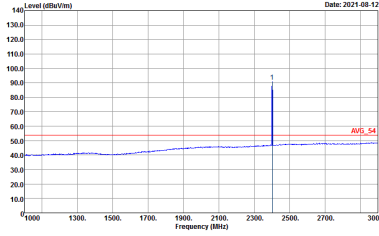

BLE	2.4GHz 2400~2483.5MHz Band Edge @ 3m	
BLE CH00 2402MHz		
Vertical		Fundamental
Peak	 <p>Level (dBu/m) vs Frequency (MHz) plot showing a peak at 2402 MHz. The y-axis ranges from 10.0 to 140.0 dBu/m, and the x-axis ranges from 2310 to 2415 MHz. A red line indicates the peak level at approximately 90 dBu/m.</p> <p>Site : 03CH07-HY Condition : PEAK_BE_24.3m HF_ANT_00075962 VERTICAL : RBW:1000.000kHz VBW:3000.000kHz SWT:Auto</p>	 <p>Level (dBu/m) vs Frequency (MHz) plot showing a peak at 2402 MHz. The y-axis ranges from 10.0 to 140.0 dBu/m, and the x-axis ranges from 1000 to 3000 MHz. A red line indicates the peak level at approximately 75 dBu/m, labeled 'PEAK_24'.</p> <p>Site : 03CH07-HY Condition : PEAK_24.3m HF_ANT_00075962 VERTICAL : RBW:1000.000kHz VBW:3000.000kHz SWT:Auto</p>
Avg	 <p>Level (dBu/m) vs Frequency (MHz) plot showing an average level at 2402 MHz. The y-axis ranges from 10.0 to 140.0 dBu/m, and the x-axis ranges from 2310 to 2415 MHz. A red line indicates the average level at approximately 50 dBu/m.</p> <p>Site : 03CH07-HY Condition : AVG_BE_24.3m HF_ANT_00075962 VERTICAL : RBW:1000.000kHz VBW:3.000kHz SWT:Auto</p>	 <p>Level (dBu/m) vs Frequency (MHz) plot showing an average level at 2402 MHz. The y-axis ranges from 10.0 to 140.0 dBu/m, and the x-axis ranges from 1000 to 3000 MHz. A red line indicates the average level at approximately 50 dBu/m, labeled 'AVG_24'.</p> <p>Site : 03CH07-HY Condition : AVG_24.3m HF_ANT_00075962 VERTICAL : RBW:1000.000kHz VBW:3.000kHz SWT:Auto</p>

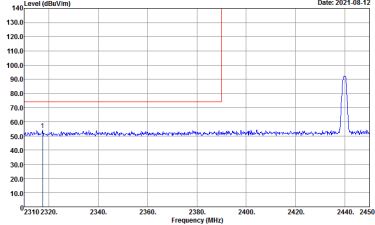
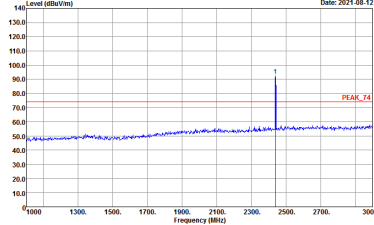
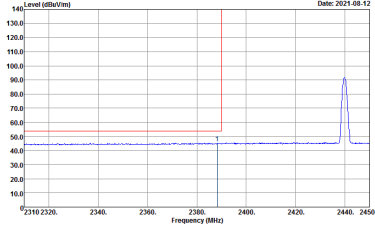
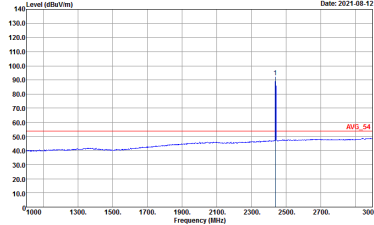

BLE	2.4GHz 2400~2483.5MHz Band Edge @ 3m	
BLE CH19 2440MHz - L		
Horizontal		Fundamental
Peak	 <p>Level (dBm/1m) vs Frequency (MHz) plot showing a peak at 2440 MHz. The y-axis ranges from 0 to 140 dBm/1m, and the x-axis ranges from 2310 to 2450 MHz. A red vertical line marks the peak at 2440 MHz.</p> <p>Site : 03CH07-HY Condition : PEAK_BE_24 3m HF_ANT_00075962 HORIZONTAL : RBW:1000.000kHz VBW:3000.000kHz SWT:Auto</p>	 <p>Level (dBm/1m) vs Frequency (MHz) plot showing a peak at 2440 MHz. The y-axis ranges from 0 to 140 dBm/1m, and the x-axis ranges from 1900 to 3000 MHz. A red horizontal line indicates the peak level, labeled 'PEAK_74'.</p> <p>Site : 03CH07-HY Condition : PEAK_24 3m HF_ANT_00075962 HORIZONTAL : RBW:1000.000kHz VBW:3000.000kHz SWT:Auto</p>
Avg.	 <p>Level (dBm/1m) vs Frequency (MHz) plot showing the average spectrum. The y-axis ranges from 0 to 140 dBm/1m, and the x-axis ranges from 2310 to 2450 MHz. A red vertical line marks the peak at 2440 MHz.</p> <p>Site : 03CH07-HY Condition : AVG_BE_54 3m HF_ANT_00075962 HORIZONTAL : RBW:1000.000kHz VBW:3.000kHz SWT:Auto</p>	 <p>Level (dBm/1m) vs Frequency (MHz) plot showing the average spectrum. The y-axis ranges from 0 to 140 dBm/1m, and the x-axis ranges from 1900 to 3000 MHz. A red horizontal line indicates the average level, labeled 'AVG_54'.</p> <p>Site : 03CH07-HY Condition : AVG_54 3m HF_ANT_00075962 HORIZONTAL : RBW:1000.000kHz VBW:3.000kHz SWT:Auto</p>

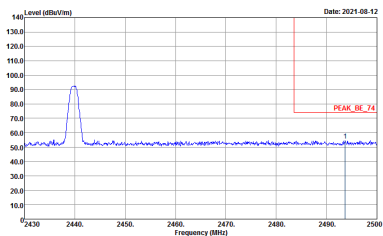
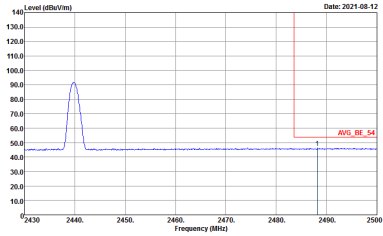

BLE	2.4GHz 2400~2483.5MHz Band Edge @ 3m	
BLE CH19 2440MHz - R		
	Horizontal	Fundamental
Peak	 <p>Site : 03CH07-HY Condition : :PEAK_BE_74 3m HF_ANT_00075962 HORIZONTAL : RBW:1000.000kHz VBW:3000.000kHz SWFAuto</p>	Left blank
Avg.	 <p>Site : 03CH07-HY Condition : :AVG_BE_54 3m HF_ANT_00075962 HORIZONTAL : RBW:1000.000kHz VBW:3.000kHz SWFAuto</p>	Left blank

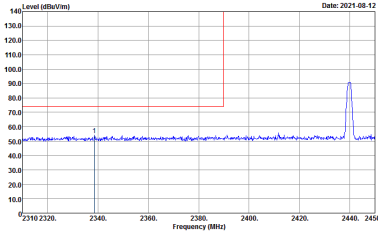
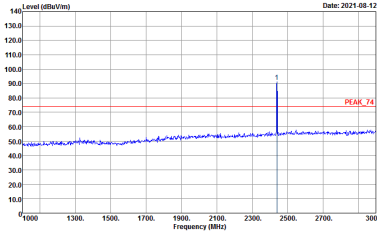
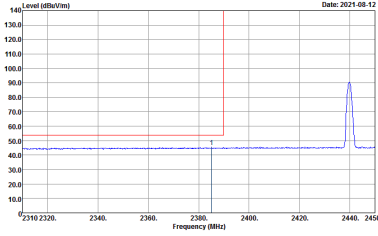
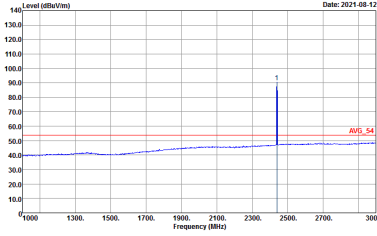

BLE	2.4GHz 2400~2483.5MHz Band Edge @ 3m	
BLE CH19 2440MHz - L		
Vertical		Fundamental
Peak	 <p>Level (dBu/m) vs Frequency (MHz) plot showing a peak at 2440 MHz. The y-axis ranges from 10.0 to 140.0 dBu/m, and the x-axis ranges from 2310 to 2450 MHz. A red line indicates the peak level at approximately 90 dBu/m.</p> <p>Site : 03CH07-HY Condition : PEAK_BE_24.3m HF_ANT_00075962 VERTICAL : RBW:1000.000kHz VBW:3000.000kHz SWT:Auto</p>	 <p>Level (dBu/m) vs Frequency (MHz) plot showing a peak at 2440 MHz. The y-axis ranges from 10.0 to 140.0 dBu/m, and the x-axis ranges from 1000 to 3000 MHz. A red line indicates the peak level at approximately 75 dBu/m.</p> <p>Site : 03CH07-HY Condition : PEAK_24.3m HF_ANT_00075962 VERTICAL : RBW:1000.000kHz VBW:3000.000kHz SWT:Auto</p>
Avg.	 <p>Level (dBu/m) vs Frequency (MHz) plot showing an average level at 2440 MHz. The y-axis ranges from 10.0 to 140.0 dBu/m, and the x-axis ranges from 2310 to 2450 MHz. A red line indicates the average level at approximately 50 dBu/m.</p> <p>Site : 03CH07-HY Condition : AVG_BE_24.3m HF_ANT_00075962 VERTICAL : RBW:1000.000kHz VBW:3.000kHz SWT:Auto</p>	 <p>Level (dBu/m) vs Frequency (MHz) plot showing an average level at 2440 MHz. The y-axis ranges from 10.0 to 140.0 dBu/m, and the x-axis ranges from 1000 to 3000 MHz. A red line indicates the average level at approximately 50 dBu/m.</p> <p>Site : 03CH07-HY Condition : AVG_24.3m HF_ANT_00075962 VERTICAL : RBW:1000.000kHz VBW:3.000kHz SWT:Auto</p>

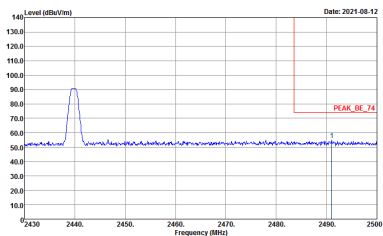
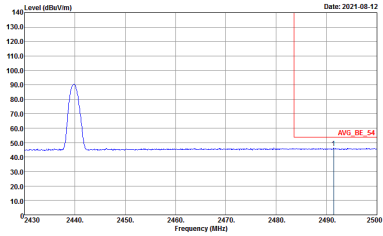

BLE	2.4GHz 2400~2483.5MHz Band Edge @ 3m	
BLE CH19 2440MHz - R		
	Vertical	Fundamental
Peak	 <p>Site : 03CH07-HY Condition : PEAK_BE_74 3m HF_ANT_00075962 VERTICAL : RBW:1000.000kHz VBW:3000.000kHz SWFAuto</p>	Left blank
Avg.	 <p>Site : 03CH07-HY Condition : AVG_BE_54 3m HF_ANT_00075962 VERTICAL : RBW:1000.000kHz VBW:3.000kHz SWFAuto</p>	Left blank

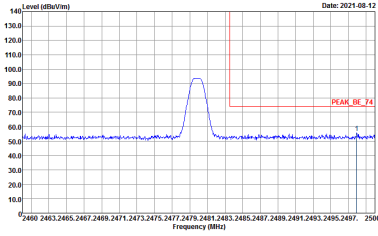
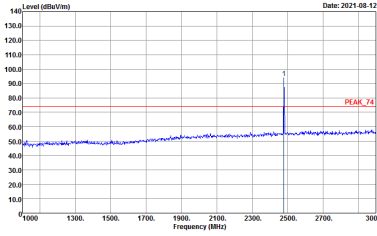
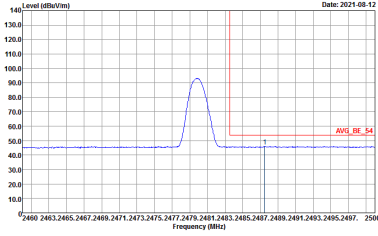
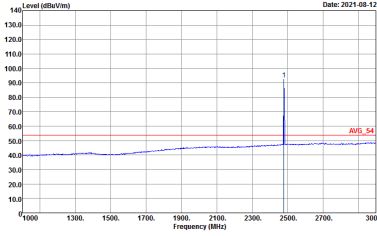

BLE	2.4GHz 2400~2483.5MHz Band Edge @ 3m	
BLE CH39 2480MHz		
Horizontal		Fundamental
Peak	 <p>Level (dBuV/m) vs Frequency (MHz) plot showing a peak at 2480 MHz. The peak level is approximately 95 dBuV/m. The plot includes a red horizontal line labeled 'PEAK_BE_Y4' at the peak level. The x-axis ranges from 2460 to 2500 MHz, and the y-axis ranges from 10.0 to 140.0 dBuV/m.</p> <p>Site : 03CH07-HY Condition : :PEAK_BE_24.3m HF_ANT_00075962 HORIZONTAL : RBW:1000.000kHz VBW:3000.000kHz SWT:Auto</p>	 <p>Level (dBuV/m) vs Frequency (MHz) plot showing a sharp peak at 2480 MHz. The peak level is approximately 95 dBuV/m. The plot includes a red horizontal line labeled 'PEAK_Y4' at the peak level. The x-axis ranges from 1000 to 3000 MHz, and the y-axis ranges from 10.0 to 140.0 dBuV/m.</p> <p>Site : 03CH07-HY Condition : :PEAK_24.3m HF_ANT_00075962 HORIZONTAL : RBW:1000.000kHz VBW:3000.000kHz SWT:Auto</p>
Avg.	 <p>Level (dBuV/m) vs Frequency (MHz) plot showing the average level across the band. A peak is visible at 2480 MHz. The plot includes a red horizontal line labeled 'AVG_BE_S4' at the peak level. The x-axis ranges from 2460 to 2500 MHz, and the y-axis ranges from 10.0 to 140.0 dBuV/m.</p> <p>Site : 03CH07-HY Condition : :AVG_BE_S4.3m HF_ANT_00075962 HORIZONTAL : RBW:1000.000kHz VBW:3.000kHz SWT:Auto</p>	 <p>Level (dBuV/m) vs Frequency (MHz) plot showing the average level across the band. A sharp peak is visible at 2480 MHz. The plot includes a red horizontal line labeled 'AVG_S4' at the peak level. The x-axis ranges from 1000 to 3000 MHz, and the y-axis ranges from 10.0 to 140.0 dBuV/m.</p> <p>Site : 03CH07-HY Condition : :AVG_S4.3m HF_ANT_00075962 HORIZONTAL : RBW:1000.000kHz VBW:3.000kHz SWT:Auto</p>

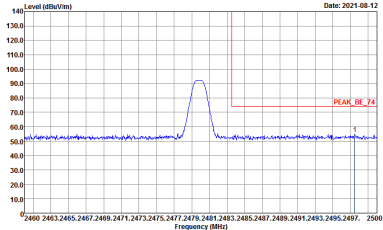
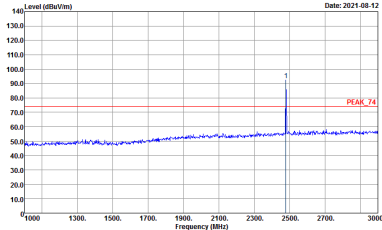
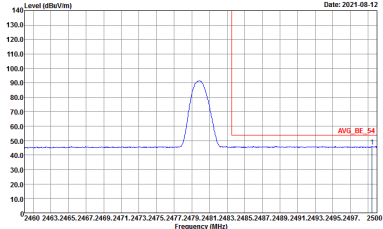
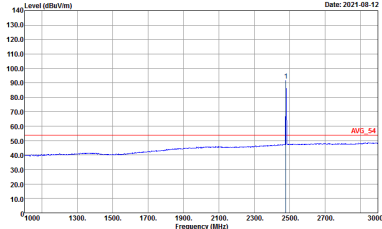

BLE	2.4GHz 2400~2483.5MHz Band Edge @ 3m	
BLE CH39 2480MHz		
Vertical		Fundamental
Peak	 <p>Level (dBuV/m) vs Frequency (MHz) plot showing a peak at 2480 MHz. The peak level is approximately 95 dBuV/m. The plot includes a red line indicating the peak level and a blue line for the signal. The x-axis ranges from 2400 to 2500 MHz, and the y-axis ranges from 10.0 to 140.0 dBuV/m.</p> <p>Site : 03CH07-HY Condition : :PEAK_BE_34 3m HF_ANT_00075962 VERTICAL : RBW:1000.000kHz VBW:3000.000kHz SWT:Auto</p>	 <p>Level (dBuV/m) vs Frequency (MHz) plot showing a peak at 2480 MHz. The peak level is approximately 95 dBuV/m. The plot includes a red line indicating the peak level and a blue line for the signal. The x-axis ranges from 1000 to 3000 MHz, and the y-axis ranges from 10.0 to 140.0 dBuV/m.</p> <p>Site : 03CH07-HY Condition : :PEAK_34 3m HF_ANT_00075962 VERTICAL : RBW:1000.000kHz VBW:3000.000kHz SWT:Auto</p>
Avg.	 <p>Level (dBuV/m) vs Frequency (MHz) plot showing the average level of the signal. The average level is approximately 50 dBuV/m. The plot includes a red line indicating the average level and a blue line for the signal. The x-axis ranges from 2400 to 2500 MHz, and the y-axis ranges from 10.0 to 140.0 dBuV/m.</p> <p>Site : 03CH07-HY Condition : :AVG_BE_34 3m HF_ANT_00075962 VERTICAL : RBW:1000.000kHz VBW:3.000kHz SWT:Auto</p>	 <p>Level (dBuV/m) vs Frequency (MHz) plot showing the average level of the signal. The average level is approximately 50 dBuV/m. The plot includes a red line indicating the average level and a blue line for the signal. The x-axis ranges from 1000 to 3000 MHz, and the y-axis ranges from 10.0 to 140.0 dBuV/m.</p> <p>Site : 03CH07-HY Condition : :AVG_34 3m HF_ANT_00075962 VERTICAL : RBW:1000.000kHz VBW:3.000kHz SWT:Auto</p>



2.4GHz 2400~2483.5MHz

BLE (Harmonic @ 3m)

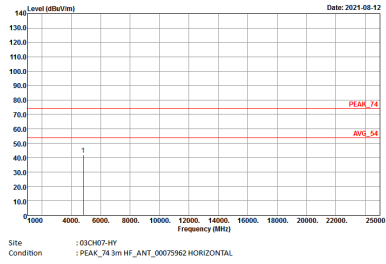
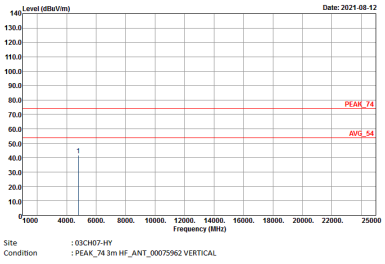
BLE	2.4GHz 2400~2483.5MHz Harmonic @ 3m	
	BLE CH00 2402MHz	
	Horizontal	Vertical
Peak Avg.	 <p>Date: 2021-08-12</p> <p>Site Condition :03CH07-HY : PEAK_74 3m HF_ANT_00075962 HORIZONTAL</p>	 <p>Date: 2021-08-12</p> <p>Site Condition :03CH07-HY : PEAK_74 3m HF_ANT_00075962 VERTICAL</p>

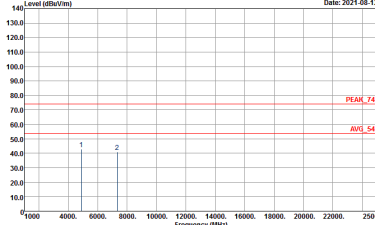
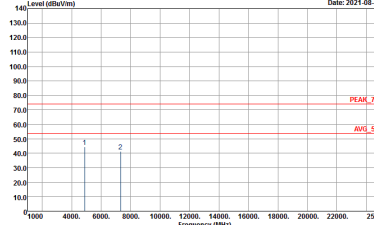

BLE	2.4GHz 2400~2483.5MHz Harmonic @ 3m	
	BLE CH19 2440MHz	
	Horizontal	Vertical
Peak Avg.	 <p>Site : 03CH07-HY Condition : PEAK_74 3m HF_ANT_00075962 HORIZONTAL</p>	 <p>Site : 03CH07-HY Condition : PEAK_74 3m HF_ANT_00075962 VERTICAL</p>

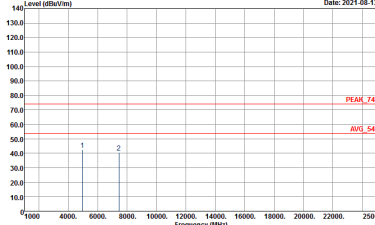
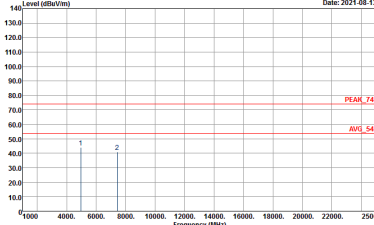

BLE	2.4GHz 2400~2483.5MHz Harmonic @ 3m	
	BLE CH39 2480MHz	
	Horizontal	Vertical
Peak Avg.	 <p>Site : 03CH07-HY Condition : PEAK_74 3m HF_ANT_00075962 HORIZONTAL</p>	 <p>Site : 03CH07-HY Condition : PEAK_74 3m HF_ANT_00075962 VERTICAL</p>



Emission below 1GHz

2.4GHz BLE (LF)

BLE	2.4GHz 2400~2483.5MHz	
	BLE LF	
	Horizontal	Vertical
QP / Peak	<p>Site : :03CH07-HY Condition : :QP 3m LF-ANT-35415(6) HORIZONTAL</p>	<p>Site : :03CH07-HY Condition : :QP 3m LF-ANT-35415(6) VERTICAL</p>



Appendix E. Duty Cycle Plots

Band	Duty Cycle(%)	T(us)	1/T(kHz)	VBW Setting
Bluetooth - LE for 1Mbps	64.90	405	2.47	3kHz

