



FCC RADIO TEST REPORT

FCC ID : 2AP4W-VLITE
Equipment : mPERS
Brand Name : Belle
Model Name : Belle X VZW
Marketing Name : Belle X
Applicant : Freeus, LLC
1069 Stewart Dr, Suites 3-6 Ogden, Utah
84404, United States
Manufacturer : WiBASE Industrial Solutions Inc.
Bldg. G, 17F, No. 3-1, Yuan Qu St., Nan
Gang Dist., Taipei City, 115, Taiwan.
Standard : FCC 47 CFR Part 2, 22(H), 24(E), 27

The product was received on Jul. 30, 2021 and testing was started from Aug. 03, 2021 and completed on Aug. 15, 2021. We, Sporton International Inc. EMC & Wireless Communications Laboratory, would like to declare that the tested sample has been evaluated in accordance with the test procedures given in ANSI / TIA-603-E and has been in compliance with the applicable technical standards.

The test results in this variant report apply exclusively to the tested model / sample. Without written approval of Sporton International Inc. EMC & Wireless Communications Laboratory, the test report shall not be reproduced except in full.

Louis Wu

Approved by: Louis Wu

Sporton International Inc. EMC & Wireless Communications Laboratory

No. 52, Huaya 1st Rd., Guishan Dist., Taoyuan City 333, Taiwan (R.O.C.)



Table of Contents

History of this test report.....	3
Summary of Test Result.....	4
1 General Description	6
1.1 Product Feature of Equipment Under Test.....	6
1.2 Modification of EUT	6
1.3 Testing Location	6
1.4 Applicable Standards.....	7
2 Test Configuration of Equipment Under Test	8
2.1 Test Mode.....	8
2.2 Connection Diagram of Test System.....	9
2.3 Support Unit used in test configuration and system	9
2.4 Measurement Results Explanation Example.....	9
2.5 Frequency List of Low/Middle/High Channels	10
3 Conducted Test Items.....	12
3.1 Measuring Instruments	12
3.2 Conducted Output Power and ERP/EIRP	13
3.3 Conducted Band Edge	14
3.4 Conducted Spurious Emission	16
4 Radiated Test Items	17
4.1 Measuring Instruments	17
4.2 Radiated Spurious Emission Measurement	19
5 List of Measuring Equipment.....	20
6 Uncertainty of Evaluation.....	21
Appendix A. Test Results of Conducted Test	
Appendix B. Test Results of Radiated Test	
Appendix C. Test Setup Photographs	



History of this test report

Report No.	Version	Description	Issued Date
FG982310-04	01	Initial issue of report	Aug. 27, 2021
FG982310-04	02	Revise applicant address	Sep. 07, 2021



Summary of Test Result

Report Clause	Ref Std. Clause	Test Items	Result (PASS/FAIL)	Remark
3.2	§2.1046	Conducted Output Power	Reporting only	-
	§22.913 (a)(5)	Effective Radiated Power (Band 5)	Pass	
	§27.50 (b)(10)	Effective Radiated Power (Band 13)		
	§24.232 (c)	Equivalent Isotropic Radiated Power (Band 2)		
	§27.50 (d)(4)	Equivalent Isotropic Radiated Power (Band 4)		
-	§24.232 (d) §27.50 (d)(5)	Peak-to-Average Ratio	Not Required	-
-	§2.1049	Occupied Bandwidth	Not Required	-
3.3	§2.1051 §22.917 (a) §24.238 (a) §27.53 (c)(2)(4) §27.53 (h)	Conducted Band Edge Measurement (Band 2) (Band 4) (Band 5) (Band 13)	Pass	-
3.4	§2.1051 §22.917 (a) §24.238 (a) §27.53 (c)(2) §27.53 (h)	Conducted Spurious Emission (Band 2) (Band 4) (Band 5) (Band 13)	Pass	-
-	§2.1055 §22.355 §24.235 §27.54	Frequency Stability Temperature & Voltage	Not Required	-
4.2	§2.1053 §22.917 (a) §24.238 (a) §27.53 (c)(2) §27.53 (f) §27.53 (h)	Radiated Spurious Emission (Band 2) (Band 4) (Band 5) (Band 13)	Pass	Under limit 14.49 dB at 1560.000 MHz

Remark:

1. Not required means after assessing, test items are not necessary to carry out.
2. This is a variant report by changing WWAN PA (Pin to Pin), LTE band 2 Duplexer 2nd Source and turning on Bluetooth-LE function via SW. All the test cases were performed on original report which can be referred to Sporton Report Number FG982310-02. Based on the original report, the test cases were verified.



Declaration of Conformity:
The test results with all measurement uncertainty excluded are presented in accordance with the regulation limits or requirements declared by manufacturers.
Comments and Explanations:
The declared of product specification for EUT presented in the report are provided by the manufacturer, and the manufacturer takes all the responsibilities for the accuracy of product specification.

Reviewed by: Yun Huang
Report Producer: Ruby Zou



1 General Description

1.1 Product Feature of Equipment Under Test

LTE, Bluetooth-LE, Wi-Fi 2.4GHz 802.11b/g/n, and GNSS.

Product Specification subjective to this standard	
Antenna Type	WWAN <Main>: LDS Antenna <Div.>: LDS Antenna WLAN: LDS Antenna Bluetooth-LE: LDS Antenna GPS/Glonass: LDS Antenna
Antenna Gain	<Main>: LTE Band 2: -2.7 dBi LTE Band 4: -5.3 dBi LTE Band 5: -5.4 dBi LTE Band 13: -7.9 dBi <Div.>: LTE Band 2: -5.2 dBi LTE Band 4: -6.5 dBi LTE Band 5: -13.0 dBi LTE Band 13: -16.4 dBi

Remark: The above EUT's information was declared by manufacturer. Please refer to Comments and Explanations in report summary.

1.2 Modification of EUT

No modifications are made to the EUT during all test items.

1.3 Testing Location

Test Site	Sporton International Inc. EMC & Wireless Communications Laboratory	
Test Site Location	No.52, Huaya 1st Rd., Guishan Dist., Taoyuan City 333, Taiwan (R.O.C.) TEL: +886-3-327-3456 FAX: +886-3-328-4978	
Test Site No.	Sporton Site No.	
	TH02-HY	03CH07-HY
Test Engineer	Benjamin Lin	Jesse Wang and Stan Hsieh
Temperature	25.3~27.5°C	19~22°C
Relative Humidity	49.4~52.2%	51~56%

Note: The test site complies with ANSI C63.4 2014 requirement.

FCC Designation No.: TW1190



1.4 Applicable Standards

According to the specifications of the manufacturer, the EUT must comply with the requirements of the following standards:

- ♦ ANSI C63.26-2015
- ♦ ANSI / TIA-603-E
- ♦ FCC 47 CFR Part 2, 22(H), 24(E), 27
- ♦ FCC KDB 971168 D01 Power Meas. License Digital Systems v03r01
- ♦ FCC KDB 412172 D01 Determining ERP and EIRP v01r01
- ♦ FCC KDB 414788 D01 Radiated Test Site v01r01.

Remark:

1. All test items were verified and recorded according to the standards and without any deviation during the test.
2. This EUT has also been tested and complied with the requirements of FCC Part 15, Subpart B, recorded in a separate test report.
3. The TAF code is not including all the FCC KDB listed without accreditation.



2 Test Configuration of Equipment Under Test

2.1 Test Mode

Antenna port conducted and radiated test items listed below are performed according to KDB 971168 D01 Power Meas. License Digital Systems v03r01 with maximum output power.

Test Items	Band	Bandwidth (MHz)						Modulation			RB #			Test Channel		
		1.4	3	5	10	15	20	QPSK	16QAM	64QAM	1	Half	Full	L	M	H
Max. Output Power	2	v	v	v	v	v	v	v	v		v	v	v	v	v	v
	4	v	v	v	v	v	v	v	v		v	v	v	v	v	v
	5	v	v	v	v	-	-	v	v		v	v	v	v	v	v
	13	-	-	v	v	-	-	v	v		v	v	v	v	v	v
Conducted Band Edge	2	v	v	v	v	v	v	v	v		v		v	v		v
	4	v	v	v	v	v	v	v	v		v		v	v		v
	5	v	v	v	v	-	-	v	v		v		v	v		v
	13	-	-	v	v	-	-	v	v		v		v	v		v
Conducted Spurious Emission	2	v	v	v	v	v	v	v			v			v	v	v
	4	v	v	v	v	v	v	v			v			v	v	v
	5	v	v	v	v	-	-	v			v			v	v	v
	13	-	-	v	v	-	-	v			v			v	v	v
E.R.P / E.I.R.P	2	v	v	v	v	v	v	v	v		Max Power					
	4	v	v	v	v	v	v	v	v							
	5	v	v	v	v	-	-	v	v							
	13	-	-	v	v	-	-	v	v							
Radiated Spurious Emission	2	Worst Case												v		
	4	Worst Case												v		
	5	Worst Case													v	
	13	Worst Case												v		
Remark	<ol style="list-style-type: none"> The mark "v" means that this configuration is chosen for testing The mark "-" means that this bandwidth is not supported. The device is investigated from 30MHz to 10 times of fundamental signal for radiated spurious emission test under different RB size/offset and modulations in exploratory test. Subsequently, only the worst case emissions are reported. All the radiated test cases were performed with AC Adapter with Charging Cradle (Black) 															

2.2 Connection Diagram of Test System

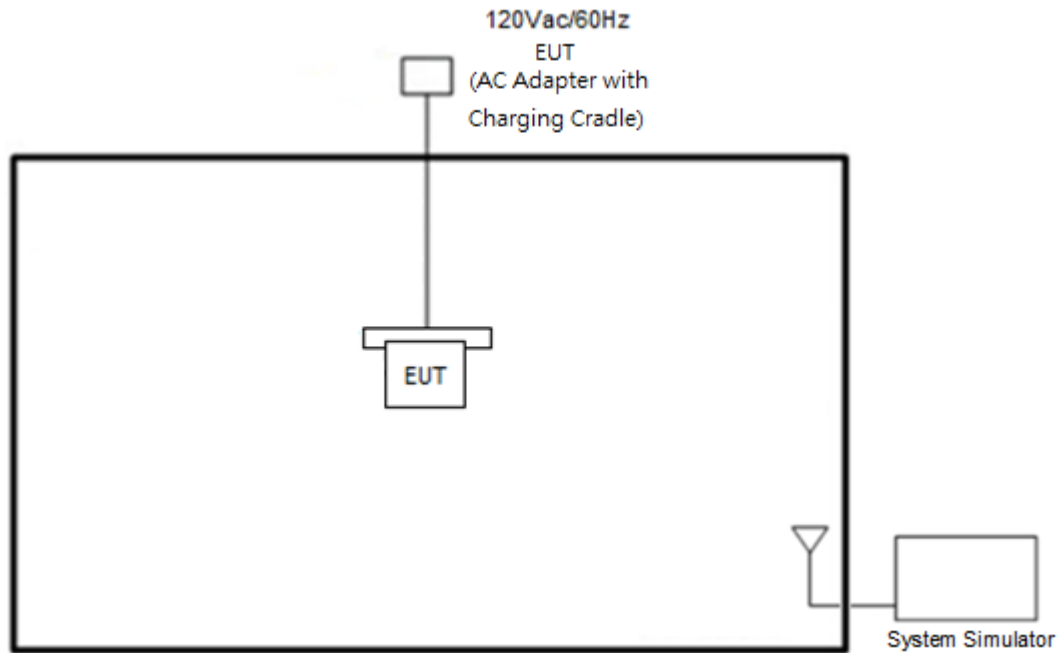

2.3 Support Unit used in test configuration and system

Item	Equipment	Brand Name	Model No.	FCC ID	Data Cable	Power Cord
1.	System Simulator	Anritsu	MT8820C	N/A	N/A	Unshielded, 1.8 m

2.4 Measurement Results Explanation Example

For all conducted test items:

The offset level is set in the spectrum analyzer to compensate the RF cable loss and attenuator factor between EUT conducted output port and spectrum analyzer. With the offset compensation, the spectrum analyzer reading level is exactly the EUT RF output level.

The spectrum analyzer offset is derived from RF cable loss and attenuator factor.

Offset = RF cable loss + attenuator factor.

Following shows an offset computation example with cable loss 4.2 dB and 10dB attenuator.

Example :

Offset(dB) = RF cable loss(dB) + attenuator factor(dB).

$$= 4.2 + 10 = 14.2 \text{ (dB)}$$



2.5 Frequency List of Low/Middle/High Channels

LTE Band 2 Channel and Frequency List				
BW [MHz]	Channel/Frequency(MHz)	Lowest	Middle	Highest
20	Channel	18700	18900	19100
	Frequency	1860	1880	1900
15	Channel	18675	18900	19125
	Frequency	1857.5	1880	1902.5
10	Channel	18650	18900	19150
	Frequency	1855	1880	1905
5	Channel	18625	18900	19175
	Frequency	1852.5	1880	1907.5
3	Channel	18615	18900	19185
	Frequency	1851.5	1880	1908.5
1.4	Channel	18607	18900	19193
	Frequency	1850.7	1880	1909.3

LTE Band 4 Channel and Frequency List				
BW [MHz]	Channel/Frequency(MHz)	Lowest	Middle	Highest
20	Channel	20050	20175	20300
	Frequency	1720	1732.5	1745
15	Channel	20025	20175	20325
	Frequency	1717.5	1732.5	1747.5
10	Channel	20000	20175	20350
	Frequency	1715	1732.5	1750
5	Channel	19975	20175	20375
	Frequency	1712.5	1732.5	1752.5
3	Channel	19965	20175	20385
	Frequency	1711.5	1732.5	1753.5
1.4	Channel	19957	20175	20393
	Frequency	1710.7	1732.5	1754.3



LTE Band 5 Channel and Frequency List				
BW [MHz]	Channel/Frequency(MHz)	Lowest	Middle	Highest
10	Channel	20450	20525	20600
	Frequency	829	836.5	844
5	Channel	20425	20525	20625
	Frequency	826.5	836.5	846.5
3	Channel	20415	20525	20635
	Frequency	825.5	836.5	847.5
1.4	Channel	20407	20525	20643
	Frequency	824.7	836.5	848.3

LTE Band 13 Channel and Frequency List				
BW [MHz]	Channel/Frequency(MHz)	Lowest	Middle	Highest
10	Channel	-	23230	-
	Frequency	-	782	-
5	Channel	23205	23230	23255
	Frequency	779.5	782	784.5

3 Conducted Test Items

3.1 Measuring Instruments

See list of measuring instruments of this test report.

3.1.1 Test Setup

3.1.2 Conducted Output Power

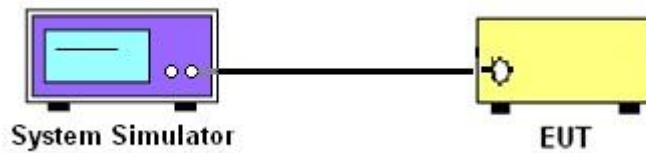

3.1.3 Conducted Band-Edge and Conducted Spurious Emission

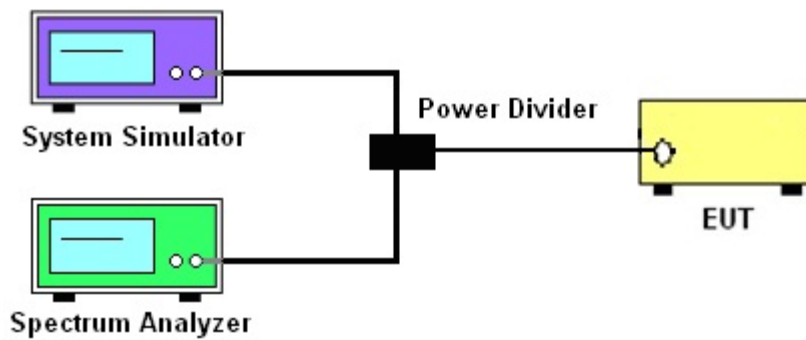

3.1.4 Test Result of Conducted Test

Please refer to Appendix A.



3.2 Conducted Output Power and ERP/EIRP

3.2.1 Description of the Conducted Output Power Measurement and ERP/EIRP Measurement

A system simulator was used to establish communication with the EUT. Its parameters were set to force the EUT transmitting at maximum output power. The measured power in the radio frequency on the transmitter output terminals shall be reported.

The ERP of mobile transmitters must not exceed 7 Watts for LTE Band 5

The ERP of mobile transmitters must not exceed 3 Watts for LTE Band 13

The EIRP of mobile transmitters must not exceed 2 Watts for LTE Band 2

The EIRP of mobile transmitters must not exceed 1 Watts for LTE Band 4

According to KDB 412172 D01 Power Approach,

$EIRP = P_T + G_T - L_C$, $ERP = EIRP - 2.15$, where

P_T = transmitter output power in dBm

G_T = gain of the transmitting antenna in dBi

L_C = signal attenuation in the connecting cable between the transmitter and antenna in dB

3.2.2 Test Procedures

1. The transmitter output port was connected to the system simulator.
2. Set EUT at maximum power through the system simulator.
3. Select lowest, middle, and highest channels for each band and different modulation.
4. Measure and record the power level from the system simulator.



3.3 Conducted Band Edge

3.3.1 Description of Conducted Band Edge Measurement

22.917(a)

For operations in the 824 – 849 MHz band, the FCC limit is $43 + 10\log_{10}(P[\text{Watts}])$ dB below the transmitter power $P(\text{Watts})$ in a 100kHz bandwidth. However, in the 1MHz bands immediately outside and adjacent to the licensee's frequency block, a resolution bandwidth of at least one percent of the emission bandwidth of the fundamental emission of the transmitter may be employed.

24.238 (a)

For operations in the 1850-1910 and 1930-1990 MHz band, the FCC limit is $43 + 10\log_{10}(P[\text{Watts}])$ dB below the transmitter power $P(\text{Watts})$ in a 1MHz bandwidth. However, in the 1 MHz bands immediately outside and adjacent to the frequency block a resolution bandwidth of at least one percent of the emission bandwidth of the fundamental emission of the transmitter may be employed.

27.53 (c)

For operations in the 776-788 MHz band, the FCC limit is $43 + 10\log_{10}(P[\text{Watts}])$ dB below the transmitter power $P(\text{Watts})$ in a 100 kHz bandwidth. However, in the 100 kHz bands immediately outside and adjacent to the frequency block, a resolution bandwidth of at least 30 kHz may be employed. In addition, the power of any unwanted emissions in any 6.25 kHz bandwidth for all frequencies between 763-775 MHz and 793-806 MHz shall be attenuated below the transmitter power, P (dBW), by at least $65 + 10 \log_{10} p(\text{watts})$, dB, for mobile and portable equipment.

27.53 (h)

For operations in the 1710 – 1755 MHz band, 1755-1780 MHz, the FCC limit is $43 + 10\log_{10}(P[\text{Watts}])$ dB below the transmitter power $P(\text{Watts})$ in a 1 MHz bandwidth. However, in the 1MHz bands immediately outside and adjacent to the licensee's frequency block, a resolution bandwidth of at least one percent of the emission bandwidth of the fundamental emission of the transmitter may be employed.



3.3.2 Test Procedures

The testing follows FCC KDB 971168 D01 v03r01 Section 6.1.

1. The EUT was connected to spectrum analyzer and system simulator via a power divider.
2. The band edges of low and high channels for the highest RF powers were measured.
3. Set RBW \geq 1% EBW in the 1MHz band immediately outside and adjacent to the band edge.
4. Beyond the 1 MHz band from the band edge, RBW=1MHz was used.
5. Set spectrum analyzer with RMS detector.
6. The RF fundamental frequency should be excluded against the limit line in the operating frequency band.
7. Checked that all the results comply with the emission limit line.

The limit line is derived from $43 + 10\log(P)$ dB below the transmitter power P(Watts)



3.4 Conducted Spurious Emission

3.4.1 Description of Conducted Spurious Emission Measurement

The power of any emission outside of the authorized operating frequency ranges must be lower than the transmitter power (P) by a factor of at least $43 + 10 \log (P)$ dB.

It is measured by means of a calibrated spectrum analyzer and scanned from 30 MHz up to a frequency including its 10th harmonic.

3.4.2 Test Procedures

The testing follows FCC KDB 971168 D01 v03r01 Section 6.1.

1. The EUT was connected to spectrum analyzer and system simulator via a power divider.
2. The RF output of EUT was connected to the spectrum analyzer by RF cable and attenuator. The path loss was compensated to the results for each measurement.
3. The middle channel for the highest RF power within the transmitting frequency was measured.
4. The conducted spurious emission for the whole frequency range was taken.
5. Make the measurement with the spectrum analyzer's RBW = 1MHz, VBW = 3MHz.
6. Set spectrum analyzer with RMS detector.
7. Taking the record of maximum spurious emission.
8. The RF fundamental frequency should be excluded against the limit line in the operating frequency band.
9. The limit line is derived from $43 + 10\log(P)$ dB below the transmitter power P(Watts)

4 Radiated Test Items

4.1 Measuring Instruments

See list of measuring instruments of this test report.

4.1.1 Test Setup

For radiated test below 30MHz

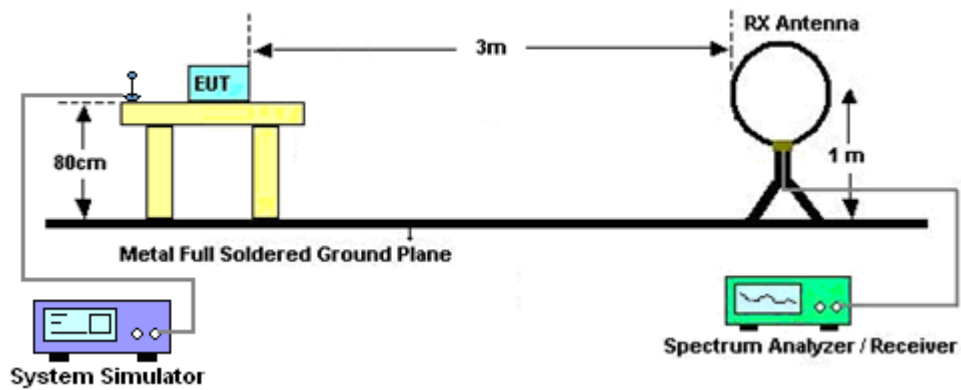

For radiated test from 30MHz to 1GHz

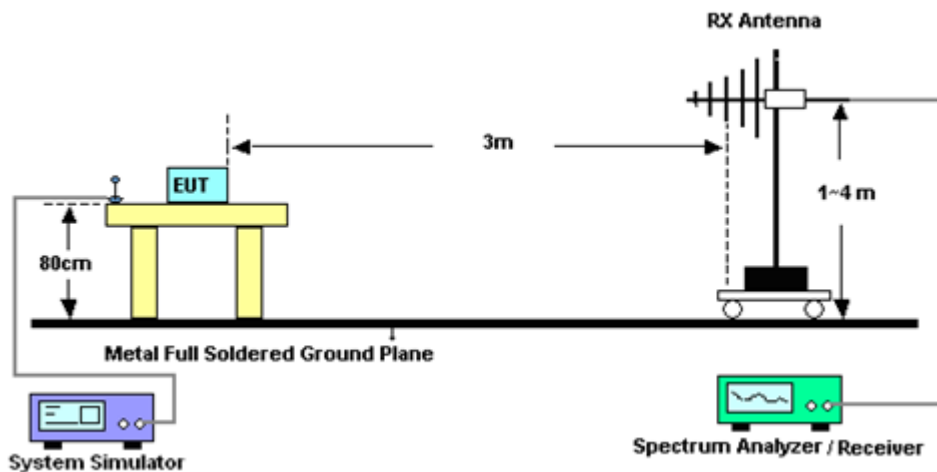

For radiated test from 1GHz to 18GHz

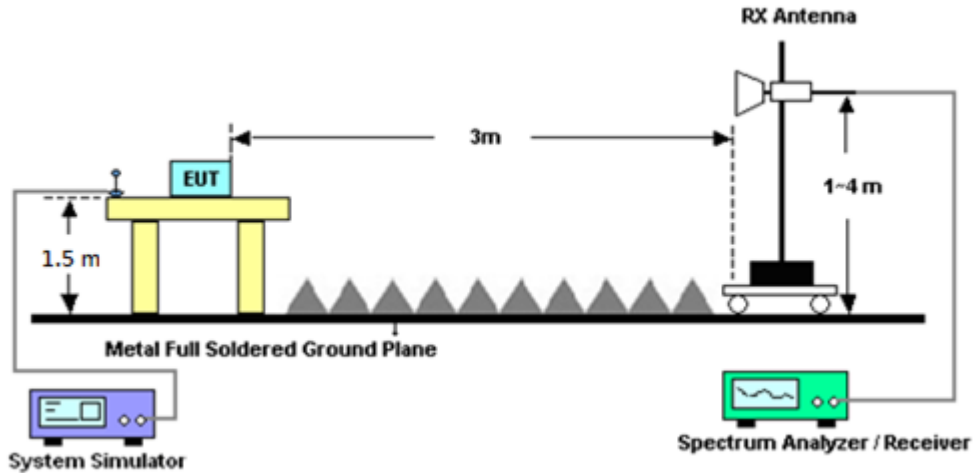

4.1.2 Test Result of Radiated Test

Please refer to Appendix B.

Note:

The low frequency, which started from 9 kHz to 30MHz, was pre-scanned and the result which was 20dB lower than the limit line was not reported.

There is adequate comparison measurement of both open-field test site and alternative test site - semi-Anechoic chamber according to 414788 D01 Radiated Test Site v01r01, and the result came out very similar.



4.2 Radiated Spurious Emission Measurement

4.2.1 Description of Radiated Spurious Emission Measurement

The radiated spurious emission was measured by substitution method according to ANSI / TIA-603-E. The power of any emission outside of the authorized operating frequency ranges must be attenuated below the transmitter power (P) by a factor of at least $43 + 10 \log (P)$ dB.

For LTE Band 13

For operations in the 746-758 MHz, 775-788 MHz, and 805-806 MHz bands, emissions in the band 1559-1610 MHz shall be limited to -70 dBW/MHz equivalent isotropically radiated power (EIRP) for wideband signals, and -80 dBW EIRP for discrete emissions of less than 700 Hz bandwidth.

The spectrum is scanned from 30 MHz up to a frequency including its 10th harmonic.

4.2.2 Test Procedures

The testing follows FCC KDB 971168 D01 v03r01 Section 7 and ANSI / TIA-603-E Section 2.2.12.

1. The EUT was placed on a turntable with 0.8 meter for frequency below 1GHz and 1.5 meter for frequency above 1GHz respectively above ground.
2. The EUT was set 3 meters from the receiving antenna, which was mounted on the antenna tower.
3. The table was rotated 360 degrees to determine the position of the highest spurious emission.
4. The height of the receiving antenna is varied between one meter and four meters to search the maximum spurious emission for both horizontal and vertical polarizations.
5. Make the measurement with the spectrum analyzer's RBW = 1MHz, VBW = 3MHz, taking the record of maximum spurious emission.
6. A horn antenna was substituted in place of the EUT and was driven by a signal generator.
7. Tune the output power of signal generator to the same emission level with EUT maximum spurious emission.
8. Taking the record of output power at antenna port.
9. Repeat step 7 to step 8 for another polarization.
10. The RF fundamental frequency should be excluded against the limit line in the operating frequency band.

The limit line is derived from $43 + 10\log(P)$ dB below the transmitter power P(Watts)

$EIRP \text{ (dBm)} = S.G. \text{ Power} - Tx \text{ Cable Loss} + Tx \text{ Antenna Gain}$

$ERP \text{ (dBm)} = EIRP - 2.15$



5 List of Measuring Equipment

Instrument	Brand Name	Model No.	Serial No.	Characteristics	Calibration Date	Test Date	Due Date	Remark
Radio Communication Analyzer	Anritsu	MT8821C	6262002534 1	LTE FDD/TDD LTE-2CC ULCA/DLCA	Oct. 06, 2020	Aug. 15, 2021	Oct. 05, 2021	Conducted (TH02-HY)
Spectrum Analyzer	Rohde & Schwarz	FSV40	101397	10Hz~40GHz	Nov. 27, 2020	Aug. 15, 2021	Nov. 26, 2021	Conducted (TH02-HY)
Coupler	Warison	20dB 25W SMA Directional Coupler	#B	1-18GHz	Jan. 09, 2021	Aug. 15, 2021	Jan. 08, 2022	Conducted (TH02-HY)
Bilog Antenna	Schaffner	CBL 6111C & N-6-06	2725 & AT-N0601	30MHz~1GHz	Jan. 08, 2021	Aug. 03, 2021~ Aug. 04, 2021	Jan. 07, 2022	Radiation (03CH07-HY)
Bilog Antenna	TESEQ	CBL 6111D & 00800N1D01N -06	35419 & 03	30MHz~1GHz	Apr. 28, 2021	Aug. 03, 2021~ Aug. 04, 2021	Apr. 27, 2022	Radiation (03CH07-HY)
Double Ridge Horn Antenna	ESCO	3117	00075962	1GHz ~ 18GHz	Dec. 01, 2020	Aug. 03, 2021~ Aug. 04, 2021	Nov. 30, 2021	Radiation (03CH07-HY)
Loop Antenna	Rohde & Schwarz	HFH2-Z2	100315	9 kHz~30 MHz	Jan. 04, 2021	Aug. 03, 2021~ Aug. 04, 2021	Jan. 03, 2022	Radiation (03CH07-HY)
Preamplifier	MITEQ	AMF-7D-0010 1800-30-10P	1590075	1GHz~18GHz	Apr. 22, 2021	Aug. 03, 2021~ Aug. 04, 2021	Apr. 21, 2022	Radiation (03CH07-HY)
Preamplifier	COM-POWER	PA-103A	161241	10MHz~1GHz	May 18, 2021	Aug. 03, 2021~ Aug. 04, 2021	May 17, 2022	Radiation (03CH07-HY)
Preamplifier	Agilent	8449B	3008A02362	1GHz~26.5GHz	Oct. 31, 2020	Aug. 03, 2021~ Aug. 04, 2021	Oct. 30, 2021	Radiation (03CH07-HY)
Spectrum Analyzer	Agilent	N9030A	MY52350276	3Hz~44GHz	Jul. 22, 2021	Aug. 03, 2021~ Aug. 04, 2021	Jul. 21, 2022	Radiation (03CH07-HY)
RF Cable	HUBER + SUHNER	SUCOFLEX 104	MY15682-4	30MHz to 18GHz	Feb. 24, 2021	Aug. 03, 2021~ Aug. 04, 2021	Feb. 23, 2022	Radiation (03CH07-HY)
RF Cable	HUBER + SUHNER	SUCOFLEX 104	MY24971-4	9kHz to 18GHz	Feb. 24, 2021	Aug. 03, 2021~ Aug. 04, 2021	Feb. 23, 2022	Radiation (03CH07-HY)
RF Cable	HUBER + SUHNER	SUCOFLEX 104	MY28655-4	9kHz to 18GHz	Feb. 24, 2021	Aug. 03, 2021~ Aug. 04, 2021	Feb. 23, 2022	Radiation (03CH07-HY)
RF Cable	HUBER + SUHNER	SUCOFLEX 126	532078/126E	30MHz~18GHz	Sep. 18, 2020	Aug. 03, 2021~ Aug. 04, 2021	Sep. 17, 2021	Radiation (03CH07-HY)
Controller	EMEC	EM1000	N/A	Control Ant Mast	Apr. 28, 2021	Aug. 03, 2021~ Aug. 04, 2021	Apr. 27, 2022	Radiation (03CH07-HY)
Controller	MF	MF-7802	N/A	Control Turn table	N/A	Aug. 03, 2021~ Aug. 04, 2021	N/A	Radiation (03CH07-HY)
Antenna Mast	EMEC	AM-BS-4500E	N/A	Boresight mast 1M~4M	Apr. 28, 2021	Aug. 03, 2021~ Aug. 04, 2021	Apr. 27, 2022	Radiation (03CH07-HY)
Turn Table	ChainTek	Chaintek 3000	N/A	0~360 Degree	N/A	Aug. 03, 2021~ Aug. 04, 2021	N/A	Radiation (03CH07-HY)
Software	Audix	E3 6.2009-8-24	N/A	N/A	N/A	Aug. 03, 2021~ Aug. 04, 2021	N/A	Radiation (03CH07-HY)
Horn Antenna	EMCO	3117	00143261	1GHz~18GHz	Jan. 26, 2021	Aug. 03, 2021~ Aug. 04, 2021	Jan. 25, 2022	Radiation (03CH07-HY)
Signal Generator	Rohde & Schwarz	SMF100A	101107	100kHz~40GHz	Dec. 04, 2020	Aug. 03, 2021~ Aug. 04, 2021	Dec. 03, 2021	Radiation (03CH07-HY)



6 Uncertainty of Evaluation

Uncertainty of Radiated Emission Measurement (30 MHz ~ 1000 MHz)

Measuring Uncertainty for a Level of Confidence of 95% ($U = 2Uc(y)$)	3.16 dB
---	---------

Uncertainty of Radiated Emission Measurement (1 GHz ~ 18 GHz)

Measuring Uncertainty for a Level of Confidence of 95% ($U = 2Uc(y)$)	3.71 dB
---	---------

Uncertainty of Radiated Emission Measurement (18 GHz ~ 40 GHz)

Measuring Uncertainty for a Level of Confidence of 95% ($U = 2Uc(y)$)	4.16 dB
---	---------



Appendix A. Test Results of Conducted Test

Conducted Output Power(Average power & ERP/EIRP)

LTE Band 2 Maximum Average Power [dBm] (GT - LC = -2.7 dB)								
BW [MHz]	RB Size	RB Offset	Mod	Lowest	Middle	Highest	EIRP (dBm)	EIRP (W)
20	1	0	QPSK	22.52	22.53	22.56	20.03	0.1007
20	1	49		22.73	22.73	22.71		
20	1	99		22.29	22.36	22.31		
20	50	0		21.60	21.65	21.55		
20	50	24		21.55	21.57	21.51		
20	50	50		21.16	21.27	21.14		
20	100	0		21.40	21.46	21.39		
Limit	EIRP < 2W			Result			Pass	

LTE Band 2 Maximum Average Power [dBm] (GT - LC = -2.7 dB)								
BW [MHz]	RB Size	RB Offset	Mod	Lowest	Middle	Highest	EIRP (dBm)	EIRP (W)
15	1	0	QPSK	22.46	22.53	22.51	20.03	0.1007
15	1	37		22.73	22.73	22.65		
15	1	74		22.27	22.36	22.28		
15	36	0		21.59	21.58	21.50		
15	36	20		21.46	21.47	21.47		
15	36	39		21.12	21.23	21.06		
15	75	0		21.34	21.44	21.31		
Limit	EIRP < 2W			Result			Pass	



LTE Band 2 Maximum Average Power [dBm] (GT - LC = -2.7 dB)								
BW [MHz]	RB Size	RB Offset	Mod	Lowest	Middle	Highest	EIRP (dBm)	EIRP (W)
10	1	0	QPSK	22.42	22.46	22.50	20.02	0.1005
10	1	25		22.72	22.71	22.71		
10	1	49		22.20	22.32	22.28		
10	25	0		21.60	21.61	21.50		
10	25	12		21.51	21.49	21.50		
10	25	25		21.11	21.18	21.08		
10	50	0		21.35	21.45	21.32		
10	1	0	16-QAM	21.09	21.04	21.04	18.75	0.0750
10	1	25		21.44	21.45	21.38		
10	1	49		21.08	21.03	21.08		
10	25	0		19.67	19.50	19.71		
10	25	12		19.98	19.47	19.68		
10	25	25		19.91	19.46	19.58		
Limit	EIRP < 2W			Result			Pass	

LTE Band 2 Maximum Average Power [dBm] (GT - LC = -2.7 dB)								
BW [MHz]	RB Size	RB Offset	Mod	Lowest	Middle	Highest	EIRP (dBm)	EIRP (W)
5	1	0	QPSK	22.45	22.46	22.55	20.03	0.1007
5	1	12		22.71	22.73	22.68		
5	1	24		22.20	22.32	22.26		
5	12	0		21.56	21.63	21.47		
5	12	7		21.46	21.56	21.43		
5	12	13		21.08	21.27	21.07		
5	25	0		21.39	21.45	21.36		
5	1	0	16-QAM	21.09	21.07	21.08	18.76	0.0752
5	1	12		21.45	21.41	21.46		
5	1	24		21.04	21.12	21.07		
5	12	0		19.66	19.48	19.64		
5	12	7		19.95	19.39	19.66		
5	12	13		19.88	19.48	19.61		
5	25	0		20.00	19.52	19.83		
Limit	EIRP < 2W			Result			Pass	



LTE Band 2 Maximum Average Power [dBm] (GT - LC = -2.7 dB)								
BW [MHz]	RB Size	RB Offset	Mod	Lowest	Middle	Highest	EIRP (dBm)	EIRP (W)
3	1	0	QPSK	22.45	22.48	22.47	20.02	0.1005
3	1	8		22.69	22.72	22.71		
3	1	14		22.24	22.27	22.28		
3	8	0		21.56	21.55	21.49		
3	8	4		21.50	21.50	21.44		
3	8	7		21.11	21.27	21.14		
3	15	0		21.40	21.37	21.39		
3	1	0	16-QAM	21.14	21.07	21.11	18.76	0.0752
3	1	8		21.44	21.43	21.46		
3	1	14		21.13	21.09	21.06		
3	8	0		19.65	19.47	19.64		
3	8	4		20.00	19.41	19.71		
3	8	7		19.82	19.47	19.58		
3	15	0		19.93	19.52	19.80		
Limit	EIRP < 2W			Result			Pass	

LTE Band 2 Maximum Average Power [dBm] (GT - LC = -2.7 dB)								
BW [MHz]	RB Size	RB Offset	Mod	Lowest	Middle	Highest	EIRP (dBm)	EIRP (W)
1.4	1	0	QPSK	22.43	22.53	22.48	20.03	0.1007
1.4	1	3		22.73	22.72	22.71		
1.4	1	5		22.25	22.34	22.24		
1.4	3	0		22.47	22.43	22.56		
1.4	3	1		22.68	22.71	22.70		
1.4	3	3		22.26	22.30	22.30		
1.4	6	0		21.52	21.59	21.52		
1.4	1	0	16-QAM	21.09	21.05	21.08	18.76	0.0752
1.4	1	3		21.45	21.39	21.46		
1.4	1	5		21.09	21.12	21.04		
1.4	3	0		21.07	21.09	21.06		
1.4	3	1		21.46	21.41	21.41		
1.4	3	3		21.06	21.08	21.07		
1.4	6	0		19.66	19.49	19.65		
Limit	EIRP < 2W			Result			Pass	



LTE Band 4 Maximum Average Power [dBm] (GT - LC = -5.3 dB)								
BW [MHz]	RB Size	RB Offset	Mod	Lowest	Middle	Highest	EIRP (dBm)	EIRP (W)
20	1	0	QPSK	22.04	22.40	22.71	17.41	0.0551
20	1	49		22.16	22.42	22.40		
20	1	99		22.07	22.49	22.50		
20	50	0		21.11	21.55	21.35		
20	50	24		21.19	21.47	21.55		
20	50	50		21.14	21.45	21.51		
20	100	0		21.16	21.62	21.40		
Limit	EIRP < 1W			Result			Pass	

LTE Band 4 Maximum Average Power [dBm] (GT - LC = -5.3 dB)								
BW [MHz]	RB Size	RB Offset	Mod	Lowest	Middle	Highest	EIRP (dBm)	EIRP (W)
15	1	0	QPSK	21.96	22.38	22.71	17.41	0.0551
15	1	37		22.12	22.35	22.32		
15	1	74		22.06	22.49	22.47		
15	36	0		21.05	21.47	21.27		
15	36	20		21.10	21.42	21.55		
15	36	39		21.09	21.36	21.44		
15	75	0		21.13	21.58	21.34		
Limit	EIRP < 1W			Result			Pass	



LTE Band 4 Maximum Average Power [dBm] (GT - LC = -5.3 dB)								
BW [MHz]	RB Size	RB Offset	Mod	Lowest	Middle	Highest	EIRP (dBm)	EIRP (W)
10	1	0	QPSK	22.03	22.34	22.70	17.40	0.0550
10	1	25		22.08	22.34	22.38		
10	1	49		22.01	22.47	22.48		
10	25	0		21.11	21.51	21.30		
10	25	12		21.10	21.42	21.46		
10	25	25		21.05	21.35	21.42		
10	50	0		21.13	21.58	21.32		
10	1	0	16-QAM	21.26	21.06	21.38	16.08	0.0406
10	1	25		21.07	21.19	21.13		
10	1	49		21.13	21.26	21.35		
10	25	0		20.32	20.64	20.51		
10	25	12		20.44	20.55	20.50		
10	25	25		20.42	20.55	20.59		
Limit	EIRP < 1W			Result			Pass	

LTE Band 4 Maximum Average Power [dBm] (GT - LC = -5.3 dB)								
BW [MHz]	RB Size	RB Offset	Mod	Lowest	Middle	Highest	EIRP (dBm)	EIRP (W)
5	1	0	QPSK	21.96	22.39	22.71	17.41	0.0551
5	1	12		22.06	22.41	22.33		
5	1	24		22.02	22.41	22.47		
5	12	0		21.06	21.45	21.33		
5	12	7		21.14	21.47	21.51		
5	12	13		21.04	21.45	21.46		
5	25	0		21.09	21.57	21.38		
5	1	0	16-QAM	21.27	21.10	21.34	16.04	0.0402
5	1	12		21.05	21.28	21.21		
5	1	24		21.16	21.30	21.34		
5	12	0		20.37	20.64	20.53		
5	12	7		20.40	20.54	20.48		
5	12	13		20.40	20.59	20.58		
5	25	0		20.32	20.67	20.41		
Limit	EIRP < 1W			Result			Pass	



LTE Band 4 Maximum Average Power [dBm] (GT - LC = -5.3 dB)								
BW [MHz]	RB Size	RB Offset	Mod	Lowest	Middle	Highest	EIRP (dBm)	EIRP (W)
3	1	0	QPSK	22.01	22.32	22.70	17.40	0.0550
3	1	8		22.12	22.32	22.31		
3	1	14		22.04	22.49	22.49		
3	8	0		21.06	21.45	21.35		
3	8	4		21.10	21.41	21.50		
3	8	7		21.10	21.39	21.45		
3	15	0		21.13	21.53	21.34		
3	1	0	16-QAM	21.20	21.07	21.31	16.01	0.0399
3	1	8		21.10	21.18	21.14		
3	1	14		21.18	21.29	21.25		
3	8	0		20.36	20.62	20.46		
3	8	4		20.44	20.53	20.55		
3	8	7		20.33	20.54	20.55		
3	15	0		20.27	20.62	20.37		
Limit	EIRP < 1W			Result			Pass	

LTE Band 4 Maximum Average Power [dBm] (GT - LC = -5.3 dB)								
BW [MHz]	RB Size	RB Offset	Mod	Lowest	Middle	Highest	EIRP (dBm)	EIRP (W)
1.4	1	0	QPSK	22.02	22.37	22.71	17.41	0.0551
1.4	1	3		22.10	22.40	22.30		
1.4	1	5		22.03	22.47	22.46		
1.4	3	0		21.98	22.40	22.71		
1.4	3	1		22.07	22.33	22.34		
1.4	3	3		22.04	22.49	22.43		
1.4	6	0		21.05	21.55	21.31		
1.4	1	0	16-QAM	21.23	21.08	21.40	16.10	0.0407
1.4	1	3		21.10	21.23	21.18		
1.4	1	5		21.19	21.30	21.29		
1.4	3	0		21.17	21.11	21.30		
1.4	3	1		21.12	21.21	21.20		
1.4	3	3		21.19	21.24	21.34		
1.4	6	0		20.33	20.63	20.52		
Limit	EIRP < 1W			Result			Pass	



LTE Band 5 Maximum Average Power [dBm] (GT - LC = -5.4 dB)								
BW [MHz]	RB Size	RB Offset	Mod	Lowest	Middle	Highest	ERP (dBm)	ERP (W)
10	1	0	QPSK	22.10	22.73	22.73	15.18	0.0330
10	1	25		22.37	22.70	22.69		
10	1	49		22.31	22.73	22.73		
10	25	0		21.50	21.84	21.92		
10	25	12		21.33	21.58	22.73		
10	25	25		21.47	21.66	21.89		
10	50	0		21.45	21.82	22.01		
10	1	0	16-QAM	21.41	21.80	21.92	14.44	0.0278
10	1	25		21.44	21.64	21.92		
10	1	49		21.50	21.79	21.99		
10	25	0		20.46	20.84	20.96		
10	25	12		20.45	20.91	20.94		
10	25	25		20.37	20.78	21.03		
Limit	ERP < 7W			Result			Pass	

LTE Band 5 Maximum Average Power [dBm] (GT - LC = -5.4 dB)								
BW [MHz]	RB Size	RB Offset	Mod	Lowest	Middle	Highest	ERP (dBm)	ERP (W)
5	1	0	QPSK	22.07	22.73	22.73	15.18	0.0330
5	1	12		22.36	22.60	22.60		
5	1	24		22.25	22.73	22.71		
5	12	0		21.43	21.84	21.84		
5	12	7		21.25	21.56	22.73		
5	12	13		21.38	21.66	21.82		
5	25	0		21.44	21.75	22.00		
5	1	0	16-QAM	21.39	21.78	21.86	14.34	0.0272
5	1	12		21.43	21.64	21.83		
5	1	24		21.50	21.77	21.89		
5	12	0		20.43	20.77	20.87		
5	12	7		20.45	20.90	20.87		
5	12	13		20.33	20.71	20.95		
5	25	0		20.28	20.64	20.41		
Limit	ERP < 7W			Result			Pass	



LTE Band 5 Maximum Average Power [dBm] (GT - LC = -5.4 dB)								
BW [MHz]	RB Size	RB Offset	Mod	Lowest	Middle	Highest	ERP (dBm)	ERP (W)
3	1	0	QPSK	22.06	22.73	22.73	15.18	0.0330
3	1	8		22.27	22.68	22.65		
3	1	14		22.27	22.73	22.73		
3	8	0		21.49	21.76	21.82		
3	8	4		21.33	21.56	22.73		
3	8	7		21.45	21.57	21.87		
3	15	0		21.41	21.77	21.95		
3	1	0	16-QAM	21.35	21.71	21.90	14.37	0.0274
3	1	8		21.41	21.61	21.92		
3	1	14		21.47	21.78	21.91		
3	8	0		20.38	20.81	20.89		
3	8	4		20.44	20.82	20.84		
3	8	7		20.35	20.72	21.02		
3	15	0		20.27	20.67	20.35		
Limit	ERP < 7W			Result			Pass	

LTE Band 5 Maximum Average Power [dBm] (GT - LC = -5.4 dB)								
BW [MHz]	RB Size	RB Offset	Mod	Lowest	Middle	Highest	ERP (dBm)	ERP (W)
1.4	1	0	QPSK	22.04	22.73	22.73	15.18	0.0330
1.4	1	3		22.29	22.60	22.67		
1.4	1	5		22.27	22.73	22.71		
1.4	3	0		22.06	22.73	22.73		
1.4	3	1		22.27	22.62	22.65		
1.4	3	3		22.27	22.73	22.73		
1.4	6	0		21.46	21.80	21.90		
1.4	1	0	16-QAM	21.32	21.76	21.84	14.42	0.0277
1.4	1	3		21.40	21.58	21.92		
1.4	1	5		21.50	21.72	21.97		
1.4	3	0		21.33	21.79	21.88		
1.4	3	1		21.44	21.58	21.90		
1.4	3	3		21.46	21.73	21.95		
1.4	6	0		20.44	20.83	20.88		
Limit	ERP < 7W			Result			Pass	



LTE Band 13 Maximum Average Power [dBm] (GT - LC = -7.9 dB)								
BW [MHz]	RB Size	RB Offset	Mod	Lowest	Middle	Highest	ERP (dBm)	ERP (W)
10	1	0	QPSK	-	22.51	-	12.46	0.0176
10	1	25			22.34			
10	1	49			22.20			
10	25	0			21.71			
10	25	12			21.61			
10	25	25			21.52			
10	50	0			21.62			
10	1	0	16-QAM		21.62		11.57	0.0144
10	1	25			21.59			
10	1	49			21.43			
10	25	0			20.71			
10	25	12			20.64			
10	25	25			20.61			
Limit	ERP < 3W				Result			

LTE Band 13 Maximum Average Power [dBm] (GT - LC = -7.9 dB)								
BW [MHz]	RB Size	RB Offset	Mod	Lowest	Middle	Highest	ERP (dBm)	ERP (W)
5	1	0	QPSK	22.16	22.50	22.28	12.46	0.0176
5	1	12		22.51	22.48	22.50		
5	1	24		22.38	22.50	22.29		
5	12	0		21.67	21.66	21.82		
5	12	7		21.62	21.80	21.79		
5	12	13		21.64	21.78	21.81		
5	25	0		21.71	21.75	21.76		
5	1	0	16-QAM	21.38	21.94	21.60	11.89	0.0155
5	1	12		21.79	21.35	21.68		
5	1	24		21.53	21.58	21.66		
5	12	0		20.51	20.69	20.85		
5	12	7		20.68	20.56	20.83		
5	12	13		20.64	20.64	20.78		
5	25	0		20.55	20.62	20.95		
Limit	ERP < 3W			Result			Pass	



LTE Band 2

Conducted Band Edge

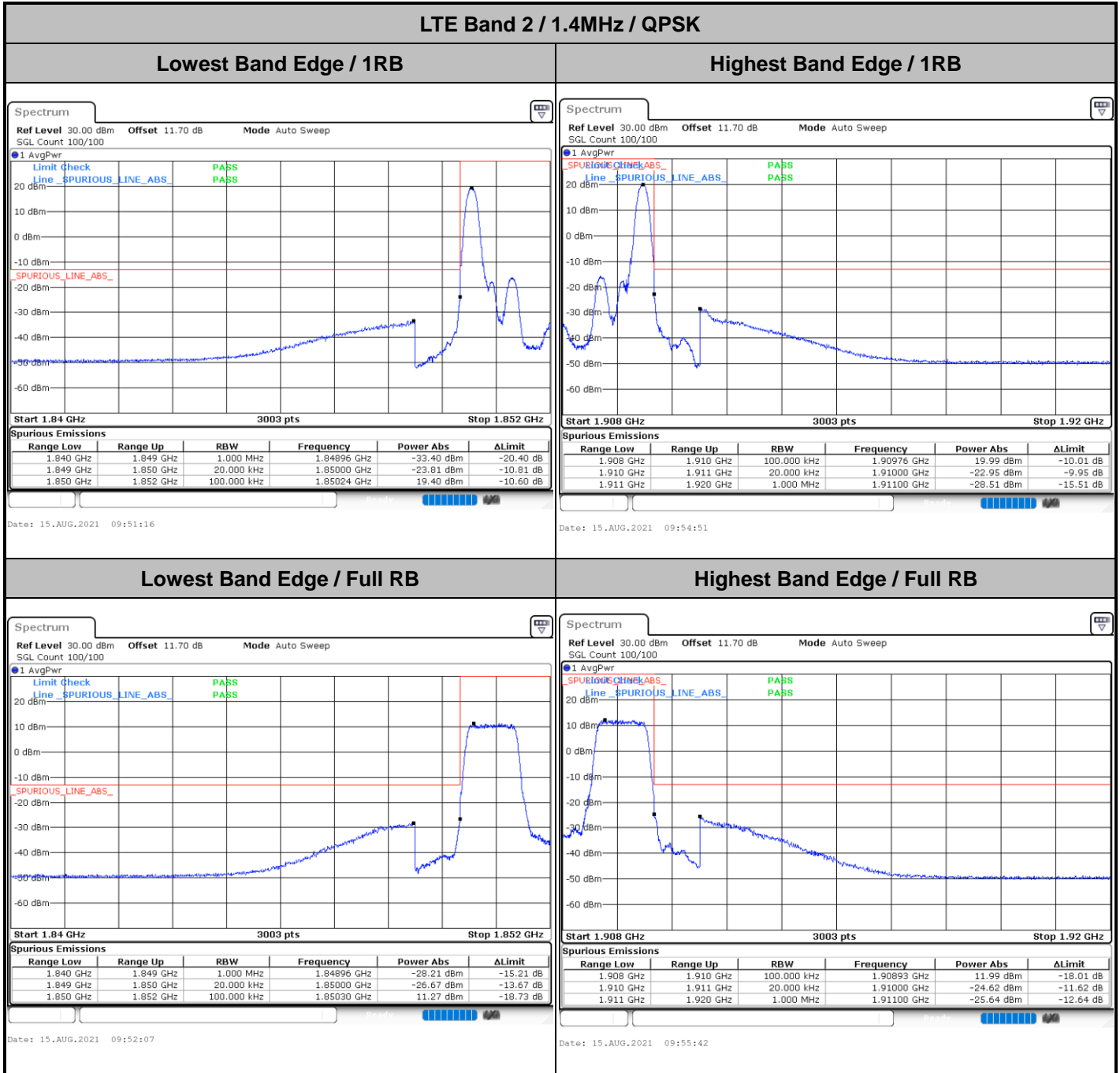



LTE Band 2 / 1.4MHz / 16QAM

Lowest Band Edge / 1 RB

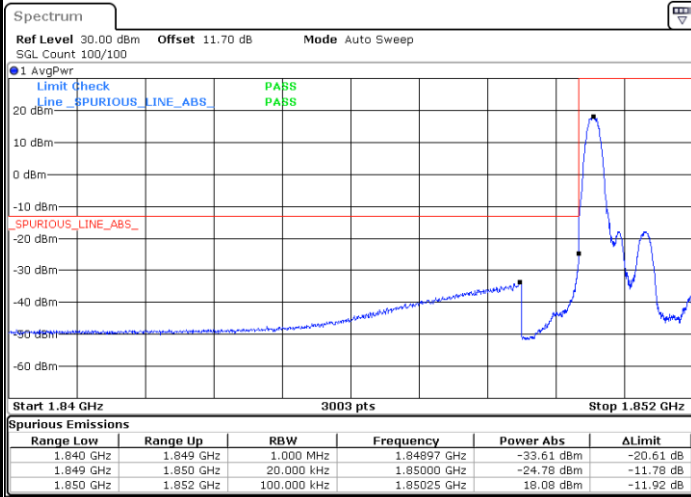

Date: 15.AUG.2021 09:51:41

Highest Band Edge / 1 RB

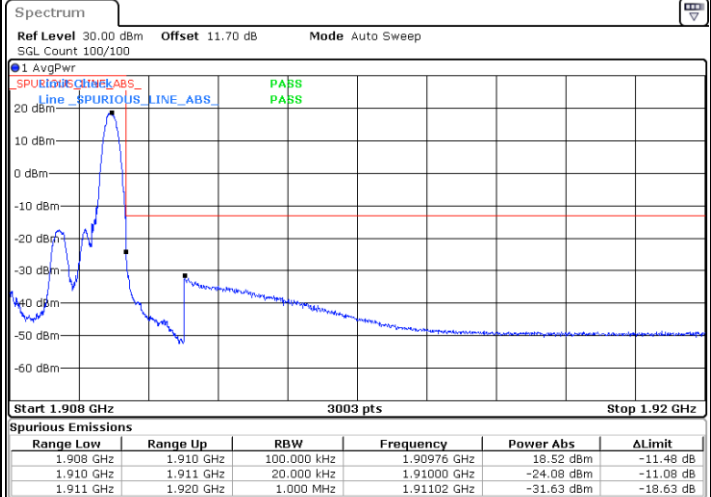

Date: 15.AUG.2021 09:55:16

Lowest Band Edge / Full RB

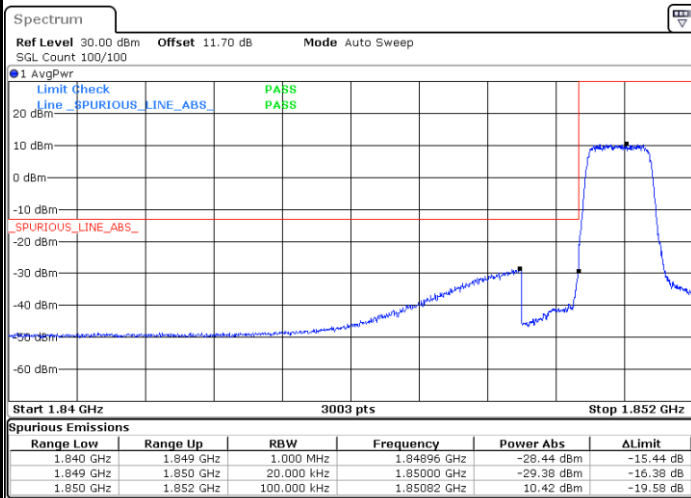

Date: 15.AUG.2021 09:52:33

Highest Band Edge / Full RB

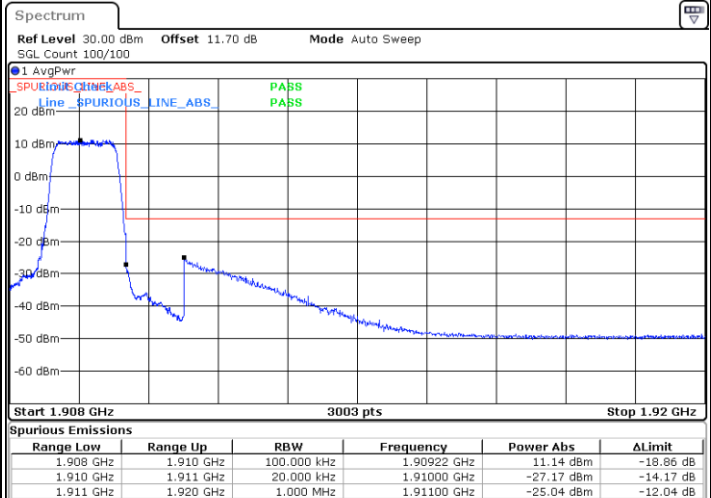

Date: 15.AUG.2021 09:56:08



LTE Band 2 / 3MHz / QPSK

Lowest Band Edge / 1RB

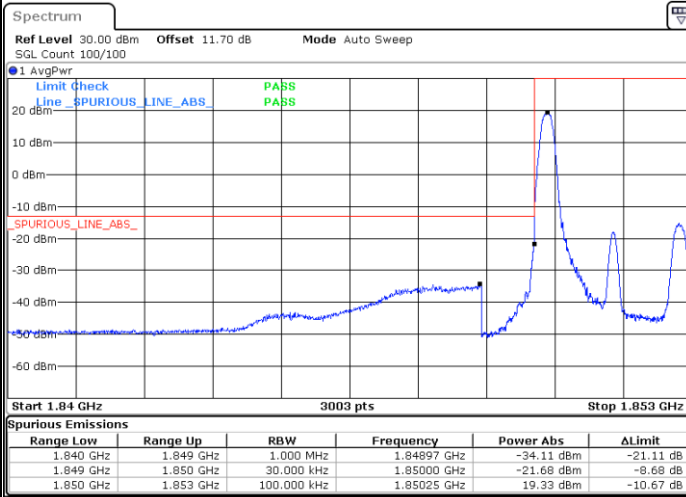

Date: 15.AUG.2021 09:57:31

Highest Band Edge / 1 RB

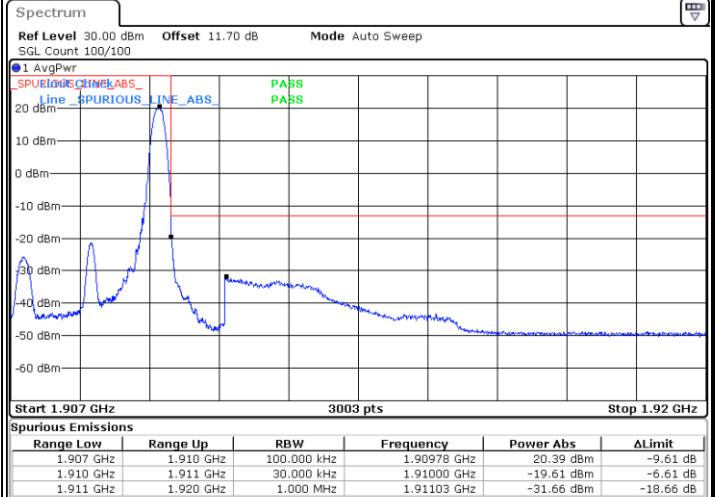

Date: 15.AUG.2021 10:01:06

Lowest Band Edge / Full RB

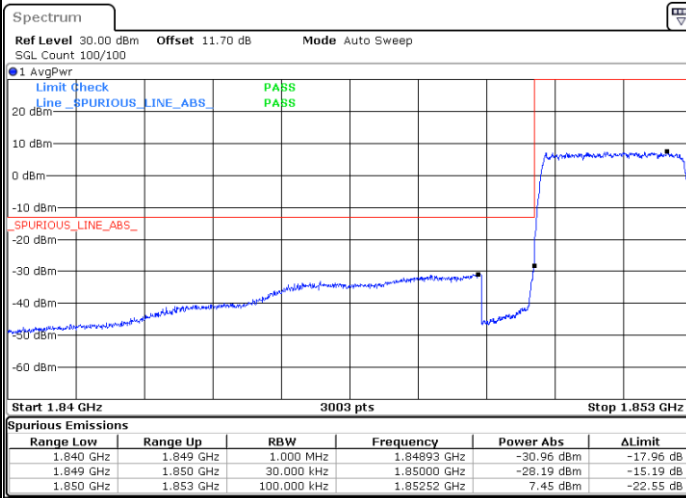

Date: 15.AUG.2021 09:58:23

Highest Band Edge / Full RB



Date: 15.AUG.2021 10:01:58



LTE Band 2 / 3MHz / 16QAM

Lowest Band Edge / 1 RB

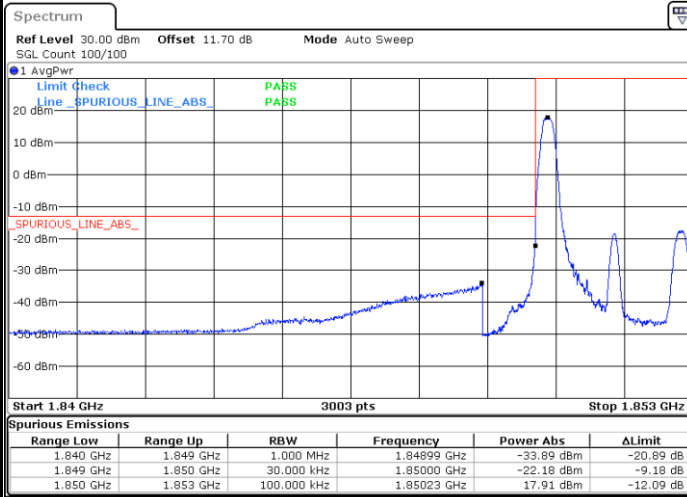

Date: 15.AUG.2021 09:57:57

Highest Band Edge / 1 RB

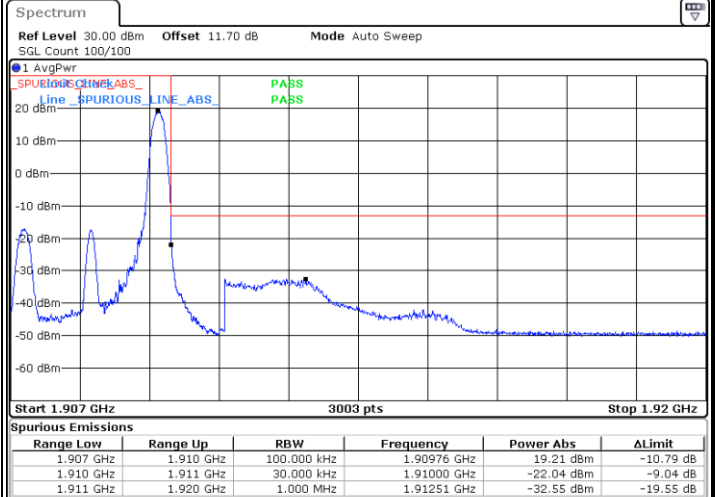

Date: 15.AUG.2021 10:01:32

Lowest Band Edge / Full RB

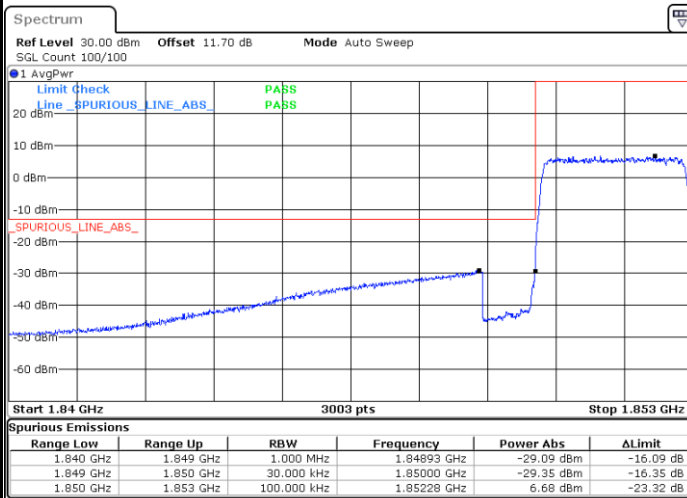

Date: 15.AUG.2021 09:58:48

Highest Band Edge / Full RB

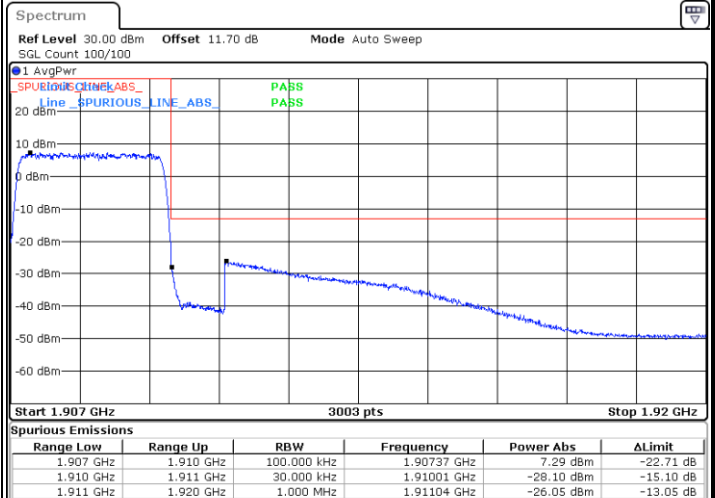

Date: 15.AUG.2021 10:02:24



LTE Band 2 / 5MHz / QPSK

Lowest Band Edge / 1 RB

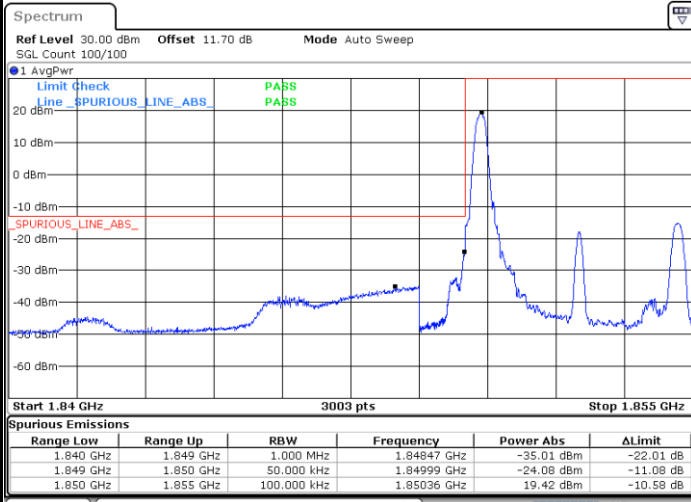

Date: 15.AUG.2021 10:03:47

Highest Band Edge / 1 RB

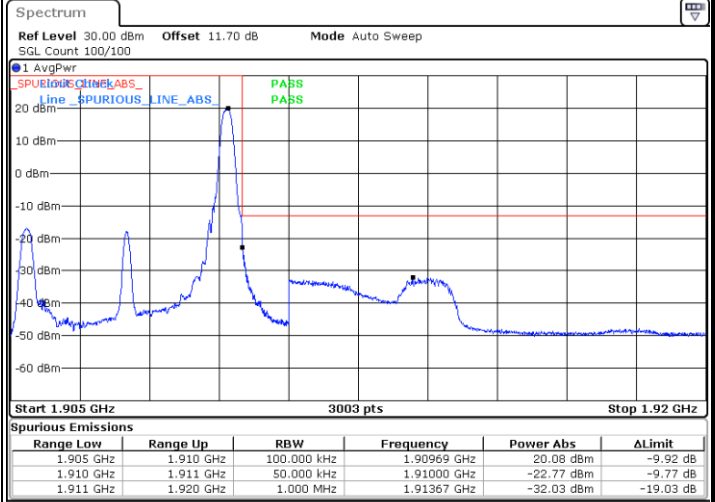

Date: 15.AUG.2021 10:07:21

Lowest Band Edge / Full RB

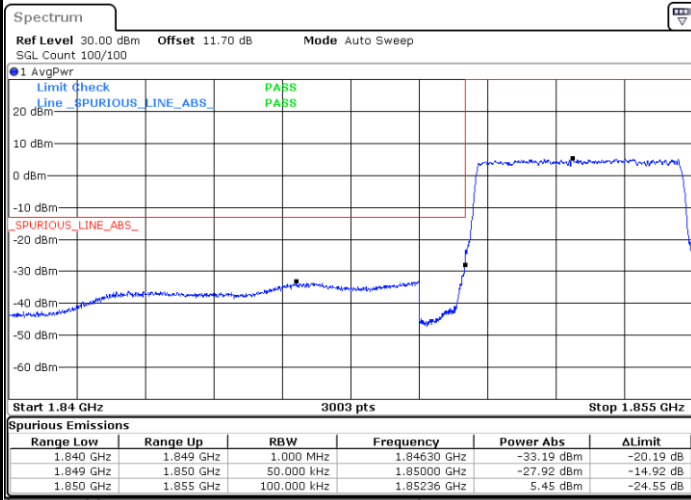

Date: 15.AUG.2021 10:04:39

Highest Band Edge / Full RB

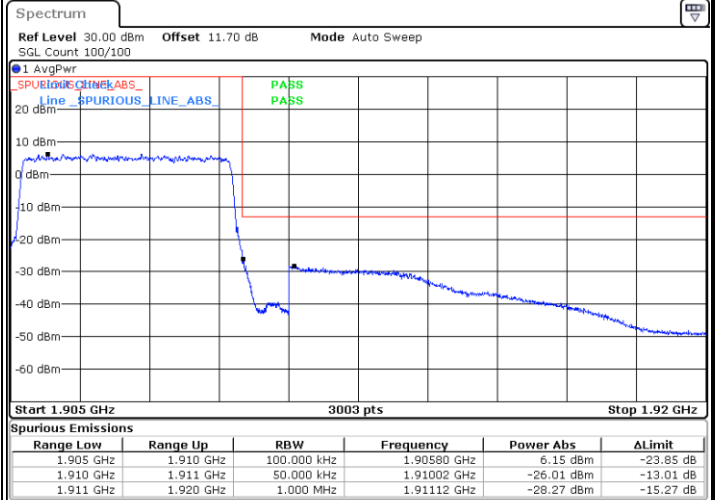

Date: 15.AUG.2021 10:08:13



LTE Band 2 / 5MHz / 16QAM

Lowest Band Edge / 1RB

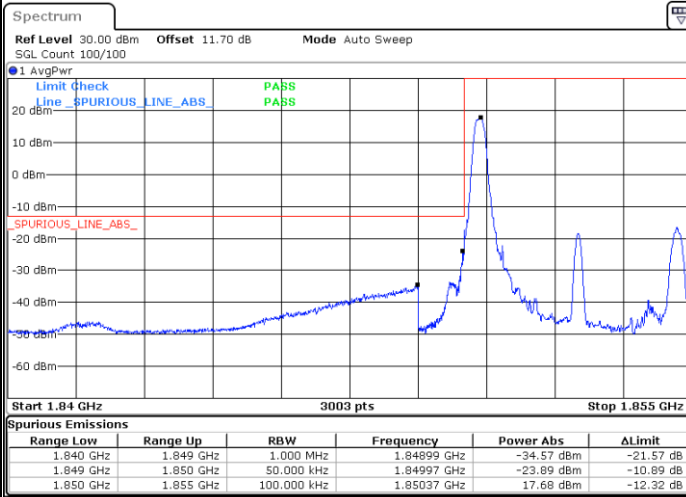

Date: 15.AUG.2021 10:04:13

Highest Band Edge / 1 RB

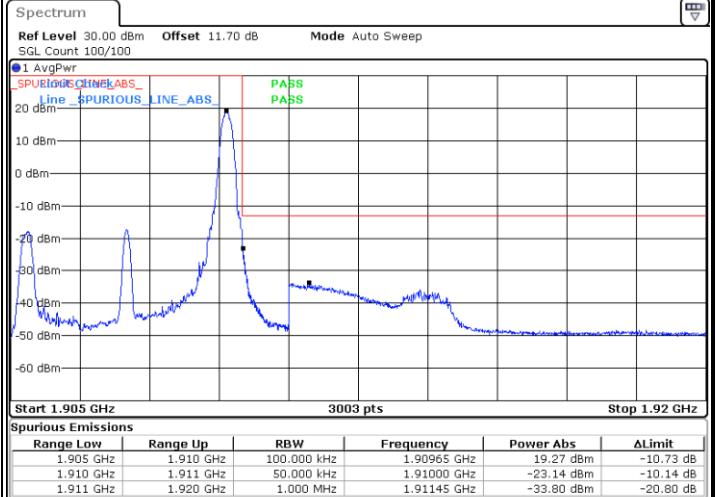

Date: 15.AUG.2021 10:07:47

Lowest Band Edge / Full RB

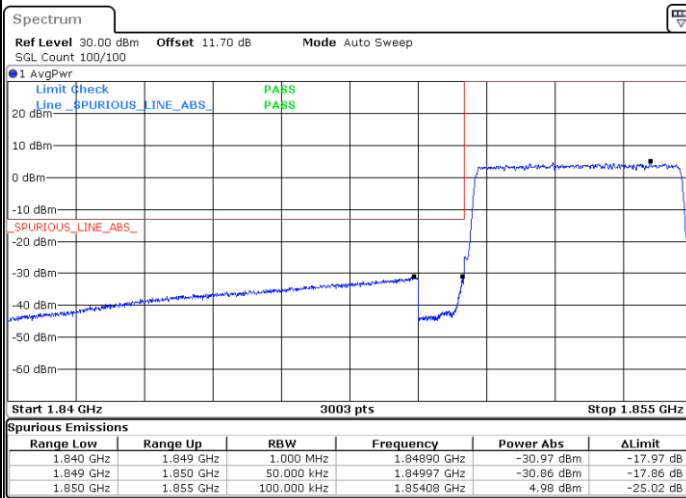

Date: 15.AUG.2021 10:05:05

Highest Band Edge / Full RB

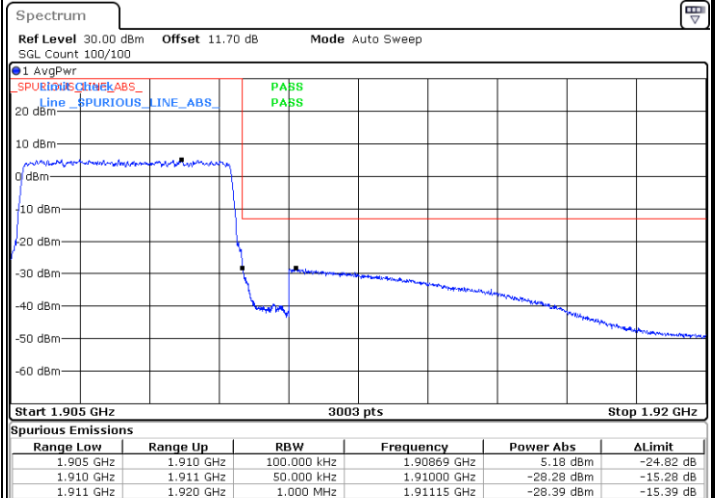

Date: 15.AUG.2021 10:08:39



LTE Band 2 / 10MHz / QPSK

Lowest Band Edge / 1 RB

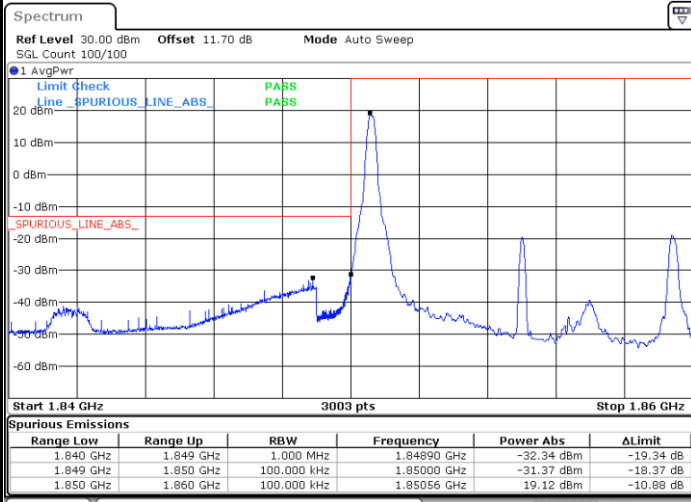

Date: 15.AUG.2021 10:10:02

Highest Band Edge / 1 RB

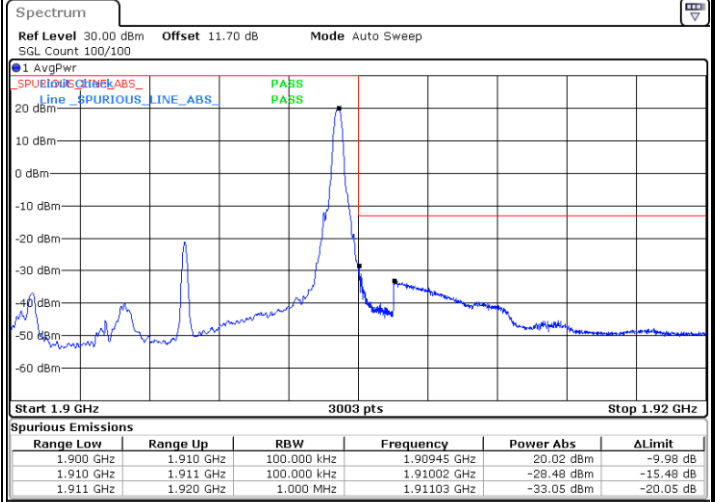

Date: 15.AUG.2021 10:13:12

Lowest Band Edge / Full RB

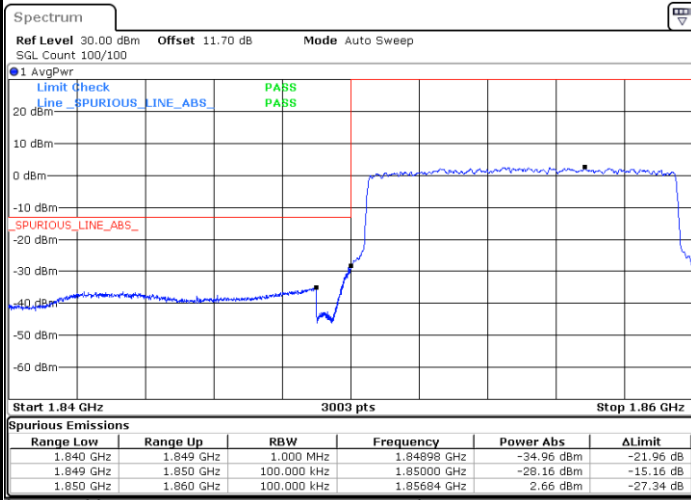

Date: 15.AUG.2021 10:10:54

Highest Band Edge / Full RB

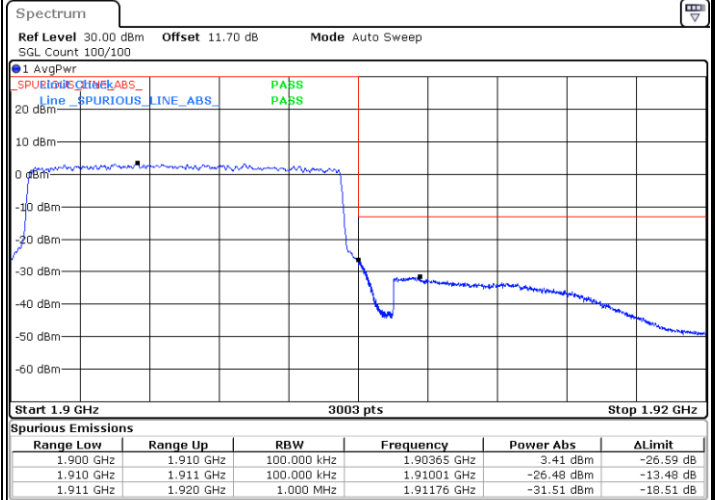

Date: 15.AUG.2021 10:14:04



LTE Band 2 / 10MHz / 16QAM

Lowest Band Edge / 1 RB

Highest Band Edge / 1 RB

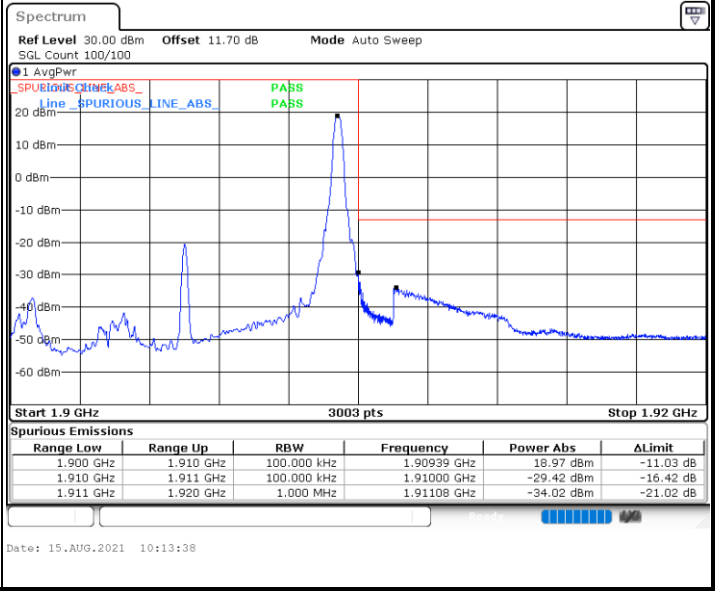
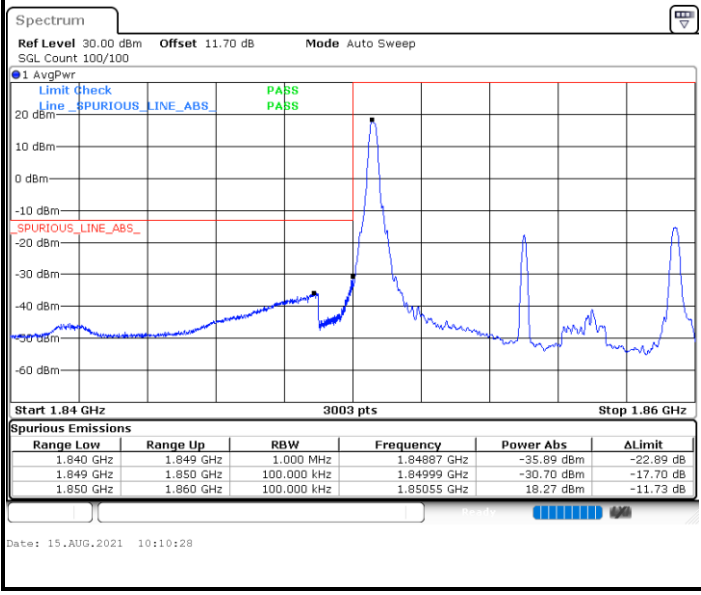



LTE Band 2 / 15MHz / QPSK

Lowest Band Edge / 1 RB

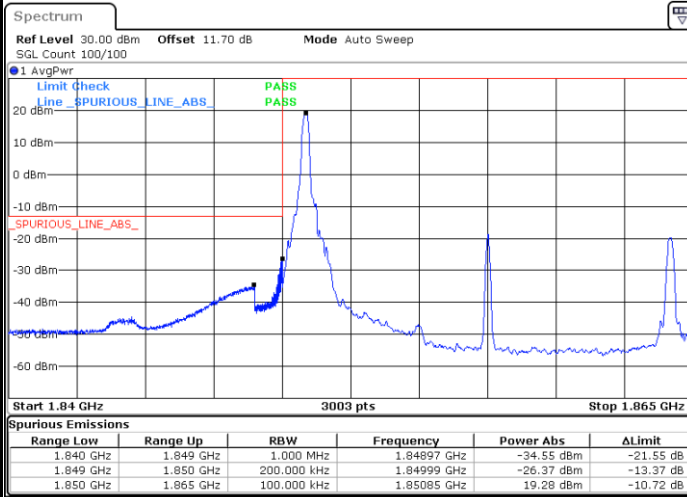

Date: 15.AUG.2021 10:15:27

Highest Band Edge / 1 RB

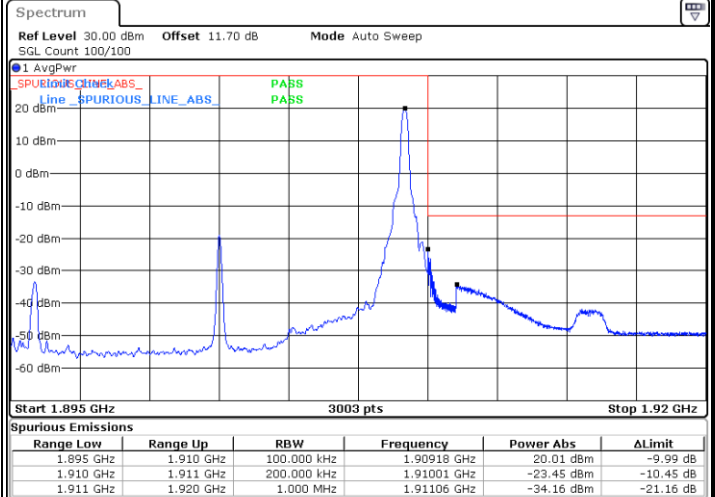

Date: 15.AUG.2021 10:18:35

Lowest Band Edge / Full RB

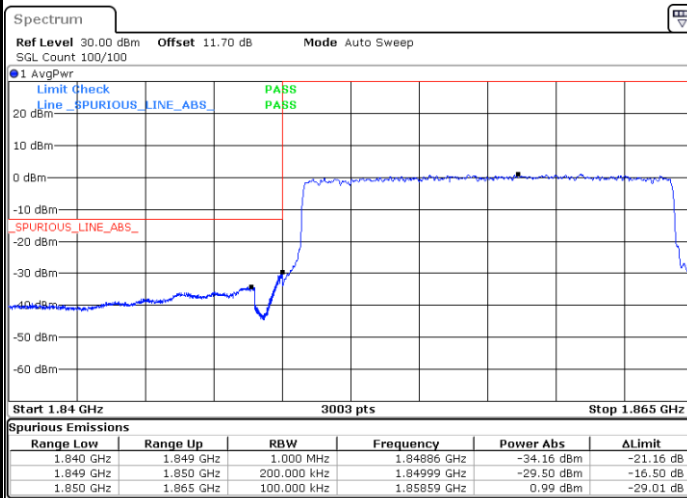

Date: 15.AUG.2021 10:16:19

Highest Band Edge / Full RB

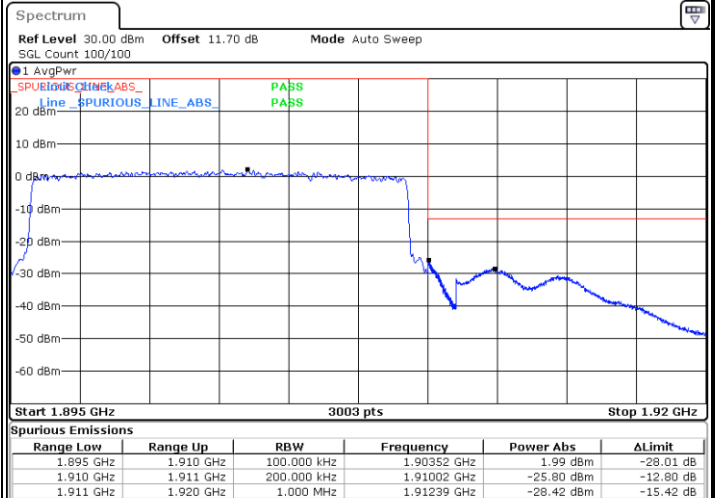

Date: 15.AUG.2021 10:19:27



LTE Band 2 / 15MHz / 16QAM

Lowest Band Edge / 1 RB

Highest Band Edge / 1 RB

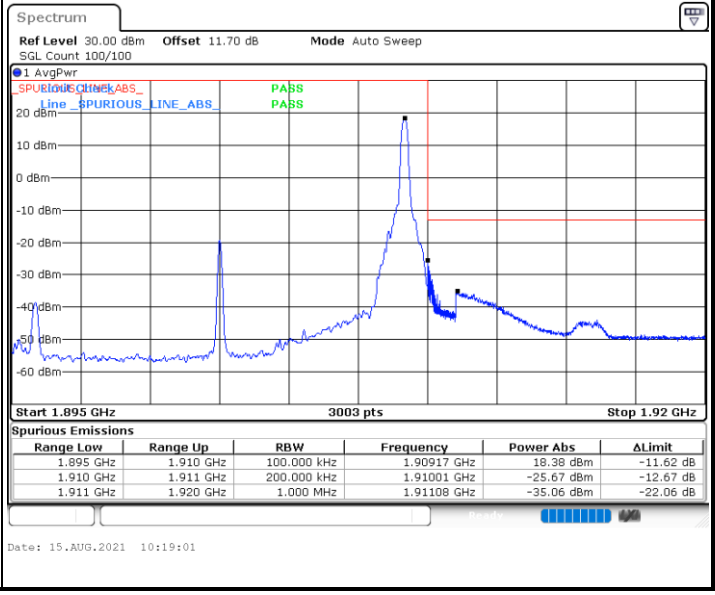
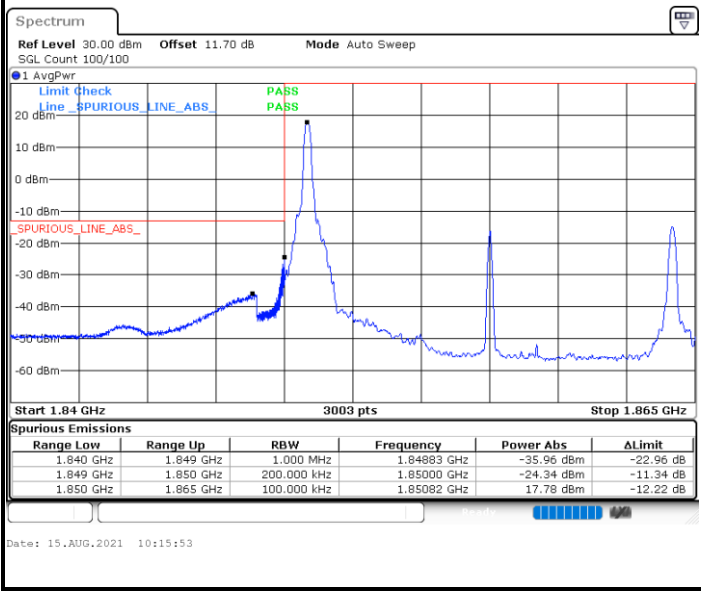



LTE Band 2 / 20MHz / QPSK

Lowest Band Edge / 1 RB

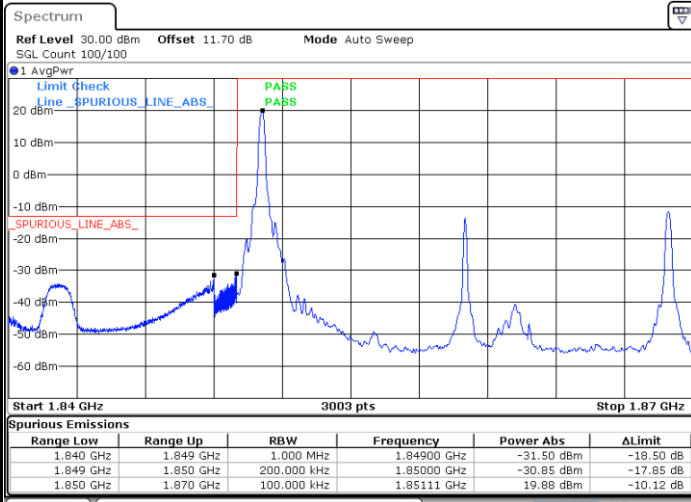

Date: 15.AUG.2021 10:20:51

Highest Band Edge / 1 RB

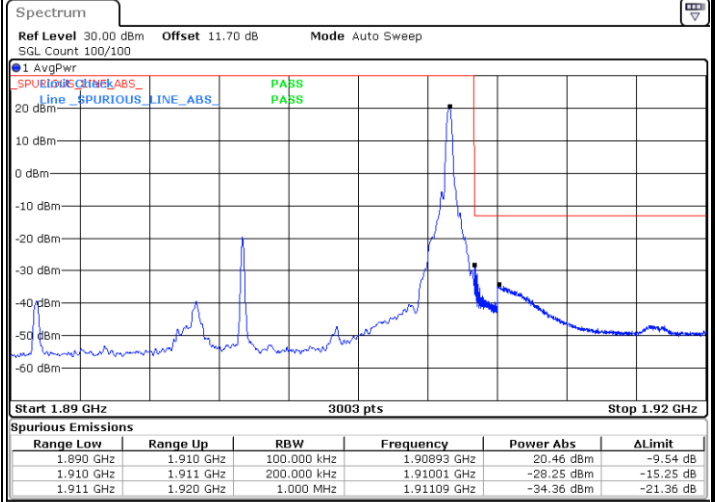

Date: 15.AUG.2021 10:24:36

Lowest Band Edge / Full RB

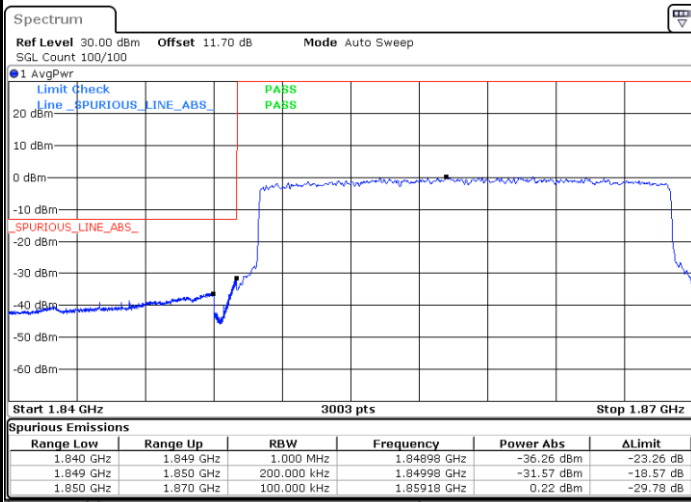

Date: 15.AUG.2021 10:21:42

Highest Band Edge / Full RB

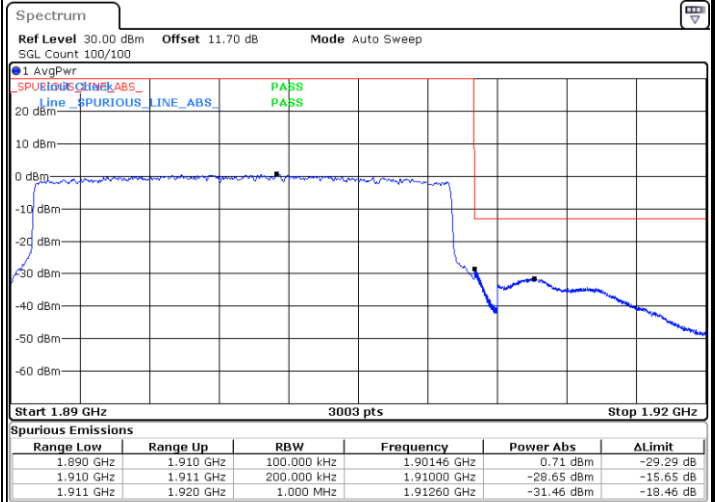

Date: 15.AUG.2021 10:25:27



LTE Band 2 / 20MHz / 16QAM

Lowest Band Edge / 1 RB

Highest Band Edge / 1 RB

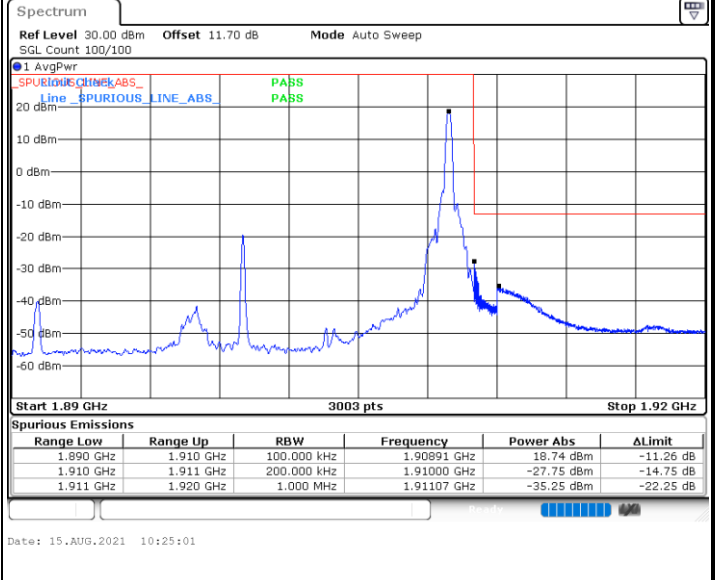
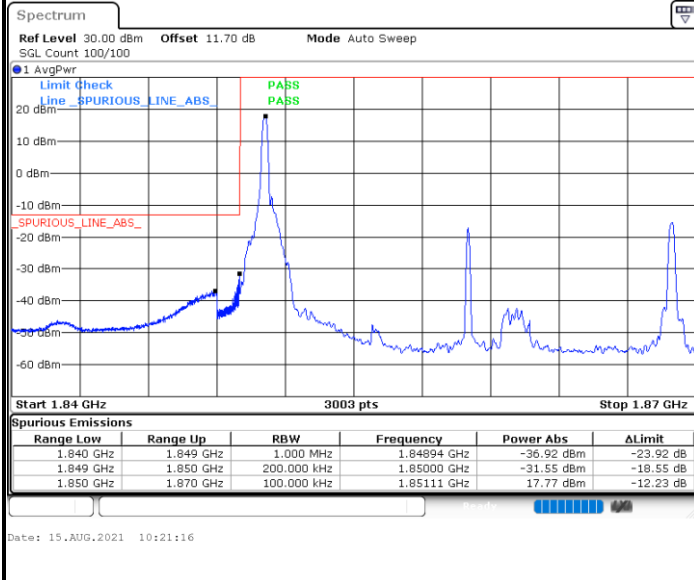



Conducted Spurious Emission

LTE Band 2 / 1.4MHz

Lowest Channel / QPSK

Middle Channel / QPSK

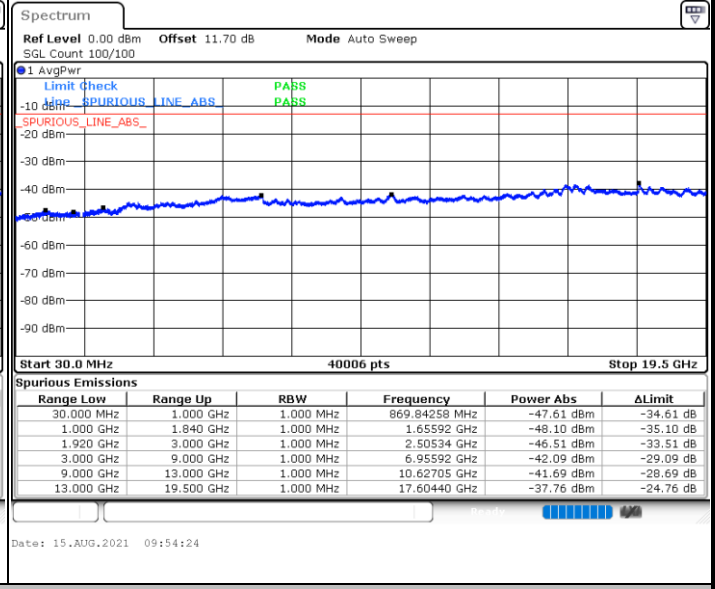
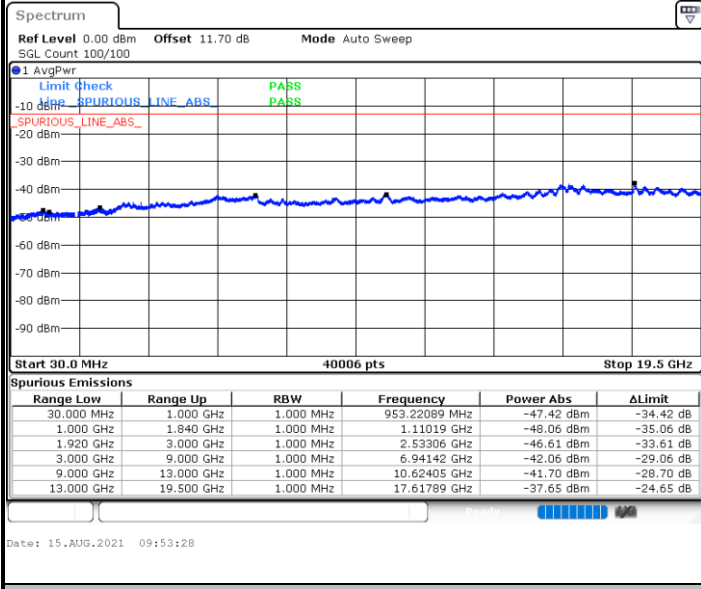

Highest Channel / QPSK

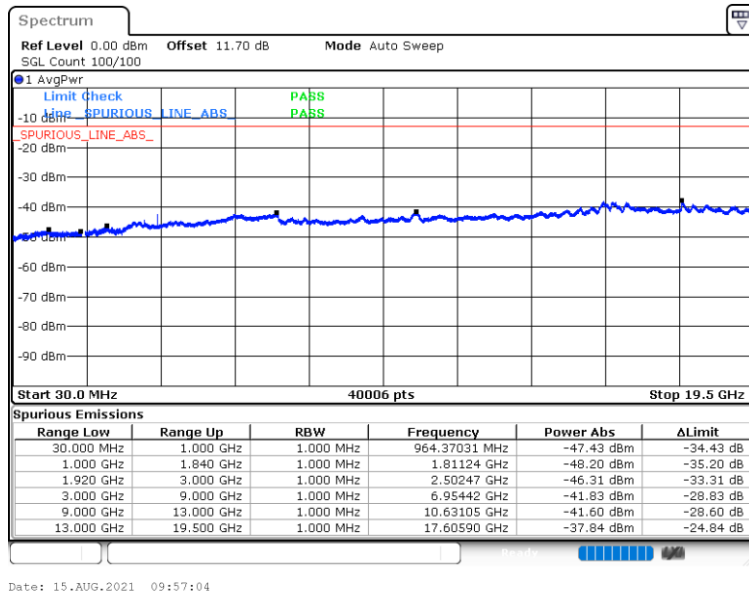



LTE Band 2 / 3MHz

Lowest Channel / QPSK

Middle Channel / QPSK

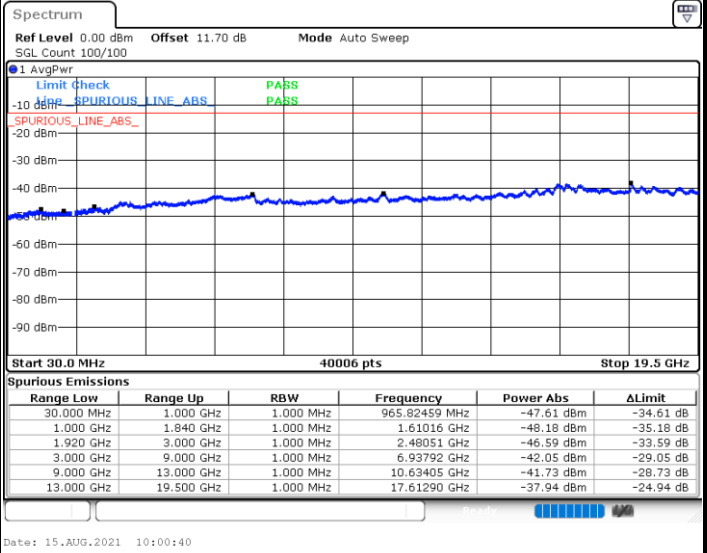
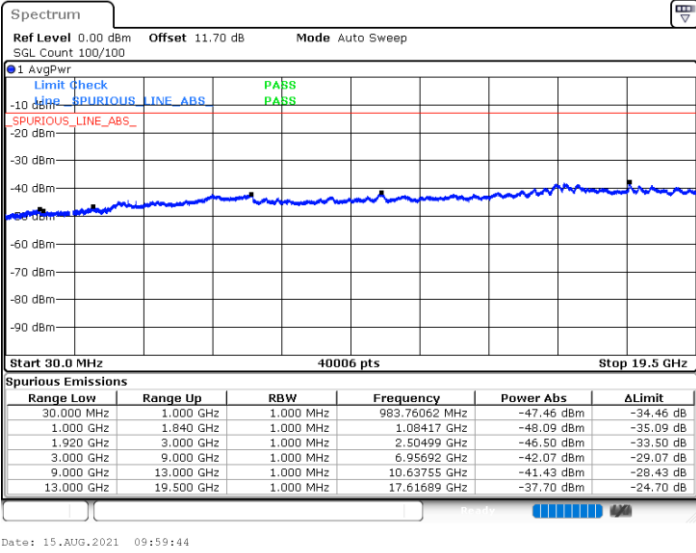

Highest Channel / QPSK

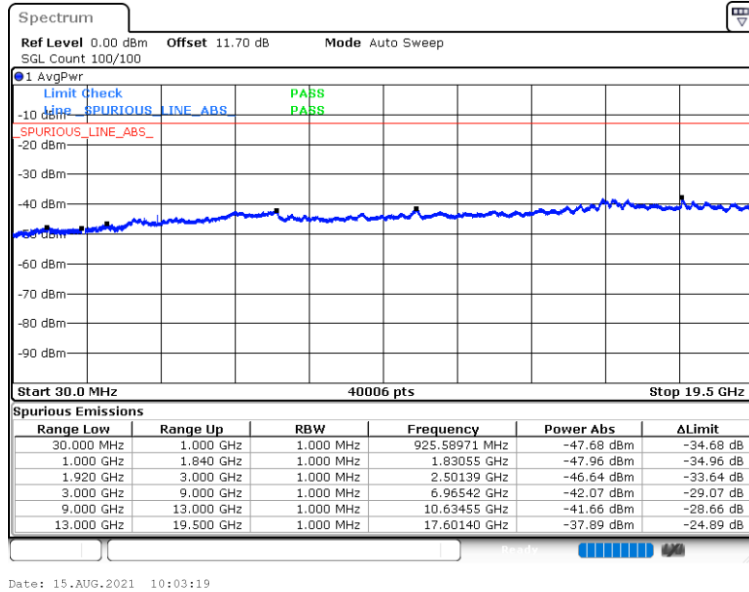



LTE Band 2 / 5MHz

Lowest Channel / QPSK

Middle Channel / QPSK

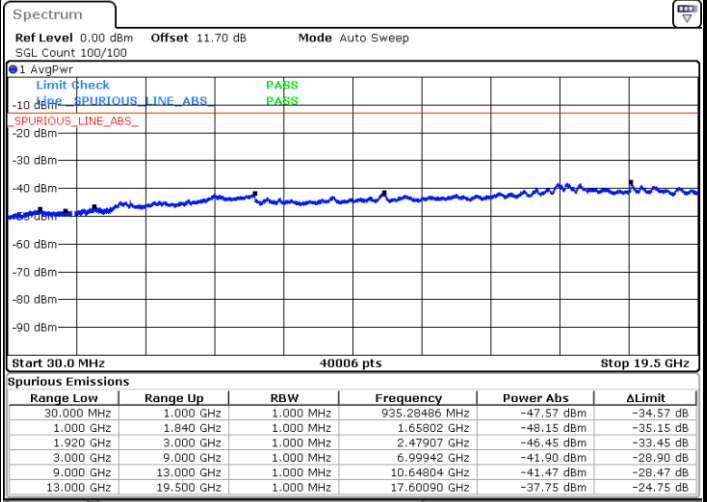
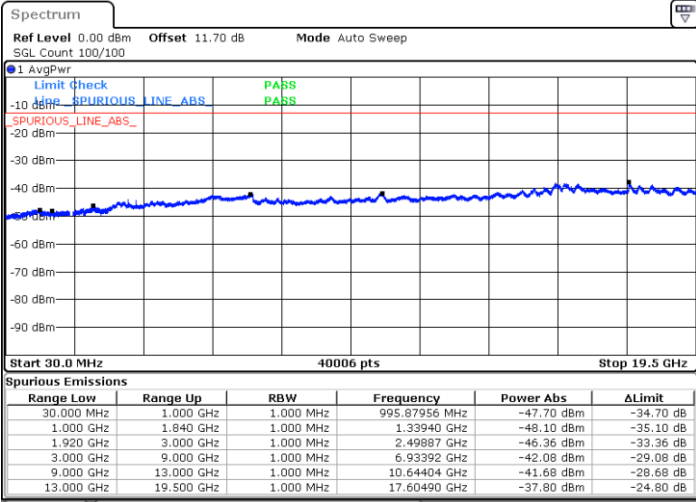

Date: 15.AUG.2021 10:06:00

Date: 15.AUG.2021 10:06:56

Highest Channel / QPSK

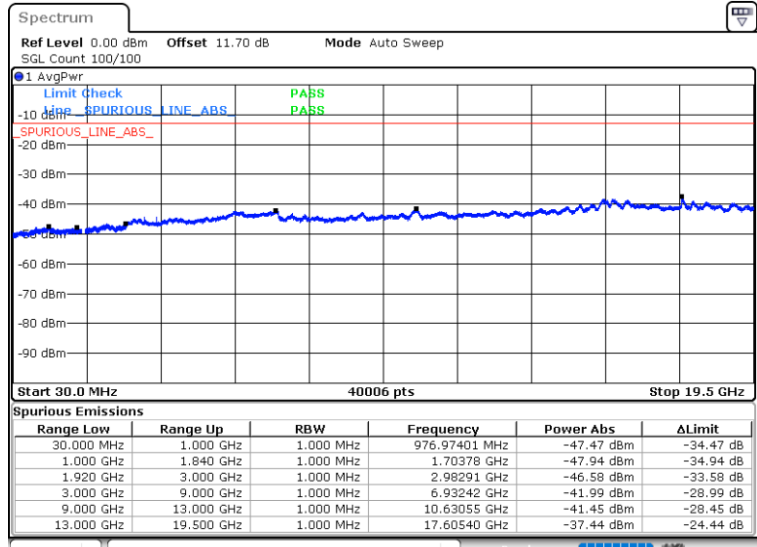

Date: 15.AUG.2021 10:09:34



LTE Band 2 / 10MHz

Lowest Channel / QPSK

Middle Channel / QPSK

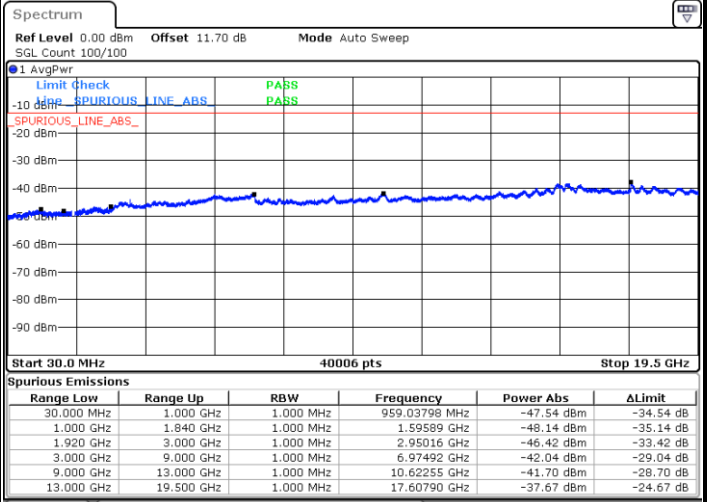
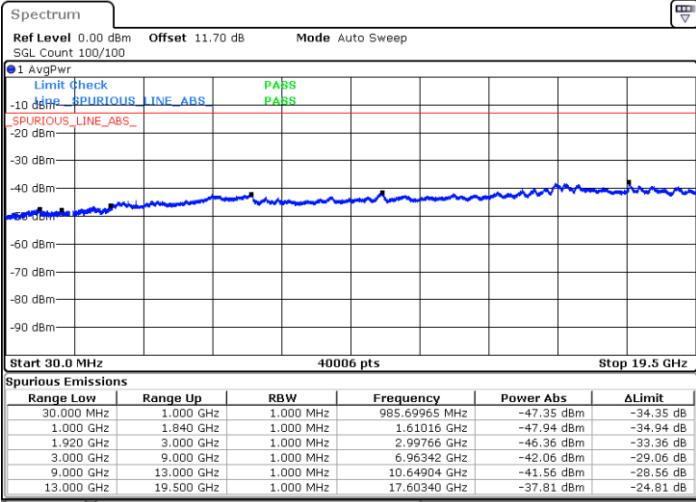

Date: 15.AUG.2021 10:11:50

Date: 15.AUG.2021 10:12:46

Highest Channel / QPSK

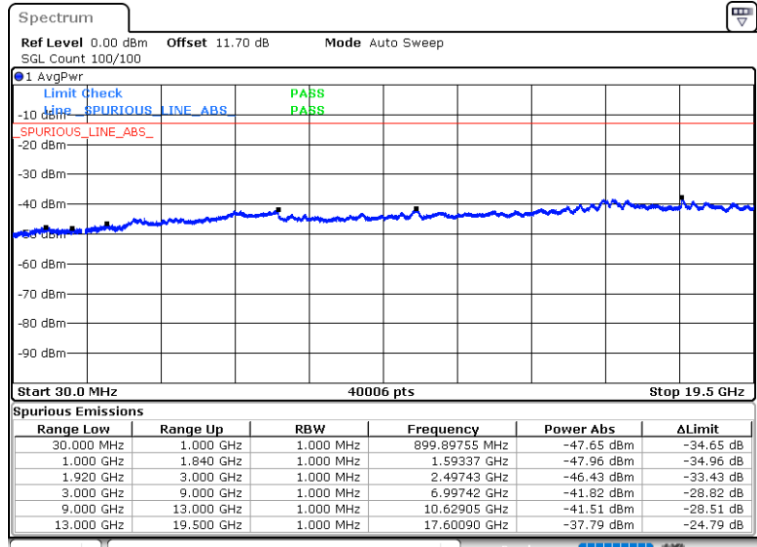

Date: 15.AUG.2021 10:14:59



LTE Band 2 / 15MHz

Lowest Channel / QPSK

Middle Channel / QPSK

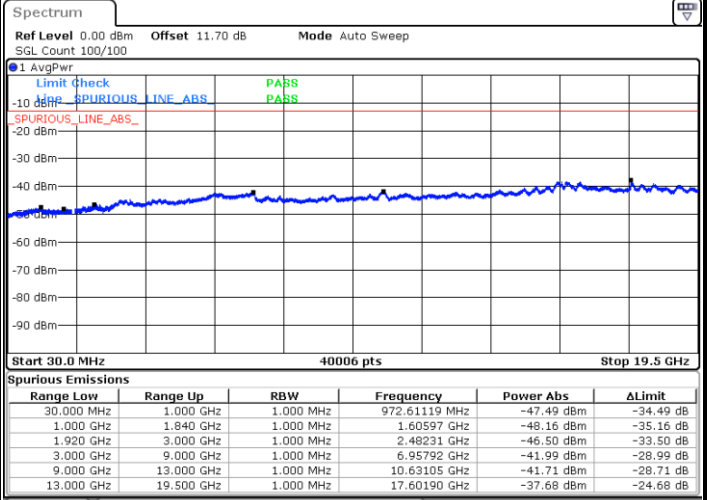
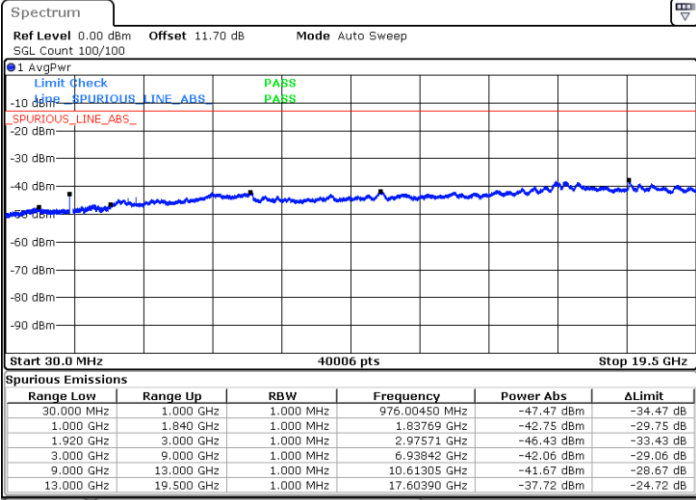

Date: 15.AUG.2021 10:17:14

Date: 15.AUG.2021 10:18:09

Highest Channel / QPSK

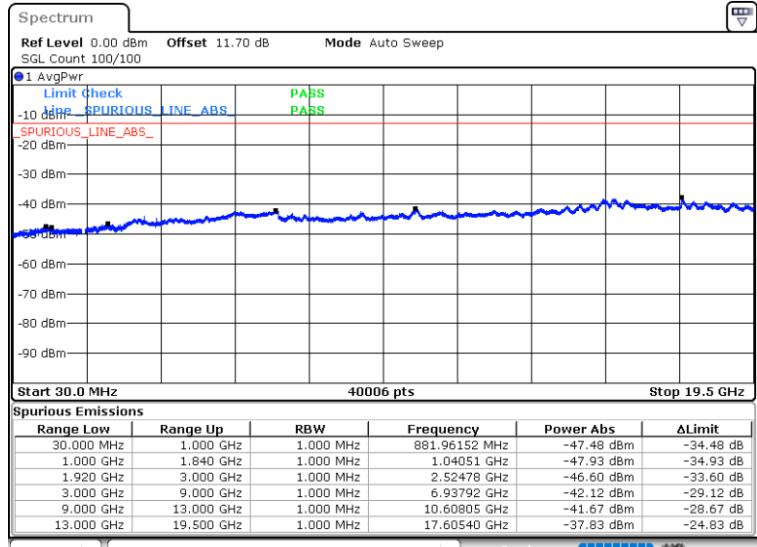

Date: 15.AUG.2021 10:20:23



LTE Band 2 / 20MHz

Lowest Channel / QPSK

Middle Channel / QPSK

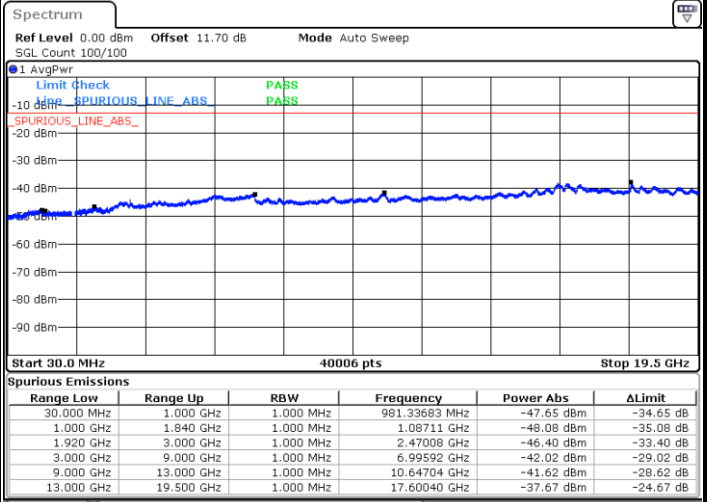
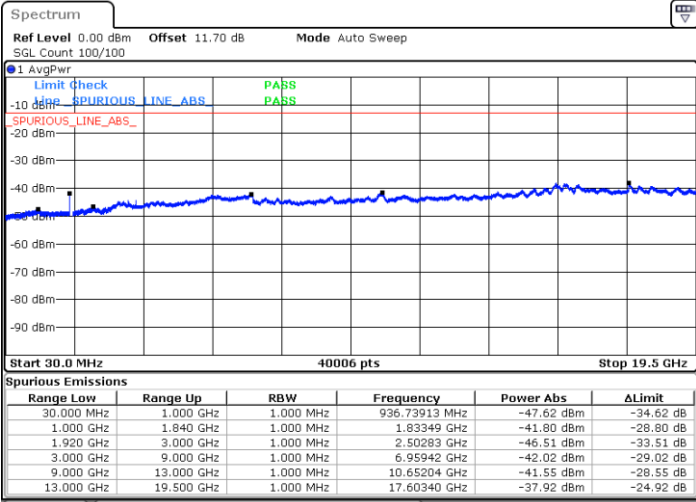

Date: 15.AUG.2021 10:22:38

Date: 15.AUG.2021 10:23:33

Highest Channel / QPSK

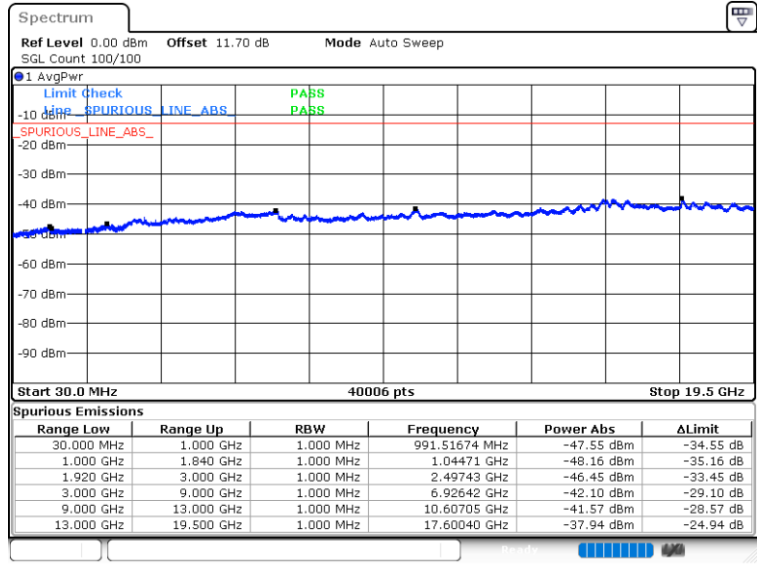

Date: 15.AUG.2021 10:26:23



LTE Band 4

Conducted Band Edge

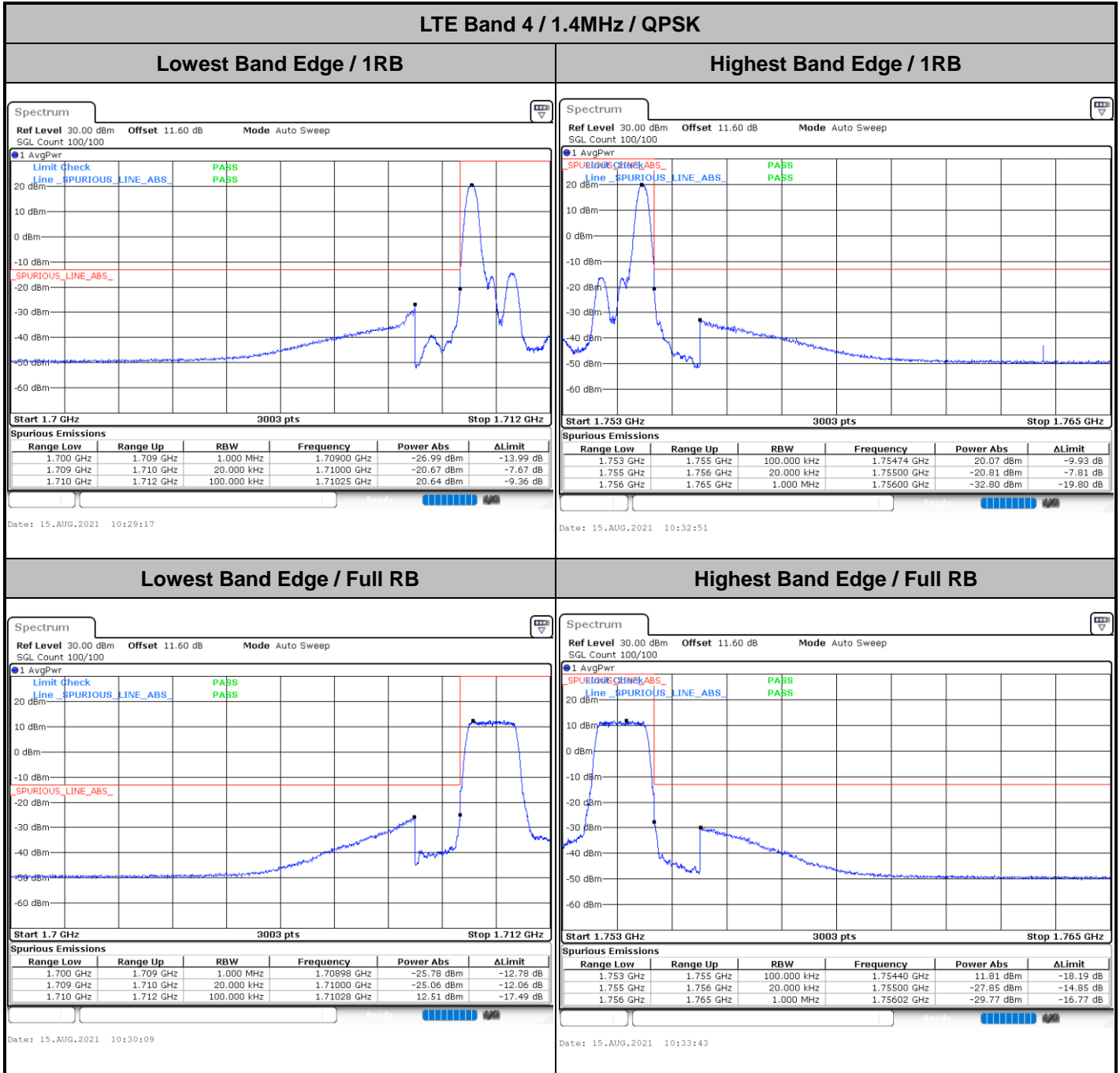



LTE Band 4 / 1.4MHz / 16QAM

Lowest Band Edge / 1 RB

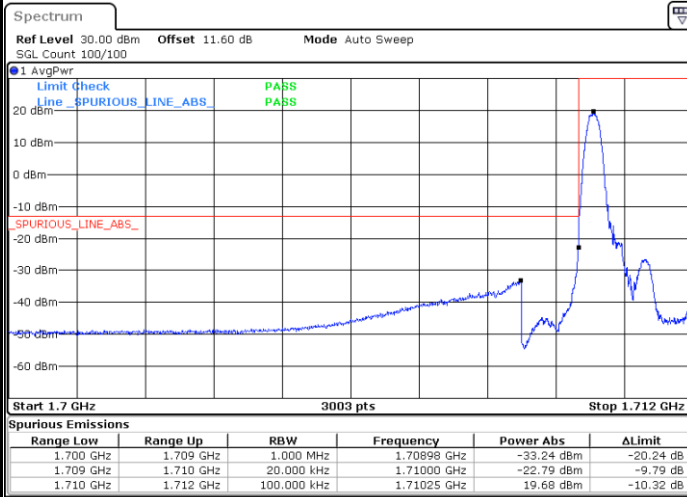

Date: 15.AUG.2021 10:29:43

Highest Band Edge / 1 RB

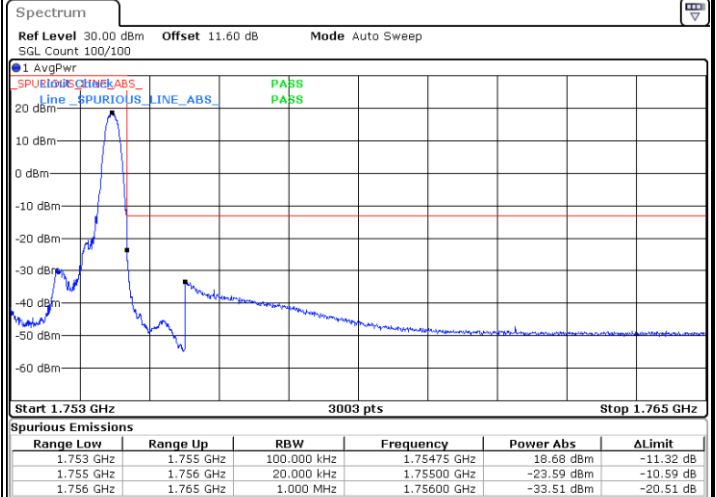

Date: 15.AUG.2021 10:33:17

Lowest Band Edge / Full RB

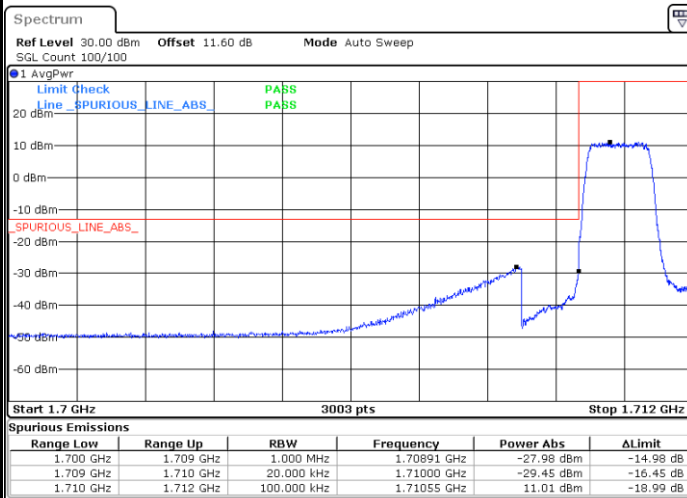

Date: 15.AUG.2021 10:30:35

Highest Band Edge / Full RB

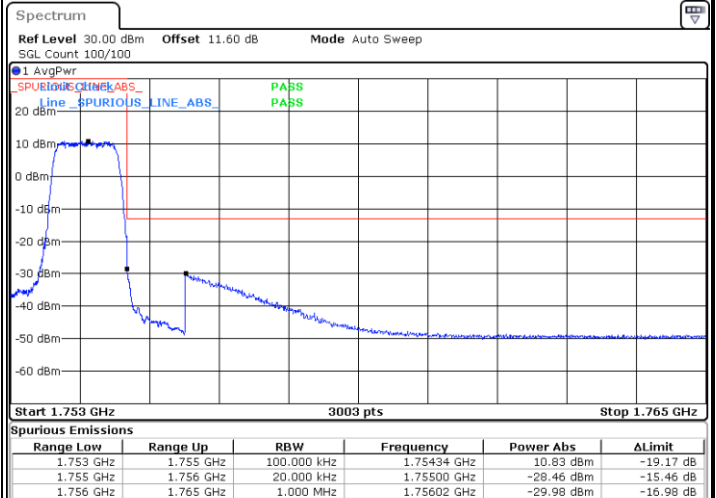

Date: 15.AUG.2021 10:34:09



LTE Band 4 / 3MHz / QPSK

Lowest Band Edge / 1RB

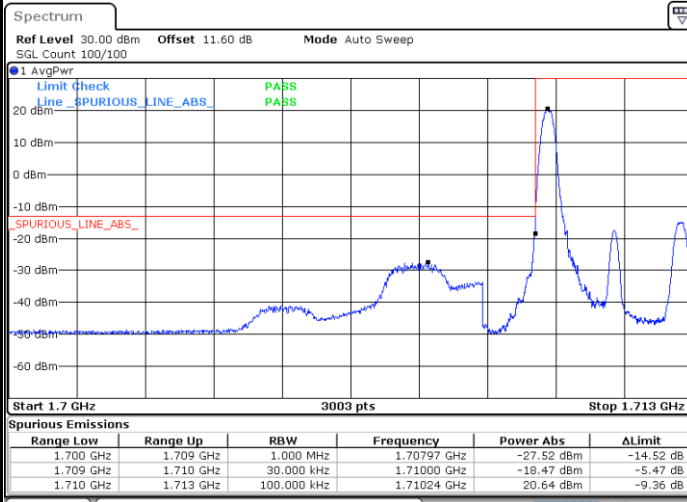

Date: 15.AUG.2021 10:35:32

Highest Band Edge / 1 RB

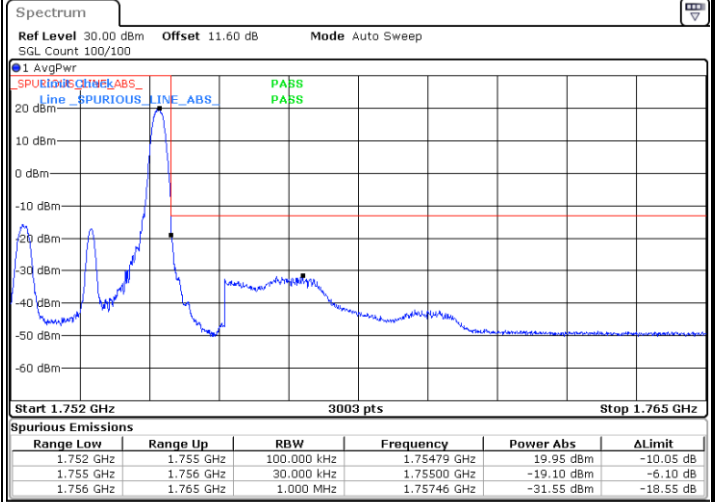

Date: 15.AUG.2021 10:40:13

Lowest Band Edge / Full RB

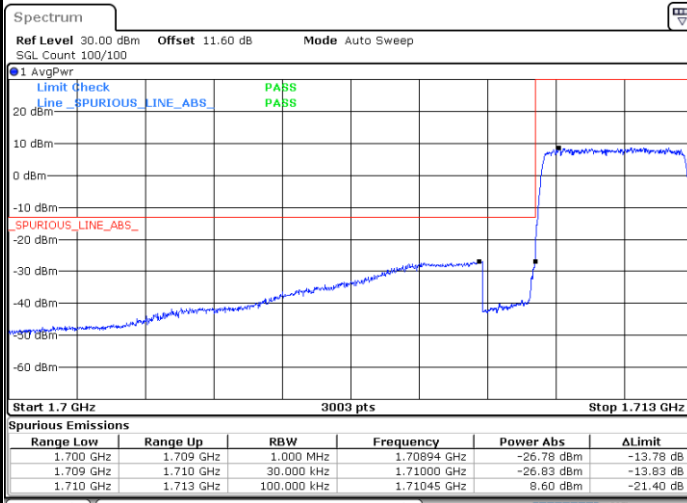

Date: 15.AUG.2021 10:36:23

Highest Band Edge / Full RB

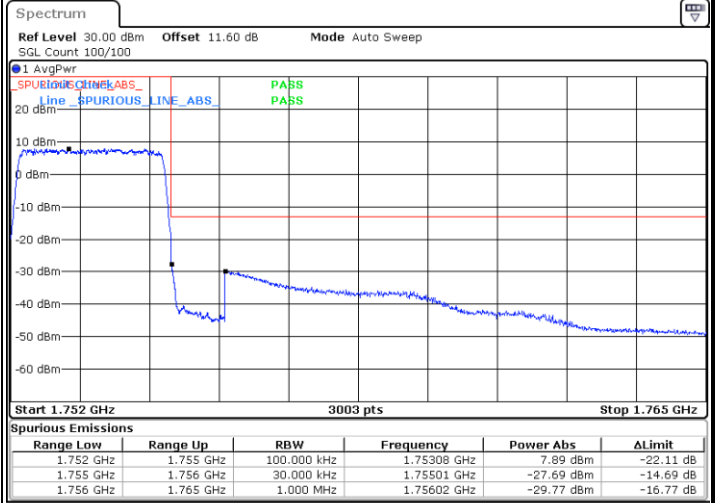

Date: 15.AUG.2021 10:41:08



LTE Band 4 / 3MHz / 16QAM

Lowest Band Edge / 1 RB

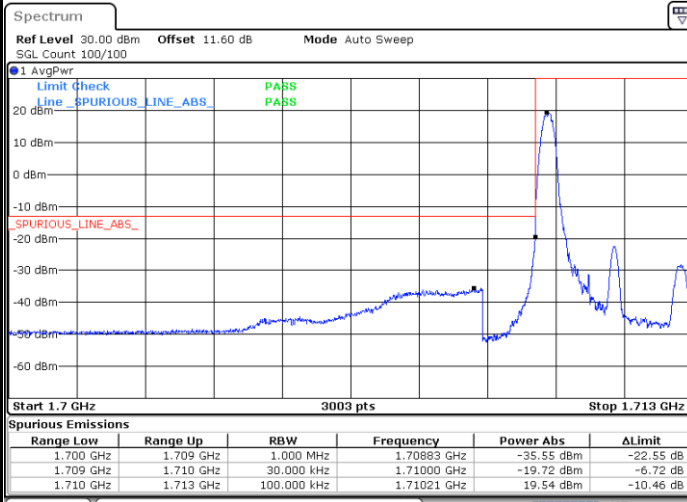

Date: 15.AUG.2021 10:35:57

Highest Band Edge / 1 RB

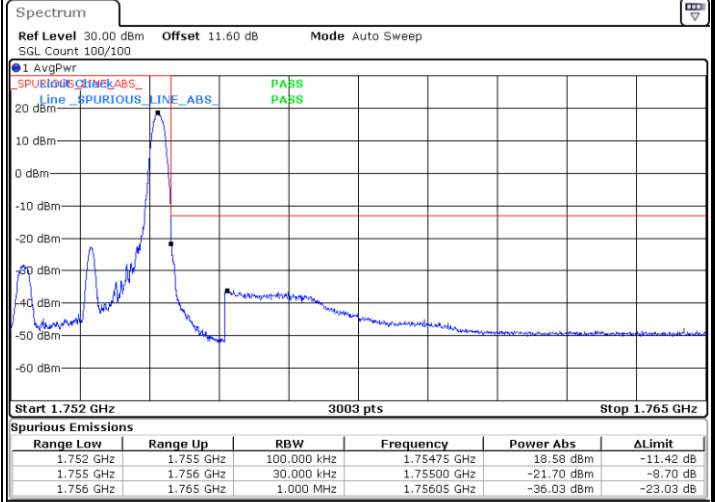

Date: 15.AUG.2021 10:40:42

Lowest Band Edge / Full RB

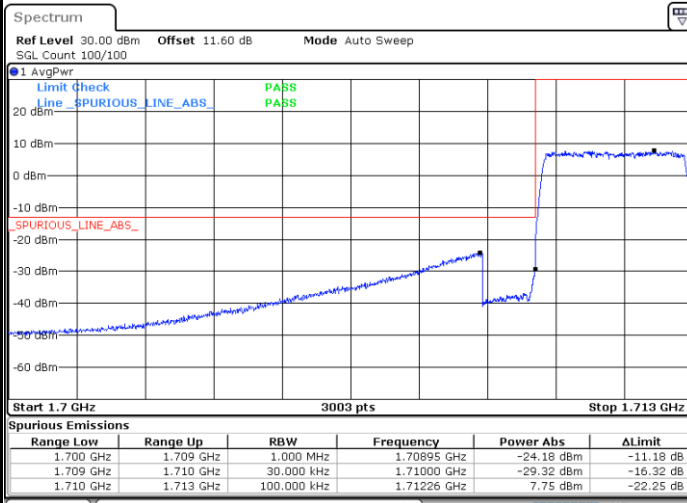

Date: 15.AUG.2021 10:36:49

Highest Band Edge / Full RB

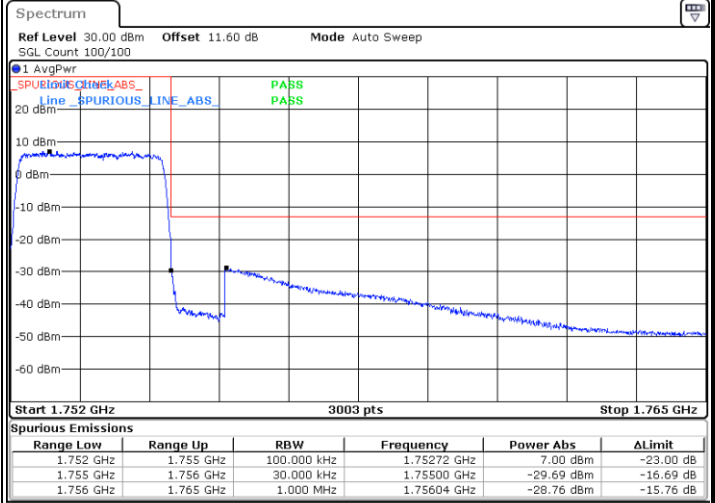

Date: 15.AUG.2021 10:41:33



LTE Band 4 / 5MHz / QPSK

Lowest Band Edge / 1 RB

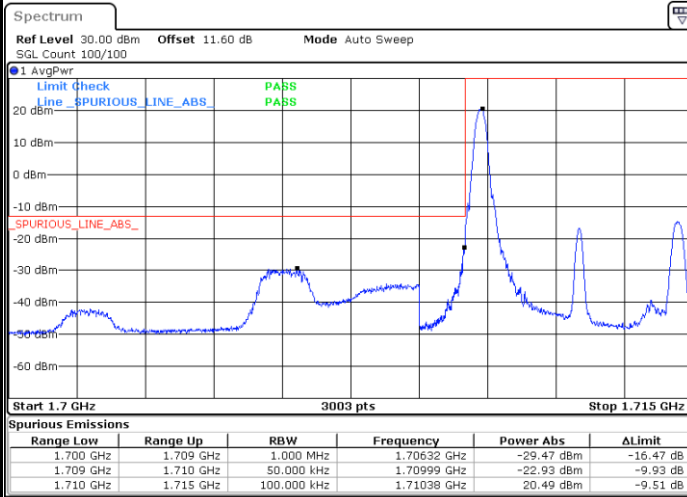

Date: 15.AUG.2021 10:42:57

Highest Band Edge / 1 RB

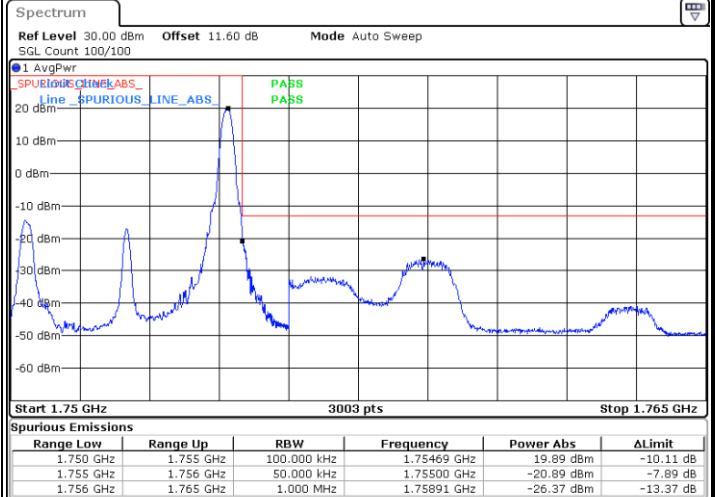

Date: 15.AUG.2021 10:46:32

Lowest Band Edge / Full RB

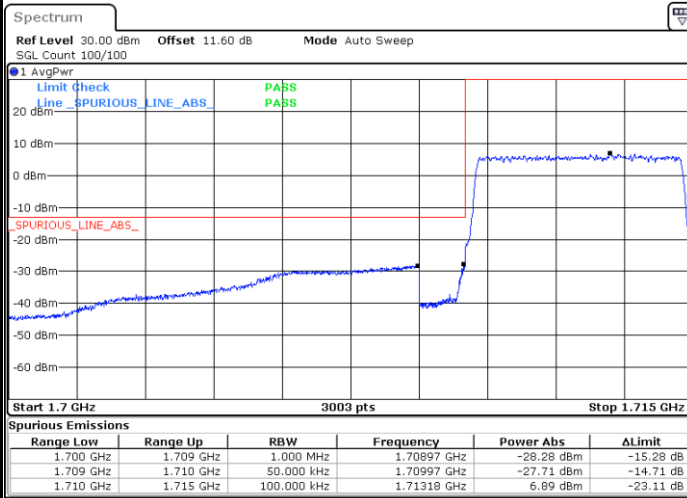

Date: 15.AUG.2021 10:43:49

Highest Band Edge / Full RB

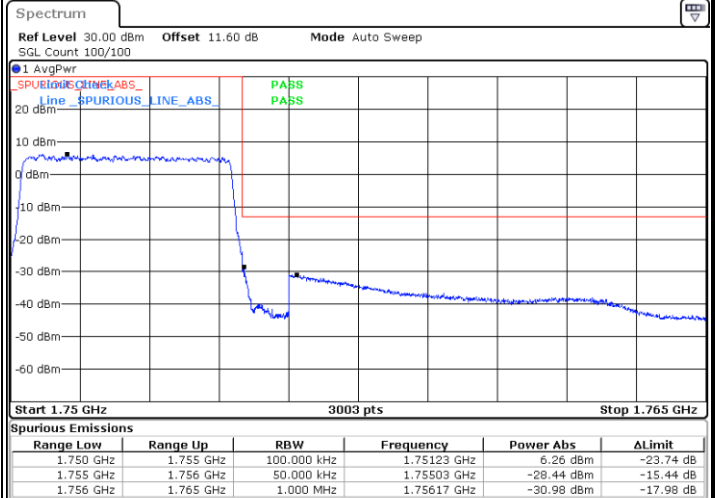

Date: 15.AUG.2021 10:47:24



LTE Band 4 / 5MHz / 16QAM

Lowest Band Edge / 1RB

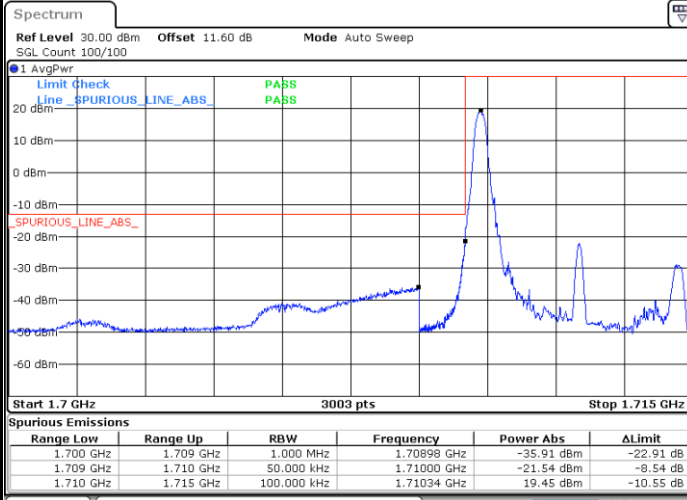

Date: 15.AUG.2021 10:43:23

Highest Band Edge / 1 RB

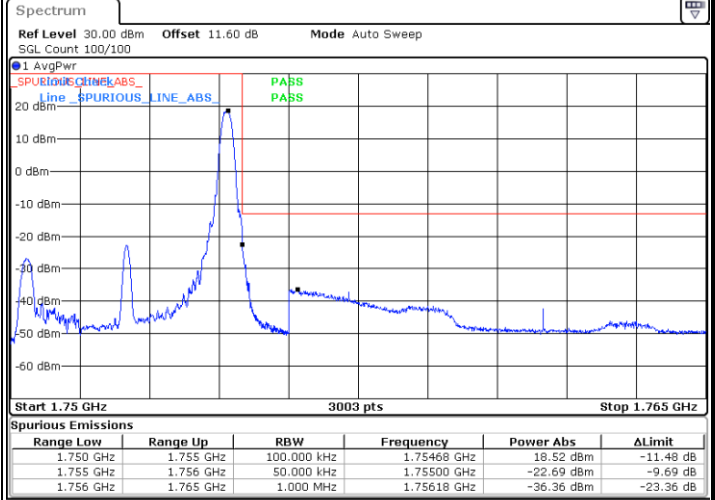

Date: 15.AUG.2021 10:46:58

Lowest Band Edge / Full RB

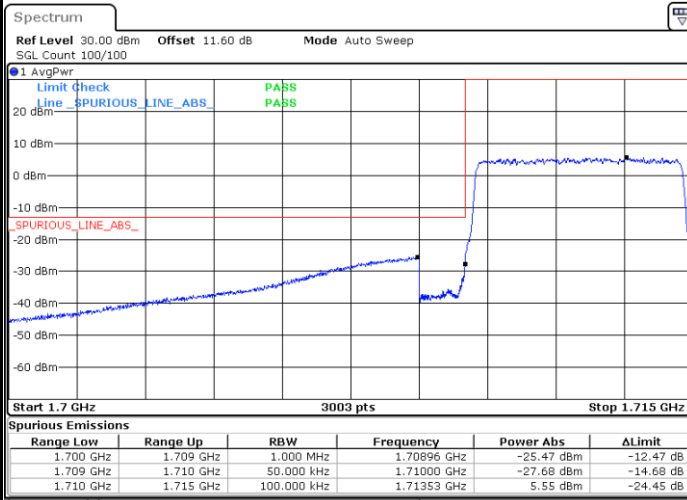

Date: 15.AUG.2021 10:44:14

Highest Band Edge / Full RB

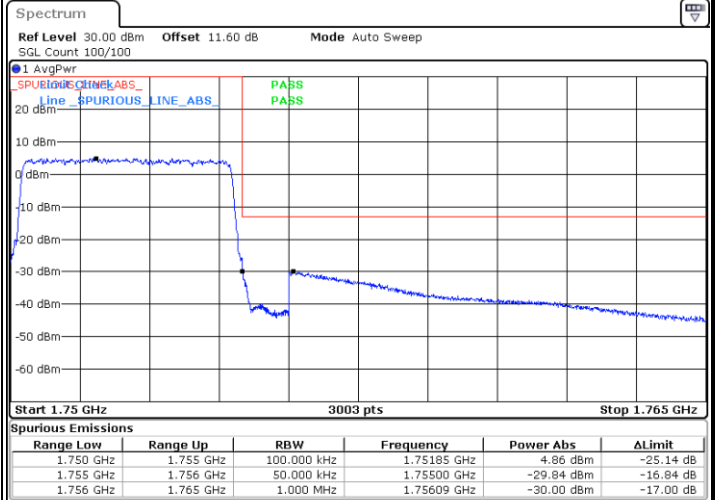

Date: 15.AUG.2021 10:47:50



LTE Band 4 / 10MHz / QPSK

Lowest Band Edge / 1 RB

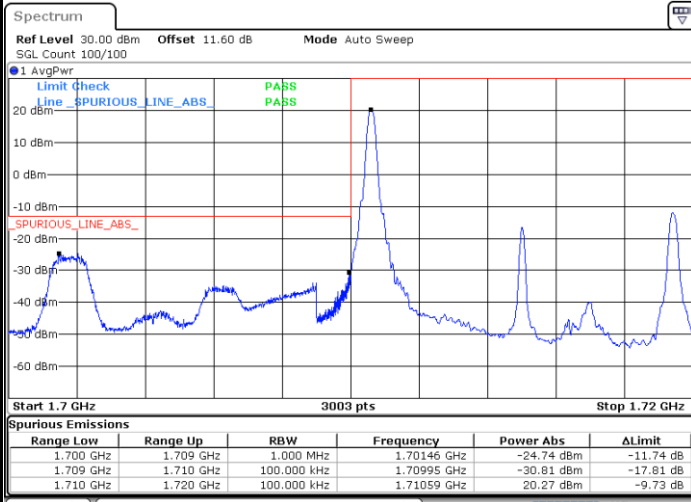

Date: 15.AUG.2021 10:49:13

Highest Band Edge / 1 RB

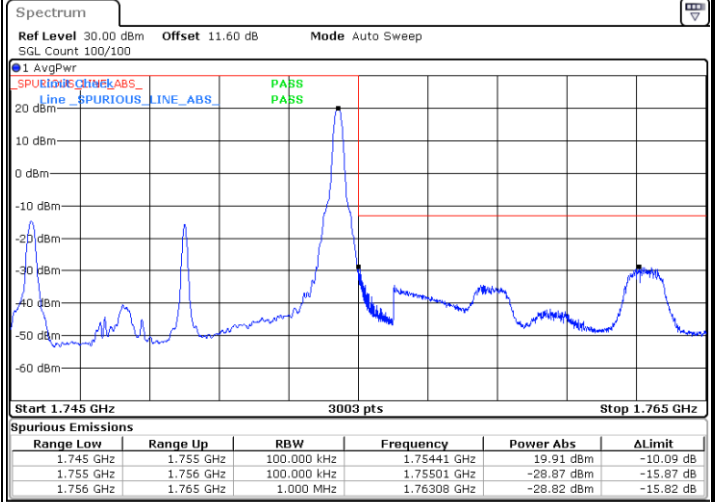

Date: 15.AUG.2021 10:54:00

Lowest Band Edge / Full RB

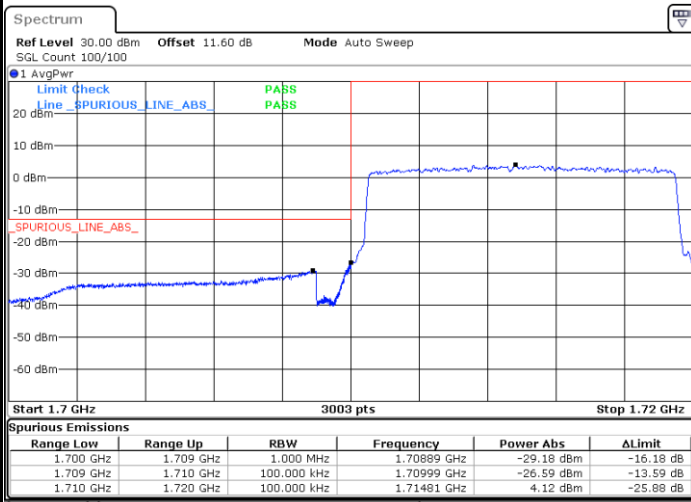

Date: 15.AUG.2021 10:50:05

Highest Band Edge / Full RB

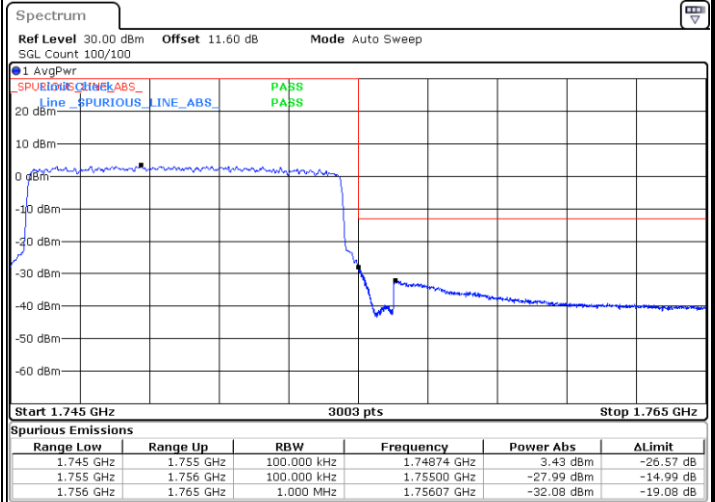

Date: 15.AUG.2021 10:54:51



LTE Band 4 / 10MHz / 16QAM

Lowest Band Edge / 1 RB

Highest Band Edge / 1 RB

