



# TEST REPORT

**Test Report No. : UL-RPT-RP-12163690-516-FCC**

**Applicant** : Healthup Sp.z. o.o.  
**Model** : AioCare 12/2017  
**FCC ID** : 2AP4V-AIOCARE  
**Technology** : Bluetooth – Low Energy  
**Test Standard(s)** : FCC Parts 15.207, 15.209 & 15.247

For details of applied tests refer to test result summary

1. This test report shall not be reproduced in full or partial, without the written approval of UL International Germany GmbH.
2. The results in this report apply only to the sample tested.
3. The test results in this report are traceable to the national or international standards.
4. Test Report Version 1.0
5. Result of the tested sample: **PASS**

Prepared by: Segun I. Adeniji  
Title: Engineer  
Date: 28.September.2018

Approved by: Ajit, Phadtare  
Title: Lead Test Engineer  
Date: 28.September.2018



Deutsche  
Akkreditierungsstelle  
D-PL-19381-02-00

This laboratory is accredited by DAkkS.  
The tests reported herein have been performed in  
accordance with its' terms of accreditation.

**UL INTERNATIONAL GERMANY GMBH**

Hedelfinger Str. 61  
70327 Stuttgart, Germany  
STU.CTECHLab@ul.com

This page has been left intentionally blank.

## **Table of Contents**

<b>1. Customer Information.....</b>	<b>4</b>
1.1.Applicant Information	4
1.2.Manufacturer Information	4
<b>2. Summary of Testing.....</b>	<b>5</b>
2.1. General Information	5
Applied Standards	5
Location	5
Date information	5
2.2. Summary of Test Results	6
2.3. Methods and Procedures	6
2.4. Deviations from the Test Specification	6
<b>3. Equipment Under Test (EUT) .....</b>	<b>7</b>
3.1. Identification of Equipment Under Test (EUT)	7
3.2. Description of EUT	9
3.3. Modifications Incorporated in the EUT	9
3.4. Additional Information Related to Testing	10
3.5. Support Equipment	10
A. Support Equipment (In-house)	10
B. Support Equipment (Manufacturer supplied)	10
<b>4. Operation and Monitoring of the EUT during Testing .....</b>	<b>11</b>
4.1. Operating Modes	11
4.2. Configuration and Peripherals	11
<b>5. Measurements, Examinations and Derived Results .....</b>	<b>12</b>
5.1. General Comments	12
5.2. Test Results	13
5.2.1. Transmitter AC Conducted Spurious Emissions	13
5.2.2. Transmitter Minimum 6 dB Bandwidth	17
5.2.3. Transmitter Maximum Peak Output Power	19
5.2.4. Transmitter Radiated Emissions	23
5.2.5. Transmitter Band Edge Radiated Emissions	30
<b>6. Measurement Uncertainty .....</b>	<b>34</b>
<b>7. Used equipment.....</b>	<b>35</b>
<b>8. Report Revision History .....</b>	<b>36</b>

## **1. Customer Information**

### **1.1.Applicant Information**

<b>Company Name:</b>	Healthup Sp. z o.o.
<b>Company Address:</b>	Smolna street 4, 00-375 Warsaw, POLAND
<b>Company Phone No.:</b>	+48601135486
<b>Company E-Mail:</b>	marta@healthup.pl
<b>Contact Person:</b>	Marta Kuznicka

### **1.2.Manufacturer Information**

<b>Company Name:</b>	Healthup Sp. z o.o.
<b>Company Address:</b>	Smolna street 4, 00-375 Warsaw, POLAND
<b>Company Phone No.:</b>	+48601135486
<b>Company E-Mail:</b>	marta@healthup.pl
<b>Contact Person:</b>	Marta Kuznicka

## **2. Summary of Testing**

### **2.1. General Information**

#### **Applied Standards**

<b>Specification Reference:</b>	47CFR15.247
<b>Specification Title:</b>	Code of Federal Regulations Volume 47 (Telecommunications): Part 15 Subpart C (Intentional Radiators) - Section 15.247
<b>Specification Reference:</b>	47CFR15.207 and 47CFR15.209
<b>Specification Title:</b>	Code of Federal Regulations Volume 47 (Telecommunications): Part 15 Subpart C (Intentional Radiators) - Sections 15.207 and 15.209
<b>Test Firm Registration:</b>	399704

#### **Location**

<b>Location of Testing:</b>	UL International Germany GmbH Hedelfinger Str. 61 70327 Stuttgart Germany
-----------------------------	--

#### **Date information**

<b>Order Date:</b>	31 January 2018
<b>EUT arrived:</b>	10 May 2018
<b>Test Dates:</b>	17 May – 29 May 2018
<b>EUT returned:</b>	-/-

## 2.2. Summary of Test Results

Clause	Measurement	Complied	Did not comply	Not performed	Not applicable
Part 15.207	Transmitter AC Conducted Emissions	<input checked="" type="checkbox"/>	<input type="checkbox"/>	<input type="checkbox"/>	<input type="checkbox"/>
Part 15.247(a)(2)	Transmitter Minimum 6 dB Bandwidth	<input checked="" type="checkbox"/>	<input type="checkbox"/>	<input type="checkbox"/>	<input type="checkbox"/>
Part 15.247(e)	Transmitter Power Spectral Density	<input type="checkbox"/>	<input type="checkbox"/>	<input type="checkbox"/>	<input checked="" type="checkbox"/>
Part 15.247(b)(3)	Transmitter Maximum Peak Output Power	<input checked="" type="checkbox"/>	<input type="checkbox"/>	<input type="checkbox"/>	<input type="checkbox"/>
Part 15.247(d)/15.209(a)	Transmitter Radiated Emissions	<input checked="" type="checkbox"/>	<input type="checkbox"/>	<input type="checkbox"/>	<input type="checkbox"/>
Part 15.247(d)/15.209(a)	Transmitter Band Edge Radiated Emissions	<input checked="" type="checkbox"/>	<input type="checkbox"/>	<input type="checkbox"/>	<input type="checkbox"/>

### Note(s):

1. In accordance with FCC KDB 558074 Section 10.1, PSD is not required if the maximum conducted output power is less than the PSD limit of 8 dBm / 3 kHz. The PSD level is therefore deemed to be equal to the measured total output power.

## 2.3. Methods and Procedures

<b>Reference:</b>	ANSI C63.10-2013
<b>Title:</b>	American National Standard of Procedures for Compliance Testing of Unlicensed Wireless Devices
<b>Reference:</b>	KDB 558074 D01 DTS Meas Guidance v04 April 5, 2017
<b>Title:</b>	Guidance for Performing Compliance Measurements on Digital Transmission Systems (DTS) Operating Under §15.247
<b>Reference:</b>	KDB 174176 D01 Line Conducted FAQ v01r01 June 3, 2015
<b>Title:</b>	AC Power-Line Conducted Emissions Frequently Asked Questions

## 2.4. Deviations from the Test Specification

For the measurements contained within this test report, there were no deviations from, additions to, or exclusions from the test specification identified above.

### 3. Equipment Under Test (EUT)

#### 3.1. Identification of Equipment Under Test (EUT)

<b>Brand Name:</b>	AioCare
<b>Model Name or Number:</b>	12/2017
<b>Test Sample Serial Number:</b>	Bottom Channel: MS082017007812 ( <i>Conducted Sample</i> )
<b>Hardware Version Number:</b>	1.7.2
<b>Software Version Number:</b>	2.0.0
<b>FCC ID:</b>	2AP4V-AIOCARE

<b>Brand Name:</b>	AioCare
<b>Model Name or Number:</b>	12/2017
<b>Test Sample Serial Number:</b>	Middle Channel: MS122017007912 ( <i>Conducted Sample</i> )
<b>Hardware Version Number:</b>	1.7.2
<b>Software Version Number:</b>	2.0.0
<b>FCC ID:</b>	2AP4V-AIOCARE

<b>Brand Name:</b>	AioCare
<b>Model Name or Number:</b>	12/2017
<b>Test Sample Serial Number:</b>	Top Channel: MS122017001112 ( <i>Conducted Sample</i> )
<b>Hardware Version Number:</b>	1.7.2
<b>Software Version Number:</b>	2.0.0
<b>FCC ID:</b>	2AP4V-AIOCARE

<b>Brand Name:</b>	AioCare
<b>Model Name or Number:</b>	12/2017
<b>Test Sample Serial Number:</b>	Bottom Channel: MS122017017612 ( <i>Radiated Sample</i> )
<b>Hardware Version Number:</b>	1.7.2
<b>Software Version Number:</b>	2.0.0
<b>FCC ID:</b>	2AP4V-AIOCARE

<b>Brand Name:</b>	AioCare
<b>Model Name or Number:</b>	12/2017
<b>Test Sample Serial Number:</b>	Middle Channel: MS122017015112 ( <i>Radiated Sample</i> )
<b>Hardware Version Number:</b>	1.7.2
<b>Software Version Number:</b>	2.0.0
<b>FCC ID:</b>	2AP4V-AIOCARE

<b>Brand Name:</b>	AioCare
<b>Model Name or Number:</b>	12/2017
<b>Test Sample Serial Number:</b>	Top Channel: MS122017017112 ( <i>Radiated Sample</i> )
<b>Hardware Version Number:</b>	1.7.2
<b>Software Version Number:</b>	2.0.0
<b>FCC ID:</b>	2AP4V-AIOCARE



### **3.2. Description of EUT**

The equipment under test was a spirometer supporting Bluetooth Low energy communications & Wireless Power Transfer (WPT) charging.

### **3.3. Modifications Incorporated in the EUT**

No modifications were applied to the EUT during testing.

**3.4. Additional Information Related to Testing**

<b>Technology Tested:</b>	Bluetooth Low Energy (Digital Transmission System)		
<b>Type of Unit:</b>	Transceiver		
<b>Channel Spacing:</b>	2 MHz		
<b>Modulation:</b>	GFSK		
<b>Data Rate:</b>	1 Mbps		
<b>Power Supply Requirement(s):</b>	Nominal	3.5 VDC - 4.2 VDC	
<b>Antenna Designation:</b>	2450AT18B100E		
<b>Antenna Type:</b>	High Frequency Ceramic Antenna		
<b>Antenna Gain:</b>	0.5 dBi (Peak)		
<b>Transmit Frequency Range:</b>	2402 MHz to 2480 MHz		
<b>Transmit Channels Tested:</b>	<b>Channel ID</b>	<b>RF Channel</b>	<b>Channel Frequency (MHz)</b>
	Bottom	0	2402
	Middle	19	2440
	Top	39	2480

**3.5. Support Equipment**

The following support equipment was used to exercise the EUT during testing:

**A. Support Equipment (In-house)**

Item	Description	Brand Name	Model Name or Number	Serial Number
1	USB AC/DC Adaptor	Samsung	-	DW4D520DS/B-E

**B. Support Equipment (Manufacturer supplied)**

Item	Description	Brand Name	Model Name or Number	Serial Number
1	1.5m USB Charging Cable with Ferrite	Sony	Not Stated	Not Stated

## **4. Operation and Monitoring of the EUT during Testing**

### **4.1. Operating Modes**

The EUT was tested in the following operating mode(s):

Transmitting at maximum power in *Bluetooth* LE mode with modulation, maximum possible data length.

Idle Mode

### **4.2. Configuration and Peripherals**

The EUT was tested in the following configuration(s):

- The EUT was powered via the fully charged internal battery integrated within the EUT.
- The manufacturer has set the all EUTs to transmit at the highest output power.
- The EUT conducted samples were used for 6 dB bandwidth, 99% emission bandwidth, power spectral density and maximum peak output power measurements.
- Each conducted EUT sample was supplied with a short length of RF cable attached to the antenna connector in order to support RF conducted test measurements. This cable introduced a loss of 1dB @ 2400MHz. This has been taken in to account with the measured conducted values.”
- The EUT radiated samples were used for AC conducted emissions and radiated spurious emissions measurements.

## **5. Measurements, Examinations and Derived Results**

### **5.1. General Comments**

Measurement uncertainties are evaluated in accordance with current best practice. Our reported expanded uncertainties are based on standard uncertainties, which are multiplied by an appropriate coverage factor to provide a statistical confidence level of approximately 95%. Please refer to Section 6 *Measurement Uncertainty* for details.

In accordance with DAkkS requirements all the measurement equipment is on a calibration schedule. All equipment was within the calibration period on the date of testing.

## **5.2. Test Results**

### **5.2.1. Transmitter AC Conducted Spurious Emissions**

#### **Test Summary:**

<b>Test Engineer:</b>	Asim	<b>Test Date:</b>	29.05.2018
<b>Test Sample Serial Number:</b>	MS122017015112		
<b>Test Site Identification</b>	SR 7/8		

<b>Clause:</b>	Part 15.207
<b>Test Method:</b>	ANSI C63.10 Section 6.2 / FCC KDB 174176 and notes below

#### **Environmental Conditions:**

<b>Temperature (°C):</b>	20
<b>Relative Humidity (%):</b>	38

#### **Settings of the Instrument**

<b>Detector</b>	Quasi Peak/ Average Peak
-----------------	--------------------------

#### **Note(s):**

1. The EUT was connected to an AC/DC Adaptor.
2. The EUT Adaptor was connected to a 120 VAC 60 Hz single phase supply via a LISN.
3. The final measured value, for the given emission, in the table below incorporates the cable loss.
4. All other emissions shown on the pre-scan plot were investigated and found to be ambient or >20 dB below the applicable limit or below the measurement system noise floor.
5. Measurements were performed in shielded room (SR7/ 8 Asset Number 1603671). The EUT was placed at a height of 80 cm above the reference ground plane and in a distance of 40 cm from the vertical ground plane at the edge of the table.

**Transmitter AC Conducted Spurious Emissions (continued)**

**Test setup:**

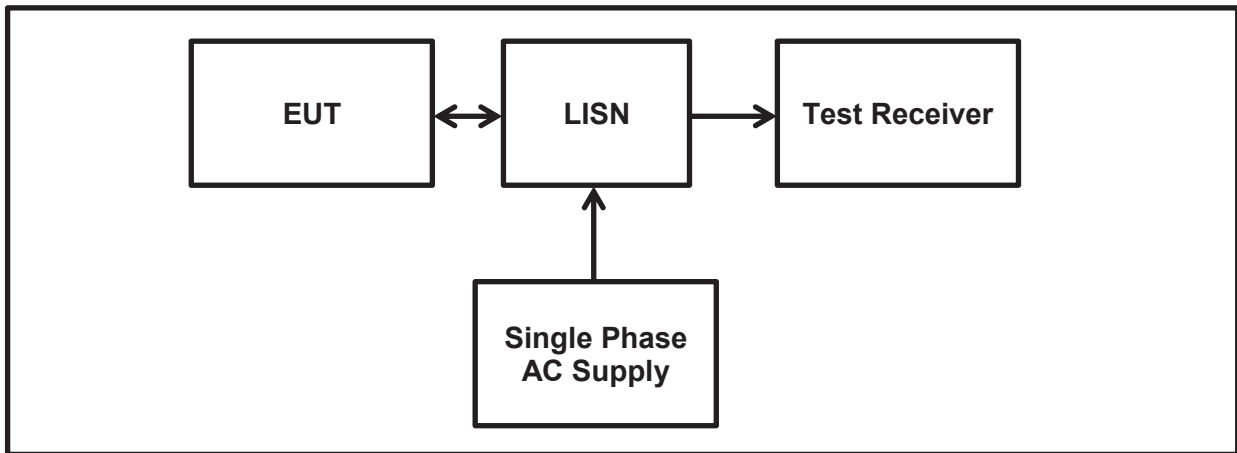

**Results: Live / Quasi Peak / 120 VAC 60 Hz**

Frequency (MHz)	Line	Level (dBµV)	Limit (dBµV)	Margin (dB)	Result
0.43128	Live	24.4	57.2	32.8	Complied
0.74829	Live	32.3	56	23.7	Complied
1.27156	Live	25.6	56	30.4	Complied
3.16451	Live	22.5	56	33.5	Complied
5.84802	Live	20.9	60	39.1	Complied
18.76675	Live	29	60	31	Complied

**Results: Live / Average / 120 VAC 60 Hz**

Frequency (MHz)	Line	Level (dBµV)	Limit (dBµV)	Margin (dB)	Result
0.43128	Live	12.6	47.2	34.6	Complied
0.74829	Live	18.8	46	27.2	Complied
1.27156	Live	13	46	33	Complied
3.16451	Live	9.9	46	36.1	Complied
5.84802	Live	9.4	50	40.6	Complied
18.76675	Live	15.9	50	34.1	Complied

**Results: Neutral / Quasi Peak / 120 VAC 60 Hz**

Frequency (MHz)	Line	Level (dBµV)	Limit (dBµV)	Margin (dB)	Result
0.25074	Neutral	25.5	61.7	36.2	Complied
0.52361	Neutral	23.7	56	32.3	Complied
0.74551	Neutral	32.5	56	23.5	Complied
1.35743	Neutral	23.1	56	32.9	Complied
2.24603	Neutral	23.9	56	32.1	Complied
19.19806	Neutral	29.2	60	30.8	Complied

**Results: Neutral / Average / 120 VAC 60 Hz**

Frequency (MHz)	Line	Level (dBµV)	Limit (dBµV)	Margin (dB)	Result
0.25074	Neutral	14.3	51.7	37.4	Complied
0.52361	Neutral	10.8	46	35.2	Complied
0.74551	Neutral	16.9	46	29.1	Complied
1.35743	Neutral	10.4	46	35.6	Complied
2.24603	Neutral	9.9	46	36.1	Complied
19.19806	Neutral	14.4	50	35.6	Complied

**Result: Pass**



**Plot: Live and Neutral Line**

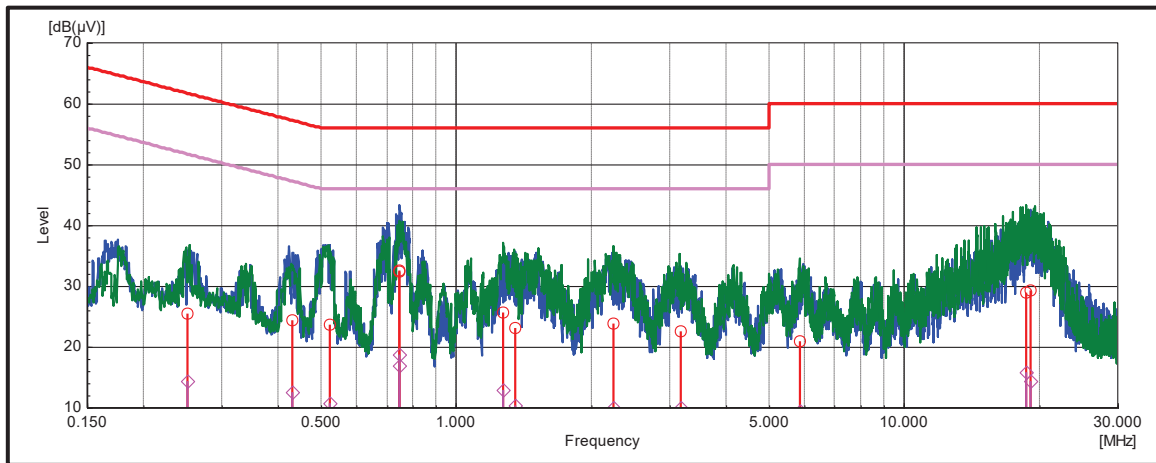

*Note: These plots are pre-scans and for indication purposes only. For final measurements, see accompanying tables.*



**5.2.2. Transmitter Minimum 6 dB Bandwidth**

**Test Summary:**

<b>Test Engineer:</b>	Segun Adeniji	<b>Test Date:</b>	18 May 2018
<b>Test Sample Serial Number:</b>	MS082017007812, MS122017007912, MS122017001112		
<b>Test Site Identification</b>	SR 9		

<b>FCC Reference:</b>	Part 15.247(a)(2)
<b>Test Method Used:</b>	FCC KDB 558074 Section 8.1 Option 1

**Environmental Conditions:**

<b>Temperature (°C):</b>	23
<b>Relative Humidity (%):</b>	33

**Note(s):**

1. 6 dB DTS bandwidth tests were performed using a spectrum analyser in accordance with FCC KDB 558074 Section 8.1 Option 1 measurement procedure. The spectrum analyser resolution bandwidth was set to 100 kHz and video bandwidth 300 kHz. A peak detector was used, sweep time was set to auto and the trace mode was Max Hold. The DTS bandwidth was measured at 6 dB down from the peak of the signal.
2. The spectrum analyser was connected to the RF port on the EUT using suitable attenuation and RF cable.

**Test Setup:**

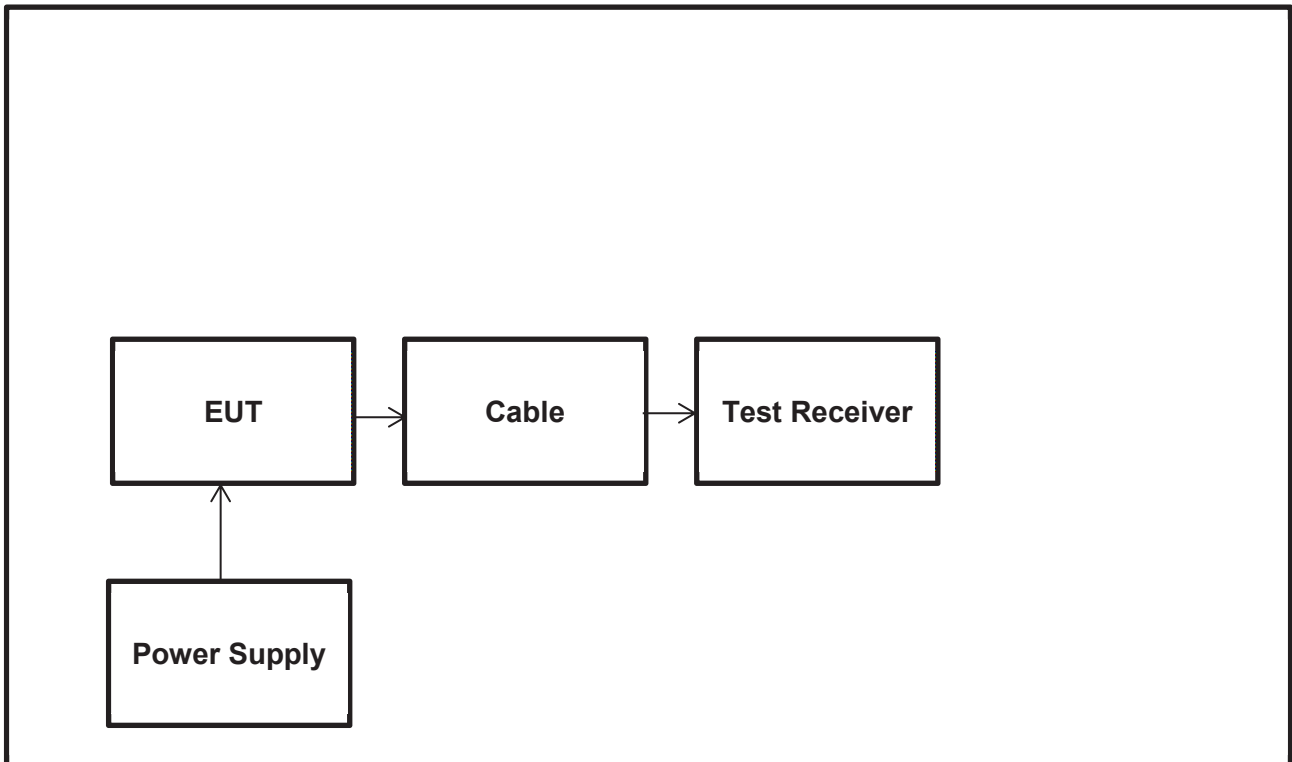

**Results:**

Channel	6 dB Bandwidth (kHz)	Limit (kHz)	Margin (kHz)	Result
Bottom	752.476	≥500	252.476	Complied
Middle	752.476	≥500	252.476	Complied
Top	752.476	≥500	252.476	Complied

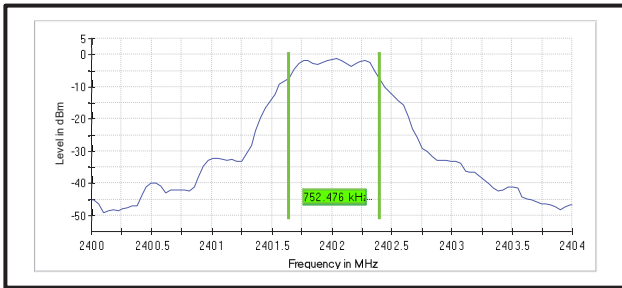

**Bottom Channel**

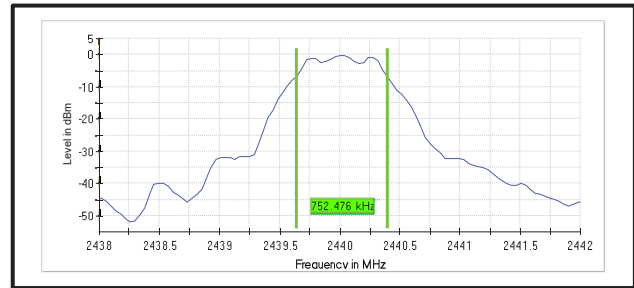

**Middle Channel**

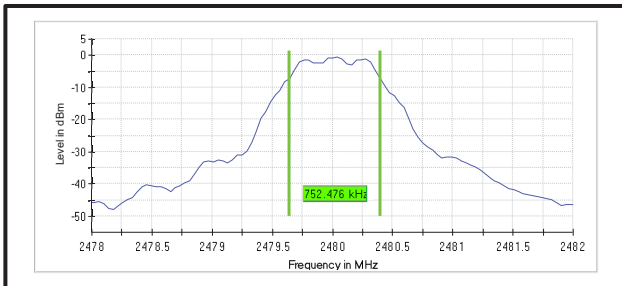

**Top Channel**

**Result: Pass**

**System Measurement Settings:**

Setting	Instrument Value	Target Value
Start Frequency	2.43800 GHz	2.43800 GHz
Stop Frequency	2.44200 GHz	2.44200 GHz
Span	4.000 MHz	4.000 MHz
RBW	100.000 kHz	~ 100.000 kHz
VBW	300.000 kHz	~ 300.000 kHz
SweepPoints	101	~ 40
SweepTime	18.938 μs	AUTO
Reference Level	-10.000 dBm	-10.000 dBm
Attenuation	10.000 dB	AUTO
Detector	MaxPeak	MaxPeak
SweepCount	100	100
Filter	3 dB	3 dB
Trace Mode	Max Hold	Max Hold
Sweeptype	FFT	AUTO
Preamp	off	off
Stablemode	Trace	Trace
Stablevalue	0.50 dB	0.50 dB
Run	13 / max. 150	max. 150
Stable	5 / 5	5
Max Stable Difference	0.00 dB	0.50 dB

### **5.2.3. Transmitter Maximum Peak Output Power**

#### **Test Summary:**

<b>Test Engineer:</b>	Segun Adeniji	<b>Test Date:</b>	18 May 2018
<b>Test Sample Serial Number:</b>	MS082017007812, MS122017007912, MS122017001112		
<b>Test Site Identification</b>	SR 9		

<b>FCC Reference:</b>	Part 15.247(b)(3)
<b>Test Method Used:</b>	FCC KDB 558074 Section 9.1.1

#### **Environmental Conditions:**

<b>Temperature (°C):</b>	23
<b>Relative Humidity (%):</b>	34

#### **Note(s):**

1. Conducted power tests were performed using a spectrum analyser in accordance with FCC KDB 558074 Section 9.1.1 with the RBW > *DTS bandwidth* procedure.
2. The signal analyser resolution bandwidth was set to 3 MHz and video bandwidth of 10 MHz. A peak detector was used, sweep time was set to auto and trace mode was Max Hold. The span was set to 9 MHz. A marker was placed at the peak of the signal and the results recorded in the table below.
3. The spectrum analyser was connected to the RF port on the EUT using suitable attenuation and RF cable. An RF level offset was entered on the spectrum analyser to compensate for the loss of the attenuator and RF cable.
4. The measurement was made with highest possible duty cycle
5. The conducted power was added to the declared antenna gain to obtain the EIRP.

**Test setup:**

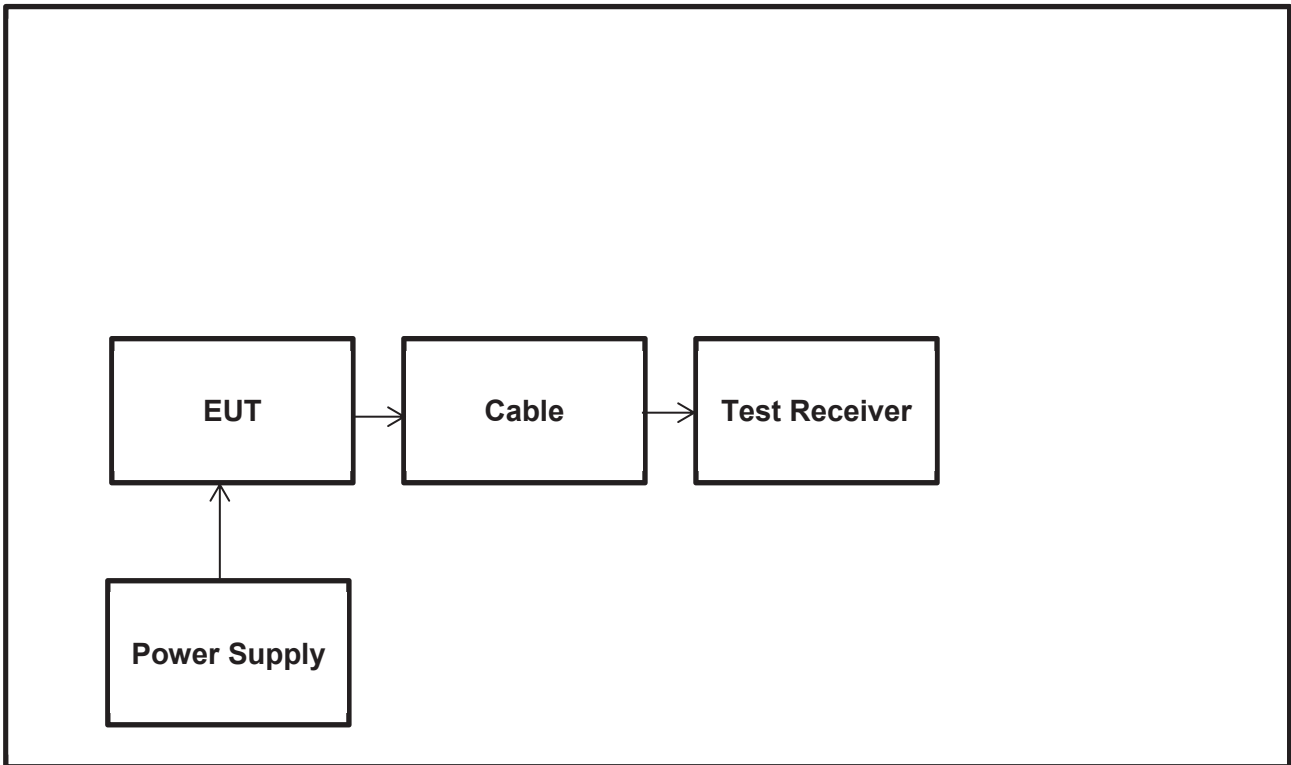

**Results:**

Channel	Measured Conducted Peak Power (dBm)	Cable Loss (dB)	Effective Conducted Peak Power (dBm)	Conducted Peak Power Limit (dBm)	Margin (dB)	Result
Bottom	-0.8	1.0	<b>0.2</b>	30.0	29.8	Complied
Middle	-0.1	1.0	<b>0.9</b>	30.0	29.1	Complied
Top	-0.5	1.0	<b>0.5</b>	30.0	29.5	Complied

Channel	Conducted Peak Power (dBm)	Declared Antenna Gain (dBi)	EIRP (dBm)	De Facto EIRP Limit (dBm)	Margin (dB)	Result
Bottom	0.2	0.5	<b>0.7</b>	36.0	35.3	Complied
Middle	0.9	0.5	<b>1.4</b>	36.0	34.6	Complied
Top	0.5	0.5	<b>1.0</b>	36.0	35.0	Complied

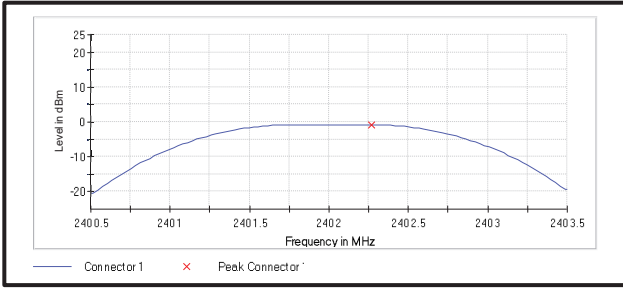

**Bottom Channel**

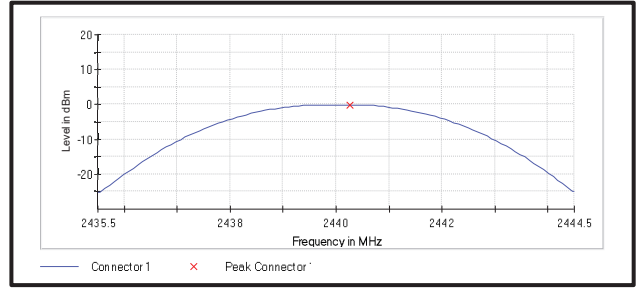

**Middle Channel**

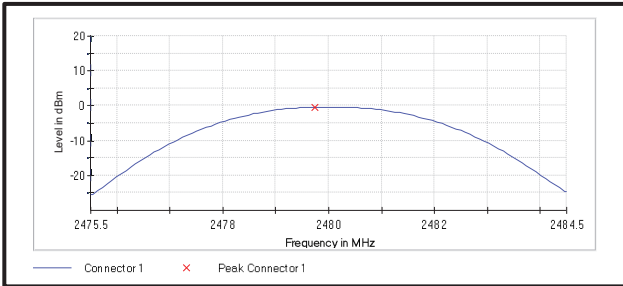

**Top Channel**

**Result: Pass**

**System Measurement Settings:**

Setting	Instrument Value	Target Value
Start Frequency	2.43550 GHz	2.43550 GHz
Stop Frequency	2.44450 GHz	2.44450 GHz
Span	9.000 MHz	9.000 MHz
RBW	3.000 MHz	>= 3.000 MHz
VBW	10.000 MHz	>= 9.000 MHz
SweepPoints	101	~ 101
Sweeptime	1.271 $\mu$ s	AUTO
Reference Level	10.000 dBm	10.000 dBm
Attenuation	30.000 dB	AUTO
Detector	MaxPeak	MaxPeak
SweepCount	100	100
Filter	3 dB	3 dB
Trace Mode	Max Hold	Max Hold
Sweeptype	FFT	AUTO
Preamp	off	off
Stablemode	Trace	Trace
Stablevalue	0.50 dB	0.50 dB
Run	-1 / max. 150	max. 150
Stable	-1 / 3	3
Max Stable Difference	-1.00 dB	0.50 dB

**5.2.4. Transmitter Radiated Emissions**

**Test Summary:**

<b>Test Engineer:</b>	Segun Adeniji	<b>Test Date:</b>	20 May 2018
<b>Test Sample Serial Number:</b>	MS122017017612; MS122017015112; MS122017017112		
<b>Test Site Identification</b>	SR 1/2		

<b>FCC Reference:</b>	Parts 15.247(d) & 15.209
<b>Test Method Used:</b>	ANSI C63.10 Sections 6.3 and 6.5
<b>Frequency Range</b>	30 MHz to 1000 MHz

**Environmental Conditions:**

<b>Temperature (°C):</b>	21
<b>Relative Humidity (%):</b>	41

**Note(s):**

1. The final measured value, for the given emission, in the table below incorporates the calibrated antenna factor and cable loss.
2. The preliminary scans showed similar emission levels below 1 GHz, for each channel of operation. Therefore final radiated emissions measurements were performed with the EUT set to the worst case i.e. bottom channel only.
3. Measurements below 1 GHz were performed in a semi-anechoic chamber at a distance of 3 metres. The EUT was placed at a height of 80 cm above the reference ground plane in the centre of the chamber turntable. Maximum emission levels were determined by height searching the measurement antenna over the range 1 metre to 4 metres.
4. Pre-scans were performed and markers placed on the highest measured levels. The test receiver resolution bandwidth was set to 100 kHz and video bandwidth 300 kHz. A peak detector was used, sweep time was set to auto and trace mode was Max Hold.
5. Final measurements were performed on the marker frequencies and the results entered into the table below. The test receiver resolution bandwidth was set to 120 kHz, using a CISPR quasi-peak detector and span big enough to see the whole emission.

**Test Setup:**

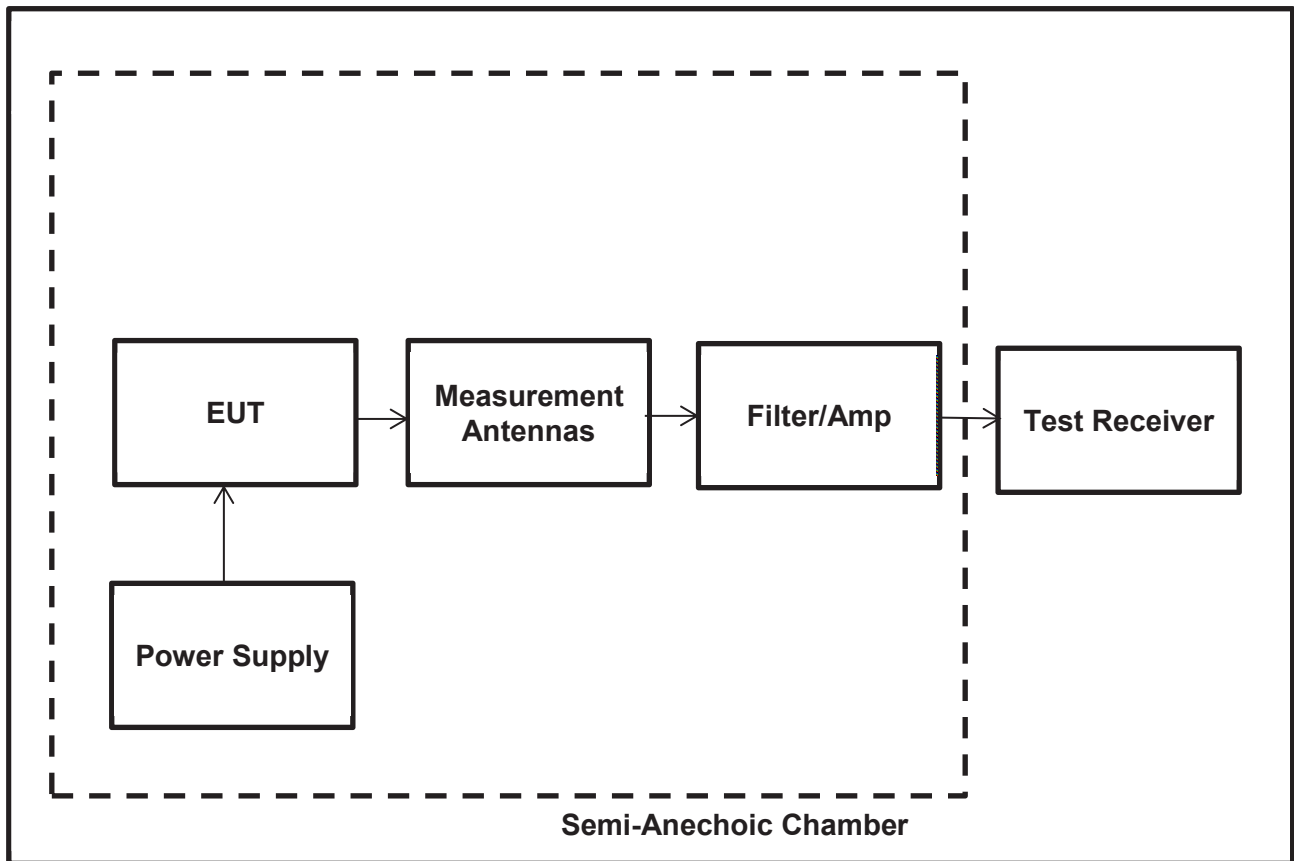



**Results: Bottom Channel**

Frequency (MHz)	Antenna Polarization	MaxPeak Level (dB $\mu$ V/m)	Limit (dB $\mu$ V/m)	Margin (dB)	Result
39.76	V	14.25	40.00	25.75	Complied
51.64	V	15.33	40.00	24.68	Complied
69.19	V	14.86	40.00	25.14	Complied
453.73	H	21.65	46.00	24.35	Complied
679.95	V	26.62	46.00	19.38	Complied
897.91	H	30.95	46.00	15.05	Complied

**Plot: 30 MHz – 1GHz**

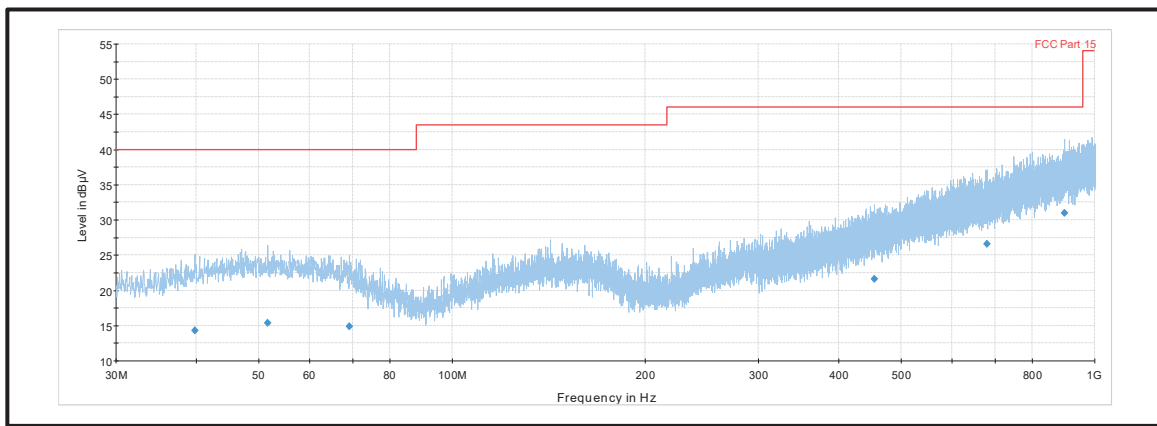

*Note: This plot is a pre-scan and for indication purposes only. For final measurements, see accompanying table.*

**Result: Pass**

**Transmitter Radiated Emissions (continued)**

**Test Summary:**

<b>Test Engineer:</b>	Segun Adeniji	<b>Test Date:</b>	18 May 2018
<b>Test Sample Serial Number:</b>	MS122017017612; MS122017015112; MS122017017112		
<b>Test Site Identification</b>	SR 1/2		

<b>FCC Reference:</b>	Parts 15.247(d) & 15.209(a)
<b>Test Method Used:</b>	FCC KDB 558074 Sections 11 & 12 referencing ANSI C63.10 Sections 6.3 and 6.6
<b>Frequency Range</b>	1 GHz to 25 GHz

**Environmental Conditions:**

<b>Temperature (°C):</b>	21
<b>Relative Humidity (%):</b>	41

**Note(s):**

1. The final measured value, for the given emission, in the table below incorporates the calibrated antenna factor and cable loss.
2. All the spurious emissions detected were re-investigated and re-measured with an average detector and in this case the emission was compared to the peak limit. For frequency range between 18 GHz and 25 GHz, no critical emission was found so only the measurement receiver noise floor level has been measured and recorded in the table The peak level was compared to the average limit as opposed to being compared to the peak limit because this is the more onerous limit. Only the middle channel plot was included in the report as similar result was obtained on both bottom and top channels.
3. The emission shown around the 2.4 GHz is the EUT fundamental.
4. Measurements above 1 GHz were performed in a semi-anechoic chamber at a distance of 3 metres. The EUT was placed at a height of 1.5 m above the reference ground plane in the centre of the chamber turntable. Maximum emission levels were determined by height searching the measurement antenna over the range 1 metre to 4 metres.
5. Pre-scans were performed and a marker placed on the highest measured level of the appropriate plot. The test receiver resolution bandwidth was set to 1 MHz and video bandwidth 3 MHz. The sweep time was set to auto.
6. \*In accordance with ANSI C63.10 Section 6.6.4.3, Note 1, if the peak measured value complies with the average limit, it is unnecessary to perform an average measurement.
7. The reference level for the emission in the non-restricted band was established by following KDB 558074 Section 11.2 procedure.

**Results:**

**Results: Peak / Bottom Channel**

Frequency (MHz)	Antenna Polarization	Level (dB $\mu$ V/m)	Limit (dB $\mu$ V/m)	Margin (dB)	Result
4803	Horizontal	58.66	74.0	15.34	Complied

**Results: Average / Bottom Channel**

Frequency (MHz)	Antenna Polarization	Level (dB $\mu$ V/m)	Limit (dB $\mu$ V/m)	Margin (dB)	Result
4803	Horizontal	51.43	54.0	2.57	Complied

**Results: Peak / Middle Channel**

Frequency (MHz)	Antenna Polarization	Level (dB $\mu$ V/m)	Limit (dB $\mu$ V/m)	Margin (dB)	Result
4852	Horizontal	53.13	74.0	20.87	Complied

**Results: Average / Middle Channel**

Frequency (MHz)	Antenna Polarization	Level (dB $\mu$ V/m)	Limit (dB $\mu$ V/m)	Margin (dB)	Result
4852	Horizontal	49.21	54.0	4.79	Complied

**Results: Peak / Top Channel**

Frequency (MHz)	Antenna Polarization	Level (dB $\mu$ V/m)	Limit (dB $\mu$ V/m)	Margin (dB)	Result
4959.67	Vertical	64.80	74.0	9.20	Complied

**Results: Average / Top Channel**

Frequency (MHz)	Antenna Polarization	Level (dB $\mu$ V/m)	Limit (dB $\mu$ V/m)	Margin (dB)	Result
4959.67	Vertical	53.57	54.0	0.43	Complied

Result: **Pass**

Plot: 1 GHz – 18GHz (Bottom channel) with Peak detector

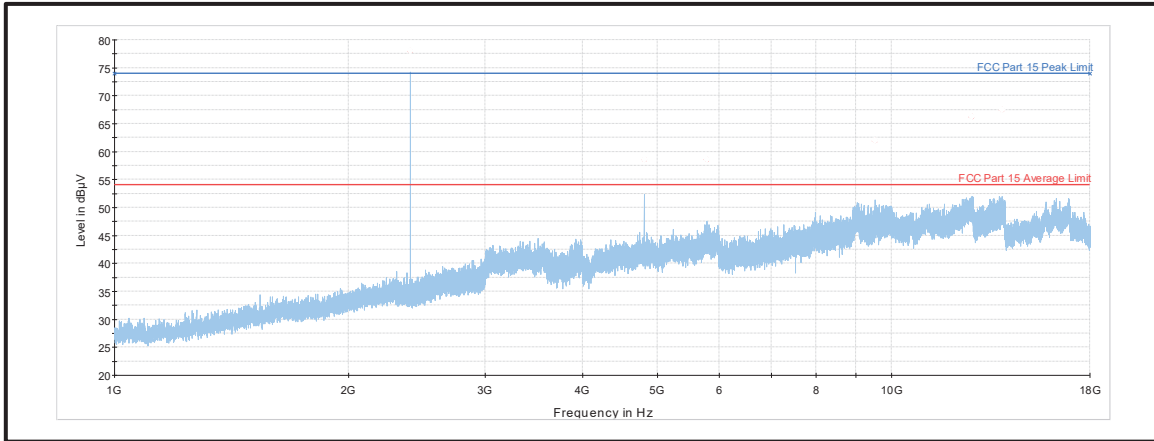

Plot: 1 GHz – 18GHz (Middle channel) with Peak detector

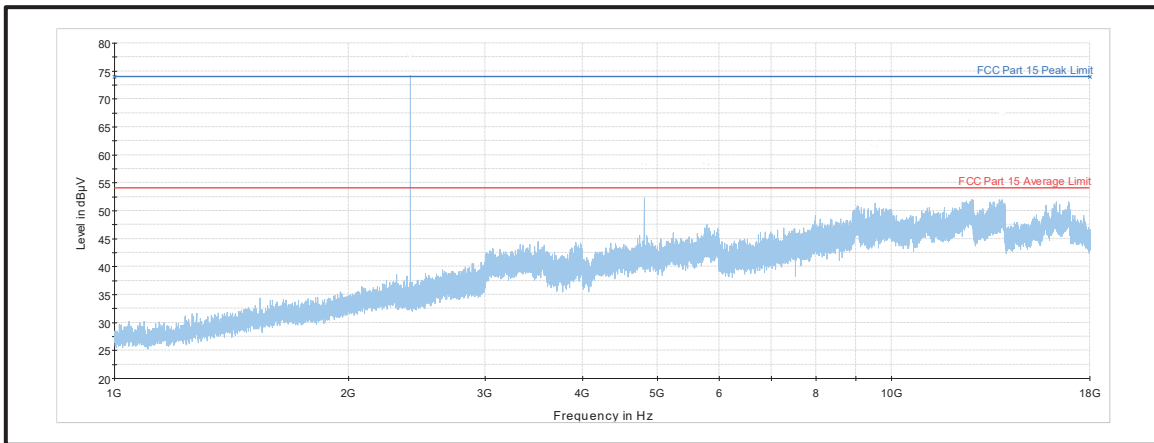

Plot: 1 GHz – 18GHz (Top channel) with Peak detector

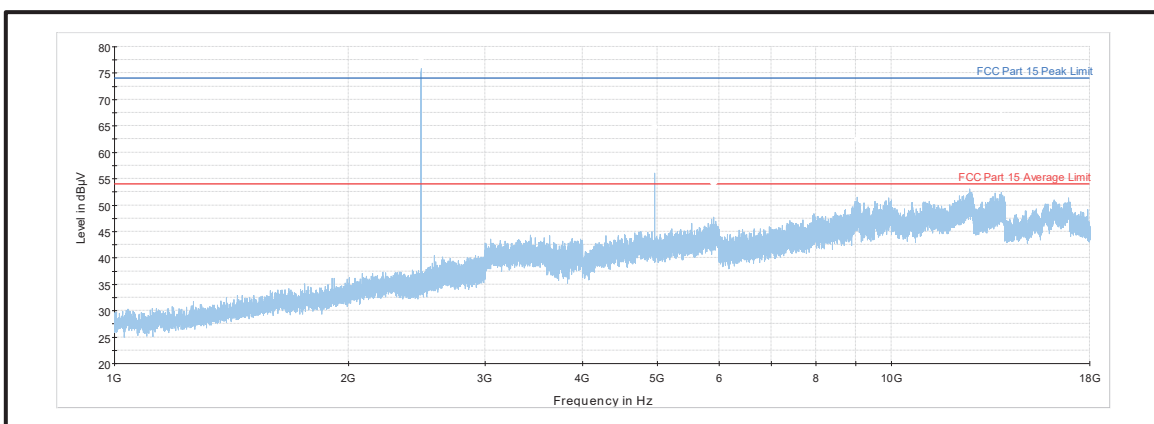

**Plot: 18 GHz – 25GHz (Middle channel) with Peak detector**

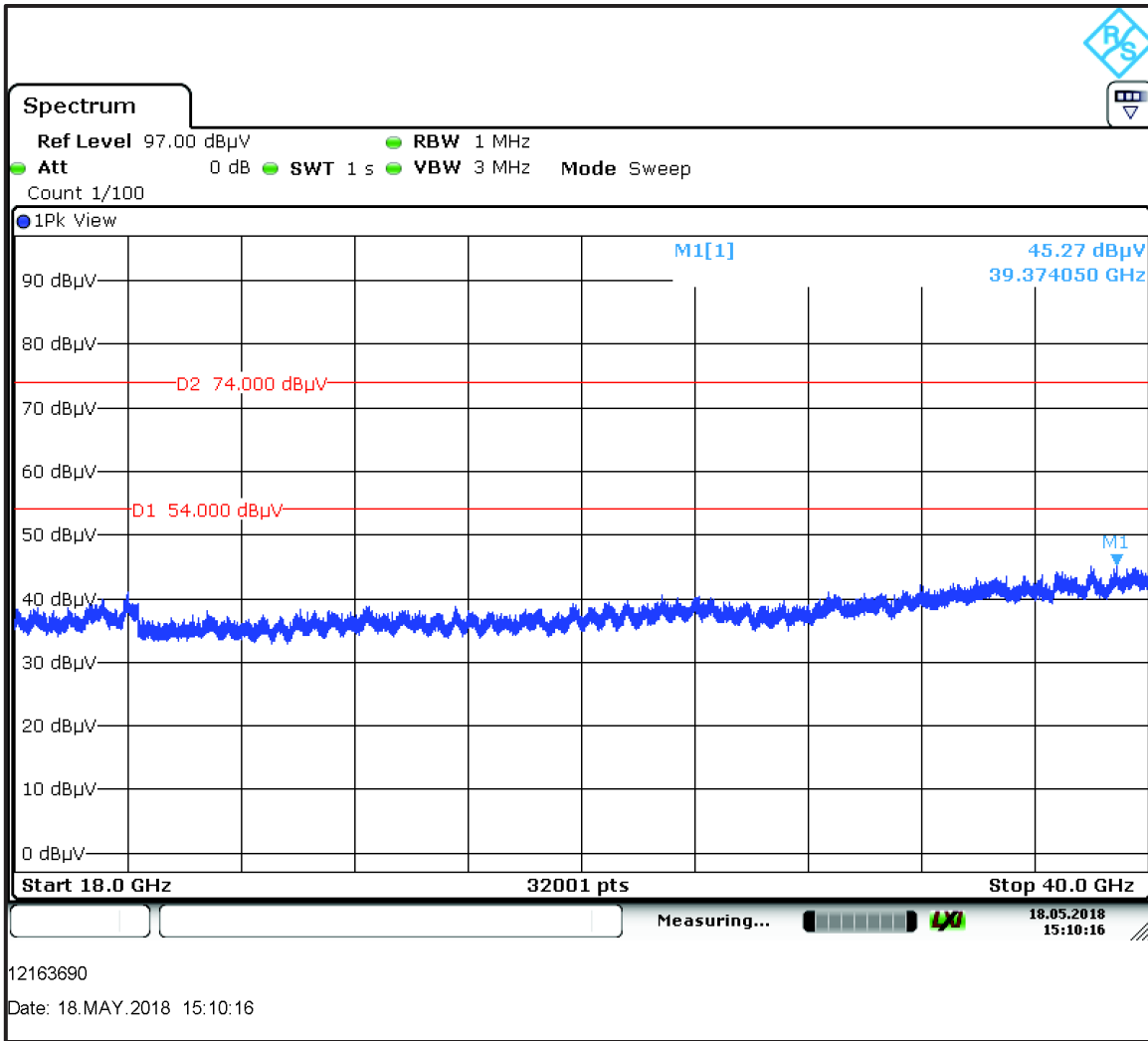

*Note: The above plots are pre-scans with peak detector and for indication purposes only.  
For final measurements, see accompanying tables.*

### **5.2.5. Transmitter Band Edge Radiated Emissions**

#### **Test Summary:**

<b>Test Engineer:</b>	Segun I. Adeniji	<b>Test Date:</b>	17 May 2018
<b>Test Sample Serial Number:</b>	MS122017017612; MS122017015112; MS122017017112		
<b>Test Site Identification</b>	SR 1/2		

<b>FCC Reference:</b>	Parts 15.247(d) & 15.209(a) & 15.209(b)
<b>Test Method Used:</b>	ANSI C63.10 Section 6.10.4, 6.10.5 & KDB 558074 Section 11

#### **Environmental Conditions:**

<b>Temperature (°C):</b>	21
<b>Relative Humidity (%):</b>	41

#### **Note(s):**

1. As the lower band edges fall within non-restricted bands, only peak measurements are required. In accordance with FCC KDB 558074 Section 11.1, the test method in Section 11.3 was followed: the test receiver resolution bandwidth was set to 100 kHz and video bandwidth 300 kHz. A peak detector was used, sweep time was set to auto and trace mode was Max Hold. The test receiver was left to sweep for a sufficient length of time in order to maximise the carrier level and out-of-band emissions. A marker and corresponding reference level line were placed on the peak of the carrier. As the maximum peak conducted output power was measured using a peak detector in accordance with FCC KDB 558074 Section 9.1.1 an out-of-band limit line was placed 20 dB below the peak level (FCC KDB 558074 Section 11.1(a)). A marker was placed on the band edge spot frequencies and a second marker placed on the highest emission level in the adjacent non-restricted band of operation (where a higher level emission was present). Marker frequencies and levels were recorded.
2. As the upper band edge falls within a restricted band both peak and average measurements were recorded by placing a marker at the edge of the band. For peak measurements the test receiver resolution bandwidth was set to 1 MHz and the video bandwidth 3 MHz. A peak detector was used, sweep time was set to auto and trace mode was Max Hold. For average measurements the test receiver resolution bandwidth was set to 1 MHz and the video bandwidth 3 MHz. An average detector was used, sweep time was set to auto and trace mode was Max Hold. The test receiver was left to sweep for a sufficient length of time in order to maximise the carrier level and out-of-band emissions. A marker was placed on the band edge spot frequencies and a second marker placed on the highest emission level in the adjacent restricted band of operation (where a higher level emission was present). Marker frequencies and levels were recorded.
3. There is a restricted band 10 MHz below the lower band edge. The test receiver was set up as follows: the RBW set to 1 MHz, the VBW set to 3 MHz, with the sweep time set to auto couple. Peak and average measurements were performed with their respective detectors. Markers were placed on the highest point on each trace.
4. \*Emissions in restricted bands: In accordance with C63.10 Section 6.6.4.3, Note 1, where the peak detected amplitude was shown to comply with the average limit, an average measurement was not performed.

**Test Setup:**

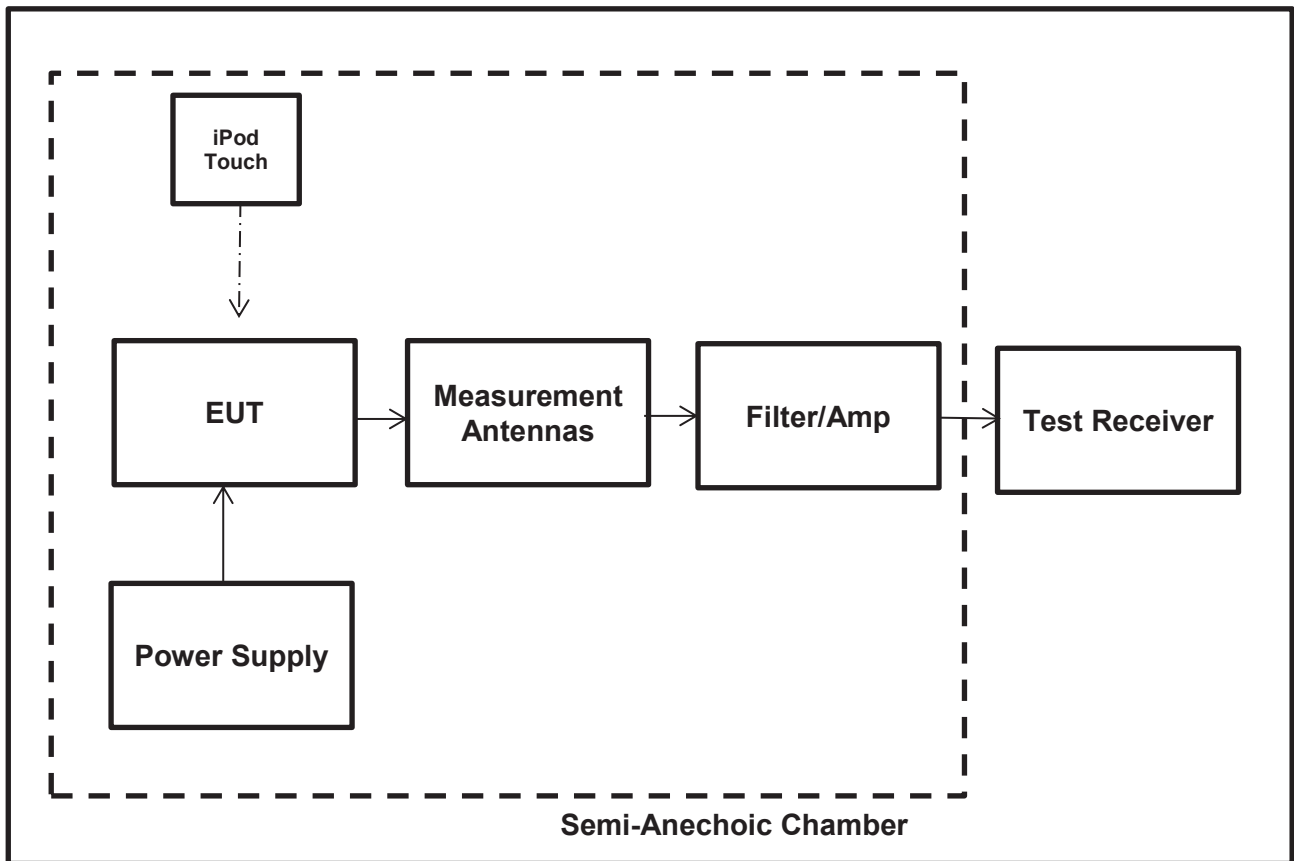

**Results: Lower Band Edge/Peak**

Frequency (MHz)	Level (dB $\mu$ V/m)	-20 dBc Limit (dB $\mu$ V/m)	Margin (dB)	Result
2400.000	75.47	97.51	22.04	Complied
2386.661	75.20	97.51	22.31	Complied

**Results: Upper Band Edge / Restricted Band / Peak**

Frequency (MHz)	Level (dB $\mu$ V/m)	Limit (dB $\mu$ V/m)	Margin (dB)	Result
2483.500	54.63	74.0	19.37	Complied

**Results: Upper Band Edge / Restricted Band / Average**

Frequency (MHz)	Average Level (dB $\mu$ V/m)	Limit (dB $\mu$ V/m)	Margin (dB)	Result
2483.500	47.45	54.0	6.55	Complied

**Results: 2310 to 2390 MHz Restricted Band / Peak**

Frequency (MHz)	Peak Level (dB $\mu$ V/m)	Limit (dB $\mu$ V/m)	Margin (dB)	Result
2364.62	57.02	74.0	16.98	Complied

**Results: 2310 to 2390 MHz Restricted Band / Average**

Frequency (MHz)	Average Level (dB $\mu$ V/m)	Limit (dB $\mu$ V/m)	Margin (dB)	Result
2334.45	47.77	54.0	6.23	Complied



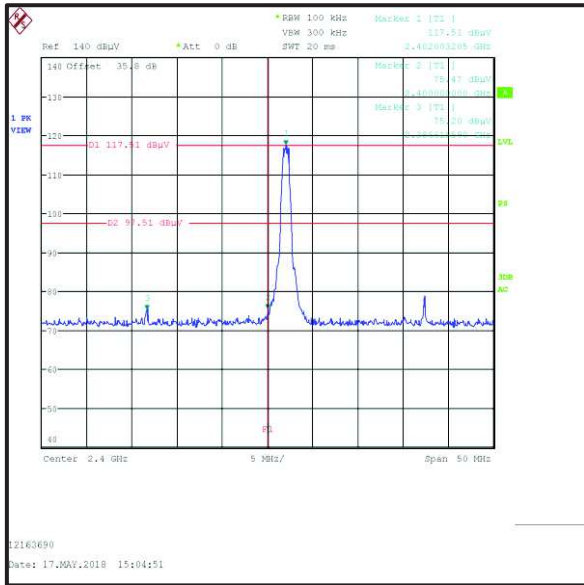

Lower Band Edge Peak Measurement

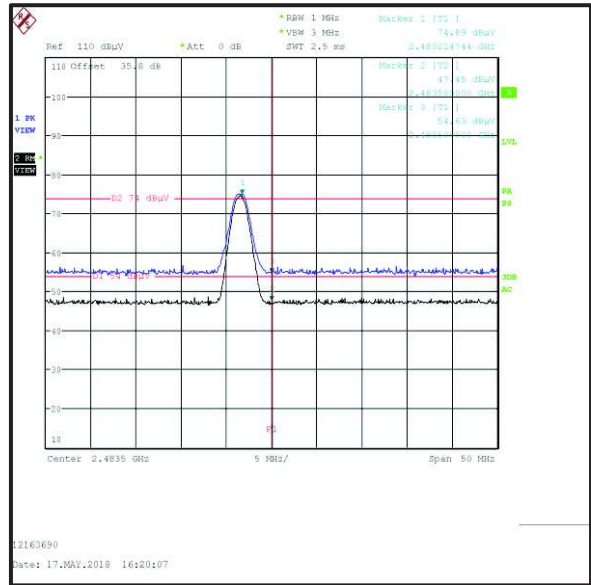

Upper Band Edge Peak Measurement

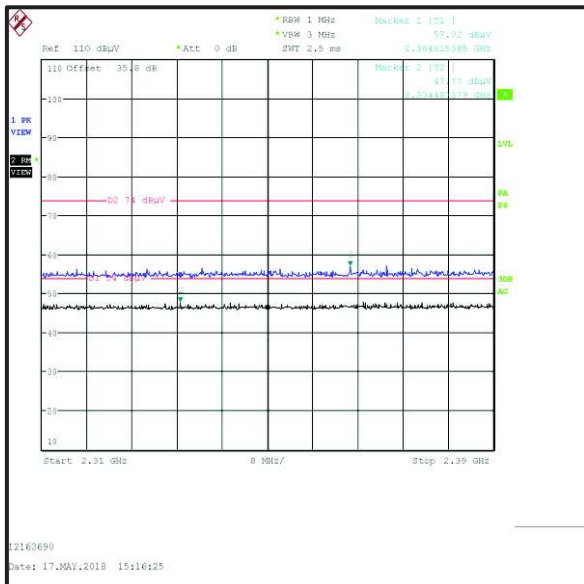

2310 MHz to 2390 MHz Restricted Band Plot

## 6. Measurement Uncertainty

The expression of uncertainty of a measurement result allows realistic comparison of results with reference values and limits given in specifications and standards.

The uncertainty of the result may need to be taken into account when interpreting the measurement results.

The reported expanded uncertainties below are based on a standard uncertainty multiplied by an appropriate coverage factor such that a confidence level of approximately 95% is maintained. For the purposes of this document “approximately” is interpreted as meaning “effectively” or “for most practical purposes”.

Measurement Type	Confidence Level (%)	Calculated Uncertainty
AC Conducted Spurious Emissions	95%	±2.49 dB
Conducted Maximum Peak Output Power	95%	±0.59 dB
Radiated Spurious Emissions	95%	±3.10 dB
Band Edge Radiated Emissions	95%	±3.10 dB
Minimum 6 dB Bandwidth	95%	±0.87 %

The methods used to calculate the above uncertainties are in line with those recommended within the various measurement specifications. Where measurement specifications do not include guidelines for the evaluation of measurement uncertainty the published guidance of the appropriate accreditation body is followed.

## 7. Used equipment

### Test site: SR 1/2

ID	Manufacturer	Type	Model	Serial No.	Calibration Date	Cal. Cycle
350	Rohde & Schwarz	Receiver, EMI Test	ESIB7	836697/014	7/13/2017	12
377	Bonn Elektronik	Amplifier, Low Noise Pre	BLMA 0118-1A	025294B	7/11/2017	12
423	Bonn Elektronik	Amplifier, Low Noise Pre	BLMA 1840-1A	055929	7/12/2017	12
460	Deisl	Turntable	DT 4250 S		n/a	n/a
465	Schwarzbeck	Antenna, Trilog Broadband	VULB 9168	9168-240	8/8/2016	36
496	Rohde & Schwarz	Antenna, log. - periodical	HL050	100297	7/20/2016	24
587	Maturo	antenna mast, tilting	TAM 4.0-E	011/7180311	n/a	n/a
588	Maturo	Controller	NCD	029/7180311	n/a	n/a
591	Rohde & Schwarz	Receiver	ESU 40	100244/040	7/12/2017	12
608	Rohde & Schwarz	Switch Matrix	OSP 120	101227	4/8/2014	60
614	Wainwright Instruments	Highpass Filter 3GHz	WHKX10-	1	Lab verification	n/a
615	Wainwright Instruments	Highpass Filter 1GHz	WHKX12-	3	Lab verification	n/a
620	Bonn Elektronik	pre-amplifier	BLNA 0110-01N	1510111	7/12/2017	24
628	Maturo	Antenna mast	CAM 4.0-P	224/19590716	n/a	n/a
629	Maturo	Kipheinrichtung	KE 2.5-R-M	MAT002	n/a	n/a

### Test site: SR 9

ID	Manufacturer	Type	Model	Serial No.	Calibration Date	Cal. Cycle
634	Rohde & Schwarz	Wireless Devices Test System	TS8997		7/11/2017	12
636	Rohde & Schwarz	switching unit	OSP120	101698	7/14/2017	12
637	Rohde & Schwarz	Spectrum Analyzer	FSV40	101587	7/11/2017	12
195	SPS	Power Supply	TOE8842-24	51455	Verified by Multimeter	12
216	Agilent	Multimeter	34401A	US36017458	7/11/2017	24

### Test site: SR 7/8

ID	Manufacturer	Type	Model	Serial No.	Calibration Date	Cal. Cycle
22	Rohde & Schwarz	Artificial Mains	50 Ohm// 50uH	831767/014	7/12/2017	12
215	Rohde & Schwarz	Artificial Mains Network	9 kHz - 30 MHz; 3 phase	879675/002	7/12/2017	12
350	Rohde & Schwarz	Receiver, EMI Test	20 Hz - 7 GHz	836697/014	7/13/2017	12
616	Rohde & Schwarz	ISN	8 wire ISN for CAT6	101656	7/13/2017	12

## **8. Report Revision History**

Version Number	Revision Details		
	Page No(s)	Clause	Details
1.0	-	-	Initial Version