



TEST REPORT

Test Report No. : UL-RPT-RP-12163690-516-FCC

Applicant : Healthup Sp.z. o.o.
Model : AioCare 12/2017
FCC ID : 2AP4V-AIOCARE
Technology : Bluetooth – Low Energy
Test Standard(s) : FCC Parts 15.207, 15.209 & 15.247

For details of applied tests refer to test result summary

1. This test report shall not be reproduced in full or partial, without the written approval of UL International Germany GmbH.
2. The results in this report apply only to the sample tested.
3. The test results in this report are traceable to the national or international standards.
4. Test Report Version 1.0
5. Result of the tested sample: **PASS**

Prepared by: Segun I. Adeniji
Title: Engineer
Date: 18.September.2018

Approved by: Ajit, Phadtare
Title: Lead Test Engineer
Date: 18.September.2018



Deutsche
Akkreditierungsstelle
D-PL-19381-02-00

This laboratory is accredited by DAkkS.
The tests reported herein have been performed in
accordance with its' terms of accreditation.

This page has been left intentionally blank.

Table of Contents

| | |
|--|-----------|
| 1. Customer Information..... | 4 |
| 1.1.Applicant Information | 4 |
| 1.2.Manufacturer Information | 4 |
| 2. Summary of Testing..... | 5 |
| 2.1. General Information | 5 |
| Applied Standards | 5 |
| Location | 5 |
| Date information | 5 |
| 2.2. Summary of Test Results | 6 |
| 2.3. Methods and Procedures | 6 |
| 2.4. Deviations from the Test Specification | 6 |
| 3. Equipment Under Test (EUT) | 7 |
| 3.1. Identification of Equipment Under Test (EUT) | 7 |
| 3.2. Description of EUT | 9 |
| 3.3. Modifications Incorporated in the EUT | 9 |
| 3.4. Additional Information Related to Testing | 10 |
| 3.5. Support Equipment | 10 |
| A. Support Equipment (In-house) | 10 |
| B. Support Equipment (Manufacturer supplied) | 10 |
| 4. Operation and Monitoring of the EUT during Testing | 11 |
| 4.1. Operating Modes | 11 |
| 4.2. Configuration and Peripherals | 11 |
| 5. Measurements, Examinations and Derived Results | 12 |
| 5.1. General Comments | 12 |
| 5.2. Test Results | 13 |
| 5.2.1. Transmitter AC Conducted Spurious Emissions | 13 |
| 5.2.2. Transmitter Minimum 6 dB Bandwidth | 17 |
| 5.2.3. Transmitter Maximum Peak Output Power | 19 |
| 5.2.4. Transmitter Radiated Emissions | 23 |
| 5.2.5. Transmitter Band Edge Radiated Emissions | 30 |
| 6. Measurement Uncertainty | 34 |
| 7. Used equipment..... | 35 |
| 8. Report Revision History | 36 |

1. Customer Information

1.1.Applicant Information

| | |
|---------------------------|--|
| Company Name: | Healthup Sp. z o.o. |
| Company Address: | Smolna street 4, 00-375 Warsaw, POLAND |
| Company Phone No.: | +48601135486 |
| Company E-Mail: | marta@healthup.pl |
| Contact Person: | Marta Kuznicka |

1.2.Manufacturer Information

| | |
|---------------------------|--|
| Company Name: | Healthup Sp. z o.o. |
| Company Address: | Smolna street 4, 00-375 Warsaw, POLAND |
| Company Phone No.: | +48601135486 |
| Company E-Mail: | marta@healthup.pl |
| Contact Person: | Marta Kuznicka |

2. Summary of Testing

2.1. General Information

Applied Standards

| | |
|---------------------------------|---|
| Specification Reference: | 47CFR15.247 |
| Specification Title: | Code of Federal Regulations Volume 47 (Telecommunications): Part 15 Subpart C (Intentional Radiators) - Section 15.247 |
| Specification Reference: | 47CFR15.207 and 47CFR15.209 |
| Specification Title: | Code of Federal Regulations Volume 47 (Telecommunications): Part 15 Subpart C (Intentional Radiators) - Sections 15.207 and 15.209 |
| Test Firm Registration: | 399704 |

Location

| | |
|-----------------------------|--|
| Location of Testing: | UL International Germany GmbH Hedelfinger Str. 61 70327 Stuttgart Germany |
|-----------------------------|--|

Date information

| | |
|----------------------|----------------------|
| Order Date: | 31 January 2018 |
| EUT arrived: | 10 May 2018 |
| Test Dates: | 17 May – 29 May 2018 |
| EUT returned: | -/- |

2.2. Summary of Test Results

| Clause | Measurement | Complied | Did not comply | Not performed | Not applicable |
|--------------------------|--|-------------------------------------|--------------------------|--------------------------|-------------------------------------|
| Part 15.207 | Transmitter AC Conducted Emissions | <input checked="" type="checkbox"/> | <input type="checkbox"/> | <input type="checkbox"/> | <input type="checkbox"/> |
| Part 15.247(a)(2) | Transmitter Minimum 6 dB Bandwidth | <input checked="" type="checkbox"/> | <input type="checkbox"/> | <input type="checkbox"/> | <input type="checkbox"/> |
| Part 15.247(e) | Transmitter Power Spectral Density | <input type="checkbox"/> | <input type="checkbox"/> | <input type="checkbox"/> | <input checked="" type="checkbox"/> |
| Part 15.247(b)(3) | Transmitter Maximum Peak Output Power | <input checked="" type="checkbox"/> | <input type="checkbox"/> | <input type="checkbox"/> | <input type="checkbox"/> |
| Part 15.247(d)/15.209(a) | Transmitter Radiated Emissions | <input checked="" type="checkbox"/> | <input type="checkbox"/> | <input type="checkbox"/> | <input type="checkbox"/> |
| Part 15.247(d)/15.209(a) | Transmitter Band Edge Radiated Emissions | <input checked="" type="checkbox"/> | <input type="checkbox"/> | <input type="checkbox"/> | <input type="checkbox"/> |

Note(s):

1. In accordance with FCC KDB 558074 Section 10.1, PSD is not required if the maximum conducted output power is less than the PSD limit of 8 dBm / 3 kHz. The PSD level is therefore deemed to be equal to the measured total output power.

2.3. Methods and Procedures

| | |
|-------------------|---|
| Reference: | ANSI C63.10-2013 |
| Title: | American National Standard of Procedures for Compliance Testing of Unlicensed Wireless Devices |
| Reference: | KDB 558074 D01 DTS Meas Guidance v04 April 5, 2017 |
| Title: | Guidance for Performing Compliance Measurements on Digital Transmission Systems (DTS) Operating Under §15.247 |
| Reference: | KDB 174176 D01 Line Conducted FAQ v01r01 June 3, 2015 |
| Title: | AC Power-Line Conducted Emissions Frequently Asked Questions |

2.4. Deviations from the Test Specification

For the measurements contained within this test report, there were no deviations from, additions to, or exclusions from the test specification identified above.

3. Equipment Under Test (EUT)

3.1. Identification of Equipment Under Test (EUT)

| | |
|-----------------------------------|--|
| Brand Name: | AioCare |
| Model Name or Number: | 12/2017 |
| Test Sample Serial Number: | Bottom Channel: MS082017007812 (<i>Conducted Sample</i>) |
| Hardware Version Number: | 1.7.2 |
| Software Version Number: | 2.0.0 |
| FCC ID: | 2AP4V-AIOCARE |

| | |
|-----------------------------------|--|
| Brand Name: | AioCare |
| Model Name or Number: | 12/2017 |
| Test Sample Serial Number: | Middle Channel: MS122017007912 (<i>Conducted Sample</i>) |
| Hardware Version Number: | 1.7.2 |
| Software Version Number: | 2.0.0 |
| FCC ID: | 2AP4V-AIOCARE |

| | |
|-----------------------------------|---|
| Brand Name: | AioCare |
| Model Name or Number: | 12/2017 |
| Test Sample Serial Number: | Top Channel: MS122017001112 (<i>Conducted Sample</i>) |
| Hardware Version Number: | 1.7.2 |
| Software Version Number: | 2.0.0 |
| FCC ID: | 2AP4V-AIOCARE |

| | |
|-----------------------------------|---|
| Brand Name: | AioCare |
| Model Name or Number: | 12/2017 |
| Test Sample Serial Number: | Bottom Channel: MS122017017612 (<i>Radiated Sample</i>) |
| Hardware Version Number: | 1.7.2 |
| Software Version Number: | 2.0.0 |
| FCC ID: | 2AP4V-AIOCARE |

| | |
|-----------------------------------|---|
| Brand Name: | AioCare |
| Model Name or Number: | 12/2017 |
| Test Sample Serial Number: | Middle Channel: MS122017015112 (<i>Radiated Sample</i>) |
| Hardware Version Number: | 1.7.2 |
| Software Version Number: | 2.0.0 |
| FCC ID: | 2AP4V-AIOCARE |

| | |
|-----------------------------------|--|
| Brand Name: | AioCare |
| Model Name or Number: | 12/2017 |
| Test Sample Serial Number: | Top Channel: MS122017017112 (<i>Radiated Sample</i>) |
| Hardware Version Number: | 1.7.2 |
| Software Version Number: | 2.0.0 |
| FCC ID: | 2AP4V-AIOCARE |

3.2. Description of EUT

The equipment under test was a spirometer supporting Bluetooth Low energy communications & Wireless Power Transfer (WPT) charging.

3.3. Modifications Incorporated in the EUT

No modifications were applied to the EUT during testing.

3.4. Additional Information Related to Testing

| | | | |
|-------------------------------------|--|-------------------|--------------------------------|
| Technology Tested: | Bluetooth Low Energy (Digital Transmission System) | | |
| Type of Unit: | Transceiver | | |
| Channel Spacing: | 2 MHz | | |
| Modulation: | GFSK | | |
| Data Rate: | 1 Mbps | | |
| Power Supply Requirement(s): | Nominal | 3.5 VDC - 4.2 VDC | |
| Antenna Designation: | 2450AT18B100E | | |
| Antenna Type: | High Frequency Ceramic Antenna | | |
| Antenna Gain: | 0.5 dBi (Peak) | | |
| Transmit Frequency Range: | 2402 MHz to 2480 MHz | | |
| Transmit Channels Tested: | Channel ID | RF Channel | Channel Frequency (MHz) |
| | Bottom | 0 | 2402 |
| | Middle | 19 | 2440 |
| | Top | 39 | 2480 |

3.5. Support Equipment

The following support equipment was used to exercise the EUT during testing:

A. Support Equipment (In-house)

| Item | Description | Brand Name | Model Name or Number | Serial Number |
|------|-------------------|------------|----------------------|---------------|
| 1 | USB AC/DC Adaptor | Samsung | - | DW4D520DS/B-E |

B. Support Equipment (Manufacturer supplied)

| Item | Description | Brand Name | Model Name or Number | Serial Number |
|------|--------------------------------------|------------|----------------------|---------------|
| 1 | 1.5m USB Charging Cable with Ferrite | Sony | Not Stated | Not Stated |

4. Operation and Monitoring of the EUT during Testing

4.1. Operating Modes

The EUT was tested in the following operating mode(s):

Transmitting at maximum power in *Bluetooth* LE mode with modulation, maximum possible data length.

Idle Mode

4.2. Configuration and Peripherals

The EUT was tested in the following configuration(s):

- The EUT was powered via the fully charged internal battery integrated within the EUT.
- The manufacturer has set the all EUTs to transmit at the highest output power.
- The EUT conducted samples were used for 6 dB bandwidth, 99% emission bandwidth, power spectral density and maximum peak output power measurements.
- Each conducted EUT sample was supplied with a short length of RF cable attached to the antenna connector in order to support RF conducted test measurements. This cable introduced a loss of 1dB @ 2400MHz. This has been taken in to account with the measured conducted values.”
- The EUT radiated samples were used for AC conducted emissions and radiated spurious emissions measurements.

5. Measurements, Examinations and Derived Results

5.1. General Comments

Measurement uncertainties are evaluated in accordance with current best practice. Our reported expanded uncertainties are based on standard uncertainties, which are multiplied by an appropriate coverage factor to provide a statistical confidence level of approximately 95%. Please refer to Section 6 *Measurement Uncertainty* for details.

In accordance with DAkkS requirements all the measurement equipment is on a calibration schedule. All equipment was within the calibration period on the date of testing.

5.2. Test Results

5.2.1. Transmitter AC Conducted Spurious Emissions

Test Summary:

| | | | |
|-----------------------------------|----------------|-------------------|------------|
| Test Engineer: | Asim | Test Date: | 29.05.2018 |
| Test Sample Serial Number: | MS122017015112 | | |
| Test Site Identification | SR 7/8 | | |

| | |
|---------------------|--|
| Clause: | Part 15.207 |
| Test Method: | ANSI C63.10 Section 6.2 / FCC KDB 174176 and notes below |

Environmental Conditions:

| | |
|-------------------------------|----|
| Temperature (°C): | 20 |
| Relative Humidity (%): | 38 |

Settings of the Instrument

| | |
|-----------------|--------------------------|
| Detector | Quasi Peak/ Average Peak |
|-----------------|--------------------------|

Note(s):

1. The EUT was connected to an AC/DC Adaptor.
2. The EUT Adaptor was connected to a 120 VAC 60 Hz single phase supply via a LISN.
3. The final measured value, for the given emission, in the table below incorporates the cable loss.
4. All other emissions shown on the pre-scan plot were investigated and found to be ambient or >20 dB below the applicable limit or below the measurement system noise floor.
5. Measurements were performed in shielded room (SR7/ 8 Asset Number 1603671). The EUT was placed at a height of 80 cm above the reference ground plane and in a distance of 40 cm from the vertical ground plane at the edge of the table.

Transmitter AC Conducted Spurious Emissions (continued)

Test setup:

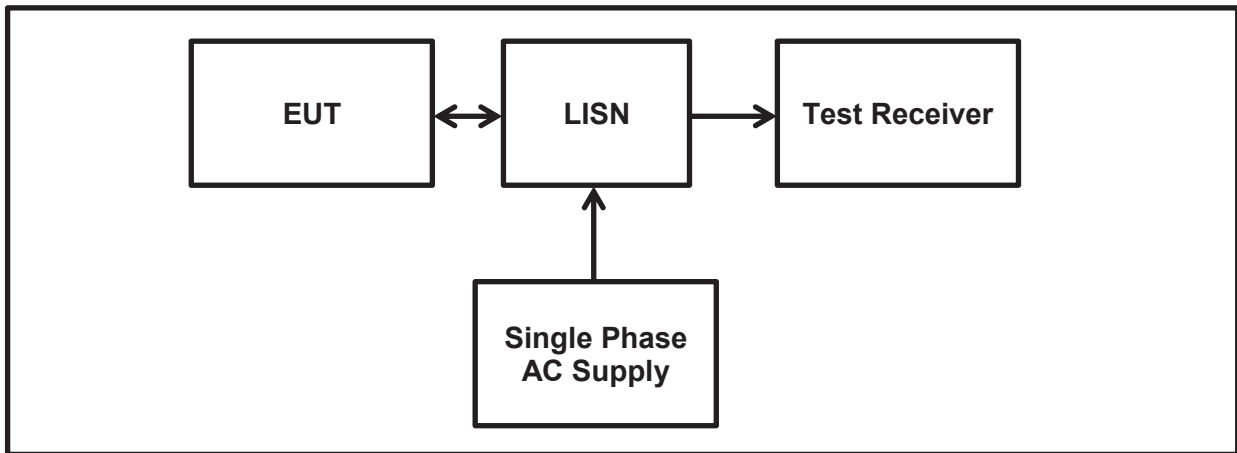

Results: Live / Quasi Peak / 120 VAC 60 Hz

| Frequency (MHz) | Line | Level (dB μ V) | Limit (dB μ V) | Margin (dB) | Result |
|-----------------|------|--------------------|--------------------|-------------|----------|
| 0.43128 | Live | 24.4 | 57.2 | 32.8 | Complied |
| 0.74829 | Live | 32.3 | 56 | 23.7 | Complied |
| 1.27156 | Live | 25.6 | 56 | 30.4 | Complied |
| 3.16451 | Live | 22.5 | 56 | 33.5 | Complied |
| 5.84802 | Live | 20.9 | 60 | 39.1 | Complied |
| 18.76675 | Live | 29 | 60 | 31 | Complied |

Results: Live / Average / 120 VAC 60 Hz

| Frequency (MHz) | Line | Level (dB μ V) | Limit (dB μ V) | Margin (dB) | Result |
|-----------------|------|--------------------|--------------------|-------------|----------|
| 0.43128 | Live | 12.6 | 47.2 | 34.6 | Complied |
| 0.74829 | Live | 18.8 | 46 | 27.2 | Complied |
| 1.27156 | Live | 13 | 46 | 33 | Complied |
| 3.16451 | Live | 9.9 | 46 | 36.1 | Complied |
| 5.84802 | Live | 9.4 | 50 | 40.6 | Complied |
| 18.76675 | Live | 15.9 | 50 | 34.1 | Complied |

Results: Neutral / Quasi Peak / 120 VAC 60 Hz

| Frequency (MHz) | Line | Level (dB μ V) | Limit (dB μ V) | Margin (dB) | Result |
|-----------------|---------|--------------------|--------------------|-------------|----------|
| 0.25074 | Neutral | 25.5 | 61.7 | 36.2 | Complied |
| 0.52361 | Neutral | 23.7 | 56 | 32.3 | Complied |
| 0.74551 | Neutral | 32.5 | 56 | 23.5 | Complied |
| 1.35743 | Neutral | 23.1 | 56 | 32.9 | Complied |
| 2.24603 | Neutral | 23.9 | 56 | 32.1 | Complied |
| 19.19806 | Neutral | 29.2 | 60 | 30.8 | Complied |

Results: Neutral / Average / 120 VAC 60 Hz

| Frequency (MHz) | Line | Level (dB μ V) | Limit (dB μ V) | Margin (dB) | Result |
|-----------------|---------|--------------------|--------------------|-------------|----------|
| 0.25074 | Neutral | 14.3 | 51.7 | 37.4 | Complied |
| 0.52361 | Neutral | 10.8 | 46 | 35.2 | Complied |
| 0.74551 | Neutral | 16.9 | 46 | 29.1 | Complied |
| 1.35743 | Neutral | 10.4 | 46 | 35.6 | Complied |
| 2.24603 | Neutral | 9.9 | 46 | 36.1 | Complied |
| 19.19806 | Neutral | 14.4 | 50 | 35.6 | Complied |

Result: Pass

Plot: Live and Neutral Line

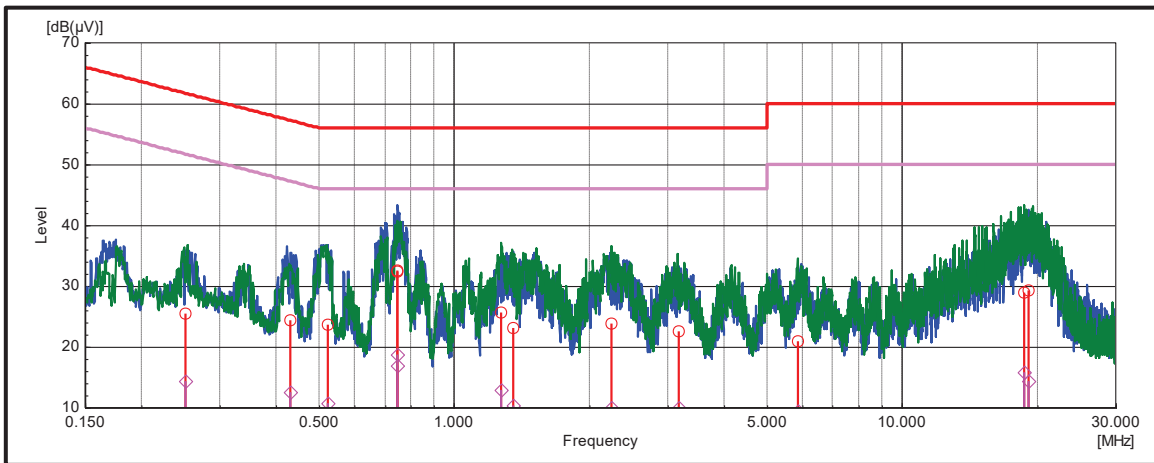

Note: These plots are pre-scans and for indication purposes only. For final measurements, see accompanying tables.

5.2.2. Transmitter Minimum 6 dB Bandwidth

Test Summary:

| | | | |
|-----------------------------------|--|-------------------|-------------|
| Test Engineer: | Segun Adeniji | Test Date: | 18 May 2018 |
| Test Sample Serial Number: | MS082017007812, MS122017007912, MS122017001112 | | |
| Test Site Identification | SR 9 | | |

| | |
|--------------------------|-------------------------------------|
| FCC Reference: | Part 15.247(a)(2) |
| Test Method Used: | FCC KDB 558074 Section 8.1 Option 1 |

Environmental Conditions:

| | |
|-------------------------------|----|
| Temperature (°C): | 23 |
| Relative Humidity (%): | 33 |

Note(s):

1. 6 dB DTS bandwidth tests were performed using a spectrum analyser in accordance with FCC KDB 558074 Section 8.1 Option 1 measurement procedure. The spectrum analyser resolution bandwidth was set to 100 kHz and video bandwidth 300 kHz. A peak detector was used, sweep time was set to auto and the trace mode was Max Hold. The DTS bandwidth was measured at 6 dB down from the peak of the signal.
2. The spectrum analyser was connected to the RF port on the EUT using suitable attenuation and RF cable.

Test Setup:

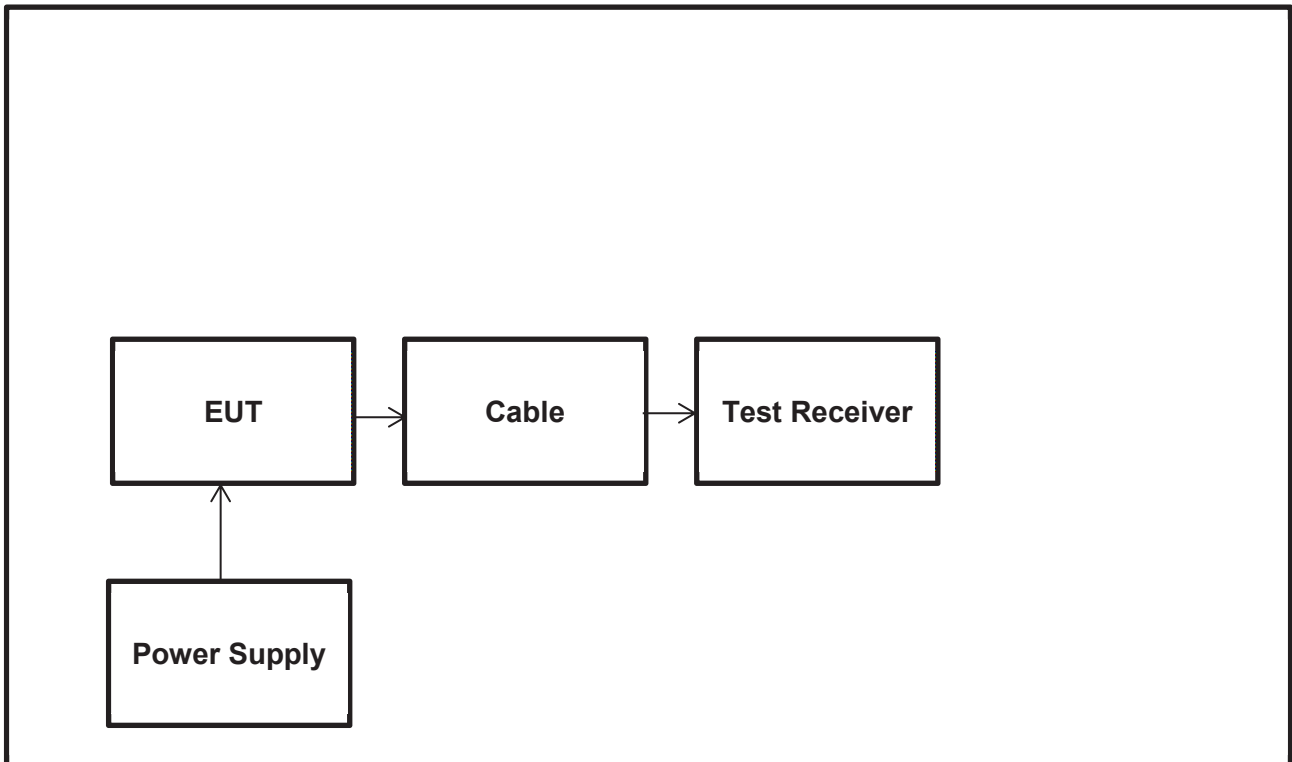

Results:

| Channel | 6 dB Bandwidth (kHz) | Limit (kHz) | Margin (kHz) | Result |
|---------|----------------------|-------------|--------------|----------|
| Bottom | 752.476 | ≥500 | 252.476 | Complied |
| Middle | 752.476 | ≥500 | 252.476 | Complied |
| Top | 752.476 | ≥500 | 252.476 | Complied |

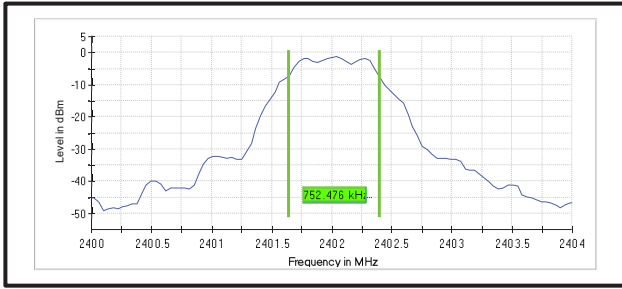

Bottom Channel

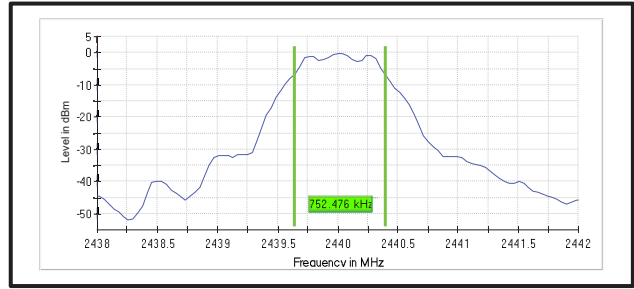

Middle Channel

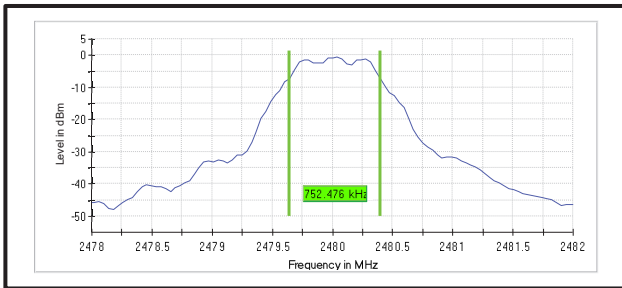

Top Channel

Result: Pass

System Measurement Settings:

| Setting | Instrument Value | Target Value |
|-----------------------|------------------|---------------|
| Start Frequency | 2.43800 GHz | 2.43800 GHz |
| Stop Frequency | 2.44200 GHz | 2.44200 GHz |
| Span | 4.000 MHz | 4.000 MHz |
| RBW | 100.000 kHz | ~ 100.000 kHz |
| VBW | 300.000 kHz | ~ 300.000 kHz |
| SweepPoints | 101 | ~ 40 |
| SweepTime | 18.938 μs | AUTO |
| Reference Level | -10.000 dBm | -10.000 dBm |
| Attenuation | 10.000 dB | AUTO |
| Detector | MaxPeak | MaxPeak |
| SweepCount | 100 | 100 |
| Filter | 3 dB | 3 dB |
| Trace Mode | Max Hold | Max Hold |
| Sweeptype | FFT | AUTO |
| Preamp | off | off |
| Stablemode | Trace | Trace |
| Stablevalue | 0.50 dB | 0.50 dB |
| Run | 13 / max. 150 | max. 150 |
| Stable | 5 / 5 | 5 |
| Max Stable Difference | 0.00 dB | 0.50 dB |

5.2.3. Transmitter Maximum Peak Output Power

Test Summary:

| | | | |
|-----------------------------------|--|-------------------|-------------|
| Test Engineer: | Segun Adeniji | Test Date: | 18 May 2018 |
| Test Sample Serial Number: | MS082017007812, MS122017007912, MS122017001112 | | |
| Test Site Identification | SR 9 | | |

| | |
|--------------------------|------------------------------|
| FCC Reference: | Part 15.247(b)(3) |
| Test Method Used: | FCC KDB 558074 Section 9.1.1 |

Environmental Conditions:

| | |
|-------------------------------|----|
| Temperature (°C): | 23 |
| Relative Humidity (%): | 34 |

Note(s):

1. Conducted power tests were performed using a spectrum analyser in accordance with FCC KDB 558074 Section 9.1.1 with the RBW > *DTS bandwidth* procedure.
2. The signal analyser resolution bandwidth was set to 3 MHz and video bandwidth of 10 MHz. A peak detector was used, sweep time was set to auto and trace mode was Max Hold. The span was set to 9 MHz. A marker was placed at the peak of the signal and the results recorded in the table below.
3. The spectrum analyser was connected to the RF port on the EUT using suitable attenuation and RF cable. An RF level offset was entered on the spectrum analyser to compensate for the loss of the attenuator and RF cable.
4. The measurement was made with highest possible duty cycle
5. The conducted power was added to the declared antenna gain to obtain the EIRP.

Test setup:

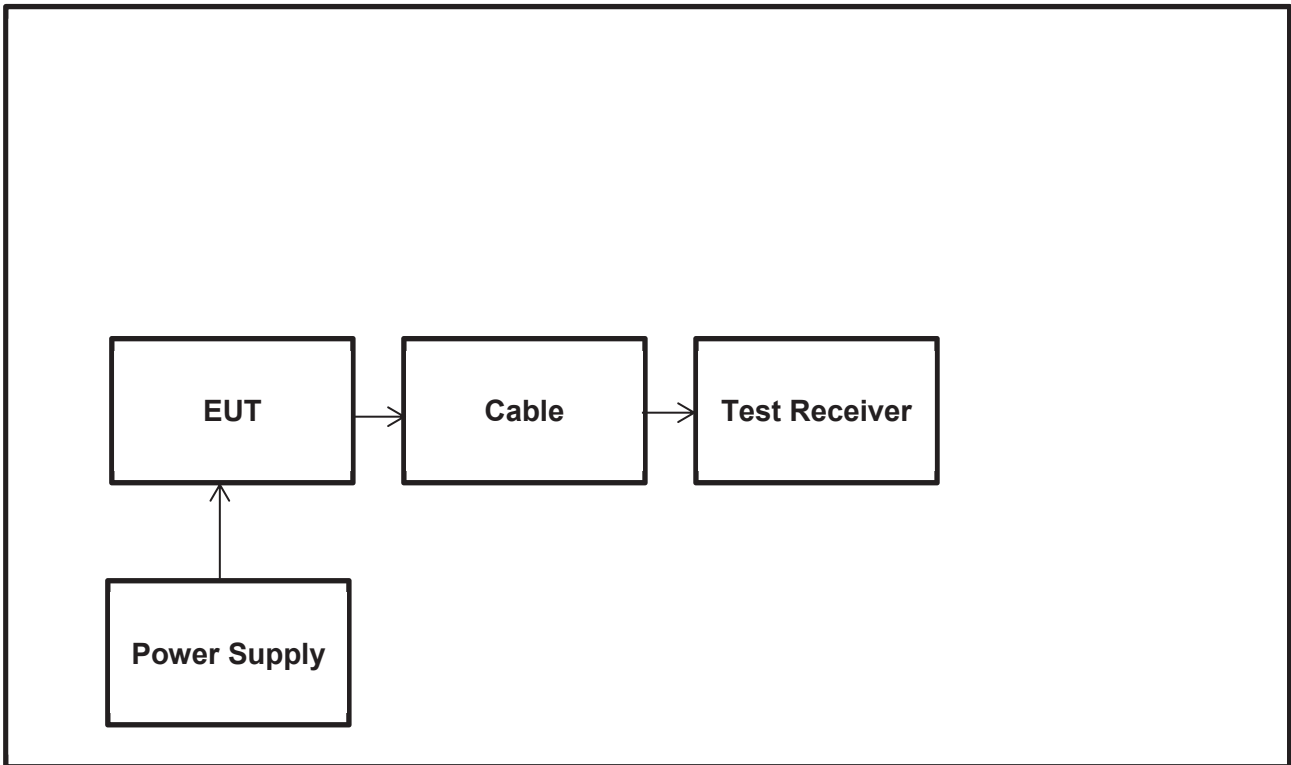

Results:

| Channel | Measured Conducted Peak Power (dBm) | Cable Loss (dB) | Effective Conducted Peak Power (dBm) | Conducted Peak Power Limit (dBm) | Margin (dB) | Result |
|---------|-------------------------------------|-----------------|--------------------------------------|----------------------------------|-------------|----------|
| Bottom | -0.8 | 1.0 | 0.2 | 30.0 | 29.8 | Complied |
| Middle | -0.1 | 1.0 | 0.9 | 30.0 | 29.1 | Complied |
| Top | -0.5 | 1.0 | 0.5 | 30.0 | 29.5 | Complied |

| Channel | Conducted Peak Power (dBm) | Declared Antenna Gain (dBi) | EIRP (dBm) | De Facto EIRP Limit (dBm) | Margin (dB) | Result |
|---------|----------------------------|-----------------------------|------------|---------------------------|-------------|----------|
| Bottom | 0.2 | 0.5 | 0.7 | 36.0 | 35.3 | Complied |
| Middle | 0.9 | 0.5 | 1.4 | 36.0 | 34.6 | Complied |
| Top | 0.5 | 0.5 | 1.0 | 36.0 | 35.0 | Complied |

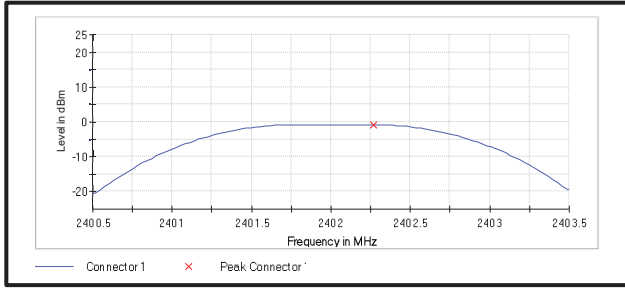

Bottom Channel

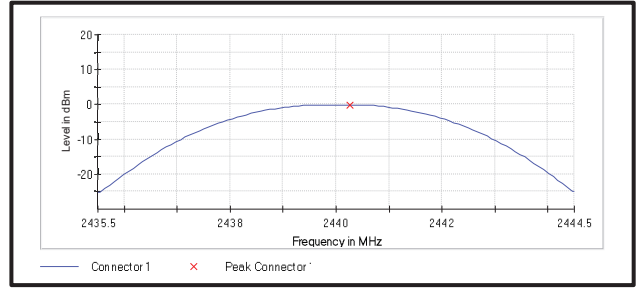

Middle Channel

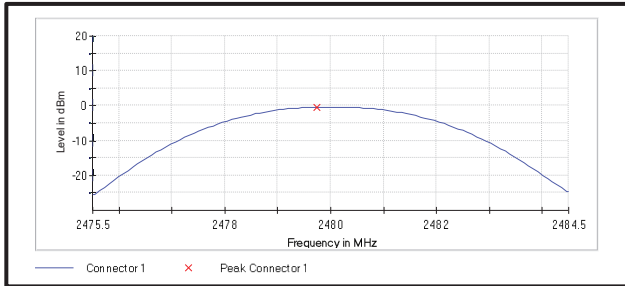

Top Channel

Result: Pass

System Measurement Settings:

| Setting | Instrument Value | Target Value |
|-----------------------|------------------|--------------|
| Start Frequency | 2.43550 GHz | 2.43550 GHz |
| Stop Frequency | 2.44450 GHz | 2.44450 GHz |
| Span | 9.000 MHz | 9.000 MHz |
| RBW | 3.000 MHz | >= 3.000 MHz |
| VBW | 10.000 MHz | >= 9.000 MHz |
| SweepPoints | 101 | ~ 101 |
| Sweeptime | 1.271 µs | AUTO |
| Reference Level | 10.000 dBm | 10.000 dBm |
| Attenuation | 30.000 dB | AUTO |
| Detector | MaxPeak | MaxPeak |
| SweepCount | 100 | 100 |
| Filter | 3 dB | 3 dB |
| Trace Mode | Max Hold | Max Hold |
| Sweeptype | FFT | AUTO |
| Preamp | off | off |
| Stablemode | Trace | Trace |
| Stablevalue | 0.50 dB | 0.50 dB |
| Run | -1 / max. 150 | max. 150 |
| Stable | -1 / 3 | 3 |
| Max Stable Difference | -1.00 dB | 0.50 dB |

5.2.4. Transmitter Radiated Emissions

Test Summary:

| | | | |
|-----------------------------------|--|-------------------|-------------|
| Test Engineer: | Segun Adeniji | Test Date: | 20 May 2018 |
| Test Sample Serial Number: | MS122017017612; MS122017015112; MS122017017112 | | |
| Test Site Identification | SR 1/2 | | |

| | |
|--------------------------|----------------------------------|
| FCC Reference: | Parts 15.247(d) & 15.209 |
| Test Method Used: | ANSI C63.10 Sections 6.3 and 6.5 |
| Frequency Range | 30 MHz to 1000 MHz |

Environmental Conditions:

| | |
|-------------------------------|----|
| Temperature (°C): | 21 |
| Relative Humidity (%): | 41 |

Note(s):

1. The final measured value, for the given emission, in the table below incorporates the calibrated antenna factor and cable loss.
2. The preliminary scans showed similar emission levels below 1 GHz, for each channel of operation. Therefore final radiated emissions measurements were performed with the EUT set to the worst case i.e. bottom channel only.
3. Measurements below 1 GHz were performed in a semi-anechoic chamber at a distance of 3 metres. The EUT was placed at a height of 80 cm above the reference ground plane in the centre of the chamber turntable. Maximum emission levels were determined by height searching the measurement antenna over the range 1 metre to 4 metres.
4. Pre-scans were performed and markers placed on the highest measured levels. The test receiver resolution bandwidth was set to 100 kHz and video bandwidth 300 kHz. A peak detector was used, sweep time was set to auto and trace mode was Max Hold.
5. Final measurements were performed on the marker frequencies and the results entered into the table below. The test receiver resolution bandwidth was set to 120 kHz, using a CISPR quasi-peak detector and span big enough to see the whole emission.

Test Setup:

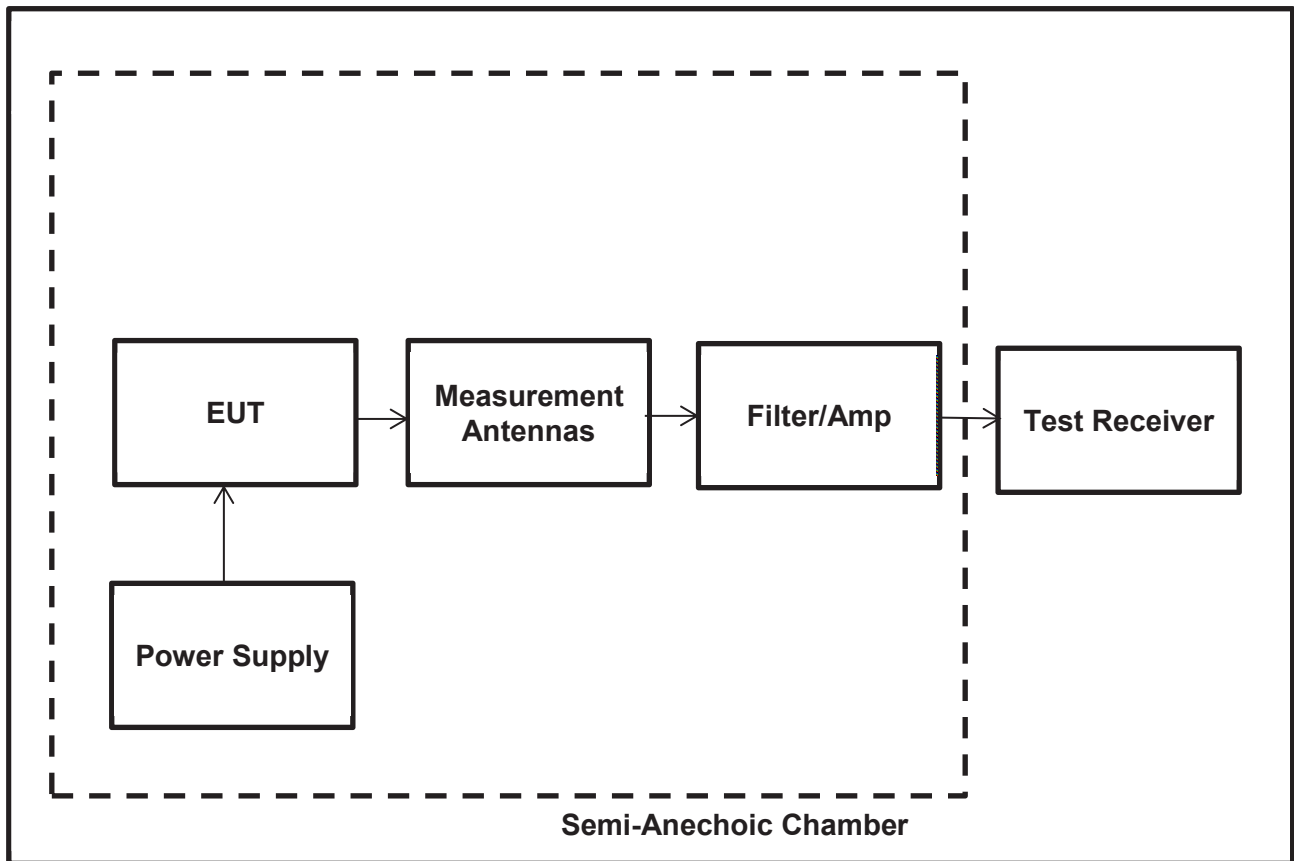

Results: Bottom Channel

| Frequency (MHz) | Antenna Polarization | MaxPeak Level (dBμV/m) | Limit (dBμV/m) | Margin (dB) | Result |
|-----------------|----------------------|------------------------|----------------|-------------|----------|
| 39.76 | V | 14.25 | 40.00 | 25.75 | Complied |
| 51.64 | V | 15.33 | 40.00 | 24.68 | Complied |
| 69.19 | V | 14.86 | 40.00 | 25.14 | Complied |
| 453.73 | H | 21.65 | 46.00 | 24.35 | Complied |
| 679.95 | V | 26.62 | 46.00 | 19.38 | Complied |
| 897.91 | H | 30.95 | 46.00 | 15.05 | Complied |

Plot: 30 MHz – 1GHz

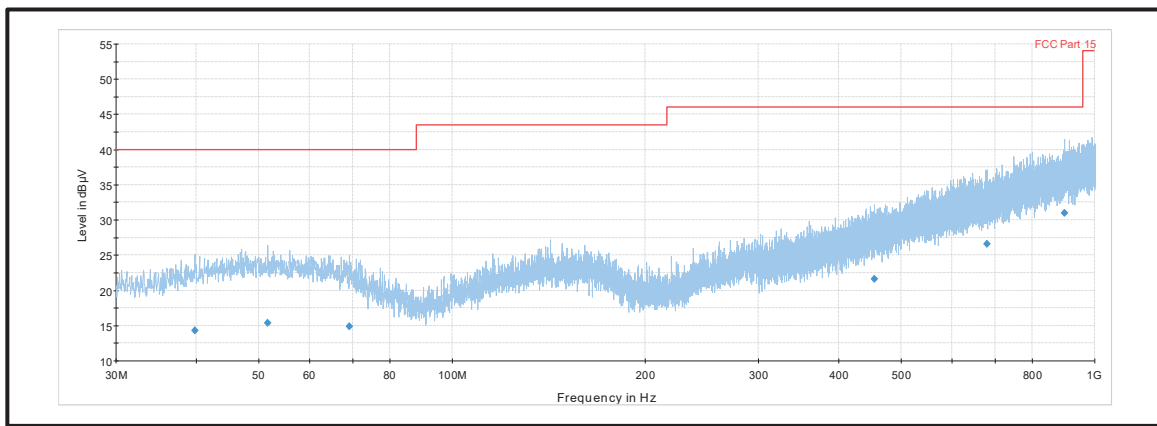

Note: This plot is a pre-scan and for indication purposes only. For final measurements, see accompanying table.

Result: Pass

Transmitter Radiated Emissions (continued)

Test Summary:

| | | | |
|-----------------------------------|--|-------------------|-------------|
| Test Engineer: | Segun Adeniji | Test Date: | 18 May 2018 |
| Test Sample Serial Number: | MS122017017612; MS122017015112; MS122017017112 | | |
| Test Site Identification | SR 1/2 | | |

| | |
|--------------------------|--|
| FCC Reference: | Parts 15.247(d) & 15.209(a) |
| Test Method Used: | FCC KDB 558074 Sections 11 & 12 referencing ANSI C63.10 Sections 6.3 and 6.6 |
| Frequency Range | 1 GHz to 25 GHz |

Environmental Conditions:

| | |
|-------------------------------|----|
| Temperature (°C): | 21 |
| Relative Humidity (%): | 41 |

Note(s):

1. The final measured value, for the given emission, in the table below incorporates the calibrated antenna factor and cable loss.
2. All the spurious emissions detected were re-investigated and re-measured with an average detector and in this case the emission was compared to the peak limit. For frequency range between 18 GHz and 25 GHz, no critical emission was found so only the measurement receiver noise floor level has been measured and recorded in the table The peak level was compared to the average limit as opposed to being compared to the peak limit because this is the more onerous limit. Only the middle channel plot was included in the report as similar result was obtained on both bottom and top channels.
3. The emission shown around the 2.4 GHz is the EUT fundamental.
4. Measurements above 1 GHz were performed in a semi-anechoic chamber at a distance of 3 metres. The EUT was placed at a height of 1.5 m above the reference ground plane in the centre of the chamber turntable. Maximum emission levels were determined by height searching the measurement antenna over the range 1 metre to 4 metres.
5. Pre-scans were performed and a marker placed on the highest measured level of the appropriate plot. The test receiver resolution bandwidth was set to 1 MHz and video bandwidth 3 MHz. The sweep time was set to auto.
6. *In accordance with ANSI C63.10 Section 6.6.4.3, Note 1, if the peak measured value complies with the average limit, it is unnecessary to perform an average measurement.
7. The reference level for the emission in the non-restricted band was established by following KDB 558074 Section 11.2 procedure.

Results:

Results: Peak / Bottom Channel

| Frequency (MHz) | Antenna Polarization | Level (dB μ V/m) | Limit (dB μ V/m) | Margin (dB) | Result |
|-----------------|----------------------|----------------------|----------------------|-------------|----------|
| 4803 | Horizontal | 58.66 | 74.0 | 15.34 | Complied |

Results: Average / Bottom Channel

| Frequency (MHz) | Antenna Polarization | Level (dB μ V/m) | Limit (dB μ V/m) | Margin (dB) | Result |
|-----------------|----------------------|----------------------|----------------------|-------------|----------|
| 4803 | Horizontal | 51.43 | 54.0 | 2.57 | Complied |

Results: Peak / Middle Channel

| Frequency (MHz) | Antenna Polarization | Level (dB μ V/m) | Limit (dB μ V/m) | Margin (dB) | Result |
|-----------------|----------------------|----------------------|----------------------|-------------|----------|
| 4852 | Horizontal | 53.13 | 74.0 | 20.87 | Complied |

Results: Average / Middle Channel

| Frequency (MHz) | Antenna Polarization | Level (dB μ V/m) | Limit (dB μ V/m) | Margin (dB) | Result |
|-----------------|----------------------|----------------------|----------------------|-------------|----------|
| 4852 | Horizontal | 49.21 | 54.0 | 4.79 | Complied |

Results: Peak / Top Channel

| Frequency (MHz) | Antenna Polarization | Level (dB μ V/m) | Limit (dB μ V/m) | Margin (dB) | Result |
|-----------------|----------------------|----------------------|----------------------|-------------|----------|
| 4959.67 | Vertical | 64.80 | 74.0 | 9.20 | Complied |

Results: Average / Top Channel

| Frequency (MHz) | Antenna Polarization | Level (dB μ V/m) | Limit (dB μ V/m) | Margin (dB) | Result |
|-----------------|----------------------|----------------------|----------------------|-------------|----------|
| 2479.92 | Vertical | 53.57 | 54.0 | 0.43 | Complied |

Result: **Pass**

Plot: 1 GHz – 18GHz (Bottom channel) with Peak detector

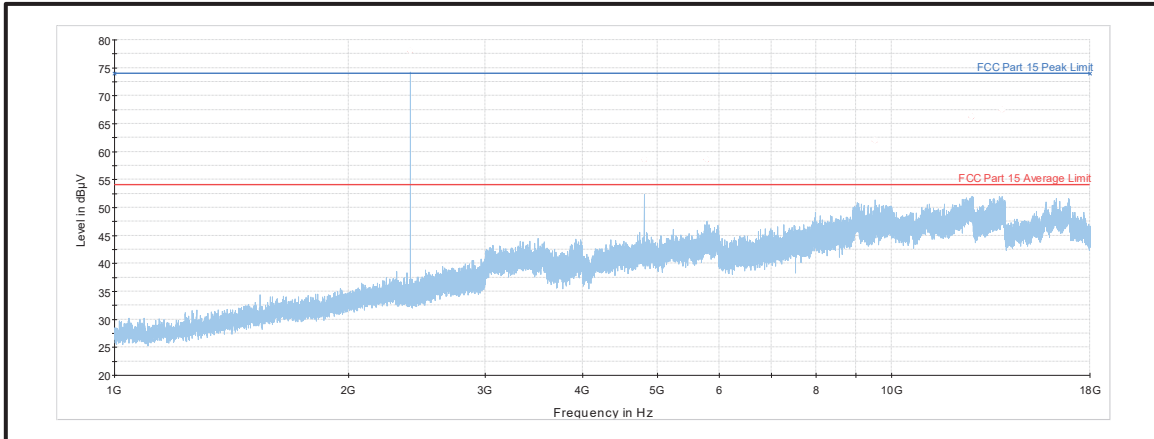

Plot: 1 GHz – 18GHz (Middle channel) with Peak detector

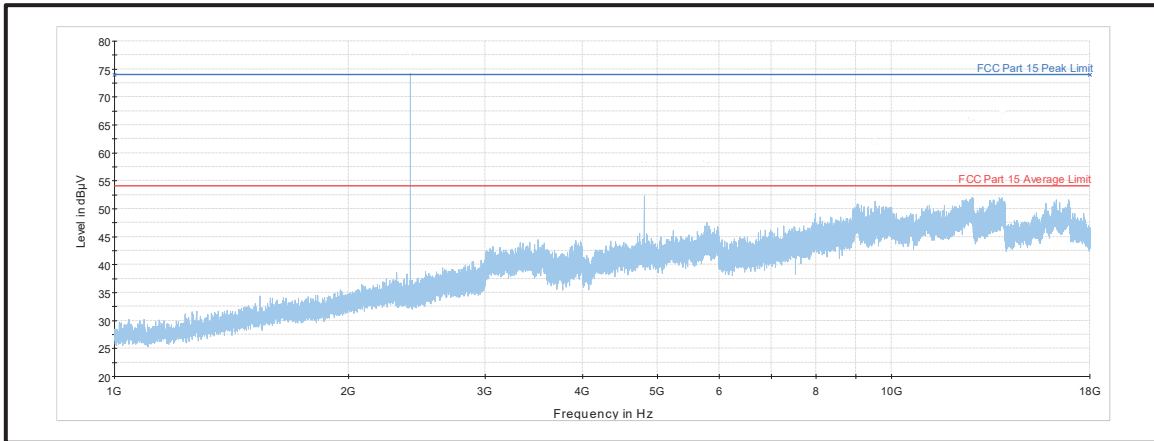

Plot: 1 GHz – 18GHz (Top channel) with Peak detector

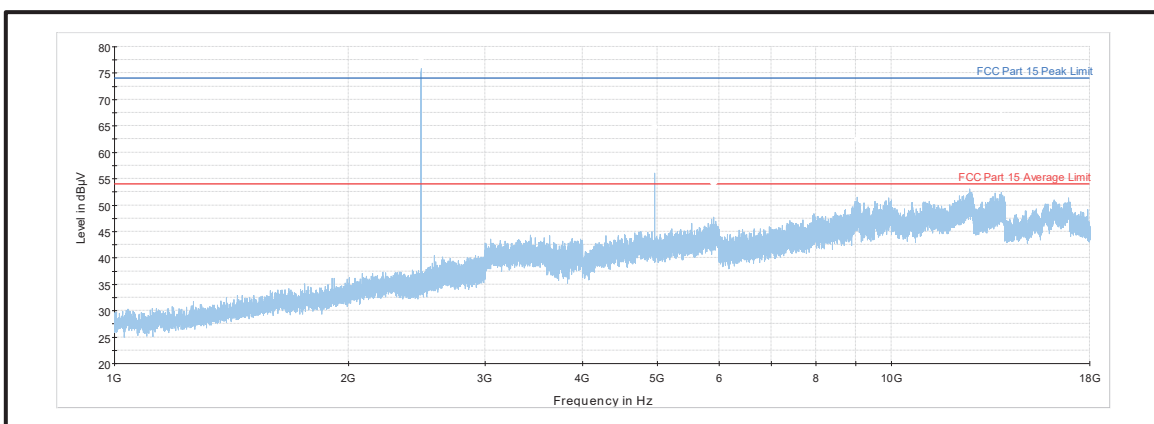

Plot: 18 GHz – 25GHz (Middle channel) with Peak detector

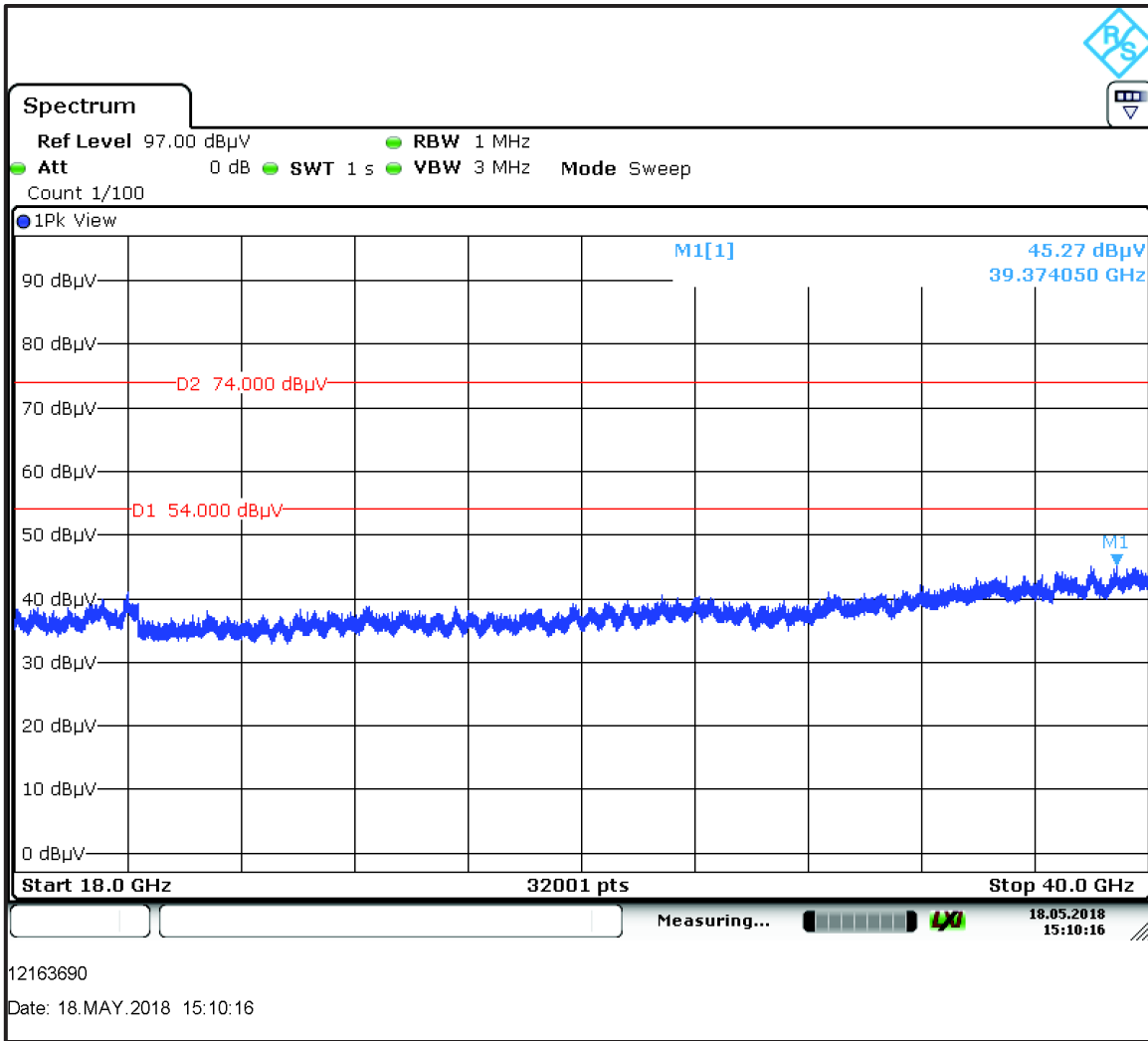

Note: The above plots are pre-scans with peak detector and for indication purposes only. For final measurements, see accompanying tables.

5.2.5. Transmitter Band Edge Radiated Emissions

Test Summary:

| | | | |
|-----------------------------------|--|-------------------|-------------|
| Test Engineer: | Segun I. Adeniji | Test Date: | 17 May 2018 |
| Test Sample Serial Number: | MS122017017612; MS122017015112; MS122017017112 | | |
| Test Site Identification | SR 1/2 | | |

| | |
|--------------------------|--|
| FCC Reference: | Parts 15.247(d) & 15.209(a) & 15.209(b) |
| Test Method Used: | ANSI C63.10 Section 6.10.4, 6.10.5 & KDB 558074 Section 11 |

Environmental Conditions:

| | |
|-------------------------------|----|
| Temperature (°C): | 21 |
| Relative Humidity (%): | 41 |

Note(s):

- As the lower band edges fall within non-restricted bands, only peak measurements are required. In accordance with FCC KDB 558074 Section 11.1, the test method in Section 11.3 was followed: the test receiver resolution bandwidth was set to 100 kHz and video bandwidth 300 kHz. A peak detector was used, sweep time was set to auto and trace mode was Max Hold. The test receiver was left to sweep for a sufficient length of time in order to maximise the carrier level and out-of-band emissions. A marker and corresponding reference level line were placed on the peak of the carrier. As the maximum peak conducted output power was measured using a peak detector in accordance with FCC KDB 558074 Section 9.1.1 an out-of-band limit line was placed 20 dB below the peak level (FCC KDB 558074 Section 11.1(a)). A marker was placed on the band edge spot frequencies and a second marker placed on the highest emission level in the adjacent non-restricted band of operation (where a higher level emission was present). Marker frequencies and levels were recorded.
- As the upper band edge falls within a restricted band both peak and average measurements were recorded by placing a marker at the edge of the band. For peak measurements the test receiver resolution bandwidth was set to 1 MHz and the video bandwidth 3 MHz. A peak detector was used, sweep time was set to auto and trace mode was Max Hold. For average measurements the test receiver resolution bandwidth was set to 1 MHz and the video bandwidth 3 MHz. An average detector was used, sweep time was set to auto and trace mode was Max Hold. The test receiver was left to sweep for a sufficient length of time in order to maximise the carrier level and out-of-band emissions. A marker was placed on the band edge spot frequencies and a second marker placed on the highest emission level in the adjacent restricted band of operation (where a higher level emission was present). Marker frequencies and levels were recorded.
- There is a restricted band 10 MHz below the lower band edge. The test receiver was set up as follows: the RBW set to 1 MHz, the VBW set to 3 MHz, with the sweep time set to auto couple. Peak and average measurements were performed with their respective detectors. Markers were placed on the highest point on each trace.
- *Emissions in restricted bands: In accordance with C63.10 Section 6.6.4.3, Note 1, where the peak detected amplitude was shown to comply with the average limit, an average measurement was not performed.

Test Setup:

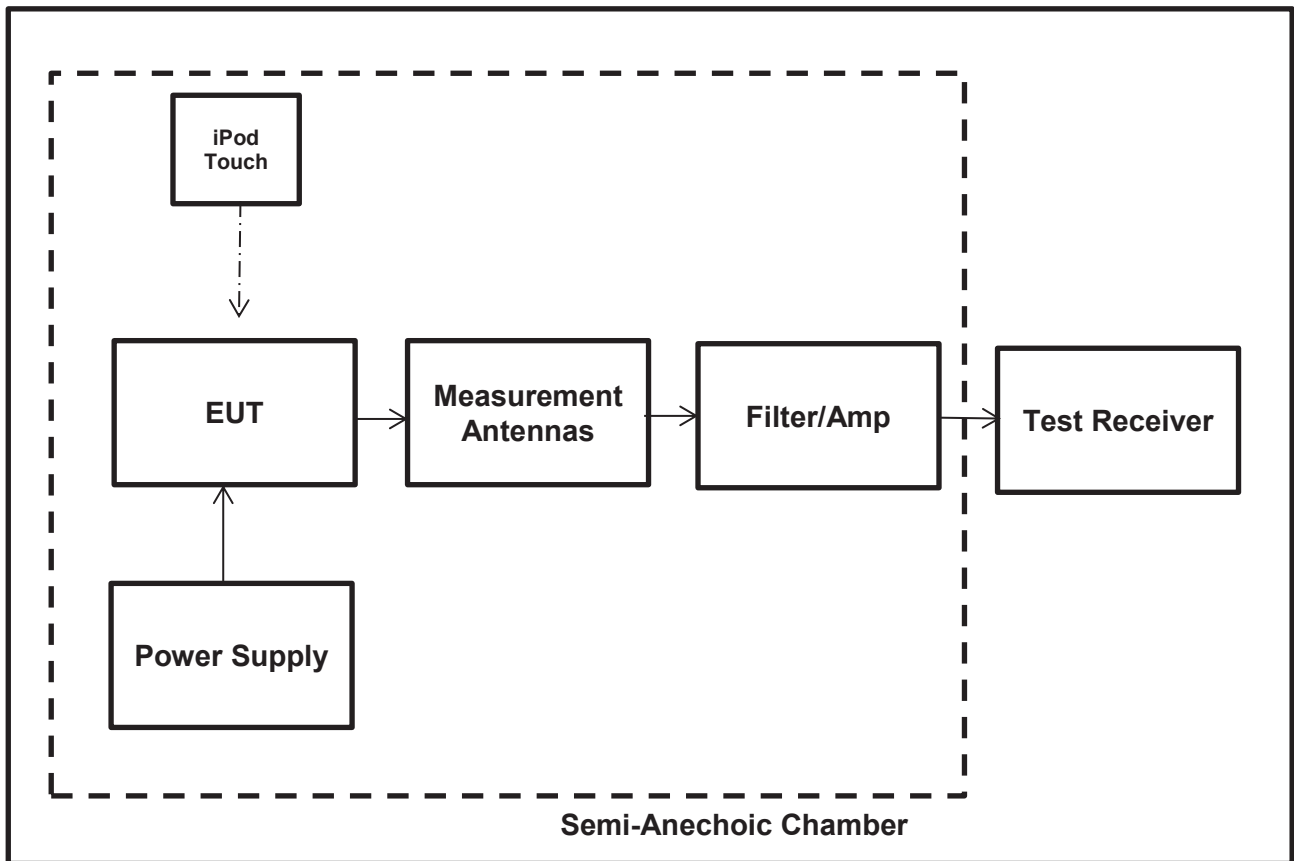

Results: Lower Band Edge/Peak

| Frequency (MHz) | Level (dB μ V/m) | -20 dBc Limit (dB μ V/m) | Margin (dB) | Result |
|-----------------|----------------------|------------------------------|-------------|----------|
| 2400.000 | 75.47 | 97.51 | 22.04 | Complied |
| 2386.661 | 75.20 | 97.51 | 22.31 | Complied |

Results: Upper Band Edge / Restricted Band / Peak

| Frequency (MHz) | Level (dB μ V/m) | Limit (dB μ V/m) | Margin (dB) | Result |
|-----------------|----------------------|----------------------|-------------|----------|
| 2483.500 | 54.63 | 74.0 | 19.37 | Complied |

Results: Upper Band Edge / Restricted Band / Average

| Frequency (MHz) | Average Level (dB μ V/m) | Limit (dB μ V/m) | Margin (dB) | Result |
|-----------------|------------------------------|----------------------|-------------|----------|
| 2483.500 | 47.45 | 54.0 | 6.55 | Complied |

Results: 2310 to 2390 MHz Restricted Band / Peak

| Frequency (MHz) | Peak Level (dB μ V/m) | Limit (dB μ V/m) | Margin (dB) | Result |
|-----------------|---------------------------|----------------------|-------------|----------|
| 2364.62 | 57.02 | 74.0 | 16.98 | Complied |

Results: 2310 to 2390 MHz Restricted Band / Average

| Frequency (MHz) | Average Level (dB μ V/m) | Limit (dB μ V/m) | Margin (dB) | Result |
|-----------------|------------------------------|----------------------|-------------|----------|
| 2334.45 | 47.77 | 54.0 | 6.23 | Complied |

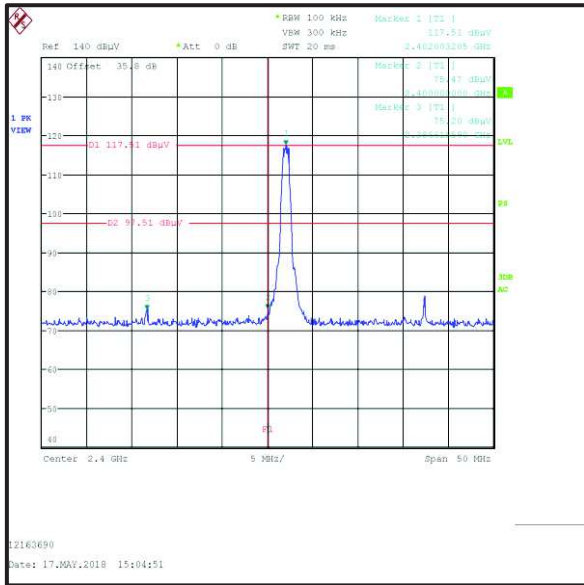

Lower Band Edge Peak Measurement

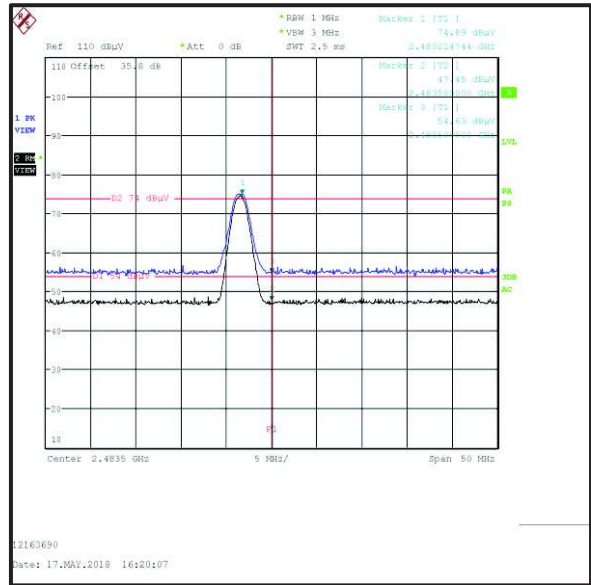

Upper Band Edge Peak Measurement

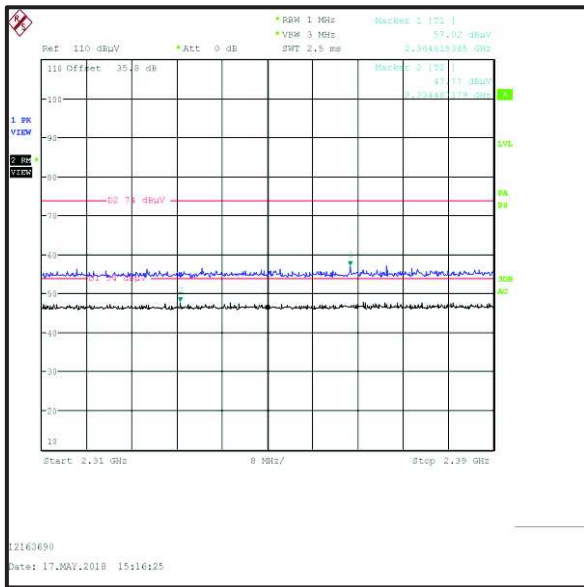

2310 MHz to 2390 MHz Restricted Band Plot

6. Measurement Uncertainty

The expression of uncertainty of a measurement result allows realistic comparison of results with reference values and limits given in specifications and standards.

The uncertainty of the result may need to be taken into account when interpreting the measurement results.

The reported expanded uncertainties below are based on a standard uncertainty multiplied by an appropriate coverage factor such that a confidence level of approximately 95% is maintained. For the purposes of this document “approximately” is interpreted as meaning “effectively” or “for most practical purposes”.

| Measurement Type | Confidence Level (%) | Calculated Uncertainty |
|-------------------------------------|----------------------|------------------------|
| AC Conducted Spurious Emissions | 95% | ±2.49 dB |
| Conducted Maximum Peak Output Power | 95% | ±0.59 dB |
| Radiated Spurious Emissions | 95% | ±3.10 dB |
| Band Edge Radiated Emissions | 95% | ±3.10 dB |
| Minimum 6 dB Bandwidth | 95% | ±0.87 % |

The methods used to calculate the above uncertainties are in line with those recommended within the various measurement specifications. Where measurement specifications do not include guidelines for the evaluation of measurement uncertainty the published guidance of the appropriate accreditation body is followed.

7. Used equipment

Test site: SR 1/2

| ID | Manufacturer | Type | Model | Serial No. | Calibration Date | Cal. Cycle |
|-----|------------------------|----------------------------|---------------|--------------|------------------|------------|
| 350 | Rohde & Schwarz | Receiver, EMI Test | ESIB7 | 836697/014 | 7/13/2017 | 12 |
| 377 | Bonn Elektronik | Amplifier, Low Noise Pre | BLMA 0118-1A | 025294B | 7/11/2017 | 12 |
| 423 | Bonn Elektronik | Amplifier, Low Noise Pre | BLMA 1840-1A | 055929 | 7/12/2017 | 12 |
| 460 | Deisl | Turntable | DT 4250 S | | n/a | n/a |
| 465 | Schwarzbeck | Antenna, Trilog Broadband | VULB 9168 | 9168-240 | 8/8/2016 | 36 |
| 496 | Rohde & Schwarz | Antenna, log. - periodical | HL050 | 100297 | 7/20/2016 | 24 |
| 587 | Maturo | antenna mast, tilting | TAM 4.0-E | 011/7180311 | n/a | n/a |
| 588 | Maturo | Controller | NCD | 029/7180311 | n/a | n/a |
| 591 | Rohde & Schwarz | Receiver | ESU 40 | 100244/040 | 7/12/2017 | 12 |
| 608 | Rohde & Schwarz | Switch Matrix | OSP 120 | 101227 | 4/8/2014 | 60 |
| 614 | Wainwright Instruments | Highpass Filter 3GHz | WHKX10- | 1 | Lab verification | n/a |
| 615 | Wainwright Instruments | Highpass Filter 1GHz | WHKX12- | 3 | Lab verification | n/a |
| 620 | Bonn Elektronik | pre-amplifier | BLNA 0110-01N | 1510111 | 7/12/2017 | 24 |
| 628 | Maturo | Antenna mast | CAM 4.0-P | 224/19590716 | n/a | n/a |
| 629 | Maturo | Kipheinrichtung | KE 2.5-R-M | MAT002 | n/a | n/a |

Test site: SR 9

| ID | Manufacturer | Type | Model | Serial No. | Calibration Date | Cal. Cycle |
|-----|-----------------|------------------------------|------------|------------|------------------------|------------|
| 634 | Rohde & Schwarz | Wireless Devices Test System | TS8997 | | 7/11/2017 | 12 |
| 636 | Rohde & Schwarz | switching unit | OSP120 | 101698 | 7/14/2017 | 12 |
| 637 | Rohde & Schwarz | Spectrum Analyzer | FSV40 | 101587 | 7/11/2017 | 12 |
| 195 | SPS | Power Supply | TOE8842-24 | 51455 | Verified by Multimeter | 12 |
| 216 | Agilent | Multimeter | 34401A | US36017458 | 7/11/2017 | 24 |

Test site: SR 7/8

| ID | Manufacturer | Type | Model | Serial No. | Calibration Date | Cal. Cycle |
|-----|-----------------|--------------------------|-------------------------|------------|------------------|------------|
| 22 | Rohde & Schwarz | Artificial Mains | 50 Ohm// 50uH | 831767/014 | 7/12/2017 | 12 |
| 215 | Rohde & Schwarz | Artificial Mains Network | 9 kHz - 30 MHz; 3 phase | 879675/002 | 7/12/2017 | 12 |
| 350 | Rohde & Schwarz | Receiver, EMI Test | 20 Hz - 7 GHz | 836697/014 | 7/13/2017 | 12 |
| 616 | Rohde & Schwarz | ISN | 8 wire ISN for CAT6 | 101656 | 7/13/2017 | 12 |

8. Report Revision History

| Version Number | Revision Details | | |
|----------------|------------------|--------|-----------------|
| | Page No(s) | Clause | Details |
| 1.0 | - | - | Initial Version |