

# FCC RADIO TEST REPORT

## FCC 47 CFR PART 15 SUBPART C

<b>Test Standard</b>	<b>FCC Part 15.247</b>
<b>Brand name</b>	<b>raybaby</b>
<b>Product name</b>	<b>Baby Monitoring device</b>
<b>Model No.</b>	<b>RYBBY01</b>
<b>Test Result</b>	<b>Pass</b>

The test Result was tested by Compliance Certification Services Inc. The test data, data evaluation, test procedures, and equipment configurations shown in this report were given in ANSI C63.10: 2013 and compliance standards.

The test results of this report relate only to the tested sample (EUT) identified in this report.

The test Report of full or partial shall not copy. Without written approval of Compliance Certification Services Inc. ( Wugu Laboratory)

Approved by:

Tested by:



---

Sam Chuang  
Manager

---

Jerry Chuang  
Engineer

Unless otherwise stated the results shown in this test report refer only to the sample(s) tested and such sample(s) are retained for 90 days only.  
除非另有說明，此報告結果僅對測試之樣品負責，同時此樣品僅保留90天。本報告未經本公司書面許可，不可部分複製。

This document is issued by the Company subject to its General Conditions of Service printed overleaf, available on request or accessible at [www.sgs.com/terms\\_and\\_conditions.htm](http://www.sgs.com/terms_and_conditions.htm) and for electronic format documents, subject to Terms and Conditions for Electronic Documents at [www.sgs.com/terms\\_e-document.htm](http://www.sgs.com/terms_e-document.htm). Attention is drawn to the limitation of liability, indemnification and jurisdiction issues defined therein. Any holder of this document is advised that information contained hereon reflects the Company's findings at the time of its intervention only and within the limits of Client's instructions, if any. The Company's sole responsibility is to its Client and this document does not exonerate parties to a transaction from exercising all their rights and obligations under the transaction documents. This document cannot be reproduced except in full, without prior written approval of the Company. Any unauthorized alteration, forgery or falsification of the content or appearance of this document is unlawful and offenders may be prosecuted to the fullest extent of the law.



Report No.: T180420W02-RP

Page: 2 / 80  
Rev.: 01

## Revision History

Rev.	Issue Date	Revisions	Revised By
00	June 14, 2018	Initial Issue	Allison Chen
01	July 20, 2018	1. Revised section 1.2 in page 5. 2. Revised section 1.6 in page 7. 3. Remote test voltage in page 14-15.	Allison Chen



Report No.: T180420W02-RP

Page: 3 / 80  
Rev.: 01

## Table of contents

1.	GENERAL INFORMATION.....	4
1.1	EUT INFORMATION.....	4
1.2	EUT CHANNEL INFORMATION.....	5
1.3	ANTENNA INFORMATION.....	5
1.4	MEASUREMENT UNCERTAINTY .....	6
1.5	FACILITIES AND TEST LOCATION.....	6
1.6	INSTRUMENT CALIBRATION .....	7
1.7	SUPPORT AND EUT ACCESSORIES EQUIPMENT .....	8
1.8	TEST METHODOLOGY AND APPLIED STANDARDS.....	8
2.	TEST SUMMERY .....	9
3.	DESCRIPTION OF TEST MODES.....	10
3.1	THE WORST MODE OF OPERATING CONDITION .....	10
3.2	THE WORST MODE OF MEASUREMENT.....	11
3.3	EUT DUTY CYCLE .....	12
4.	TEST RESULT .....	13
4.1	AC POWER LINE CONDUCTED EMISSION.....	13
4.2	6DB BANDWIDTH AND OCCUPIED BANDWIDTH (99%).....	16
4.3	OUTPUT POWER MEASUREMENT .....	24
4.4	POWER SPECTRAL DENSITY .....	26
4.5	CONDUCTED BANDEDGE AND SPURIOUS EMISSION.....	31
4.6	RADIATION BANDEDGE AND SPURIOUS EMISSION.....	41
APPENDIX I PHOTOGRAPHS OF EUT		

Report No.: T180420W02-RP

## 1. GENERAL INFORMATION

### 1.1 EUT INFORMATION

<b>Applicant</b>	RIOT SOLUTIONS, INC 2711 Centerville Road, Suite 400, Wilmington, New Castle County, Delaware 19808, USA
<b>Manufacturer</b>	RIOT SOLUTIONS, INC 2711 Centerville Road, Suite 400, Wilmington, New Castle County, Delaware 19808, USA
<b>Equipment</b>	Baby Monitoring device
<b>Model No.</b>	RYBBY01
<b>Model Discrepancy</b>	N/A
<b>Received Date</b>	April 20, 2018
<b>Date of Test</b>	June 6 ~ 14, 2018
<b>Output Power(W)</b>	IEEE 802.11b mode: 0.05834 IEEE 802.11g mode: 0.19143 IEEE 802.11n HT 20 MHz mode: 0.17579
<b>Power Supply</b>	Powered from Adapter. I/P: 100-240Vac, 0.3A, 50-60Hz O/P: 5Vdc, 2.1A

Report No.: T180420W02-RP

## 1.2 EUT CHANNEL INFORMATION

Frequency Range	2412MHz-2462MHz
Modulation Type	1. IEEE 802.11b mode: CCK 2. IEEE 802.11g mode: OFDM 3. IEEE 802.11n HT 20 MHz mode: OFDM
Channel Numbers	1. IEEE 802.11b mode: 11 Channels 2. IEEE 802.11g mode: 11 Channels 3. IEEE 802.11n HT 20 MHz mode: 11 Channels

**Remark:**

Refer as ANSI 63.10:2013 clause 5.6.1 Table 4 for test channels

Number of frequencies to be tested		
Frequency range in which device operates	Number of frequencies	Location in frequency range of operation
<input type="checkbox"/> 1 MHz or less	1	Middle
<input type="checkbox"/> 1 MHz to 10 MHz	2	1 near top and 1 near bottom
<input checked="" type="checkbox"/> More than 10 MHz	3	1 near top, 1 near middle, and 1 near bottom

## 1.3 ANTENNA INFORMATION

Antenna Type	<input type="checkbox"/> PIFA <input checked="" type="checkbox"/> PCB <input type="checkbox"/> Dipole <input type="checkbox"/> Coils
Antenna Gain	Internal Antenna (FPC 2.4G antenna) / Gain: 1dBi

Report No.: T180420W02-RP

## 1.4 MEASUREMENT UNCERTAINTY

PARAMETER	UNCERTAINTY
AC Powerline Conducted Emission	+/- 2.96
Emission bandwidth, 20dB bandwidth	+/- 1.4003
RF output power, conducted	+/- 1.1372
Power density, conducted	+/- 1.4003
3M Semi Anechoic Chamber / 30M~200M	+/- 4.0138
3M Semi Anechoic Chamber / 200M~1000M	+/- 3.9483
3M Semi Anechoic Chamber / 1G~8G	+/- 2.5975
3M Semi Anechoic Chamber / 8G~18G	+/- 2.6112
3M Semi Anechoic Chamber / 18G~26G	+/- 2.7389
3M Semi Anechoic Chamber / 26G~40G	+/- 2.9683
3M Semi Anechoic Chamber / 40G~60G	+/- 1.8509
3M Semi Anechoic Chamber / 60G~75G	+/- 1.9869
3M Semi Anechoic Chamber / 75G~110G	+/- 2.9651
3M Semi Anechoic Chamber / 110G~170G	+/- 2.7807
3M Semi Anechoic Chamber / 170G~220G	+/- 3.6437
3M Semi Anechoic Chamber / 220G~325G	+/- 4.2982

**Remark:**

1. This uncertainty represents an expanded uncertainty expressed at approximately the 95% confidence level using a coverage factor of  $k=2$
2. ISO/IEC 17025 requires that an estimate of the measurement uncertainties associated with the emissions test results be included in the report.

## 1.5 FACILITIES AND TEST LOCATION

All measurement facilities used to collect the measurement data are located at

No.11, Wugong 6th Rd., Wugu Dist., New Taipei City 24891, Taiwan. (R.O.C.)

Test site	Test Engineer	Remark
AC Conduction Room	Dally Hong	-
Radiation	Jerry Chuang	-
RF Conducted	Dally Hong	-

**Remark:** The sites are constructed in conformance with the requirements of ANSI C63.7, ANSI C63.4 and CISPR Publication 22.

Report No.: T180420W02-RP

## 1.6 INSTRUMENT CALIBRATION

RF Conducted Test Site					
Equipment	Manufacturer	Model	Serial Number	Calibration Date	Calibration Due
Power Meter	Anritsu	ML2495A	1012009	09/18/2017	09/17/2018
Power Sensor	Anritsu	MA2411B	917072	09/18/2017	09/17/2018
Spectrum Analyzer	R&S	FSV 40	101073	10/02/2017	10/01/2018
Thermostatic/Hrgrosatic Chamber	TAICHY	MHG-150LF	930619	10/11/2017	10/10/2018
Directional Coupler	Agilent	87301D	MY44350252	07/25/2017	07/24/2018
SUCOFLEX Cable	HUBER SUHNER	SUCOFLEX 104PEA	25157	07/31/2017	07/30/2018
Divider	Solvang Technology	2-18GHz 4Way	STI08-0015	07/26/2017	07/25/2018

3M 966 Chamber Test Site					
Equipment	Manufacturer	Model	Serial Number	Calibration Date	Calibration Due
Bilog Antenna	Sunol Sciences	JB3	A030105	06/20/2017	06/19/2018
Horn Antenna	ETC	MCTD 1209	DRH13M02003	08/25/2017	08/24/2018
Pre-Amplifier	EMEC	EM330	60609	06/06/2018	06/05/2019
Spectrum Analyzer	Agilent	E4446A	US42510252	11/27/2017	11/26/2018
Loop Ant	COM-POWER	AL-130	121051	03/21/2018	03/20/2019
Antenna Tower	CCS	CC-A-1F	N/A	N.C.R	N.C.R
Controller	CCS	CC-C-1F	N/A	N.C.R	N.C.R
Turn Table	CCS	CC-T-1F	N/A	N.C.R	N.C.R
Pre-Amplifier	HP	8449B	3008A00965	06/27/2017	06/26/2018
Filter	Micro Tronics	BRM 50702	120	05/14/2018	05/13/2019
Cable	HUBER SUHNER	SUCOFLEX 104PEA	25157	07/31/2017	07/30/2018
Cable	HUBER SUHNER	SUCOFLEX 104PEA	20995	07/31/2017	07/30/2018

AC Conducted Emissions Test Site					
Equipment	Manufacturer	Model	Serial Number	Calibration Date	Calibration Due
LISN	R&S	ENV216	101054	02/06/2018	02/05/2019
LISN	SCHWARZBECK	NSLK 8127	8127-541	02/09/2018	02/08/2019
EMI Test Receiver	R&S	ESCI	101203	11/02/2017	11/01/2018
CABLE	EMCI	CFD300-NL	CERF	07/03/2017	07/02/2018

**Note:**

1. The calibration interval of the above test instruments is 12 months and the calibrations are traceable to NML/ROC and NIST/USA.
2. N.C.R. = No Calibration Required.



Report No.: T180420W02-RP

Page: 8 / 80  
Rev.: 01

## 1.7 SUPPORT AND EUT ACCESSORIES EQUIPMENT

EUT Accessories Equipment					
No.	Equipment	Brand	Model	Series No.	FCC ID
	N/A				

Support Equipment					
No.	Equipment	Brand	Model	Series No.	FCC ID
	N/A				

## 1.8 TEST METHODOLOGY AND APPLIED STANDARDS

The test methodology, setups and results comply with all requirements in accordance with ANSI C63.10:2013, FCC Part 2, FCC Part 15.247, KDB 558074 D01 v04, KDB 662911.





Report No.: T180420W02-RP

## 2. TEST SUMMERY

FCC Standard Section	Report Section	Test Item	Result
15.203	1.3	Antenna Requirement	Pass
15.207(a)	4.1	AC Conducted Emission	Pass
15.247(a)(2)	4.2	6 dB Bandwidth	Pass
15.247(b)	4.3	Output Power Measurement	Pass
15.247(e)	4.4	Power Spectral Density	Pass
15.247(d)	4.5	Conducted Band Edge	Pass
15.247(d)	4.5	Conducted Emission	Pass
15.247(d)	4.6	Radiation Band Edge	Pass
15.247(d)	4.6	Radiation Spurious Emission	Pass

Report No.: T180420W02-RP

### 3. DESCRIPTION OF TEST MODES

#### 3.1 THE WORST MODE OF OPERATING CONDITION

Operation mode	IEEE 802.11b mode :1Mbps IEEE 802.11g mode :6Mbps IEEE 802.11n HT20 mode :MCS0
Test Channel Frequencies	<b>IEEE 802.11b mode :</b> 1. Lowest Channel : 2412MHz 2. Middle Channel : 2437MHz 3. Highest Channel : 2462MHz <b>IEEE 802.11g mode :</b> 1. Lowest Channel : 2412MHz 2. Middle Channel : 2437MHz 3. Highest Channel : 2462MHz <b>IEEE 802.11n HT20 mode :</b> 1. Lowest Channel : 2412MHz 2. Middle Channel : 2437MHz 3. Highest Channel : 2462MHz
Operation Transmitter	IEEE 802.11b mode :1T1R IEEE 802.11g mode :1T1R IEEE 802.11n HT20 mode :1T1R

**Remark:** EUT pre-scanned data rate of output power for each mode, the worst data rate were recorded in this report.

Report No.: T180420W02-RP

### 3.2 THE WORST MODE OF MEASUREMENT

AC Power Line Conducted Emission	
Test Condition	AC Power line conducted emission for line and neutral
Voltage/Hz	120V/60Hz
Test Mode	Mode 1:EUT power by adapter.
Worst Mode	<input checked="" type="checkbox"/> Mode 1 <input type="checkbox"/> Mode 2 <input type="checkbox"/> Mode 3 <input type="checkbox"/> Mode 4

Radiated Emission Measurement Above 1G	
Test Condition	Band edge, Emission for Unwanted and Fundamental
Voltage/Hz	120V/60Hz
Test Mode	Mode 1:EUT power by adapter.
Worst Mode	<input checked="" type="checkbox"/> Mode 1 <input type="checkbox"/> Mode 2 <input type="checkbox"/> Mode 3 <input type="checkbox"/> Mode 4
Worst Position	<input type="checkbox"/> Placed in fixed position. <input checked="" type="checkbox"/> Placed in fixed position at X-Plane (E2-Plane) <input type="checkbox"/> Placed in fixed position at Y-Plane (E1-Plane) <input type="checkbox"/> Placed in fixed position at Z-Plane (H-Plane)
Worst Polarity	<input checked="" type="checkbox"/> Horizontal <input type="checkbox"/> Vertical

Radiated Emission Measurement Below 1G	
Test Condition	Radiated Emission Below 1G
Voltage/Hz	120V/60Hz
Test Mode	Mode 1:EUT power by adapter.
Worst Mode	<input checked="" type="checkbox"/> Mode 1 <input type="checkbox"/> Mode 2 <input type="checkbox"/> Mode 3 <input type="checkbox"/> Mode 4

**Remark:**

1. The worst mode was record in this test report.
2. EUT pre-scanned in three axis ,X, Y, Z and two polarity, Horizontal and Vertical for radiated measurement. The worst case(X-Plane and Horizontal) were recorded in this report
3. For below 1G, AC power line conducted emission and radiation emission were performed the EUT transmit at the highest output power channel as worse case.

Report No.: T180420W02-RP

### 3.3 EUT DUTY CYCLE

Duty Cycle				
Configuration	TX ON (ms)	TX ALL (ms)	Duty Cycle (%)	Duty Factor(dB)
802.11b	4.5297	4.5430	99.71%	0.01
802.11g	0.7605	0.7852	96.86%	0.14
802.11n HT 20	0.6538	0.6738	97.03%	0.13

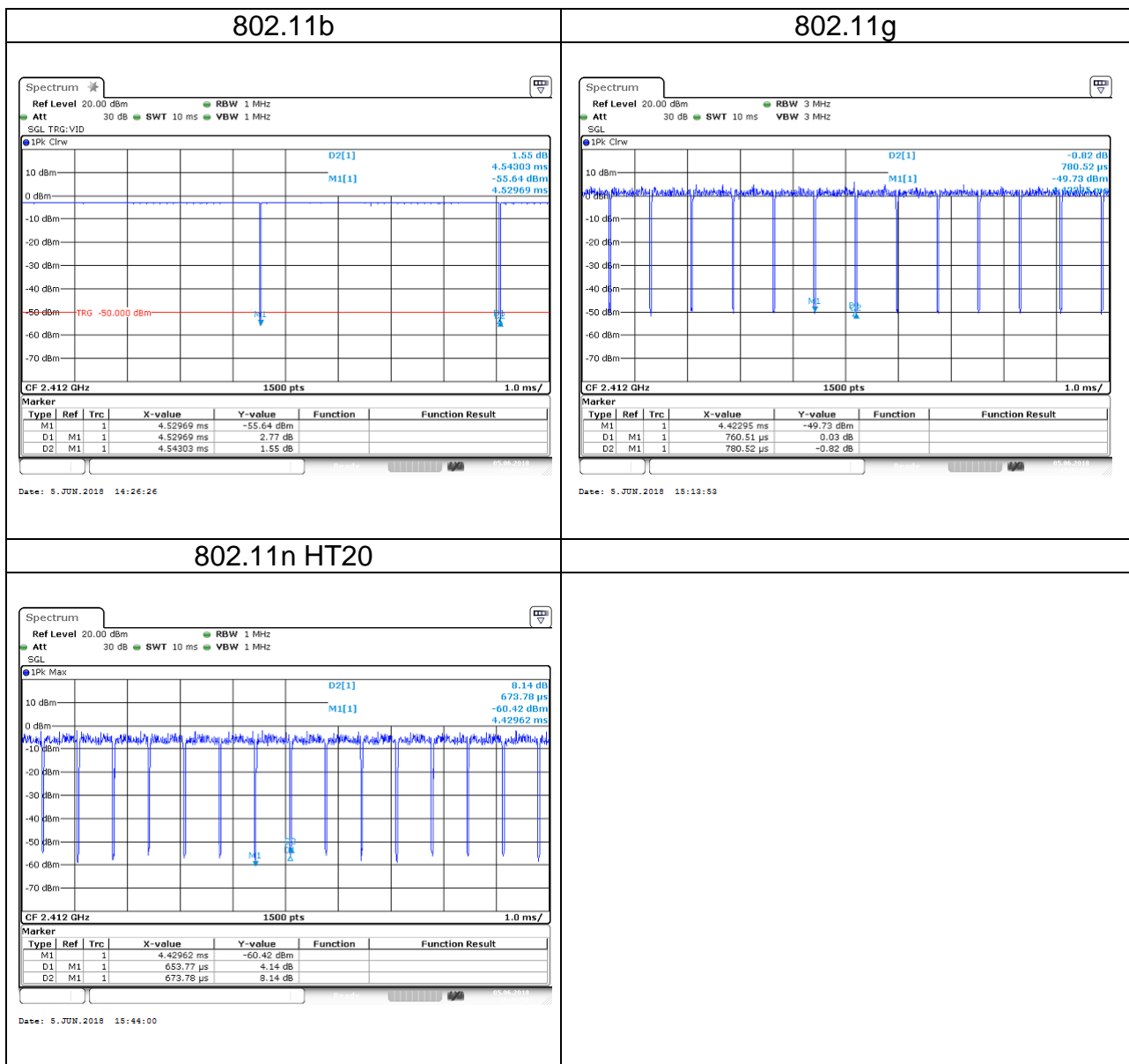

Report No.: T180420W02-RP

## 4. TEST RESULT

### 4.1 AC POWER LINE CONDUCTED EMISSION

#### 4.1.1 Test Limit

According to §15.207(a)(2)

Frequency Range (MHz)	Limits(dBµV)	
	Quasi-peak	Average
0.15 to 0.50	66 to 56*	56 to 46*
0.50 to 5	56	46
5 to 30	60	50

\* Decreases with the logarithm of the frequency.

#### 4.1.2 Test Procedure

Test method Refer as ANSI 63.10:2013 clause 6.2,

1. The EUT was placed on a non-conducted table, which is 0.8m above horizontal ground plane and 0.4m above vertical ground plane.
2. EUT connected to the line impedance stabilization network (LISN)
3. Receiver set RBW of 9kHz and Detector Peak, and note as quasi-peak and average.
4. Maximum procedure was performed on the six highest emissions to ensure EUT compliance.
5. Recorded Line for Neutral and Line.

#### 4.1.3 Test Setup

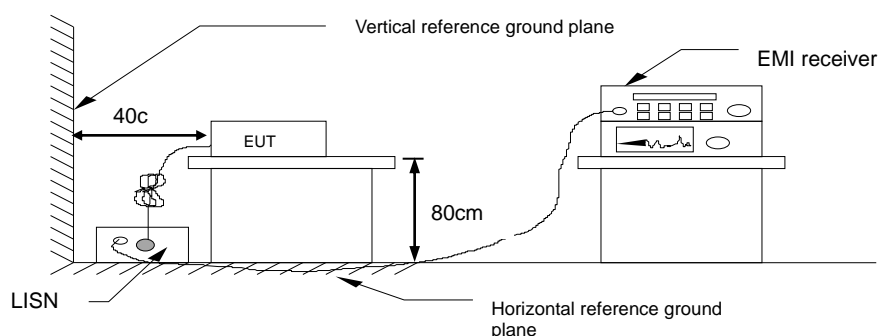

#### 4.1.4 Test Result

**Pass.**

Report No.: T180420W02-RP

### Test Data

Test Mode:	Mode 1	Temp/Hum	24(°C) / 50%RH
Phase:	Line	Test Date	2018/06/14
		Test Engineer	Dally Hong

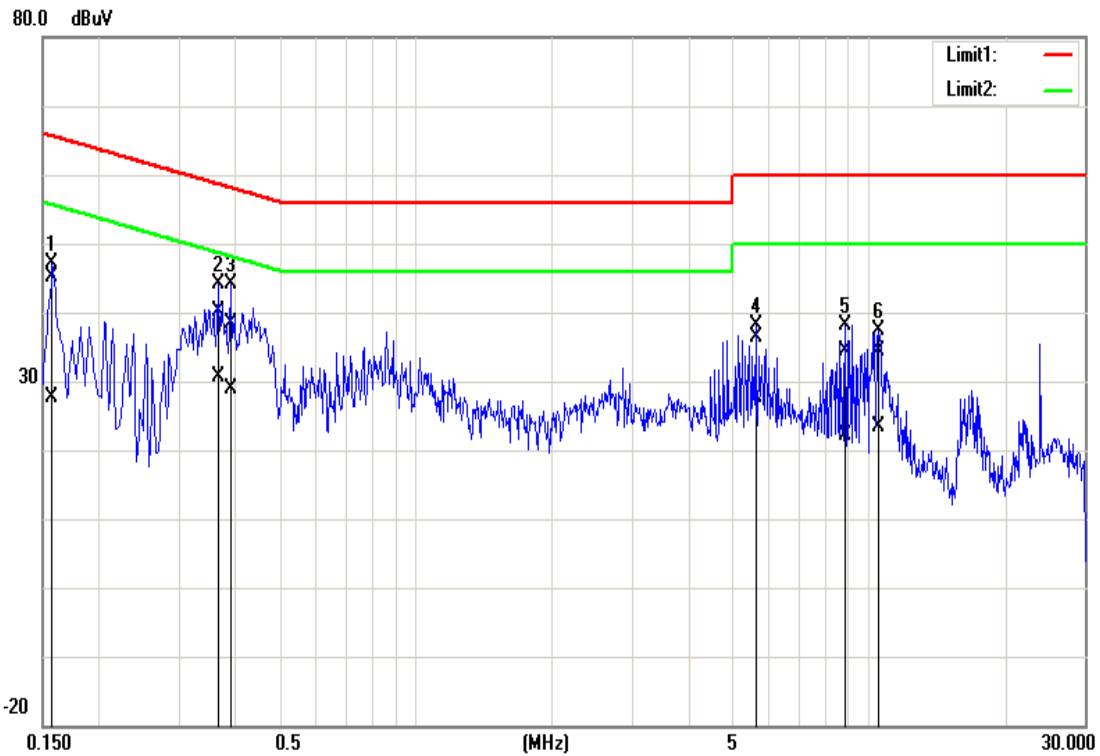

No.	Frequency (MHz)	QuasiPeak reading (dBuV)	Average reading (dBuV)	Correction factor (dB)	QuasiPeak result (dBuV)	Average result (dBuV)	QuasiPeak limit (dBuV)	Average limit (dBuV)	QuasiPeak margin (dB)	Average margin (dB)	Remark
1	0.1582	45.02	27.62	0.11	45.13	27.73	65.56	55.56	-20.43	-27.83	Pass
2*	0.3660	40.06	30.54	0.12	40.18	30.66	58.59	48.59	-18.41	-17.93	Pass
3	0.3900	38.37	28.68	0.12	38.49	28.80	58.06	48.06	-19.57	-19.26	Pass
4	5.6380	36.17	27.31	0.22	36.39	27.53	60.00	50.00	-23.61	-22.47	Pass
5	8.8860	34.18	21.91	0.28	34.46	22.19	60.00	50.00	-25.54	-27.81	Pass
6	10.5260	33.96	23.18	0.31	34.27	23.49	60.00	50.00	-25.73	-26.51	Pass

Report No.: T180420W02-RP

Test Mode:	Mode 1	Temp/Hum	24(°C) / 50%RH
Phase:	Neutral	Test Date	2018/06/14
		Test Engineer	Dally Hong

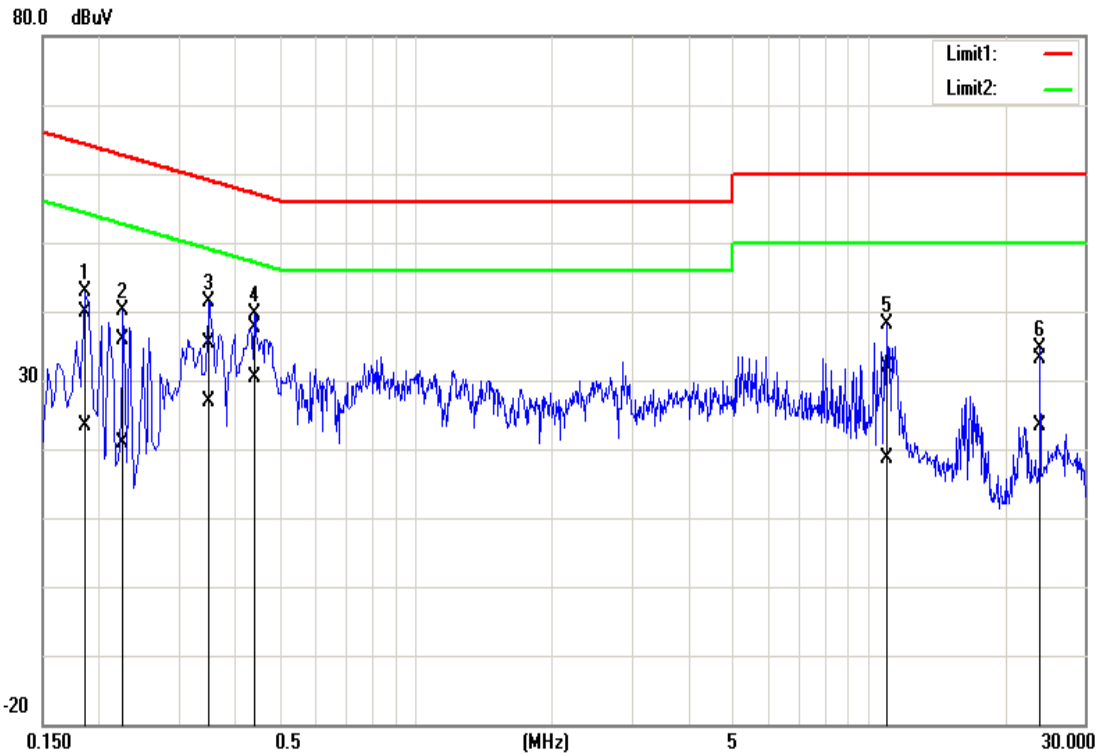

No.	Frequency (MHz)	QuasiPeak reading (dBuV)	Average reading (dBuV)	Correction factor (dB)	QuasiPeak result (dBuV)	Average result (dBuV)	QuasiPeak limit (dBuV)	Average limit (dBuV)	QuasiPeak margin (dB)	Average margin (dB)	Remark
1	0.1860	39.68	23.34	0.13	39.81	23.47	64.21	54.21	-24.40	-30.74	Pass
2	0.2260	35.75	20.75	0.13	35.88	20.88	62.60	52.60	-26.72	-31.72	Pass
3	0.3500	35.36	26.73	0.13	35.49	26.86	58.96	48.96	-23.47	-22.10	Pass
4*	0.4420	37.40	30.18	0.13	37.53	30.31	57.02	47.02	-19.49	-16.71	Pass
5	11.0060	31.56	18.38	0.32	31.88	18.70	60.00	50.00	-28.12	-31.30	Pass
6	23.9980	32.53	22.94	0.53	33.06	23.47	60.00	50.00	-26.94	-26.53	Pass

Report No.: T180420W02-RP

## 4.2 6DB BANDWIDTH AND OCCUPIED BANDWIDTH (99%)

### 4.2.1 Test Limit

According to §15.247(a)(2)

**6 dB Bandwidth** :

Limit	Shall be at least 500kHz
-------	--------------------------

**Occupied Bandwidth(99%)** : For reporting purposes only.

### 4.2.2 Test Procedure

Test method Refer as KDB 558074 D01 v04, Section 8.1 and ANSI 63.10:2013 clause 6.9.2,

1. The EUT RF output connected to the spectrum analyzer by RF cable.
2. Setting maximum power transmit of EUT
3. SA set RBW = 100KHz, VBW = 300KHz and Detector = Peak, to measurement 6dB Bandwidth
4. SA set RBW = 1% ~ 5% OBW, VBW = three times the RBW and Detector = Peak, to measurement 99% Bandwidth
5. Measure and record the result of 6 dB Bandwidth and 99% Bandwidth. in the test report.

### 4.2.3 Test Setup

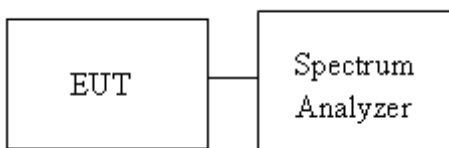



Report No.: T180420W02-RP

#### 4.2.4 Test Result

Test mode: IEEE 802.11b mode / 2412-2462 MHz						
Channel	Frequency (MHz)	Chain 0 OBW(99%) (MHz)	Chain 1 OBW(99%) (MHz)	Chain 0 6dB BW (MHz)	Chain 1 6dB BW (MHz)	6dB limit (kHz)
Low	2412	15.2387	--	9.5652	--	≥500
Mid	2437	15.2387	--	10.087	--	
High	2462	15.2387	--	9.6087	--	

Test mode: IEEE 802.11g mode / 2412-2462 MHz						
Channel	Frequency (MHz)	Chain 0 OBW(99%) (MHz)	Chain 1 OBW(99%) (MHz)	Chain 0 6dB BW (MHz)	Chain 1 6dB BW (MHz)	6dB limit (kHz)
Low	2412	16.5412	--	16.3043	--	≥500
Mid	2437	16.5412	--	16.3043	--	
High	2462	16.5412	--	16.3043	--	

Test mode: IEEE 802.11n HT 20 MHz mode / 2412-2462 MHz						
Channel	Frequency (MHz)	Chain 0 OBW(99%) (MHz)	Chain 1 OBW(99%) (MHz)	Chain 0 6dB BW (MHz)	Chain 1 6dB BW (MHz)	6dB limit (kHz)
Low	2412	17.5397	--	16.9565	--	≥500
Mid	2437	17.5397	--	17.0000	--	
High	2462	17.5397	--	17.0000	--	

Report No.: T180420W02-RP

## 6dB BW Test Data

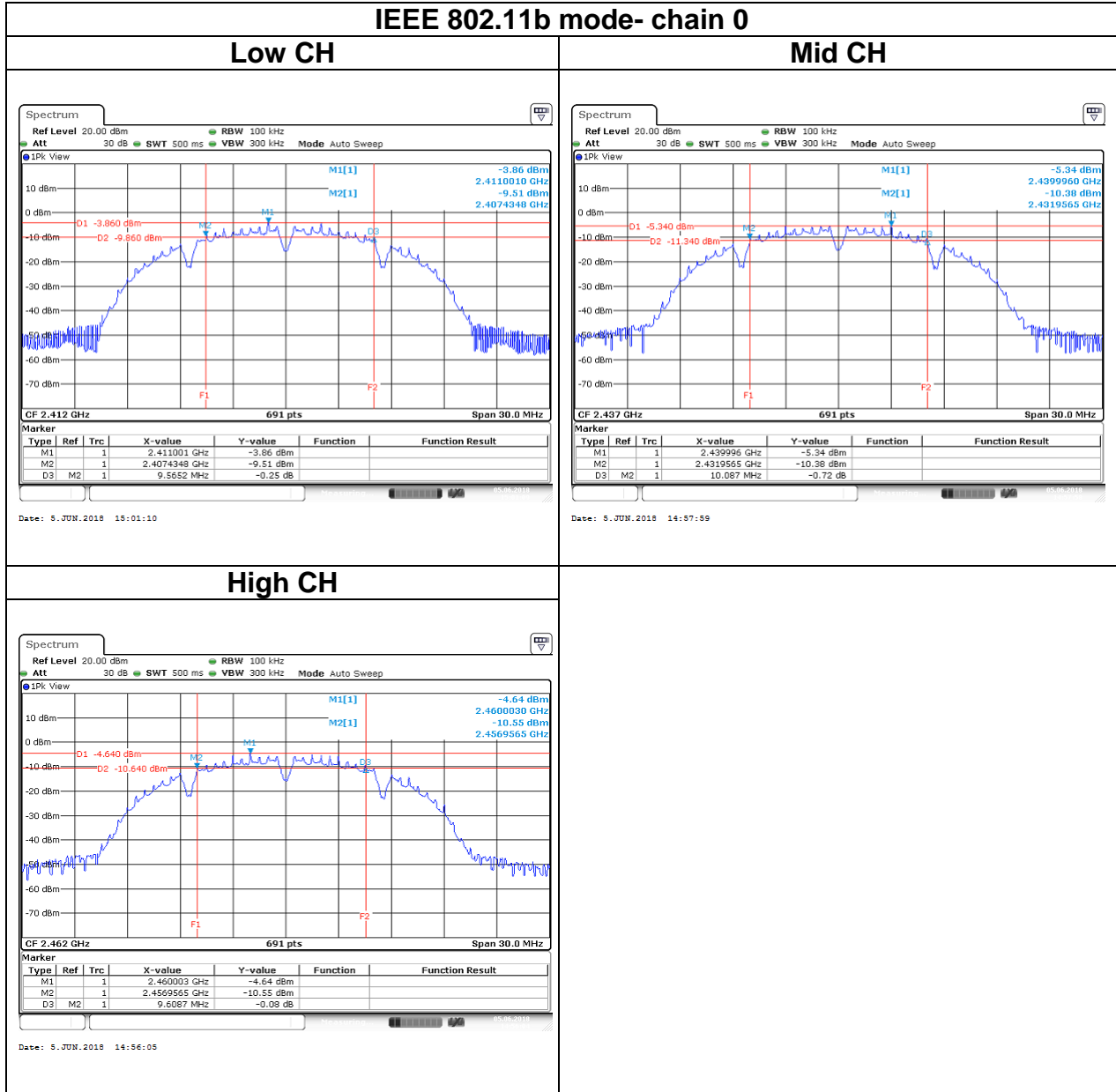

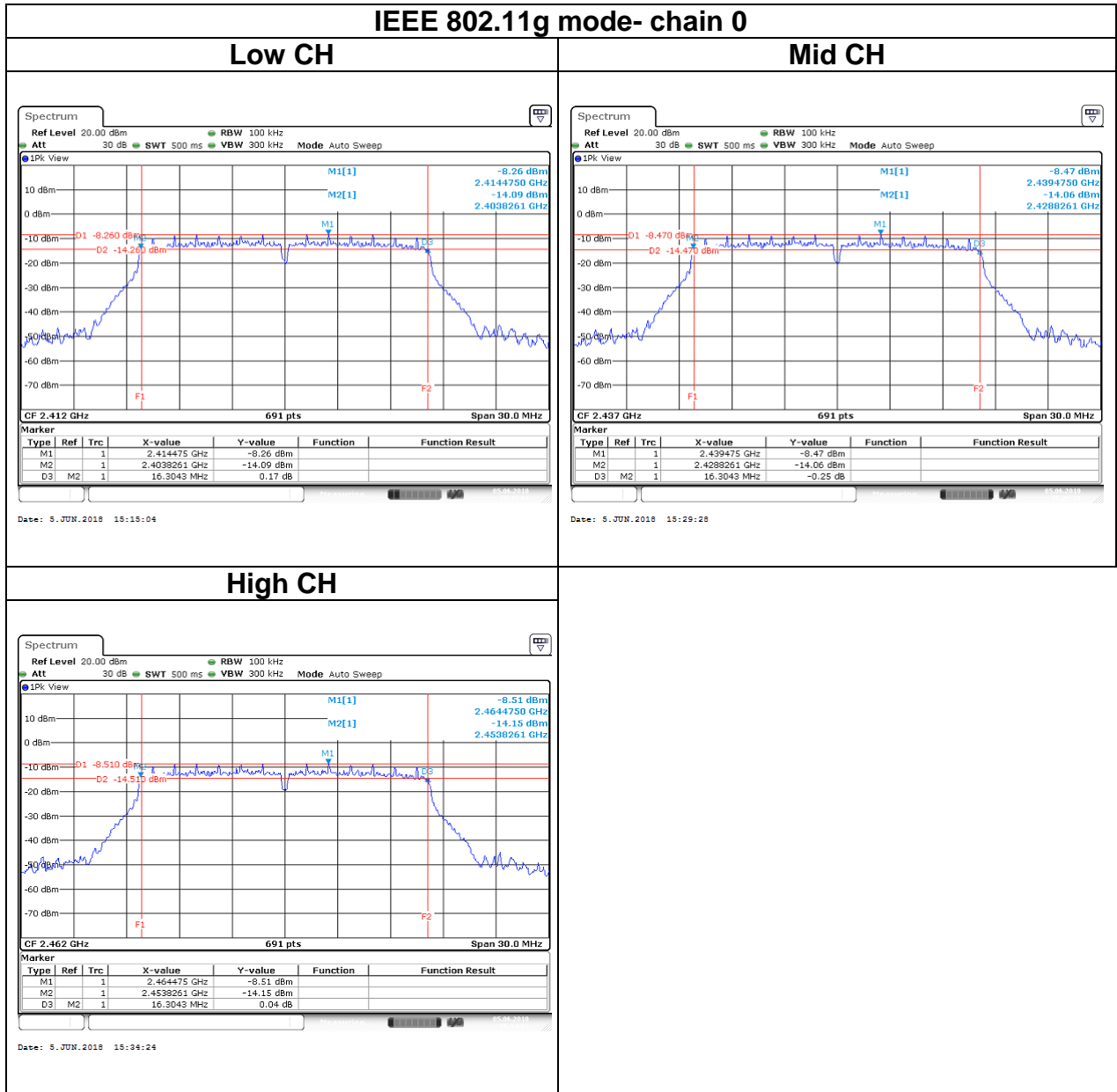

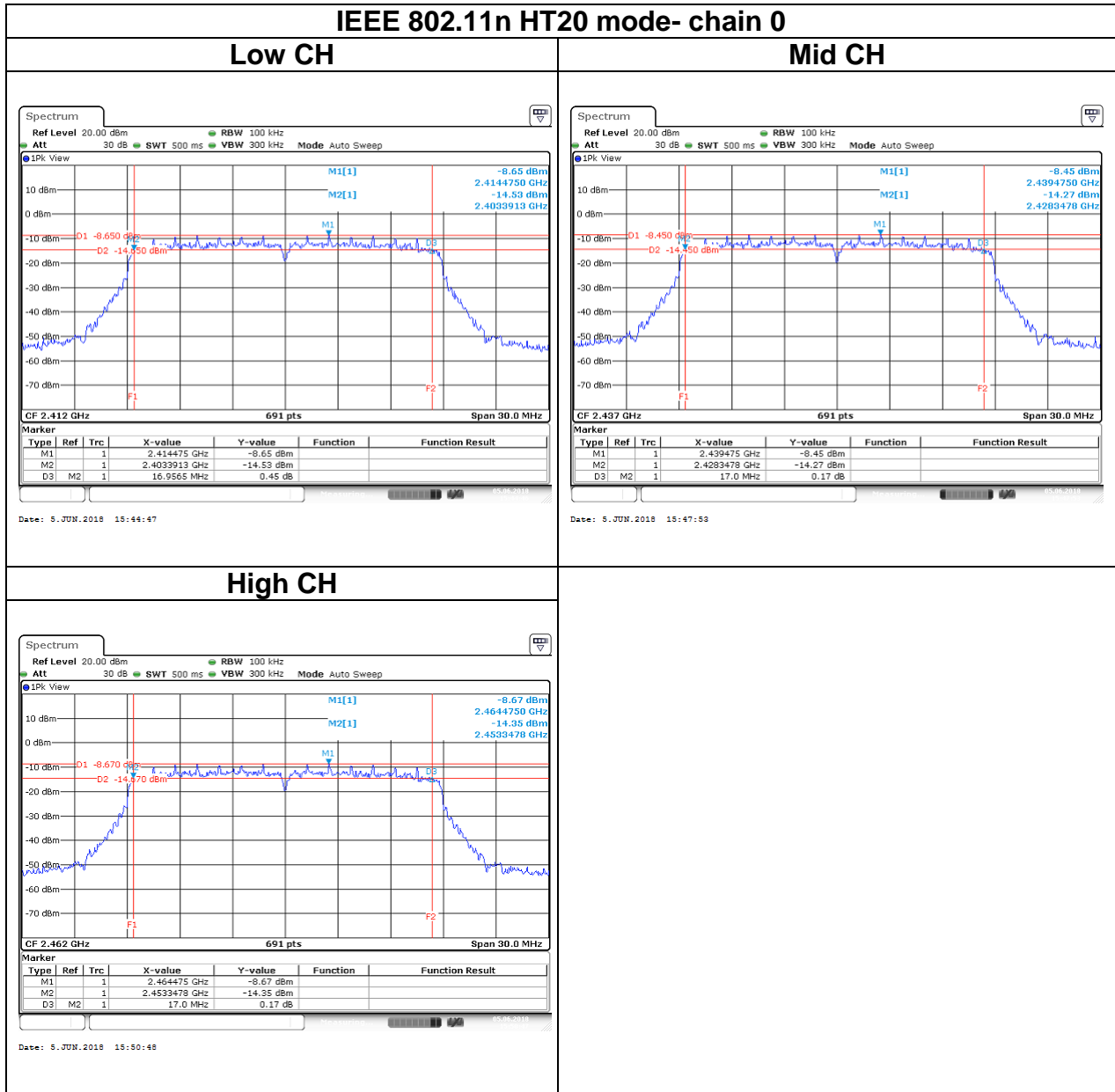

Report No.: T180420W02-RP

## OBW(99%) Test Data

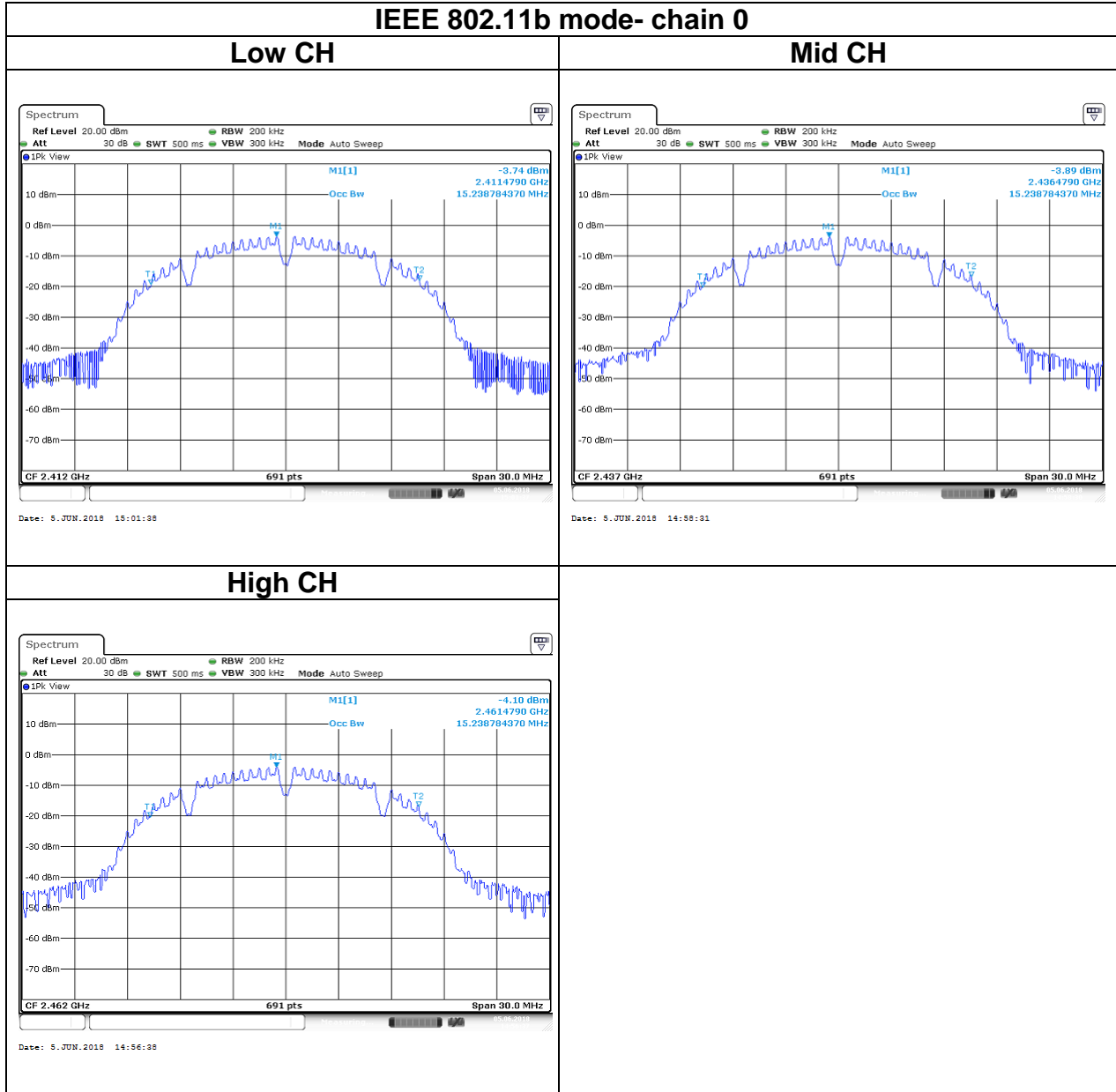

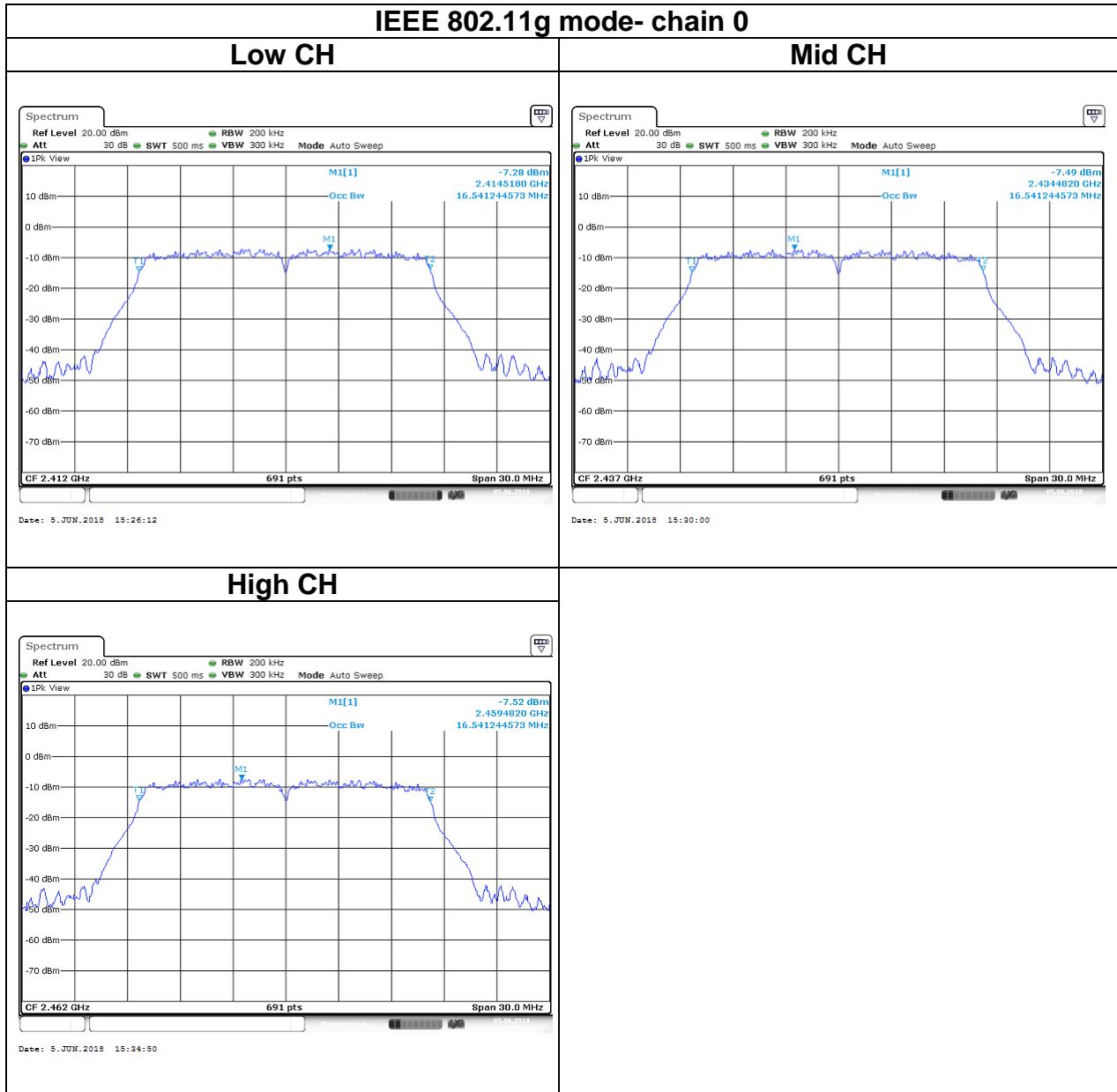

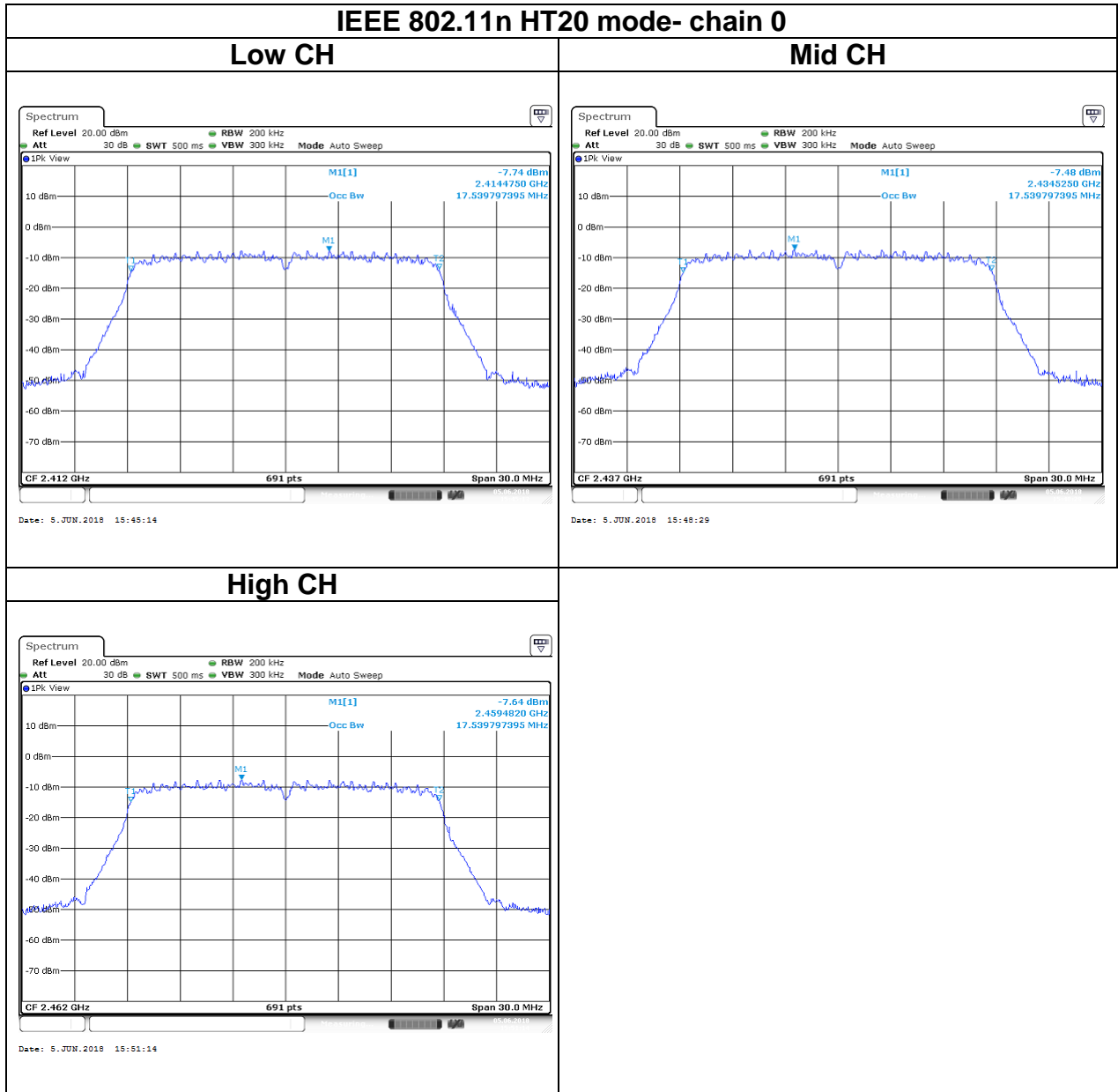

Report No.: T180420W02-RP

## 4.3 OUTPUT POWER MEASUREMENT

### 4.3.1 Test Limit

According to §15.247(b)

#### Peak output power :

For systems using digital modulation in the 2400-2483.5 MHz, and 5725-5850 MHz bands: 1 Watt(30 dBm), base on the use of antennas with directional gain not exceed 6 dBi If transmitting antennas of directional gain greater than 6dBi are used the peak output power the conducted output power from the intentional radiator shall be reduced by the amount in dB that the directional gain of the antenna exceeds 6 dBi. In case of point-to-point operation, the limit has to be reduced by 1dB for every 3 dB that the directional gain of the antenna exceeds 6 dBi.

Limit	<input checked="" type="checkbox"/> Antenna not exceed 6 dBi : 30dBm <input type="checkbox"/> Antenna with DG greater than 6 dBi : [Limit = 30 – (DG – 6)] <input type="checkbox"/> Point-to-point operation :
-------	---

Average output power : For reporting purposes only.

### 4.3.2 Test Procedure

Test method Refer as KDB 558074 D01 v04, Section 9.1.2.

1. The EUT RF output connected to the power meter by RF cable.
2. Setting maximum power transmit of EUT.
3. The path loss was compensated to the results for each measurement.
4. Measure and record the result of Peak output power and Average output power. in the test report.

### 4.3.3 Test Setup

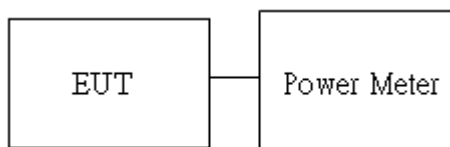



Report No.: T180420W02-RP

### 4.3.4 Test Result

#### Peak output power :

WIFI 2.4G									
Config	CH	Freq. (MHz)	Power Set		PK Power (dBm)		PK Total Power (dBm)	PK Total Power (W)	Limit
			Chain 0	Chain 1	Chain 0	Chain 1			
IEEE 802.11b Data rate: 1Mbps	Low	2412	default	--	17.62	--	17.62	0.05781	30
	Mid	2437	default	--	17.60	--	17.60	0.05754	
	High	2462	default	--	17.66	--	17.66	0.05834	
IEEE 802.11g Data rate: 6Mbps	Low	2412	default	--	22.76	--	22.76	0.18880	
	Mid	2437	default	--	22.82	--	22.82	0.19143	
	High	2462	default	--	22.76	--	22.76	0.18880	
IEEE 802.11n HT 20 Data rate: MCS 0	Low	2412	default	--	22.45	--	22.45	0.17579	
	Mid	2437	default	--	22.39	--	22.39	0.17338	
	High	2462	default	--	22.43	--	22.43	0.17498	

#### Average output power :

WIFI 2.4G					
Config	CH	Freq. (MHz)	AV Power (dBm)		AV Total Power (dBm)
			Chain 0	Chain 1	
IEEE 802.11b Data rate: 1Mbps	Low	2412	15.54	--	15.54
	Mid	2437	15.50	--	15.50
	High	2462	15.54	--	15.54
IEEE 802.11g Data rate: 6Mbps	Low	2412	13.55	--	13.55
	Mid	2437	13.61	--	13.61
	High	2462	13.39	--	13.39
IEEE 802.11n HT 20 Data rate: MCS 0	Low	2412	13.65	--	13.65
	Mid	2437	13.43	--	13.43
	High	2462	13.39	--	13.39

Report No.: T180420W02-RP

## 4.4 POWER SPECTRAL DENSITY

### 4.4.1 Test Limit

According to §15.247(e)

For digitally modulated systems, the power spectral density conducted from the intentional radiator to the antenna shall not be greater than 8 dBm in any 3 kHz band during any time interval of continuous transmission.

Limit	<input checked="" type="checkbox"/> Antenna not exceed 6 dBi : 8dBm <input type="checkbox"/> Antenna with DG greater than 6 dBi : [ Limit = 8 – (DG – 6) ] <input type="checkbox"/> Point-to-point operation :
-------	---

### 4.4.2 Test Procedure

Test method Refer as KDB 558074 D01 v04, Section 10.2

1. The EUT RF output connected to the spectrum analyzer by RF cable.
2. Setting maximum power transmit of EUT
3. SA set RBW = 3kHz, VBW = 30kHz, Span = 1.5 times DTS Bandwidth (6 dB BW), Detector = Peak, Sweep Time = Auto and Trace = Max hold.
4. The path loss and Duty Factor were compensated to the results for each measurement by SA.
5. Mark the maximum level.
6. Measure and record the result of power spectral density. in the test report.

### 4.4.3 Test Setup

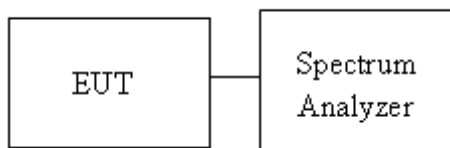

Report No.: T180420W02-RP

#### 4.4.4 Test Result

Test mode: IEEE 802.11b mode / 2412-2462 MHz					
Channel	Frequency (MHz)	Chain 0 PPSD (dBm)	Chain 1 PPSD (dBm)	Total PPSD (dBm)	Limit (dBm)
Low	2412	-10.22	-	-10.22	8
Mid	2437	-9.08	-	-9.08	
High	2462	-7.79	-	-7.79	

Test mode: IEEE 802.11g mode / 2412-2462 MHz					
Channel	Frequency (MHz)	Chain 0 PPSD (dBm)	Chain 1 PPSD (dBm)	Total PPSD (dBm)	Limit (dBm)
Low	2412	-11.36	-	-11.36	8
Mid	2437	-12.41	-	-12.41	
High	2462	-11.24	-	-11.24	

Test mode: IEEE 802.11n HT 20 MHz mode / 2412-2462 MHz					
Channel	Frequency (MHz)	Chain 0 PPSD (dBm)	Chain 1 PPSD (dBm)	Total PPSD (dBm)	Limit (dBm)
Low	2412	-11.90	-	-11.90	8
Mid	2437	-12.09	-	-12.09	
High	2462	-11.30	-	-11.30	

**Report No.:** T180420W02-RP  
**Test Data**

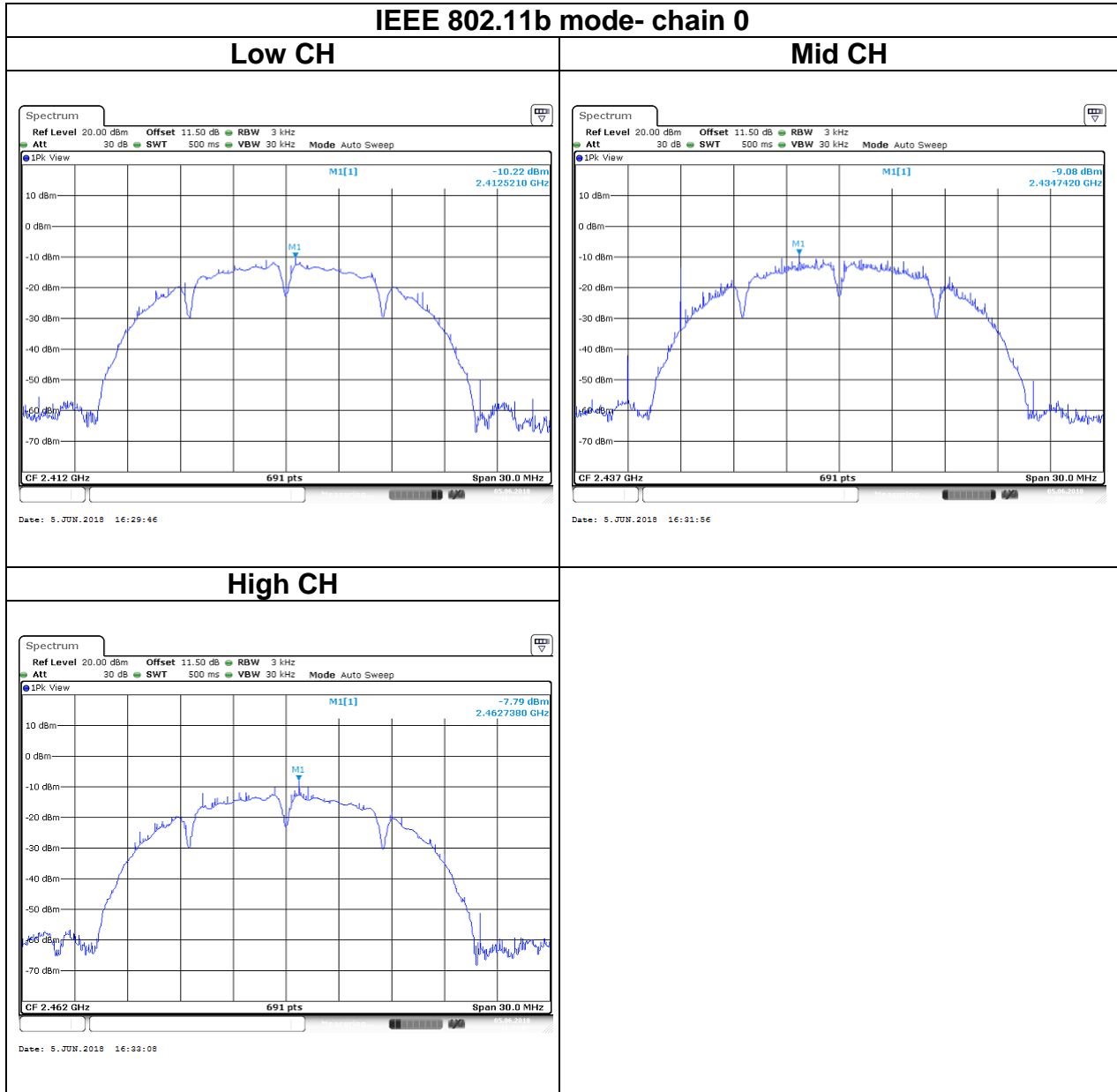

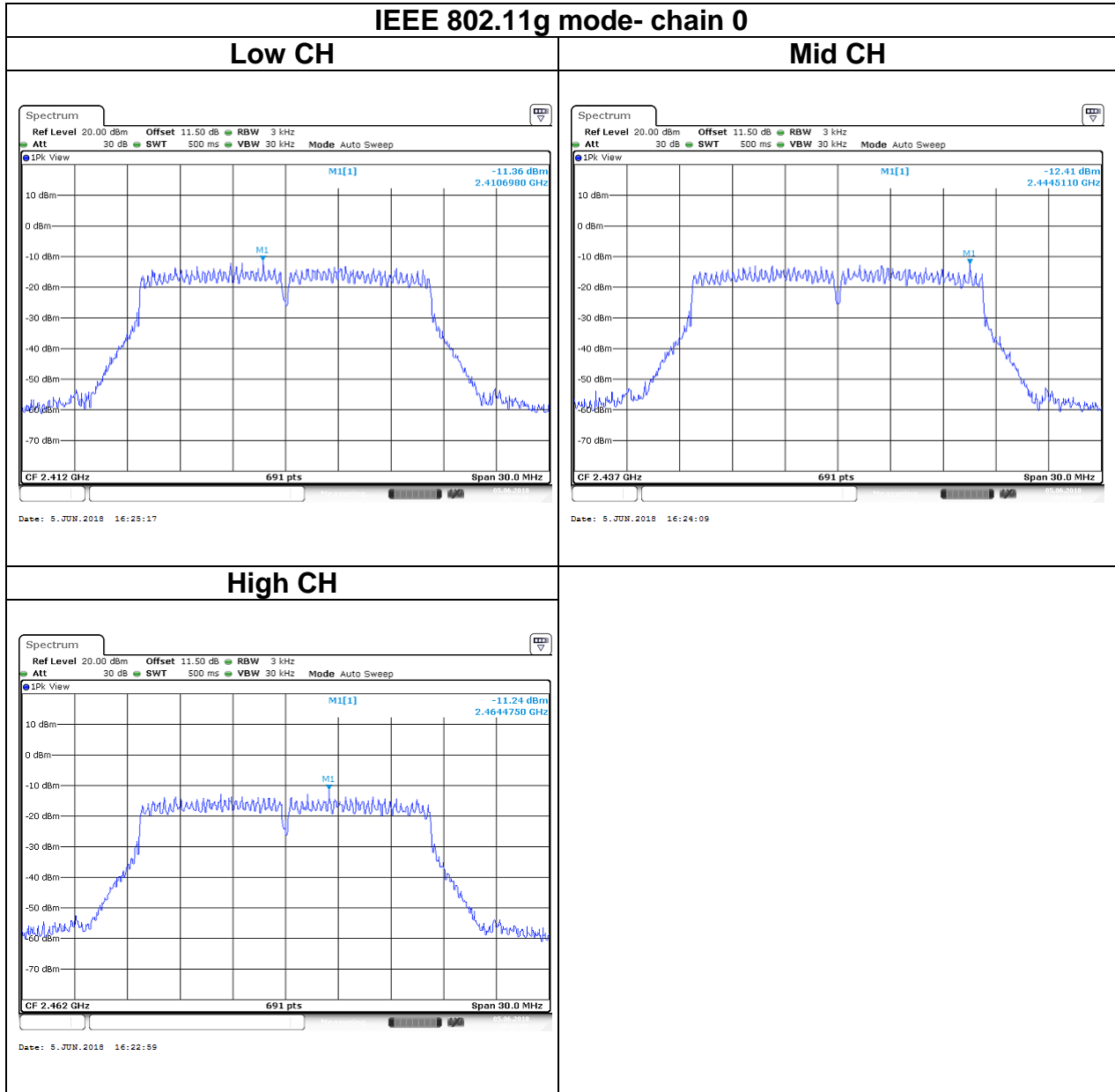

Report No.: T180420W02-RP

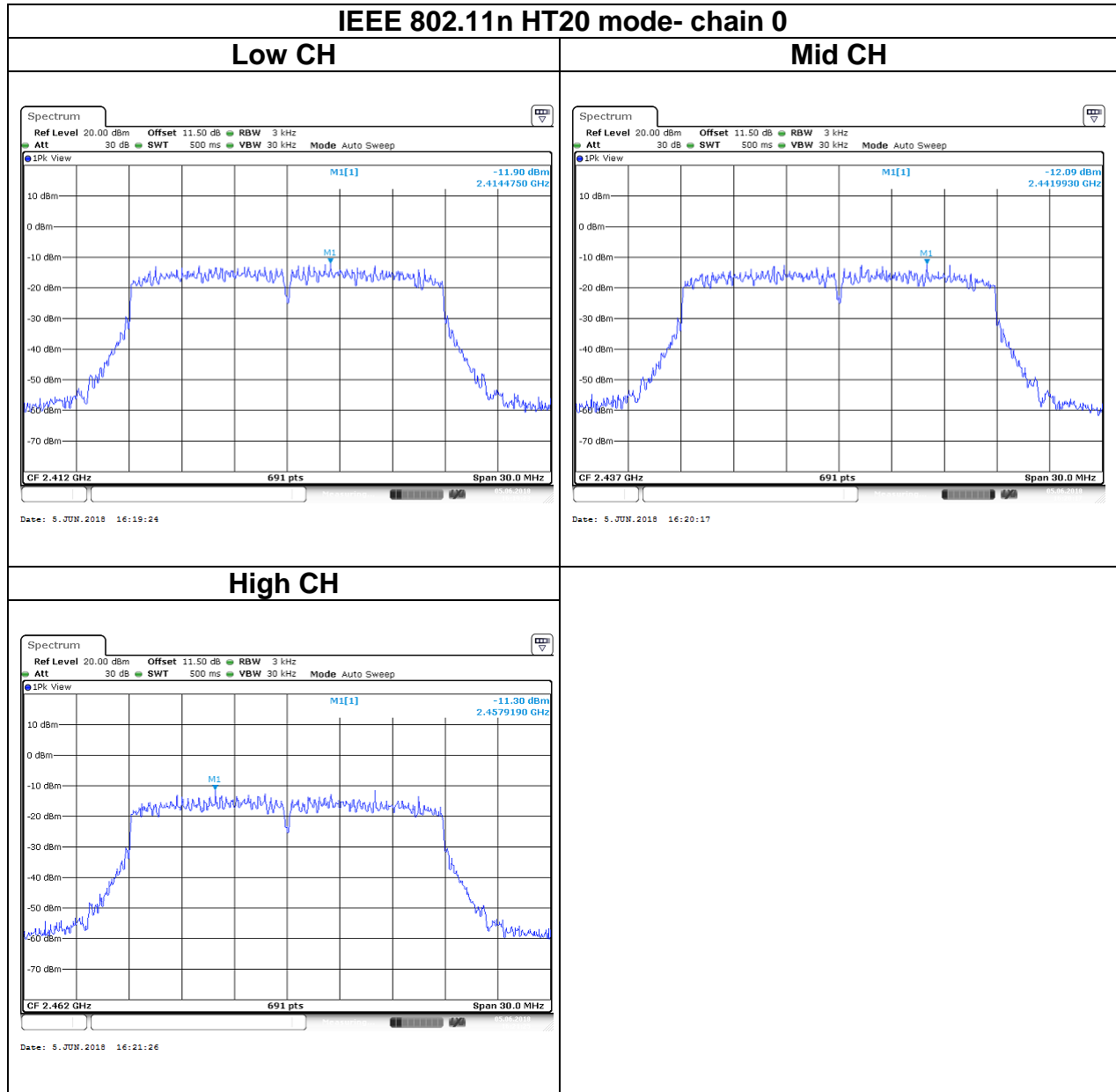

## 4.5 CONDUCTED BANDEDGE AND SPURIOUS EMISSION

### 4.5.1 Test Limit

According to §15.247(d)

In any 100 kHz bandwidth outside the authorized frequency band,

Non-restricted bands shall be attenuated at least 20 dB/30 dB relative to the maximum PSD level in 100 kHz by RF conducted or a radiated measurement which fall in the restricted bands, as defined in §15.205(a), must also comply with the radiated emission limits specified in §15.209(a).

### 4.5.2 Test Procedure

Test method Refer as KDB 558074 D01 v04, Section 11.

1. EUT RF output port connected to the SA by RF cable, and the path loss was compensated to result.
2. SA setting, RBW=100kHz, VBW=300kHz, Detector=Peak, Trace mode = max hold, SWT = Auto.
3. In any 100 kHz bandwidth outside the authorized frequency band, shall be attenuated at least 20 dB relative to the maximum in-band peak PSD level in 100 kHz when conducted power procedure is used. If the transmitter complies with the conducted power limits based on the use of RMS averaging over a time interval, the attenuation required under this paragraph shall be 30 dB instead of 20 dB.

### 4.5.3 Test Setup

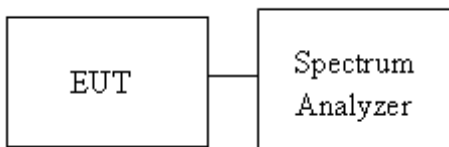

Report No.: T180420W02-RP

### 4.5.4 Test Result

#### Test Data

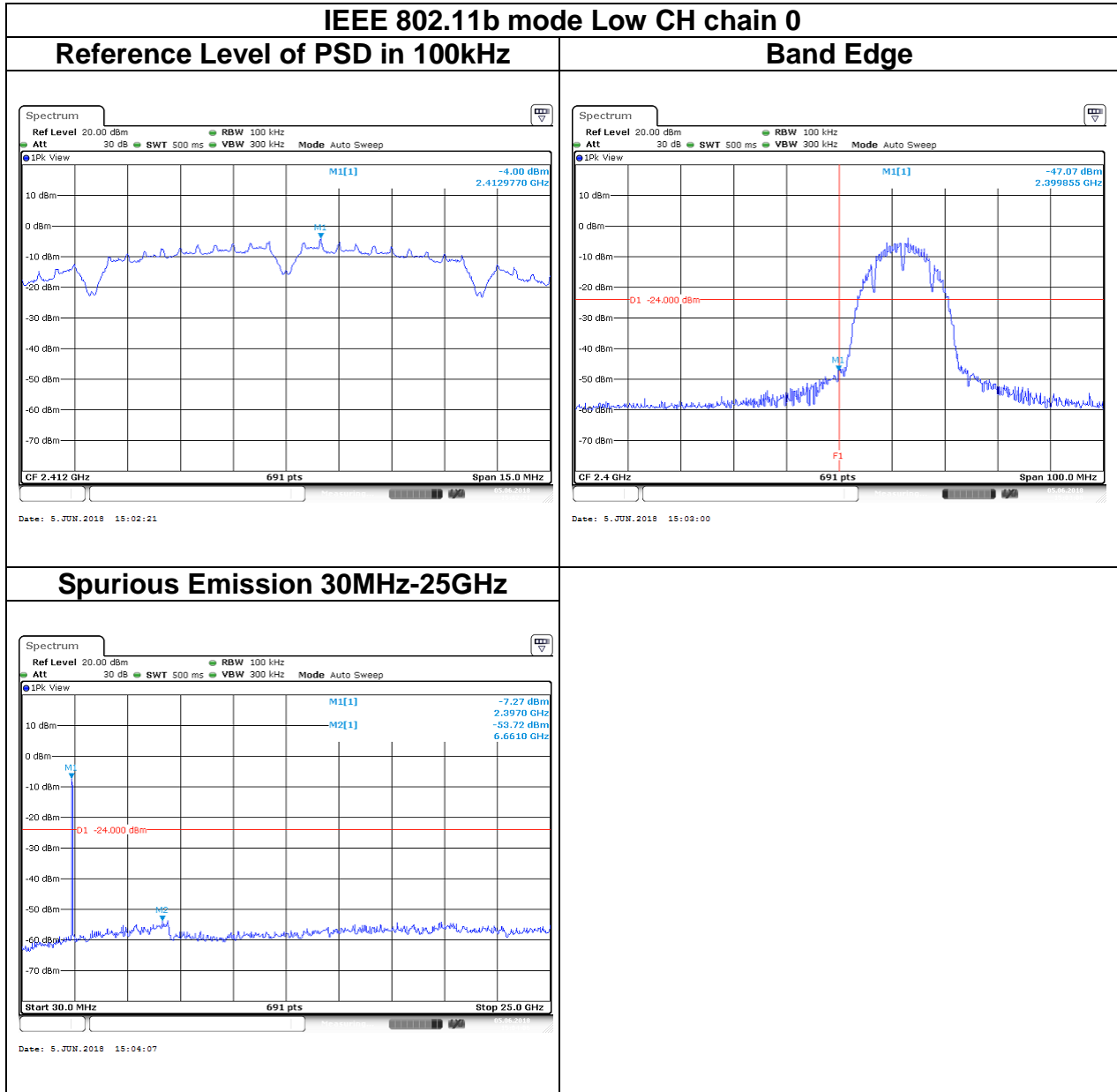



Report No.: T180420W02-RP

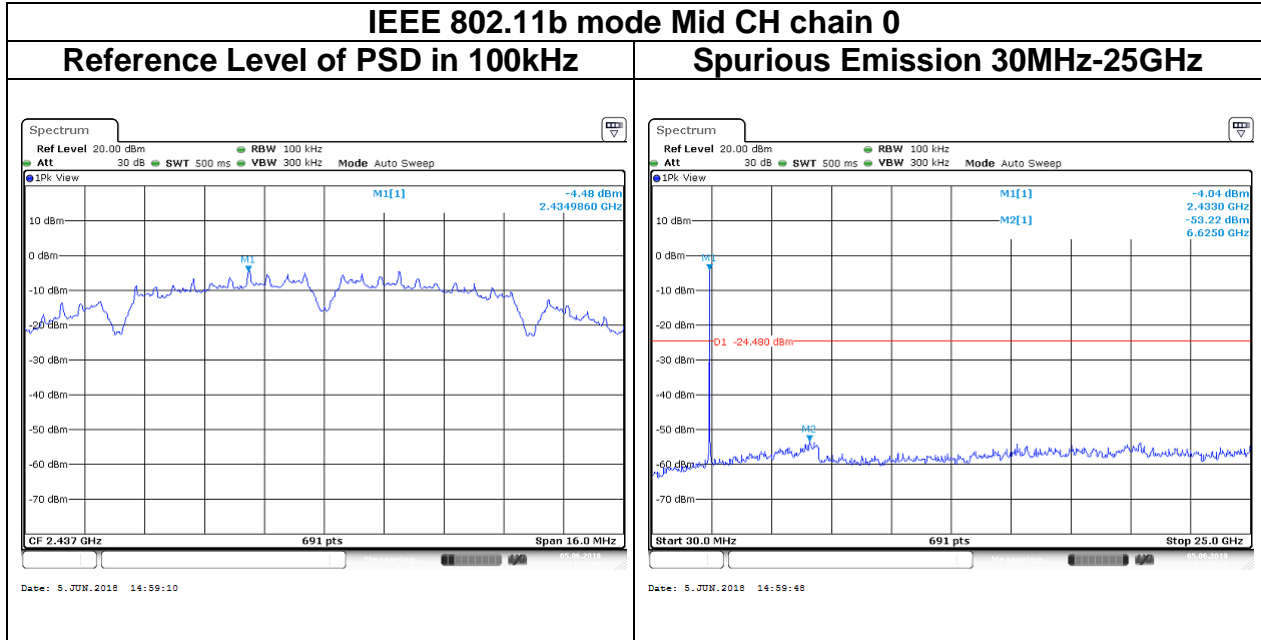

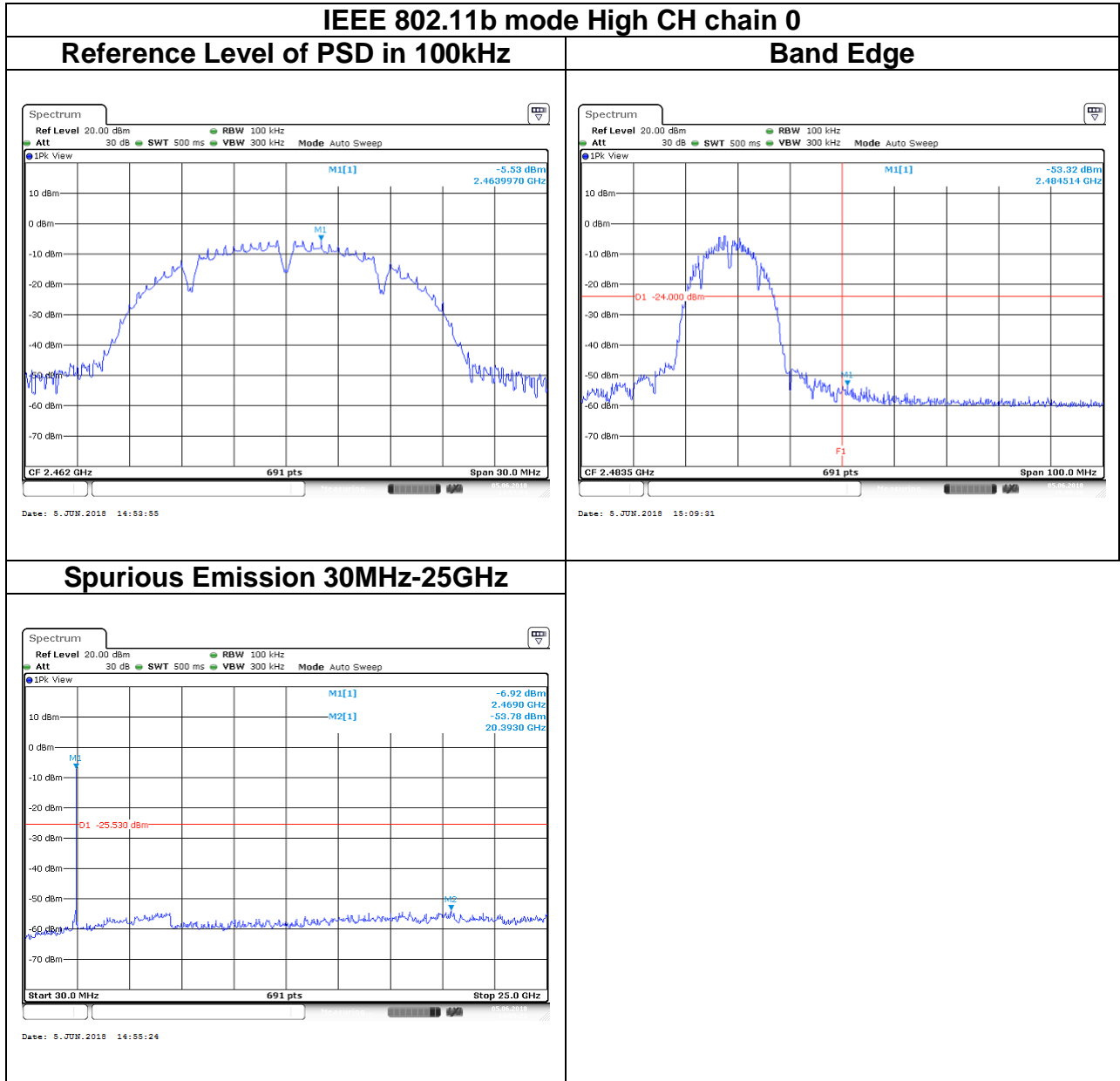

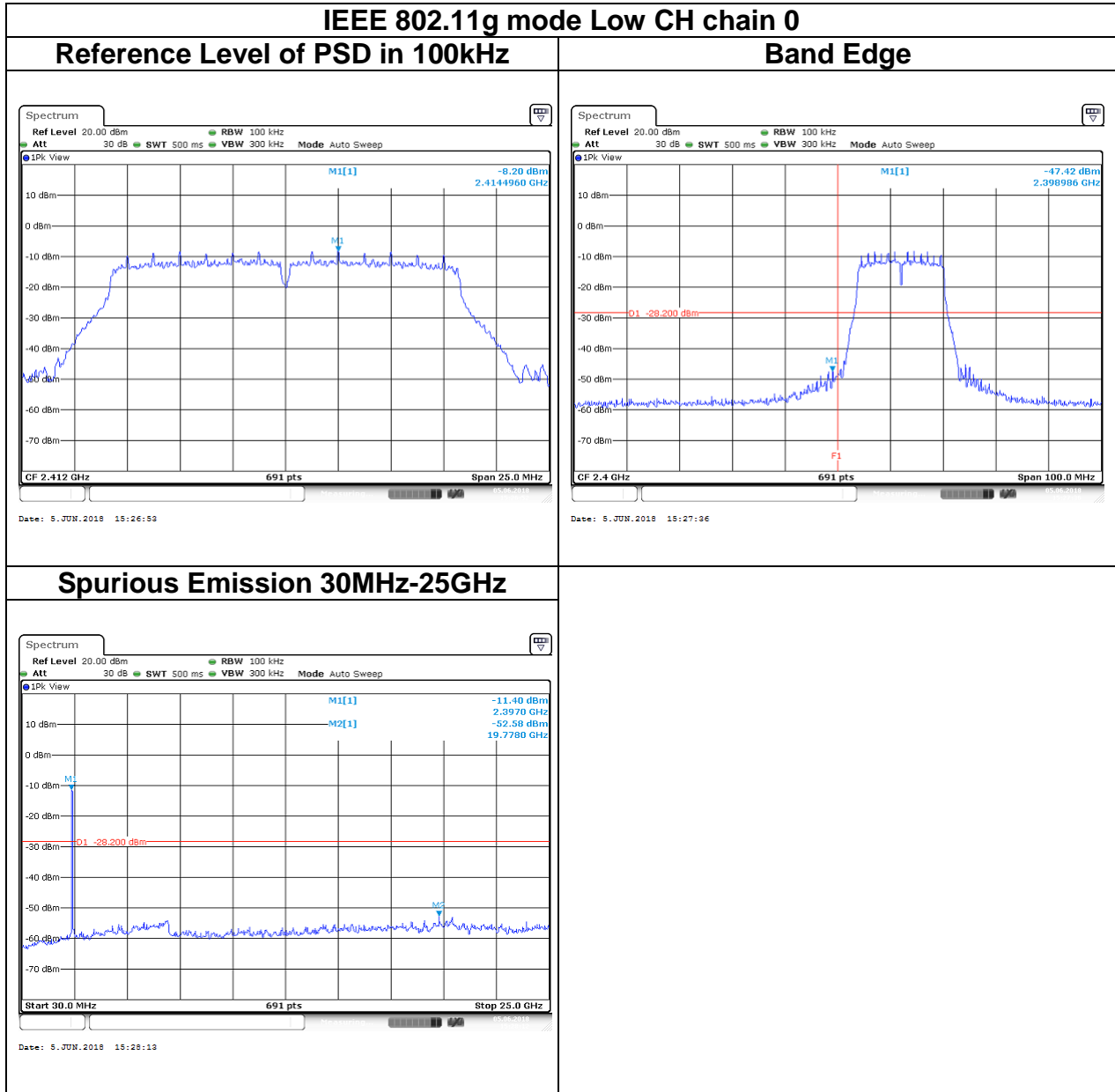

Report No.: T180420W02-RP

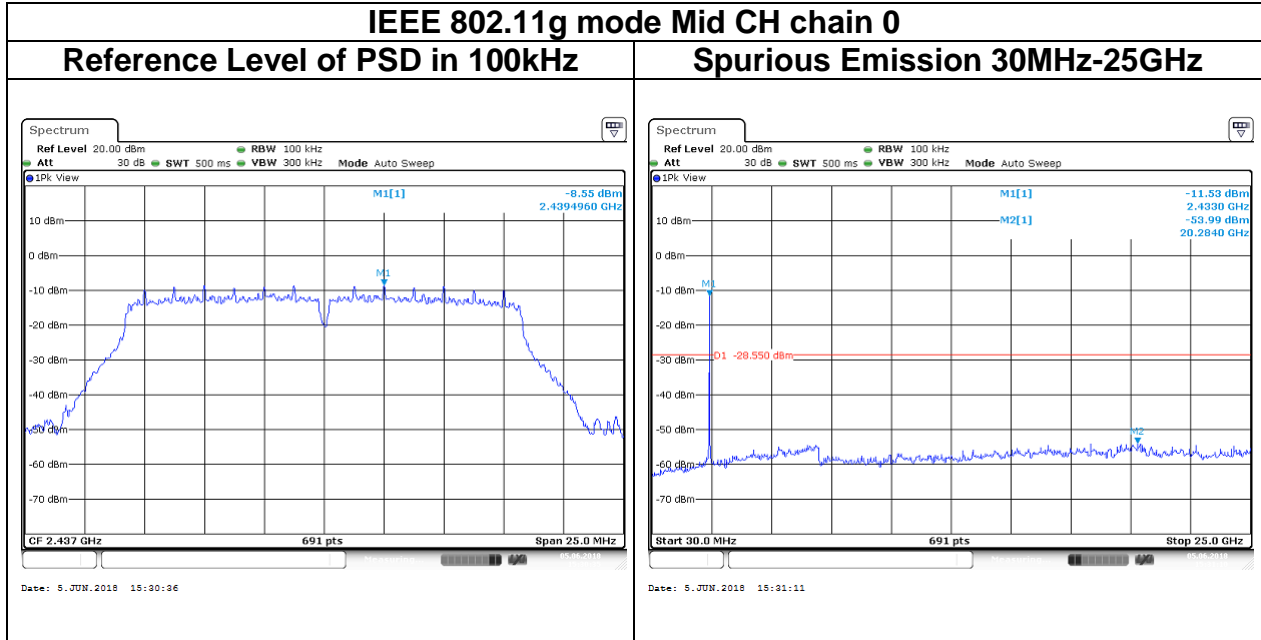

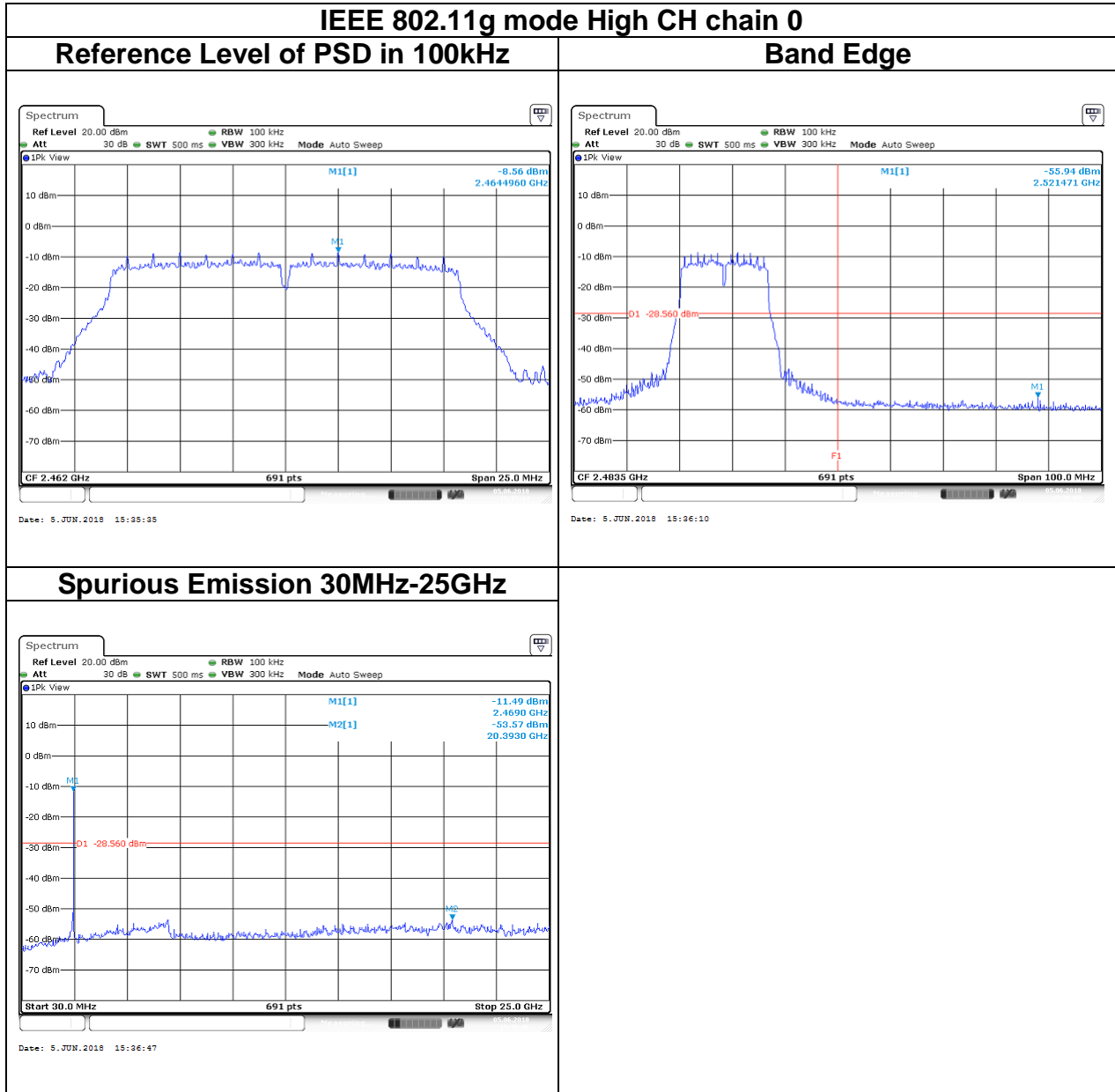

Unless otherwise stated the results shown in this test report refer only to the sample(s) tested and such sample(s) are retained for 90 days only.  
除非另有說明，此報告結果僅對測試之樣品負責，同時此樣品僅保留90天。本報告未經本公司書面許可，不可部分複製。

This document is issued by the Company subject to its General Conditions of Service printed overleaf, available on request or accessible at [www.sgs.com/terms\\_and\\_conditions.htm](http://www.sgs.com/terms_and_conditions.htm) and for electronic format documents, subject to Terms and Conditions for Electronic Documents at [www.sgs.com/terms\\_e-document.htm](http://www.sgs.com/terms_e-document.htm). Attention is drawn to the limitation of liability, indemnification and jurisdiction issues defined therein. Any holder of this document is advised that information contained hereon reflects the Company's findings at the time of its intervention only and within the limits of Client's instructions, if any. The Company's sole responsibility is to its Client and this document does not exonerate parties to a transaction from exercising all their rights and obligations under the transaction documents. This document cannot be reproduced except in full, without prior written approval of the Company. Any unauthorized alteration, forgery or falsification of the content or appearance of this document is unlawful and offenders may be prosecuted to the fullest extent of the law.

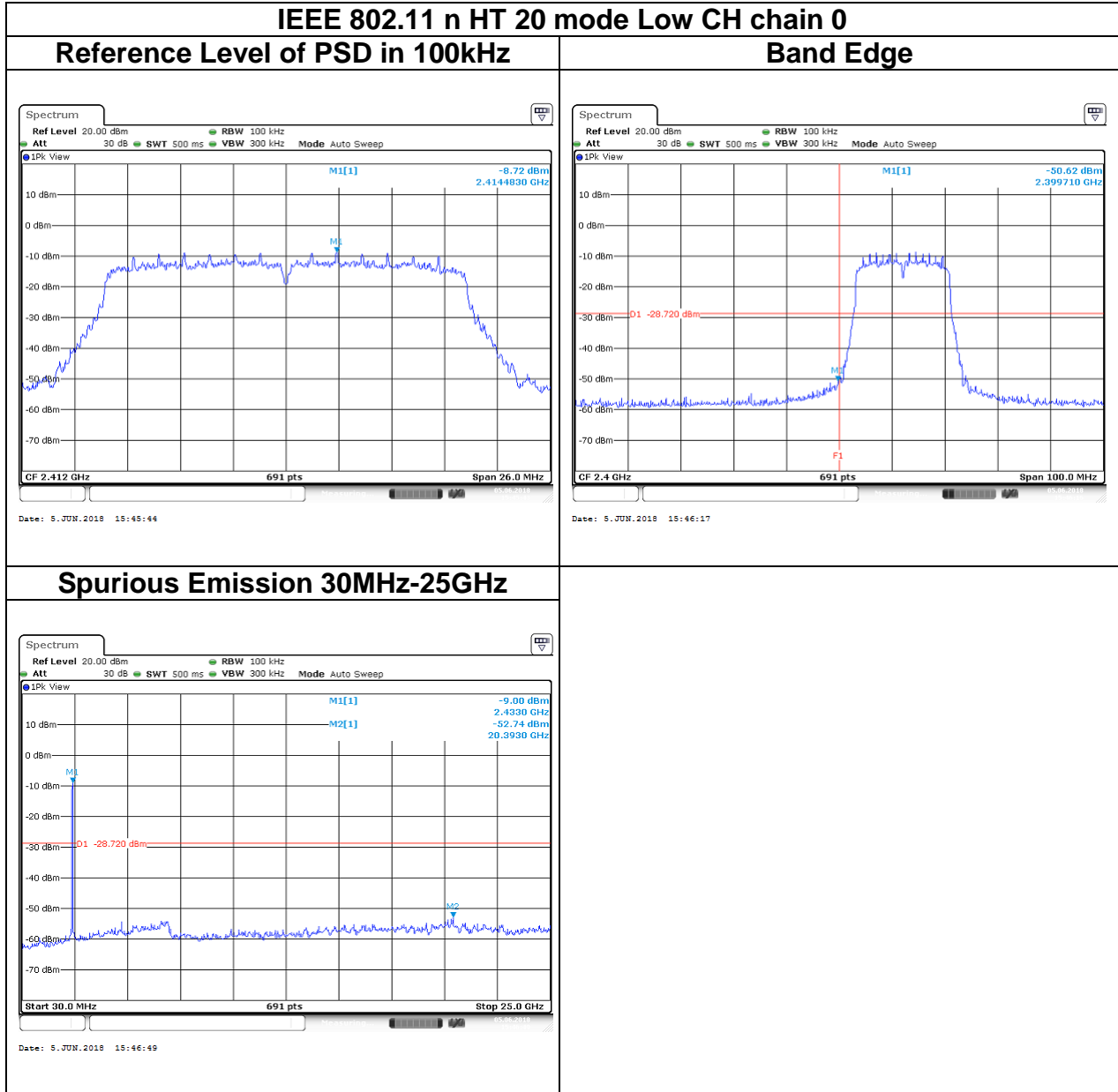

Report No.: T180420W02-RP

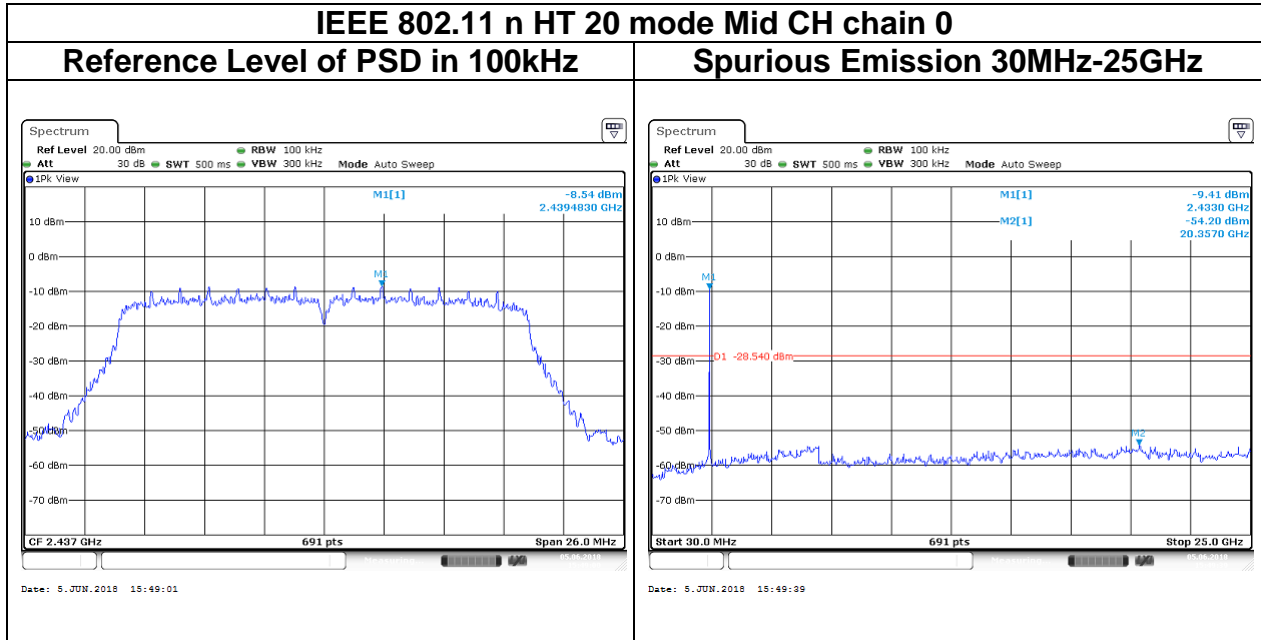

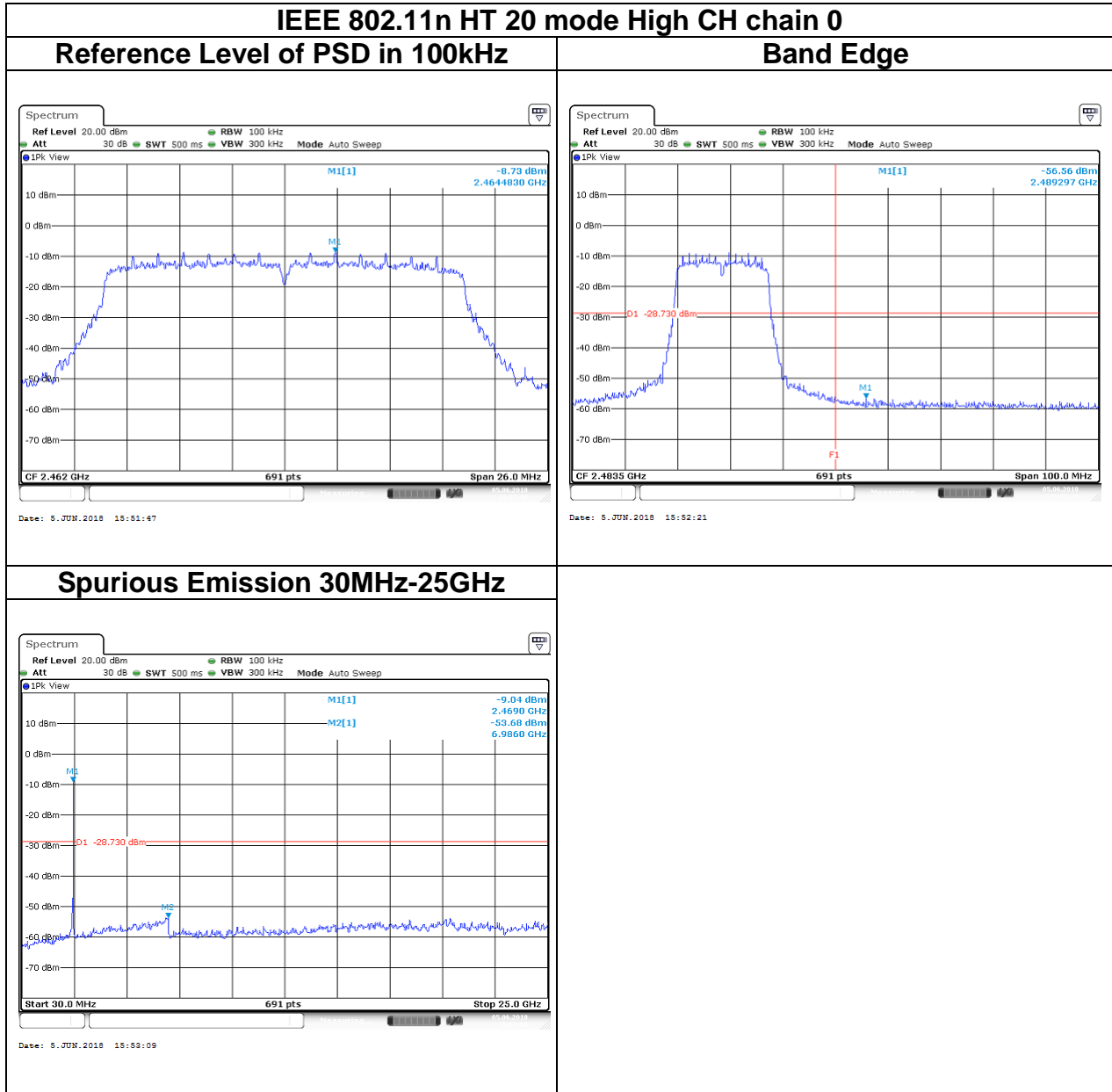



Report No.: T180420W02-RP

## 4.6 RADIATION BANDEDGE AND SPURIOUS EMISSION

### 4.6.1 Test Limit

FCC according to §15.247(d), §15.209 and §15.205,

In any 100 kHz bandwidth outside the authorized frequency band, all harmonic and spurious must be least 20 dB below the highest emission level with the authorized frequency band. Radiation emission which fall in the restricted bands must also follow the FCC section 15.209 as below limit in table.

#### Below 30 MHz

Frequency	Field Strength (microvolts/m)	Magnetic H-Field (microamperes/m)	Measurement Distance (metres)
9-490 kHz	2,400/F (F in kHz)	2,400/F (F in kHz)	300
490-1,705 kHz	24,000/F (F in kHz)	24,000/F (F in kHz)	30
1.705-30 MHz	30	N/A	30

#### Above 30 MHz

Frequency	Field Strength (microvolts/m)	Measurement Distance (metres)
30-88	100	3
88-216	150	3
216-960	200	3
Above 960	500	3

**Report No.:** T180420W02-RP

### 4.6.2 Test Procedure

Test method Refer as KDB 558074 D01 v04, Section 12.1.

1. The EUT is placed on a turntable, Above 1 GHz is 1.5m and below 1 GHz is 0.8m above ground plane. The EUT Configured un accordance with ANSI C63.10, and the EUT set in a continuous mode.

2. The turntable shall be rotated for 360 degrees to determine the position of maximum emission level. And EUT is set 3m away from the receiving antenna, which is scanned from 1m to 4m above the ground plane to find out the highest emissions. Measurement are made polarized in both the vertical and the horizontal positions with antenna.

3. Span shall wide enough to full capture the emission measured. The SA from 9kHz to 26.5GHz set to the low, Mid and High channels with the EUT transmit.

Note: No emission found between lowest internal used/generated frequency to 30MHz(9KHz~30MHz)

5. The SA setting following :

(1) Below 1G : RBW = 100kHz, VBW  $\geq$  3 RBW, Sweep = Auto, Detector = Peak, Trace = Max hold.

(2) Above 1G :

(2.1) For Peak measurement : RBW = 1MHz, VBW  $\geq$  3 RBW, Sweep = Auto, Detector = Peak, Trace = Max hold.

(2.2) For Average measurement : RBW = 1MHz, VBW

·If Duty Cycle  $\geq$  98%, VBW=10Hz.

·If Duty Cycle < 98%, VBW=1/T.

Configuration	Duty Cycle (%)	T(ms)	1/T (kHz)	VBW Setting
802.11b	100%	4.5297	-	10Hz
802.11g	97%	0.7605	1.315	300Hz
802.11n HT20	97%	0.6538	1.530	300Hz

Report No.: T180420W02-RP  
**4.6.3 Test Setup**

**9kHz ~ 30MHz**

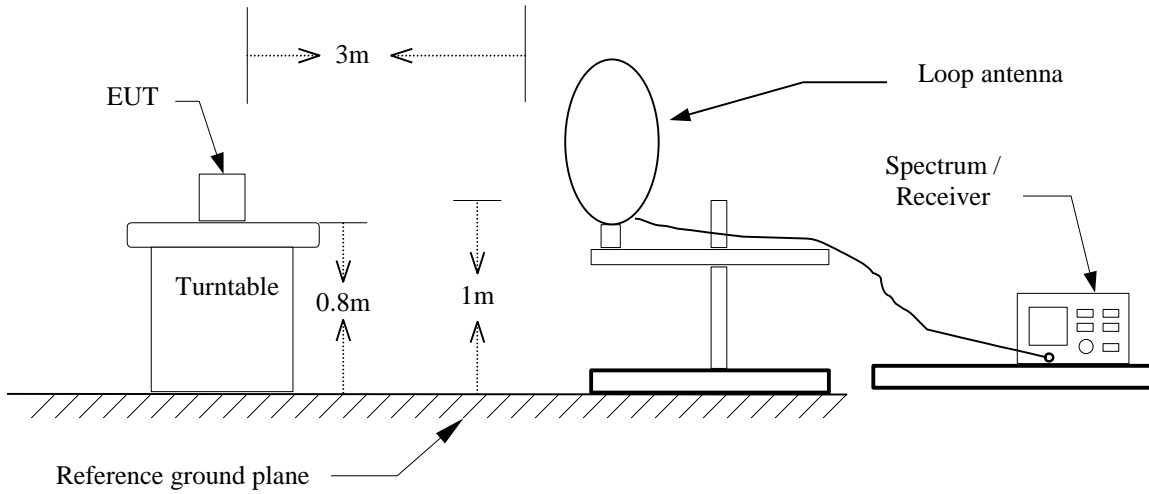

**30MHz ~ 1GHz**

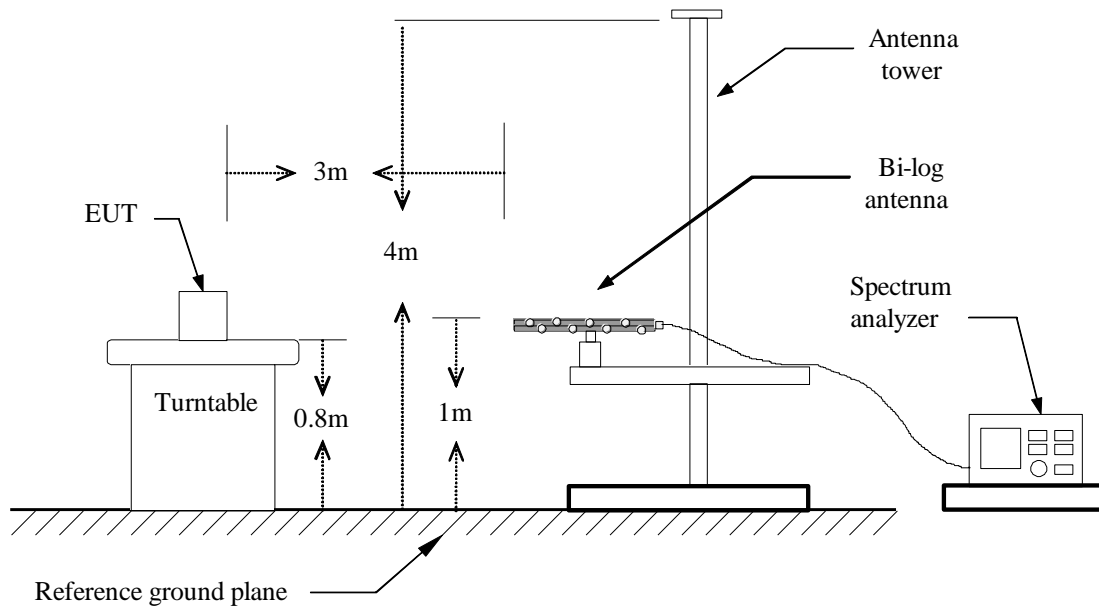

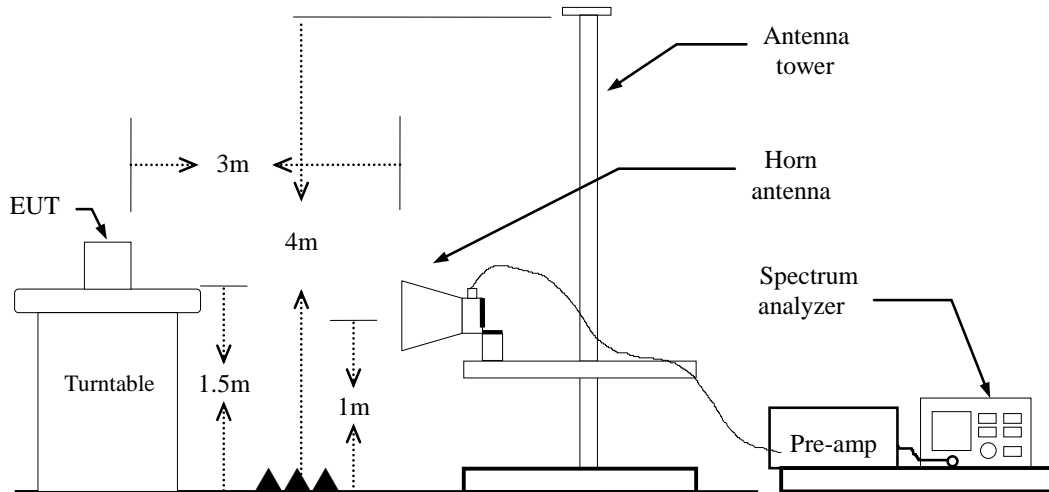

Report No.: T180420W02-RP

### 4.6.4 Test Result

#### Band Edge Test Data

Test Mode	IEEE 802.11b Low CH	Temp/Hum	22(°C) / 34%RH
Test Item	Band Edge	Test Date	June 6, 2018
Polarize	Horizontal	Test Engineer	Jerry Chuang
Detector	Peak		

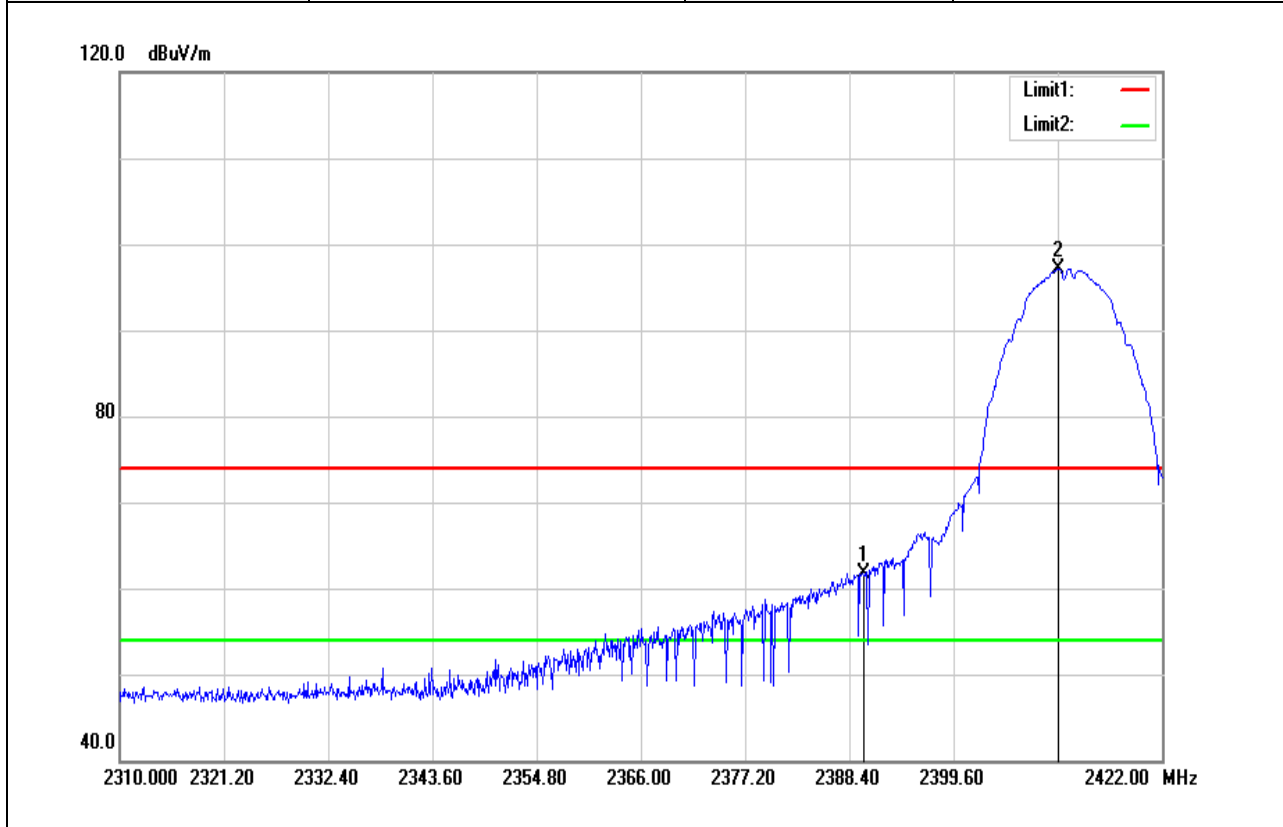

Frequency (MHz)	Reading (dBuV)	Correct Factor (dB/m)	Result (dBuV/m)	Limit (dBuV/m)	Margin (dB)	Remark
2390.000	64.60	-2.98	61.62	74.00	-12.38	peak
2410.800	99.99	-2.92	97.07	-	-	peak

Test Mode	IEEE 802.11b Low CH	Temperature:	22(°C) / 34%RH
Test Item	Band Edge	Test Date	June 6, 2018
Polarize	Horizontal	Test Engineer	Jerry Chuang
Detector	Average		

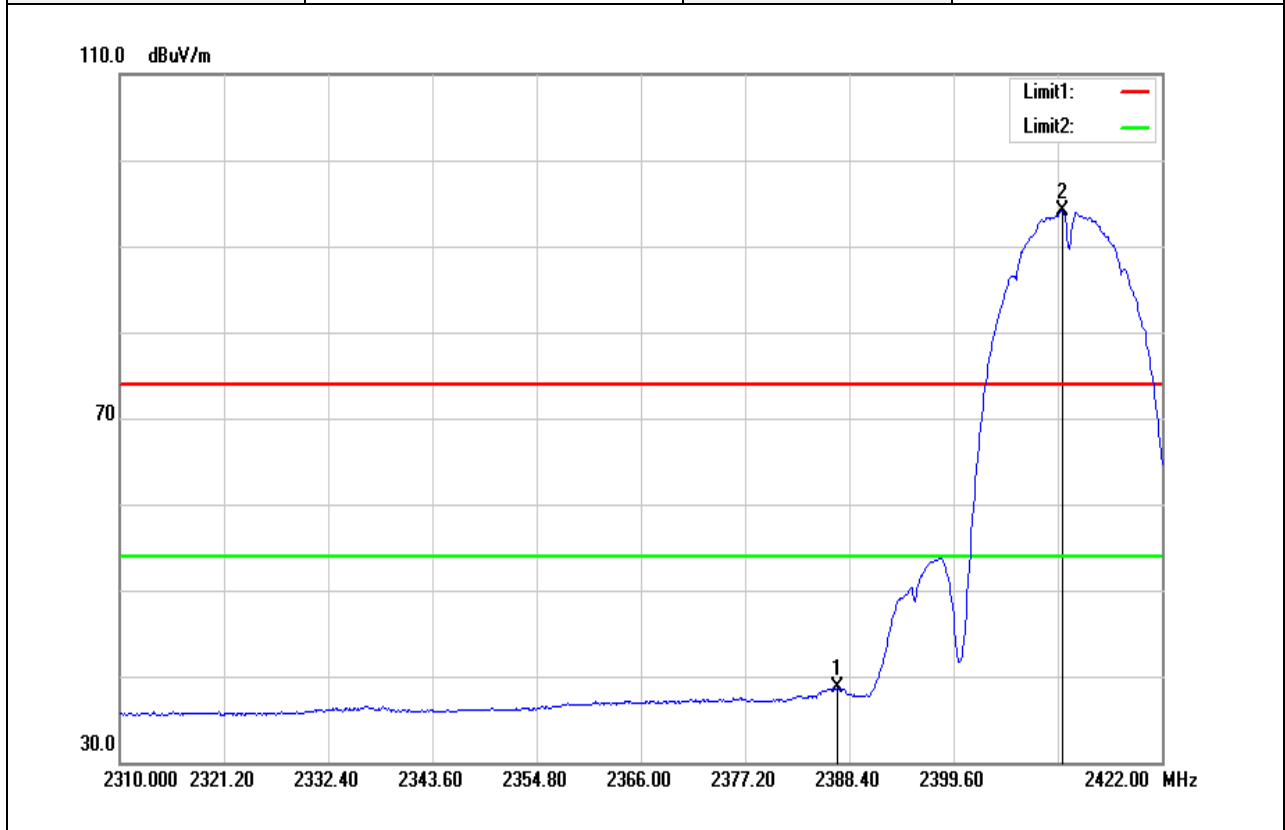

Frequency (MHz)	Reading (dBuV)	Correct Factor (dB/m)	Result (dBuV/m)	Limit (dBuV/m)	Margin (dB)	Remark
2387.168	41.66	-2.99	38.67	54.00	-15.33	AVG
2411.248	97.02	-2.92	94.10	-	-	AVG

Report No.: T180420W02-RP

Test Mode	IEEE 802.11b High CH	Temp/Hum	22(°C) / 34%RH
Test Item	Band Edge	Test Date	June 6, 2018
Polarize	Horizontal	Test Engineer	Jerry Chuang
Detector	Peak		

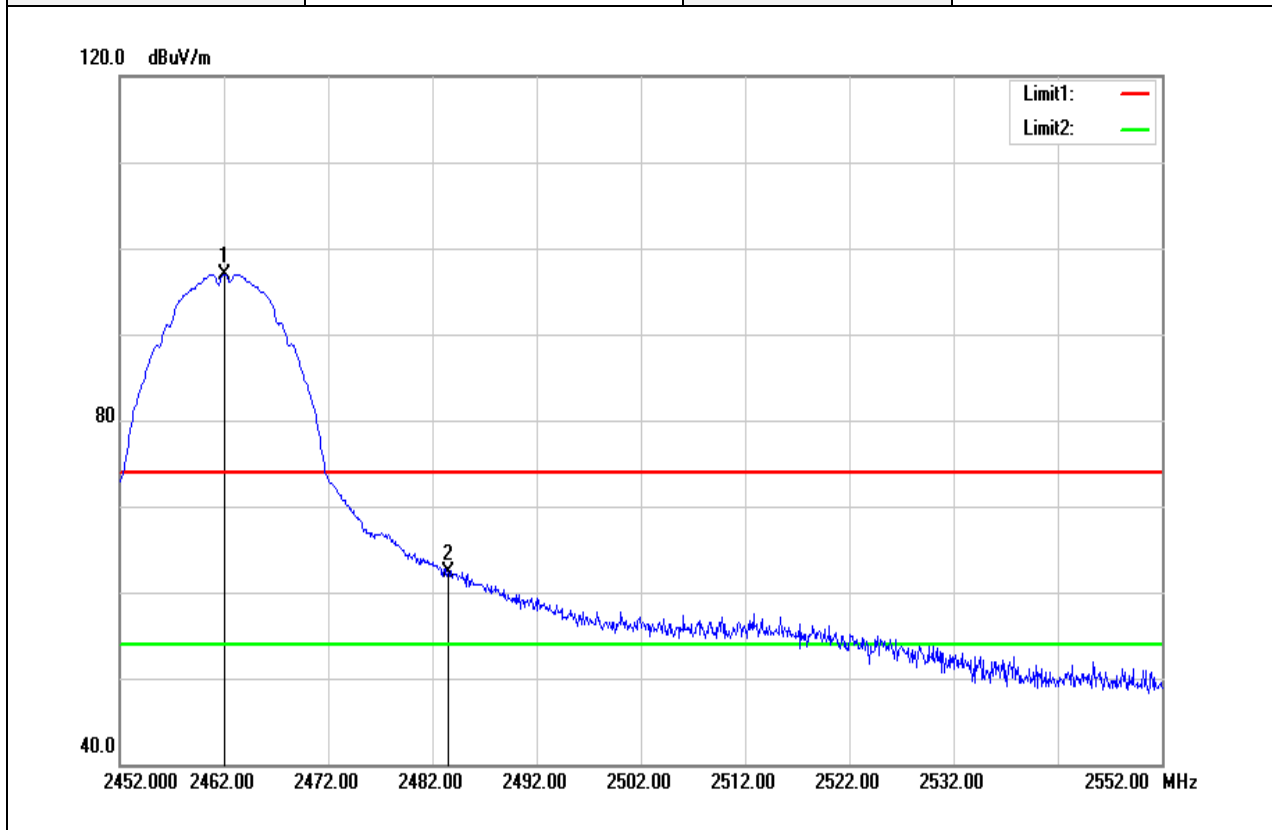

Frequency (MHz)	Reading (dBuV)	Correct Factor (dB/m)	Result (dBuV/m)	Limit (dBuV/m)	Margin (dB)	Remark
2462.000	99.75	-2.76	96.99	-	-	peak
2483.500	64.94	-2.69	62.25	74.00	-11.75	peak

Report No.: T180420W02-RP

Test Mode	IEEE 802.11b High CH	Temperature:	22(°C) / 34%RH
Test Item	Band Edge	Test Date	June 6, 2018
Polarize	Horizontal	Test Engineer	Jerry Chuang
Detector	Average		

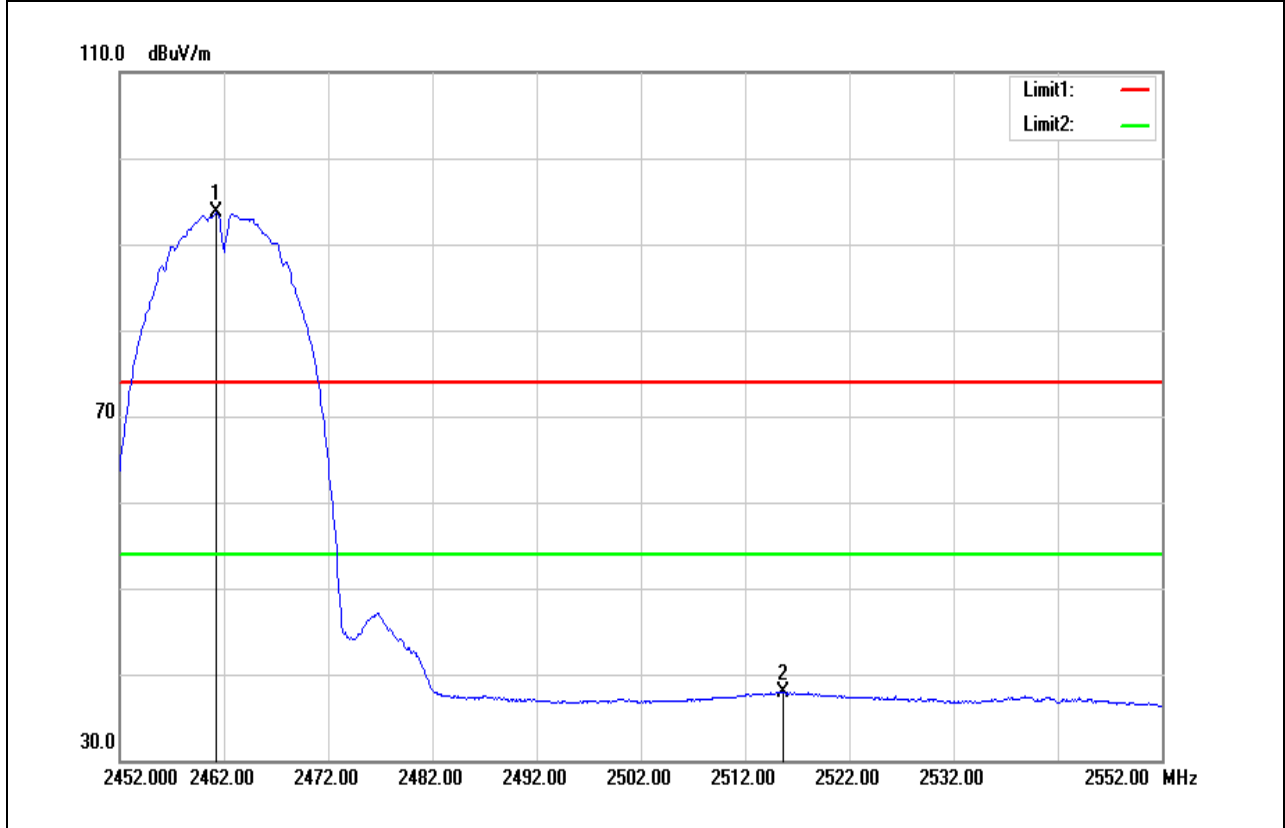

Frequency (MHz)	Reading (dBuV)	Correct Factor (dB/m)	Result (dBuV/m)	Limit (dBuV/m)	Margin (dB)	Remark
2461.300	96.43	-2.76	93.67	-	-	AVG
2515.700	40.56	-2.61	37.95	54.00	-16.05	AVG



Report No.: T180420W02-RP

Test Mode	IEEE 802.11g Low CH	Temp/Hum	22(°C) / 34%RH
Test Item	Band Edge	Test Date	June 6, 2018
Polarize	Horizontal	Test Engineer	Jerry Chuang
Detector	Peak		

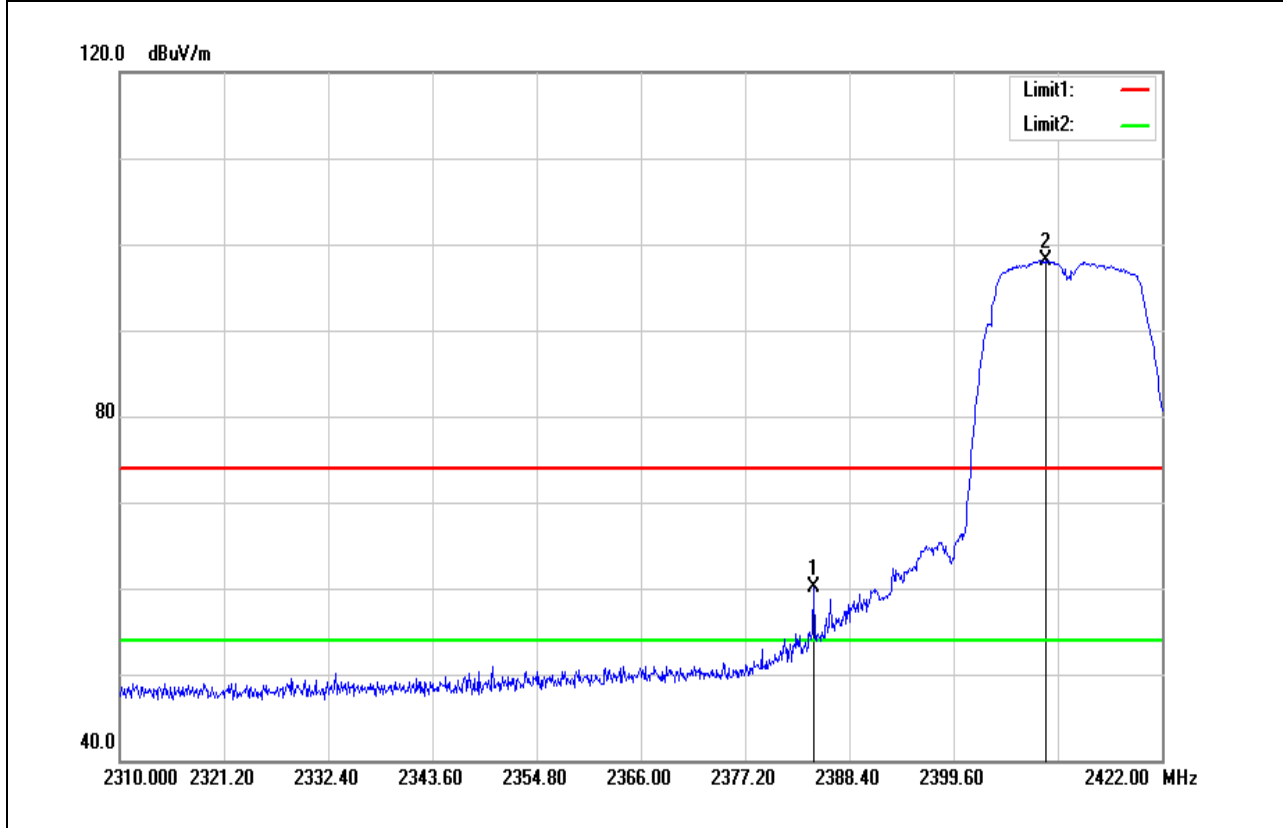

Frequency (MHz)	Reading (dBuV)	Correct Factor (dB/m)	Result (dBuV/m)	Limit (dBuV/m)	Margin (dB)	Remark
2384.592	63.15	-2.99	60.16	74.00	-13.84	peak
2409.568	101.08	-2.92	98.16	-	-	peak

Report No.: T180420W02-RP

Test Mode	IEEE 802.11g Low CH	Temperature:	22(°C) / 34%RH
Test Item	Band Edge	Test Date	June 6, 2018
Polarize	Horizontal	Test Engineer	Jerry Chuang
Detector	Average		

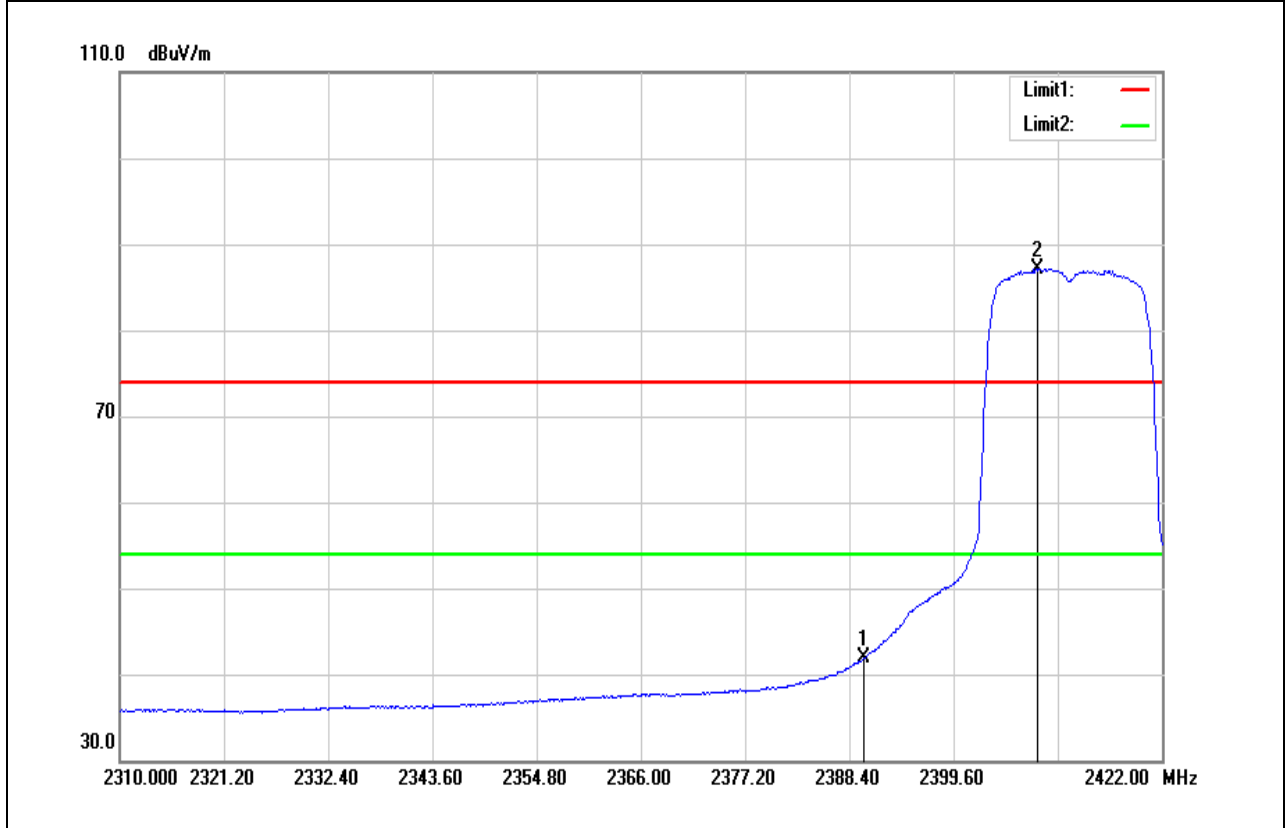

Frequency (MHz)	Reading (dBuV)	Correct Factor (dB/m)	Result (dBuV/m)	Limit (dBuV/m)	Margin (dB)	Remark
2390.000	44.95	-2.98	41.97	54.00	-12.03	AVG
2408.560	90.09	-2.92	87.17	-	-	AVG

Report No.: T180420W02-RP

Test Mode	IEEE 802.11g High CH	Temp/Hum	22(°C) / 34%RH
Test Item	Band Edge	Test Date	June 6, 2018
Polarize	Horizontal	Test Engineer	Jerry Chuang
Detector	Peak		

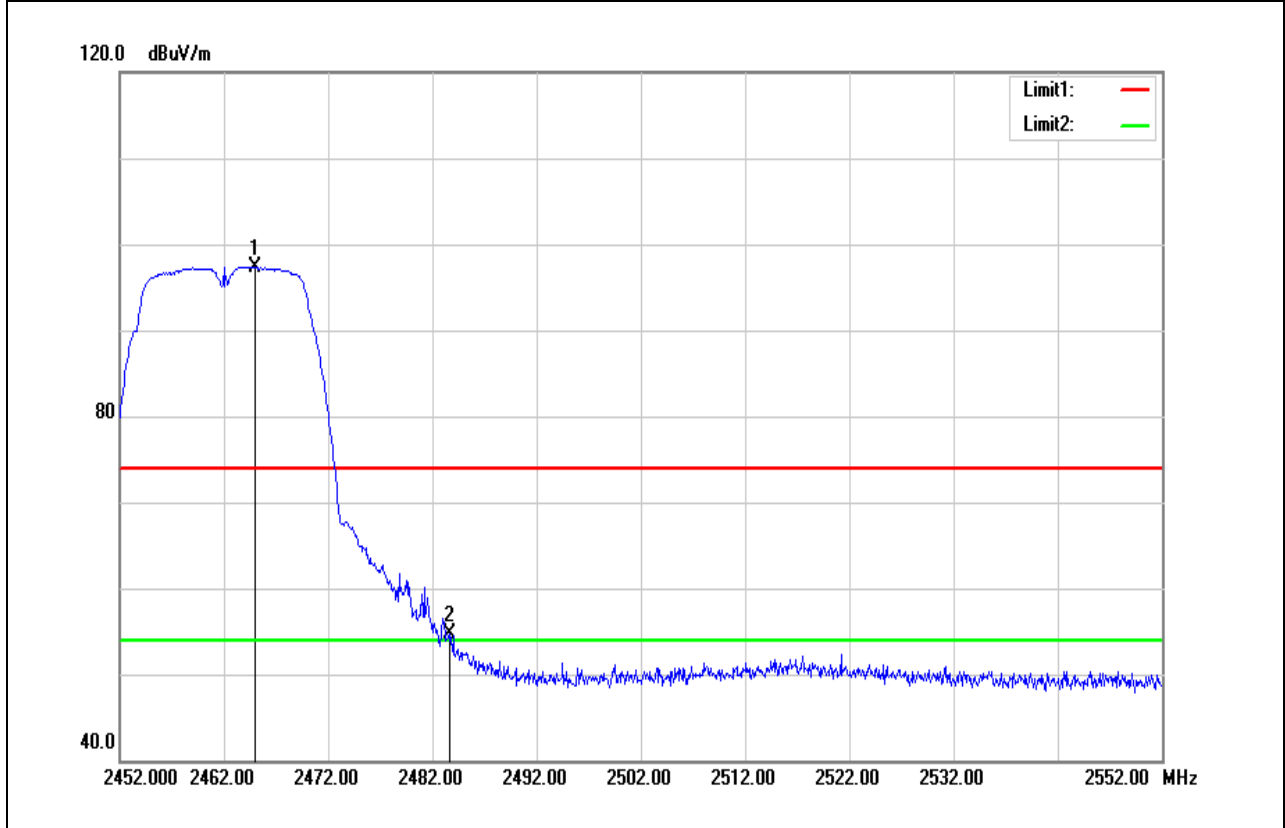

Frequency (MHz)	Reading (dBuV)	Correct Factor (dB/m)	Result (dBuV/m)	Limit (dBuV/m)	Margin (dB)	Remark
2465.000	100.14	-2.75	97.39	-	-	peak
2483.600	57.35	-2.69	54.66	74.00	-19.34	peak

**Report No.:** T180420W02-RP

Test Mode	IEEE 802.11g High CH	Temp/Hum	22(°C) / 34%RH
Test Item	Band Edge	Test Date	June 6, 2018
Polarize	Horizontal	Test Engineer	Jerry Chuang
Detector	Average		

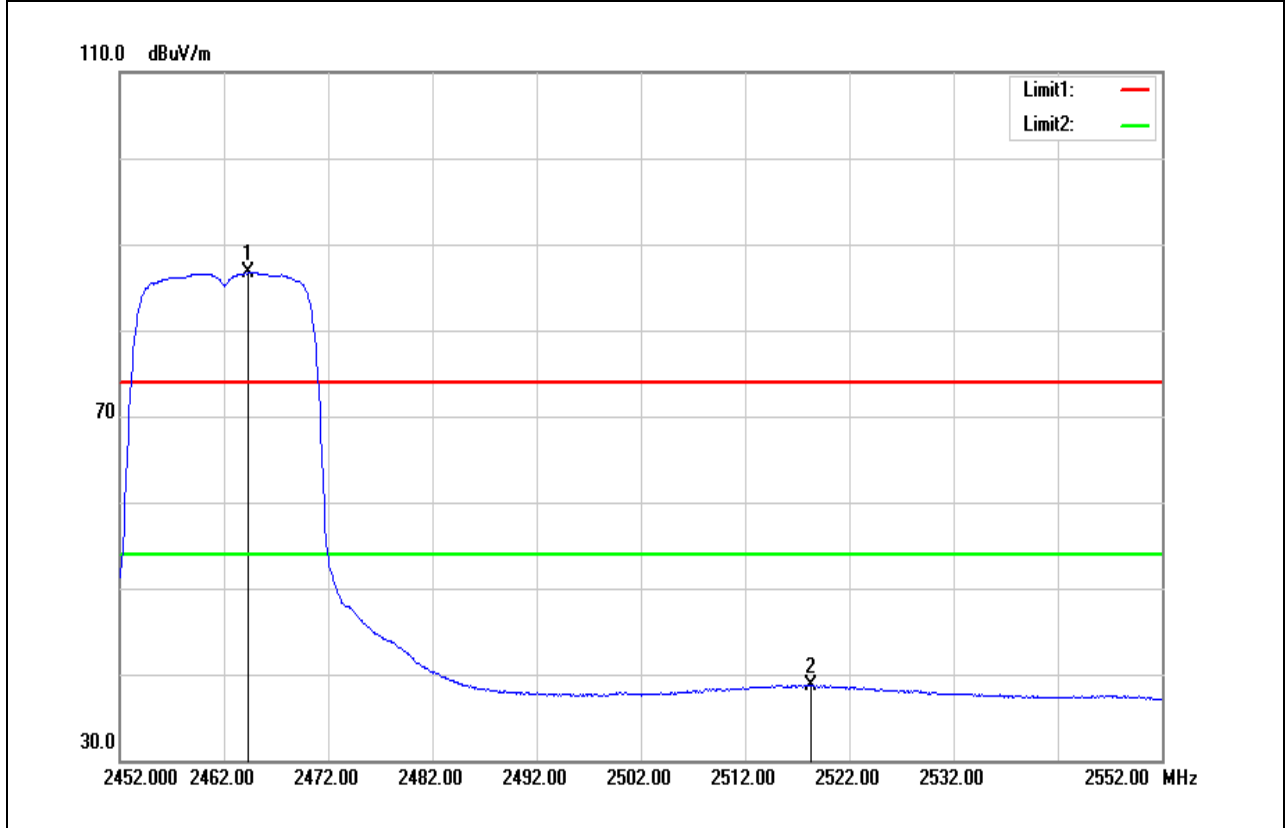

Frequency (MHz)	Reading (dBuV)	Correct Factor (dB/m)	Result (dBuV/m)	Limit (dBuV/m)	Margin (dB)	Remark
2464.300	89.52	-2.75	86.77	-	-	AVG
2518.300	41.32	-2.61	38.71	54.00	-15.29	AVG

Report No.: T180420W02-RP

Test Mode	IEEE 802.11n HT 20 Low CH	Temp/Hum	22(°C) / 34%RH
Test Item	Band Edge	Test Date	June 6, 2018
Polarize	Horizontal	Test Engineer	Jerry Chuang
Detector	Peak		

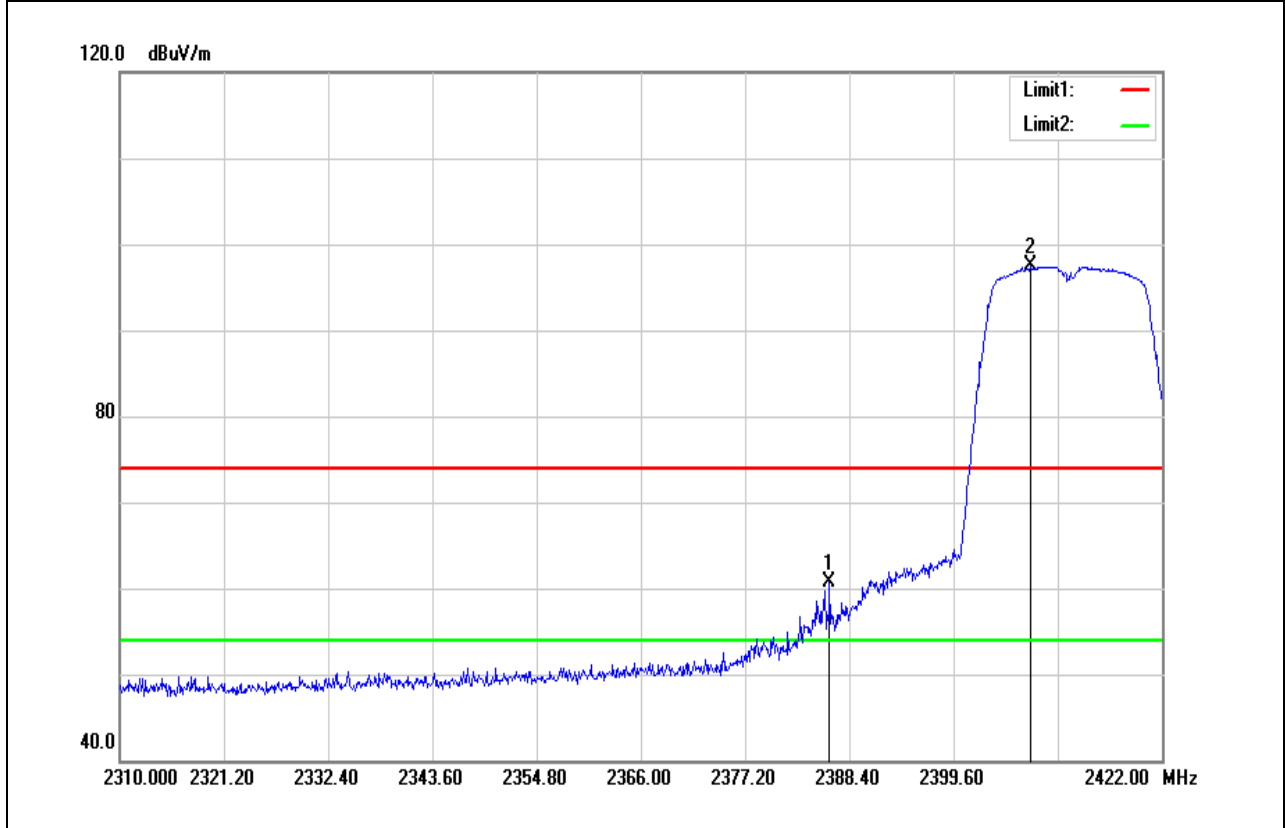

Frequency (MHz)	Reading (dBuV)	Correct Factor (dB/m)	Result (dBuV/m)	Limit (dBuV/m)	Margin (dB)	Remark
2386.272	63.60	-2.99	60.61	74.00	-13.39	peak
2407.888	100.39	-2.92	97.47	-	-	peak

Report No.: T180420W02-RP

Test Mode	IEEE 802.11n HT 20 Low CH	Temperature:	22(°C) / 34%RH
Test Item	Band Edge	Test Date	June 6, 2018
Polarize	Horizontal	Test Engineer	Jerry Chuang
Detector	Average		

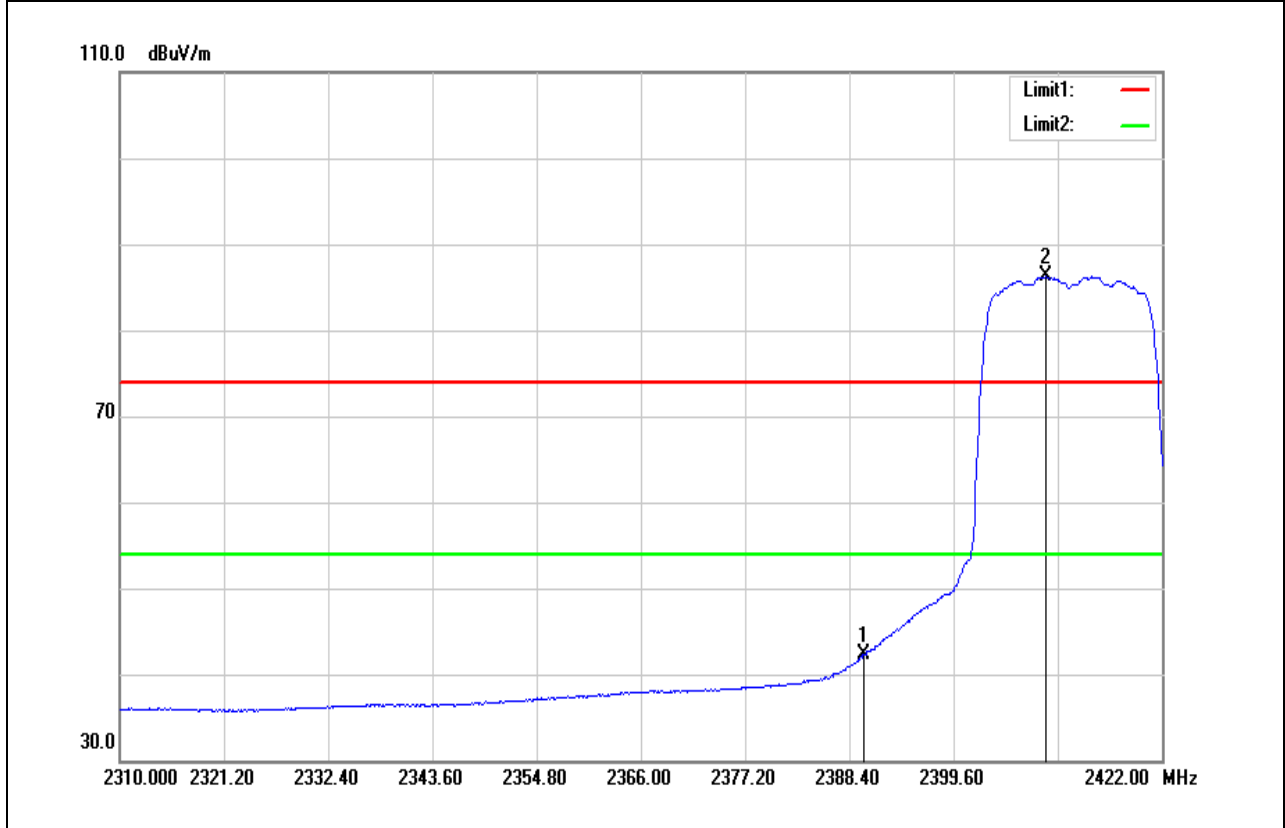

Frequency (MHz)	Reading (dBuV)	Correct Factor (dB/m)	Result (dBuV/m)	Limit (dBuV/m)	Margin (dB)	Remark
2390.000	45.31	-2.98	42.33	54.00	-11.67	AVG
2409.568	89.17	-2.92	86.25	-	-	AVG

**Report No.:** T180420W02-RP

Test Mode	IEEE 802.11n HT 20 High CH	Temp/Hum	22(°C) / 34%RH
Test Item	Band Edge	Test Date	June 6, 2018
Polarize	Horizontal	Test Engineer	Jerry Chuang
Detector	Peak		

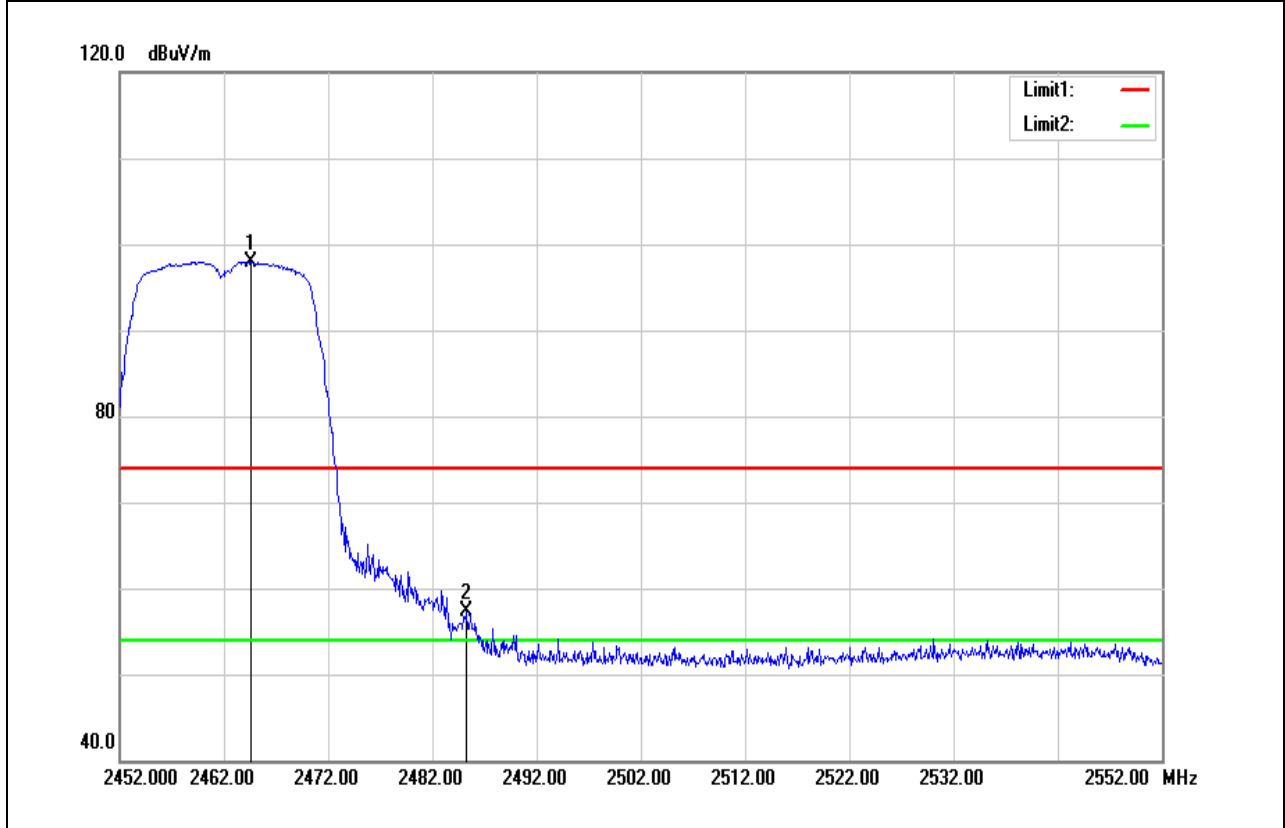

Frequency (MHz)	Reading (dBuV)	Correct Factor (dB/m)	Result (dBuV/m)	Limit (dBuV/m)	Margin (dB)	Remark
2464.600	100.75	-2.75	98.00	-	-	peak
2485.300	59.92	-2.69	57.23	74.00	-16.77	peak

**Report No.:** T180420W02-RP

Test Mode	IEEE 802.11n HT 20 High CH	Temperature:	22(°C) / 34%RH
Test Item	Band Edge	Test Date	June 6, 2018
Polarize	Horizontal	Test Engineer	Jerry Chuang
Detector	Average		

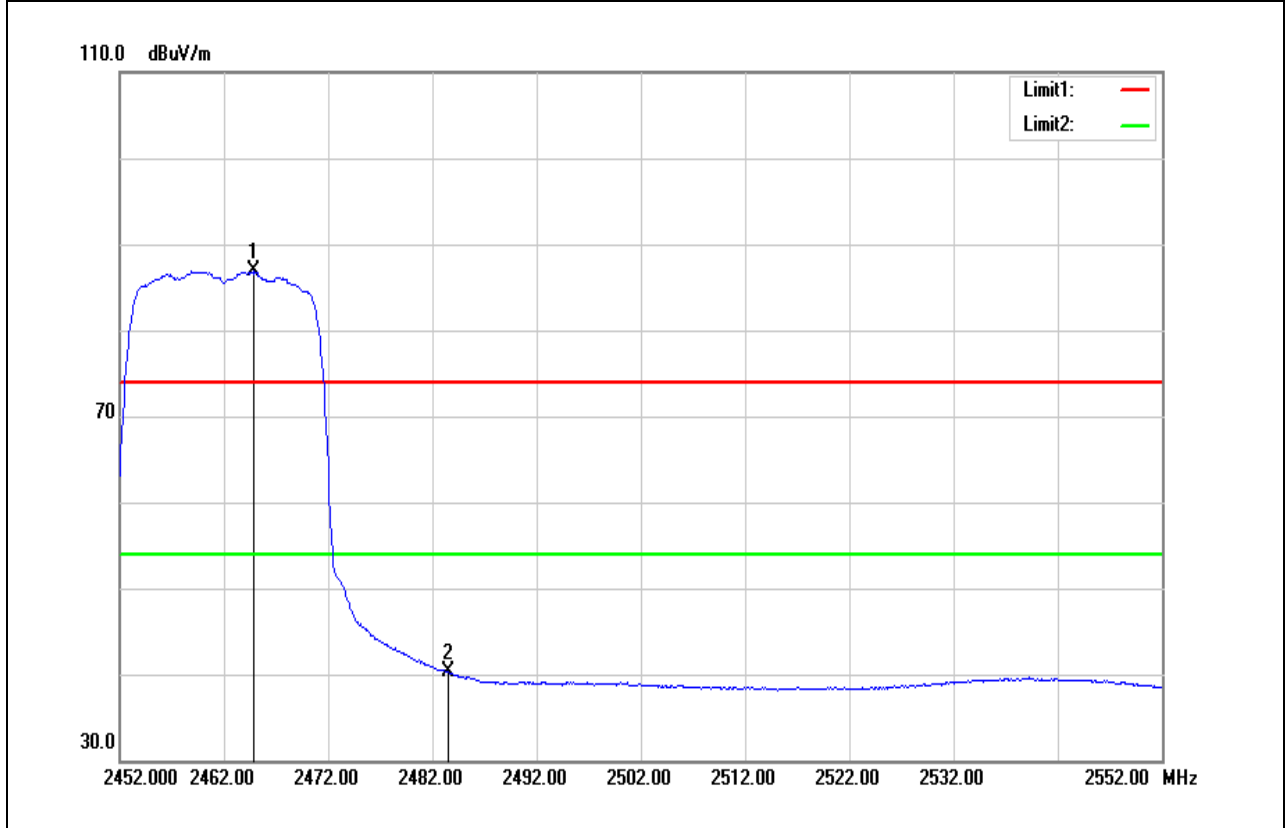

Frequency (MHz)	Reading (dBuV)	Correct Factor (dB/m)	Result (dBuV/m)	Limit (dBuV/m)	Margin (dB)	Remark
2464.800	89.56	-2.75	86.81	-	-	AVG
2483.500	42.90	-2.69	40.21	54.00	-13.79	AVG



**Report No.:** T180420W02-RP

**Below 1G Test Data**

Test Mode	Mode 1	Temp/Hum	22(°C) / 34%RH
Test Item	30MHz-1GHz	Test Date	June 6, 2018
Polarize	Vertical	Test Engineer	Jerry Chuang
Detector	Peak		

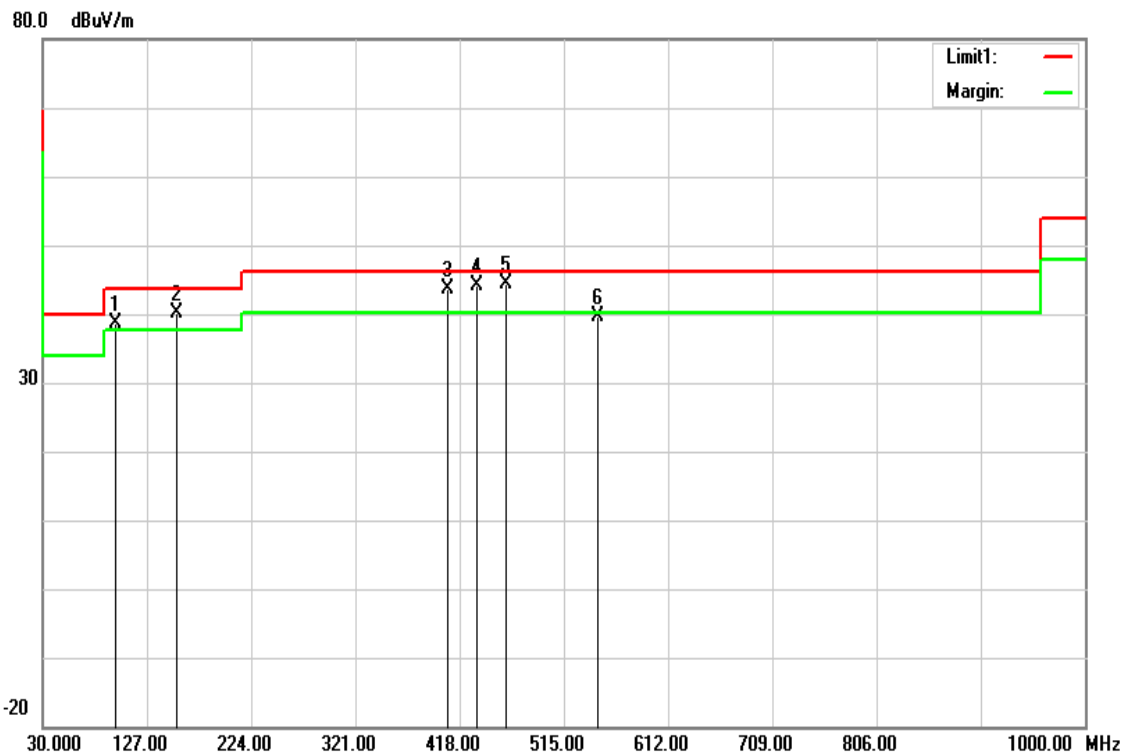

Frequency (MHz)	Reading (dBuV)	Correct Factor (dB/m)	Result (dBuV/m)	Limit (dBuV/m)	Margin (dB)	Remark
97.9000	57.68	-19.13	38.55	43.52	-4.97	QP
154.1600	56.08	-15.83	40.25	43.52	-3.27	QP
406.3600	54.77	-11.16	43.61	46.02	-2.41	QP
433.5200	54.24	-10.19	44.05	46.02	-1.97	QP
461.6500	53.61	-9.34	44.27	46.02	-1.75	QP
546.0400	47.37	-7.63	39.74	46.02	-6.28	QP

**Report No.:** T180420W02-RP

Test Mode	Mode 1	Temp/Hum	22(°C) / 34%RH
Test Item	30MHz-1GHz	Test Date	June 6, 2018
Polarize	Horizontal	Test Engineer	Jerry Chuang
Detector	Peak		

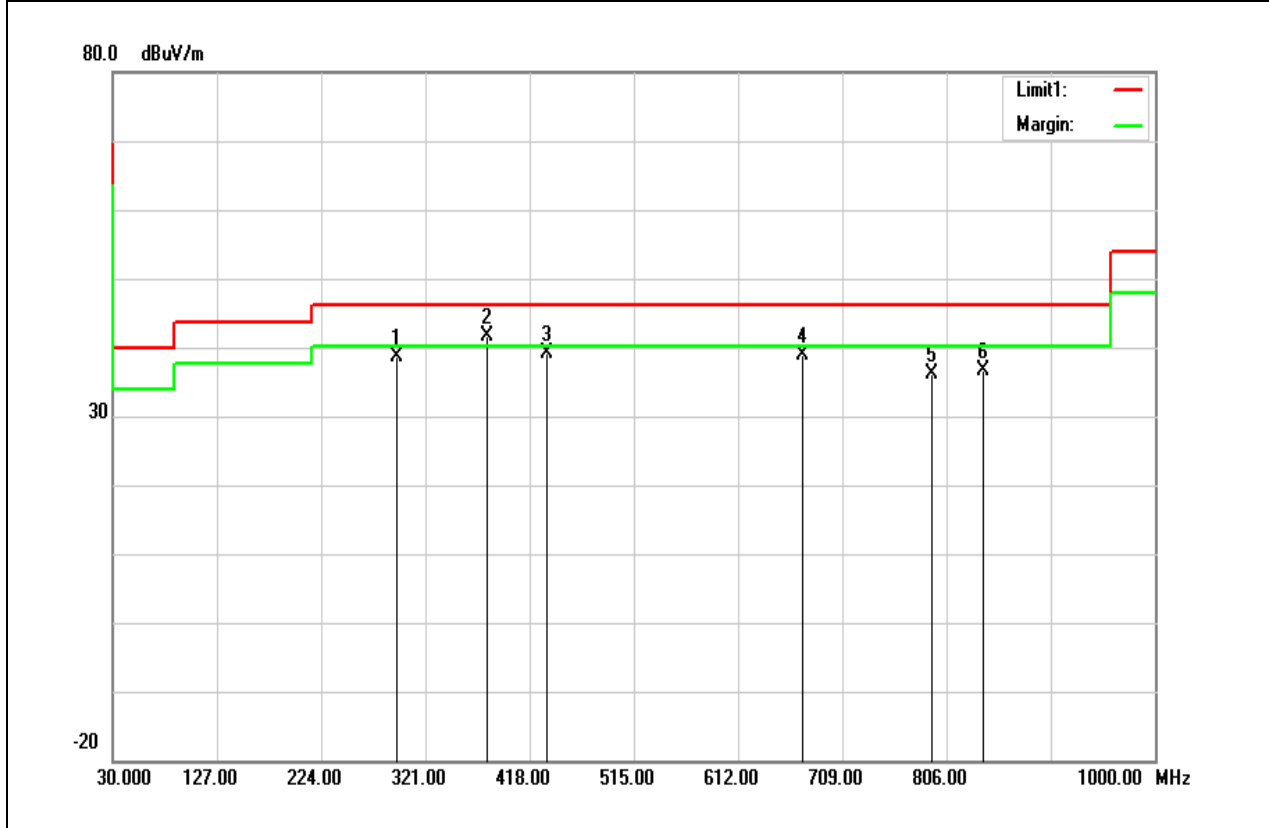

Frequency (MHz)	Reading (dBuV)	Correct Factor (dB/m)	Result (dBuV/m)	Limit (dBuV/m)	Margin (dB)	Remark
293.8400	52.71	-14.13	38.58	46.02	-7.44	QP
378.2300	53.66	-12.08	41.58	46.02	-4.44	QP
433.5200	49.42	-10.19	39.23	46.02	-6.79	peak
672.1400	44.17	-5.26	38.91	46.02	-7.11	peak
792.4200	39.57	-3.51	36.06	46.02	-9.96	peak
839.9500	39.58	-2.96	36.62	46.02	-9.40	peak

**Report No.:** T180420W02-RP  
**Above 1G Test Data**

Test Mode	IEEE 802.11b Low CH	Temp/Hum	22(°C) / 34%RH
Test Item	Harmonic	Test Date	June 6, 2018
Polarize	Vertical	Test Engineer	Jerry Chuang
Detector	Peak and Average		

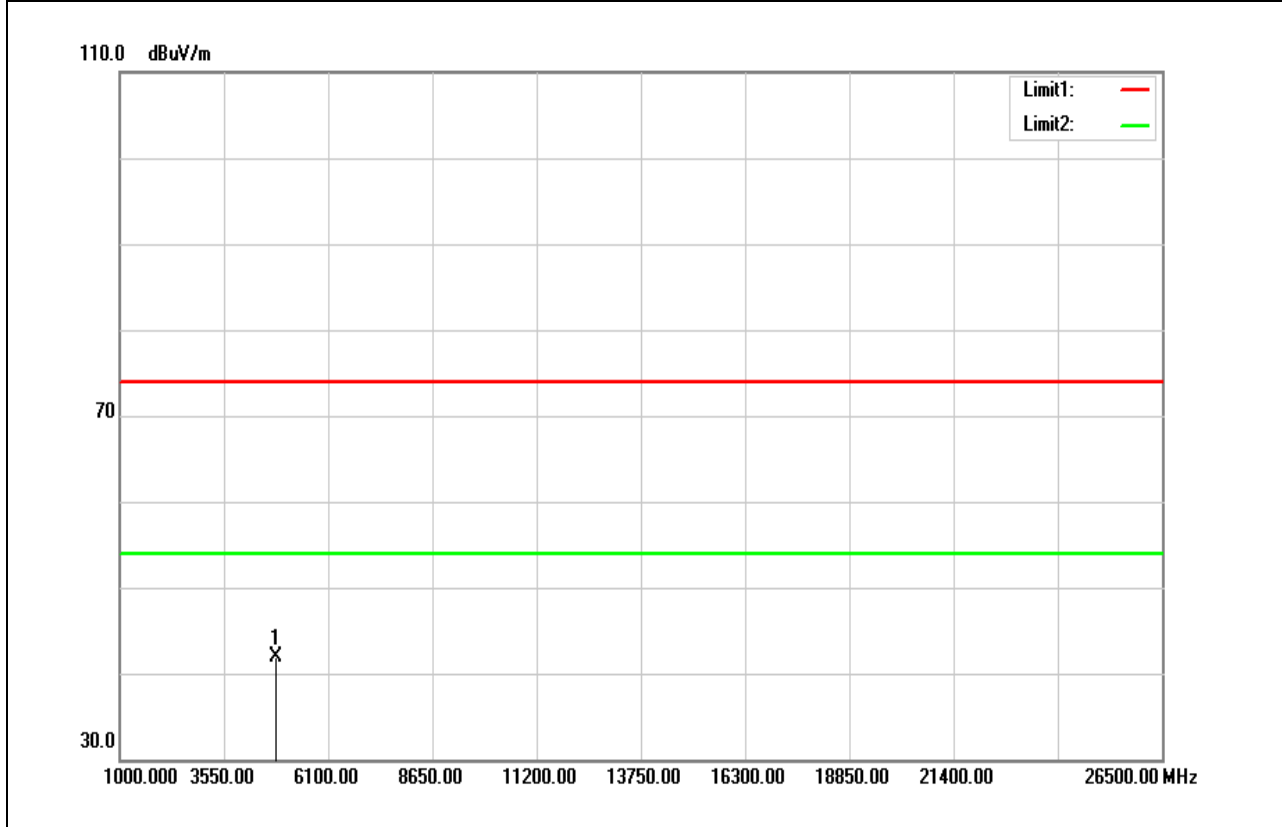

Frequency (MHz)	Reading (dBuV)	Correct Factor (dB/m)	Result (dBuV/m)	Limit (dBuV/m)	Margin (dB)	Remark
4824.000	37.49	4.38	41.87	74.00	-32.13	peak
N/A						

**Remark:**

1. Measuring frequencies from 1 GHz to the 10th harmonic of highest fundamental frequency.
2. For above 1GHz, the EUT peak value was under average limit, therefore the Average value compliance with the average limit

Report No.: T180420W02-RP

Test Mode	IEEE 802.11b Low CH	Temp/Hum	22(°C) / 34%RH
Test Item	Harmonic	Test Date	June 6, 2018
Polarize	Horizontal	Test Engineer	Jerry Chuang
Detector	Peak and Average		

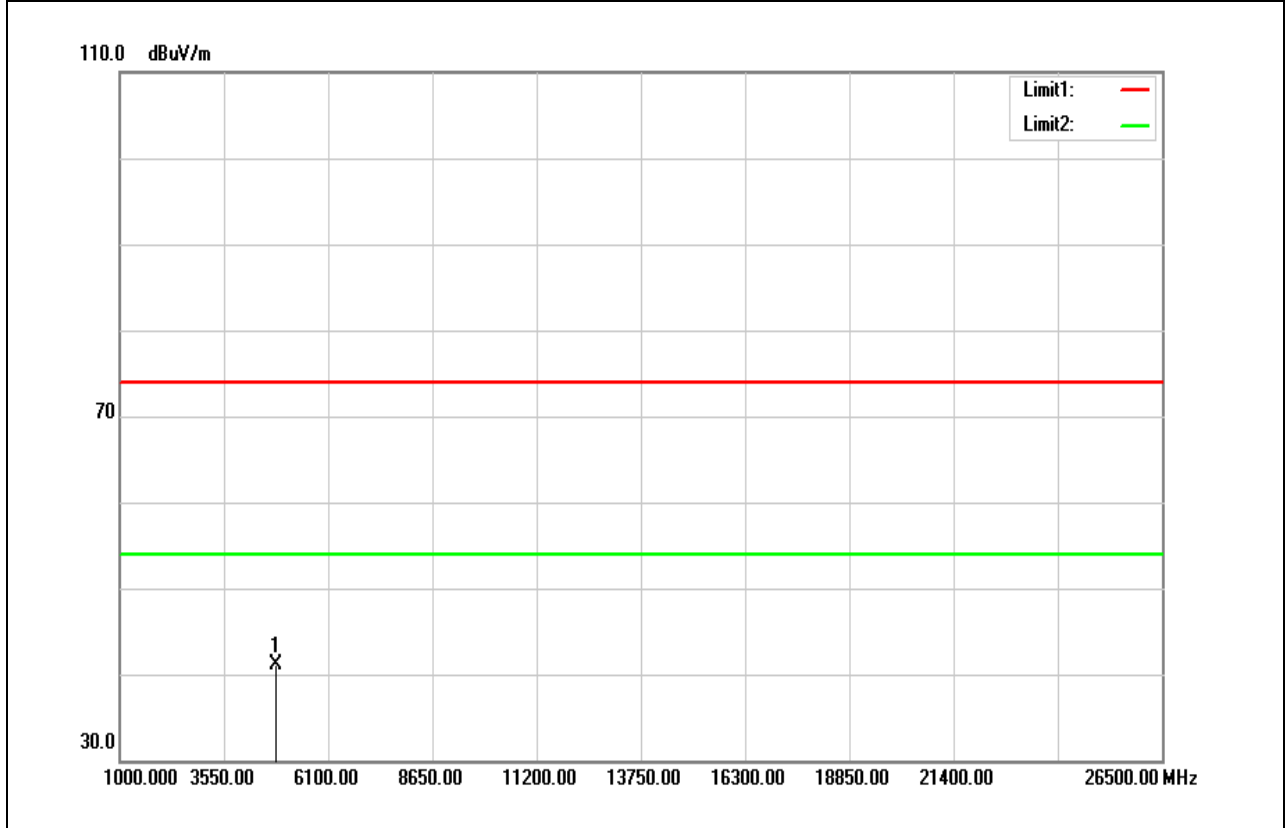

Frequency (MHz)	Reading (dBuV)	Correct Factor (dB/m)	Result (dBuV/m)	Limit (dBuV/m)	Margin (dB)	Remark
4824.000	36.73	4.38	41.11	74.00	-32.89	peak
N/A						

**Remark:**

1. Measuring frequencies from 1 GHz to the 10th harmonic of highest fundamental frequency.
2. For above 1GHz, the EUT peak value was under average limit, therefore the Average value compliance with the average limit

Test Mode	IEEE 802.11b Mid CH	Temp/Hum	22(°C) / 34%RH
Test Item	Harmonic	Test Date	June 6, 2018
Polarize	Vertical	Test Engineer	Jerry Chuang
Detector	Peak and Average		

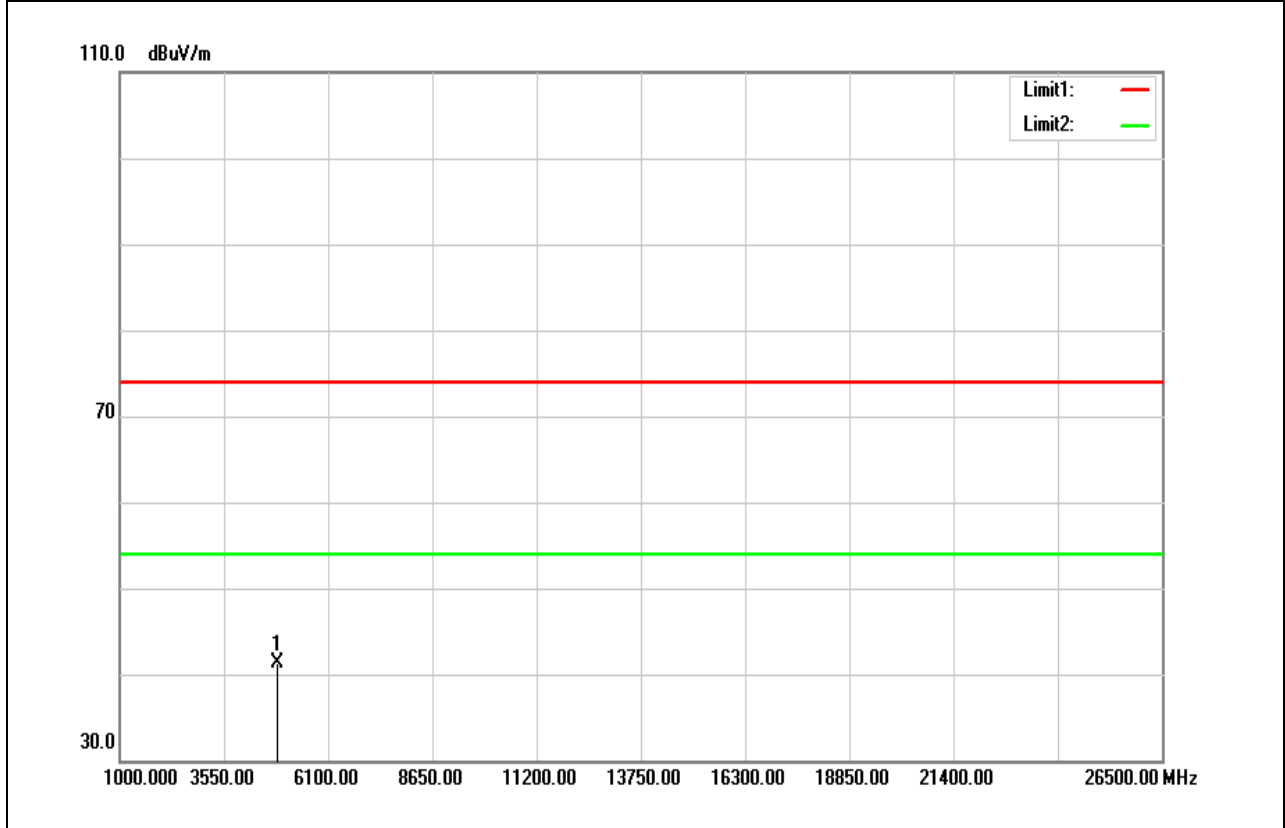

Frequency (MHz)	Reading (dBu )	Correct Factor (dB/m)	Result (dBuV/m)	Limit (dBuV/m)	Margin (dB)	Remark
4874.000	36.91	4.47	41.38	74.00	-32.62	peak
N/A						

**Remark:**

1. Measuring frequencies from 1 GHz to the 10th harmonic of highest fundamental frequency.
2. For above 1GHz, the EUT peak value was under average limit, therefore the Average value compliance with the average limit

Report No.: T180420W02-RP

Test Mode	IEEE 802.11b Mid CH	Temp/Hum	22(°C) / 34%RH
Test Item	Harmonic	Test Date	June 6, 2018
Polarize	Horizontal	Test Engineer	Jerry Chuang
Detector	Peak and Average		

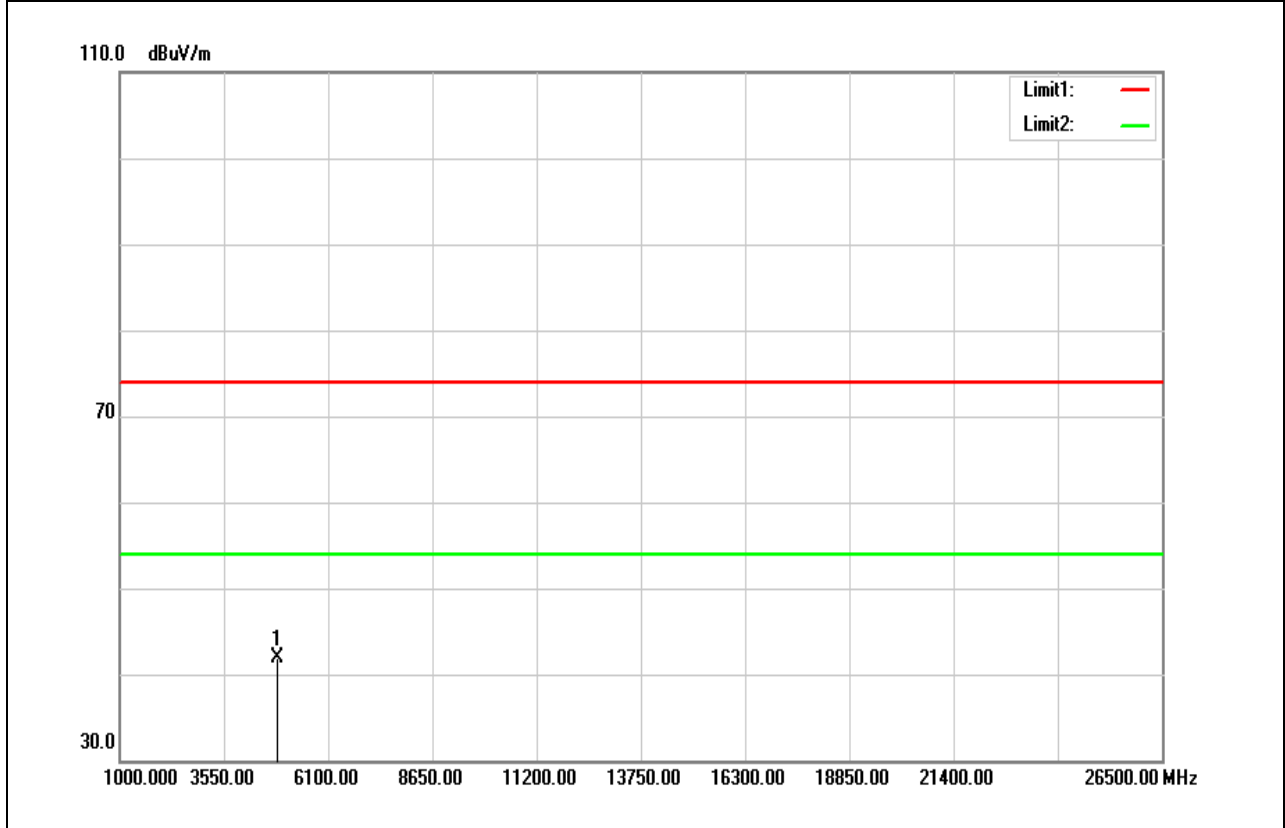

Frequency (MHz)	Reading (dBuV)	Correct Factor (dB/m)	Result (dBuV/m)	Limit (dBuV/m)	Margin (dB)	Remark
4874.000	37.38	4.47	41.85	74.00	-32.15	peak
N/A						

**Remark:**

1. Measuring frequencies from 1 GHz to the 10th harmonic of highest fundamental frequency.
2. For above 1GHz, the EUT peak value was under average limit, therefore the Average value compliance with the average limit

Report No.: T180420W02-RP

Test Mode	IEEE 802.11b High CH	Temp/Hum	22(°C) / 34%RH
Test Item	Harmonic	Test Date	June 6, 2018
Polarize	Vertical	Test Engineer	Jerry Chuang
Detector	Peak and Average		

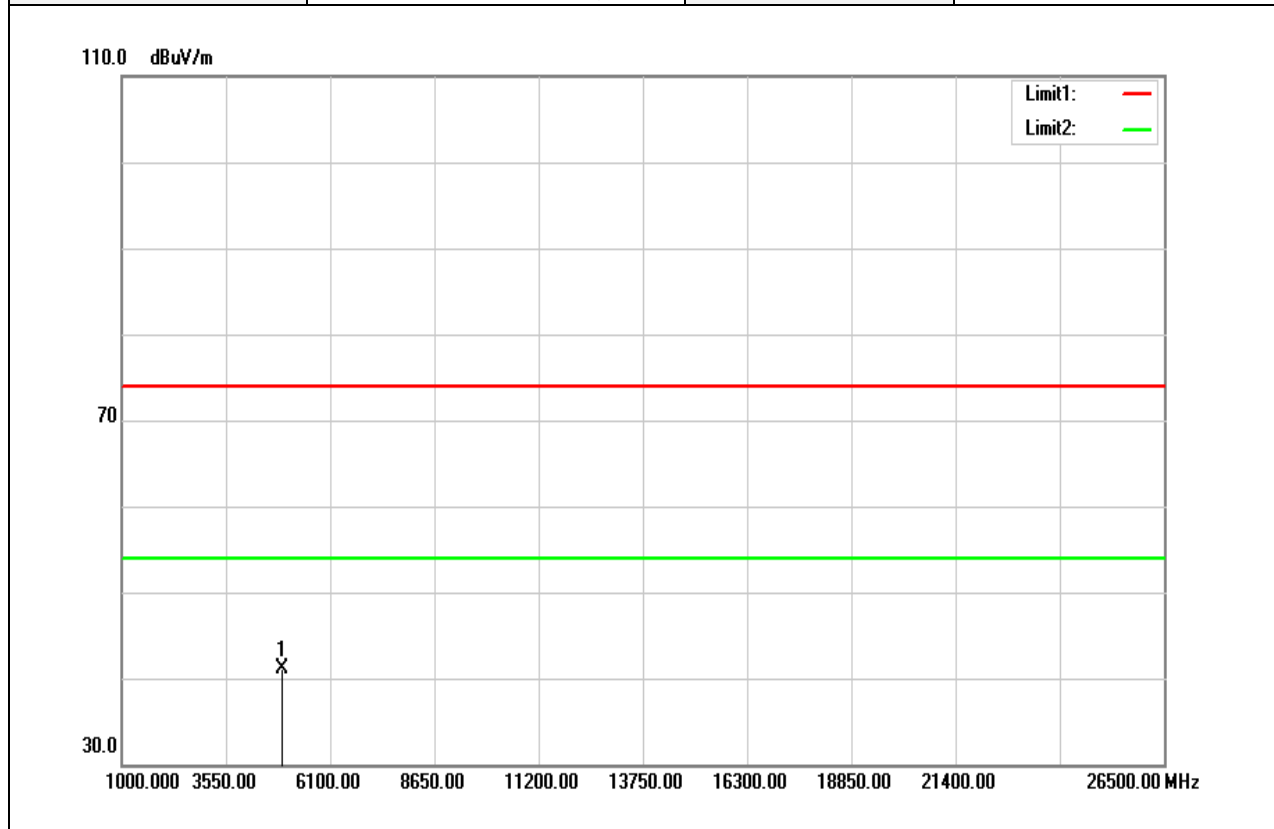

Frequency (MHz)	Reading (dBuV)	Correct Factor (dB/m)	Result (dBuV/m)	Limit (dBuV/m)	Margin (dB)	Remark
4924.000	36.54	4.55	41.09	74.00	-32.91	peak
N/A						

**Remark:**

1. Measuring frequencies from 1 GHz to the 10th harmonic of highest fundamental frequency.
2. For above 1GHz, the EUT peak value was under average limit, therefore the Average value compliance with the average limit

Test Mode	IEEE 802.11b High CH	Temp/Hum	22(°C) / 34%RH
Test Item	Harmonic	Test Date	June 6, 2018
Polarize	Horizontal	Test Engineer	Jerry Chuang
Detector	Peak and Average		

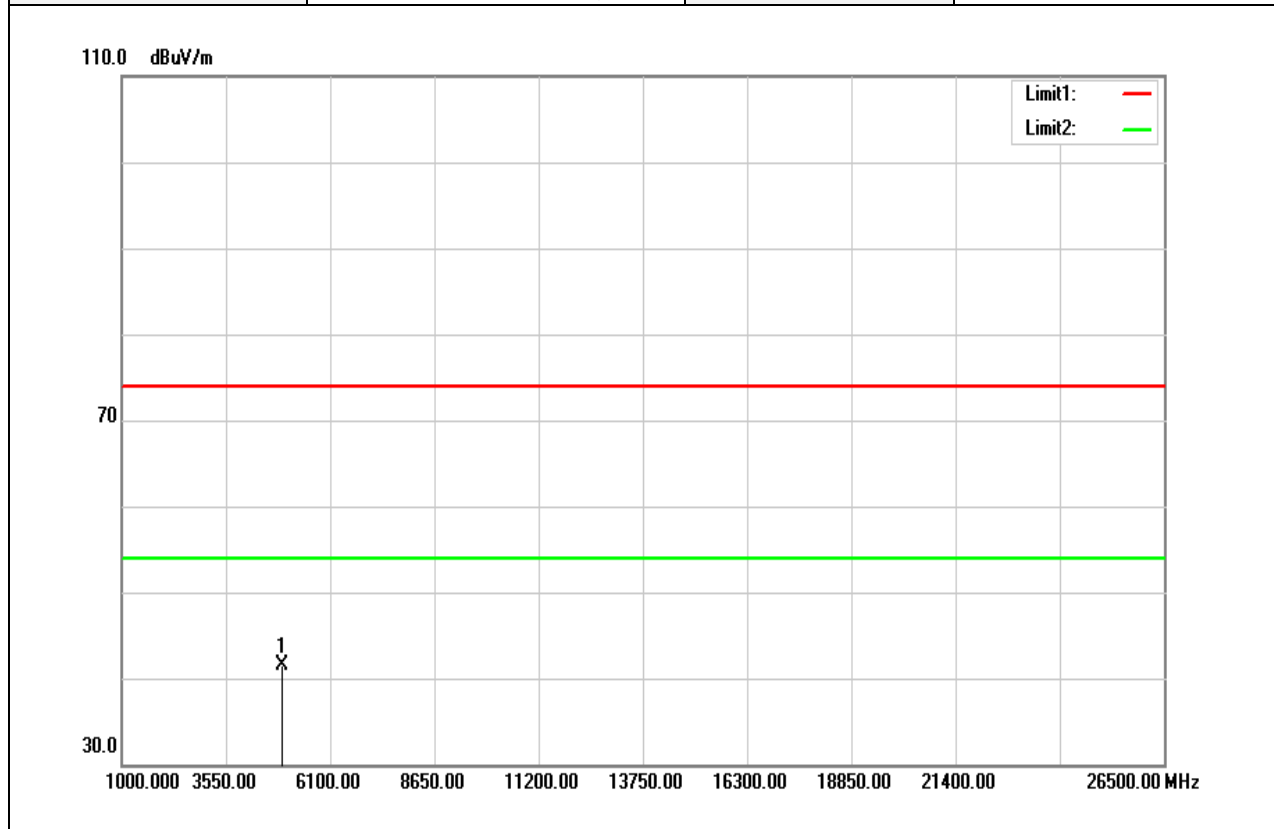

Frequency (MHz)	Reading (dBuV)	Correct Factor (dB/m)	Result (dBuV/m)	Limit (dBuV/m)	Margin (dB)	Remark
4924.000	36.92	4.55	41.47	74.00	-32.53	peak
N/A						

**Remark:**

1. Measuring frequencies from 1 GHz to the 10th harmonic of highest fundamental frequency.
2. For above 1GHz, the EUT peak value was under average limit, therefore the Average value compliance with the average limit



Report No.: T180420W02-RP

Test Mode	IEEE 802.11g Low CH	Temp/Hum	22(°C) / 34%RH
Test Item	Harmonic	Test Date	June 6, 2018
Polarize	Vertical	Test Engineer	Jerry Chuang
Detector	Peak and Average		

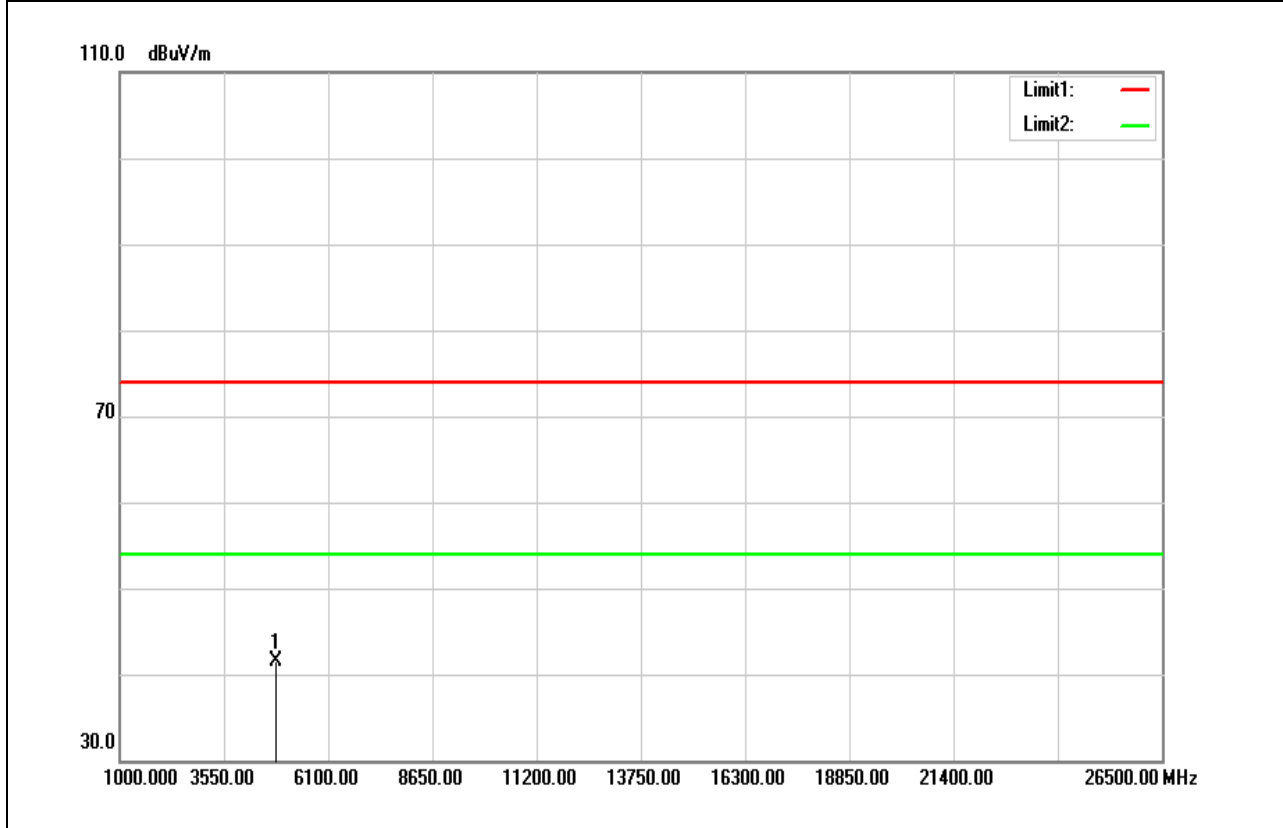

Frequency (MHz)	Reading (dBuV)	Correct Factor (dB/m)	Result (dBuV/m)	Limit (dBuV/m)	Margin (dB)	Remark
4824.000	37.18	4.38	41.56	74.00	-32.44	peak
N/A						

**Remark:**

1. Measuring frequencies from 1 GHz to the 10th harmonic of highest fundamental frequency.
2. For above 1GHz, the EUT peak value was under average limit, therefore the Average value compliance with the average limit

Report No.: T180420W02-RP

Test Mode	IEEE 802.11g Low CH	Temp/Hum	22(°C) / 34%RH
Test Item	Harmonic	Test Date	June 6, 2018
Polarize	Horizontal	Test Engineer	Jerry Chuang
Detector	Peak and Average		

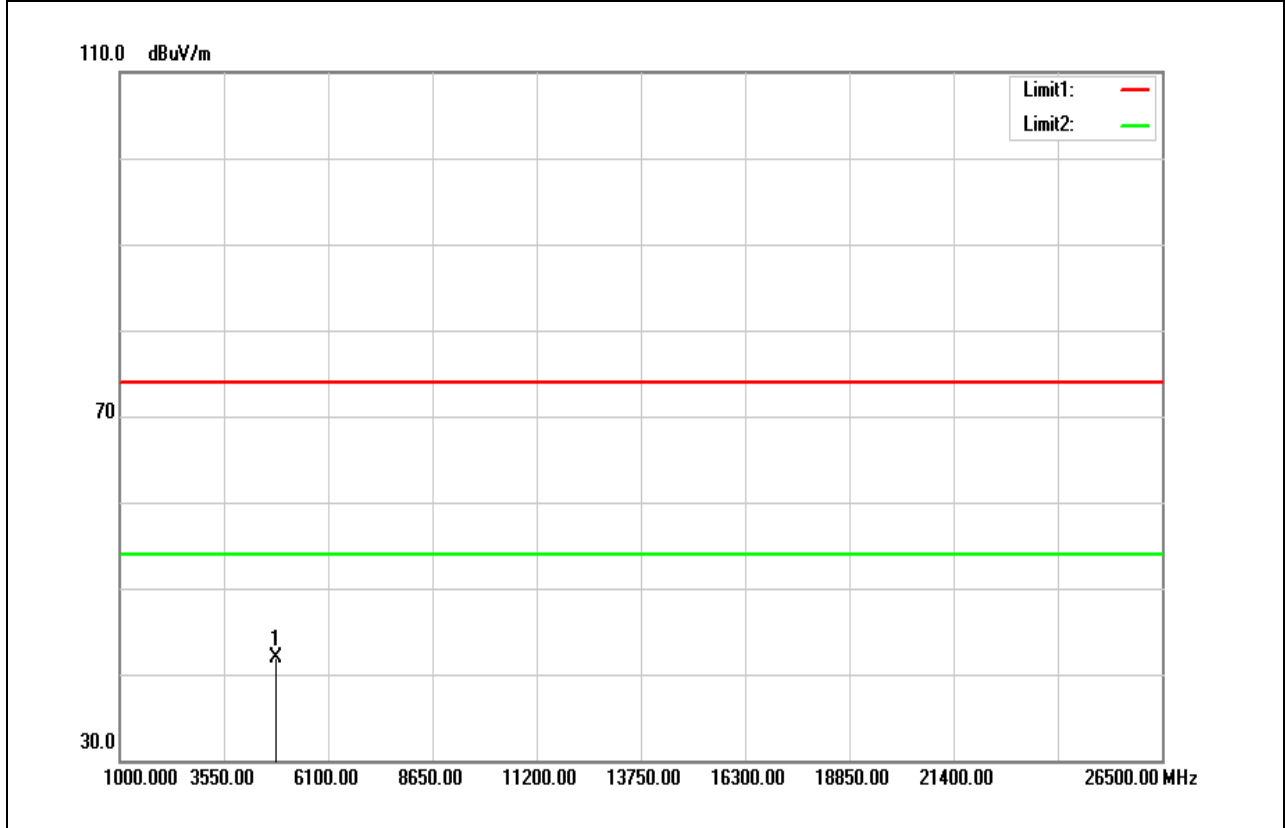

Frequency (MHz)	Reading (dBuV)	Correct Factor (dB/m)	Result (dBuV/m)	Limit (dBuV/m)	Margin (dB)	Remark
4824.000	37.56	4.38	41.94	74.00	-32.06	peak
N/A						

**Remark:**

1. Measuring frequencies from 1 GHz to the 10th harmonic of highest fundamental frequency.
2. For above 1GHz, the EUT peak value was under average limit, therefore the Average value compliance with the average limit

Report No.: T180420W02-RP

Test Mode	IEEE 802.11g Mid CH	Temp/Hum	22(°C) / 34%RH
Test Item	Harmonic	Test Date	June 6, 2018
Polarize	Vertical	Test Engineer	Jerry Chuang
Detector	Peak and Average		

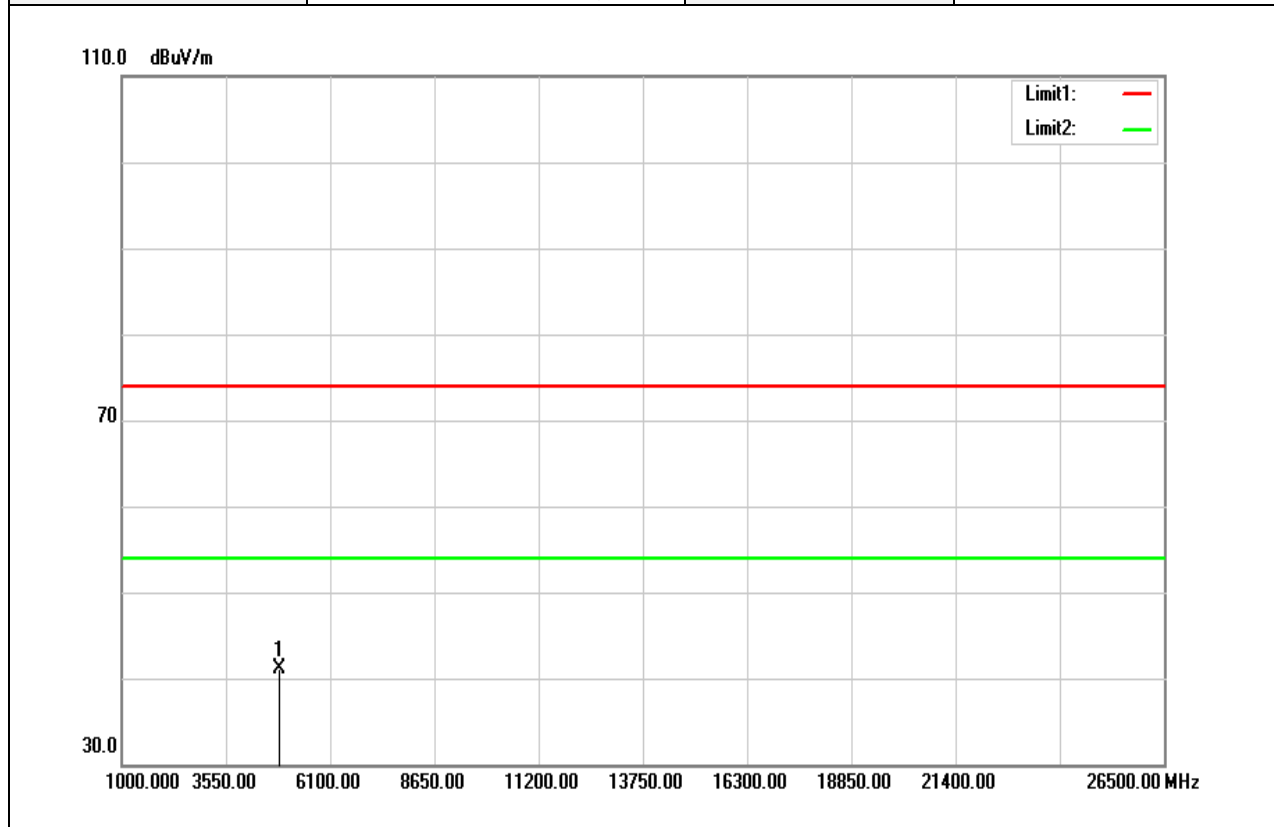

Frequency (MHz)	Reading (dBuV)	Correct Factor (dB/m)	Result (dBuV/m)	Limit (dBuV/m)	Margin (dB)	Remark
4874.000	36.64	4.47	41.11	74.00	-32.89	peak
N/A						

**Remark:**

1. Measuring frequencies from 1 GHz to the 10th harmonic of highest fundamental frequency.
2. For above 1GHz, the EUT peak value was under average limit, therefore the Average value compliance with the average limit

Test Mode	IEEE 802.11g Mid CH	Temp/Hum	22(°C) / 34%RH
Test Item	Harmonic	Test Date	June 6, 2018
Polarize	Horizontal	Test Engineer	Jerry Chuang
Detector	Peak and Average		

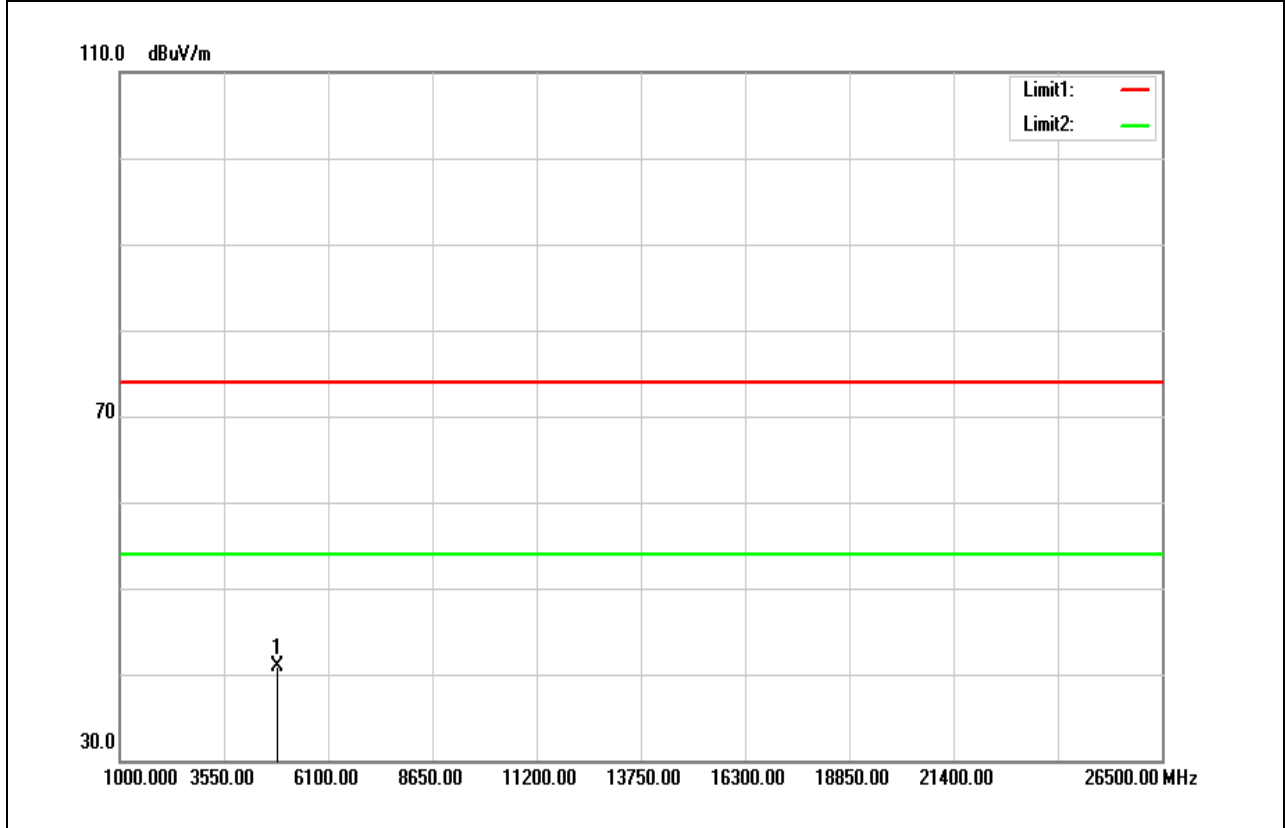

Frequency (MHz)	Reading (dBuV)	Correct Factor (dB/m)	Result (dBuV/m)	Limit (dBuV/m)	Margin (dB)	Remark
4874.000	36.44	4.47	40.91	74.00	-33.09	peak
N/A						

**Remark:**

1. Measuring frequencies from 1 GHz to the 10th harmonic of highest fundamental frequency.
2. For above 1GHz, the EUT peak value was under average limit, therefore the Average value compliance with the average limit

Test Mode	IEEE 802.11g High CH	Temp/Hum	22(°C) / 34%RH
Test Item	Harmonic	Test Date	June 6, 2018
Polarize	Vertical	Test Engineer	Jerry Chuang
Detector	Peak and Average		

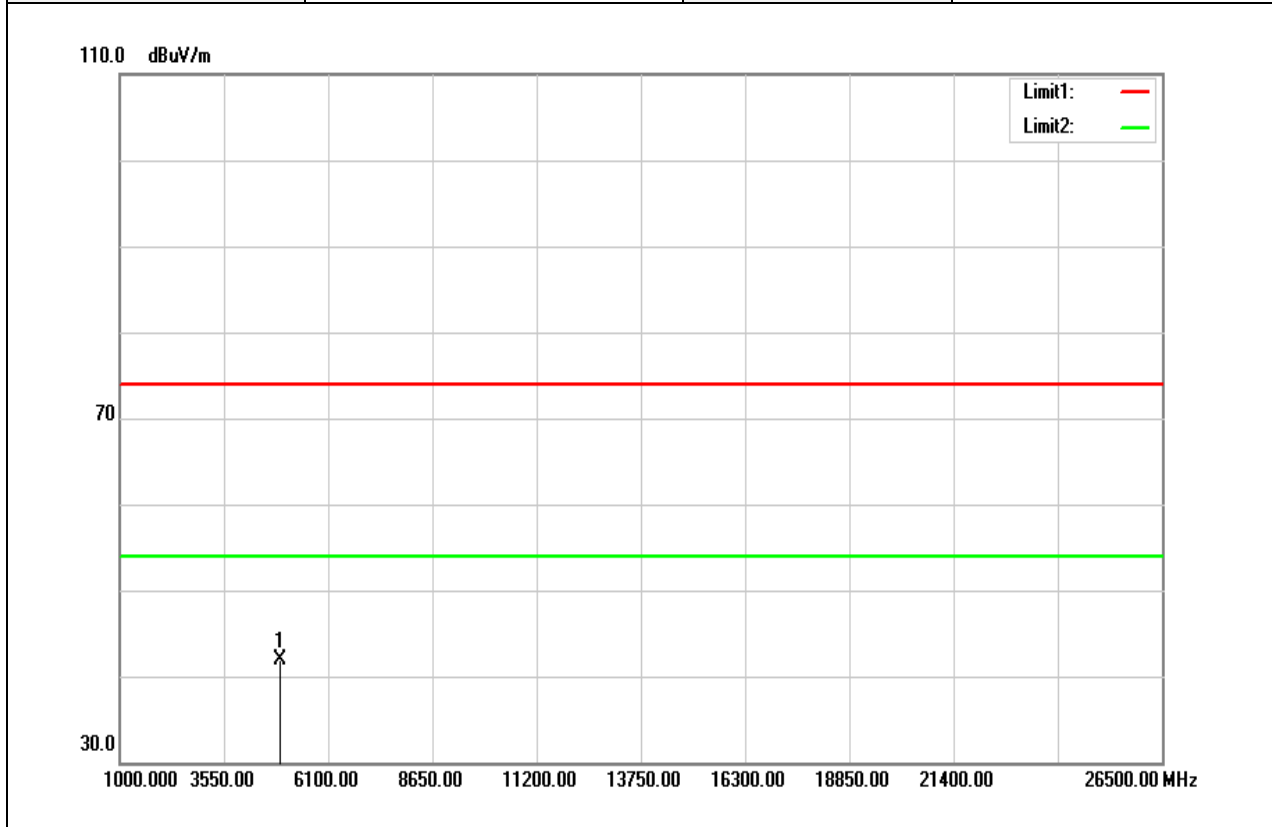

Frequency (MHz)	Reading (dBuV)	Correct Factor (dB/m)	Result (dBuV/m)	Limit (dBuV/m)	Margin (dB)	Remark
4924.000	37.33	4.55	41.88	74.00	-32.12	peak
N/A						

**Remark:**

1. Measuring frequencies from 1 GHz to the 10th harmonic of highest fundamental frequency.
2. For above 1GHz, the EUT peak value was under average limit, therefore the Average value compliance with the average limit

Report No.: T180420W02-RP

Test Mode	IEEE 802.11g High CH	Temp/Hum	22(°C) / 34%RH
Test Item	Harmonic	Test Date	June 6, 2018
Polarize	Horizontal	Test Engineer	Jerry Chuang
Detector	Peak and Average		

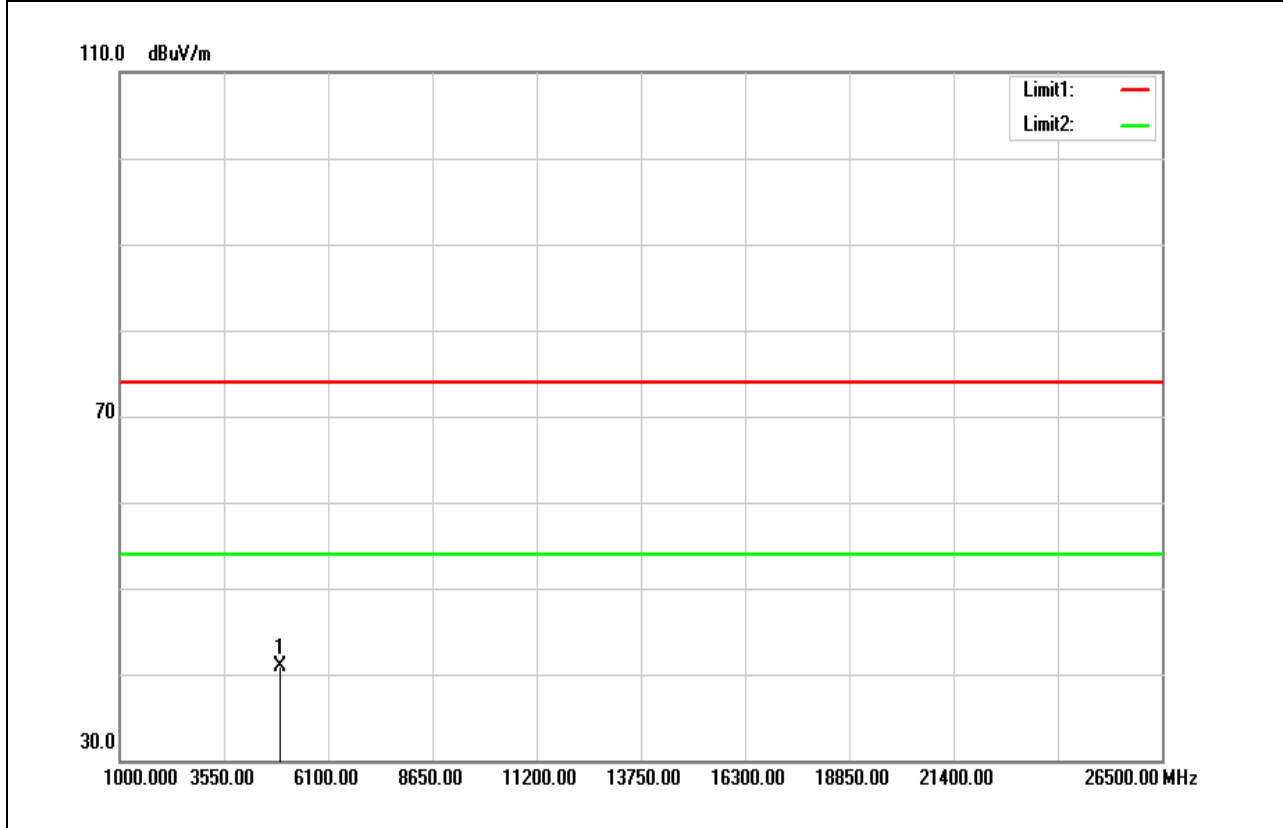

Frequency (MHz)	Reading (dBuV)	Correct Factor (dB/m)	Result (dBuV/m)	Limit (dBuV/m)	Margin (dB)	Remark
4924.000	36.31	4.55	40.86	74.00	-33.14	peak
N/A						

**Remark:**

1. Measuring frequencies from 1 GHz to the 10th harmonic of highest fundamental frequency.
2. For above 1GHz, the EUT peak value was under average limit, therefore the Average value compliance with the average limit

Report No.: T180420W02-RP

Test Mode	IEEE 802.11n HT 20 Low CH	Temp/Hum	22(°C) / 34%RH
Test Item	Harmonic	Test Date	June 6, 2018
Polarize	Vertical	Test Engineer	Jerry Chuang
Detector	Peak and Average		

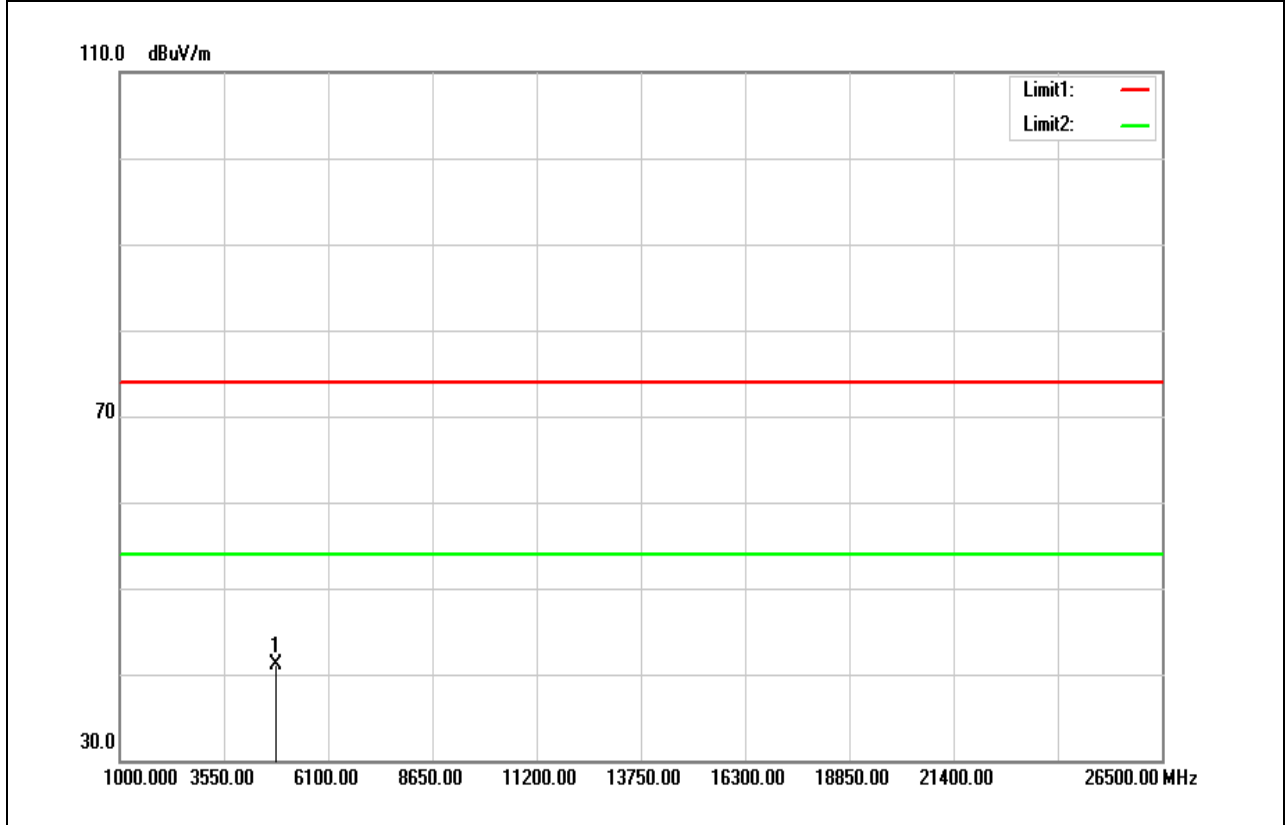

Frequency (MHz)	Reading (dBuV)	Correct Factor (dB/m)	Result (dBuV/m)	Limit (dBuV/m)	Margin (dB)	Remark
4824.000	36.80	4.38	41.18	74.00	-32.82	peak
N/A						

**Remark:**

- Measuring frequencies from 1 GHz to the 10th harmonic of highest fundamental frequency.
- For above 1GHz, the EUT peak value was under average limit, therefore the Average value compliance with the average limit

Report No.: T180420W02-RP

Test Mode	IEEE 802.11n HT 20 Low CH	Temp/Hum	22(°C) / 34%RH
Test Item	Harmonic	Test Date	June 6, 2018
Polarize	Horizontal	Test Engineer	Jerry Chuang
Detector	Peak and Average		

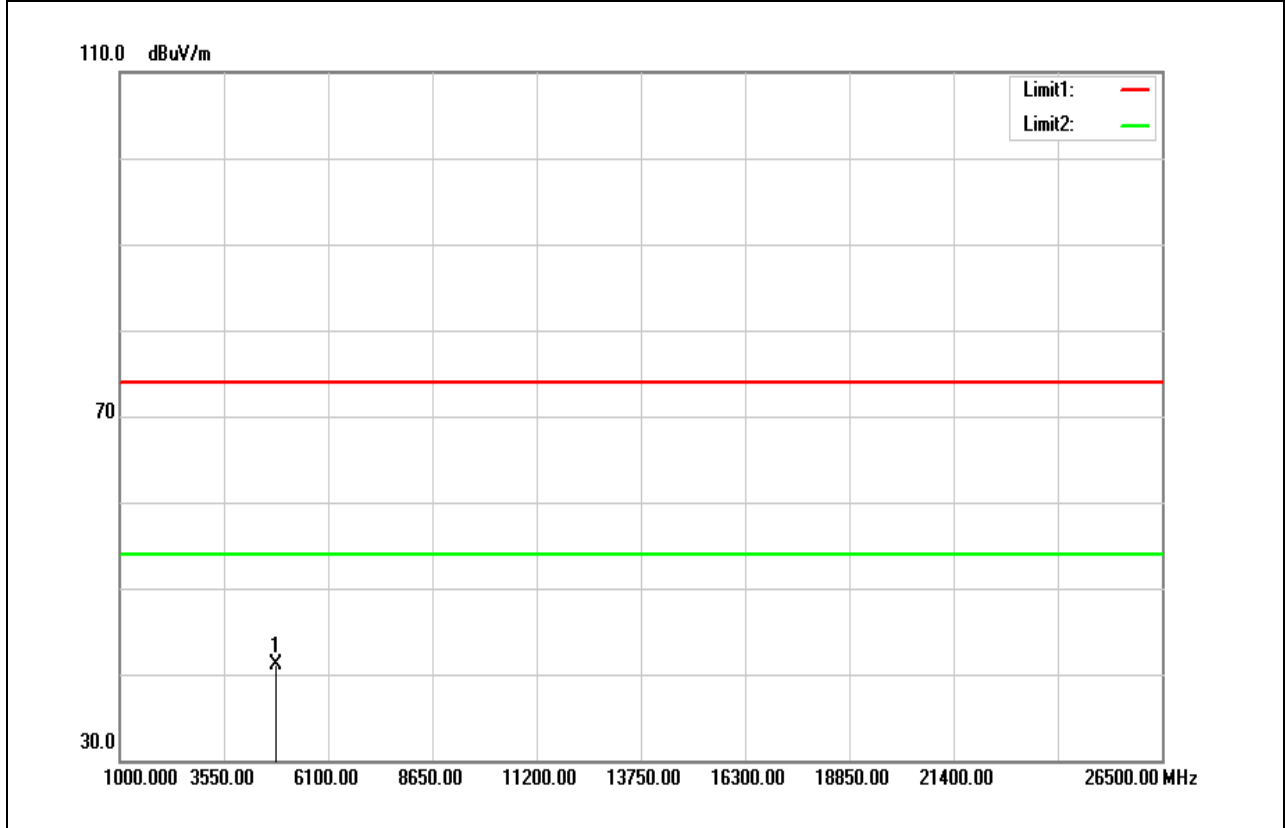

Frequency (MHz)	Reading (dBuV)	Correct Factor (dB/m)	Result (dBuV/m)	Limit (dBuV/m)	Margin (dB)	Remark
4824.000	36.71	4.38	41.09	74.00	-32.91	peak
N/A						

**Remark:**

1. Measuring frequencies from 1 GHz to the 10th harmonic of highest fundamental frequency.
2. For above 1GHz, the EUT peak value was under average limit, therefore the Average value compliance with the average limit



Report No.: T180420W02-RP

Test Mode	IEEE 802.11n HT 20 Mid CH	Temp/Hum	22(°C) / 34%RH
Test Item	Harmonic	Test Date	June 6, 2018
Polarize	Vertical	Test Engineer	Jerry Chuang
Detector	Peak and Average		

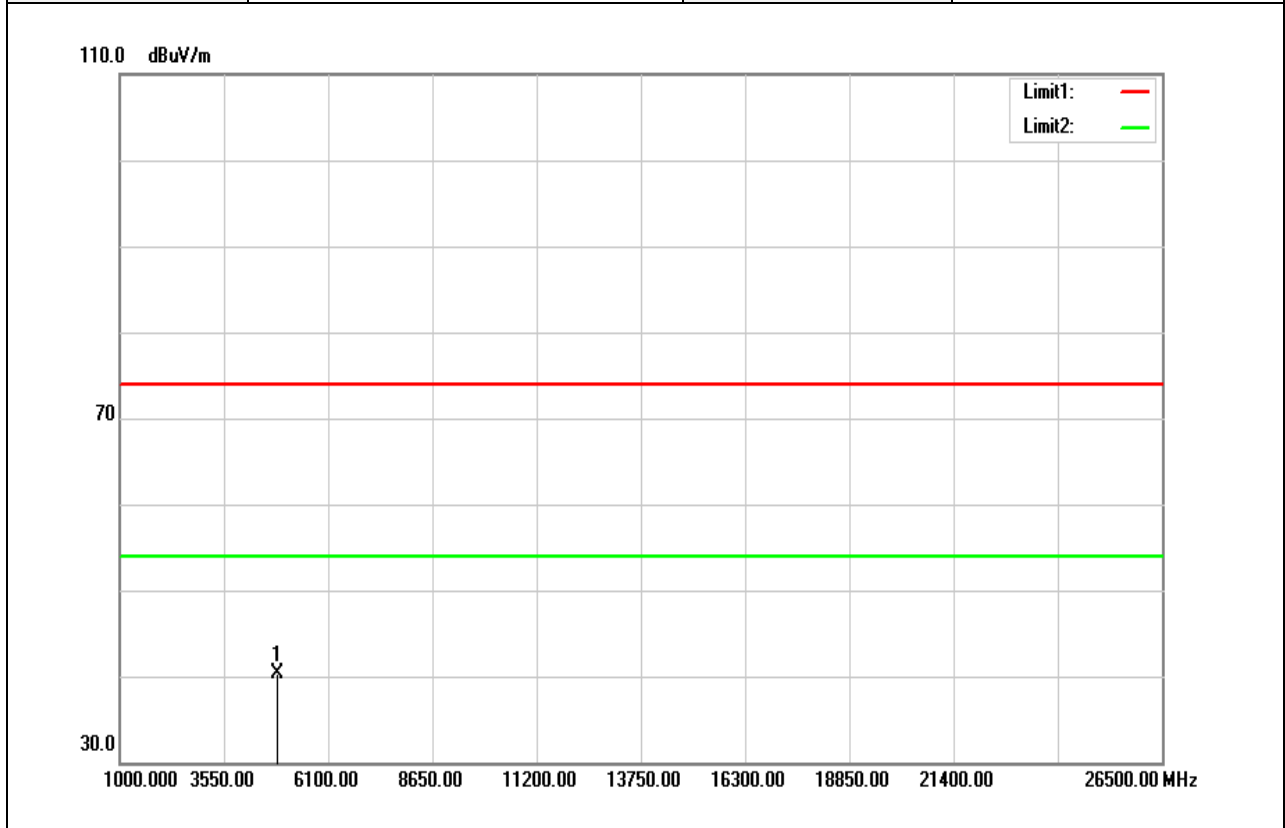

Frequency (MHz)	Reading (dBuV)	Correct Factor (dB/m)	Result (dBuV/m)	Limit (dBuV/m)	Margin (dB)	Remark
4874.000	35.73	4.47	40.20	74.00	-33.80	peak
N/A						

**Remark:**

1. Measuring frequencies from 1 GHz to the 10th harmonic of highest fundamental frequency.
2. For above 1GHz, the EUT peak value was under average limit, therefore the Average value compliance with the average limit

Report No.: T180420W02-RP

Test Mode	IEEE 802.11n HT 20 Mid CH	Temp/Hum	22(°C) / 34%RH
Test Item	Harmonic	Test Date	June 6, 2018
Polarize	Horizontal	Test Engineer	Jerry Chuang
Detector	Peak and Average		

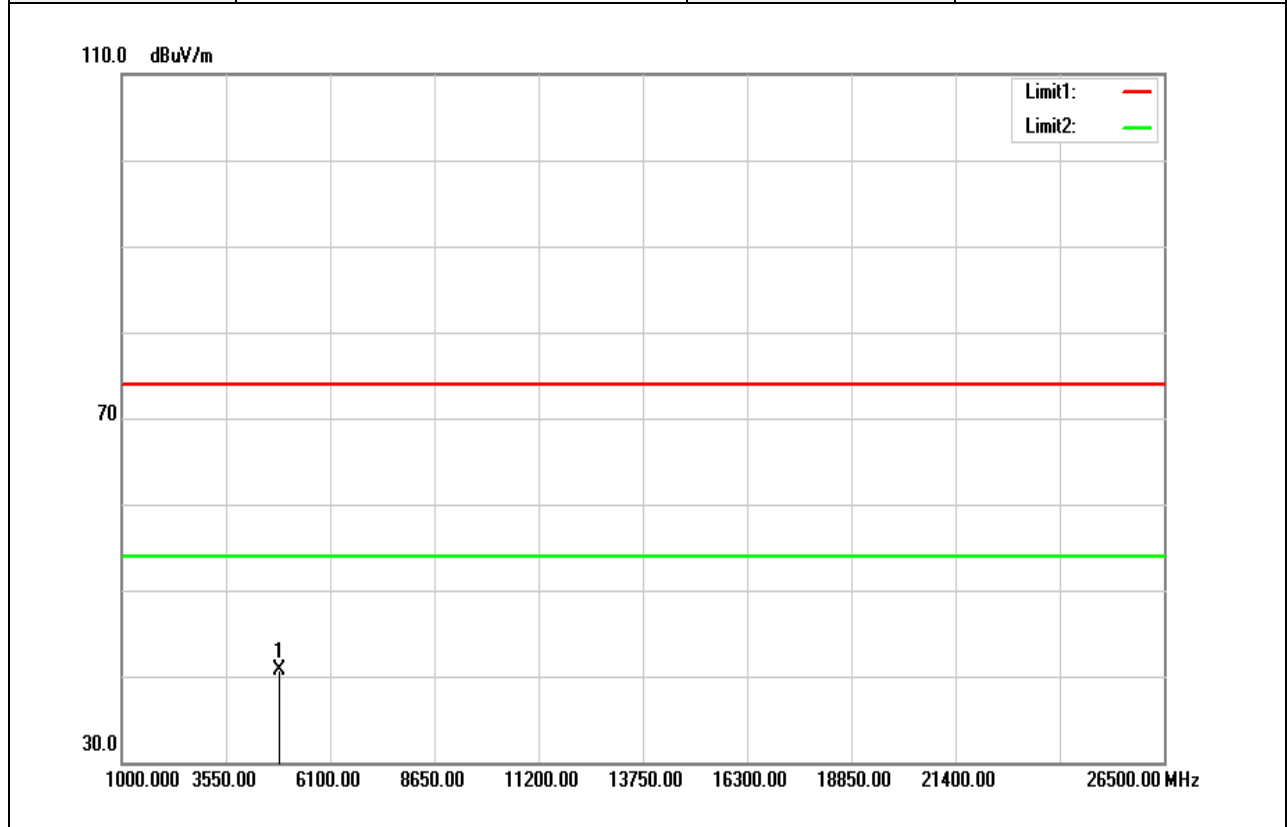

Frequency (MHz)	Reading (dBuV)	Correct Factor (dB/m)	Result (dBuV/m)	Limit (dBuV/m)	Margin (dB)	Remark
4874.000	36.33	4.47	40.80	74.00	-33.20	peak
N/A						

**Remark:**

- Measuring frequencies from 1 GHz to the 10th harmonic of highest fundamental frequency.
- For above 1GHz, the EUT peak value was under average limit, therefore the Average value compliance with the average limit

Test Mode	IEEE 802.11n HT 20 High CH	Temp/Hum	22(°C) / 34%RH
Test Item	Harmonic	Test Date	June 6, 2018
Polarize	Vertical	Test Engineer	Jerry Chuang
Detector	Peak and Average		

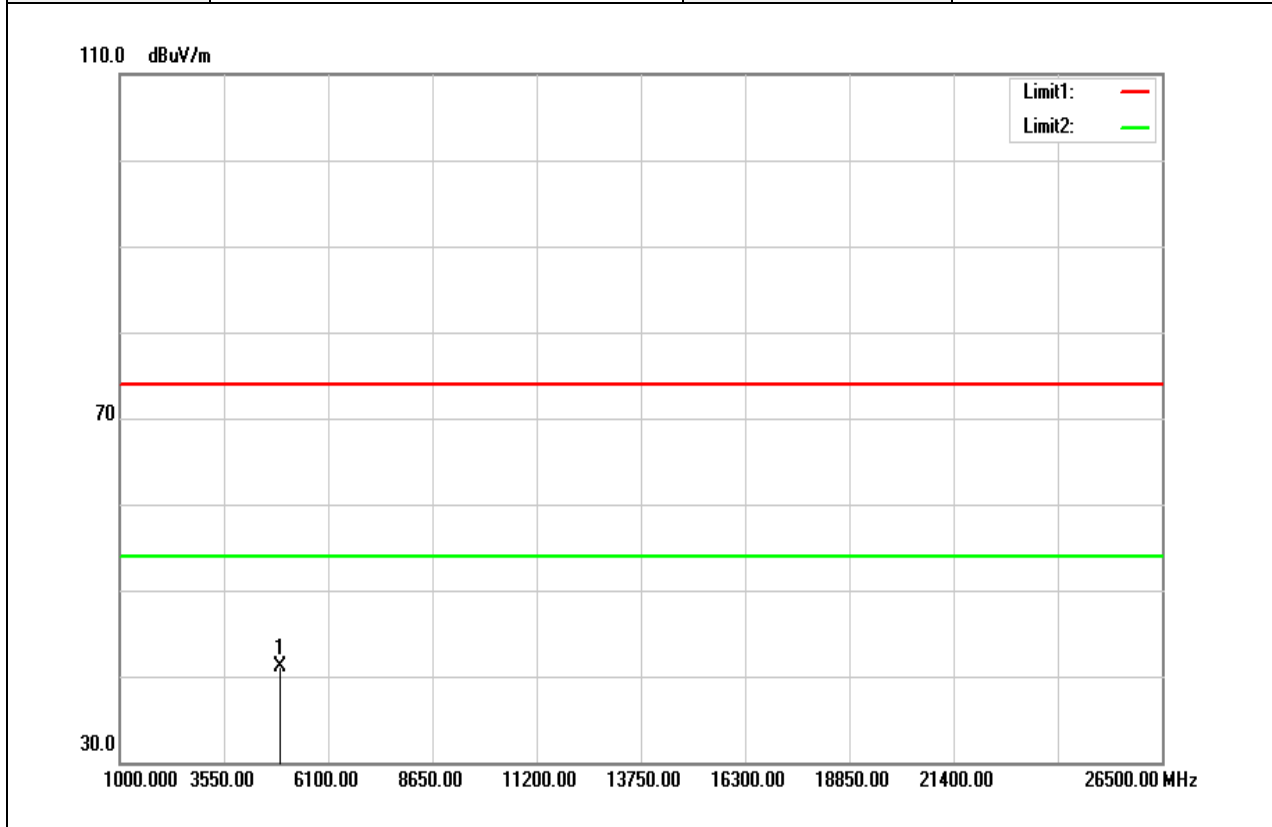

Frequency (MHz)	Reading (dBuV)	Correct Factor (dB/m)	Result (dBuV/m)	Limit (dBuV/m)	Margin (dB)	Remark
4924.000	36.46	4.55	41.01	74.00	-32.99	peak
N/A						

**Remark:**

1. Measuring frequencies from 1 GHz to the 10th harmonic of highest fundamental frequency.
2. For above 1GHz, the EUT peak value was under average limit, therefore the Average value compliance with the average limit

Report No.: T180420W02-RP

Test Mode	IEEE 802.11n HT 20 High CH	Temp/Hum	22(°C) / 34%RH
Test Item	Harmonic	Test Date	June 6, 2018
Polarize	Horizontal	Test Engineer	Jerry Chuang
Detector	Peak and Average		

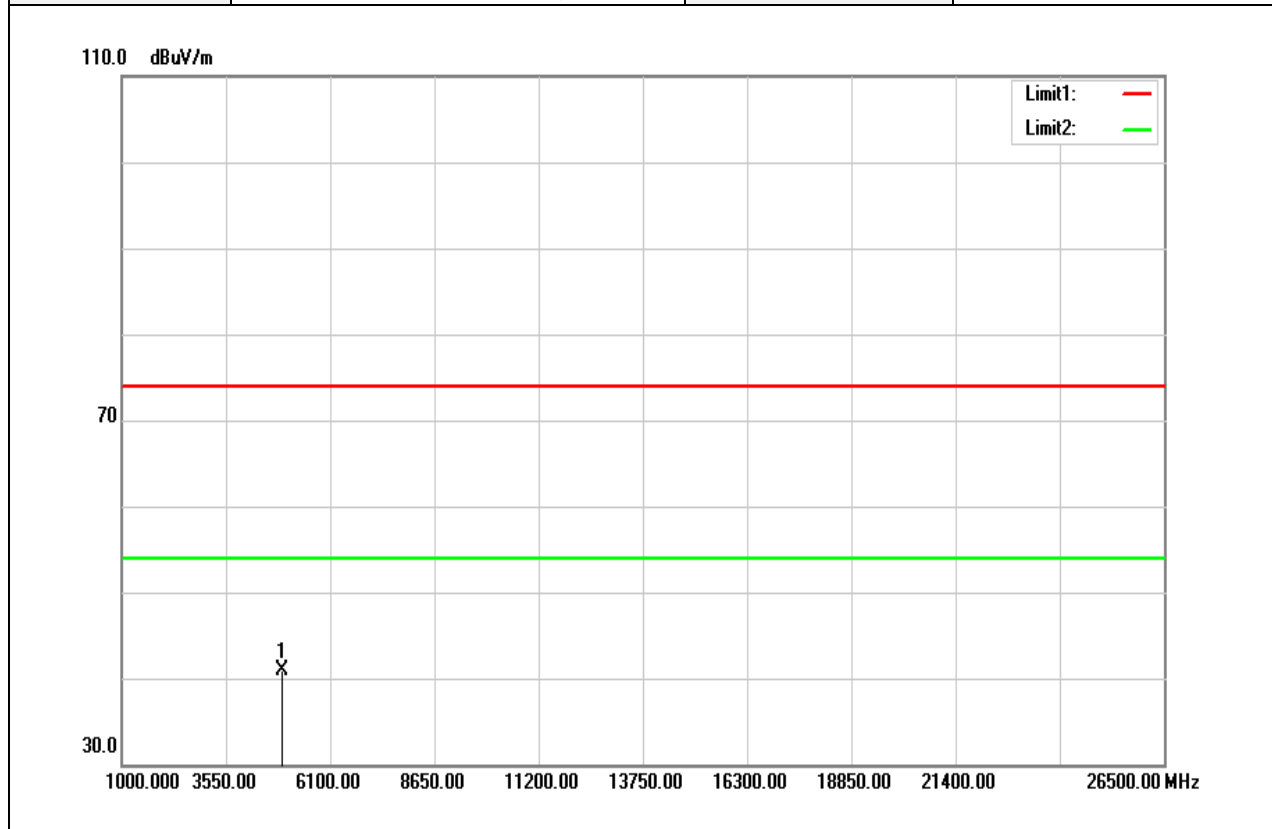

Frequency (MHz)	Reading (dBuV)	Correct Factor (dB/m)	Result (dBuV/m)	Limit (dBuV/m)	Margin (dB)	Remark
4924.000	36.38	4.55	40.93	74.00	-33.07	peak
N/A						

**Remark:**

1. Measuring frequencies from 1 GHz to the 10th harmonic of highest fundamental frequency.
2. For above 1GHz, the EUT peak value was under average limit, therefore the Average value compliance with the average limit

--End of Test Report--

Report No.: T180420W02-RP

## **APPENDIX A Test Photo**

### **Radiation (Below 1GHz)**

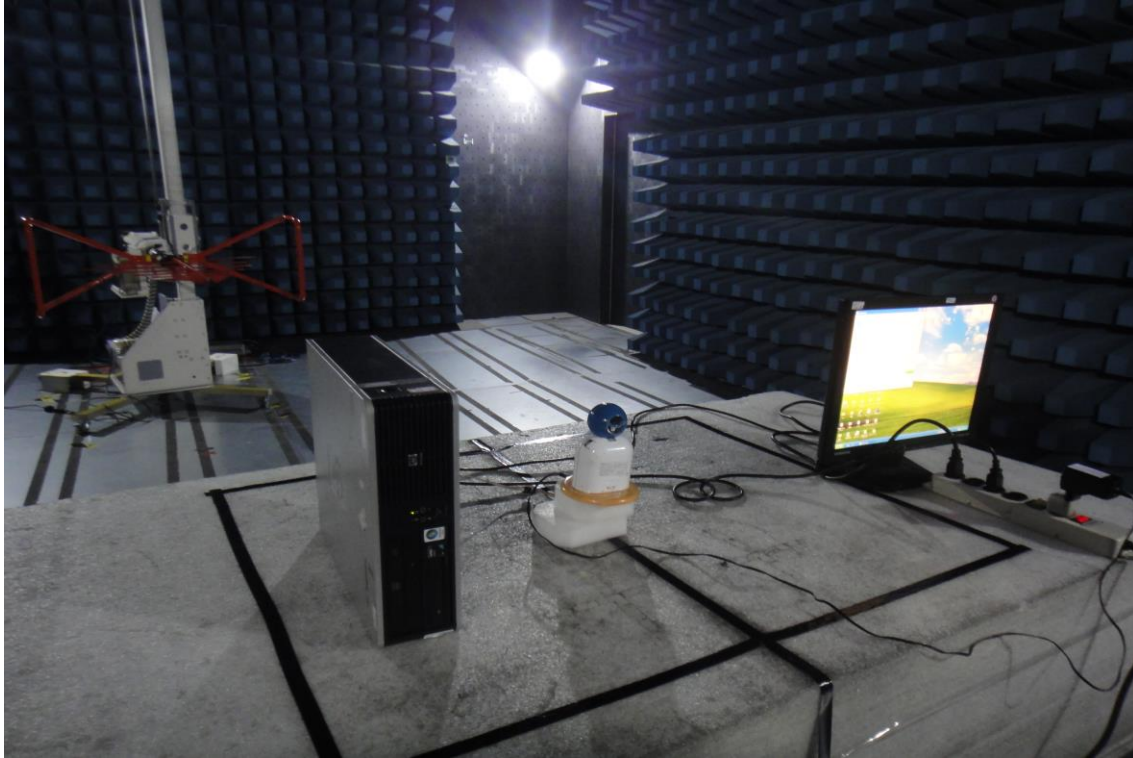

### **Radiation (Above 1GHz)**

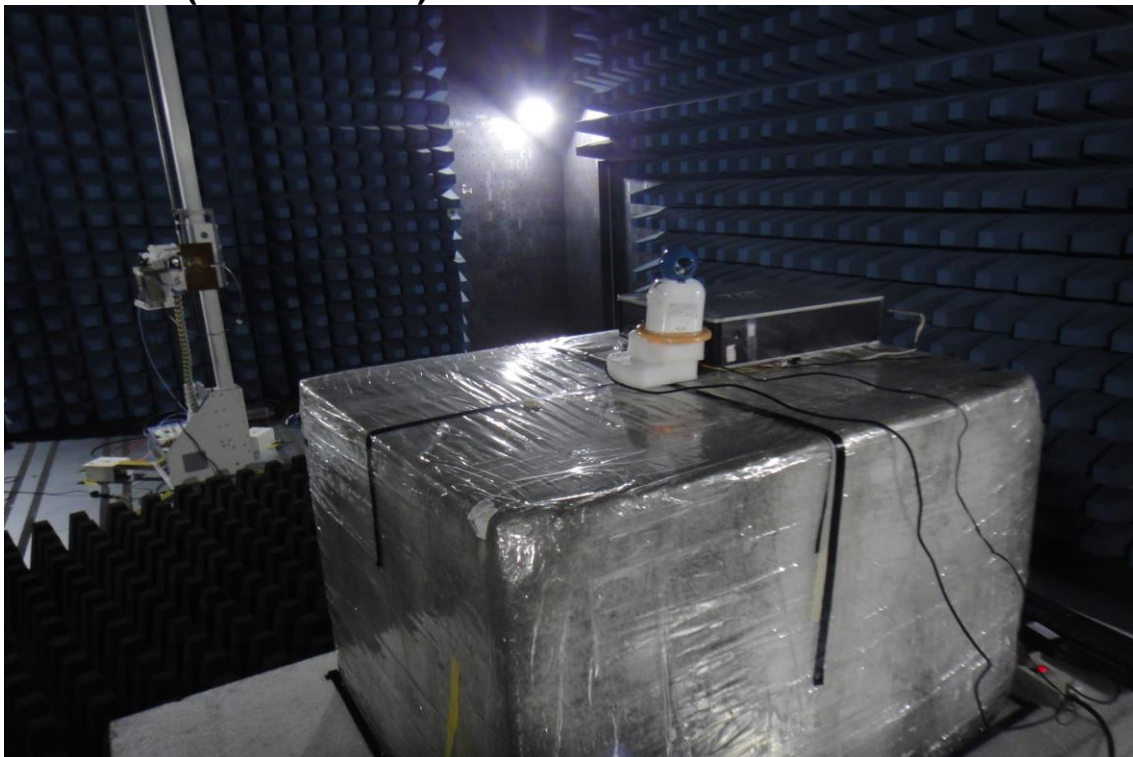

### Conducted Emission Set Up Photo

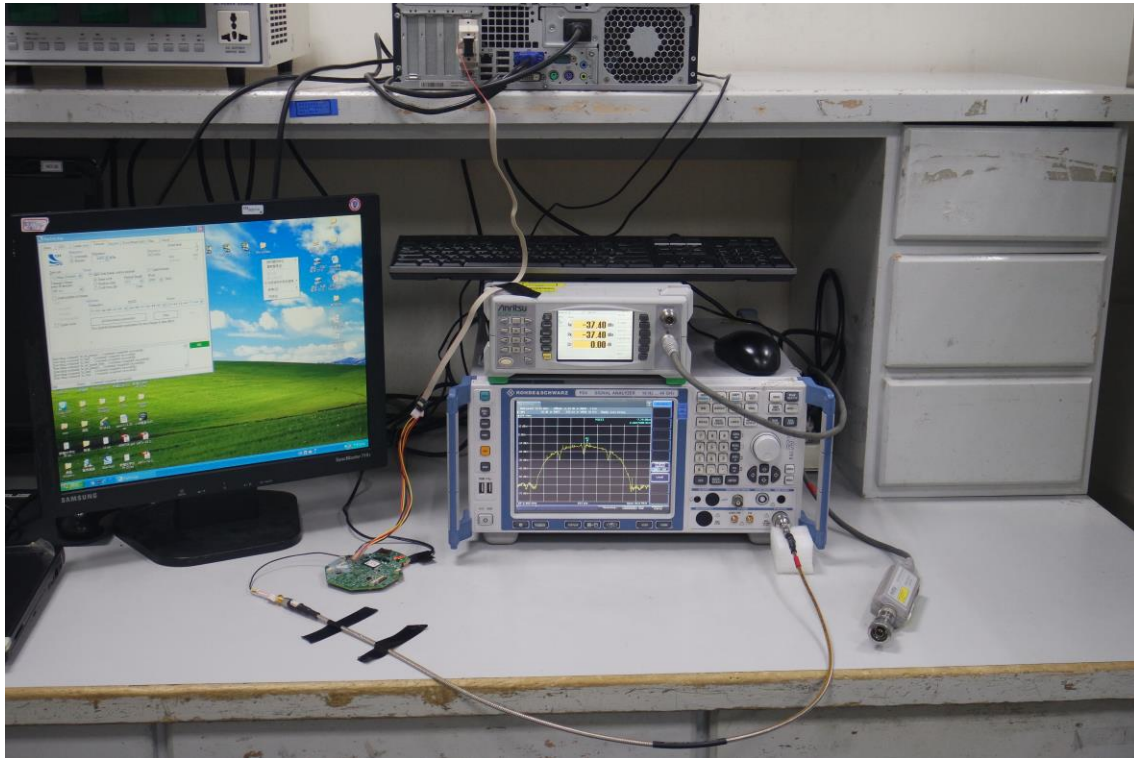



### Conduction

