

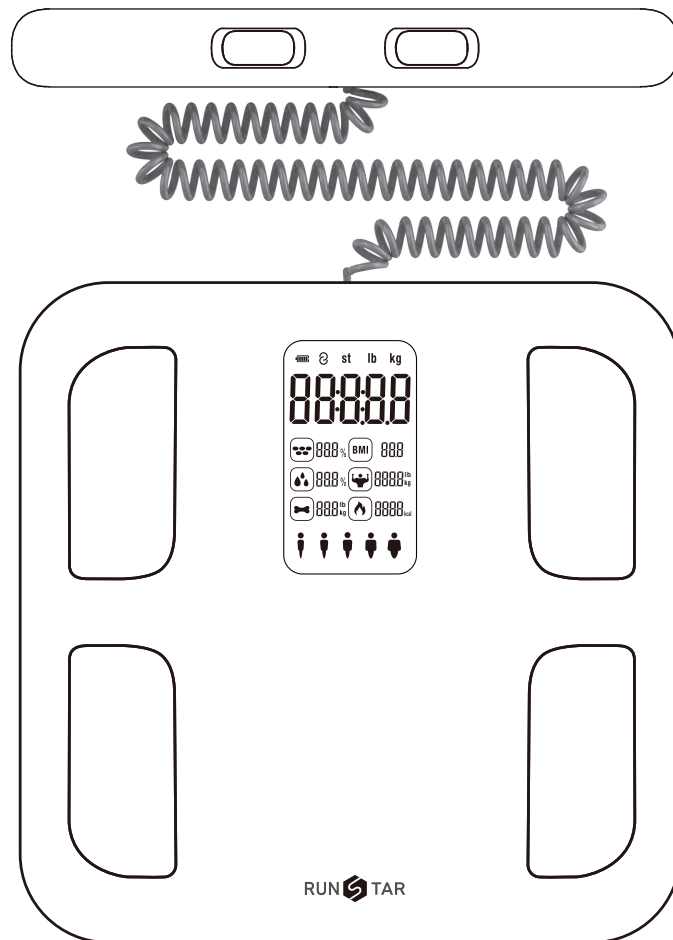

# Smart Full Body Composition Scale

Model No.: FG2001ULB



## Instruction Manual

FCC ID: 2AP3Q-FG2001ULB



Read this manual before using and save for future reference

# Quick Start Guide

1. Download the "Starfit" App from App Store or Google Play.
2. Place the scale on the hard flat surface.
3. Measure with bare feet and fully contact with the electrodes.
4. Turn on the smart App and get the scale connected before measuring.
5. Follow below operations and make sure the posture is correct for measuring.

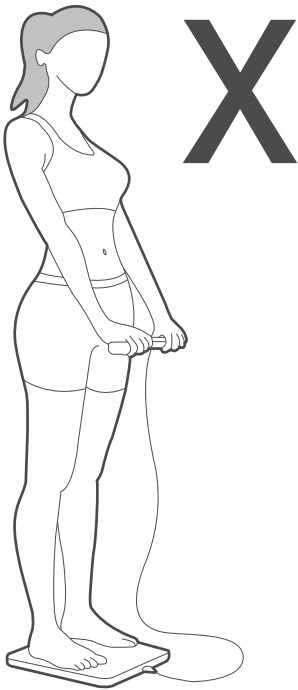

Arms not straight

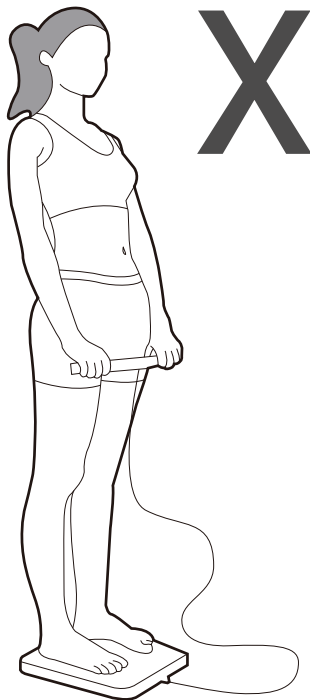

Arms close to waist



Keep your arms straight 45 degrees or 90 degrees

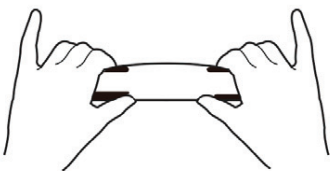

The tail finger does not touch the electrode pad

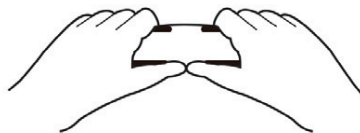

Two thumbs close together

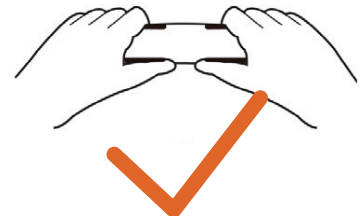

Keep your all fingers touch the electrode pads

## Smart Full Body Composition Scale

Thanks for choosing Smart Full Body Composition Scale. This scale uses bio-electrical impedance analysis (BIA) technology to help you conveniently measure Body weight, Body balance, BMI, Body fat rate, Visceral fat, Body water, Skeletal muscle rate, Muscle mass, Bone mass, Protein, BMR, Body age and etc.

### **WARNING**

- DO NOT use with medical implants such as pacemakers.
- DO NOT stand on the edge of the scale or jump on it;
- DO NOT overload the scale (Max.180kg/396lb/28st)
- DO NOT drop scale or drop the objects on it as this may damage the sensors.
- DO NOT immerse the scale in water or use chemical cleaning agents. Clean the scale with a slightly damp cloth.
- Not recommended for pregnant women.
- Not recommended for infants, toddlers, and children who are under 10 years of age.
- Any measurement obtained using this device is for reference only and should not be considered as a medical opinion.
- DO NOT be used to diagnose or treat any medical condition. You should consult your primary care doctor or physician before making changes to your diet, exercise plan or physical activities.
- Always place the scale on a hard, dry and flat surface before measurement.
- Make sure your feet are dry before stepping on the scale.
- Connect the batteries in accordance with the correct polarities indicated.
- Remove batteries if the scale is not be used for a prolonged period of time
- DO NOT use the device if damaged. The continuous use of a damaged unit may cause injury or improper results. Please check the device before each use.
- First check the batteries power and replace it if needed, if the scale malfunction.
- Be careful when using on the wet and slippery surface.

### Product Specification

Product size:	11.8x11.8 inch
LCD screen display:	4.2x2.4 inch
Weight unit:	lb/kg/st
Weight limit:	11lb-396lb
Weight division:	0.1lb/0.1kg
Power Supply:	Rechargeable lithium cell (USB port)
Operating temperature:	10-40°C
Operation humidity:	40%-80% RH

## Indication Symbols



The batteries in the scales are too weak. Insert new batteries  
(Please charge the scale with type-C cable.).



More than 180kg are on the scales. The scales are overloaded.



An error has occurred during measurement. Step off the scales for 5 seconds and step onto them again to repeat the measuring process.

## Product Overview

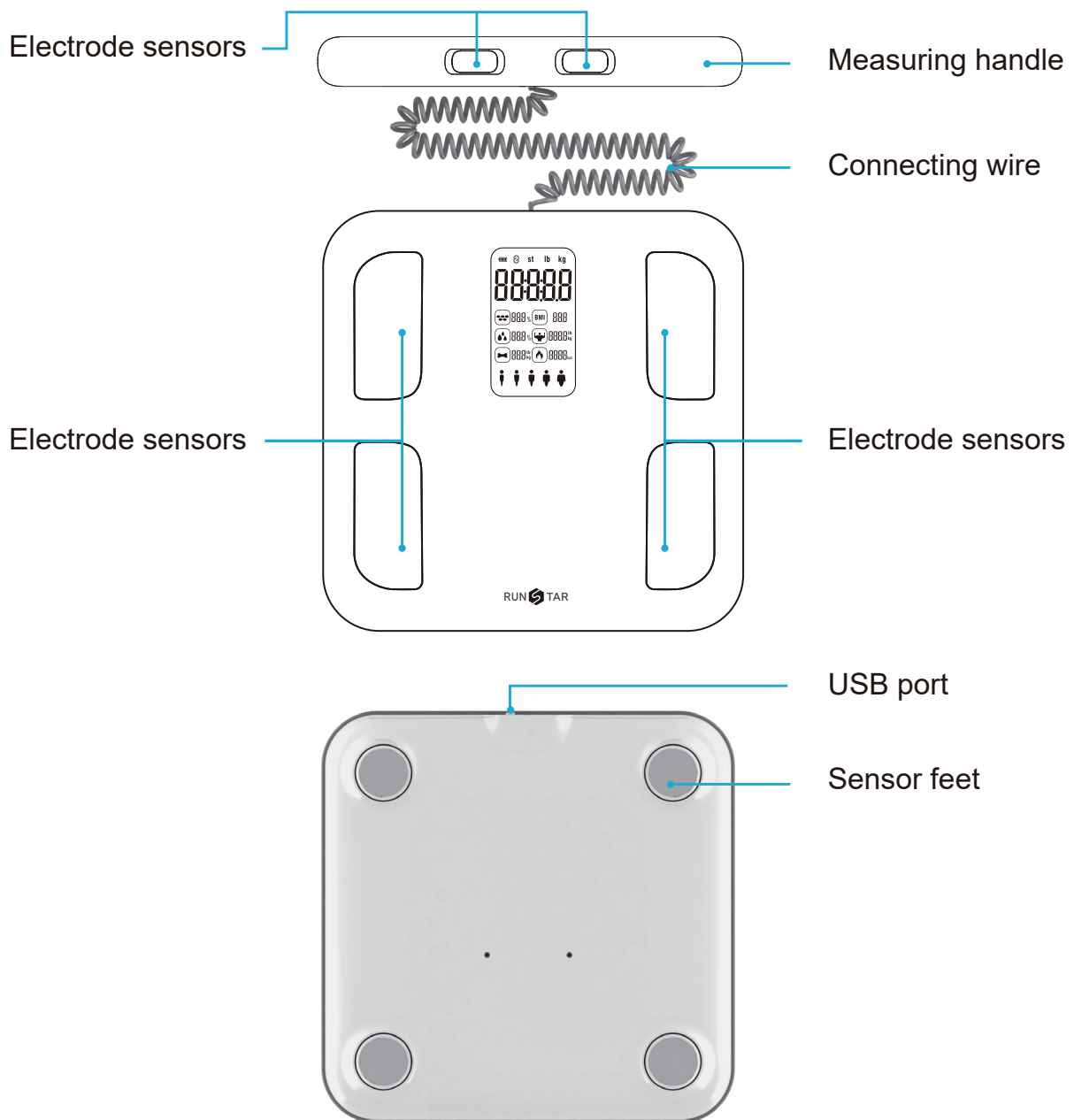

## Indication Symbols

iOS: 8.0 or higher

Android: 5.0 or higher

## Install Starfit App

1.Scan the below QR Code to download APP, or search “Starfit” from App Store and Google Play.



2.Download and install the App “Starfit” on your phone.

3.The App icon will appear on your phone after the installation is completed.

## How to use the scale with Starfit App for the first time?

1.Open the App “Starfit” on your device.

2.Register your own account by email or login with social media account.

3.Add personal data and confirm.

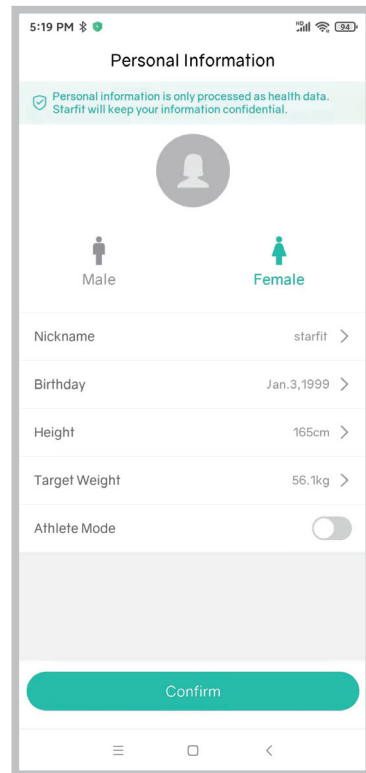
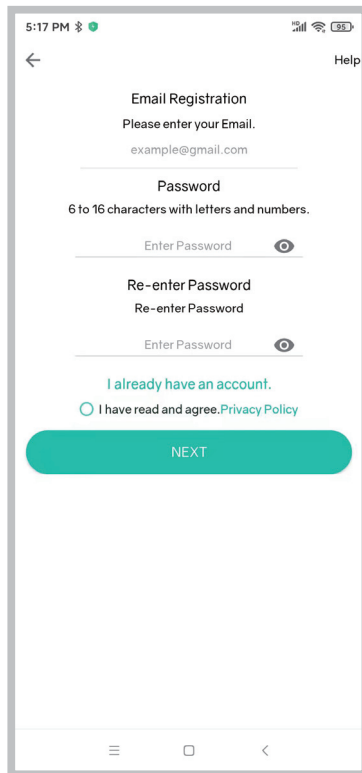
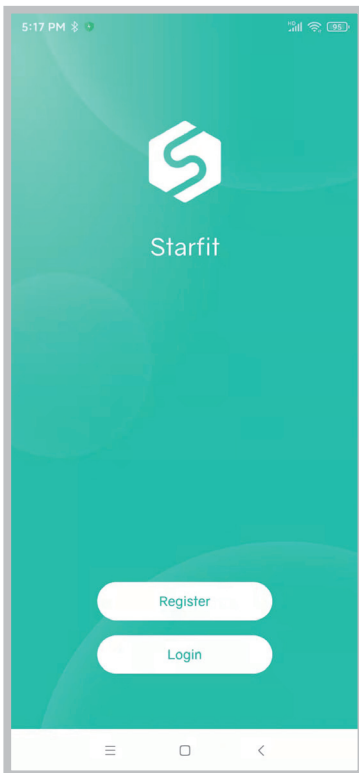

4.iOS: Make sure Bluetooth is on and Bluetooth Authorization is allowed.

Android: Make sure Bluetooth is on and GPS and Location is allowed.

5.In the back of scale, pull out the insulation sheet, then place the scale on a hard, flat surface, step onto the scale with single foot to activate the scale. Wait until the display shows “0.0lb”.

6.Pair the scale through Bluetooth. Make sure the scale is on when pairing. Leaving the APP on its main screen, it will automatically connect to the scale. Or you could also click “Account” ----> “My Devices”----> “+” ----> “Bluetooth” find the scale Bluetooth ID: Runstar-R4.

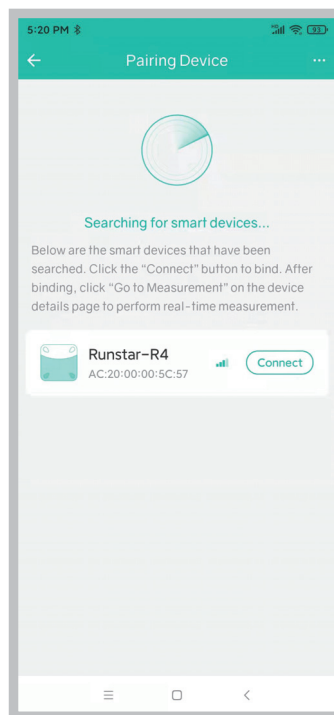
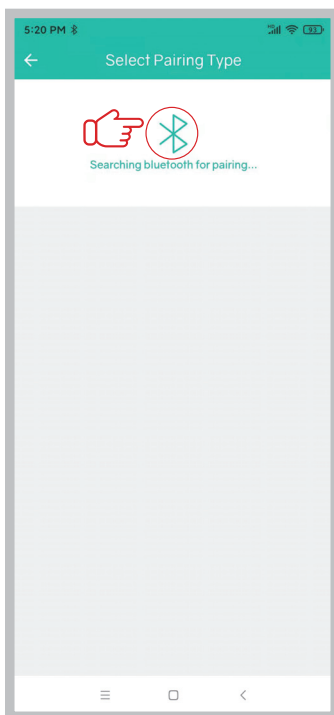
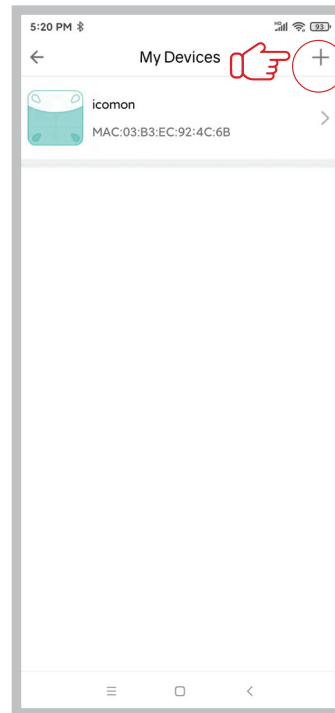
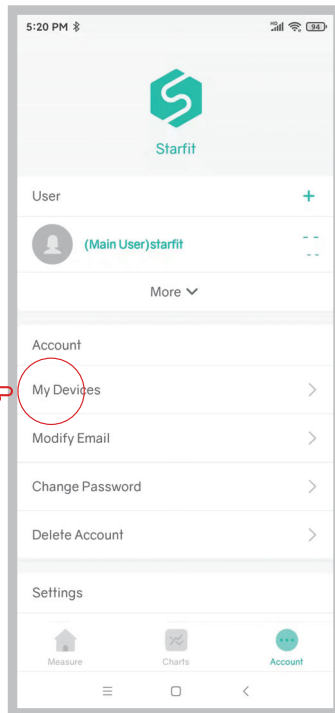
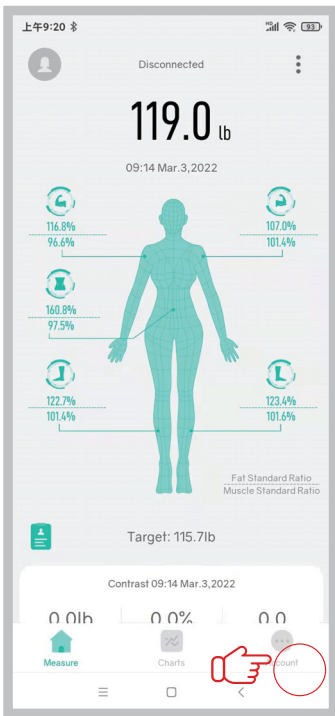

7.The app will show your data within a few seconds.

# Body Composition Analysis Report

Click "  " to view your Body Composition Analysis Report.

You can also click "  " to select save to local, print or share to friend via facebook, instagram, or SMS.

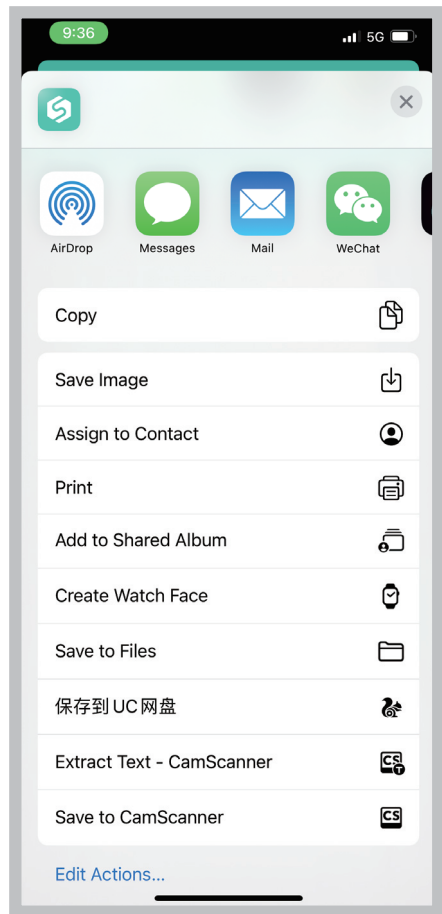
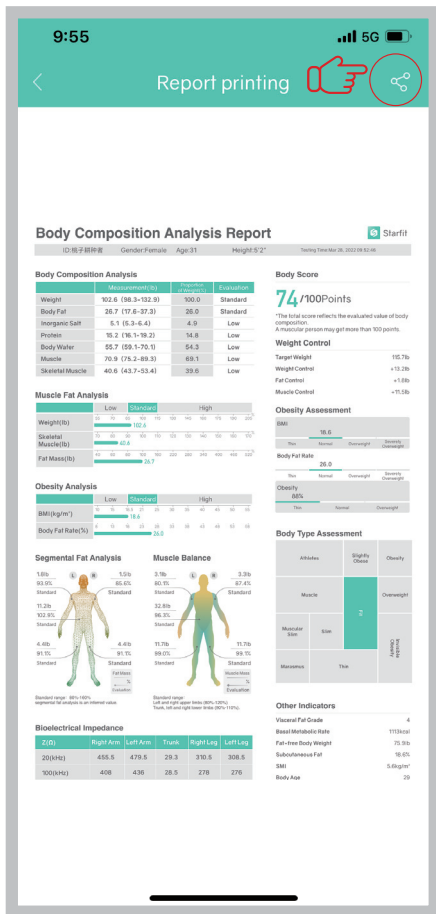
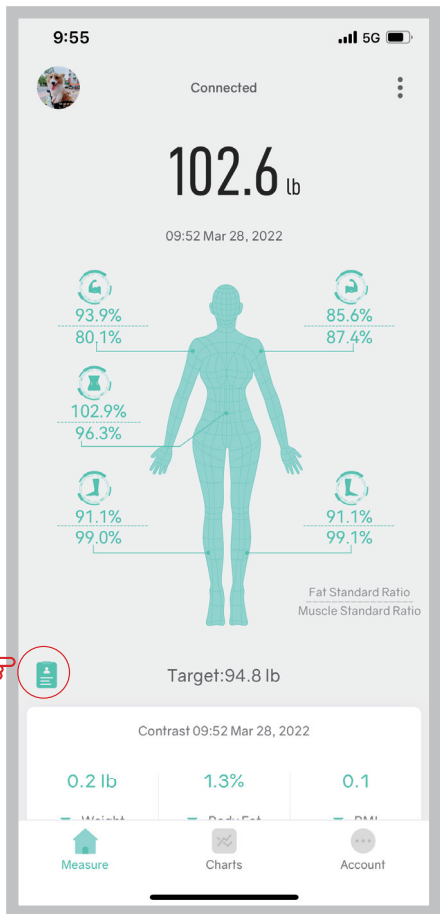

## Bluetooth Connection

### 1) Regular Connection

See the "How to use the scale with Starfit App for the first time?" chapter

2 ) If the regular connection to Bluetooth failed, please try the below steps:

1. Reset the scale by taking out one battery for 5 seconds and putting it back in.
2. Reset the Bluetooth connection. Ensure Bluetooth and GPS (Android only) are enabled on your device.
  - Under the "Account" section, select the "Device". Slide it left to delete the current device.
  - Tap "+" on the top right to enter pairing mode.
  - Step onto the scale with single foot to wake it up.
  - After a few seconds of loading, the scale name will appear, tap and confirm it.
  - Step on the scale again to complete the pairing.

## Troubleshooting

1. Bluetooth failed to connection.

- Make sure the scale and the Bluetooth and GPS (Android only) on your phone are on;
- Check the system version of your smart phone, it must be iOS 8.0 or higher/Android 6.0 higher;
- For successfully connection, there is a Bluetooth icon on the display and the word "Connected" will show on the circle of the homepage on phone;
- If fail to connect via Bluetooth, please click Account--->My Device to find the scale ID: Runstar-R4.

2.No body fat data after weighting.

- Must step onto the scale with bare feet.
- Make sure your feet and the scale are both dry.
- Step off the scale when measurement does not finish (Please keep standing on the scale around 10 second until the number on the display stops flashing).
- Bluetooth is not turned on.
- Bluetooth is paired with a difference scale.

3.Incorrect weight data occurs.

- Check whether the scale is on a hard, flat surface.
- Check each sensor foot on the back to make sure nothing is stuck to the bottom of it.

4.Incorrect fat-muscle ratio shows on App.

- The body parameter settings are incorrect, check to make sure you entered the correct gender, height, and age.
- Check if you activate the Athlete Mode.

5.How do I re-calibrate the scale after removing?

- Step on the scale to turn it on. Let it automatically drop to 0.0lb to calibrate.



6.The scale does not turn on.

- Check if the insulation sheet has been pulled out.
- Check if battery has run out of power and change new batteries if needed.

## Frequently Asked Questions & Answers

### 1.How to get the most accurate result?

- Stand on the scale firmly, do not shake when weigh-in.
- Take your measurement at the same time each day to ensure the most accurate results.
- Please place your scale on the hard/flat ground, then step on the scale with bare feet, after that the display will be turned on.
- Check your profile information (gender, age and height), make sure all the data is accurate.
- Check the place, make sure it is hard/flat, some place seems flat, but actually not, you could try to move to different hard surface until it gets the same result.
- Check the bottom of the scale before measurement, if it is not balanced, the data won't be accurate.
- Make sure that "0.0" shown on the display, before each time use.
- Keep bare feet, with each foot touching both the top and bottom electrode.

### 2.How to restart the scale?

- First, take one of the batteries out of the scale.
- Then, put back the batteries and wait for 5 seconds.
- After the scale has been automatic restart, you can step onto the scale.

### 3.How to change language?

- Starfit APP--->Account--->Settings--->Language

### 4.How to change unit?

- Starfit APP--->Account--->Settings--->Switch units

For more information, please check FQA from Starfit APP. “Account >Settings >FAQ”

## Advice

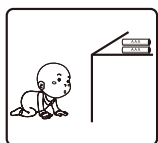

Place the scale far away from the children in case of falling down or crashing.



Do not expose the scale to heat or fire, which will easily cause explosion.



Waste electrical products should not be disposed of with household waste.  
Please recycle where facilities exist.



Check with your local Authority or retailer for recycling advice.

# Holder Usage

---

**1. Please remove the sticker from the included holder and attach it to the wall considering the length of the string.**

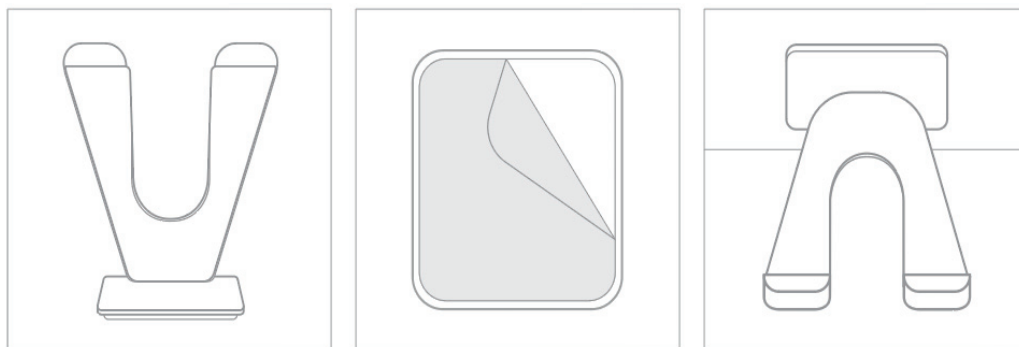

**2. Please place the handle on the holder when it is not used.**

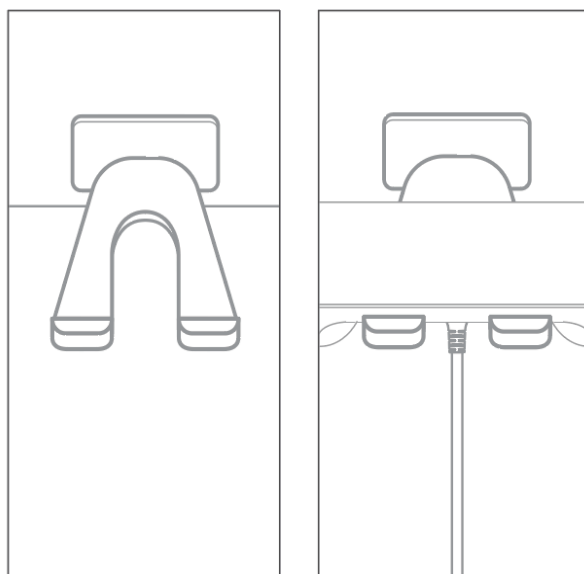

## **Frequently Asked Questions&Answers**

---

### **1.Why doesn't the scale work? Why does the data on screen disappear in a flash?**

- Please check the batteries are installed properly, replace batteries if necessary.

### **2. The scale cannot connect with App.**

- Check that the phone's software is iOS 8.0 or higher or Android6.0 or higher.

- Download and open the newest version of the Starfit App.

- Enable Bluetooth on your phone. For Android 6.0 or higher, location needs to be enabled

### **3.No body fat measured when weighing.**

- Step on with dry and bare feet

- Ensure Bluetooth is enabled and working

- Ensure personal data is entered.

## **Warning Note**

---

Changes or modifications not expressly approved by the party responsible for compliance could void the user's authority to operate the equipment.

## FCC Statement

---

### **Operation is subject to the following two conditions:**

- (1) This device may not cause harmful interference.
- (2) This device must accept any interference received, including interference that may cause undesired operation.

**Note:** This equipment has been tested and found to comply with the limits for a Class B digital device, pursuant to part 15 of the FCC Rules. These limits are designed to provide reasonable protection against harmful interference in a residential installation. This equipment generates, uses and can radiate radio frequency energy and, if not installed and used in accordance with the instructions, may cause harmful interference to radio communications. However, there is no guarantee that interference will not occur in a particular installation. If this equipment does cause harmful interference to radio or television reception, which can be determined by turning the equipment off and on, the user is encouraged to try to correct the interference by one or more of the following measures:

- Reorient or relocate the receiving antenna.
- Increase the separation between the equipment and receiver.
- Connect the equipment into an outlet on a circuit different from that to which the receiver is connected.
- Consult the dealer or an experienced radio/TV technician for help.