



RF TEST REPORT

Applicant Flextronics (Shanghai) Co., Ltd

FCC ID 2AP3PTRINITY

Product FT700 series - In-cab advanced telematics tracker
HT800 series - Rugged advanced telematics tracker

Model FT700-LM0Q-GL, HT800-LM0Q-GL,
HT801-LM0Q-GL

Report No. R1908A0467-R2

Issue Date December 30, 2019

TA Technology (Shanghai) Co., Ltd. tested the above equipment in accordance with the requirements in **FCC CFR47 Part 2 (2018)/ FCC CFR 47 Part 24E (2018)**. The test results show that the equipment tested is capable of demonstrating compliance with the requirements as documented in this report.

Performed by: Peng Tao

Approved by: Kai Xu

TA Technology (Shanghai) Co., Ltd.

No.145, Jintang Rd, Tangzhen Industry Park, Pudong Shanghai, China

TEL: +86-021-50791141/2/3

FAX: +86-021-50791141/2/3-8000



TABLE OF CONTENT

1. Test Laboratory	4
1.1. Notes of the test report.....	4
1.2. Testing Location	4
2. General Description of Equipment under Test.....	5
2.1. Applicant and Manufacturer Information	5
2.2. General information	5
3. Applied Standards.....	7
4. Test Configuration.....	8
5. Test Case Results.....	9
5.1. RF Power Output and Effective Radiated Power	9
5.2. Radiates Spurious Emission	19
6. Main Test Instruments	24



Summary of measurement results

No.	Test Case	Clause in FCC rules	Verdict
1	RF power output and Effective Radiated Power	2.1046 24.232(c)	PASS
2	Radiates Spurious Emission	2.1053 / 24.238(a)	PASS
Note: PASS: The EUT complies with the essential requirements in the standard. FAIL: The EUT does not comply with the essential requirements in the standard.			
Date of Testing: October 15, 2019~ November 19, 2019			

Test values partial duplicated from module BG96(Report No.: RXA1706-0199RF02R1) for FT700-LM0Q-GL, HT800-LM0Q-GL, HT801-LM0Q-GL (Report No.: R1908A0467-R2). There is only tested Radiated Spurious Emissions and Effective Radiated Power for FT700-LM0Q-GL in this report.



1. Test Laboratory

1.1. Notes of the test report

This report shall not be reproduced in full or partial, without the written approval of **TA technology (shanghai) co., Ltd.** The results documented in this report apply only to the tested sample, under the conditions and modes of operation as described herein. Measurement Uncertainties were not taken into account and are published for informational purposes only. This report is written to support regulatory compliance of the applicable standards stated above.

1.2. Testing Location

Company: TA Technology (Shanghai) Co., Ltd.
Address: No.145, Jintang Rd, Tangzhen Industry Park, Pudong
City: Shanghai
Post code: 201201
Country: P. R. China
Contact: Xu Kai
Telephone: +86-021-50791141/2/3
Fax: +86-021-50791141/2/3-8000
Website: <http://www.ta-shanghai.com>
E-mail: xukai@ta-shanghai.com

2. General Description of Equipment under Test

2.1. Applicant and Manufacturer Information

Applicant	Flextronics (Shanghai) Co., Ltd
Applicant address	4F, Bldg. 10, No. 3000 Longdong Ave., Pudong New District, Shanghai 201203
Manufacturer	Flex Industrial, Ltd.
Manufacturer address	Level 3, Alexander House, 35 Cybercity, Ebene, Mauritius

2.2. General information

EUT Description			
Model	FT700-LM0Q-GL, HT800-LM0Q-GL, HT801-LM0Q-GL		
IMEI	015578002000022		
Hardware Version	P2.1		
Software Version	2.2.5		
Power Supply	Battery		
Antenna Type	Internal Antenna/ External Antenna		
Antenna Gain	Internal Antenna GSM1900:1dBi LTE Band 2:1dBi	External Antenna: LTE Band 2: 2.5 dBi	
Test Mode(s)	GSM1900; LTE Band 2;		
Test Modulation	(GSM)GMSK,8PSK; (LTE)QPSK,16QAM		
Maximum E.I.R.P.	GSM1900:	32.26dBm	
	LTE Band 2:	26.43dBm	
Rated Power Supply Voltage	12V		
Extreme Voltage	Minimum: 6V Maximum: 48V		
Extreme Temperature	Lowest: -40°C Highest: +85°C		
Operating Frequency Range(s)	Band	Tx (MHz)	Rx (MHz)
	GSM1900	1850 ~ 1910	1930 ~ 1990
	LTE Band 2	1850 ~ 1910	1930 ~ 1990
EUT Accessory			
Battery 1 (FT700-LM0Q-GL)	Manufacturer: Hangzhou Future Power Technology Co., Ltd Model: FT553561P		
Battery2 (HT800-LM0Q-GL, HT801-LM0Q-GL)	Manufacturer: INVENTUS POWER, INC. – DESIGN CENTER Model: 57484-001		
Note: 1. The information of the EUT is declared by the manufacturer.			



The difference between FT700-LM0Q-GL, HT800-LM0Q-GL, HT801-LM0Q-GL please refer to APOC Difference Information. However, only the worst model FT500-LM0Q-GL will be recorded in this report.

3. Applied Standards

According to the specifications of the manufacturer, it must comply with the requirements of the following standards:

Test standards:

FCC CFR 47 Part 24E (2018)

ANSI C63.26 (2015)

Reference standard:

FCC CFR47 Part 2 (2018)

KDB 971168 D01 Power Meas License Digital Systems v03r01

4. Test Configuration

Radiated measurements are performed by rotating the EUT in three different orthogonal test planes. EUT stand-up position (Z axis), lie-down position (X, Y axis). Receiver antenna polarization (horizontal and vertical), the worst emission was found in position (Z axis, horizontal polarization) and the worst case was recorded.

All mode and data rates and positions and RB size and modulations were investigated.

Subsequently, only the worst case emissions are reported.

The following testing in GSM/ LTE is set based on the maximum RF Output Power.

Test modes are chosen to be reported as the worst case configuration below:

Test items	Modes/Modulation
	GSM 1900
Effective Isotropic Radiated power	GSM GPRS(1Tx slot) EGPRS(1Tx slot)
Radiates Spurious Emission	GSM

Test modes are chosen to be reported as the worst case configuration below for LTE Band 2

Test items	Bandwidth (MHz)						Modulation		RB			Test Channel		
	1.4	3	5	10	15	20	QPSK	16QAM	1	50%	100%	L	M	H
Effective Isotropic Radiated power	O	O	O	O	O	O	O	O	O	O	O	O	O	O
Radiates Spurious Emission	O	-	O	-	-	O	O	-	O	-	-	-	O	-
Note	1. The mark "O" means that this configuration is chosen for testing. 2. The mark "-" means that this configuration is not testing.													

5. Test Case Results

5.1.RF Power Output and Effective Radiated Power

Ambient condition

Temperature	Relative humidity	Pressure
23°C ~25°C	45%~50%	101.5kPa

Methods of Measurement

During the process of the testing, The EUT is controlled by the Base Station Simulator to ensure max power transmission and proper modulation.

The testing follows FCC KDB 971168 v03r01 Section 5.8 and ANSI C63.26 (2015).

- a) Connect the equipment as illustrated. Mount the equipment with the manufacturer specified antenna in a vertical orientation on a manufacturer specified mounting surface located on a non-conducting rotating platform of a RF anechoic chamber (preferred) or a standard radiation site.
- b) Key the transmitter, then rotate the EUT 360° azimuthally and record spectrum analyzer power level (LVL) measurements at angular increments that are sufficiently small to permit resolution of all peaks. If a standard radiation test site is used, raise and lower the test antenna to obtain a maximum reading at each angular increment. (Note: several batteries may be needed to offset the effect of battery voltage droop, which should not exceed 5% of the manufactured specified battery voltage during transmission).
- c) Replace the transmitter under test with a vertically polarized half-wave dipole (or an antenna whose gain is known relative to an ideal half-wave dipole). The center of the antenna should be at the same location as the center of the antenna under test.
- d) Connect the antenna to a signal generator with a known output power and record the path loss (in dB) as LOSS. If a standard radiation test site is used, raise and lower the test antenna to obtain a maximum reading. $LOSS = \text{Generator Output Power (dBm)} - \text{Analyzer reading (dBm)}$
- e) Determine the effective radiated output power at each angular position from the readings in steps b) and d) using the following equation: $ERP \text{ (dBm)} = \text{LVL (dBm)} + \text{LOSS (dB)}$
- f) The maximum ERP is the maximum value determined in the preceding step.
- g) When calculating ERP, in addition to knowing the antenna radiation and matching characteristics, it is necessary to know the loss values of all elements (e.g.transmission line attenuation, mismatches, filters, combiners) interposed between the point where transmitter output power is measured, and the point where power is applied to the antenna. ERP can then be calculated as follows:
 $EIRP \text{ (dBm)} = \text{Output Power (dBm)} - \text{Losses (dB)} + \text{Antenna Gain (dBi)}$
where:dBd refers to gain relative to an ideal dipole.
 $EIRP \text{ (dBm)} = ERP \text{ (dBm)} + 2.15 \text{ (dB.)}$

The RB allocation refers to section 5.1, using the maximum output power configuration.

Test Setup

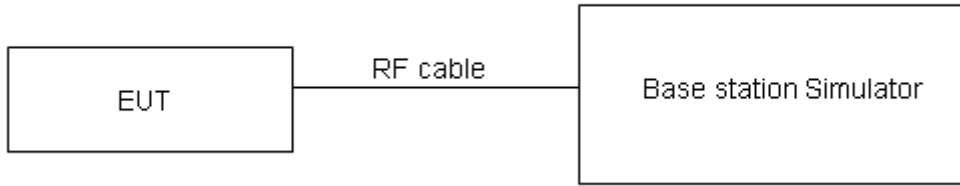

The loss between RF output port of the EUT and the input port of the tester has been taken into consideration.

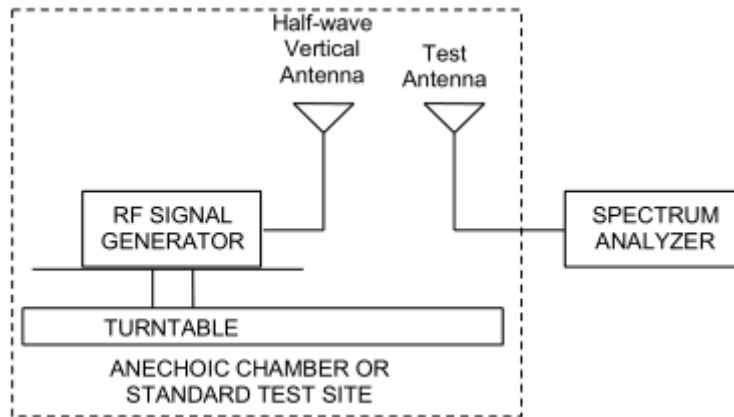
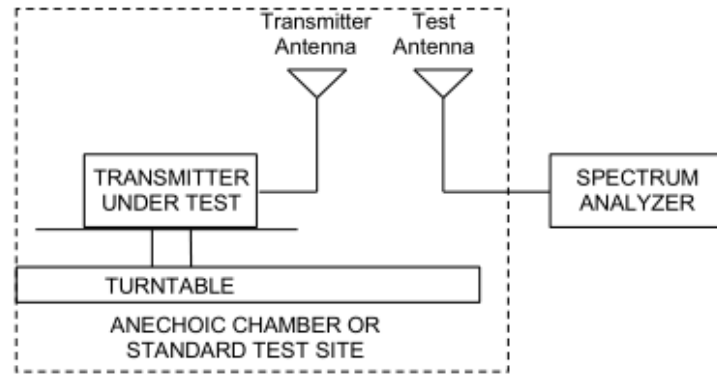

Limits

No specific RF power output requirements in part 2.1046.

Rule Part 24.232(c) Mobile and portable stations are limited to 2 watts EIRP.

Rule Part 24.232(e) Peak transmit power must be measured over any interval of continuous transmission using instrumentation calibrated in terms of an rms-equivalent voltage.

Limit	$\leq 2\text{ W}$ (33 dBm)
-------	----------------------------

**Measurement Uncertainty**

The assessed measurement uncertainty to ensure 95% confidence level for the normal distribution is with the coverage factor $k = 2$, $U = 0.4$ dB for RF power output, $k = 2$, $U = 1.19$ dB for EIRP.



Test Results

Internal Antenna

GSM 1900		Conducted Power (dBm)			EIRP (dBm)		
		Channel 512	Channel 661	Channel 810	Channel 512	Channel 661	Channel 810
		1850.2 (MHz)	1880 (MHz)	1909.8 (MHz)	1850.2 (MHz)	1880 (MHz)	1909.8 (MHz)
GPRS/EGPRS (GMSK)	1TXslot	29.76	29.66	29.46	30.76	30.66	30.46
	2TXslots	29.65	29.57	29.38	30.65	30.57	30.38
	3TXslots	29.51	29.45	29.27	30.51	30.45	30.27
	4TXslots	29.42	29.32	29.16	30.42	30.32	30.16
EGPRS	1TXslot	26.06	25.88	25.84	27.06	26.88	26.84
	2TXslots	25.89	25.81	25.68	26.89	26.81	26.68
	3TXslots	25.78	25.64	25.49	26.78	26.64	26.49
	4TXslots	25.57	25.45	25.38	26.57	26.45	26.38

LTE Band 2				Conducted Power(dBm)			EIRP (dBm)		
BW	Modulation	RB size	RB offset	Channel/Frequency(MHz)					
				18607/1850.7	18900/1880	19193/1909.3	18607/1850.7	18900/1880	19193/1909.3
1.4MHz	QPSK	1	0	23.25	23.37	23.73	24.25	24.37	24.73
		1	2	23.17	23.33	23.73	24.17	24.33	24.73
		1	5	23.22	23.39	23.73	24.22	24.39	24.73
		3	0	23.80	23.66	23.76	24.80	24.66	24.76
		3	2	23.63	23.53	23.65	24.63	24.53	24.65
		3	3	23.43	23.58	23.67	24.43	24.58	24.67
		6	0	23.42	23.55	23.70	24.42	24.55	24.70
	16QAM	1	0	23.80	23.83	23.84	24.80	24.83	24.84
		1	2	23.87	23.83	23.89	24.87	24.83	24.89
		1	5	23.72	23.85	23.79	24.72	24.85	24.79
		3	0	23.53	23.61	23.57	24.53	24.61	24.57
		3	2	23.50	23.62	23.57	24.50	24.62	24.57
		3	3	23.50	23.69	23.50	24.50	24.69	24.50
		6	0	23.52	23.72	23.74	24.52	24.72	24.74
BW	Modulation	RB size	RB offset	Channel/Frequency(MHz)					
				18615/1851.5	18900/1880	19185/1908.5	18615/1851.5	18900/1880	19185/1908.5



3MHz	QPSK	1	0	23.27	23.41	23.76	24.27	24.41	24.76
		1	7	23.20	23.38	23.77	24.20	24.38	24.77
		1	14	23.25	23.44	23.77	24.25	24.44	24.77
		8	0	23.80	23.68	23.79	24.80	24.68	24.79
		8	4	23.65	23.53	23.67	24.65	24.53	24.67
		8	7	23.43	23.59	23.67	24.43	24.59	24.67
		15	0	23.45	23.59	23.73	24.45	24.59	24.73
	16QAM	1	0	23.83	23.85	23.87	24.83	24.85	24.87
		1	7	23.90	23.88	23.93	24.90	24.88	24.93
		1	14	23.74	23.89	23.82	24.74	24.89	24.82
		8	0	23.54	23.64	23.59	24.54	24.64	24.59
		8	4	23.51	23.65	23.59	24.51	24.65	24.59
		8	7	23.50	23.71	23.53	24.50	24.71	24.53
		15	0	23.55	23.76	23.77	24.55	24.76	24.77
BW	Modulation	RB size	RB offset	Channel/Frequency(MHz)					
				18625/ 1852.5	18900/ 1880	19175/ 1907.5	18625/ 1852.5	18900/ 1880	19175/ 1907.5
5MHz	QPSK	1	0	23.24	23.39	23.72	24.24	24.39	24.72
		1	13	23.18	23.34	23.74	24.18	24.34	24.74
		1	24	23.22	23.39	23.73	24.22	24.39	24.73
		12	0	23.77	23.63	23.75	24.77	24.63	24.75
		12	6	23.63	23.49	23.62	24.63	24.49	24.62
		12	13	23.41	23.57	23.63	24.41	24.57	24.63
		25	0	23.43	23.58	23.71	24.43	24.58	24.71
	16QAM	1	0	23.80	23.81	23.84	24.80	24.81	24.84
		1	13	23.87	23.86	23.90	24.87	24.86	24.90
		1	24	23.71	23.87	23.78	24.71	24.87	24.78
		12	0	23.52	23.60	23.56	24.52	24.60	24.56
		12	6	23.48	23.60	23.55	24.48	24.60	24.55
		12	13	23.47	23.66	23.49	24.47	24.66	24.49
		25	0	23.53	23.72	23.72	24.53	24.72	24.72
BW	Modulation	RB size	RB offset	Channel/Frequency(MHz)					
				18650/ 1855	18900/ 1880	19150/ 1905	18650/ 1855	18900/ 1880	19150/ 1905
10MHz	QPSK	1	0	23.26	23.40	23.75	24.26	24.40	24.75
		1	25	23.21	23.39	23.78	24.21	24.39	24.78
		1	49	23.24	23.43	23.76	24.24	24.43	24.76



		25	0	23.80	23.68	23.79	24.80	24.68	24.79
		25	13	23.66	23.54	23.66	24.66	24.54	24.66
		25	25	23.43	23.61	23.68	24.43	24.61	24.68
		50	0	23.51	23.60	23.75	24.51	24.60	24.75
	16QAM	1	0	23.82	23.84	23.86	24.82	24.84	24.86
		1	25	23.90	23.90	23.93	24.90	24.90	24.93
		1	49	23.74	23.89	23.81	24.74	24.89	24.81
		25	0	23.55	23.65	23.60	24.55	24.65	24.60
		25	13	23.50	23.64	23.58	24.50	24.64	24.58
		25	25	23.50	23.71	23.53	24.50	24.71	24.53
50	0	23.56	23.77	23.76	24.56	24.77	24.76		
BW	Modulation	RB size	RB offset	Channel/Frequency(MHz)					
				18675/1857.5	18900/1880	19125/1902.5	18675/1857.5	18900/1880	19125/1902.5
15MHz	QPSK	1	0	23.25	23.36	23.73	24.25	24.36	24.73
		1	38	23.19	23.38	23.75	24.19	24.38	24.75
		1	74	23.21	23.38	23.72	24.21	24.38	24.72
		36	0	23.78	23.64	23.76	24.78	24.64	24.76
		36	18	23.63	23.49	23.62	24.63	24.49	24.62
		36	39	23.40	23.58	23.64	24.40	24.58	24.64
		75	0	23.49	23.56	23.70	24.49	24.56	24.70
	16QAM	1	0	23.77	23.82	23.84	24.77	24.82	24.84
		1	38	23.88	23.87	23.91	24.88	24.87	24.91
		1	74	23.71	23.85	23.78	24.71	24.85	24.78
		36	0	23.52	23.63	23.57	24.52	24.63	24.57
		36	18	23.47	23.59	23.54	24.47	24.59	24.54
		36	39	23.48	23.67	23.50	24.48	24.67	24.50
		75	0	23.53	23.72	23.72	24.53	24.72	24.72
BW	Modulation	RB size	RB offset	Channel/Frequency(MHz)					
				18700/1860	18900/1880	19100/1900	18700/1860	18900/1880	19100/1900
20MHz	QPSK	1	0	23.22	23.32	23.70	24.22	24.32	24.70
		1	50	23.18	23.34	23.73	24.18	24.34	24.73
		1	99	23.19	23.37	23.69	24.19	24.37	24.69
		50	0	23.75	23.59	23.72	24.75	24.59	24.72
		50	25	23.61	23.45	23.59	24.61	24.45	24.59
		50	50	23.37	23.53	23.60	24.37	24.53	24.60



		100	0	23.46	23.51	23.66	24.46	24.51	24.66
	16QAM	1	0	23.75	23.78	23.79	24.75	24.78	24.79
		1	50	23.84	23.85	23.87	24.84	24.85	24.87
		1	99	23.69	23.82	23.76	24.69	24.82	24.76
		50	0	23.49	23.59	23.54	24.49	24.59	24.54
		50	25	23.44	23.57	23.51	24.44	24.57	24.51
		50	50	23.45	23.62	23.46	24.45	24.62	24.46
		100	0	23.51	23.68	23.69	24.51	24.68	24.69

External Antenna

LTE Band 2				Conducted Power(dBm)			EIRP (dBm)		
BW	Modulation	RB size	RB offset	Channel/Frequency(MHz)					
				18607/ 1850.7	18900/ 1880	19193/ 1909.3	18607/ 1850.7	18900/ 1880	19193/ 1909.3
1.4MHz	QPSK	1	0	23.25	23.37	23.73	25.75	25.87	26.23
		1	2	23.17	23.33	23.73	25.67	25.83	26.23
		1	5	23.22	23.39	23.73	25.72	25.89	26.23
		3	0	23.80	23.66	23.76	26.30	26.16	26.26
		3	2	23.63	23.53	23.65	26.13	26.03	26.15
		3	3	23.43	23.58	23.67	25.93	26.08	26.17
		6	0	23.42	23.55	23.70	25.92	26.05	26.20
	16QAM	1	0	23.80	23.83	23.84	26.30	26.33	26.34
		1	2	23.87	23.83	23.89	26.37	26.33	26.39
		1	5	23.72	23.85	23.79	26.22	26.35	26.29
		3	0	23.53	23.61	23.57	26.03	26.11	26.07
		3	2	23.50	23.62	23.57	26.00	26.12	26.07
		3	3	23.50	23.69	23.50	26.00	26.19	26.00
		6	0	23.52	23.72	23.74	26.02	26.22	26.24
BW	Modulation	RB size	RB offset	Channel/Frequency(MHz)					
				18615/ 1851.5	18900/ 1880	19185/ 1908.5	18615/ 1851.5	18900/ 1880	19185/ 1908.5
3MHz	QPSK	1	0	23.27	23.41	23.76	25.77	25.91	26.26
		1	7	23.20	23.38	23.77	25.70	25.88	26.27
		1	14	23.25	23.44	23.77	25.75	25.94	26.27
		8	0	23.80	23.68	23.79	26.30	26.18	26.29
		8	4	23.65	23.53	23.67	26.15	26.03	26.17
		8	7	23.43	23.59	23.67	25.93	26.09	26.17

		15	0	23.45	23.59	23.73	25.95	26.09	26.23
	16QAM	1	0	23.83	23.85	23.87	26.33	26.35	26.37
		1	7	23.90	23.88	23.93	26.40	26.38	26.43
		1	14	23.74	23.89	23.82	26.24	26.39	26.32
		8	0	23.54	23.64	23.59	26.04	26.14	26.09
		8	4	23.51	23.65	23.59	26.01	26.15	26.09
		8	7	23.50	23.71	23.53	26.00	26.21	26.03
		15	0	23.55	23.76	23.77	26.05	26.26	26.27
BW	Modulation	RB size	RB offset	Channel/Frequency(MHz)					
				18625/ 1852.5	18900/ 1880	19175/ 1907.5	18625/ 1852.5	18900/ 1880	19175/ 1907.5
5MHz	QPSK	1	0	23.24	23.39	23.72	25.74	25.89	26.22
		1	13	23.18	23.34	23.74	25.68	25.84	26.24
		1	24	23.22	23.39	23.73	25.72	25.89	26.23
		12	0	23.77	23.63	23.75	26.27	26.13	26.25
		12	6	23.63	23.49	23.62	26.13	25.99	26.12
		12	13	23.41	23.57	23.63	25.91	26.07	26.13
		25	0	23.43	23.58	23.71	25.93	26.08	26.21
	16QAM	1	0	23.80	23.81	23.84	26.30	26.31	26.34
		1	13	23.87	23.86	23.90	26.37	26.36	26.40
		1	24	23.71	23.87	23.78	26.21	26.37	26.28
		12	0	23.52	23.60	23.56	26.02	26.10	26.06
		12	6	23.48	23.60	23.55	25.98	26.10	26.05
		12	13	23.47	23.66	23.49	25.97	26.16	25.99
		25	0	23.53	23.72	23.72	26.03	26.22	26.22
BW	Modulation	RB size	RB offset	Channel/Frequency(MHz)					
				18650/ 1855	18900/ 1880	19150/ 1905	18650/ 1855	18900/ 1880	19150/ 1905
10MHz	QPSK	1	0	23.26	23.40	23.75	25.76	25.90	26.25
		1	25	23.21	23.39	23.78	25.71	25.89	26.28
		1	49	23.24	23.43	23.76	25.74	25.93	26.26
		25	0	23.80	23.68	23.79	26.30	26.18	26.29
		25	13	23.66	23.54	23.66	26.16	26.04	26.16
		25	25	23.43	23.61	23.68	25.93	26.11	26.18
		50	0	23.51	23.60	23.75	26.01	26.10	26.25
	16QAM	1	0	23.82	23.84	23.86	26.32	26.34	26.36
		1	25	23.90	23.90	23.93	26.40	26.40	26.43



BW	Modulation	RB size	RB offset	Channel/Frequency(MHz)					
				18675/ 1857.5	18900/ 1880	19125/ 1902.5	18675/ 1857.5	18900/ 1880	19125/ 1902.5
				1	49	23.74	23.89	23.81	26.24
		25	0	23.55	23.65	23.60	26.05	26.15	26.10
		25	13	23.50	23.64	23.58	26.00	26.14	26.08
		25	25	23.50	23.71	23.53	26.00	26.21	26.03
		50	0	23.56	23.77	23.76	26.06	26.27	26.26
15MHz	QPSK	1	0	23.25	23.36	23.73	25.75	25.86	26.23
		1	38	23.19	23.38	23.75	25.69	25.88	26.25
		1	74	23.21	23.38	23.72	25.71	25.88	26.22
		36	0	23.78	23.64	23.76	26.28	26.14	26.26
		36	18	23.63	23.49	23.62	26.13	25.99	26.12
		36	39	23.40	23.58	23.64	25.90	26.08	26.14
		75	0	23.49	23.56	23.70	25.99	26.06	26.20
	16QAM	1	0	23.77	23.82	23.84	26.27	26.32	26.34
		1	38	23.88	23.87	23.91	26.38	26.37	26.41
		1	74	23.71	23.85	23.78	26.21	26.35	26.28
		36	0	23.52	23.63	23.57	26.02	26.13	26.07
		36	18	23.47	23.59	23.54	25.97	26.09	26.04
		36	39	23.48	23.67	23.50	25.98	26.17	26.00
		75	0	23.53	23.72	23.72	26.03	26.22	26.22
20MHz	QPSK	1	0	23.22	23.32	23.70	25.72	25.82	26.20
		1	50	23.18	23.34	23.73	25.68	25.84	26.23
		1	99	23.19	23.37	23.69	25.69	25.87	26.19
		50	0	23.75	23.59	23.72	26.25	26.09	26.22
		50	25	23.61	23.45	23.59	26.11	25.95	26.09
		50	50	23.37	23.53	23.60	25.87	26.03	26.10
		100	0	23.46	23.51	23.66	25.96	26.01	26.16
	16QAM	1	0	23.75	23.78	23.79	26.25	26.28	26.29
		1	50	23.84	23.85	23.87	26.34	26.35	26.37
		1	99	23.69	23.82	23.76	26.19	26.32	26.26
		50	0	23.49	23.59	23.54	25.99	26.09	26.04
		50	25	23.44	23.57	23.51	25.94	26.07	26.01



		50	50	23.45	23.62	23.46	25.95	26.12	25.96
		100	0	23.51	23.68	23.69	26.01	26.18	26.19

5.2. Radiates Spurious Emission

Ambient condition

Temperature	Relative humidity	Pressure
23°C ~25°C	45%~50%	101.5kPa

Method of Measurement

1. The testing follows FCC KDB 971168 v03r01 Section 5.8 and ANSI C63.26 (2015).
2. Below 1GHz: The EUT is placed on a turntable 0.8 meters above the ground in the chamber, 3 meter away from the antenna. The maximal emission value is acquired by adjusting the antenna height, polarisation and turntable azimuth. Normally, the height range of antenna is 1 m to 4 m, the azimuth range of turntable is 0° to 360°, and the receive antenna has two polarizations Vertical (V) and Horizontal (H). Above 1GHz: (Note: the FCC's permission to use 1.5m as an alternative per TCBC Conf call of Dec. 2, 2014.) The EUT is placed on a turntable 1.5 meters above the ground in the chamber, 3 meter away from the antenna. The maximal emission value is acquired by adjusting the antenna height, polarisation and turntable azimuth. Normally, the height range of antenna is 1 m to 4 m, the azimuth range of turntable is 0° to 360°, and the receive antenna has two polarizations Vertical (V) and Horizontal (H).
3. A loop antenna, A log-periodic antenna or horn antenna shall be substituted in place of the EUT. The log-periodic antenna will be driven by a signal generator and the level will be adjusted till the same power value on the spectrum analyzer or receiver. The level of the spurious emissions can be calculated through the level of the signal generator, cable loss, the gain of the substitution antenna and the reading of the spectrum analyzer or receiver.
4. The EUT is then put into continuously transmitting mode at its maximum power level during the test. Set Test Receiver or Spectrum RBW=200Hz,VBW=600Hz for 9kHz150kHz , RBW=10kHz, VBW=30kHz 150kHz-30MHz , RBW=100kHz,VBW=300kHz for 30MHz to 1GHz and RBW=1MHz, VBW=3MHz for above 1GHz, And the maximum value of the receiver should be recorded as (Pr).
5. The EUT shall be replaced by a substitution antenna. In the chamber, an substitution antenna for the frequency band of interest is placed at the reference point of the chamber. An RF Signal source for the frequency band of interest is connected to the substitution antenna with a cable that has been constructed to not interfere with the radiation pattern of the antenna. A power (PMea) is applied to the input of the substitution antenna, and adjust the level of the signal generator output until the value of the receiver reach the previously recorded (Pr). The power of signal source (PMea) is recorded. The test should be performed by rotating the test item and adjusting the receiving antenna polarization.
6. A amplifier should be connected to the Signal Source output port. And the cable should be connect between the Amplifier and the Substitution Antenna. The cable loss (Pcl) ,the Substitution Antenna Gain (Ga) and the Amplifier Gain (PAg) should be recorded after test.
7. The measurement results are obtained as described below:
Power(EIRP)=PMea- PAg - Pcl + Ga
The measurement results are amend as described below:
Power(EIRP)=PMea- Pcl + Ga
8. This value is EIRP since the measurement is calibrated using an antenna of known gain (2.15 dBi)

and known input power. ERP can be calculated from EIRP by subtracting the gain of the dipole, $ERP = EIRP - 2.15\text{dBi}$.

The modulation mode and RB allocation refer to section 5.1, using the maximum output power configuration.

Test setup

9KHz ~ 30MHz

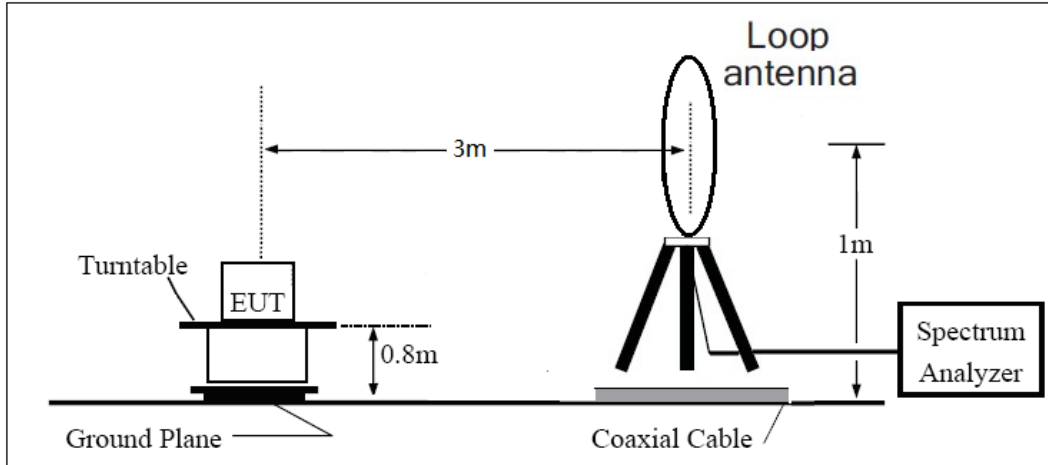

30MHz ~ 1GHz

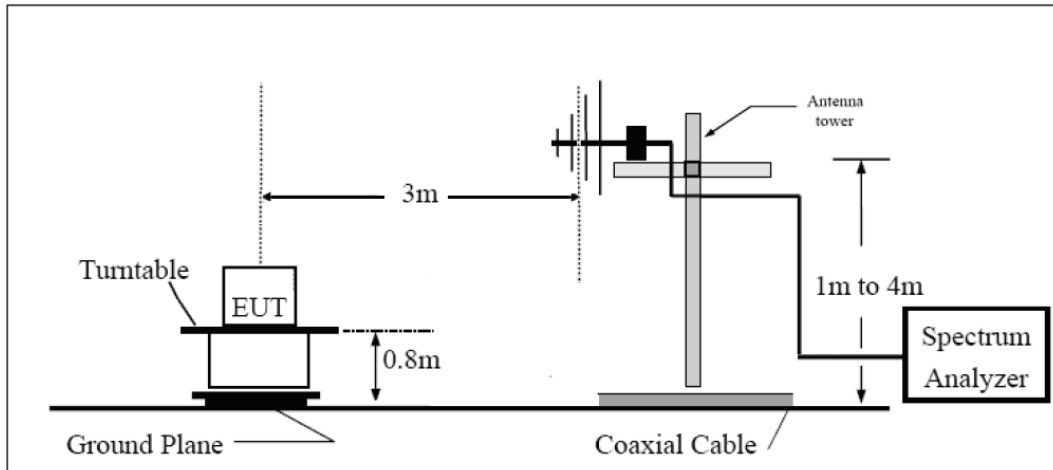

Above 1GHz

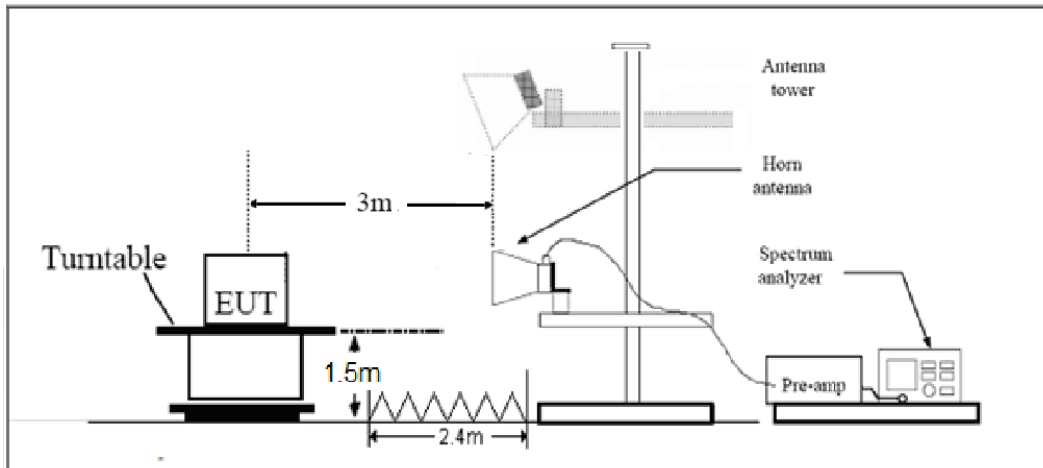



Note: Area side: 2.4mX3.6m

Limits

Rule Part 24.238(a) specifies that “on any frequency outside a licensee's frequency block, the power of any emission shall be attenuated below the transmitter power (P) by at least $43 + 10 \log_{10}(P)$ dB.”

Limit	-13 dBm
-------	---------

Measurement Uncertainty

The assessed measurement uncertainty to ensure 95% confidence level for the normal distribution is with the coverage factor $k = 1.96$, $U = 3.55$ dB.

Test Result

Sweep the whole frequency band through the range from 9kHz to the 10th harmonic of the carrier, the emissions below the noise floor will not be recorded in the report.

GSM 1900 CH-Middle

Harmonic	Frequency (MHz)	SG (dBm)	Cable Loss (dB)	Gain (dBi)	Antenna Polarization	EIRP Level (dBm)	Limit (dBm)	Margin (dB)	Azimuth (deg)
2	3760.0	-59.31	5.10	11.05	Horizontal	-53.36	-13.00	40.36	135
3	5640.0	-49.40	5.42	12.65	Horizontal	-42.17	-13.00	29.17	180
4	7520.0	-55.36	6.70	13.85	Horizontal	-48.21	-13.00	35.21	315
5	9400.0	-52.05	7.01	14.75	Horizontal	-44.31	-13.00	31.31	0
6	11280.0	-52.46	7.48	15.95	Horizontal	-43.99	-13.00	30.99	90
7	13160.0	-54.21	7.51	16.55	Horizontal	-45.17	-13.00	32.17	270
8	15040.0	-51.94	8.24	15.35	Horizontal	-44.83	-13.00	31.83	180
9	16920.0	-46.84	8.41	14.95	Horizontal	-40.30	-13.00	27.30	45
10	18800.0	--	--	--	--	--	--	--	--

Note: 1.The other Spurious RF Radiated emissions level is no more than noise floor.
 2. The worst emission was found in the antenna is Horizontal position.

LTE Band 2 1.4MHz CH-Middle

Harmonic	Frequency (MHz)	SG (dBm)	Cable Loss (dB)	Gain (dBi)	Antenna Polarization	EIRP Level (dBm)	Limit (dBm)	Margin (dB)	Azimuth (deg)
2	3759.0	-58.18	5.10	11.05	Horizontal	-52.23	-13.00	39.23	270
3	5638.9	-49.34	5.42	12.65	Horizontal	-42.11	-13.00	29.11	135
4	7520.0	-55.89	6.70	13.85	Horizontal	-48.74	-13.00	35.74	45
5	9400.0	-54.44	7.01	14.75	Horizontal	-46.70	-13.00	33.70	225
6	11280.0	-53.90	7.48	15.95	Horizontal	-45.43	-13.00	32.43	0
7	13160.0	-52.29	7.51	16.55	Horizontal	-43.25	-13.00	30.25	90
8	15040.0	-49.68	8.24	15.35	Horizontal	-42.57	-13.00	29.57	135
9	16920.0	-47.53	8.41	14.95	Horizontal	-40.99	-13.00	27.99	45
10	18800.0	--	--	--	--	--	--	--	--

Note: 1.The other Spurious RF Radiated emissions level is no more than noise floor.
 2. The worst emission was found in the antenna is Horizontal position.

LTE Band 2 5MHz CH-Middle

Harmonic	Frequency (MHz)	SG (dBm)	Cable Loss (dB)	Gain (dBi)	Antenna Polarization	EIRP Level (dBm)	Limit (dBm)	Margin (dB)	Azimuth (deg)
2	3755.6	-58.91	5.10	11.05	Horizontal	-52.96	-13.00	39.96	225
3	5633.6	-48.32	5.42	12.65	Horizontal	-41.09	-13.00	28.09	45
4	7520.0	-55.34	6.70	13.85	Horizontal	-48.19	-13.00	35.19	90
5	9400.0	-50.73	7.01	14.75	Horizontal	-42.99	-13.00	29.99	135
6	11280.0	-53.08	7.48	15.95	Horizontal	-44.61	-13.00	31.61	225
7	13160.0	-52.24	7.51	16.55	Horizontal	-43.20	-13.00	30.20	45
8	15040.0	-50.95	8.24	15.35	Horizontal	-43.84	-13.00	30.84	315
9	16920.0	-48.44	8.41	14.95	Horizontal	-41.90	-13.00	28.90	315
10	18800.0	--	--	--	--	--	--	--	--

Note: 1.The other Spurious RF Radiated emissions level is no more than noise floor.
2. The worst emission was found in the antenna is Horizontal position.

LTE Band 2 20MHz CH-Middle

Harmonic	Frequency (MHz)	SG (dBm)	Cable Loss (dB)	Gain (dBi)	Antenna Polarization	EIRP Level (dBm)	Limit (dBm)	Margin (dB)	Azimuth (deg)
2	3742.1	-58.18	5.10	11.05	Horizontal	-52.23	-13.00	39.23	45
3	5613.4	-48.55	5.42	12.65	Horizontal	-41.32	-13.00	28.32	45
4	7484.6	-56.45	6.70	13.85	Horizontal	-49.30	-13.00	36.30	0
5	9400.0	-53.68	7.01	14.75	Horizontal	-45.94	-13.00	32.94	225
6	11280.0	-53.89	7.48	15.95	Horizontal	-45.42	-13.00	32.42	135
7	13160.0	-52.67	7.51	16.55	Horizontal	-43.63	-13.00	30.63	270
8	15040.0	-51.06	8.24	15.35	Horizontal	-43.95	-13.00	30.95	0
9	16920.0	-48.03	8.41	14.95	Horizontal	-41.49	-13.00	28.49	45
10	18800.0	--	--	--	--	--	--	--	--

Note: 1.The other Spurious RF Radiated emissions level is no more than noise floor.
2. The worst emission was found in the antenna is Horizontal position.

6. Main Test Instruments

Name	Manufacturer	Type	Serial Number	Calibration Date	Expiration Date
Base Station Simulator	R&S	CMU200	118133	2019-05-19	2020-05-18
Base Station Simulator	R&S	CMW500	113824	2019-05-19	2020-05-18
Power Splitter	Hua Xiang	SHX-GF2-2-13	10120101	/	/
Spectrum Analyzer	Key sight	N9010A	MY50210259	2019-05-19	2020-05-18
Universal Radio Communication Tester	Key sight	E5515C	MY48367192	2019-05-19	2020-05-18
Signal Analyzer	R&S	FSV30	100815	2018-12-16	2019-12-15
Loop Antenna	SCHWARZBECK	FMZB1519	1519-047	2017-09-26	2020-09-25
Trilog Antenna	SCHWARZBECK	VUBL 9163	9163-201	2017-11-18	2020-11-17
Horn Antenna	R&S	HF907	100126	2018-07-07	2020-07-06
Horn Antenna	ETS-Lindgren	3160-09	00102643	2018-06-20	2020-06-19
Signal generator	R&S	SMB 100A	102594	2019-05-19	2020-05-18
Climatic Chamber	ESPEC	SU-242	93000506	2017-12-17	2020-12-16
Preamplifier	R&S	SCU18	102327	2019-05-19	2020-05-18
MOB COMMS DC SUPPLY	Keysight	66319D	MY43004105	2019-05-19	2020-05-18
RF Cable	Agilent	SMA 15cm	0001	2019-06-14	2019-12-13
Software	R&S	EMC32	9.26.0	/	/

*****END OF REPORT *****