



FCC TEST REPORT

FCC ID: 2AP2N-QISTAND2

On Behalf of

Shenzhen Esorun Technology Co.,LTD

Foldable Wireless Charging Stand

Model No.: Qistand 2

Prepared for : Shenzhen Esorun Technology Co.,LTD
Address : Room 226, Building A, B, C, Zone B, Yuanfen Industrial Zone, Taoyuan
Community, Dalang Street, Longhua District, Shenzhen

Prepared By : Shenzhen Alpha Product Testing Co., Ltd.
Address : Building i, No.2, Lixin Road, Fuyong Street, Bao'an District,
518103, Shenzhen, Guangdong, China

Report Number : A2108131-C01-R07
Date of Receipt : August 16, 2021
Date of Test : August 16, 2021–November 9, 2021
Date of Report : November 9, 2021
Version Number : V0

TABLE OF CONTENTS

1. Test Result Summary	5
2. General Information	6
2.1. Description of Device (EUT)	6
2.2. Accessories of Device (EUT)	7
2.3. Tested Supporting System Details	7
2.4. Block Diagram of Connection between EUT and Simulators	7
2.5. Description of Test Modes	7
2.6. Test Conditions	7
2.7. Test Facility	8
2.8. Measurement Uncertainty	8
2.9. Test Equipment List	9
3. Test Results and Measurement Data	10
3.1. Conducted Emission	10
3.2. Radiated Spurious Emission Measurement	13
3.3. Test Specification	20
4. Photos of Test Setup	22
5. Photographs of EUT	24

Revision History

Revision	Issue Date	Revisions	Revised By
V0	November 9, 2021	Initial released Issue	Yannis Wen

1. Test Result Summary

Requirement	CFR 47 Section	Result
Antenna requirement	§15.203	PASS
AC Power Line Conducted Emission	§15.207	PASS
Spurious Emission	§15.209(a)(f)	PASS
Occupied Bandwidth	§15.215 (c)	PASS

Note:

1. PASS: Test item meets the requirement.
2. Fail: Test item does not meet the requirement.
3. N/A: Test case does not apply to the test object.
4. The test result judgment is decided by the limit of test standard.

2. General Information

2.1. Description of Device (EUT)

EUT Name	:	Foldable Wireless Charging Stand
Model No.	:	Qistand 2
DIFF.	:	N/A
Trademark	:	ESORUN
Power supply	:	Input : 5V/2A, 9V/2A, 12V/2A Output : 5W, 7.5W, 10W, 15W
Operation frequency	:	112~205KHz
Modulation	:	MSK
Antenna Type	:	Coil Antenna, Maximum Gain is 0dBi (This value is supplied by applicant).
Software version	:	V1.0
Hardware version	:	V1.0
Connector cable loss	:	0.5dB (This value is supplied by applicant).
Intend use environment	:	Residential, commercial and light industrial environment

2.2. Accessories of Device (EUT)

Accessories1 : /
 Manufacturer : /
 Model : /
 Ratings : /

2.3. Tested Supporting System Details

No.	Description	Manufacturer	Model	Serial Number	Certification
1	Wireless load	--	--	--	--
2	Adapter	--	HNFCQC3024UU	--	--

2.4. Block Diagram of Connection between EUT and Simulators

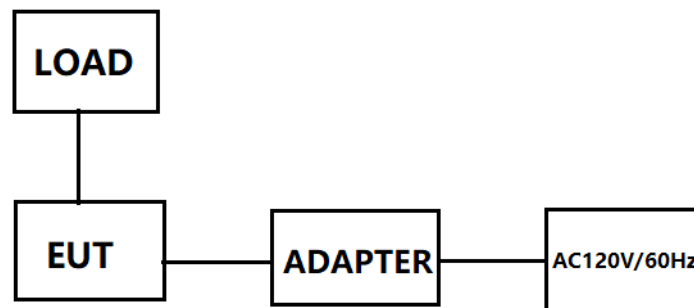

2.5. Description of Test Modes

Channel	Frequency (KHz)
1	147

2.6. Test Conditions

Items	Required	Actual
Temperature range:	15-35°C	24°C
Humidity range:	25-75%	56%
Pressure range:	86-106kPa	98kPa

2.7. Test Facility

Shenzhen Alpha Product Testing Co., Ltd

Building i, No.2, Lixin Road, Fuyong Street, Bao'an District, 518103, Shenzhen, Guangdong, China

June 21, 2018 File on Federal Communication Commission

Registration Number: 293961

July 15, 2019 Certificated by IC

Registration Number: CN0085

2.8. Measurement Uncertainty

(95% confidence levels, k=2)

Item	MU	Remark
Uncertainty for Conducted Emission Test	2.74dB	
Uncertainty for Radiation Emission test in 3m chamber (below 30MHz)	2.13 dB	Polarize: V
	2.57dB	Polarize: H
Uncertainty for Radiation Emission test in 3m chamber (30MHz to 1GHz)	3.77dB	Polarize: V
	3.80dB	Polarize: H
Uncertainty for Radiation Emission test in 3m chamber (1GHz to 25GHz)	4.13dB	Polarize: H
	4.16dB	Polarize: V
Uncertainty for radio frequency	5.4×10^{-8}	
Uncertainty for conducted RF Power	0.37dB	

2.9. Test Equipment List

Equipment	Manufacture	Model No.	Serial No.	Last cal.	Cal Interval
9*6*6 anechoic chamber	CHENYU	9*6*6	N/A	2020.09.02	3Year
Spectrum analyzer	ROHDE&SCHWARZ	FSV40-N	102137	2021.08.25	1 Year
Spectrum analyzer	Agilent	N9020A	MY499100060	2021.08.25	1 Year
Receiver	ROHDE&SCHWARZ	ESR	1316.3003K03-10208 2-Wa	2021.08.25	1 Year
Receiver	R&S	ESCI	101165	2021.08.25	1 Year
Bilog Antenna	Schwarzbeck	VULB 9168	VULB9168-438	2020.04.12	2Year
Horn Antenna	SCHWARZBECK	BBHA 9120 D	BBHA 9120 D(1201)	2020.04.12	2Year
Active Loop Antenna	SCHWARZBECK	FMZB 1519B	00059	2021.08.30	2Year
RF Cable	Resenberger	Cable 1	RE1	2021.08.25	1 Year
RF Cable	Resenberger	Cable 2	RE2	2021.08.25	1 Year
RF Cable	Resenberger	Cable 3	CE1	2021.08.25	1 Year
Pre-amplifier	HP	HP8347A	2834A00455	2021.08.25	1 Year
Pre-amplifier	Agilent	8449B	3008A02664	2021.08.25	1 Year
L.I.S.N.#1	Schwarzbeck	NSLK8126	8126-466	2021.08.25	1 Year
L.I.S.N.#2	ROHDE&SCHWARZ	ENV216	101043	2021.08.25	1 Year
Horn Antenna	SCHWARZBECK	BBHA9170	00946	2021.08.30	2 Year

Software Information			
Test Item	Software Name	Manufacturer	Version
RE	EZ-EMC	EZ	Alpha-3A1
CE	EZ-EMC	EZ	Alpha-3A1
RF-CE	MTS 8310	MW	V2.0.0.0

3. Test Results and Measurement Data

3.1. Conducted Emission

3.1.1. Test Specification

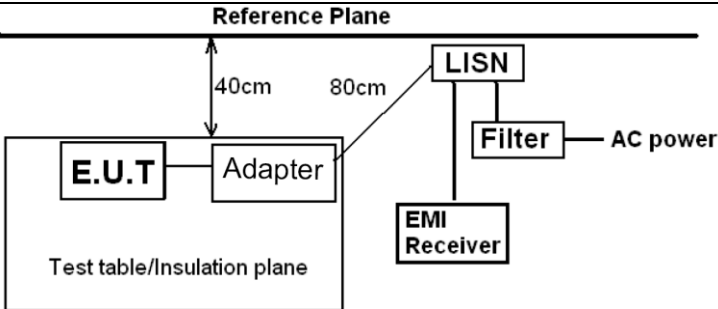
Test Requirement:	FCC Part15 C Section 15.207														
Test Method:	ANSI C63.10:2013														
Frequency Range:	150 kHz to 30 MHz														
Receiver setup:	RBW=9 kHz, VBW=30 kHz, Sweep time=auto														
Limits:	<table border="1"> <thead> <tr> <th rowspan="2">Frequency range (MHz)</th> <th colspan="2">Limit (dBuV)</th> </tr> <tr> <th>Quasi-peak</th> <th>Average</th> </tr> </thead> <tbody> <tr> <td>0.15-0.5</td> <td>66 to 56*</td> <td>56 to 46*</td> </tr> <tr> <td>0.5-5</td> <td>56</td> <td>46</td> </tr> <tr> <td>5-30</td> <td>60</td> <td>50</td> </tr> </tbody> </table>	Frequency range (MHz)	Limit (dBuV)		Quasi-peak	Average	0.15-0.5	66 to 56*	56 to 46*	0.5-5	56	46	5-30	60	50
Frequency range (MHz)	Limit (dBuV)														
	Quasi-peak	Average													
0.15-0.5	66 to 56*	56 to 46*													
0.5-5	56	46													
5-30	60	50													
Test Setup:	 <p><i>Remark</i> E.U.T: Equipment Under Test LISN: Line Impedance Stabilization Network Test table height=0.8m</p>														
Test Mode:	Charging + Transmitting Mode														
Test Procedure:	<ol style="list-style-type: none"> 1. The E.U.T is connected to an adapter through a line impedance stabilization network (L.I.S.N.). This provides a 50ohm/50uH coupling impedance for the measuring equipment. 2. The peripheral devices are also connected to the main power through a LISN that provides a 50ohm/50uH coupling impedance with 50ohm termination. (Please refer to the block diagram of the test setup and photographs). 3. Both sides of A.C. line are checked for maximum conducted interference. In order to find the maximum emission, the relative positions of equipment and all of the interface cables must be changed according to ANSI C63.10: 2013 on conducted measurement. 														
Test Result:	PASS														

3.1.2. Test Data

Please refer to following diagram for individual

Test Mode : Full Load, Empty Load
Test Result : PASS
Note: The test results are listed in next pages. All test modes has been tested, this report only reflected the worst mode. (Full Load) If the limits for the measurement with the average detector are met when using a receiver with a peak detector, the test unit shall be deemed to meet both limits and the measurement with the average detector and quasi-peak detector need not be carried out. If the limits for the measurement with the average detector are met when using a receiver with a quasi-peak detector, the test unit shall be deemed to meet both limits and the measurement with the average detector need not be carried out.

Pol | **Line**

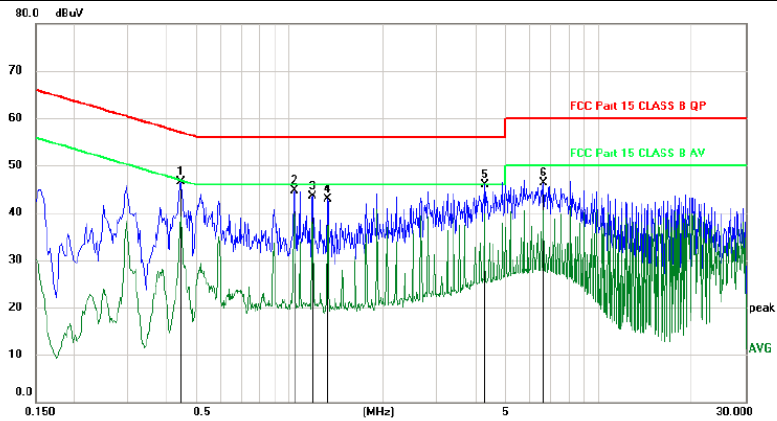

No.	Mk.	Freq.	Reading Level	Correct Factor	Measurement	Limit	Margin	Detector	Comment
		MHz	dBuV	dB	dBuV	dBuV	dB		
1		0.4440	36.63	9.95	46.58	56.99	-10.41	peak	
2		1.0350	34.70	9.92	44.62	56.00	-11.38	peak	
3		1.1849	33.59	9.89	43.48	56.00	-12.52	peak	
4		1.3290	33.09	9.90	42.99	56.00	-13.01	peak	
5	*	4.2870	35.93	9.99	45.92	56.00	-10.08	peak	
6		6.6510	36.12	10.11	46.23	60.00	-13.77	peak	

Pol | **Neutral**

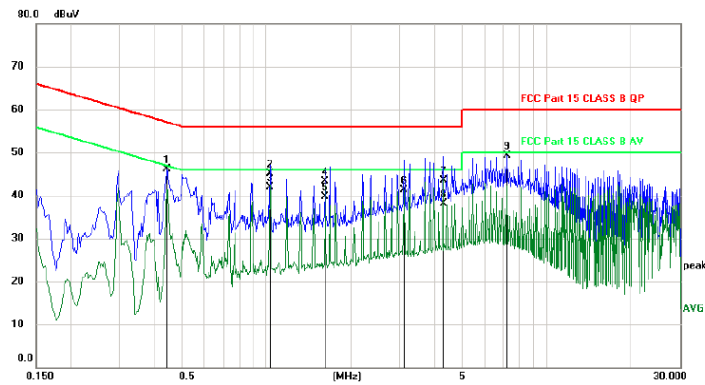

No.	Mk.	Freq.	Reading Level	Correct Factor	Measurement	Limit	Margin	Detector	Comment
		MHz	dBuV	dB	dBuV	dBuV	dB		
1		0.4410	36.12	9.95	46.07	57.04	-10.97	peak	
2		1.0320	35.28	9.92	45.20	56.00	-10.80	QP	
3	*	1.0320	31.94	9.92	41.86	46.00	-4.14	AVG	
4		1.6230	33.38	9.90	43.28	56.00	-12.72	QP	
5		1.6230	29.74	9.90	39.64	46.00	-6.36	AVG	
6		3.0960	31.29	9.96	41.25	46.00	-4.75	AVG	
7		4.2750	33.50	9.99	43.49	56.00	-12.51	QP	
8		4.2750	28.18	9.99	38.17	46.00	-7.83	AVG	
9		7.2240	39.12	10.13	49.25	60.00	-10.75	peak	

*:Maximum data x:Over limit !:over margin

Note: Measurement=Reading Level+Correc Factor. Factor=(LISN or ISN or PLC or Current Probe)Factor+Cable

3.2. Radiated Spurious Emission Measurement

3.2.1. Test Specification

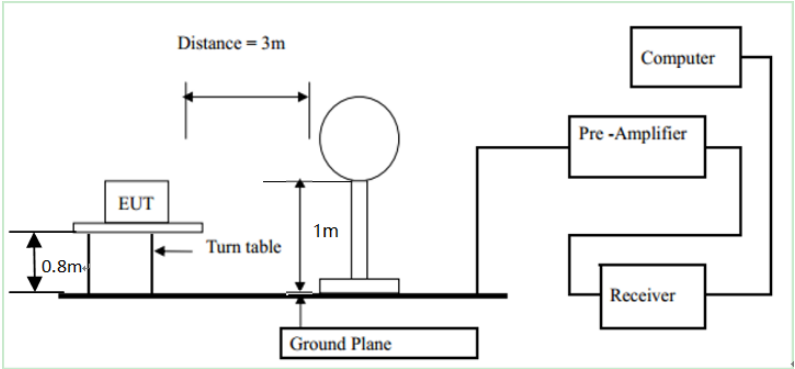
Test Requirement:	FCC Part15 C Section 15.209					
Test Method:	ANSI C63.10: 2013					
Frequency Range:	9 kHz to 25 GHz					
Measurement Distance:	3 m					
Antenna Polarization:	Horizontal & Vertical					
Operation mode:	Refer to item 4.1					
Receiver Setup:	Frequency	Detector	RBW	VBW	Remark	
	9kHz- 150kHz	Quasi-peak	200Hz	1kHz	Quasi-peak Value	
	150kHz- 30MHz	Quasi-peak	9kHz	30kHz	Quasi-peak Value	
	30MHz-1GHz	Quasi-peak	100KHz	300KHz	Quasi-peak Value	
	Above 1GHz	Peak	1MHz	3MHz	Peak Value	
		Peak	1MHz	10Hz	Average Value	
Limit:	Frequency	Field Strength (microvolts/meter)	Measurement Distance (meters)			
	0.009-0.490	2400/F(KHz)	300			
	0.490-1.705	24000/F(KHz)	30			
	1.705-30	30	30			
	30-88	100	3			
	88-216	150	3			
	216-960	200	3			
	Above 960	500	3			
	Frequency	Field Strength (microvolts/meter)	Measurement Distance (meters)	Detector		
	Above 1GHz	500	3	Average		
	5000	3	Peak			
Test setup:	For radiated emissions below 30MHz					
						
	30MHz to 1GHz					

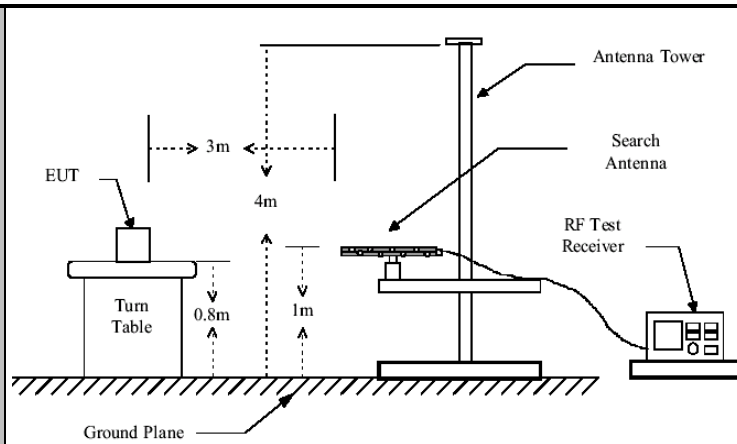

Above 1GHz

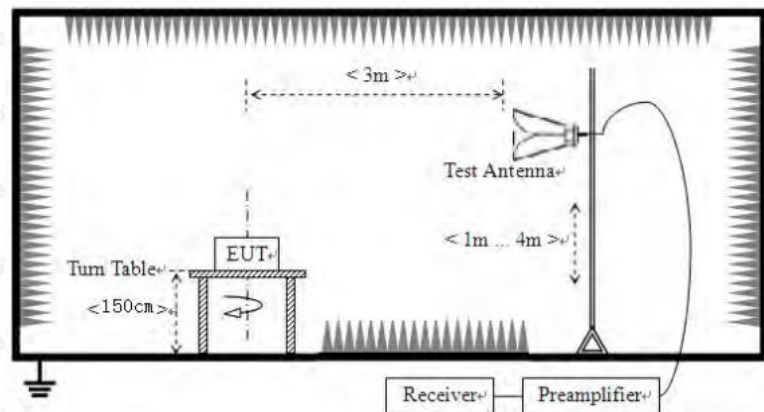

Test Procedure:

1. For the radiated emission test below 1GHz:

The EUT was placed on a turntable with 0.8 meter above ground. The EUT was set 3 meters from the interference receiving antenna, which was mounted on the top of a variable height antenna tower. The EUT was arranged to its worst case and then tune the antenna tower (from 1 m to 4 m) and turntable (from 0 degree to 360 degrees) to find the maximum reading. A pre-amp and a high PASS filter are used for the test in order to get better signal level.

For the radiated emission test above 1GHz:

Place the measurement antenna on a turntable with 1.5 meter above ground, which is away from each area of the EUT determined to be a source of emissions at the specified measurement distance, while keeping the measurement antenna aimed at the source of emissions at each frequency of significant emissions, with polarization oriented for maximum response. The measurement antenna may have to be higher or lower than the EUT, depending on the radiation pattern of the emission and staying aimed at the emission source for receiving the maximum signal. The final measurement antenna elevation shall be that which maximizes the emissions. The measurement antenna elevation for maximum emissions shall be restricted to a range of heights of from 1 m to 4 m above the ground or reference ground plane.

2. Corrected Reading: Antenna Factor + Cable Loss + Read Level - Preamp Factor = Level

3. For measurement below 1GHz, If the emission level of the EUT measured by the peak detector is 3 dB lower than the applicable

	<p>limit, the peak emission level will be reported. Otherwise, the emission measurement will be repeated using the quasi-peak detector and reported.</p> <p>4. Use the following spectrum analyzer settings:</p> <p>(1) Span shall wide enough to fully capture the emission being measured;</p> <p>(2) Set RBW=100 kHz for $f < 1$ GHz; VBW \geqRBW; Sweep = auto; Detector function = peak; Trace = max hold;</p> <p>(3) Set RBW = 1 MHz, VBW= 3MHz for $f \leq 1$ GHz for peak measurement.</p> <p>For average measurement: VBW = 10 Hz, when duty cycle is no less than 98 percent. VBW $\geq 1/T$, when duty cycle is less than 98 percent where T is the minimum transmission duration over which the transmitter is on and is transmitting at its maximum power control level for the tested mode of operation.</p>
Test mode:	Refer to section 4.1 for details
Test results:	PASS

3.2.2. Test Data

Please refer to following diagram for individual

Frequency Range	: 9KHz~30MHz
Test Mode	: TX: 147KHz
Test Results	: PASS
Note:	<ol style="list-style-type: none">1. The test results are listed in next pages.2. This mode is worst case mode, so this report only reflected the worst mode. (Full Load)3. If the limits for the measurement with the average detector are met when using a receiver with a peak detector, the test unit shall be deemed to meet both limits and the measurement with the quasi-peak detector need not be carried out.

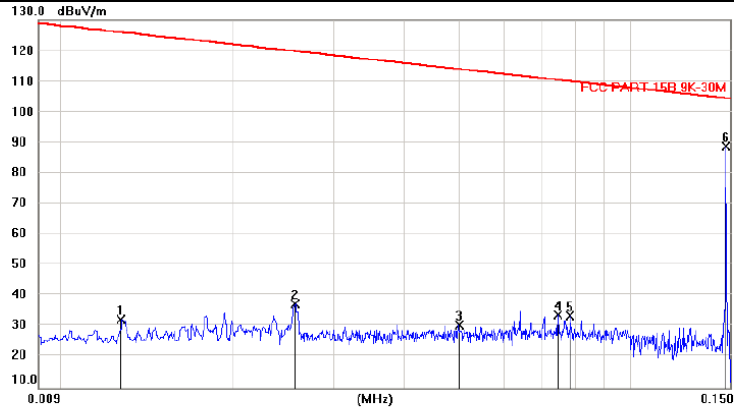

No. Mk.	Freq.	Reading Level	Correct Factor	Measurement	Limit	Margin	Antenna Height	Table Degree
	MHz	dBuV	dB	dBuV/m	dBuV/m	dB	cm	degree
1	0.0126	10.81	21.43	32.24	125.8	-93.63	peak	
2	0.0256	16.33	21.11	37.44	119.7	-82.26	peak	
3	0.0498	10.74	19.91	30.65	113.9	-83.26	peak	
4	0.0744	13.60	20.13	33.73	110.4	-76.68	peak	
5	0.0784	13.57	20.07	33.64	109.9	-76.32	peak	
6 *	0.1476	68.46	20.17	88.63	104.4	-15.82	peak	

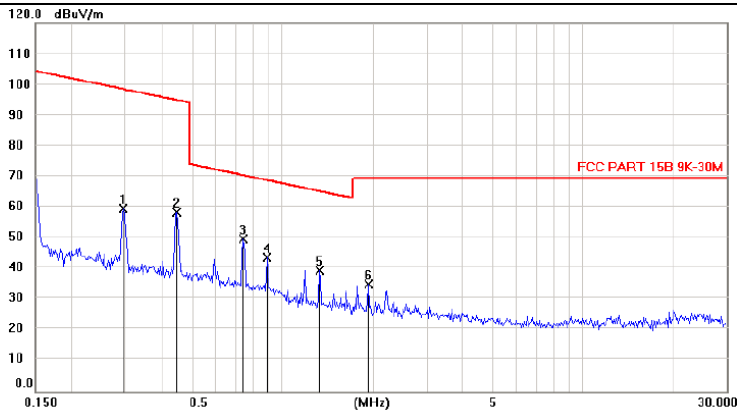

No. Mk.	Freq.	Reading Level	Correct Factor	Measurement	Limit	Margin	Antenna Height	Table Degree
	MHz	dBuV	dB	dBuV/m	dBuV/m	dB	cm	degree
1	0.2948	91.01	-31.34	59.67	98.42	-38.75	peak	
2	0.4428	89.79	-31.38	58.41	94.88	-36.47	peak	
3 *	0.7400	81.07	-31.41	49.66	70.36	-20.70	peak	
4	0.8844	75.22	-31.43	43.79	68.79	-25.00	peak	
5	1.3278	70.87	-31.45	39.42	65.21	-25.79	peak	
6	1.9290	66.56	-31.47	35.09	69.54	-34.45	peak	

*:Maximum data x:Over limit !:over margin

Note: Measurement=Reading Level+Correc Factor. Factor=(LISN or ISN or PLC or Current Probe)Factor+Cable

Frequency Range	: 30MHz~1000MHz
Test Mode	: Full Load, Half Load, Empty Load
Test Results	: PASS
Note:	<ol style="list-style-type: none"> 1. The test results are listed in next pages. 2. All test modes has been tested, this report only reflected the worst mode. (Full Load) 3. If the limits for the measurement with the average detector are met when using a receiver with a peak detector, the test unit shall be deemed to meet both limits and the measurement with the quasi-peak detector need not be carried out.

Frequency Range	: Above 1GHz		
EUT	: /	Test Date	: /
M/N	: /	Temperature	: /
Test Engineer	: /	Humidity	: /
Test Mode	: /		
Test Results	: N/A		
Note:	<ol style="list-style-type: none"> 1. The highest frequency of the internal sources of the EUT is less than 108 MHz, the measurement shall only be made up to 1 GHz. So the frequency rang above 1GHz radiation test not applicable. 		

30MHz-1GHz

Pol	Vertical
------------	-----------------

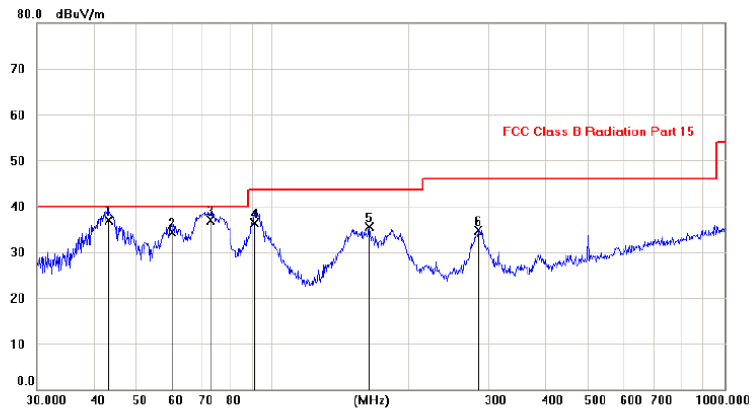

No. Mk.	Freq.	Reading Level	Correct Factor	Measurement	Limit	Margin	Antenna Height	Table Degree	Comment
	MHz	dBuV	dB	dBuV/m	dBuV/m	dB	cm	degree	
1 *	43.2420	22.73	14.22	36.95	40.00	-3.05			QP
2	60.0550	21.14	13.23	34.37	40.00	-5.63			QP
3	72.6086	25.88	10.93	36.81	40.00	-3.19			QP
4	90.8873	26.05	10.17	36.22	43.50	-7.28			QP
5	163.3344	20.76	14.72	35.48	43.50	-8.02			peak
6	285.1433	21.02	13.73	34.75	46.00	-11.25			peak

Pol	Horizontal
------------	-------------------

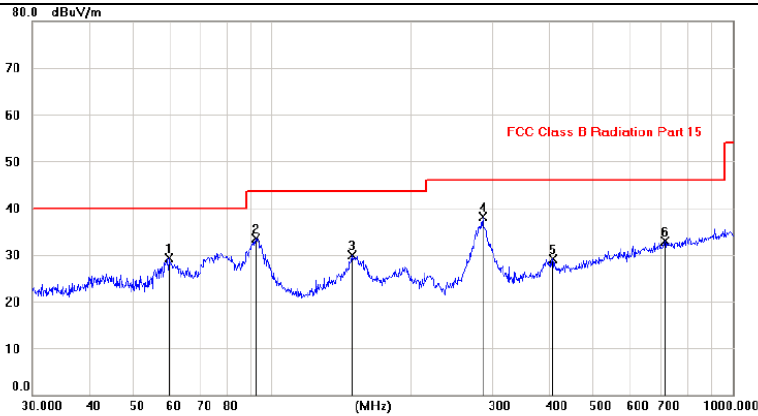

No. Mk.	Freq.	Reading Level	Correct Factor	Measurement	Limit	Margin	Antenna Height	Table Degree	Comment
	MHz	dBuV	dB	dBuV/m	dBuV/m	dB	cm	degree	
1	59.5240	16.00	13.25	29.25	40.00	-10.75			peak
2	92.1388	23.25	10.22	33.47	43.50	-10.03			peak
3	148.6494	14.98	14.96	29.94	43.50	-13.56			peak
4 *	286.8482	24.30	13.78	38.08	46.00	-7.92			peak
5	406.9433	12.68	16.41	29.09	46.00	-16.91			peak
6	713.0056	10.90	21.92	32.82	46.00	-13.18			peak

3.3. Test Specification

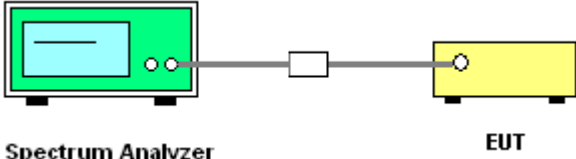
Test Requirement:	FCC Part15 C Section 15.215(c)
Test Method:	ANSI C63.10: 2013
Limit:	N/A
Test Procedure:	<ol style="list-style-type: none"> 1. According to the follow Test-setup, keep the relative position between the artificial antenna and the EUT. 2. Set to the maximum power setting and enable the EUT transmit continuously. 3. Use the following spectrum analyzer settings for 20dB Bandwidth measurement. Span = approximately 2 to 3 times the 20 dB bandwidth, centered on a hopping channel; RBW \geq 1% of the 20 dB bandwidth; VBW \geq RBW; Sweep = auto; Detector function = peak; Trace = max hold. 4. Measure and record the results in the test report.
Test setup:	 <p>The diagram illustrates the test setup. On the left is a Spectrum Analyzer, represented by a green rectangle with a blue screen and two small circles. A cable connects it to a small white square, which is then connected to a yellow rectangle representing the EUT (Equipment Under Test). The labels 'Spectrum Analyzer' and 'EUT' are placed below their respective components.</p>
Test Mode:	Refer to section 4.1 for details
Test results:	PASS

3.3.1. Test Data

Frequency(KHz)	20dB Occupy Bandwidth (kHz)	Limit (kHz)	Conclusion
147	3.577	---	PASS

Test plots as follows:

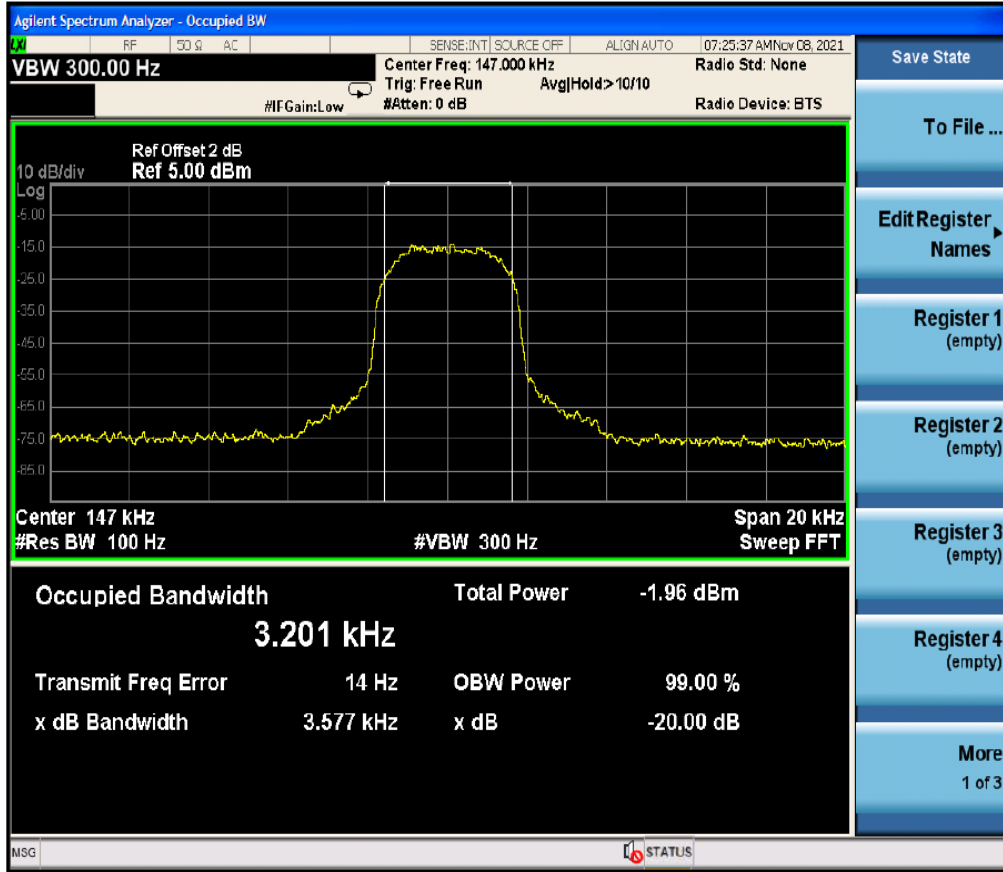

4. Photos of Test Setup

Radiated Emission

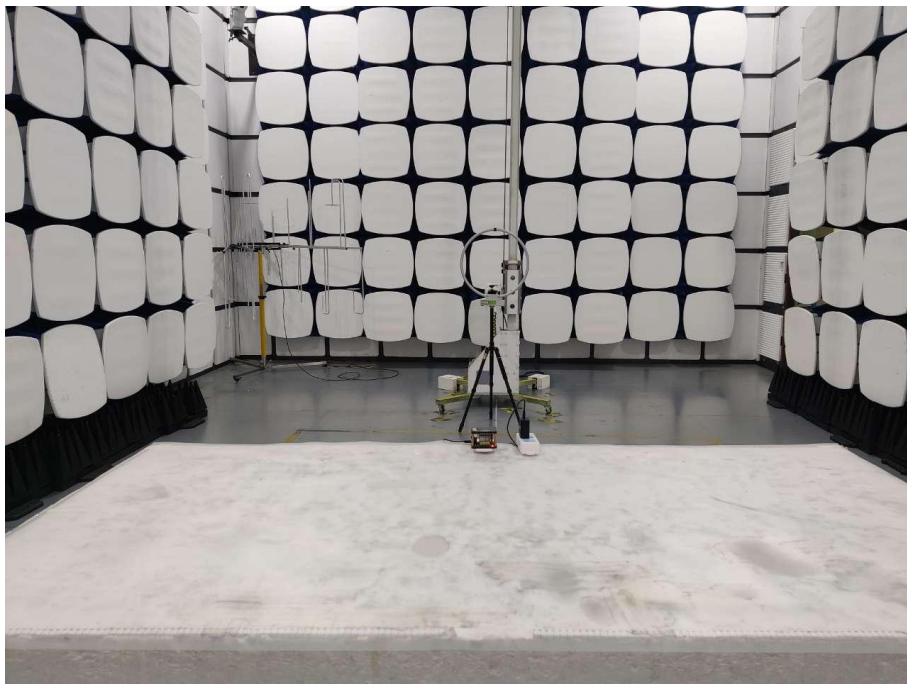
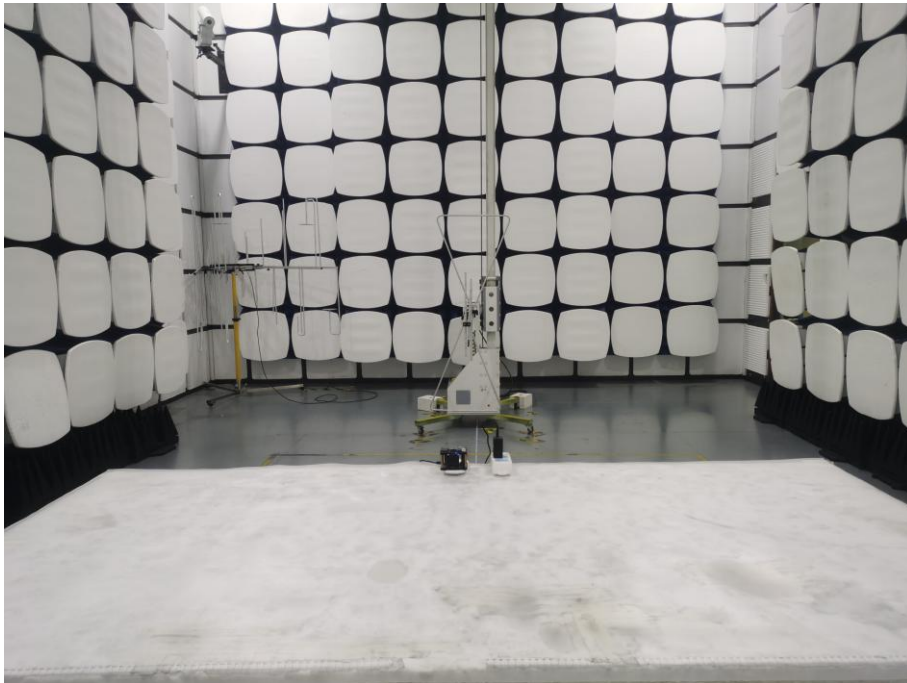

Conducted Emission



5. Photographs of EUT

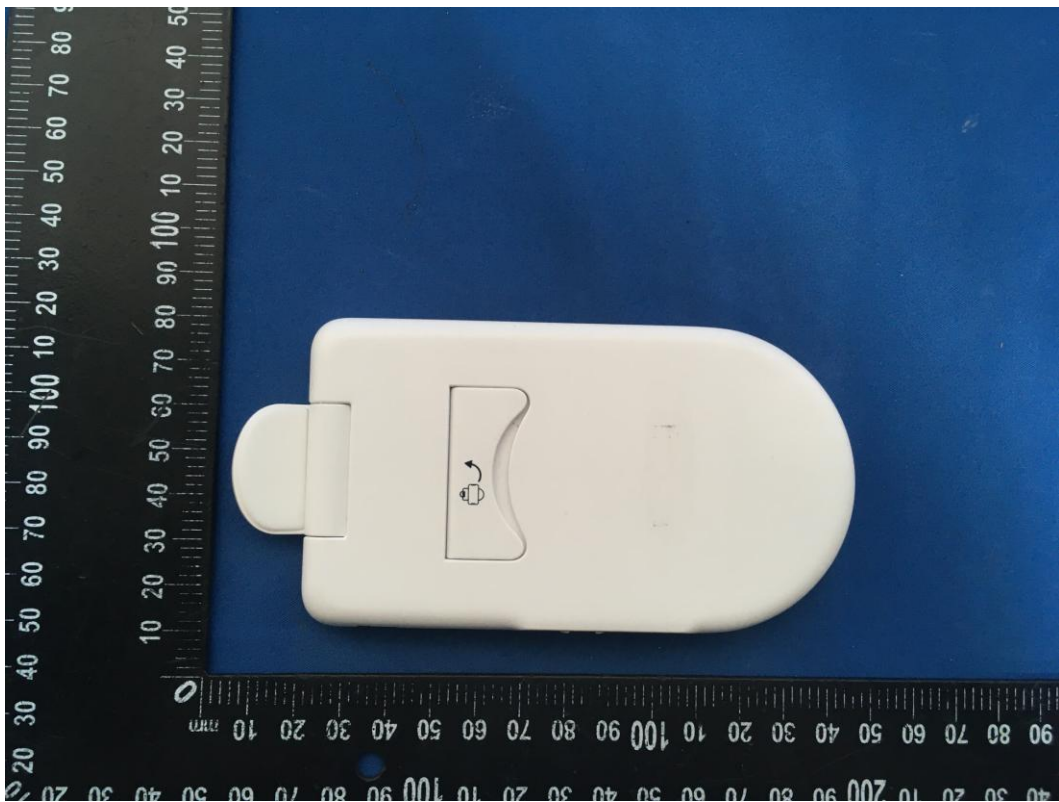

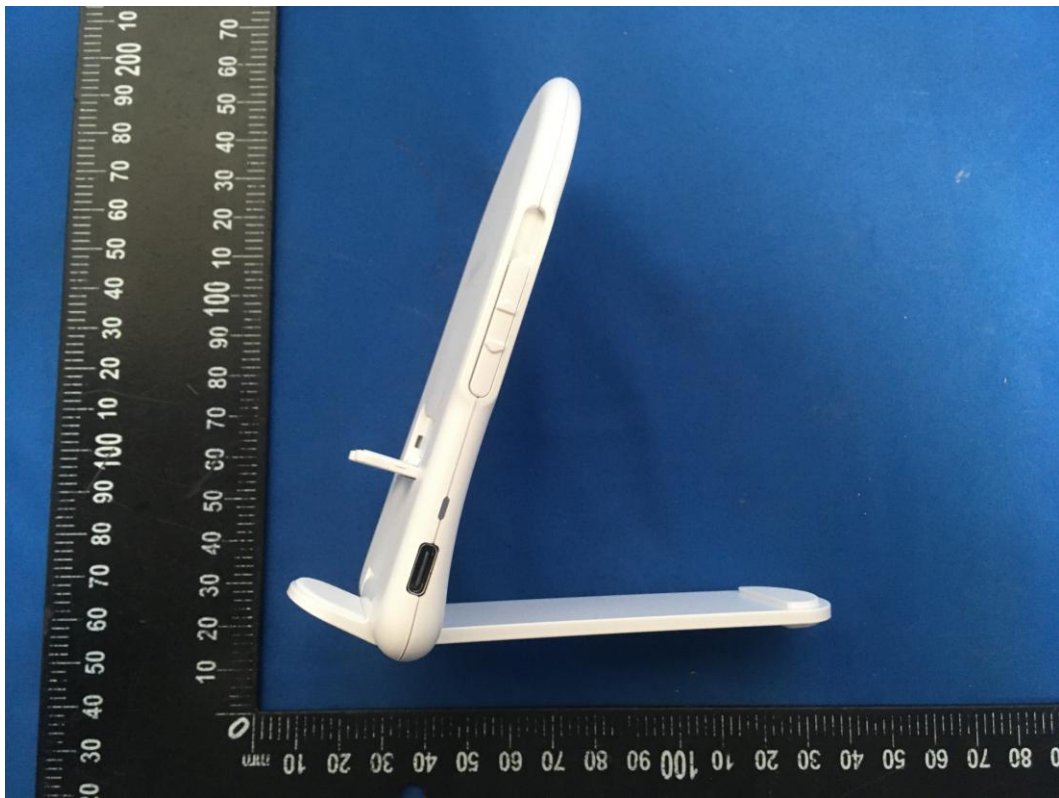



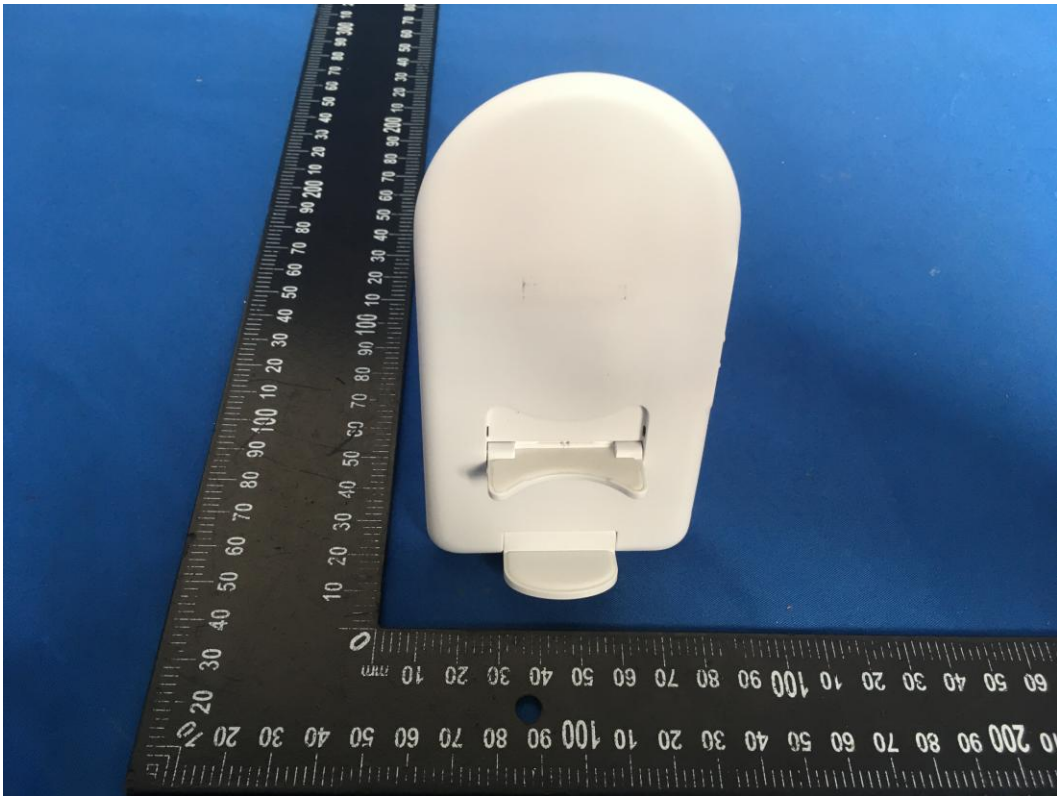



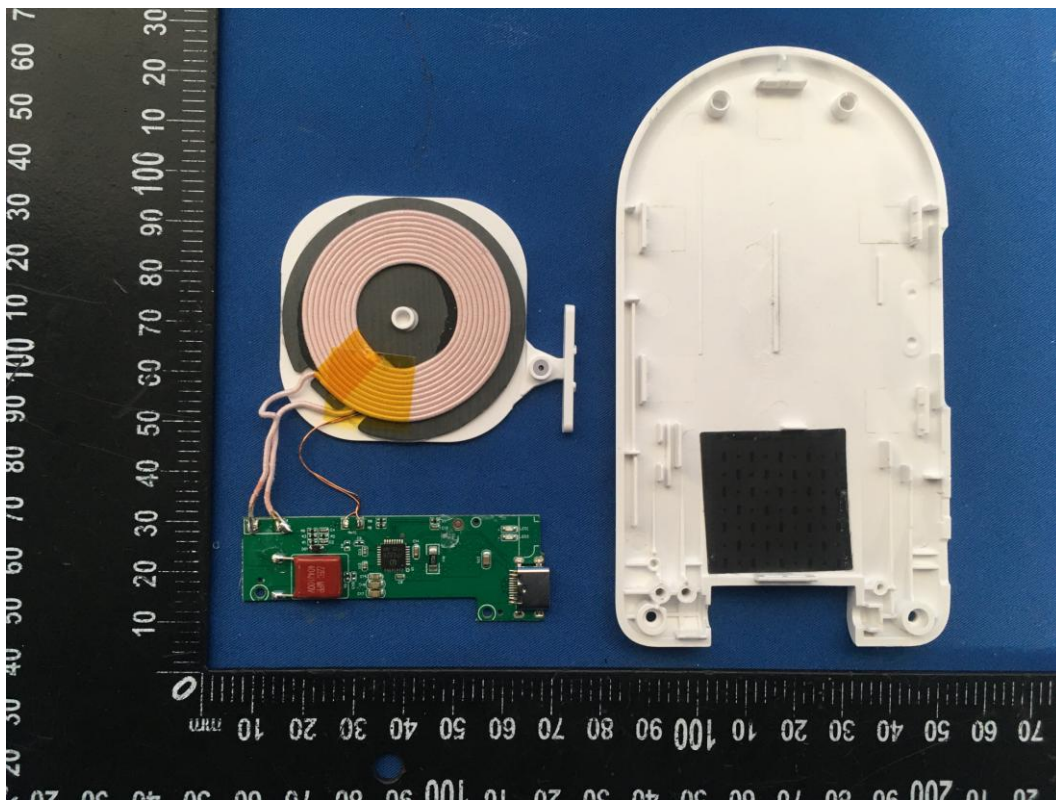
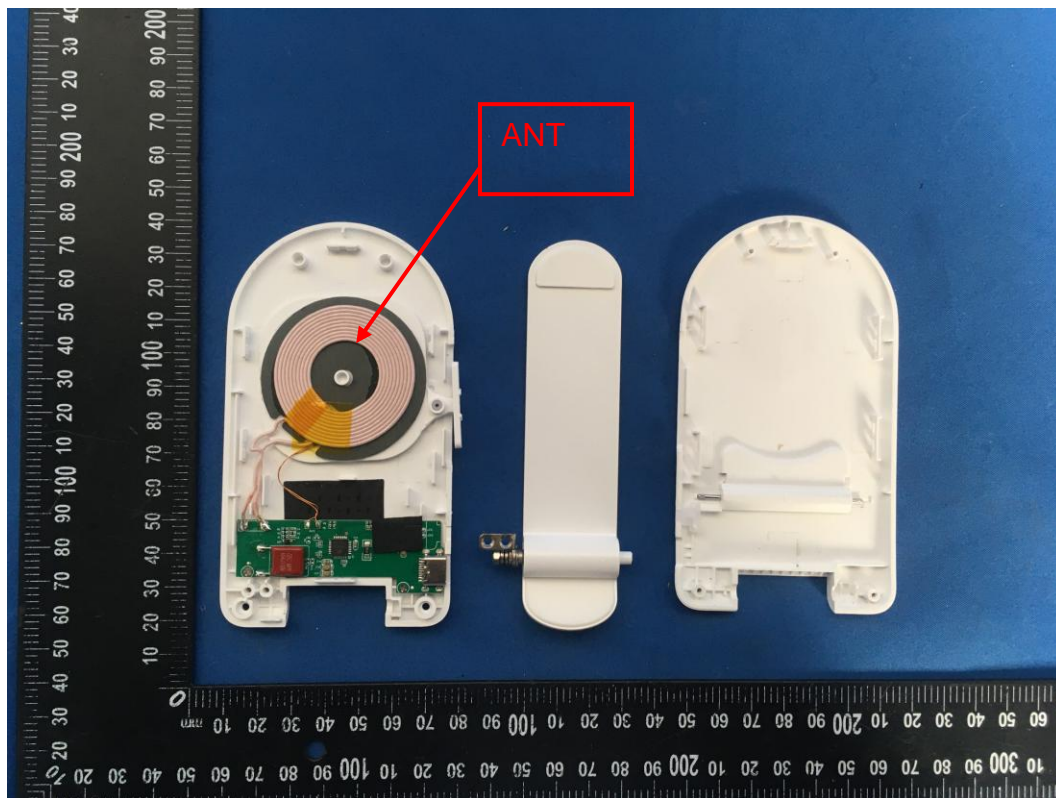

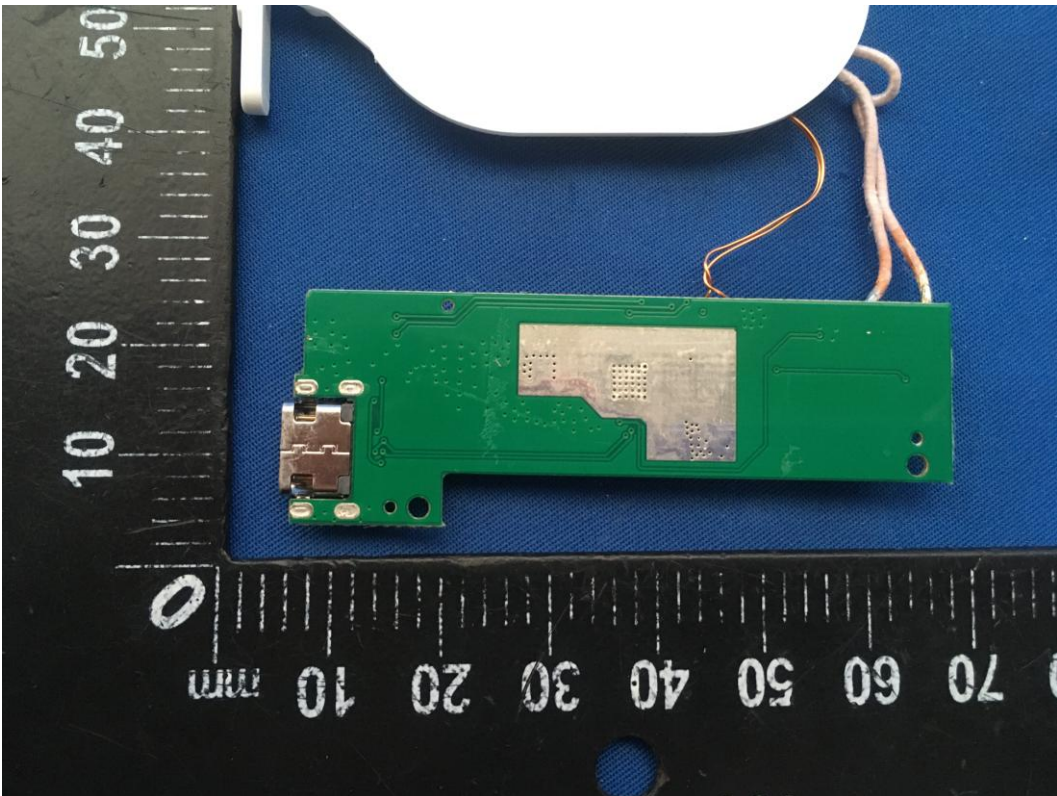
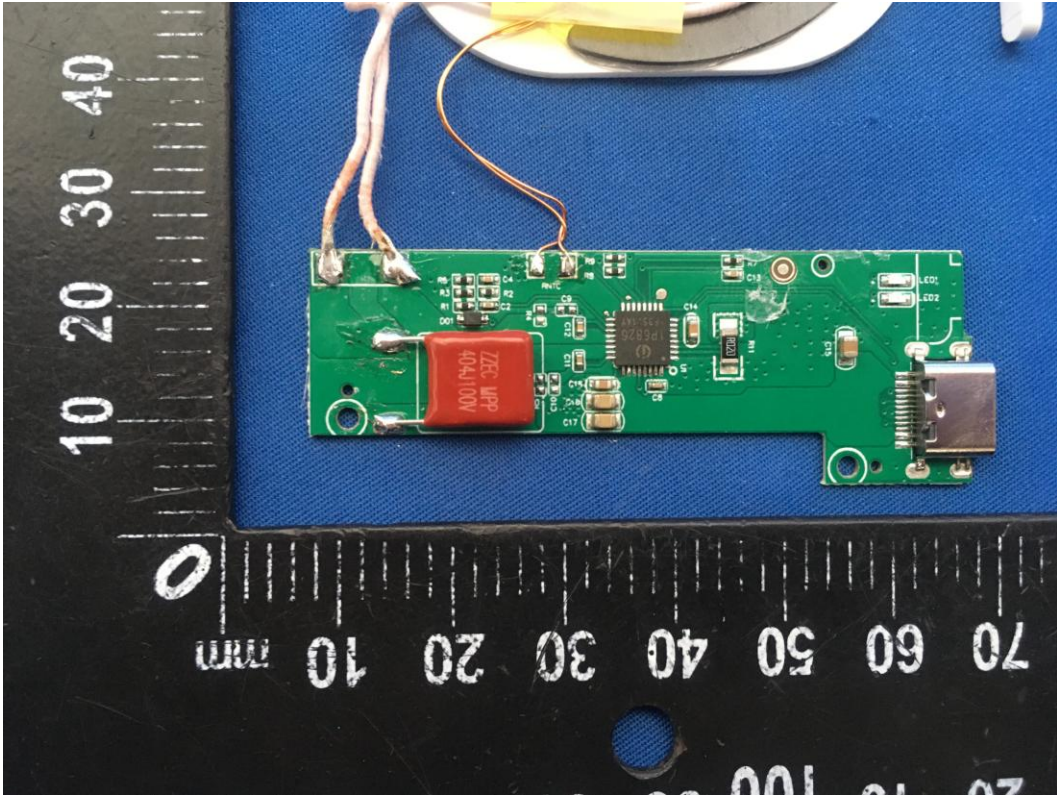

----- END OF REPORT-----